

-BREAK ALL SHARP .005-.010  
 -TOLERANCE DECIMAL  $\pm .005 \pm .0010$   
 -MATERIAL TITANIUM T2

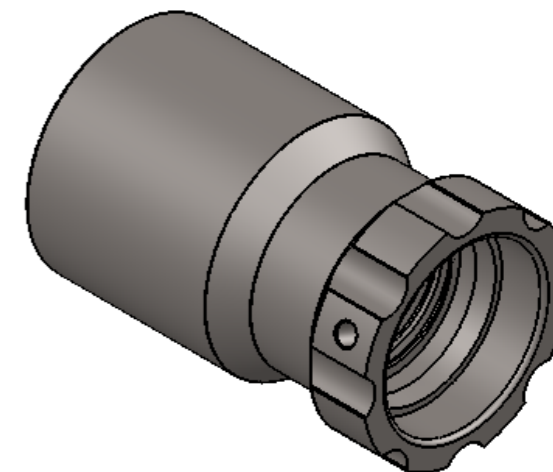

8-32 UNC THRU FIRST BRAKE

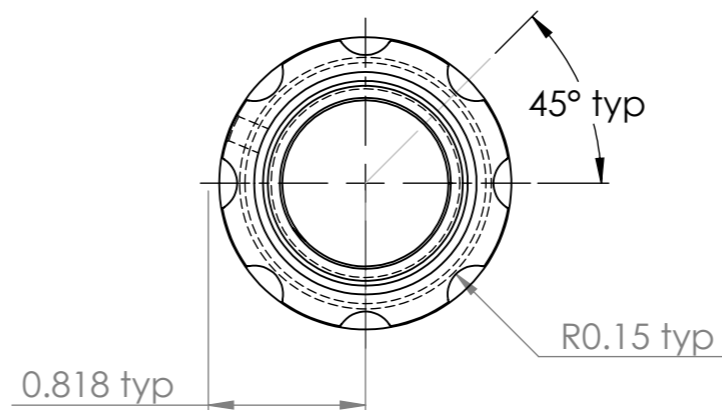
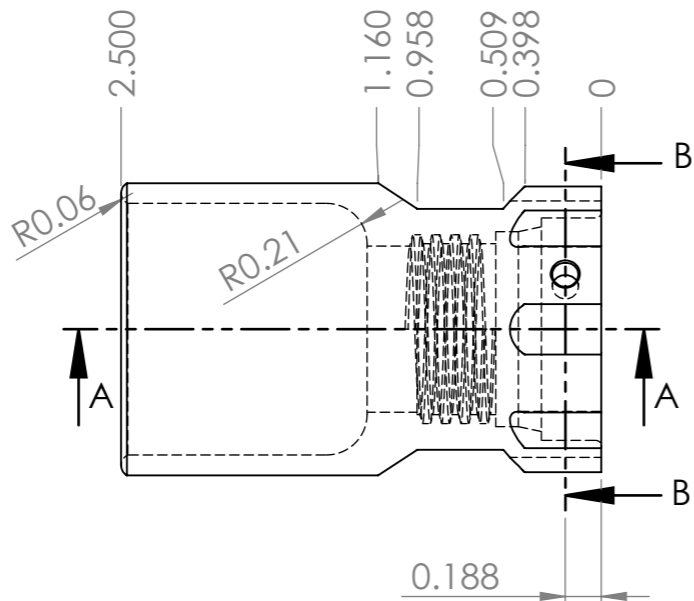
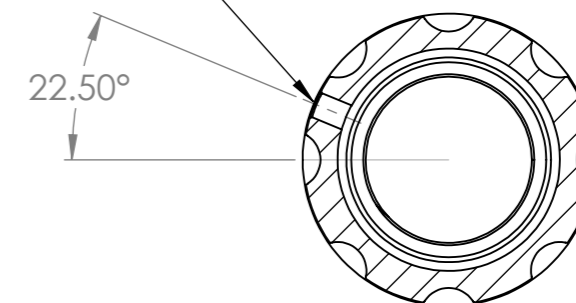

SECTION B-B

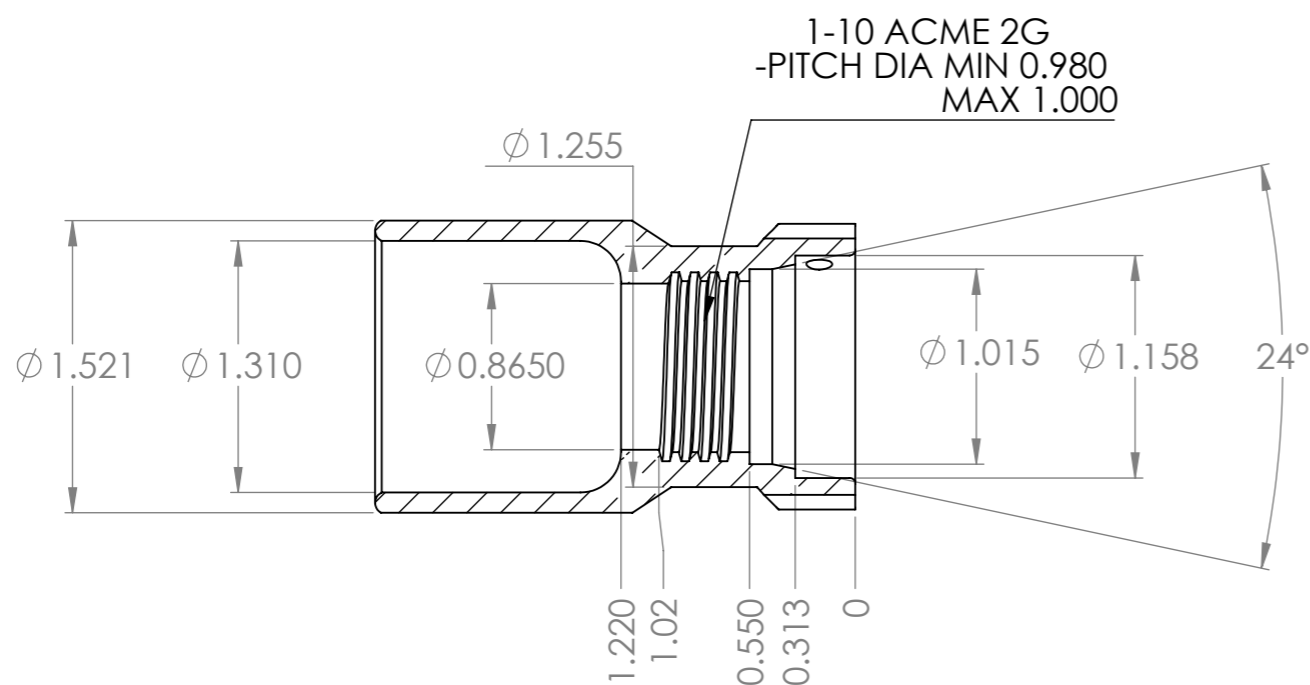

SECTION A-A

|  |  |                         |  |                                    |  |   |  |              |  |
|--|--|-------------------------|--|------------------------------------|--|---|--|--------------|--|
| UNLESS OTHERWISE SPECIFIED:<br>DIMENSIONS ARE IN MILLIMETERS |  | FINISH:<br><b>CLEAN</b> |  | DEBURR AND<br>BREAK SHARP<br>EDGES |  | DO NOT SCALE DRAWING                                    |  | REVISION     |  |
| SURFACE FINISH:  |  |                         |  |                                    |  | <b>RCMP-GRC</b>   |  |              |  |
| TOLERANCES:  |  |                         |  |                                    |  |   |  |              |  |
| LINEAR:  |  |                         |  |                                    |  | TITLE:<br><b>90T MUZZLE BRAKE<br/>BUSHING 8-32 lock</b> |  |              |  |
| ANGULAR:   |  |                         |  |                                    |  | DWG NO.   |  | A3           |  |
| DRAWN  |  | NAME                    |  | SIGNATURE                          |  | DATE  |  |              |  |
| CHK'D  |  |                         |  |                                    |  |   |  |              |  |
| APPV'D   |  |                         |  |                                    |  |   |  |              |  |
| MFG  |  |                         |  |                                    |  |   |  |              |  |
| Q.A  |  |                         |  |                                    |  | MATERIAL:   |  |              |  |
|  |  |                         |  |                                    |  | WEIGHT:   |  | SCALE:1:1    |  |
|  |  |                         |  |                                    |  |   |  | SHEET 1 OF 1 |  |