

-BRAKE ALL SHARP EDGES .010-.015
 -TOLERANCE DECIMAL +/- .005 +/- .0010
 -HARD COAT ANODIZE MIL-A-8625 TYPE III
 CLASS 2 , BLACK .002 SURFACE
 -ALL TOLERANCE APPLY AFTER ANODIZE

-M6 X1 HELICOIL
 -.400" DP MIN 2 PLCS
 - 304 SS INSERT
 - DRILL POINT MAX .530"

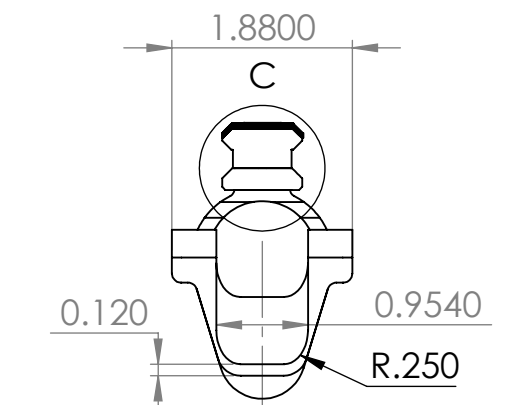

DETAIL C
SCALE 1 : 1

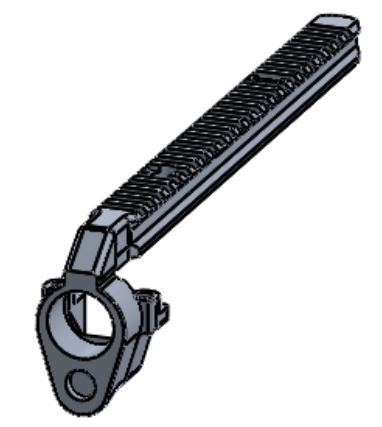
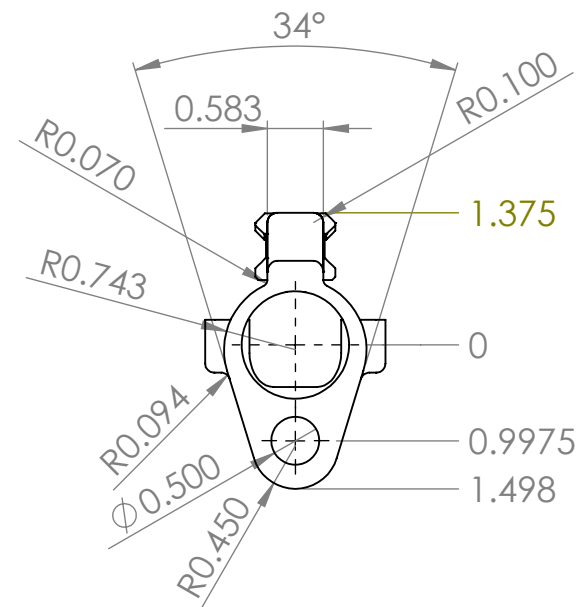
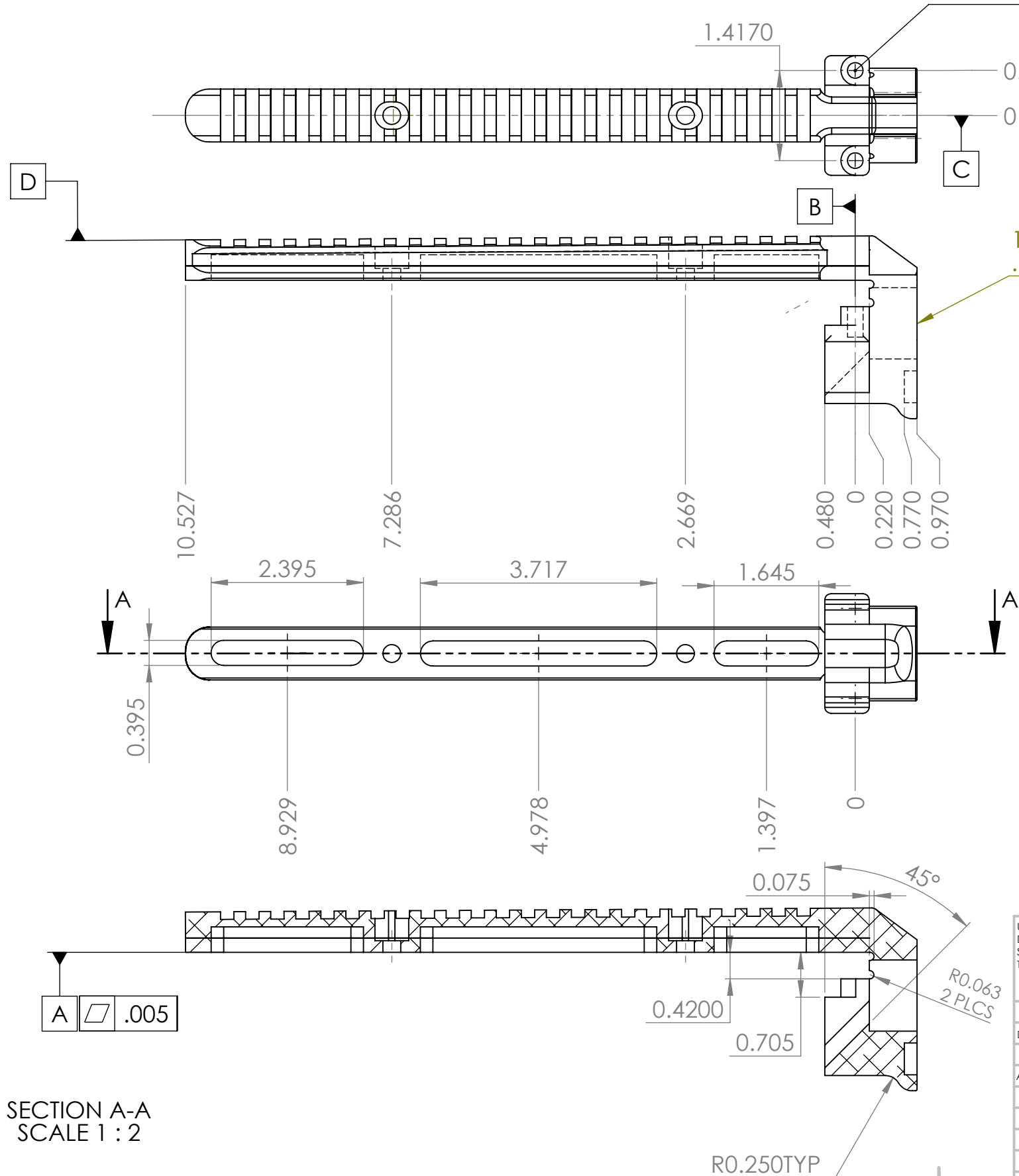
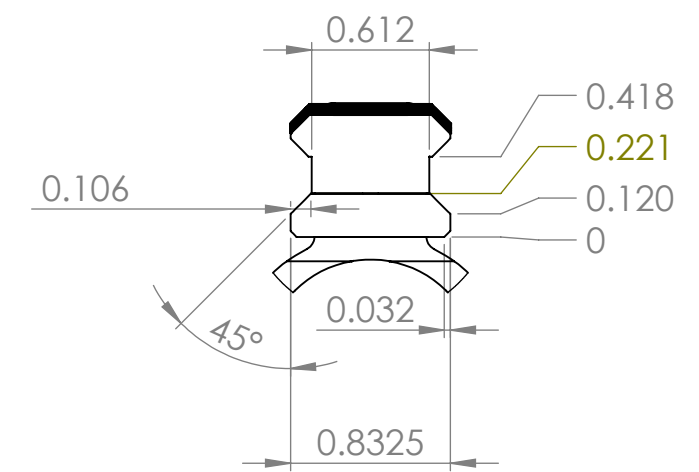

SECTION A-A
SCALE 1 : 2

UNLESS OTHERWISE SPECIFIED: DIMENSIONS ARE IN MILLIMETERS SURFACE FINISH: TOLERANCES: LINEAR: ANGULAR:			FINISH: CLEAN	DEBURR AND BREAK SHARP EDGES	DO NOT SCALE DRAWING	REVISION
			RCMP-GRC			
			TITLE: STOCK/RAIL-20MOA ADAPTER 40MM			
			MATERIAL: 7075-T6		DWG NO.	A3
			WEIGHT:		SCALE:1:5	SHEET 1 OF 2

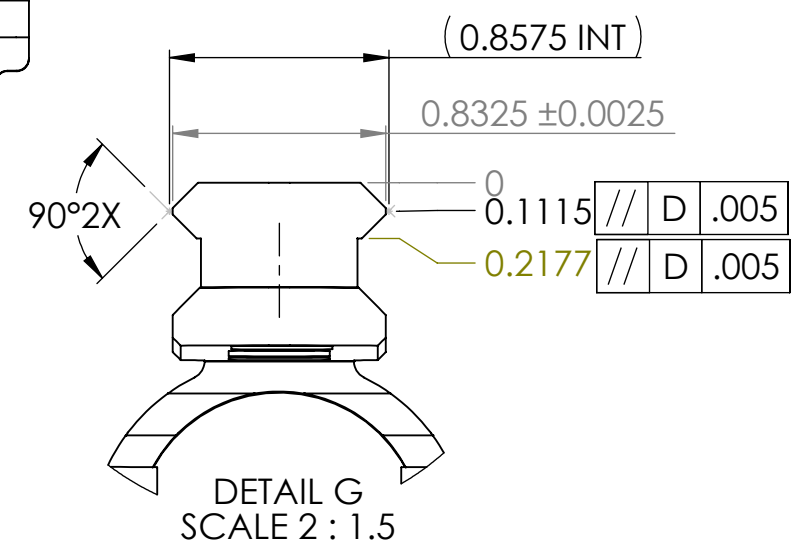
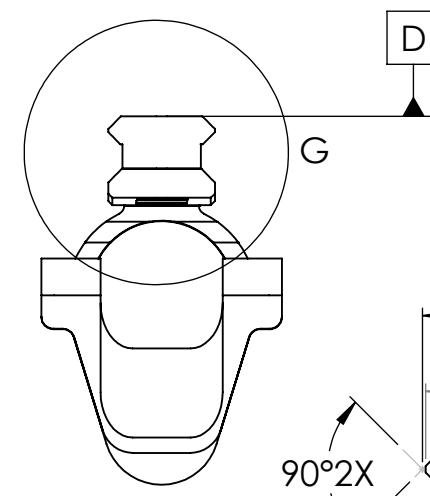
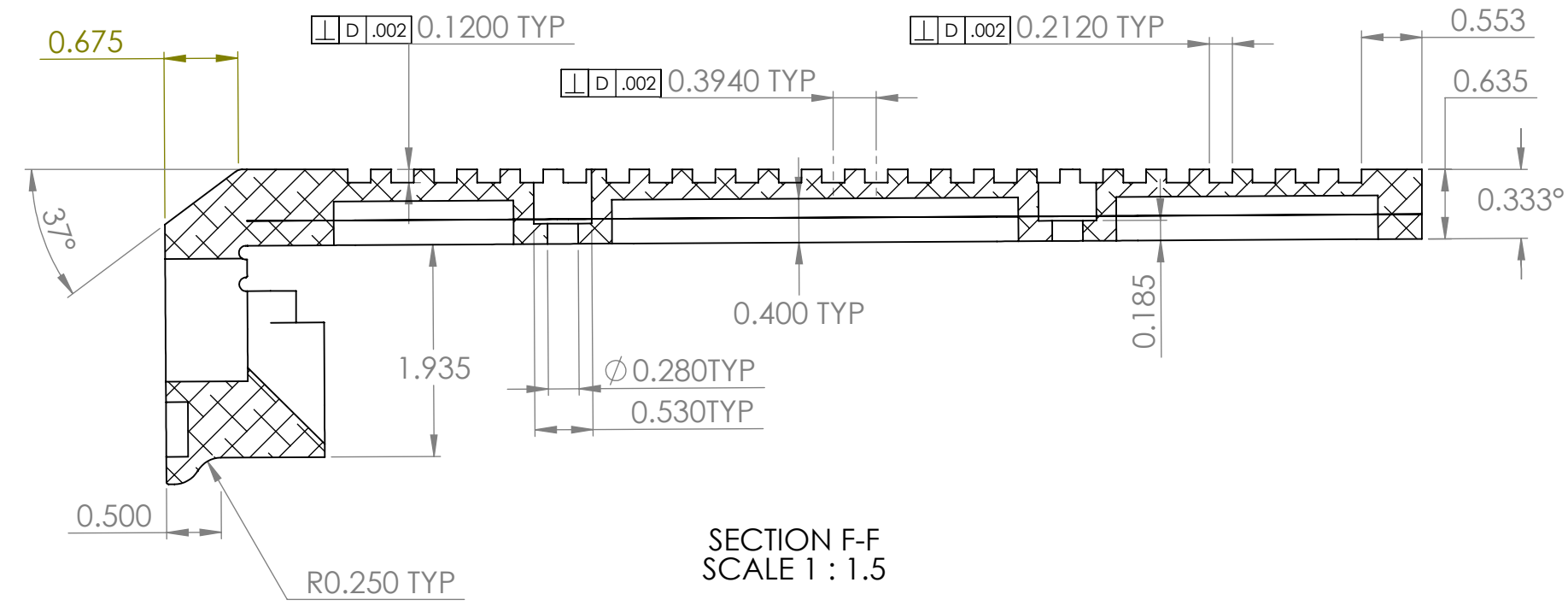
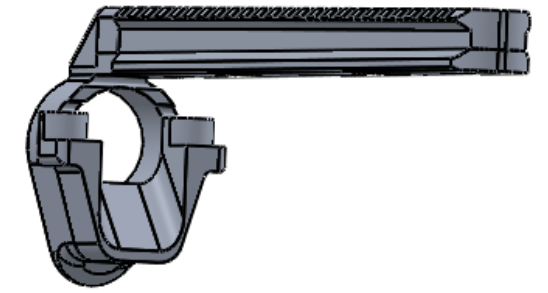
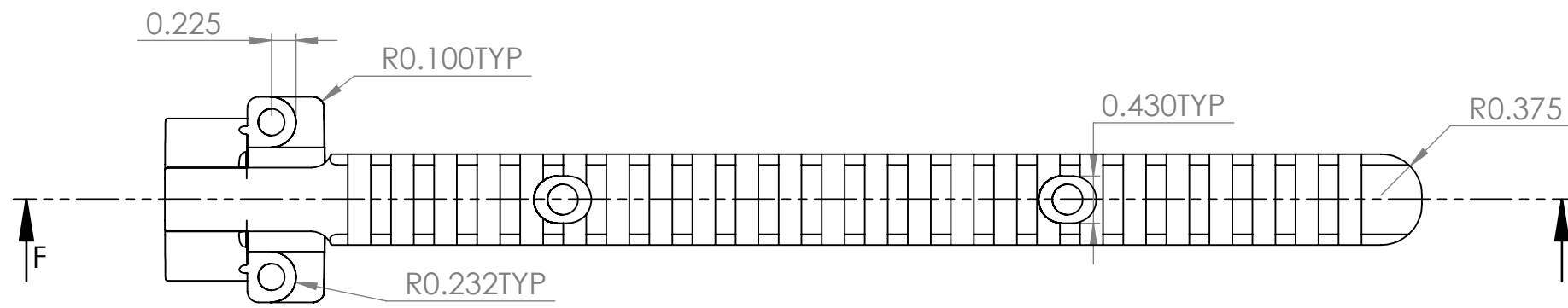

UNLESS OTHERWISE SPECIFIED: DIMENSIONS ARE IN MILLIMETERS SURFACE FINISH: TOLERANCES: LINEAR: ANGULAR:			FINISH: CLEAN		DEBURR AND BREAK SHARP EDGES		DO NOT SCALE DRAWING		REVISION		
							RCMP-GRC				
							TITLE: STOCK/RAIL - 20MOA ADAPTER 40 MM				
DRAWN			NAME		SIGNATURE		DATE		MATERIAL: 7075-T6		
CHK'D									DWG NO.		
APPV'D									SCALE:1:5		
MFG									SHEET 2 OF 2		
Q.A									A3		