

-BRAKE ALL SHARP EDGES .010-.015
 -TOLERANCE DECIMAL +/- .005 +/- .0010
 -HARD COAT ANODIZE MIL-A-8625 TYPE III
 CLASS 2, MATT BLACK .002 SURFACE
 -ALL TOLERANCE APPLY AFTER ANODIZE

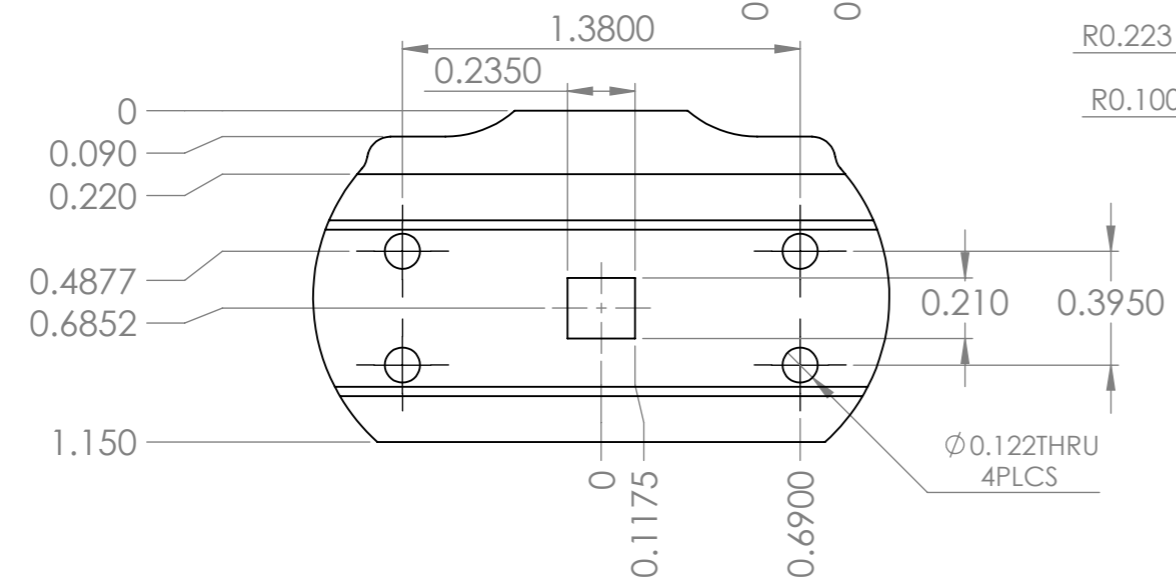
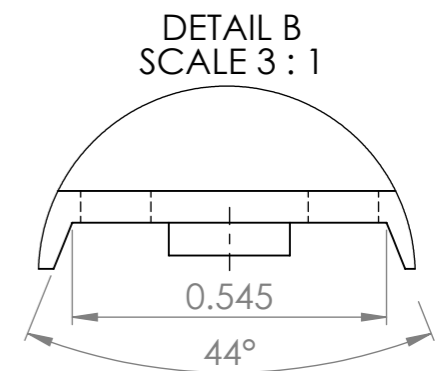
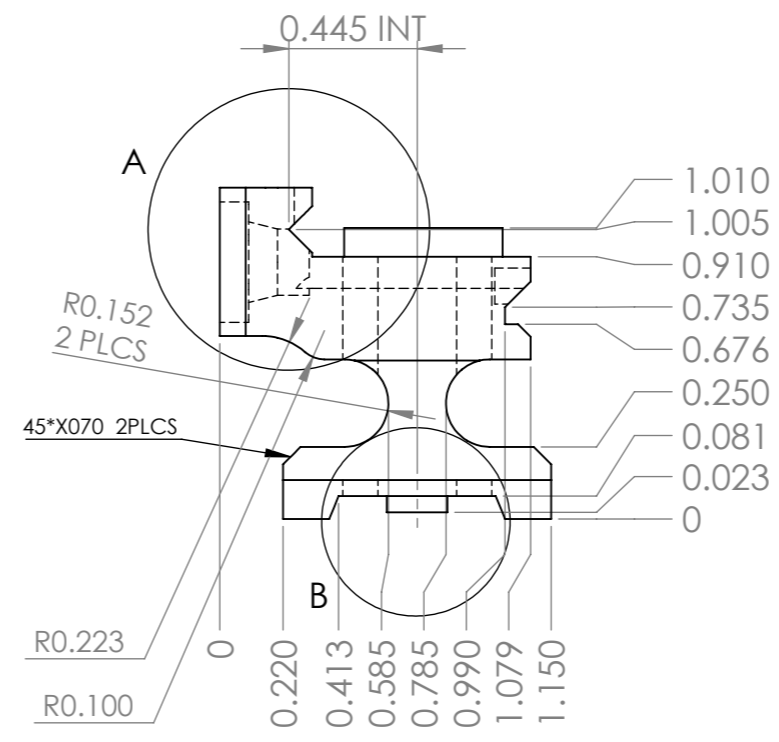
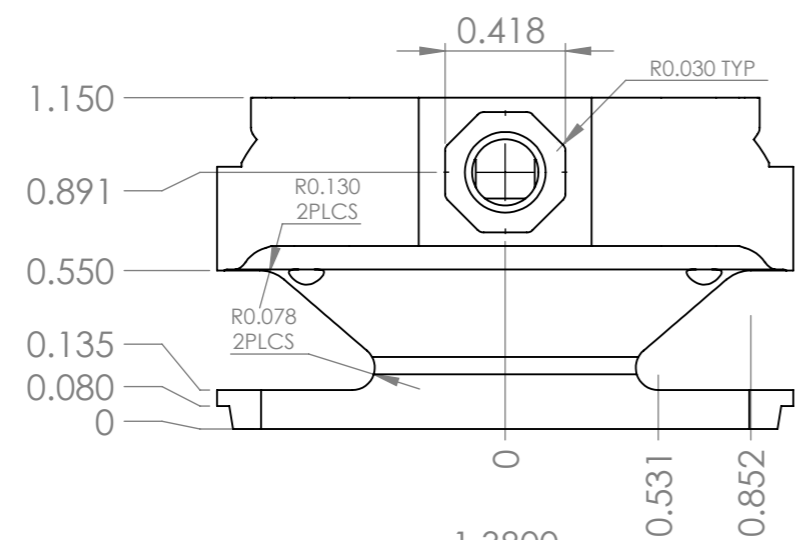
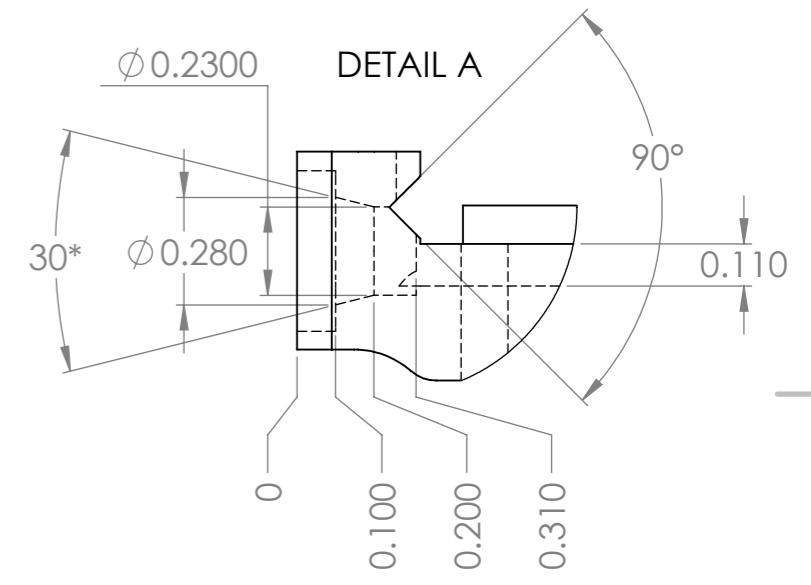
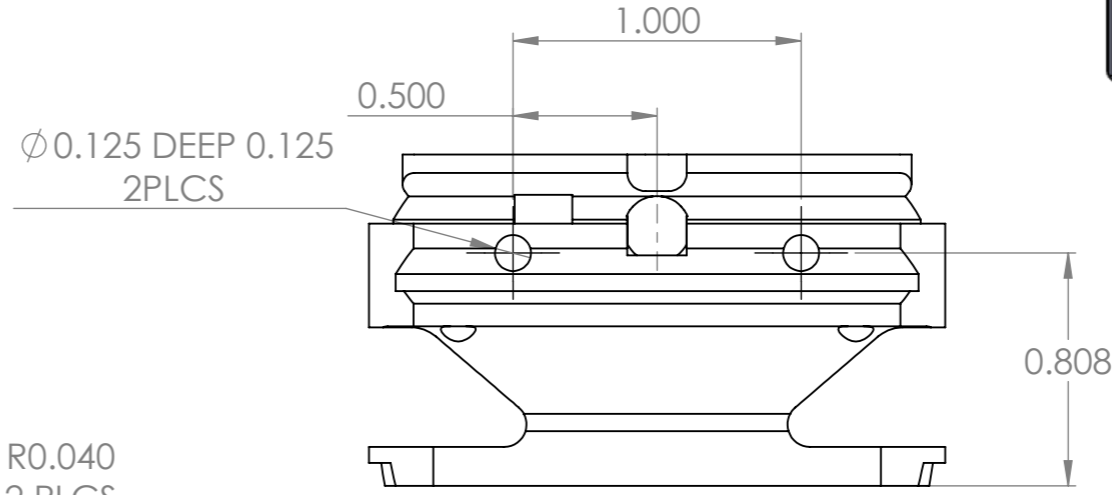
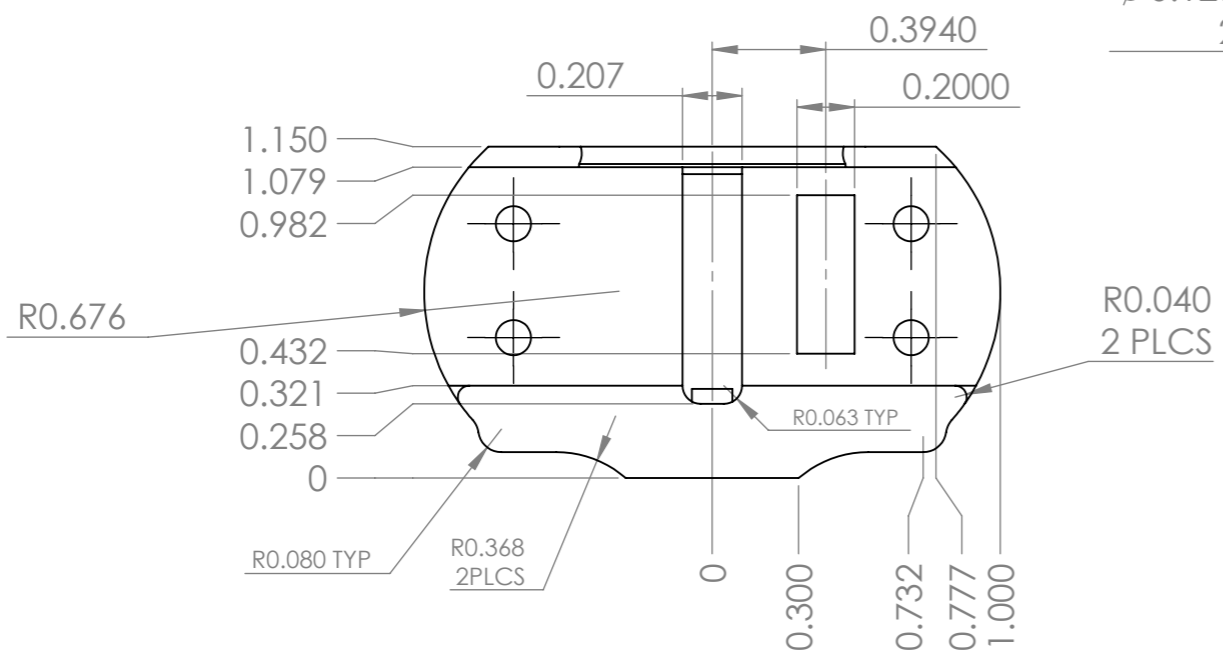
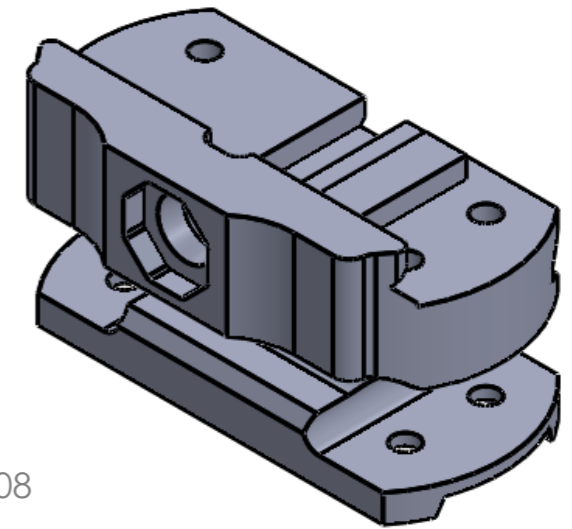

UNLESS OTHERWISE SPECIFIED: DIMENSIONS ARE IN MILLIMETERS SURFACE FINISH: TOLERANCES: LINEAR: ANGULAR:			FINISH: CLEAN		DEBURR AND BREAK SHARP EDGES		DO NOT SCALE DRAWING		REVISION		
							RCMP-GRC				
							TITLE: 300T2MOUNT-REV2				
DRAWN			SIGNATURE		DATE		DWG NO.		A3		
CHK'D							300T2MOUNT				
APPV'D							SCALE:2:1		SHEET 1 OF 1		
MFG							MATERIAL:		7075-T6		
Q.A							WEIGHT:				