

-BRAKE ALL SHARP EDGES .010-.015  
 -TOLERANCE DECIMAL +/- .005 +/- .0010  
 -HARD COAT ANODIZE MIL-A-8625 TYPE III  
 CLASS 2 , MATT BLACK .002 SURFACE  
 -ALL TOLERANCE APPLY AFTER ANODIZE

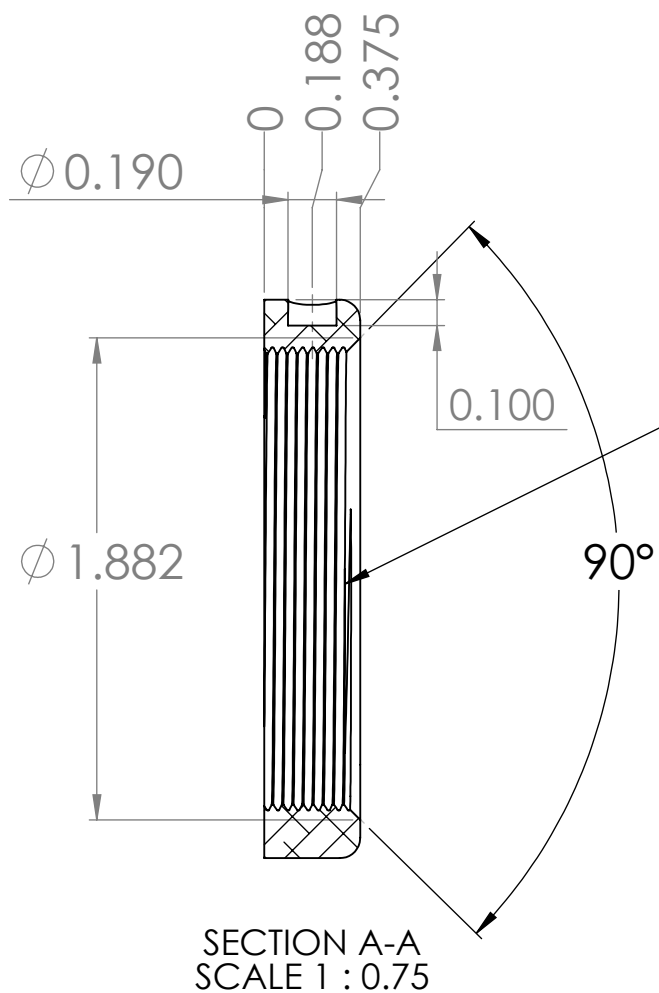
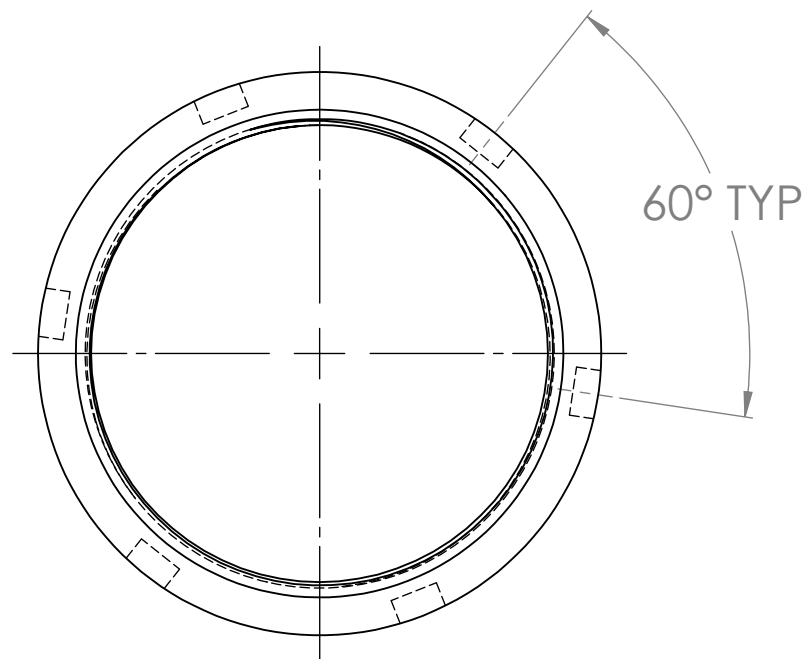
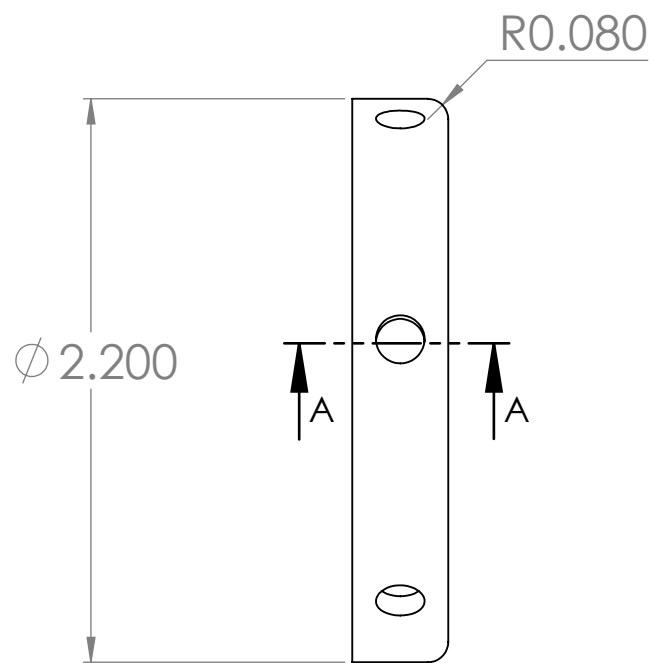

M46.5X1-6H ( THRU )  
 MAJOR DIAMETER MIN 46.526  
 MINOR DIAMETER MIN 45.443  
 MAX 45.679  
 PITCH DIAMETER MIN 45.876  
 MAX 46.051

SECTION A-A  
 SCALE 1 : 0.75

UNLESS OTHERWISE SPECIFIED: DIMENSIONS ARE IN MILLIMETERS		FINISH: <b>CLEAN</b>		DEBURR AND BREAK SHARP EDGES		DO NOT SCALE DRAWING		REVISION	
SURFACE FINISH: TOLERANCES: LINEAR: ANGULAR:						<b>RCMP-GRC</b>			
						TITLE: <b>MUZZLE PROTECTOR 40 MM LOCK</b>			
DRAWN		NAME		SIGNATURE		DATE		DWG NO. <b>MUZZLE PROTECTOR 40MM LOCK</b>	
CHK'D								A3	
APPV'D									
MFG									
Q.A						MATERIAL: <b>7075-T6</b>		SCALE:2:1	
						WEIGHT:		SHEET 1 OF 1	