

-BRAKE ALL SHARP EDGES .010-.015
 -TOLERANCE DECIMAL $\pm .005$ $\pm .0010$
 -HARD COAT ANODIZE MIL-A-8625 TYPE III
 CLASS 2 , MATT BLACK .002 SURFACE
 -ALL TOLERANCE APPLY AFTER ANODIZE

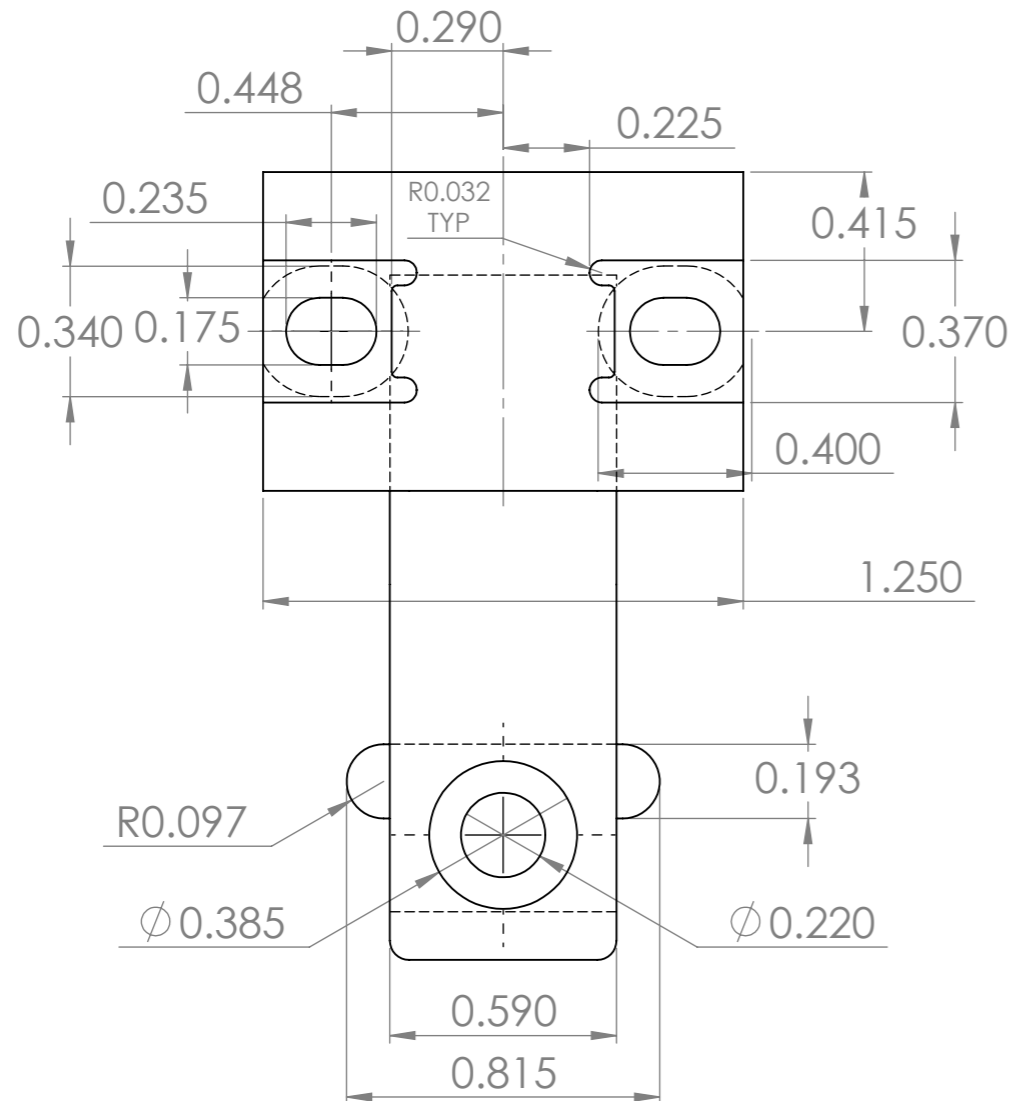
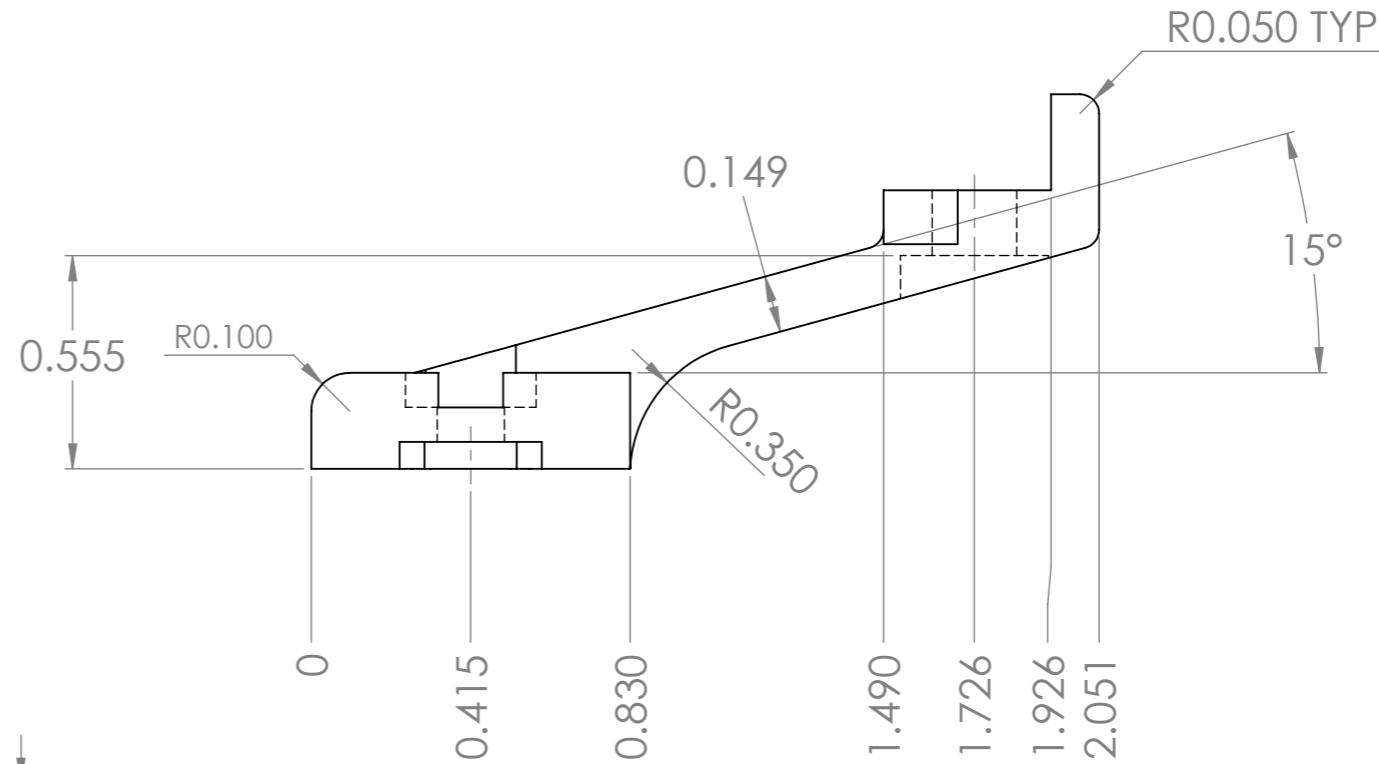
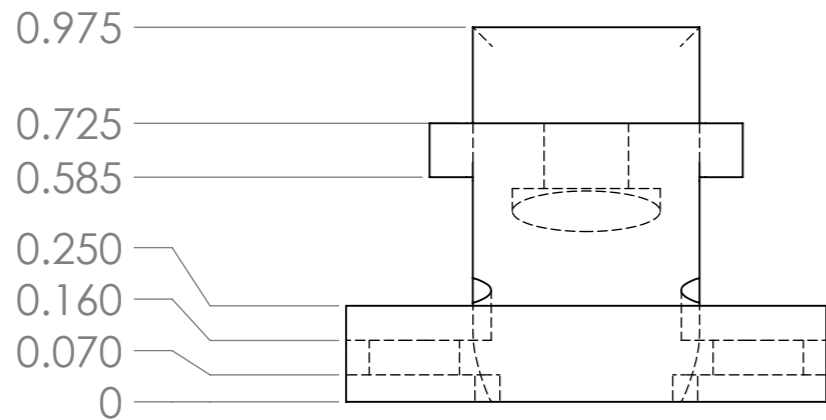
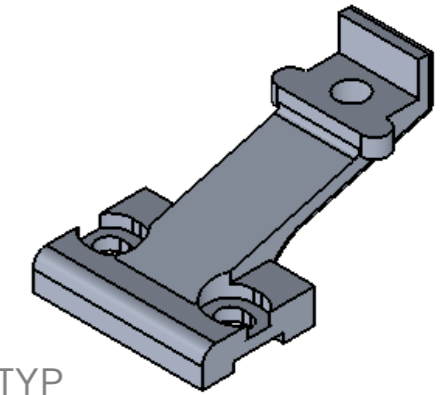

UNLESS OTHERWISE SPECIFIED: DIMENSIONS ARE IN MILLIMETERS SURFACE FINISH: TOLERANCES: LINEAR: ANGULAR:			FINISH: CLEAN		DEBURR AND BREAK SHARP EDGES		DO NOT SCALE DRAWING		REVISION			
							RCMP-GRC					
							TITLE: 40mmlightmount					
							MATERIAL: 7075-T6				DWG NO.	
							WEIGHT:		SCALE:2:1		SHEET 1 OF 1	
DRAWN		NAME		SIGNATURE		DATE				A3		
CHK'D												
APPV'D												
MFG												
Q.A												