



Royal Canadian Mounted Police
Gendarmerie royale du Canada

Doc. no: G.S. 1045-340
Date: 2018-07-10

Specification

Epaulettes, Rank (Woven Type)

This document has 26 pages including the drawings.

This document was created in English.

The document is available in English and French.

English/Anglais
Français/French

The photograph on this page is for reference only.

RCMP VIEWING SAMPLE

A viewing sample, when available, will be supplied to the successful bidder.

This will be used for the guidance of the manufacturer in all factors not covered by this specification or referred to therein. Variation from the specification may appear in the sample in which case the specification must govern.

It may be obtained from:

Royal Canadian Mounted Police
ATTN: Uniform & Equipment Program
(440 Coventry Road, Warehouse Building)
73 Leikin Drive
Ottawa, Ontario
K1A 0R2

It will be sent “prepaid” and is to be returned “prepaid”.

The viewing sample must be returned to the RCMP in the same condition as received by the manufacturer. Lost or damaged viewing samples must be replaced by an identical item or the RCMP must be reimbursed for the cost of an acceptable replacement.

SPECIFICATION
Epaulettes, Rank, Woven

1. Definition

1.1 This specification must govern the manufacture and inspection of Epaulettes, Rank, Woven. The specific items covered under this specification with stock numbers are as follows:

- i. 3360-300 – Epaulette, Rank, Corporal
- ii. 3360-407 – Epaulette, Rank, Sergeant
- iii. 3360-504 – Epaulette, Rank, Staff Sergeant
- iv. 3370-100 – Epaulette, Rank, Staff Sergeant Major
- v. 3370-208 – Epaulette, Rank, Sergeant Major
- vi. 3370-305 – Epaulette, Rank, Corps Sergeant Major
- vii. 3362-305 – Epaulette, Rank, Corporal, Subdued
- viii. 3362-412 – Epaulette, Rank, Sergeant, Subdued
- ix. 3362-508 – Epaulette, Rank, Staff Sergeant, Subdued
- x. 3372-209 – Epaulette, Rank, Staff Sergeant Major, Subdued
- xi. 3372-101 – Epaulette, Rank, Sergeant Major, Subdued
- xii. 3372-306 – Epaulette, Rank, Corps Sergeant Major, Subdued
- xiii. 4662-051 – Epaulette, Rank, Inspector, Subdued
- xiv. 4662-048 – Epaulette, Rank, Superintendent, Subdued
- xv. 4662-033 – Epaulette, Rank, Chief Superintendent, Subdued
- xvi. 3360-100 – Epaulette, Rank, Blank

1.2 This specification, viewing sample, drawing or other information issued in connection therewith, may only be used for specific enquiries, solicitations, or orders placed on behalf of the Royal Canadian Mounted Police.

1.3 This specification supersedes all previous specifications for Epaulettes, Rank, Woven.

1.4 This specification has been translated into French from this original English language document

2. Applicable Specifications

2.1 The following publications are applicable to this specification and to the issues in effect on the date of the solicitation, unless otherwise specified.

- 2.2 **Canadian General Standards Board (CAN/CGSB);**
4.2 No. 18.3-97 (R2010) Textile test methods – Colourfastness to Artificial Light: Xenon Arc Fading Lamp Test
4.2 No. 19.1-2004 (R2013) Textile test methods – Colourfastness to washing, Accelerated test
4.2 No. 22-2004 Textile test methods – Colourfastness to rubbing (Crocking)
- 2.3 **American Association of Textile Chemists and Colorists (AATCC)**
132-2013 Colorfastness to Dry-cleaning
- 2.4 **International Standards Organization (ISO)**
105-B02:2014 Colour fastness to artificial light: Xenon arc fading lamp test
105-D01:2010 Colour fastness to drycleaning using perchloroethylene solvent
- 2.5 **US Government Mil-Spec**
A-A-50199A Thread, Polyester Core, Cotton or Polyester-Covered.

3. **General Requirements**

- 3.1 The article or material covered by this specification must be free from material and manufacturing defects that may affect its appearance or serviceability. In all particulars not covered by this specification or contract documents, production must be equivalent in all respects to the viewing sample.
- 3.2 **Design** – The epaulettes must be designed in accordance with the drawings attached and forming part of this specification; and the viewing sample.

4. **Detail Requirements**

4.1 **Components**

- 4.1.1 **Yarn** – All yarns, when woven, must meet the requirements outlined in Table I.

- 4.1.1.1 **Warp Yarn** – The warp yarn must be 100% polyester, between 90 to 150 denier, black in colour.
- 4.1.1.2 **Ground Yarns** – The ground yarns must be 100% polyester, between 90 to 150 denier, navy blue or royal blue in colour as applicable.
- 4.1.1.3 **Design Yarns** – The design yarns must be 100% polyester, between 50 to 100 denier, in a combination of gold, royal blue, red, white, green, purple, gray, and black colours as applicable. The colour reference must be as indicated in Table I.
- 4.1.2 **Thread, Stitching** – The thread must be polyester wrap, polyester core, Tex 40, Type II of matching colour to the shell material, meeting U.S. government standard A-A-50199A.
- 4.2 **Size and Dimensions** – The Epaulettes, Woven must be sized and dimensioned as per the drawings.
- 4.3 **Construction**
- 4.3.1 **Weaving** – The weaving must be 1 x 3 right hand twill. All design yarns must be bound down. The design yarns must not show through the ground yarns except as part of the design itself. The epaulettes must be similar, respective to their design and size.
- 4.3.2 **Finish** – All epaulettes must have a resin hand building finish. The epaulettes must be interlined, the edges serged or sealed, then sewn and pressed forming a sleeve with the insignia properly centered as per viewing sample.

5. **Quality Assurance Provisions**

- 5.1 **Responsibility for Inspection** – Unless otherwise stipulated in the contract, it is the prime contractor's responsibility to satisfy the RCMP, Uniform and Equipment Program that the material and services being supplied conform to this tender, contract and specification. This must be accomplished by performing the tests specified in this specification. The contractor must use a commercial testing establishment acceptable to the RCMP, Uniform and Equipment Program.
- 5.2 The RCMP, Uniform and Equipment Program reserves the right to perform any inspection considered necessary to ensure the material and services conform to the

specified requirements. Inspection may be done during manufacture and is subject to testing and approval by the RCMP Uniform and Equipment Program. Imperfections must be assessed in accordance with current RCMP practice. If the cloth is found to be inferior to the viewing sample or not in accordance with this specification, the entire delivery may be rejected. The entire delivery may also be rejected if it is found that materials previously rejected due to non-repairable defects are redelivered for inspection.

- 5.3 The contractor will be promptly notified when any articles are not accepted and such articles will be returned at the contractor's risk and expense.

TABLE I
Properties of Epaulettes, Rank, Woven

		Requirements	Test Method
1	Ground Colour	Navy Blue	To match colour sample
2	Design Colour (s)	As applicable:	
		Gold	Pantone 1245 C
		Royal Blue	Pantone 7690 C
		Red	Pantone 7621 C
		Green	Pantone 3415 C
		Grey	Pantone Cool Grey 11 C
		Black	-
		White	-
	Purple	Pantone 513 C	<i>For item 3370-305, CSM epaulette only</i>
3	Fibre Content	100% Polyester	
4	Colourfastness to Light – Xenon Arc Method	Equal to or better than L4 using Method 3	<ul style="list-style-type: none"> • CAN/CGSB-4.2 No. 18.3-97 (R2010) OR • ISO 105-B02:2014
5	Colourfastness to Crocking	Dry: Grey Scale 4-5 or better Wet: Grey Scale 3-4 or better	<ul style="list-style-type: none"> • CAN/CGSB-4.2 No. 22-2004 (R2013)
6	Colourfastness to Washing	Colour Change: Grey Scale 4 or better Staining: Grey Scale 4 or better	<ul style="list-style-type: none"> • CAN/CGSB-4.2 No. 19.1-2004 (R2013) Test No.1
7	Colourfastness to Dry Cleaning	Colour Change: Grey Scale 4 or better Staining: Grey Scale 4 or better	<ul style="list-style-type: none"> • AATCC 132-2013 OR • ISO 105-D01:2010

Drawing 1

G.S. 1045-340

Epaulette, Rank, Woven
#3360-300 Epaulette, Rank, Corporal

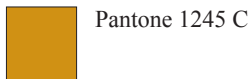
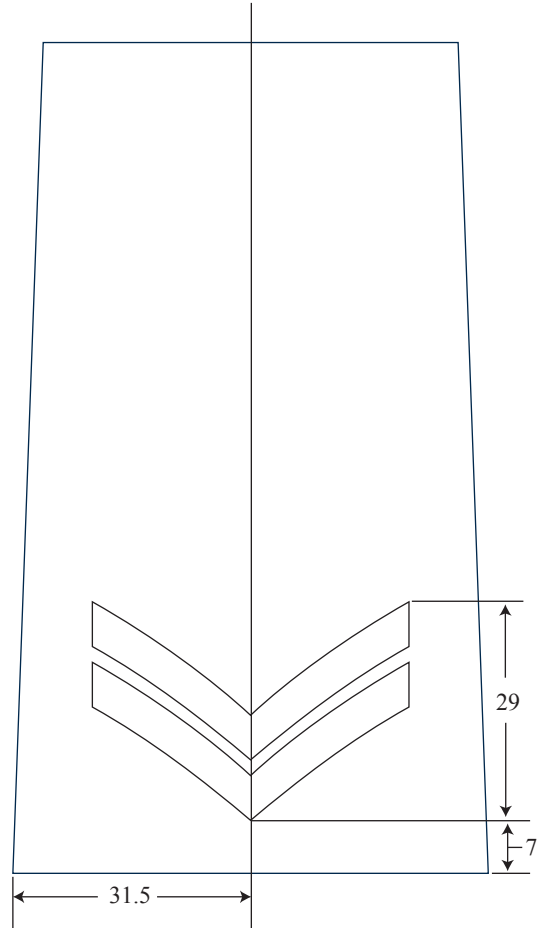

All Measurements in millimetres
± 2 mm tolerance acceptable unless otherwise indicated.
ARTWORK TO SCALE IN ADOBE ILLUSTRATOR
FILE IS AVAILABLE FROM TECHNICAL AUTHORITY
FOR USE ON AUTHORIZED CONTRACTS ONLY

Drawing 2

G.S. 1045-340

Epaulette, Rank, Woven
#3360-407 Epaulette, Rank, Sergeant

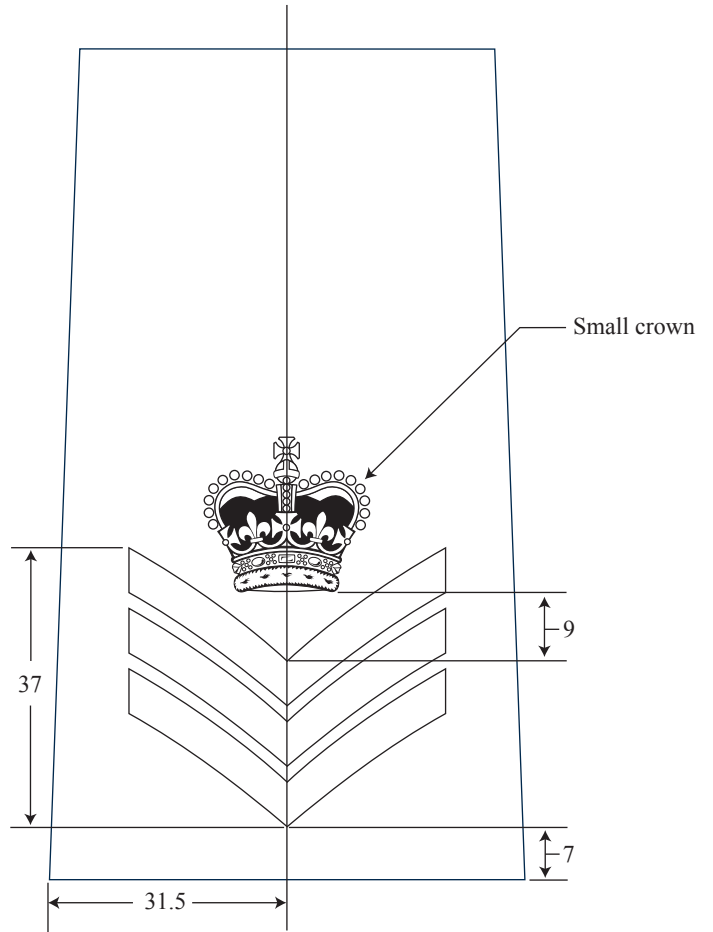

Colours



Pantone 1245 C



Pantone 7621 C



Pantone 3415 C



Pantone 7690 C



White



Black

All Measurements in millimetres

± 2 mm tolerance acceptable unless otherwise indicated.

ARTWORK TO SCALE IN ADOBE ILLUSTRATOR

FILE IS AVAILABLE FROM TECHNICAL AUTHORITY

FOR USE ON AUTHORIZED CONTRACTS ONLY

Drawing 3

G.S. 1045-340

Epaulette, Rank, Woven
#3360-504 Epaulette, Rank, Staff Sergeant

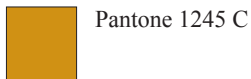
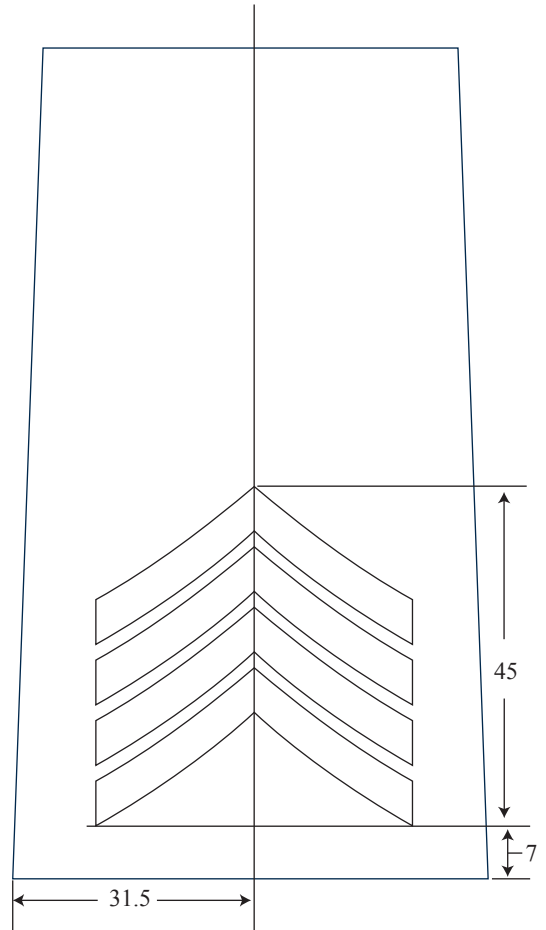

All Measurements in millimetres
± 2 mm tolerance acceptable unless otherwise indicated.
ARTWORK TO SCALE IN ADOBE ILLUSTRATOR
FILE IS AVAILABLE FROM TECHNICAL AUTHORITY
FOR USE ON AUTHORIZED CONTRACTS ONLY

Drawing 4

G.S. 1045-340

Epaulette, Rank, Woven
#3370-100 Epaulette, Rank, Staff Sergeant Major

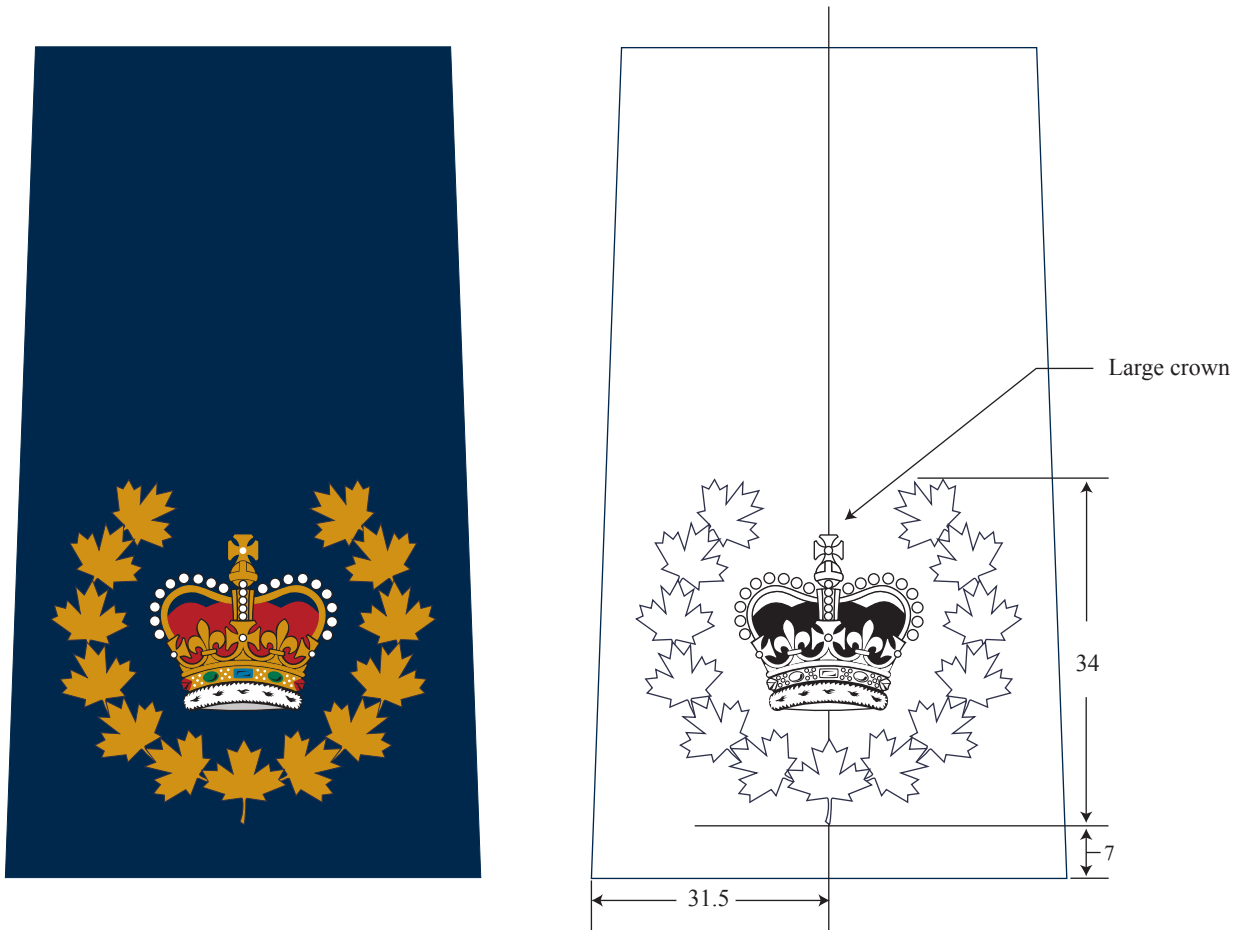

Colours

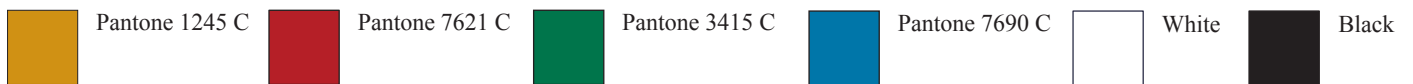

All Measurements in millimetres

± 2 mm tolerance acceptable unless otherwise indicated.

ARTWORK TO SCALE IN ADOBE ILLUSTRATOR
FILE IS AVAILABLE FROM TECHNICAL AUTHORITY
FOR USE ON AUTHORIZED CONTRACTS ONLY

Drawing 5

G.S. 1045-340

Epaulette, Rank, Woven
#3370-208 Epaulette, Rank, Sergeant Major

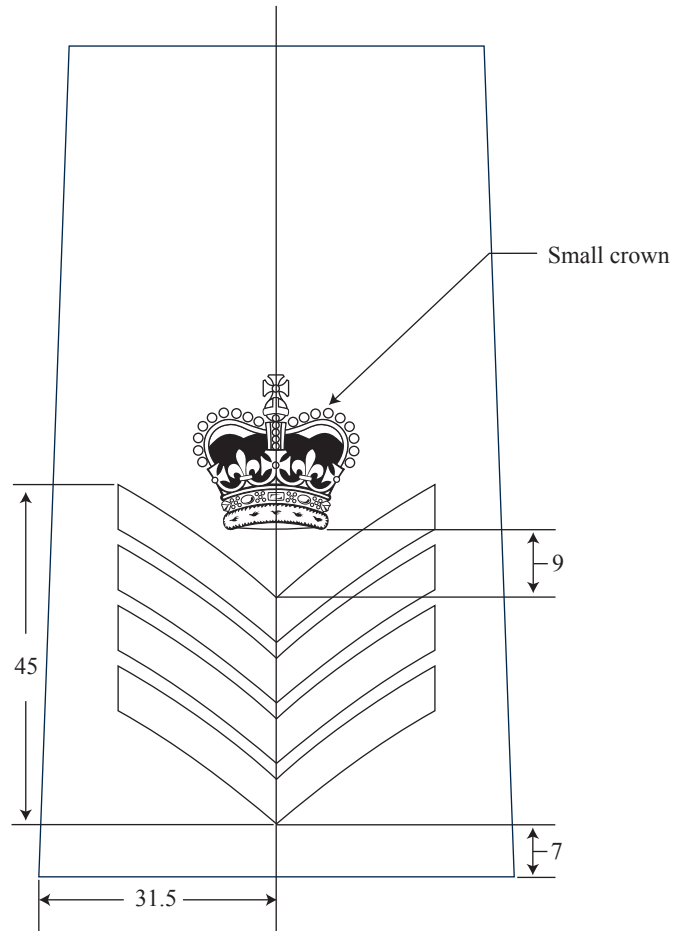

Colours



Pantone 1245 C



Pantone 7621 C



Pantone 3415 C



Pantone 7690 C



White



Black

All Measurements in millimetres
± 2 mm tolerance acceptable unless otherwise indicated.
ARTWORK TO SCALE IN ADOBE ILLUSTRATOR
FILE IS AVAILABLE FROM TECHNICAL AUTHORITY
FOR USE ON AUTHORIZED CONTRACTS ONLY

Drawing 6

G.S. 1045-340

Epaulette, Rank, Woven
#3370-305 Epaulette, Rank, Corps Sergeant Major



Colours

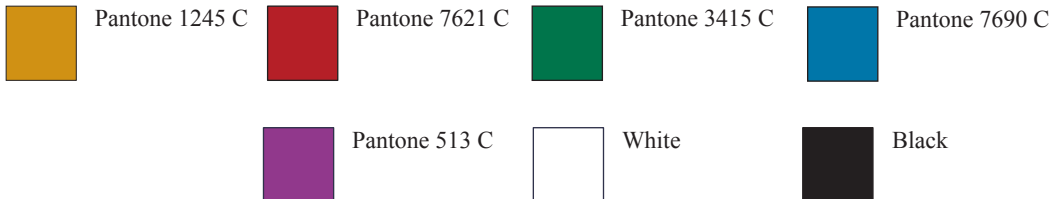

All Measurements in millimetres
± 2 mm tolerance acceptable unless otherwise indicated.
ARTWORK TO SCALE IN ADOBE ILLUSTRATOR
FILE IS AVAILABLE FROM TECHNICAL AUTHORITY
FOR USE ON AUTHORIZED CONTRACTS ONLY

Drawing 7

G.S. 1045-340

Epaulette, Rank, Woven
#3362-305 Epaulette, Rank, Corporal, Subdued

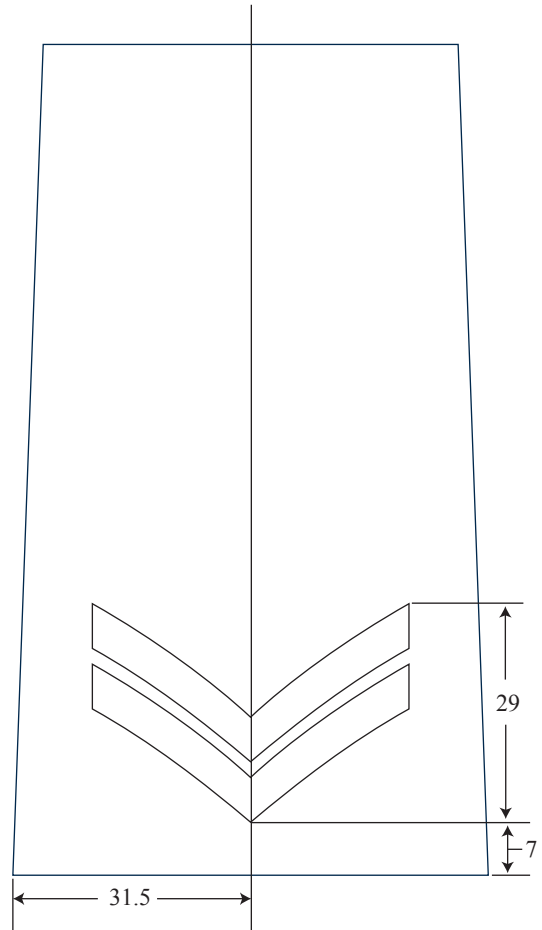

Pantone Cool Gray 11C

All Measurements in millimetres
± 2 mm tolerance acceptable unless otherwise indicated.
ARTWORK TO SCALE IN ADOBE ILLUSTRATOR
FILE IS AVAILABLE FROM TECHNICAL AUTHORITY
FOR USE ON AUTHORIZED CONTRACTS ONLY

Drawing 8

G.S. 1045-340

Epaulette, Rank, Woven
#3362-412 Epaulette, Rank, Sergeant, Subdued

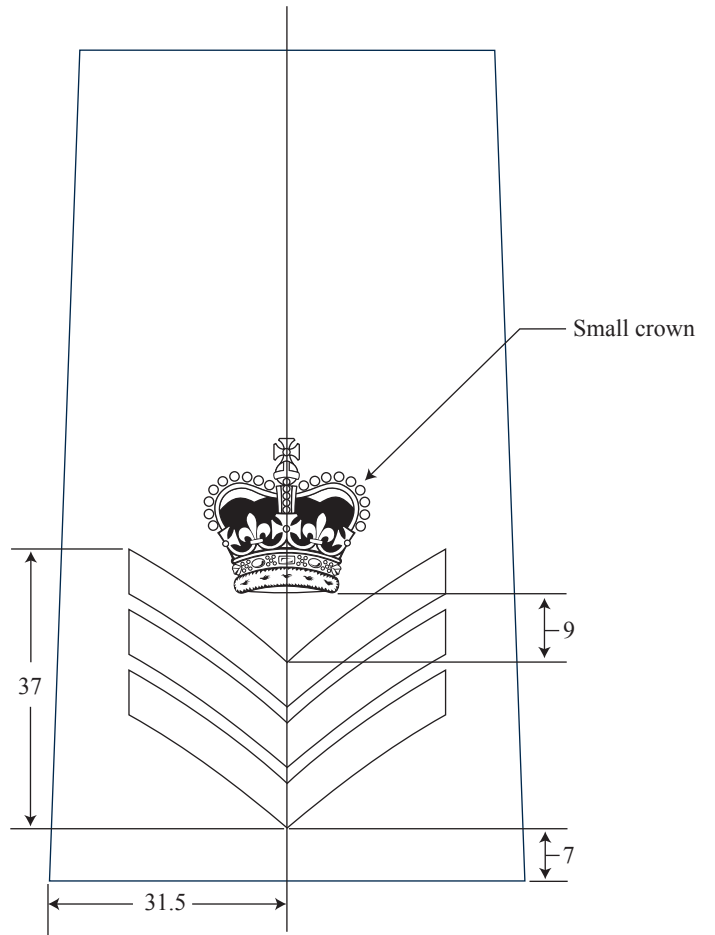

All Measurements in millimetres
± 2 mm tolerance acceptable unless otherwise indicated.
ARTWORK TO SCALE IN ADOBE ILLUSTRATOR
FILE IS AVAILABLE FROM TECHNICAL AUTHORITY
FOR USE ON AUTHORIZED CONTRACTS ONLY

Drawing 9

G.S. 1045-340

Epaulette, Rank, Woven
#3362-508 Epaulette, Rank, Staff Sergeant, Subdued

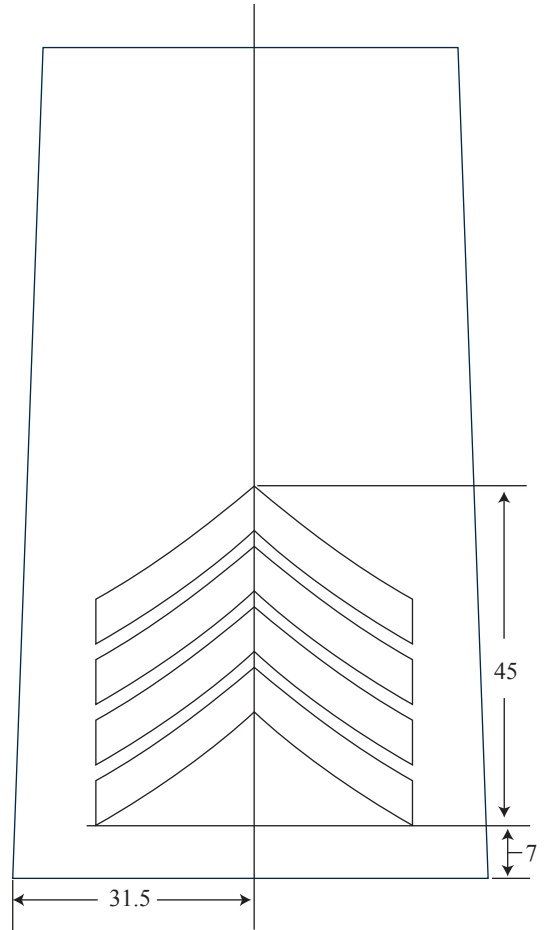

Pantone Cool Gray 11C

All Measurements in millimetres
± 2 mm tolerance acceptable unless otherwise indicated.
ARTWORK TO SCALE IN ADOBE ILLUSTRATOR
FILE IS AVAILABLE FROM TECHNICAL AUTHORITY
FOR USE ON AUTHORIZED CONTRACTS ONLY

Drawing 10

G.S. 1045-340

Epaulette, Rank, Woven
#3372-209 Epaulette, Rank, Staff Sergeant Major, Subdued

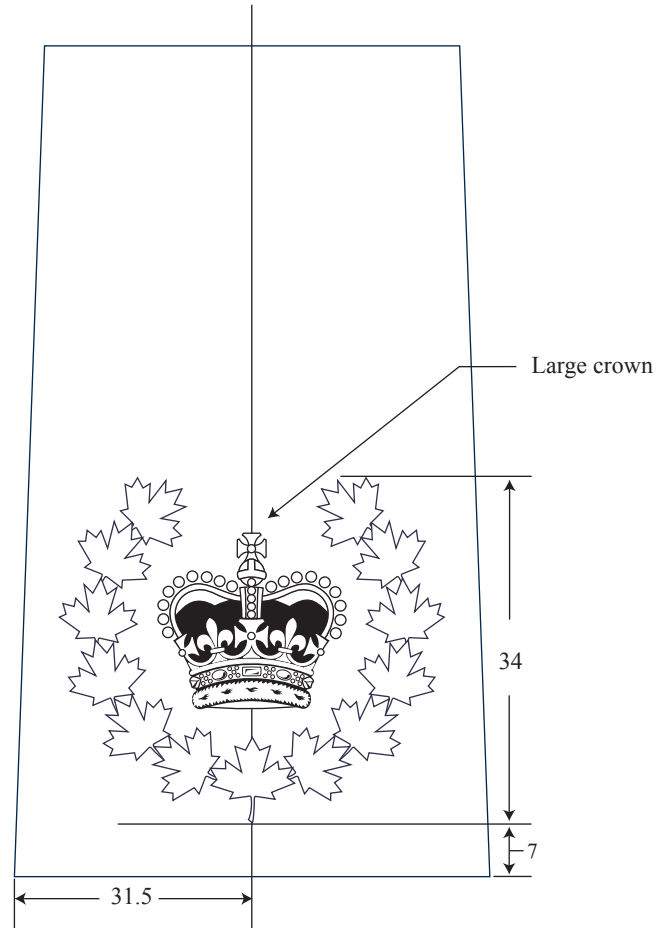

Pantone Cool Gray 11C

All Measurements in millimetres
± 2 mm tolerance acceptable unless otherwise indicated.
ARTWORK TO SCALE IN ADOBE ILLUSTRATOR
FILE IS AVAILABLE FROM TECHNICAL AUTHORITY
FOR USE ON AUTHORIZED CONTRACTS ONLY

Drawing 11

G.S. 1045-340

Epaulette, Rank, Woven
#3372-101 Epaulette, Rank, Sergeant Major, Subdued

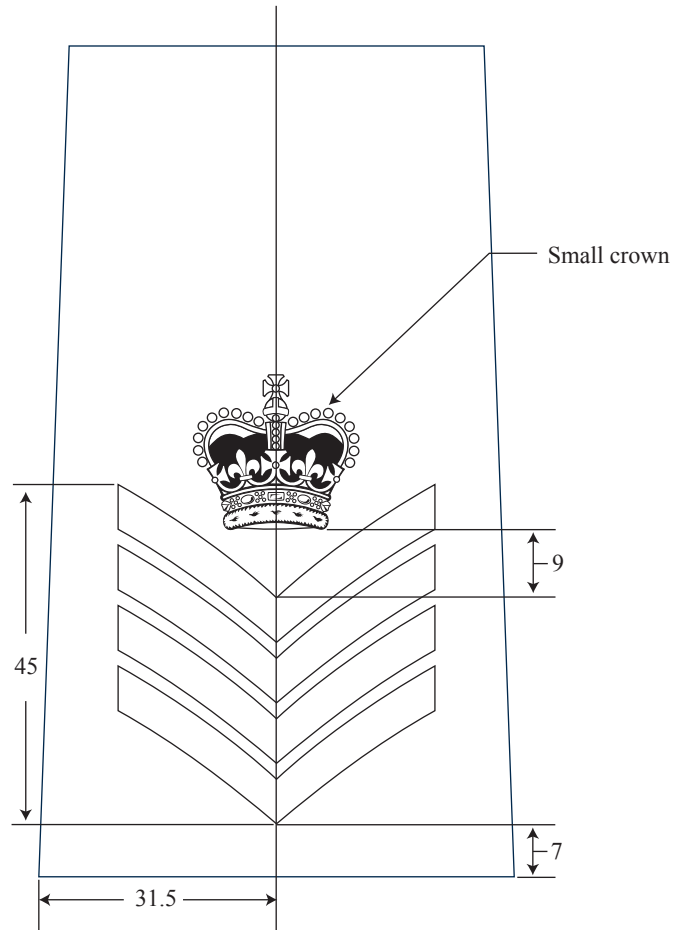

Pantone Cool Gray 11C

All Measurements in millimetres
± 2 mm tolerance acceptable unless otherwise indicated.
ARTWORK TO SCALE IN ADOBE ILLUSTRATOR
FILE IS AVAILABLE FROM TECHNICAL AUTHORITY
FOR USE ON AUTHORIZED CONTRACTS ONLY

Drawing 12

G.S. 1045-340

Epaulette, Rank, Woven
#3372-306 Epaulette, Rank, Corps Sergeant Major, Subdued



Pantone Cool Gray 11C

All Measurements in millimetres
± 2 mm tolerance acceptable unless otherwise indicated.
ARTWORK TO SCALE IN ADOBE ILLUSTRATOR
FILE IS AVAILABLE FROM TECHNICAL AUTHORITY
FOR USE ON AUTHORIZED CONTRACTS ONLY

Drawing 13

G.S. 1045-340

Epaulette, Rank, Woven
#4662-051 Epaulette, Rank, Inspector, Subdued

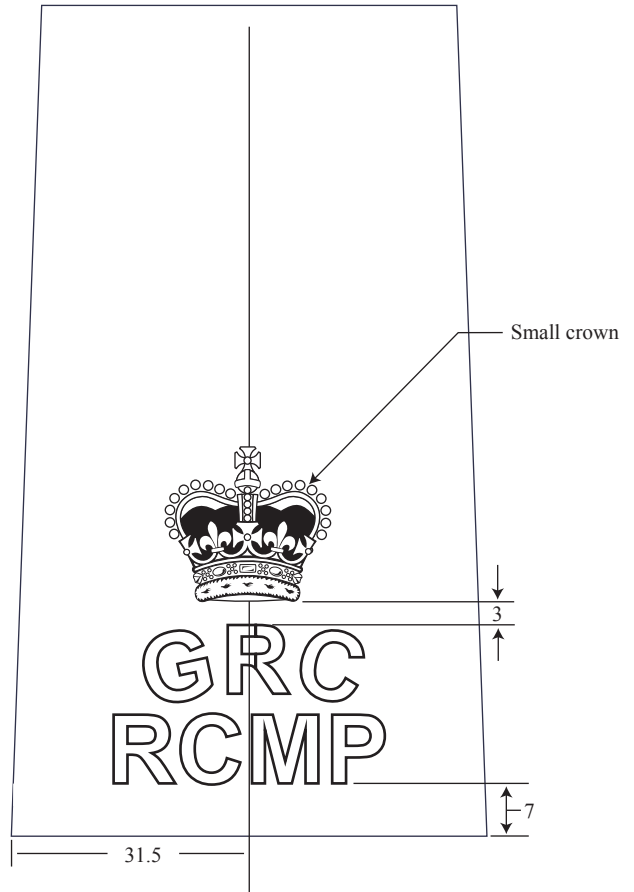

Pantone Cool Gray 11C

All Measurements in millimetres
± 2 mm tolerance acceptable unless otherwise indicated.
ARTWORK TO SCALE IN ADOBE ILLUSTRATOR
FILE IS AVAILABLE FROM TECHNICAL AUTHORITY
FOR USE ON AUTHORIZED CONTRACTS ONLY

Drawing 14

G.S. 1045-340

Epaulette, Rank, Woven
#4662-048 Epaulette, Rank, Superintendent, Subdued

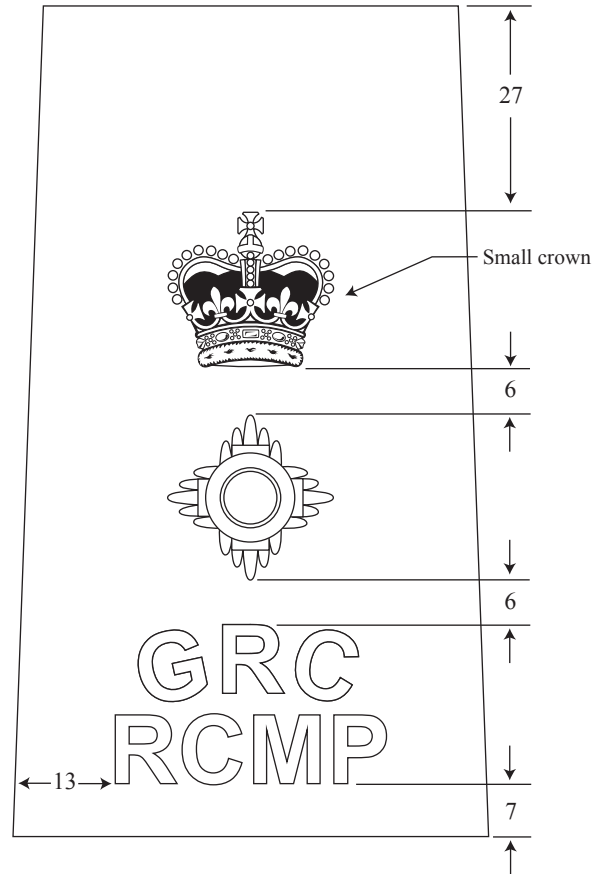

Pantone Cool Gray 11C

All Measurements in millimetres
± 2 mm tolerance acceptable unless otherwise indicated.
ARTWORK TO SCALE IN ADOBE ILLUSTRATOR
FILE IS AVAILABLE FROM TECHNICAL AUTHORITY
FOR USE ON AUTHORIZED CONTRACTS ONLY

Drawing 15

G.S. 1045-340

Epaulette, Rank, Woven
#4662-033 Epaulette, Rank, Chief Superintendent, Subdued

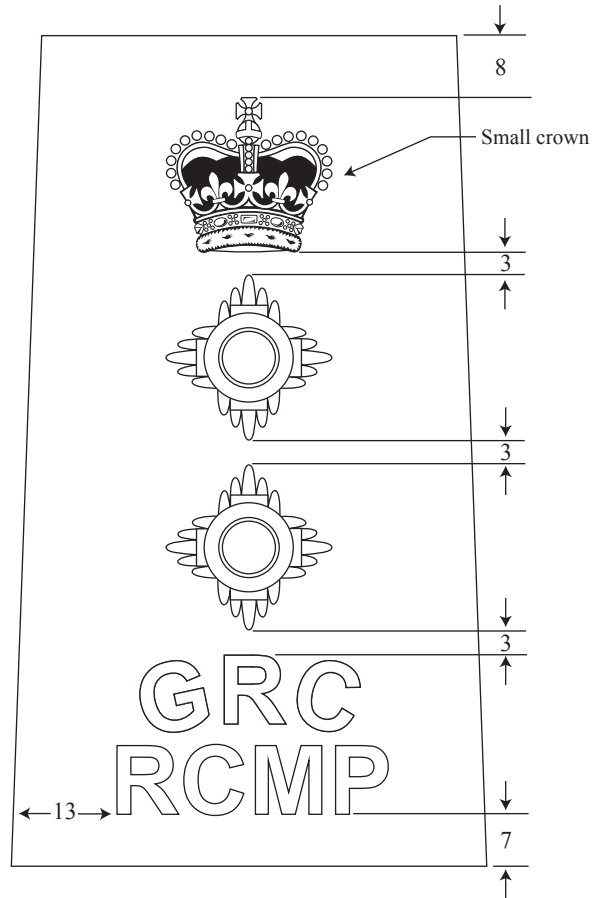

Pantone Cool Gray 11C

All Measurements in millimetres
± 2 mm tolerance acceptable unless otherwise indicated.
ARTWORK TO SCALE IN ADOBE ILLUSTRATOR
FILE IS AVAILABLE FROM TECHNICAL AUTHORITY
FOR USE ON AUTHORIZED CONTRACTS ONLY

Drawing 16

G.S. 1045-340

Epaulette, Rank, Woven
#3360-100 Epaulette, Rank, Blank

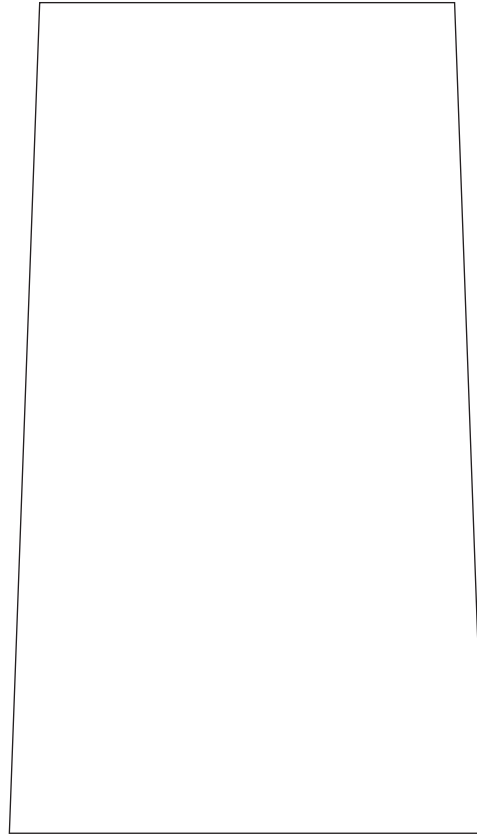
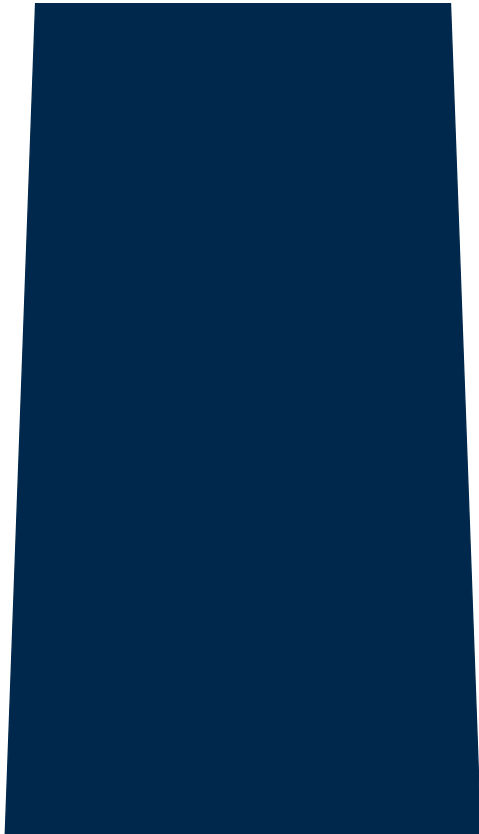

All Measurements in millimetres
± 2 mm tolerance acceptable unless otherwise indicated.
ARTWORK TO SCALE IN ADOBE ILLUSTRATOR
FILE IS AVAILABLE FROM TECHNICAL AUTHORITY
FOR USE ON AUTHORIZED CONTRACTS ONLY

Drawing 17

G.S. 1045-340

Epaulette, Rank, Woven
Epaulette Details

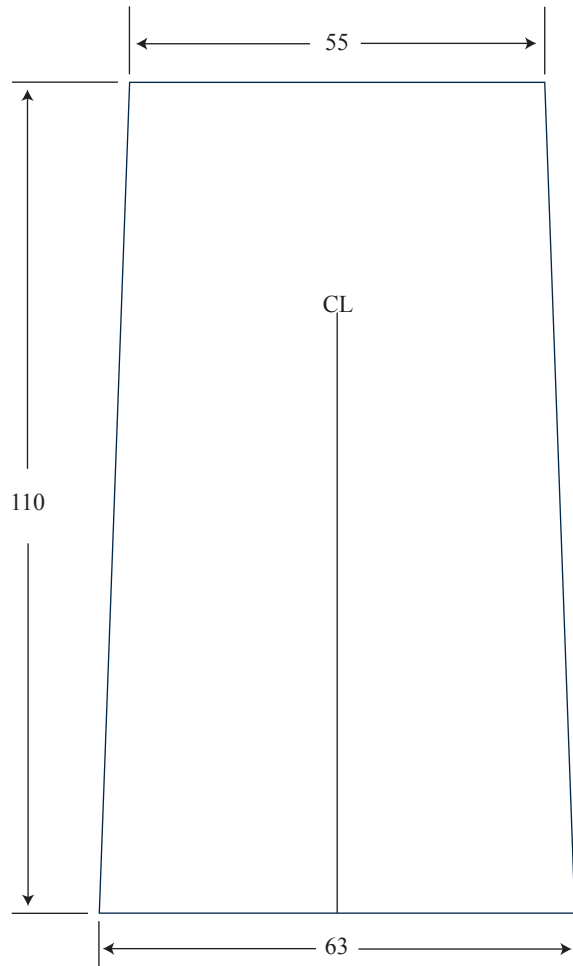

Epaulette Finished Dimensions

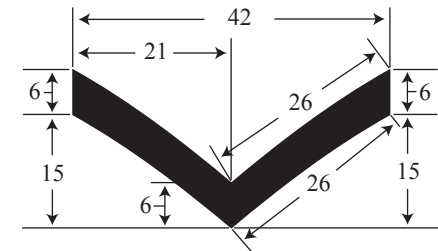
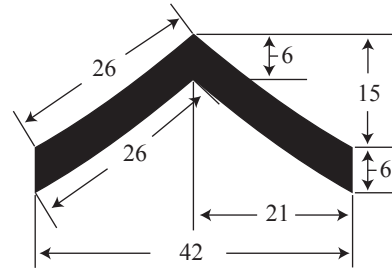

Single Chevrons

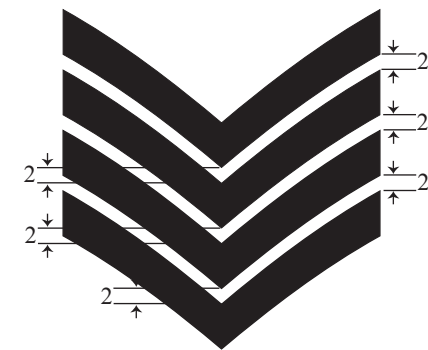
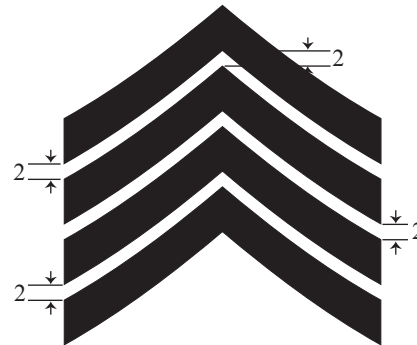

Multiple Chevrons

All Measurements in millimetres
± 2 mm tolerance acceptable unless otherwise indicated.
ARTWORK TO SCALE IN ADOBE ILLUSTRATOR
FILE IS AVAILABLE FROM TECHNICAL AUTHORITY
FOR USE ON AUTHORIZED CONTRACTS ONLY

Drawing 18

G.S. 1045-340

Epaulette, Rank, Woven
Epaulette Details

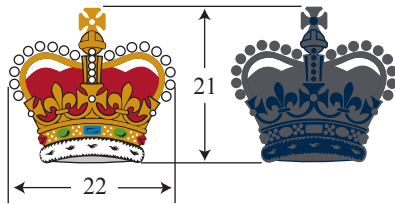

Small Crown Detail



Lettering

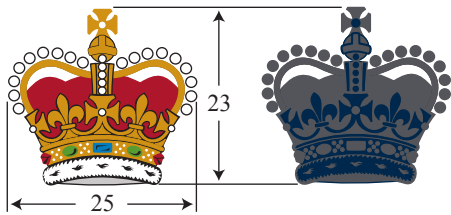

Large Crown Detail

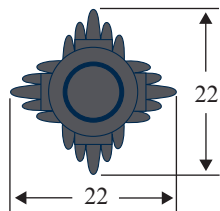

Pip Detail

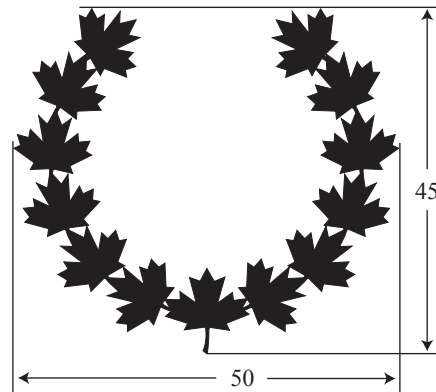

Leaves for Staff Sergeant Major

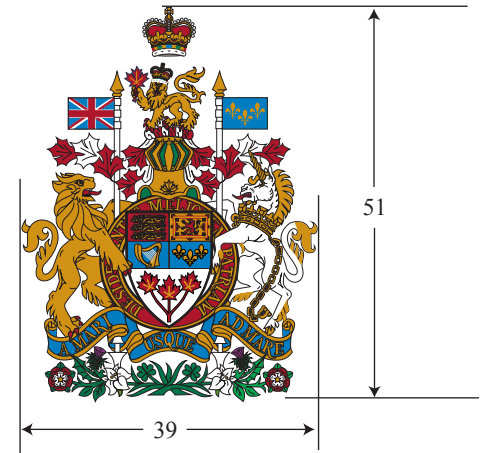

Coat of Arms for Corps Sergeant Major

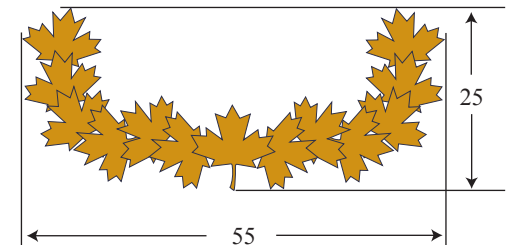

Leaves for Corps Sergeant Major

All Measurements in millimetres
± 2 mm tolerance acceptable unless otherwise indicated.
ARTWORK TO SCALE IN ADOBE ILLUSTRATOR
FILE IS AVAILABLE FROM TECHNICAL AUTHORITY
FOR USE ON AUTHORIZED CONTRACTS ONLY