

PLAN - TOP

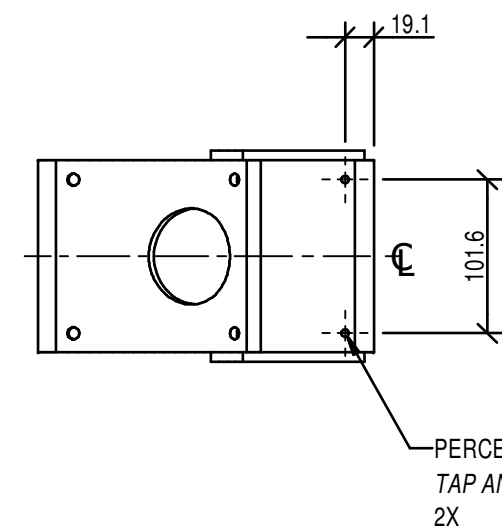

PROFIL - PROFILE

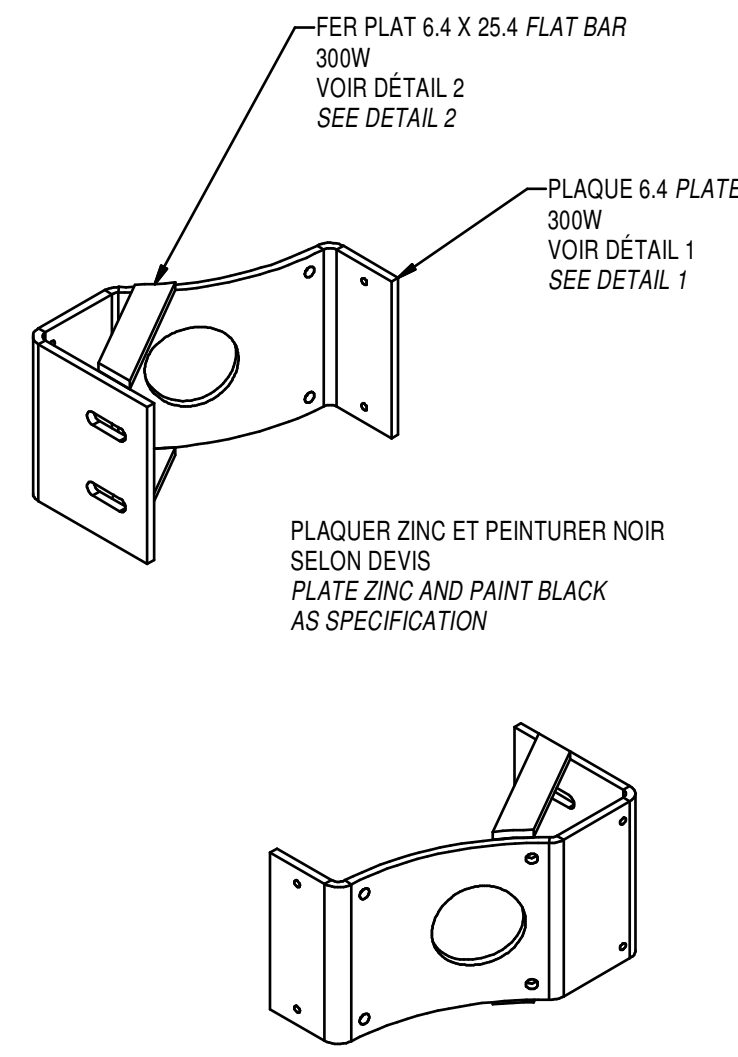
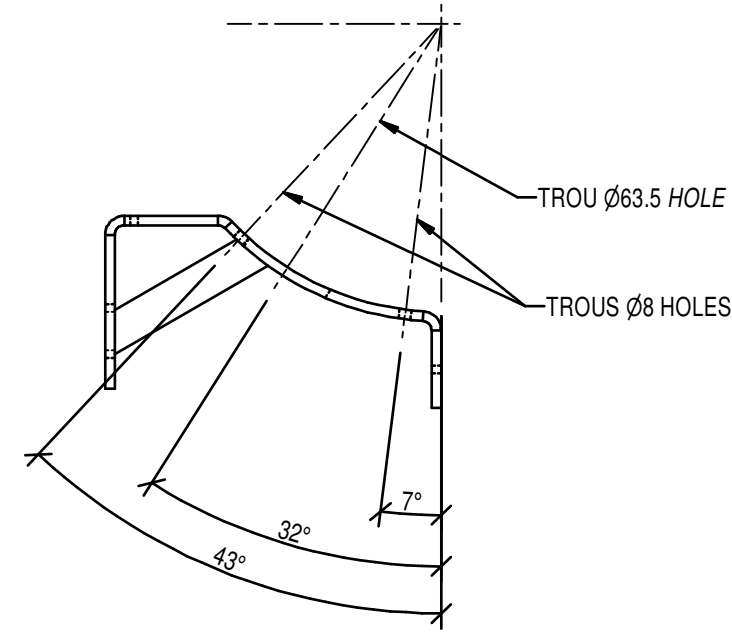
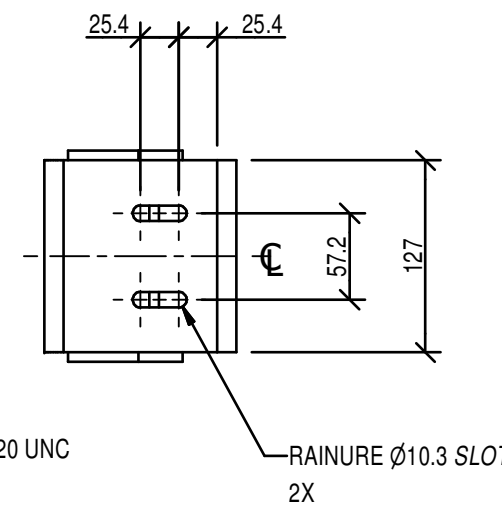

ÉLEVATION - ELEVATION

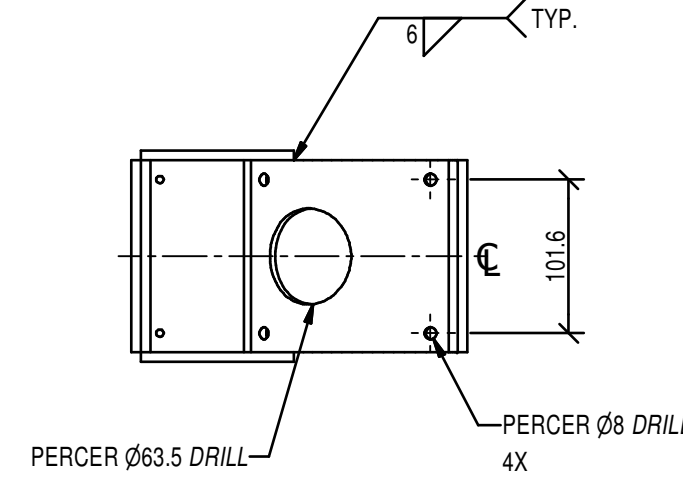

PROFIL - PROFILE

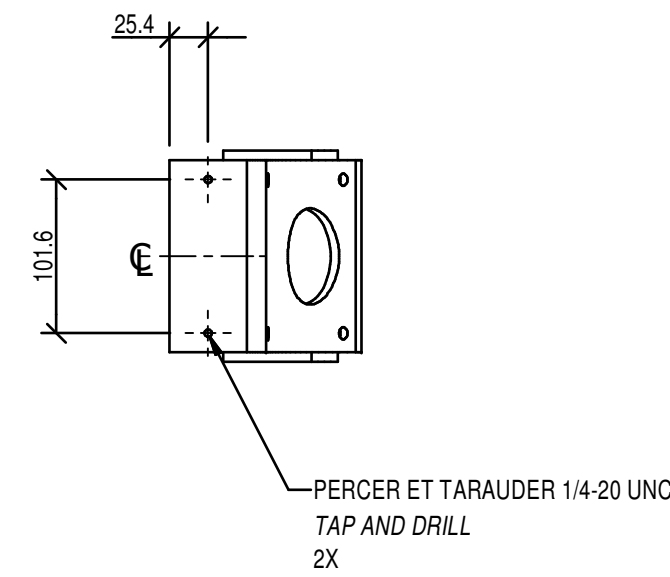

ÉLEVATION - ELEVATION

SUPPORT DU FREIN
BRAKE SUPPORT

ÉCH. - SCALE 1: 5

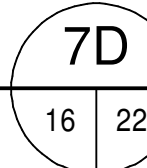

CÔTÉ DROIT : TEL QUEL
CÔTÉ GAUCHE : OPPOSÉ
RIGHT SIDE : AS SHOWN
LEFT SIDE : OPPOSITE

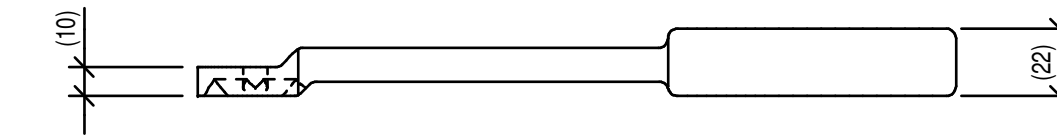
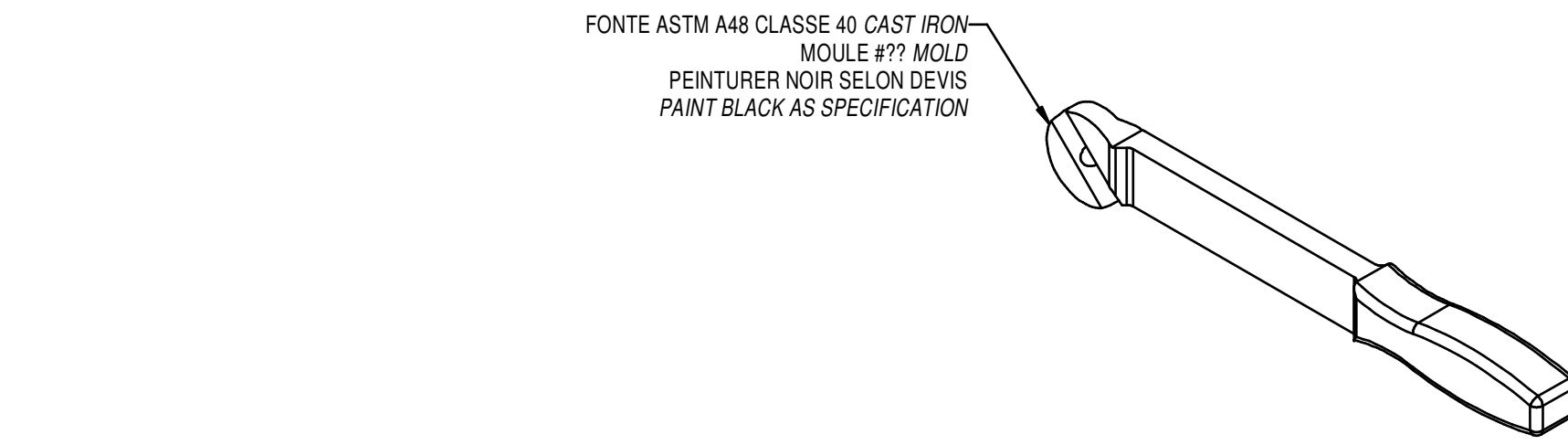

PLAN - TOP

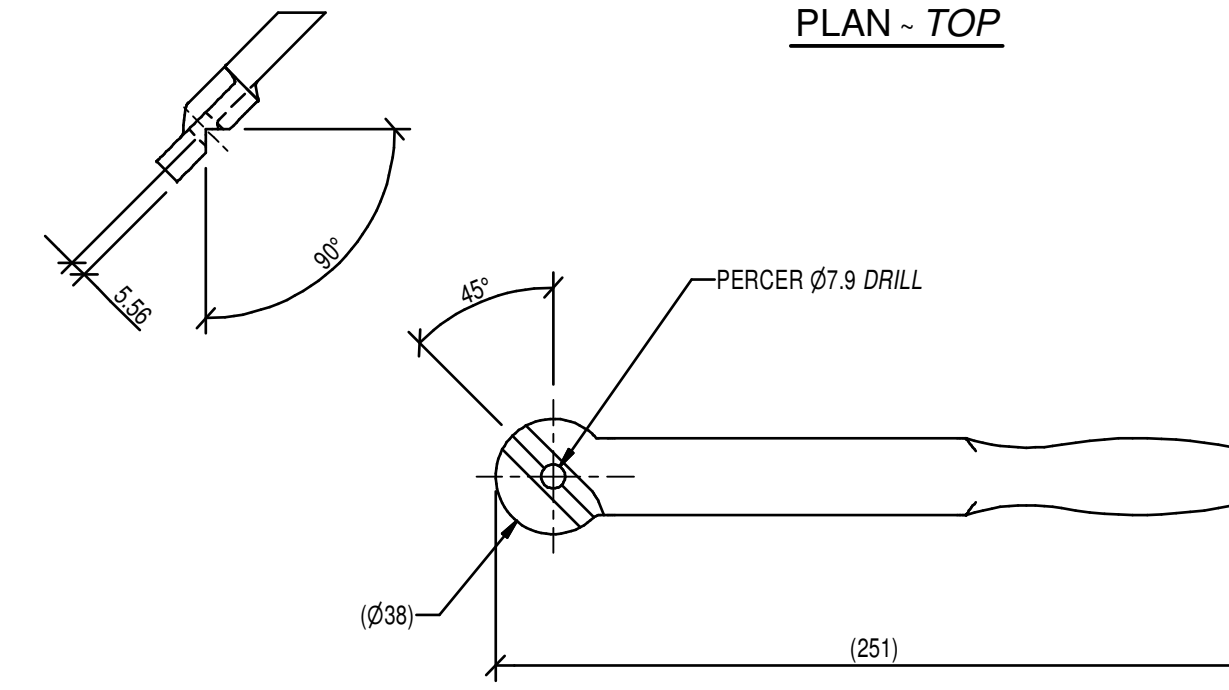

ÉLEVATION - ELEVATION

POIGNÉE DU FREIN
BRAKE HANDLE

ÉCH. - SCALE 1: 2.5

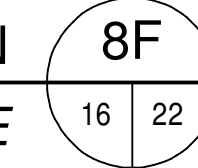

CÔTÉ DROIT : TEL QUEL
CÔTÉ GAUCHE : OPPOSÉ
RIGHT SIDE : AS SHOWN
LEFT SIDE : OPPOSITE

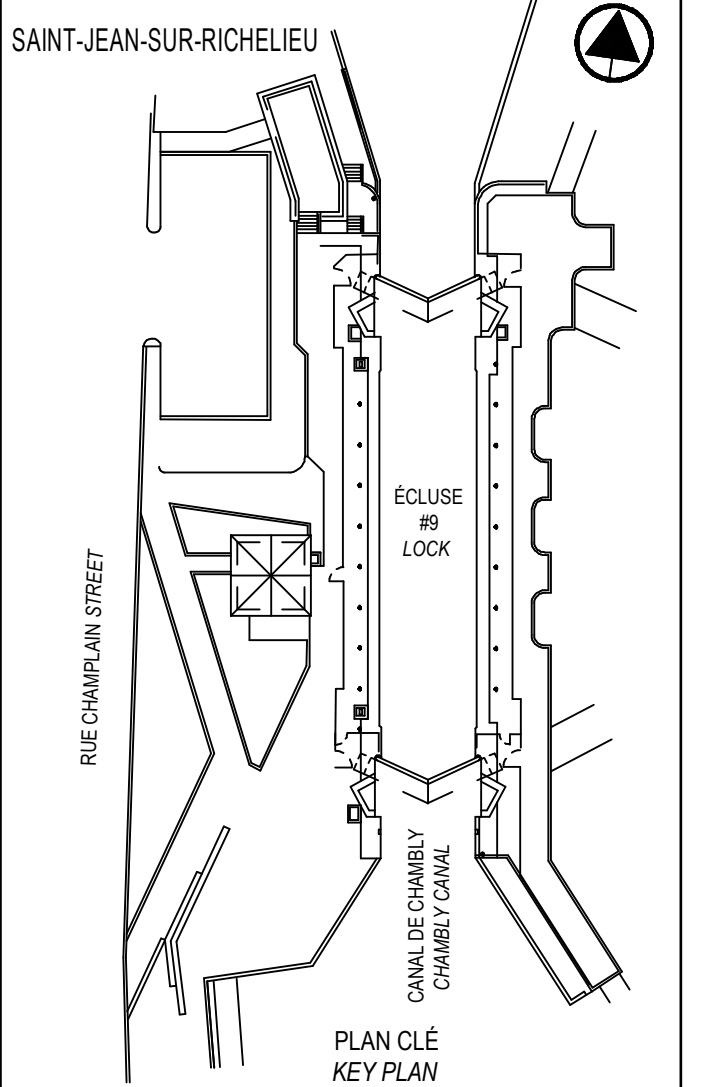

SCEAUX SEALS

PROTECTEUR DU FREIN
BRAKE PROTECTOR

ÉCH. - SCALE 1: 5

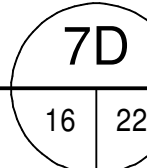

CÔTÉ DROIT : TEL QUEL
CÔTÉ GAUCHE : OPPOSÉ
RIGHT SIDE : AS SHOWN
LEFT SIDE : OPPOSITE

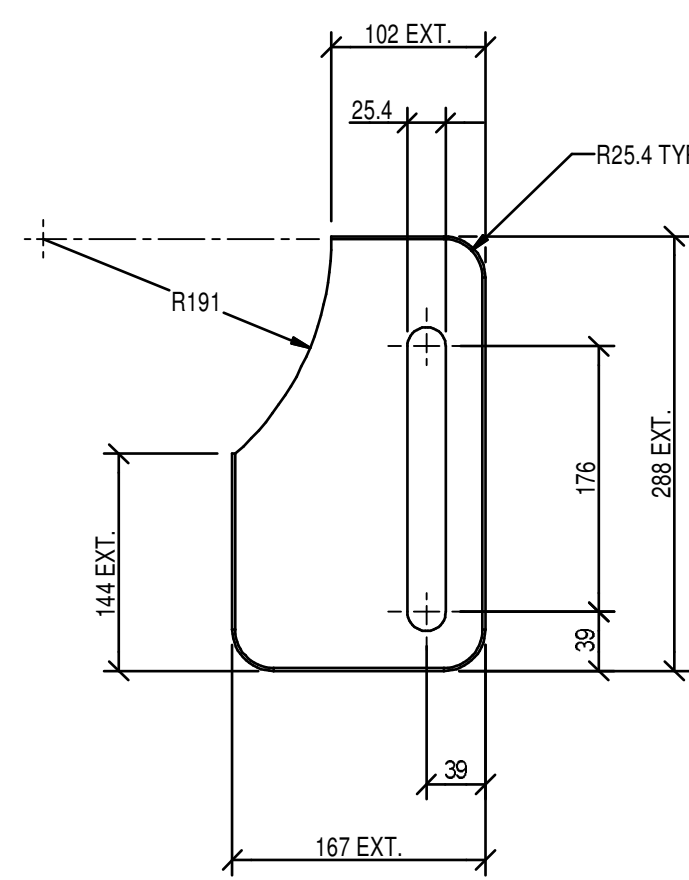

PLAN - TOP

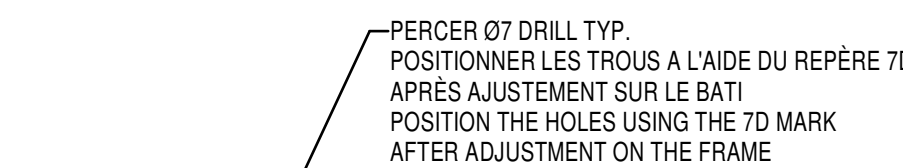
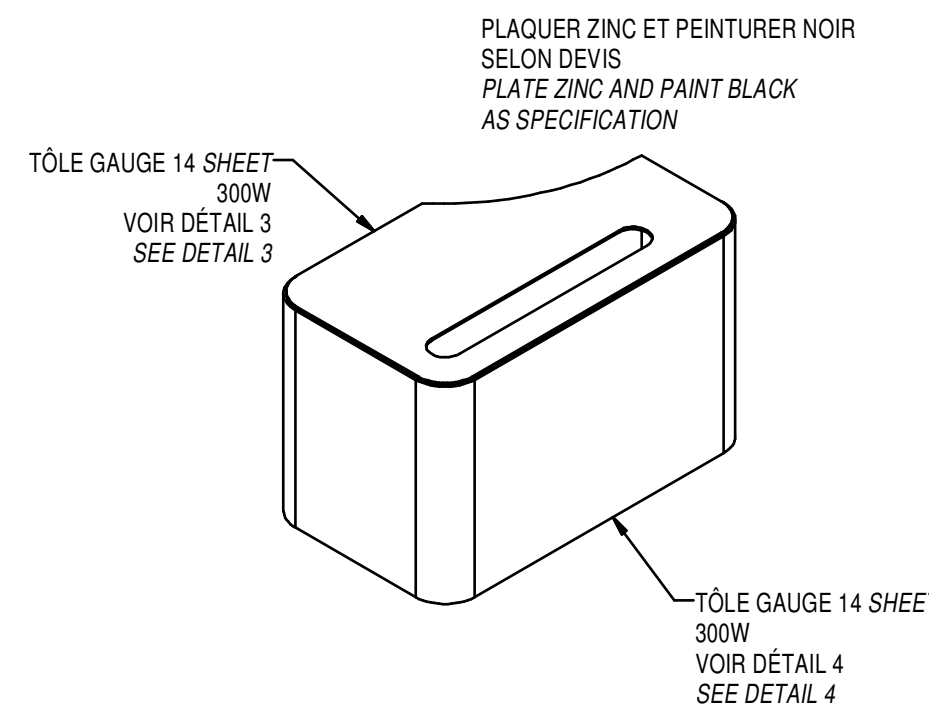

ÉLEVATION - ELEVATION

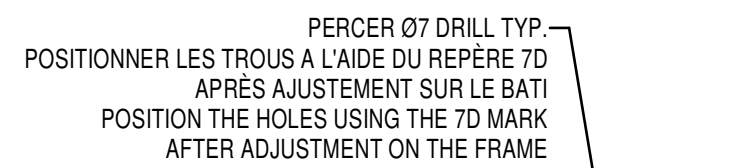

PROFIL - PROFILE

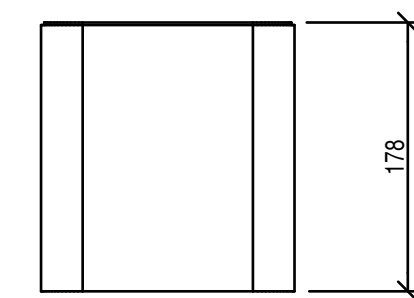

ÉLEVATION - ELEVATION

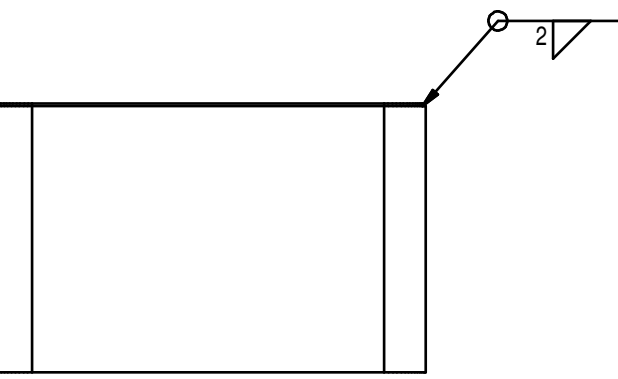

PROFIL - PROFILE

PROTECTEUR DU FREIN
BRAKE PROTECTOR

ÉCH. - SCALE 1: 5

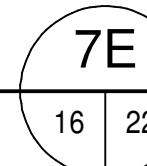

CÔTÉ DROIT : TEL QUEL
CÔTÉ GAUCHE : OPPOSÉ
RIGHT SIDE : AS SHOWN
LEFT SIDE : OPPOSITE

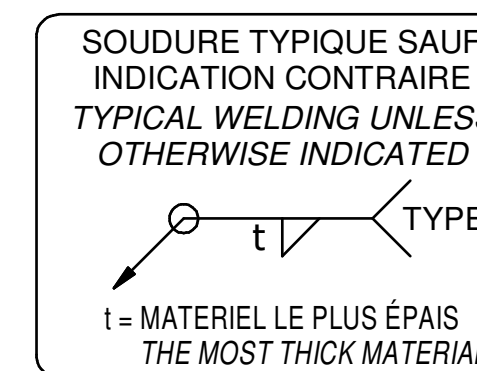

TOLÉRANCES GÉNÉRALES SI NON INDIQUÉES GENERAL TOLERANCES IF NOT INDICATED	
ASSEMBLAGE ~ ASSEMBLY	USINAGE ~ MACHINING
0 A - TO 25 ± 1	0.0 ± 1.0
25 A - TO 600 ± 1.5	0.00 ± 0.5
600 + ± 3	0.000 ... ± 0.1
ANGLE ± 1°	√ 3.2

CE DOCUMENT NE DOIT PAS ÊTRE UTILISÉ À DES FINS DE CONSTRUCTION

THIS DOCUMENT MUST NOT BE USED FOR CONSTRUCTION

01	ÉMIS POUR SOUMISSION ISSUED FOR SUBMISSION	2019-08-07
00	ÉMIS POUR SOUMISSION ISSUED FOR SUBMISSION	2019-07-23
révisions revisions		date

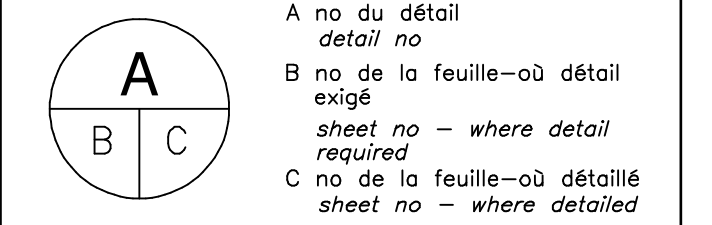

PARCS CANADA
PARKS CANADA
RÉFECTION DE L'ÉCLUSE N°9
DU CANAL-DE-CHAMBLY
REPAIR OF LOCK #9
CHAMBLY CANAL

MÉCANIQUE
MECHANICAL
DÉTAILS
MÉCANISME OUVERTURE DE PORTE
DETAIL
DOOR OPENING MECHANISM

Conçu par Frédéric Dumont, ing.	Designed by 2019-05-21 Date
Dessiné par Jacques Ouellet, techn.	Drawn by 2019-05-21 Date
Approuvé par Jean-René Tremblay, ing.	Approved by 2019-05-21 Date
Soumission Nadia Rusztyn, ing. jr Administrateur de projets APC	Tender 2019 PCA Project Manager
No de projet CCHM-1446	No de contrat Contract number
APC	PCA
Nom du fichier RUC-20-212-MC.22.DWG	No de classement File no
No de plan ou dessin RUC-20-212-MC.22	No feuille Drawing no 22/22