

LISTE DE MATÉRIEL - BILL OF MATERIAL						
ARTICLE	REPERE MARK	QTE QTY	DESCRIPTION	MATÉRIEL - MATERIAL	LONGUEUR LENGTH	FOURNI - PROVIDED REMARQUE - NOTE
9		1	APPUI DE LA CRÉMAILLÈRE - RACK SUPPORT			ENTREPRENEUR CONTRACTOR RUC-20-212-MC.15
9A	2	1	PLAQUE DE SUPPORT - SUPPORT PLATE	ACIER SOUDÉ - WELDED STEEL		RUC-20-212-MC.19
9B	2	1	ROULEAU DE GUIDAGE - GUIDING ROLLER	ACIER C-1045 STEEL		RUC-20-212-MC.19
9C	2	1	ARBRE POUR ROULEAU - ROLLER SHAFT	ACIER INOX. 316 STAINLESS STEEL		RUC-20-212-MC.19
9D	4	1	COUSSINET - BUSHING	BRONZE 660 BRASS		RUC-20-212-MC.19
9E	2	1	COUSSINET - BUSHING	BRONZE 660 BRASS		RUC-20-212-MC.19
9F	2	1	GRAISSEUR DROIT - GREASE FITTING CAT No. 1095K650			MCMaster CARR
9G	4	1	ÉCROU HEXAGONAL 1-8UNC HEXAGONAL NUT	ACIER INOX. 18-8 STAINLESS STEEL		
9H	4	1	RONDELLE PLATE Ø1" FLAT WASHER	ACIER INOX. 18-8 STAINLESS STEEL		

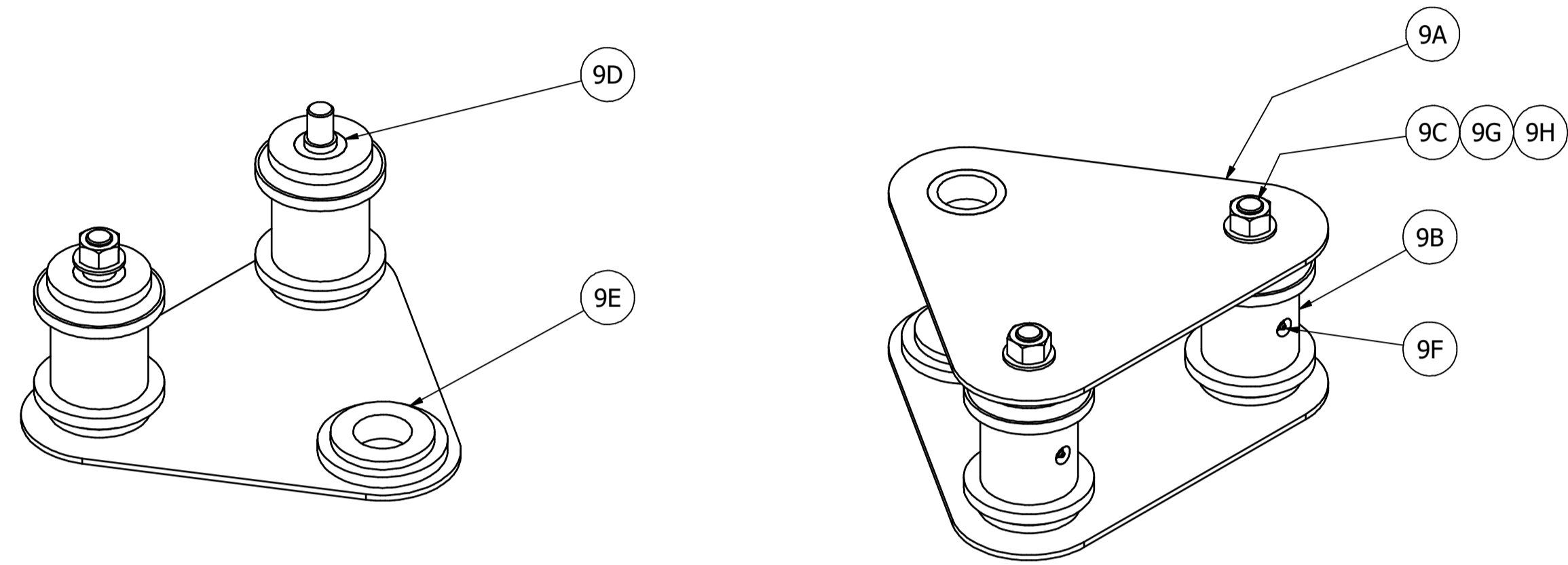

SANS PLAQUE SUPÉRIEURE
WITHOUT TOP PLATE

APPUI DE LA CRÉMAILLÈRE **9** VUE ISOMÉTRIQUE
RACK SUPPORT **15 17** ISOMETRIC VIEW
N.À.É. ~ N.T.S.

LISTE DE MATÉRIEL - BILL OF MATERIAL						
ARTICLE	REPERE	QTE	DESCRIPTION	MATÉRIEL	LONGUEUR	FOURNI REMARQUE
11		1	ROULEAU DE GUIDAGE - GUIDING ROLLER			ENTREPRENEUR CONTRACTOR RUC-20-212-MC.15
11A	1	1	ROULEAU DE SUPPORT - SUPPORT ROLLER	ACIER C-1045 STEEL		RUC-20-212-MC.19
11B	1	1	ARBRE DE ROULEAU - ROLLER SHAFT	ACIER INOX. 316 STAINLESS STEEL		RUC-20-212-MC.19
9E	2	1	COUSSINET - BUSHING	BRONZE 660 BRASS		RUC-20-212-MC.19
11C	1	1	GRAISSEUR DROIT - GREASE FITTING CAT No. 1095K650			MCMaster CARR
11D	2	1	TIGE FILETÉE 3/4-10UNC THREADED ROD	ACIER INOX. 18-8 STAINLESS STEEL		
11E	4	1	ÉCROU HEXAGONAL 3/4-10UNC HEXAGONAL NUT	ACIER INOX. 18-8 STAINLESS STEEL		
11F	4	1	RONDELLE PLATE Ø3/4" FLAT WASHER	ACIER INOX. 18-8 STAINLESS STEEL		

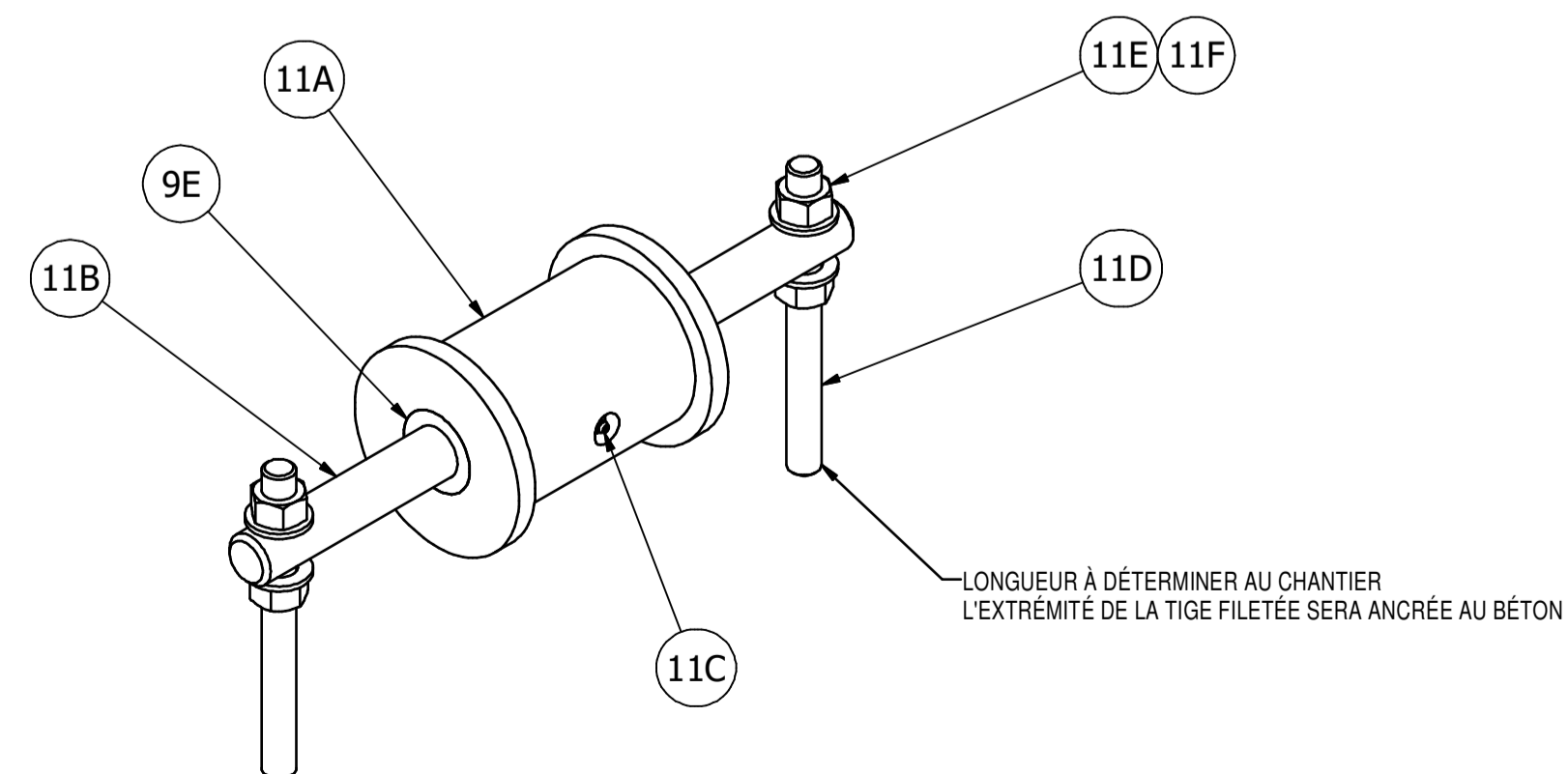

ROULEAU DE GUIDAGE **11** VUE ISOMÉTRIQUE
GUIDING ROLLER **15 17** ISOMETRIC VIEW
N.À.É. ~ N.T.S.

LISTE DE MATÉRIEL - BILL OF MATERIAL						
ARTICLE	REPERE MARK	QTE QTY	DESCRIPTION	MATÉRIEL - MATERIAL	LONGUEUR LENGTH	FOURNI - PROVIDED REMARQUE - NOTE
10		1	ASSEMBLAGE DE LA CRÉMAILLÈRE - RACK ASSEMBLY			ENTREPRENEUR CONTRACTOR RUC-20-212-MC.15
10A	1	1	ATTACHE DE LA PORTE - DOOR ATTACH	ACIER SOUDÉ - WELDED STEEL		RUC-20-212-MC.21
10B	1	1	POUTRE EN I - I BEAM	ACIER 350W STEEL		RUC-20-212-MC.21
10C	4	1	CRÉMAILLÈRE - RACK	FONTE GRISE ASTM A48 CLASSE 40 CAST IRON		RUC-20-212-MC.21
10D	4	1	VIS À TÊTE HEXAGONALE 5/8-11UNC HEXAGONAL BOLT	ACIER INOX. 18-8 STAINLESS STEEL		
10E	12	1	VIS À TÊTE CYLINDRIQUE 1/2-13UNC SOCKET HEAD SCREW	ACIER INOX. 18-8 STAINLESS STEEL	2"	
10F	12	1	ÉCROU HEXAGONAL 1/2-13UNC HEXAGONAL NUT	ACIER INOX. 18-8 STAINLESS STEEL	2 1/4"	
10G	4	1	ÉCROU HEXAGONAL 5/8-11UNC HEXAGONAL NUT	ACIER INOX. 18-8 STAINLESS STEEL		
10H	12	1	RONDELLE PLATE Ø1/2" FLAT WASHER	ACIER INOX. 18-8 STAINLESS STEEL		
10J	8	1	RONDELLE PLATE Ø5/8" FLAT WASHER	ACIER INOX. 18-8 STAINLESS STEEL		

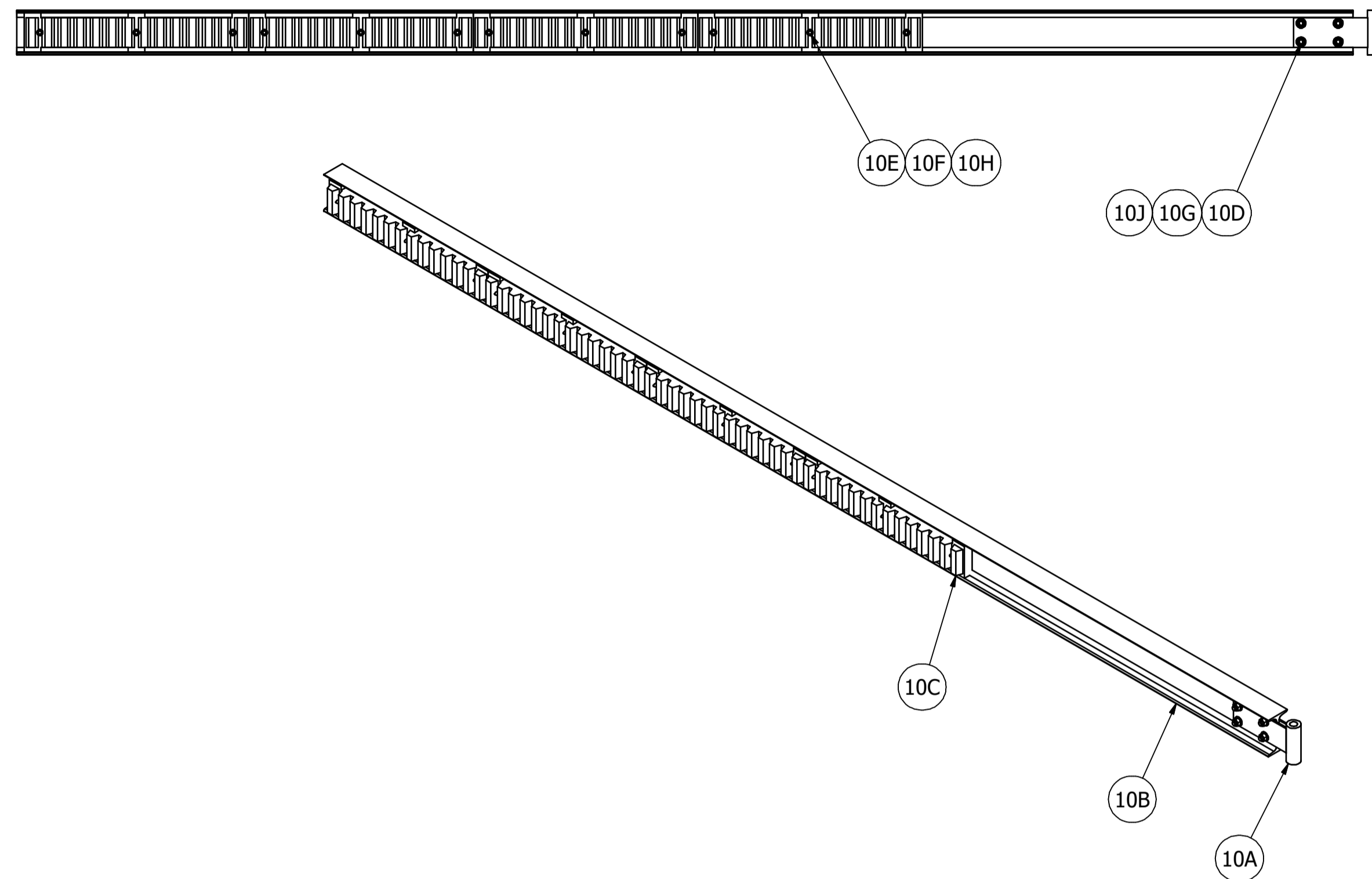

ASSEMBLAGE DE LA CRÉMAILLÈRE **10** VUE ISOMÉTRIQUE
RACK ASSEMBLY **15 17** ISOMETRIC VIEW
N.À.É. ~ N.T.S.

N/D: 159000119
Stantec Experts-conseils Inc.
1200, boul. Saint-Martin Ouest, bureau 300
Laval (Québec) H7V 2E4

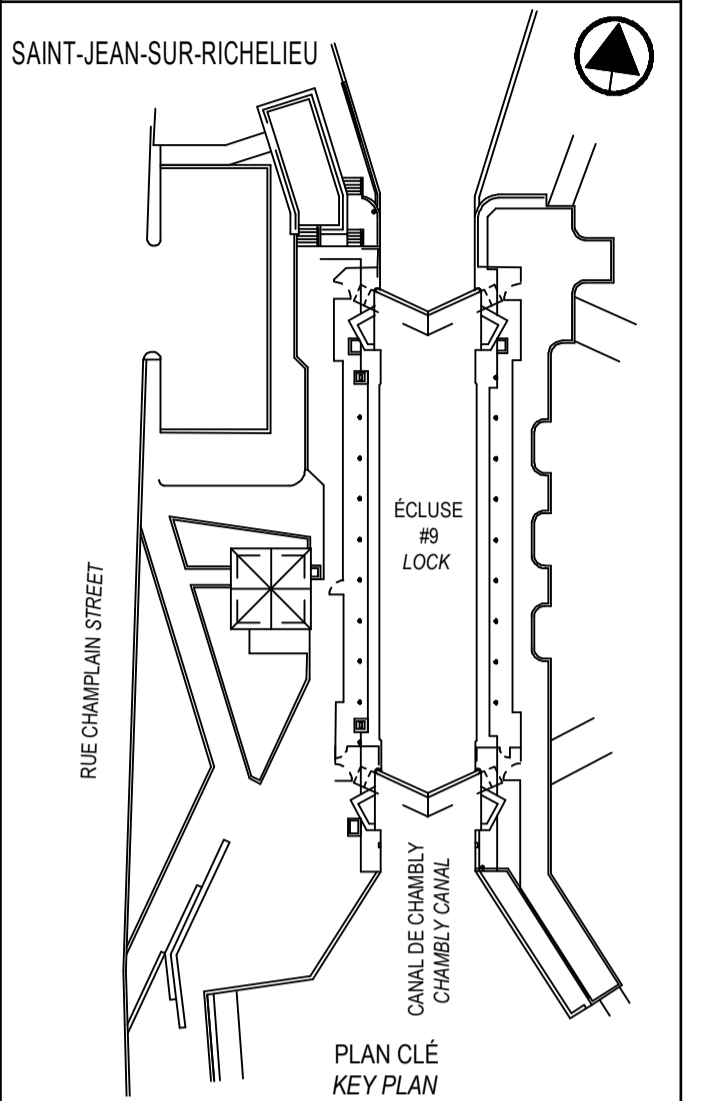

SCEAUX SEALS

01	EMIS POUR SOUMISSION ISSUED FOR SUBMISSION	2019-08-07
00	EMIS POUR SOUMISSION ISSUED FOR SUBMISSION	2019-07-23
révisions revisions		date

A	A no du détail detail no
B	B no de la feuille-où détail sheet no - where detail required
C	C no de la feuille-où détaillé sheet no - where detailed

Projet Project

PARCS CANADA
PARKS CANADA
RÉFECTION DE L'ÉCLUSE N°9
DU CANAL-DE-CHAMBLÉ
REPAIR OF LOCK #9
CHAMBLÉ CANAL

Dessin Drawing

MÉCANIQUE
MECHANICAL
DÉTAILS
MÉCANISME OUVERTURE DE PORTE
DETAIL
DOOR OPENING MECHANISM

Conçu par Designed by
Frédéric Dumont, ing. 2019-05-21
Date

Dessiné par Drawn by
Jacques Ouellet, techn. 2019-05-21
Date

Approuvé par Approved by
Jean-René Tremblay, ing. 2019-05-21
Date

Soumission Tender
Nadia Rusztyn, ing. jr 2019
Administrateur de projets APC PCA Project Manager

No de projet Project number No de contrat Contract number
CCHM-1446

Nom du fichier File name No de classement
RUC-20-212-MC.17.DWG

No de plan ou dessin File name No feuille Drawing no
RUC-20-212-MC.17 17/22

CE DOCUMENT NE DOIT PAS
ÊTRE UTILISÉ À DES FINS DE
CONSTRUCTION

THIS DOCUMENT MUST NOT BE
USED FOR CONSTRUCTION