

ÉLÉVATION - ELEVATION

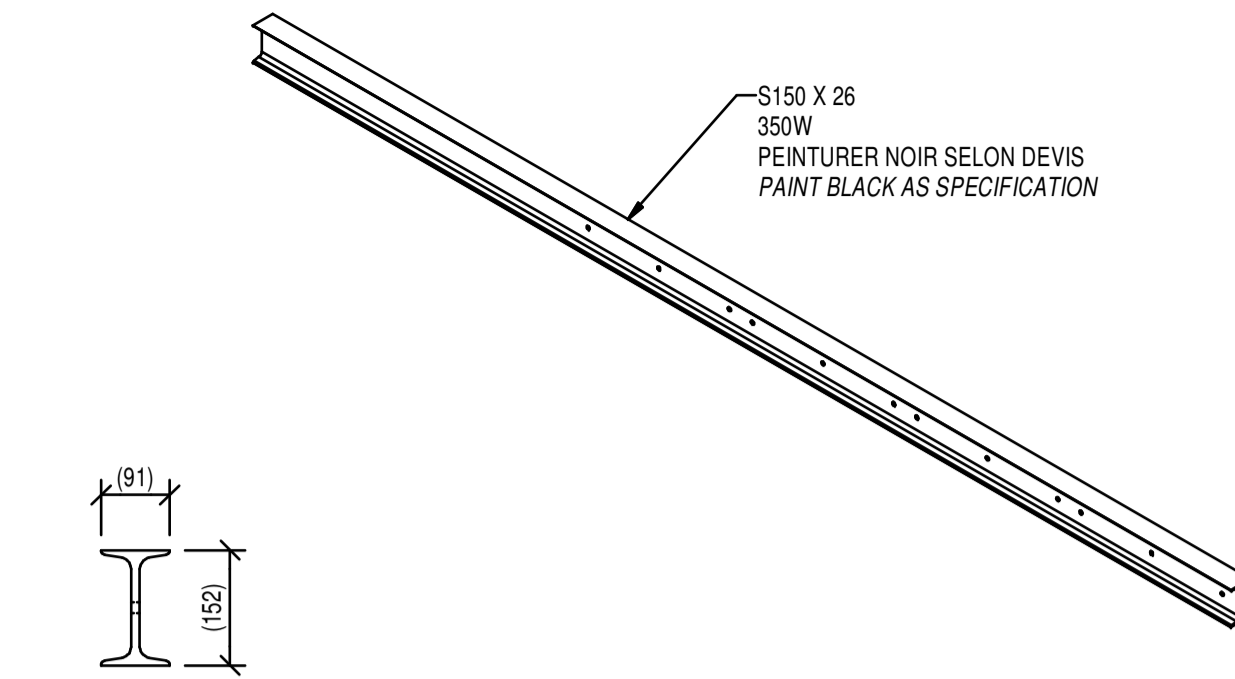

PROFIL - PROFILE

POUTRE **10B**
BEAM 17 21
ÉCH. - SCALE 1: 10

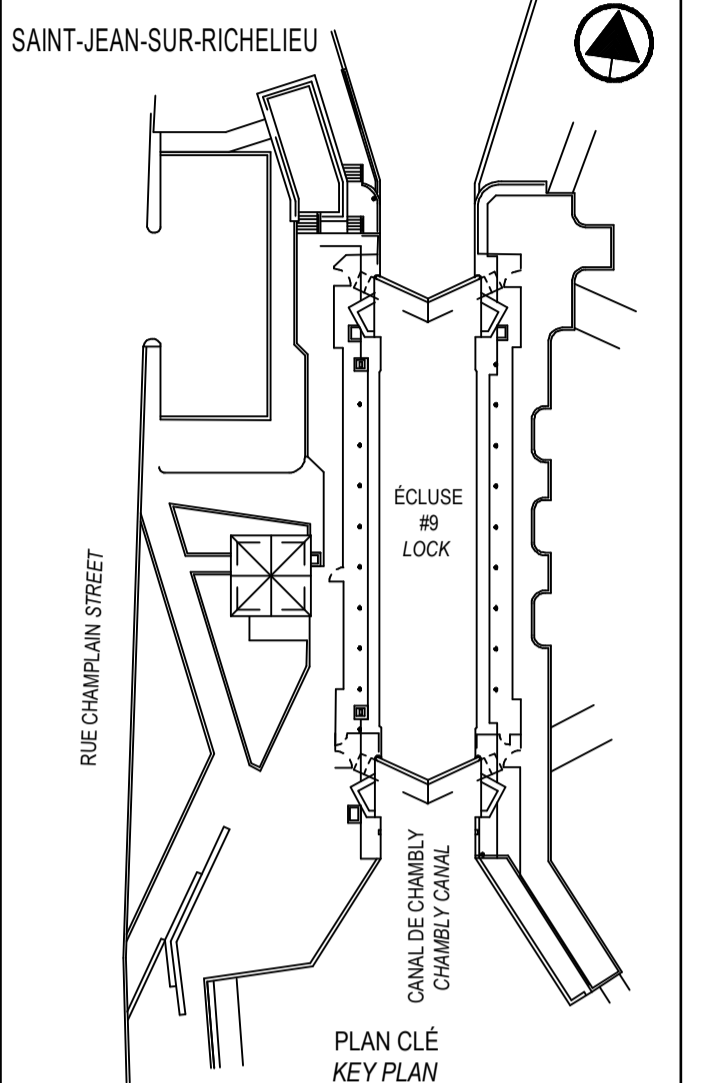

SCEAUX SEALS

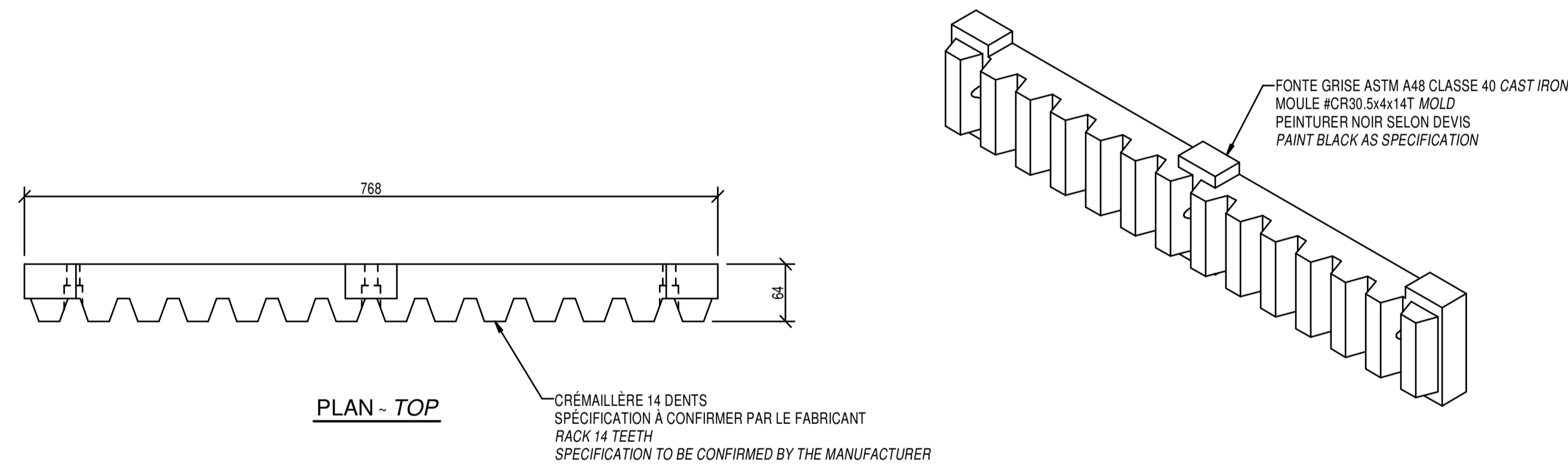

PLAN - TOP

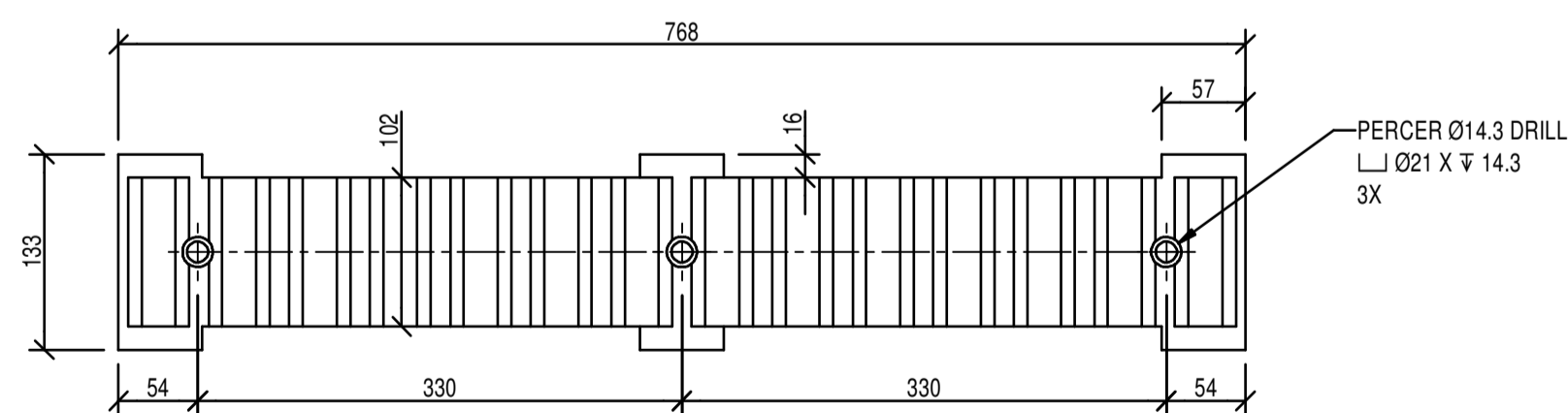

ÉLÉVATION - ELEVATION

CRÉMAILLÈRE **10C**
RACK 17 21
ÉCH. - SCALE 1: 5

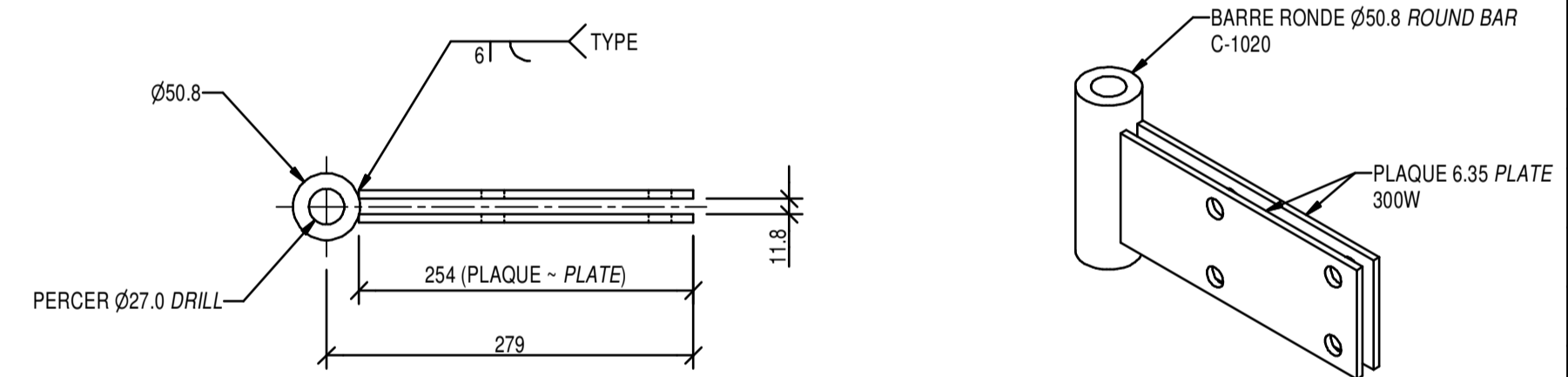

PLAN - TOP

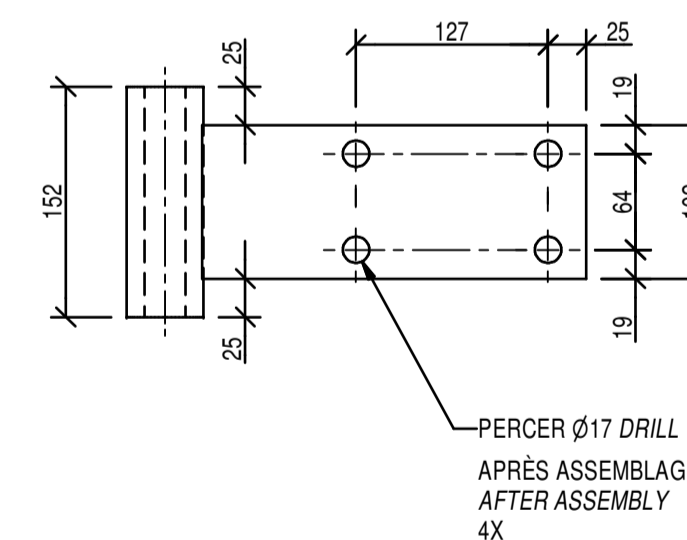

ÉLÉVATION - ELEVATION

ATTACHE DE LA PORTE **10A**
DOOR ATTACH 17 21
ÉCH. - SCALE 1: 5

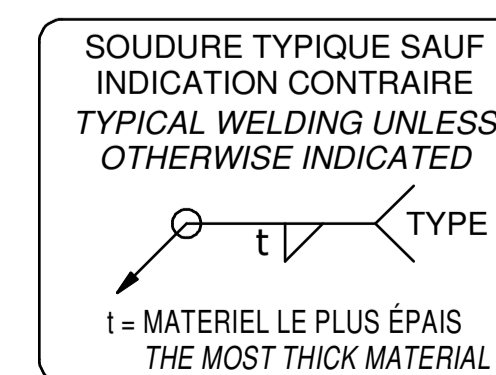

TOLÉRANCES GÉNÉRALES SI NON INDIQUÉES GENERAL TOLERANCES IF NOT INDICATED	
ASSEMBLAGE ~ ASSEMBLY	USINAGE ~ MACHINING
0 A - TO 25 ± 1	0.0 ± 1.0
25 A - TO 600 ± 1.5	0.00 ± 0.5
600 + ± 3	0.000 ... ± 0.1
ANGLE ± 1°	✓ 3.2

CE DOCUMENT NE DOIT PAS ÊTRE UTILISÉ À DES FINS DE CONSTRUCTION

THIS DOCUMENT MUST NOT BE USED FOR CONSTRUCTION

révisions / revisions	date
01	ÉMIS POUR SOUMISSION ISSUED FOR SUBMISSION 2019-08-07
00	ÉMIS POUR SOUMISSION ISSUED FOR SUBMISSION 2019-07-23

A	A no du détail / detail no
B	B no de la feuille-où détail exigé / sheet no - where detail required
C	C no de la feuille-où détaillé / sheet no - where detailed

Projet / Project
PARCS CANADA
PARKS CANADA
RÉFECTION DE L'ÉCLUSE N°9
DU CANAL-DE-CHAMBLY
REPAIR OF LOCK #9
CHAMBLY CANAL

Dessin / Drawing
MÉCANIQUE
MECHANICAL
DÉTAILS
MÉCANISME OUVERTURE DE PORTE
DETAIL
DOOR OPENING MECHANISM

Conçu par / Designed by
Frédéric Dumont, ing. 2019-05-21
Date

Dessiné par / Drawn by
Jacques Ouellet, techn. 2019-05-21
Date

Approuvé par / Approved by
Jean-René Tremblay, ing. 2019-05-21
Date

Soumission / Tender
Nadia Rusztyń, ing. jr 2019
Administrateur de projets APC PCA Project Manager

No de projet / Project number
CCHM-1446 No de contrat / Contract number

Nom du fichier / File name
RUC-20-212-MC.21.DWG No de classement

No de plan ou dessin / File name
RUC-20-212-MC.21 No feuille / Drawing no
21/22