

ÉLÉVATION - ELEVATION

PROFIL - PROFILE

ENGRENAGE À 6 DENTS
GEAR 6 TEETH
ÉCH. - SCALE 1: 2.5

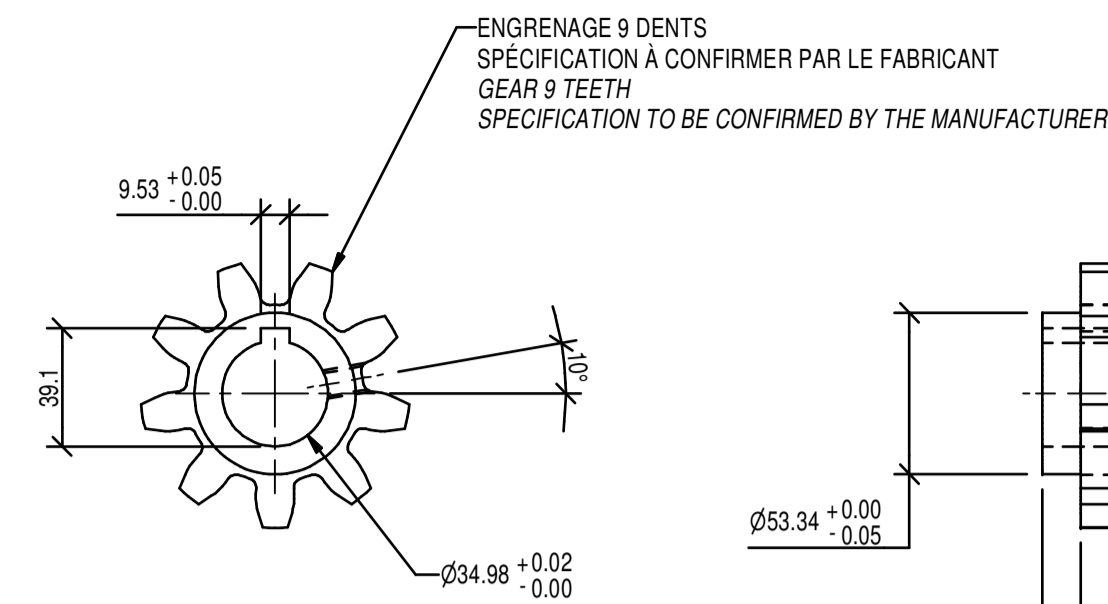
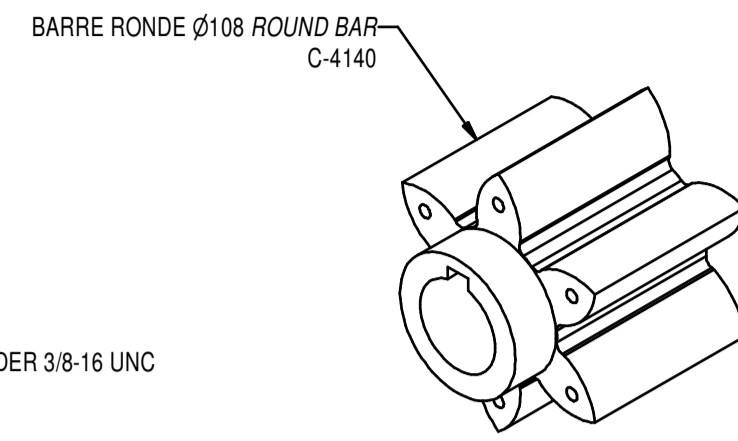

ÉLÉVATION - ELEVATION

PROFIL - PROFILE

ENGRENAGE À 9 DENTS
GEAR 9 TEETH
ÉCH. - SCALE 1: 2.5

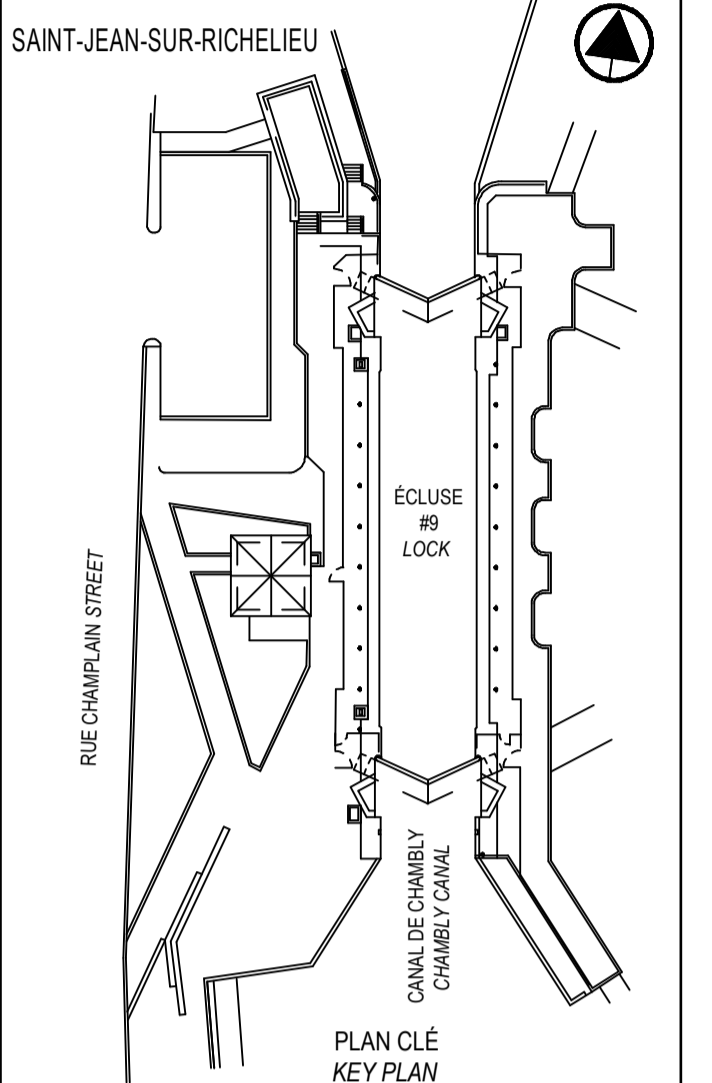
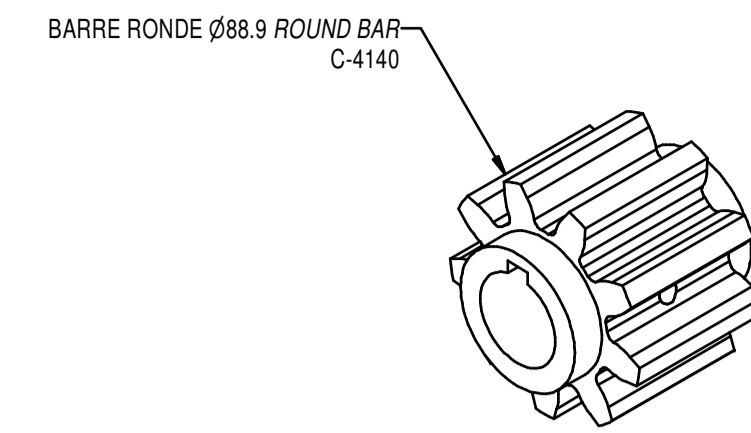

SCEAUX SEALS



01	ÉMIS POUR SOUMISSION ISSUED FOR SUBMISSION	2019-08-07
00	ÉMIS POUR SOUMISSION ISSUED FOR SUBMISSION	2019-07-23

révisions revisions	date
------------------------	------

Projet Project

PARCS CANADA
PARKS CANADA
RÉFÉCTION DE L'ÉCLUSE N°9
DU CANAL - DE - CHAMBLY
REPAIR OF LOCK #9
CHAMBLAY CANAL

Dessin Drawing

MÉCANIQUE
MECHANICAL

DÉTAILS
MÉCANISME OUVERTURE DES VANNES
DETAIL
GATE OPENING MECHANISM

Conçu par Designed by
Frédéric Dumont, ing. 2019-05-21
Date

Dessiné par Drawn by
Jacques Ouellet, techn. 2019-05-21
Date

Approuvé par Approved by
Jean-René Tremblay, ing. 2019-05-21
Date

Soumission Tender
Nadia Rusztyn, ing. jr 2019
Administrateur de projets APC PCA Project Manager

No de projet Project number No de contrat Contract number
CCHM-1446

Nom du fichier File name No de classement
RUC-20-212-MC.09.DWG

No de plan ou dessin File name No feuille Drawing no
RUC-20-212-MC.09 09/22

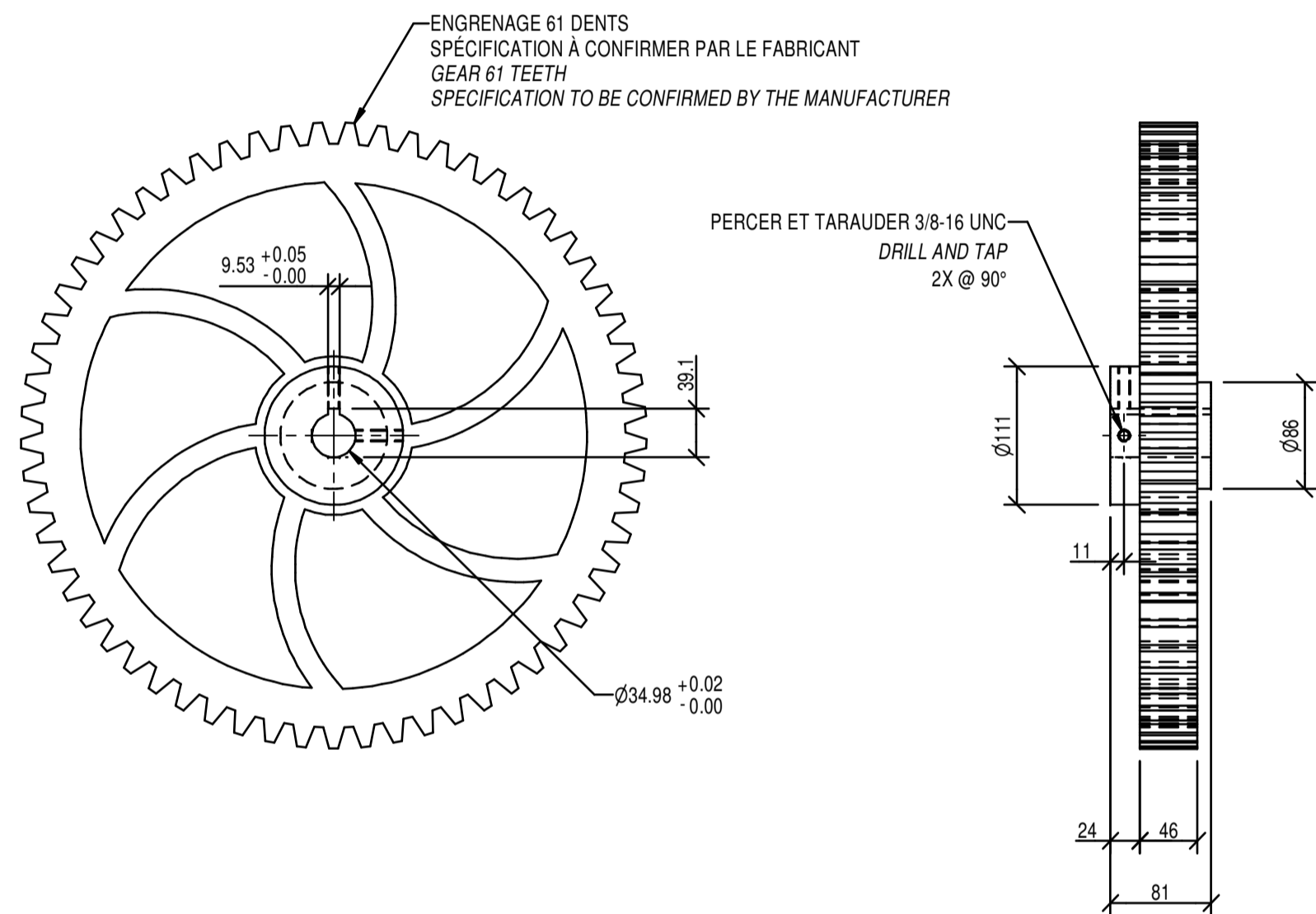

ÉLÉVATION - ELEVATION

PROFIL - PROFILE

ENGRENAGE À 61 DENTS
GEAR 61 TEETH
ÉCH. - SCALE 1: 5

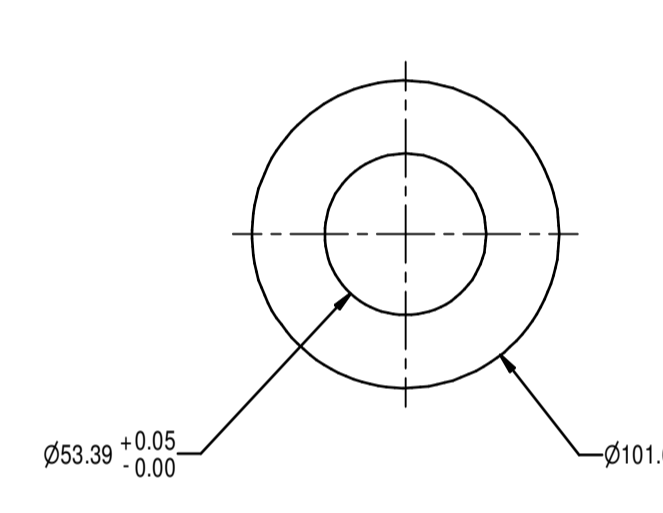
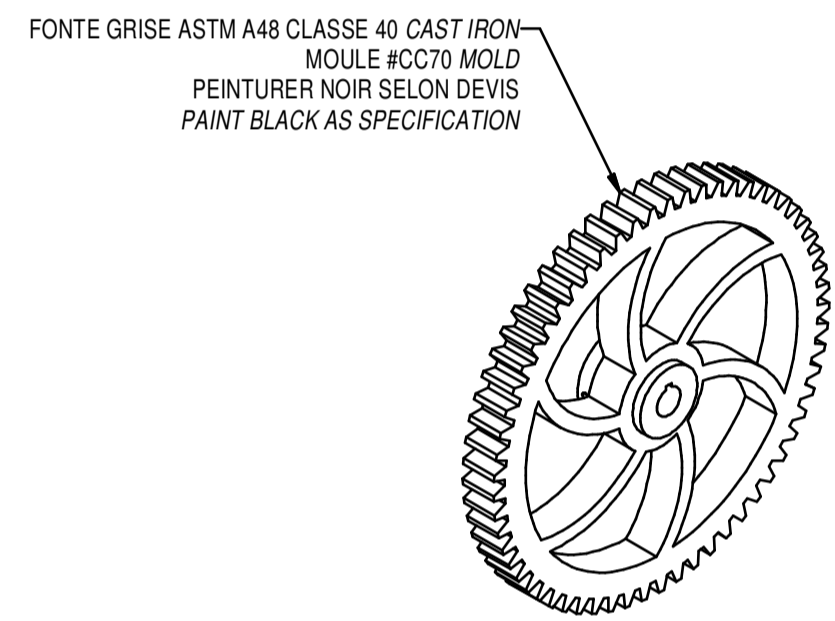

ÉLÉVATION - ELEVATION

PROFIL - PROFILE

RONDELLE DE GUIDAGE
GUIDING WASHER
ÉCH. - SCALE 1: 2.5

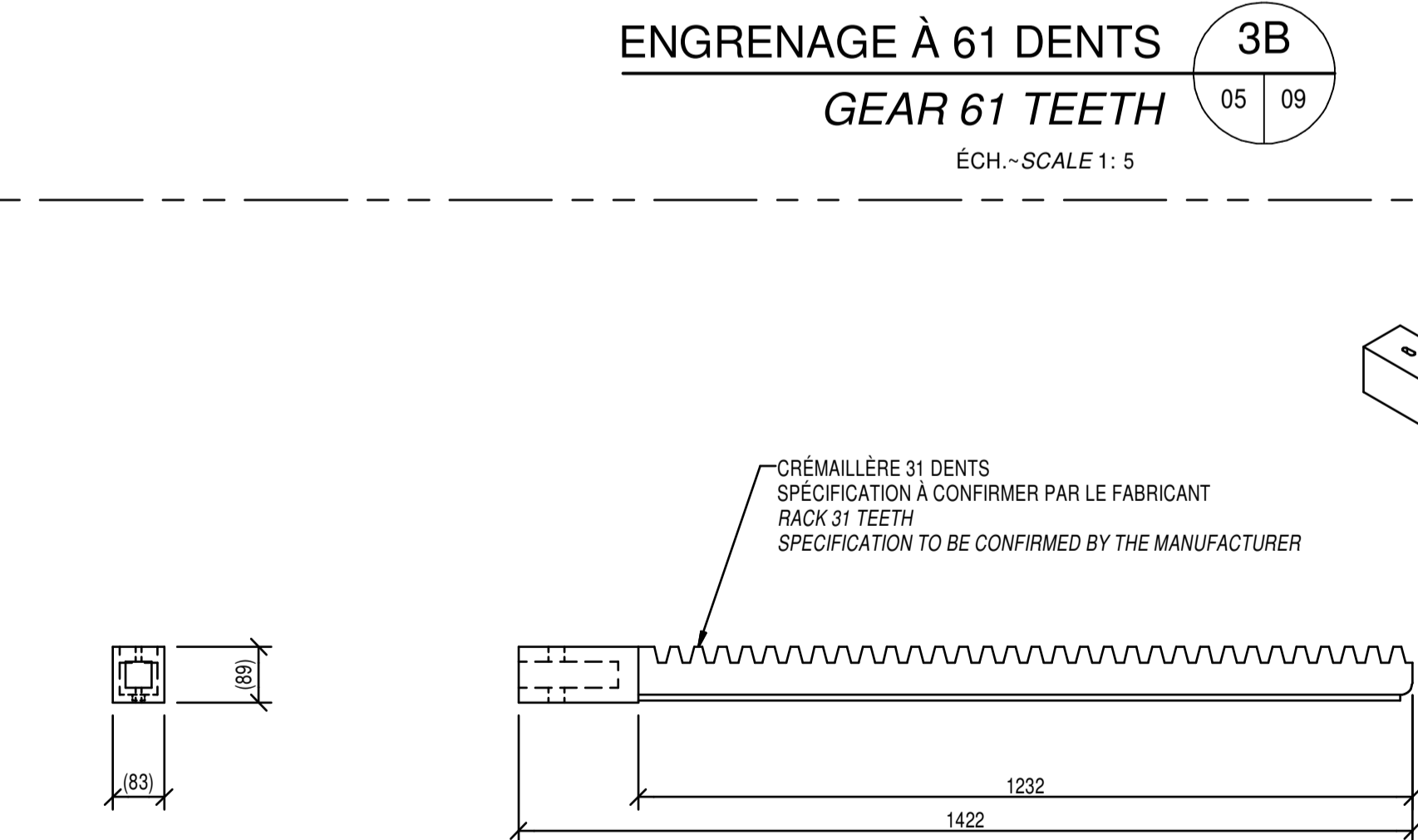
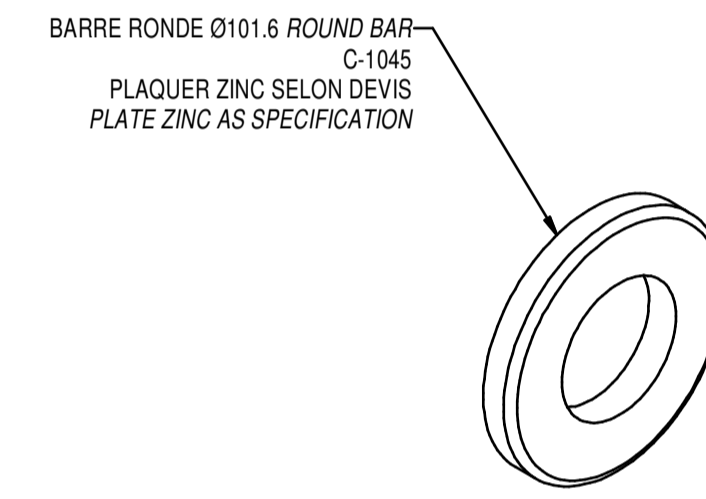

PROFIL - PROFILE

ÉLÉVATION - ELEVATION

CRÉMAILLÈRE
RACK
ÉCH. - SCALE 1: 10

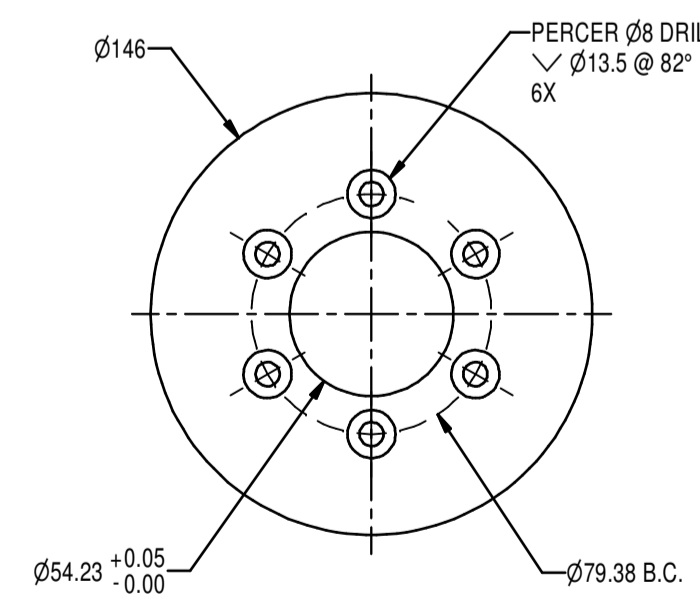
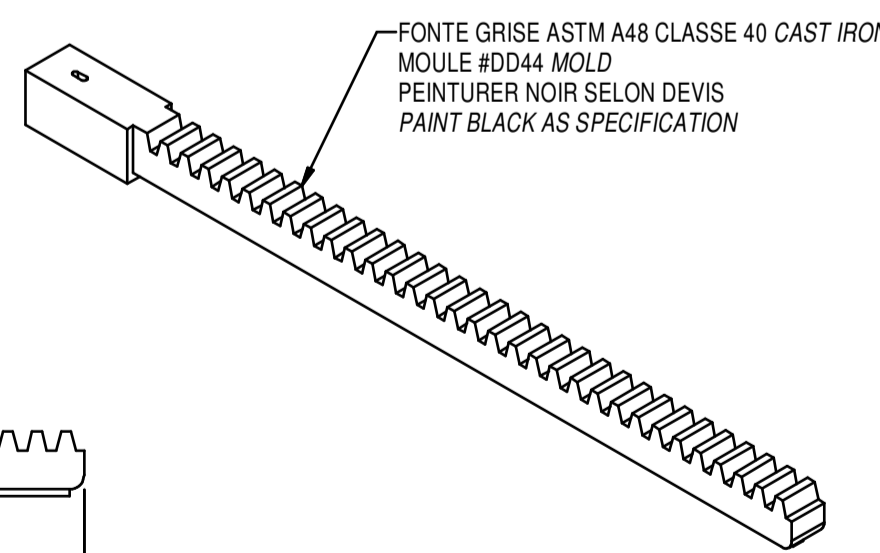

ÉLÉVATION - ELEVATION

PROFIL - PROFILE

RONDELLE DE GUIDAGE
GUIDING WASHER
ÉCH. - SCALE 1: 2.5

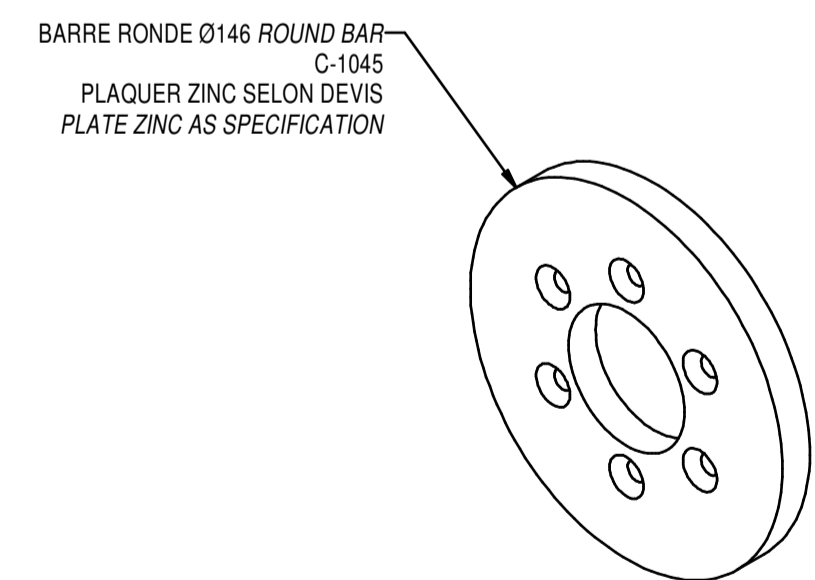

TOLÉRANCES GÉNÉRALES SI NON INDIQUÉES GENERAL TOLERANCES IF NOT INDICATED	
ASSEMBLAGE ~ ASSEMBLY	USINAGE ~ MACHINING
0 A - TO 25 ± 1	0.0 ± 1.0
25 A - TO 600 ± 1.5	0.00 ± 0.5
600 + ± 3	0.000 ... ± 0.1
ANGLE ± 1°	√ ... 3.2

CE DOCUMENT NE DOIT PAS
ÊTRE UTILISÉ À DES FINS DE
CONSTRUCTION

THIS DOCUMENT MUST NOT BE
USED FOR CONSTRUCTION