

**ARBRE D'ENTRAINEMENT** 8A  
**SHAFT** 16 20  
ÉCH.-SCALE 1: 5

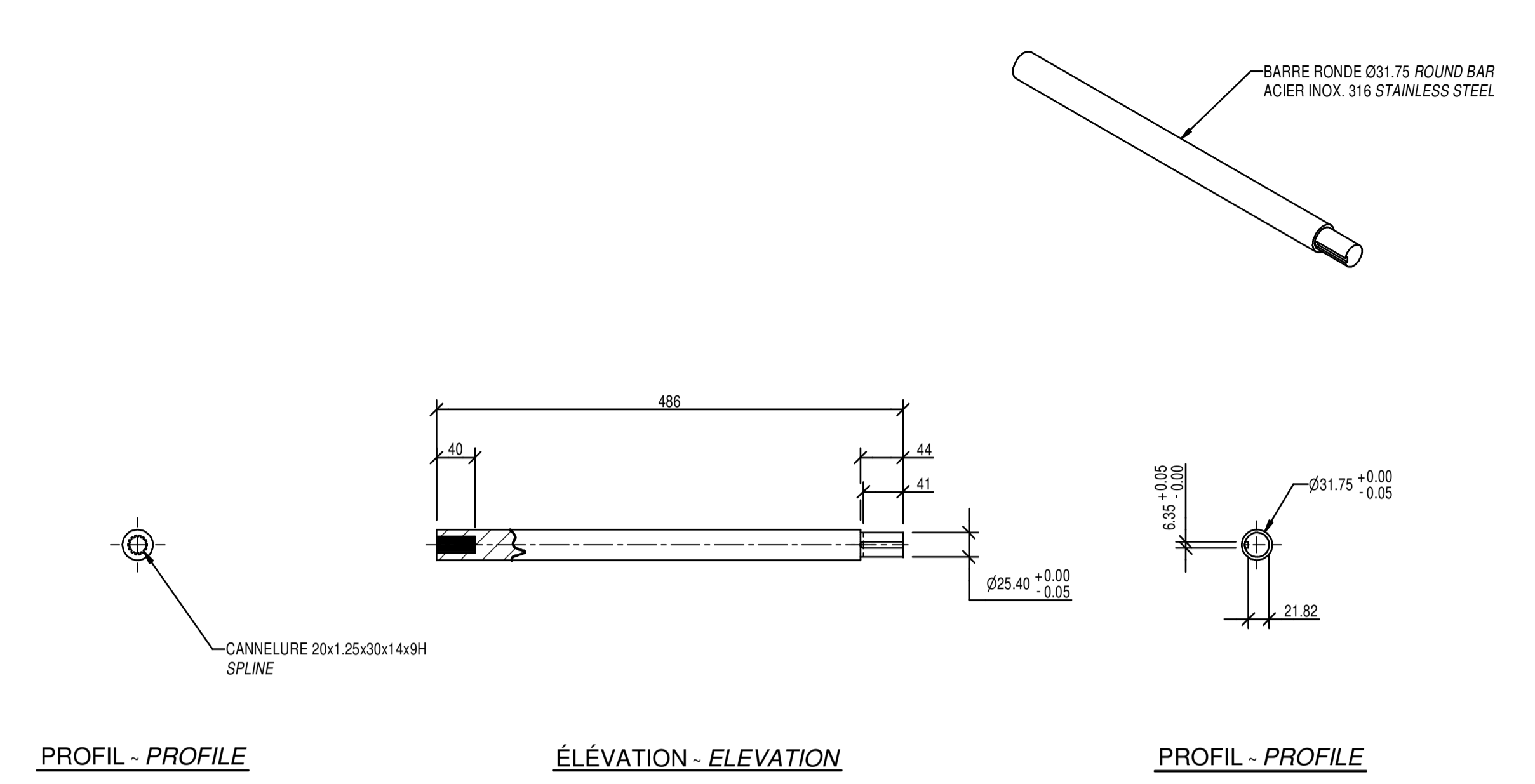

**ARBRE DE MANIVELLE** 8E  
**CRANK SHAFT** 16 20  
ÉCH.-SCALE 1: 5

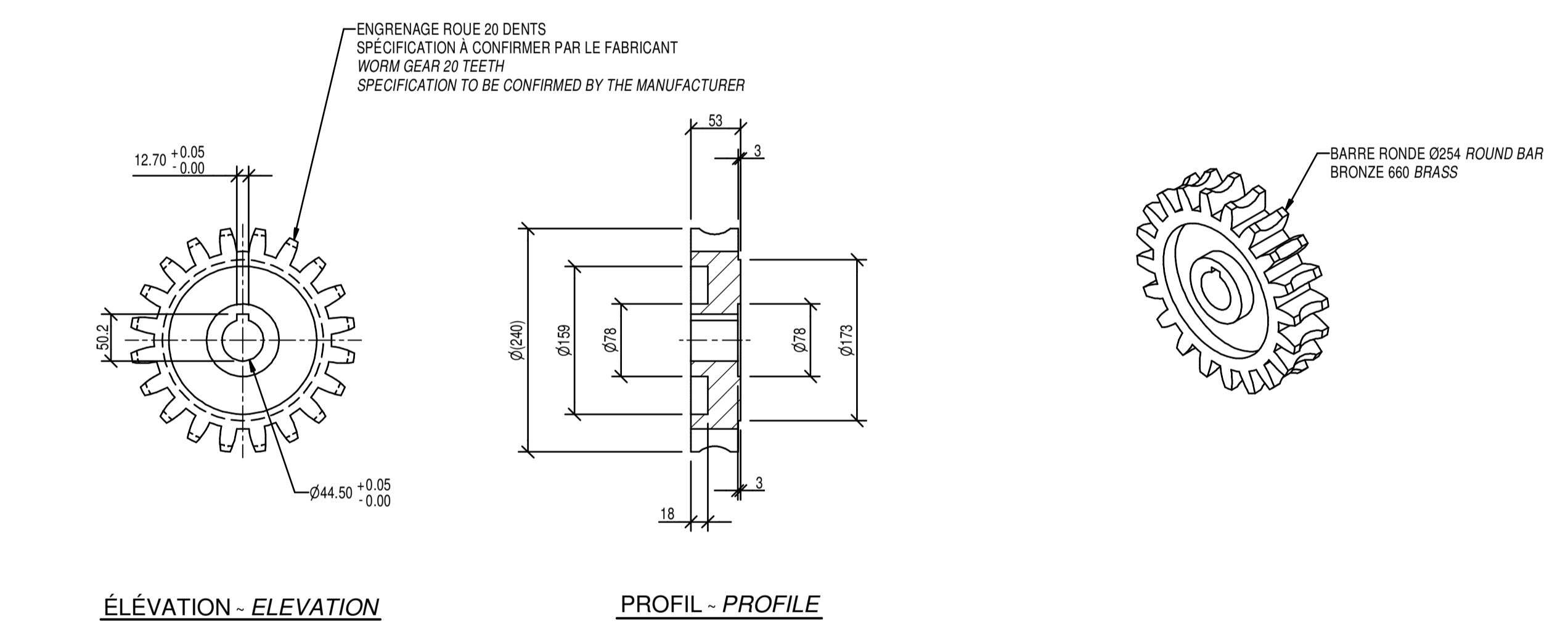
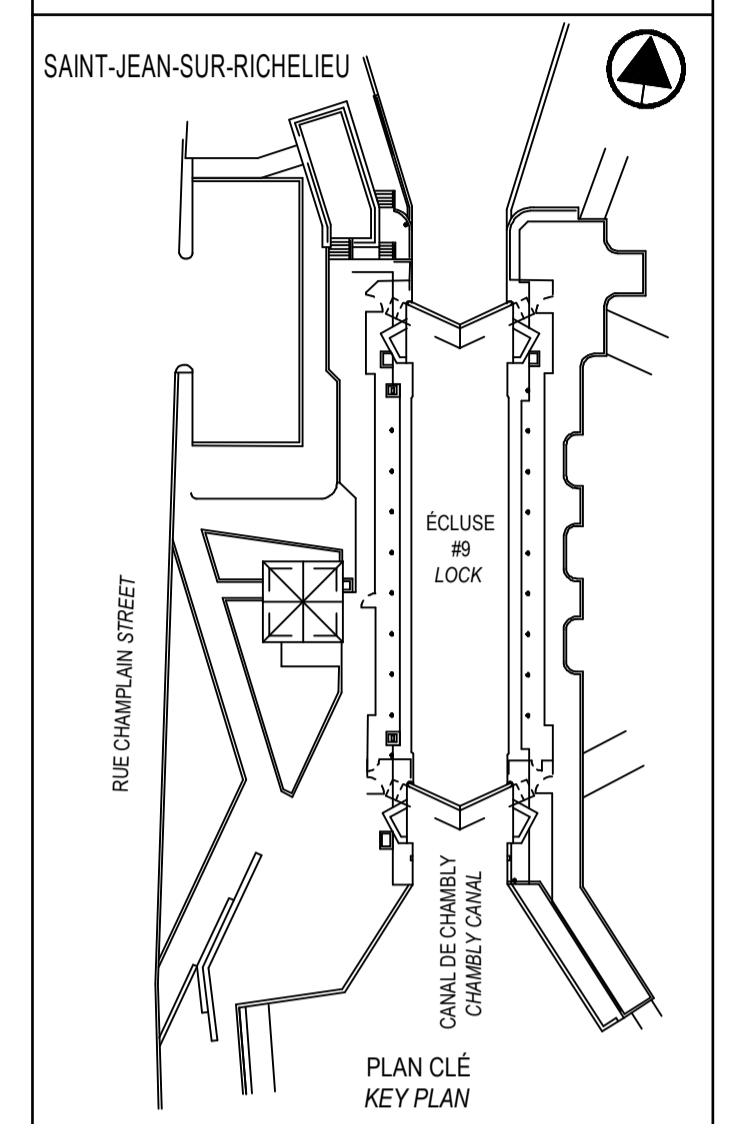

**ENGRENAGE ROUE** 8C  
**WORM GEAR** 16 20  
ÉCH.-SCALE 1: 5

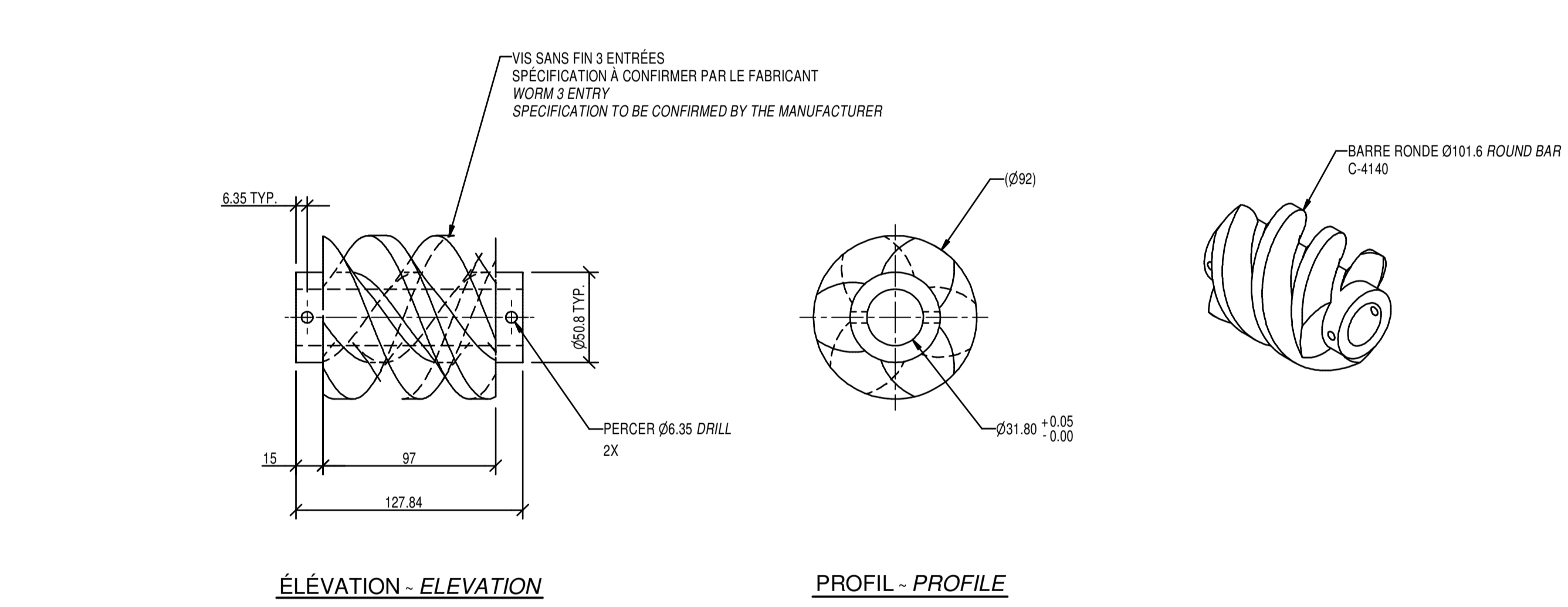

**VIS SANS FIN** 8D  
**WORM** 16 20  
ÉCH.-SCALE 1: 2.5

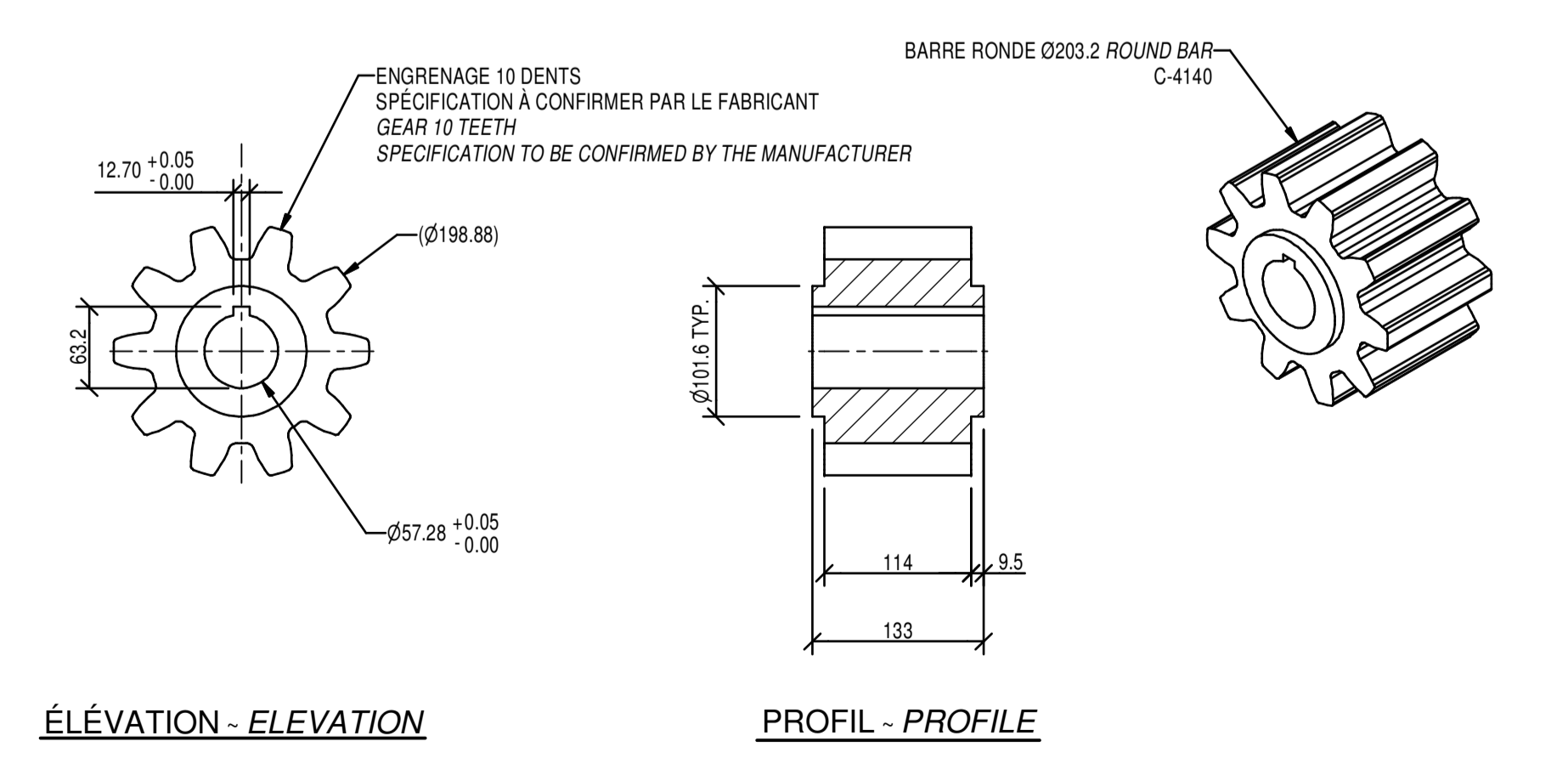

**ENGRENAGE 10 DENTS** 8B  
**GEAR 10 TEETH** 16 20  
ÉCH.-SCALE 1: 5

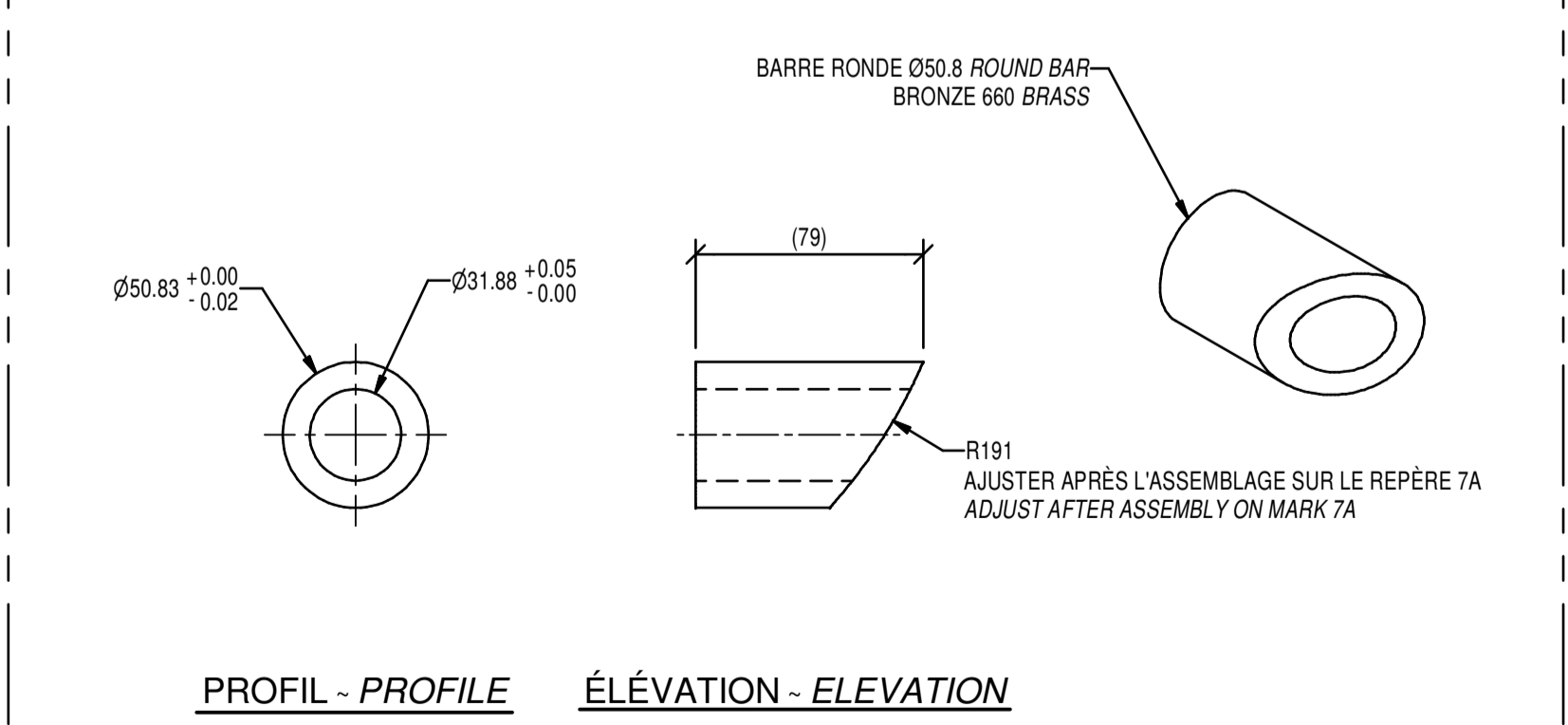

**COUSSINET** 7F  
**BUSHING** 16 20  
ÉCH.-SCALE 1: 2.5

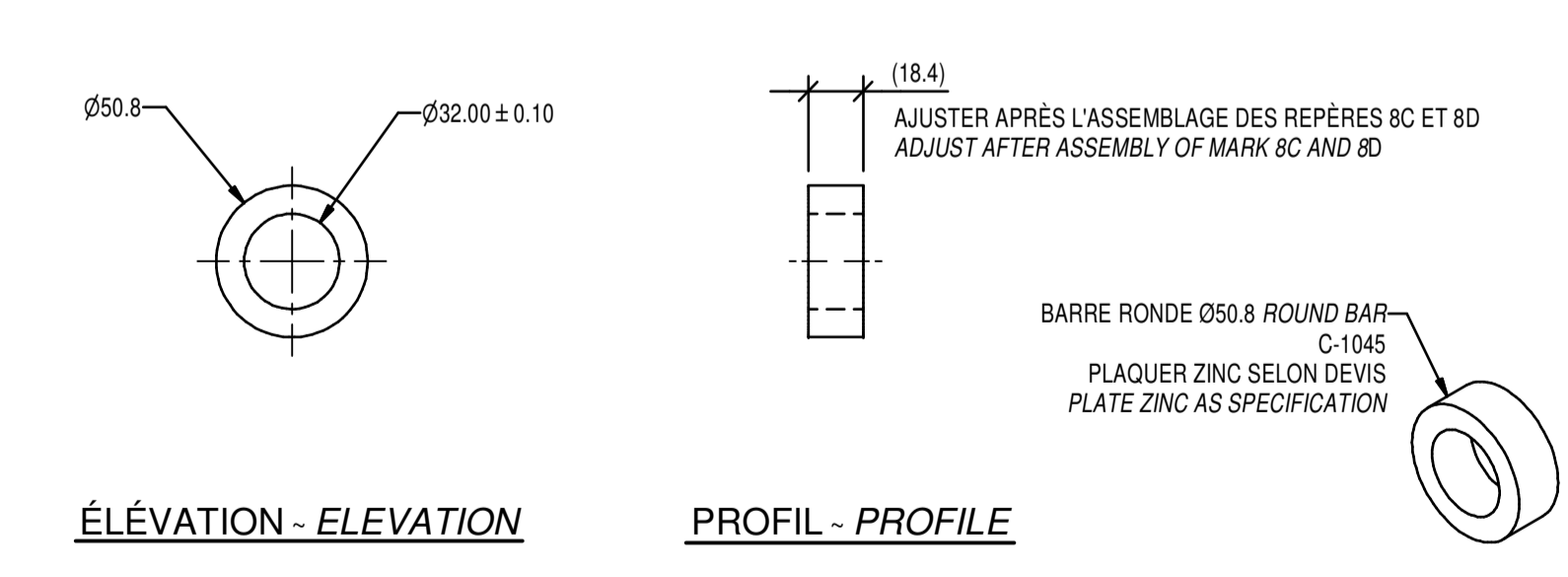

**ESPACEUR** 8G  
**SPACER** 16 20  
ÉCH.-SCALE 1: 2.5

TOLÉRANCES GÉNÉRALES SI NON INDIQUÉES GENERAL TOLERANCES IF NOT INDICATED	
ASSEMBLAGE ~ ASSEMBLY	USINAGE ~ MACHINING
0 A - TO 25 ..... ± 1	0.0 ..... ± 1.0
25 A - TO 600 ..... ± 1.5	0.00 ..... ± 0.5
600 + ..... ± 3	0.000 ... ± 0.1
ANGLE ..... ± 1°	√ ... 3.2

CE DOCUMENT NE DOIT PAS  
ÊTRE UTILISÉ À DES FINS DE  
CONSTRUCTION

THIS DOCUMENT MUST NOT BE  
USED FOR CONSTRUCTION

SCEAUX		
revisions	revisions	date
01	EMIS POUR SOUMISSION ISSUED FOR SUBMISSION	2019-08-07
00	EMIS POUR SOUMISSION ISSUED FOR SUBMISSION	2019-07-23

PARCS CANADA  
PARKS CANADA

RÉFECTION DE L'ÉCLUSE N°9  
DU CANAL-DE-CHAMBLY

REPAIR OF LOCK #9  
CHAMBLÉ CANAL

MÉCANIQUE  
MECHANICAL

DÉTAILS  
MÉCANISME OUVERTURE DE PORTE  
DETAIL  
DOOR OPENING MECHANISM

Conçu par Frédéric Dumont, ing.	Designed by 2019-05-21 Date
Dessiné par Jacques Ouellet, techn.	Drawn by 2019-05-21 Date
Approuvé par Jean-René Tremblay, ing.	Approved by 2019-05-21 Date
Soumission Nadia Rusztyn, ing. jr	Tender 2019 Date
Administrateur de projets APC	PCA Project Manager
No de projet CCHM-1446	No de contrat Contract number
APC	PCA
Nom du fichier RUC-20-212-MC.20.DWG	File name No de classement
No de plan ou dessin RUC-20-212-MC.20	File name No feuillet Drawing no 20/22