

A-5 ARCHITECTURE – DOORS & FRAMES

1. SCOPE

This section identifies the requirements for all doors and frames used in correctional institutions.

2. RELATED SECTIONS

2.1 *Technical Criteria Document sections:*

- A-2 – Architecture – Building Construction
- A-3 – Grilles, Mesh and Screens
- A-4 – Glazing, Windows and Assemblies
- A-6 – Hardware
- A-11 – Inmate Cells
- A-13 – Security Control Posts, Galleries and Routes

2.2 *CSC/PWC Specifications*

- 08 34 63 Detention hollow metal frames, doors, and door frames (11193 before 2004)
- 08 34 63.13 Steel Detention Doors and Frames
- 08 34 63.16 Steel Plate Detention Doors and Frames
- 08 34 63.33 Detention Door Frame Protection
- 08 71 63 Detention Door Hardware (11192 before 2004)
- 11 19 13 Detention Pass-Through Doors

2.3 *Standards*

2.3.1 ANSI/BHMA – American National Standard

- A156.4-2008–Doors Controls – Closers, Oct. 2008
- A156.14-2007–Sliding and Folding Door Hardware, Sept. 2007

2.3.2 NAAMM HMMA – National Association of Architectural Metal Manufacturers

- 801-05–Glossary of Terms for Hollow Metal Doors & Frames, 8d, 2005
- 802-07–Manufacturing of Hollow Metal Doors & Frames, 8d, May 2007
- 803-08–Steel Tables, 8d, December 2008
- 805-10–Recommended Selection and Usage Guide for Hollow Metal Doors & Frames, 8d
- 810-09–Hollow Metal Doors, 8d
- 820-08–Hollow Metal Frames, 8d
- 830-02–Hardware Selection for Hollow Metal Doors & Frames, 8d, Jan. 2002
- 831-97–Hardware Locations for Hollow Metal Doors & Frames, 8d, May 1997
- 841-07–Tolerances and Clearances for Commercial Hollow Metal Doors & Frames, 8d, June 12, 2007
- 850-00–Fire-Rated Hollow Metal Doors & Frames, 3rd Edition, 8d, Feb. 2000
- 861-06–Guide Specifications for Commercial Hollow Metal Doors & Frames, 6th Edition, 8d, December 5, 2006
- 862-03–Guide Specifications for Commercial Security Hollow Metal Doors & Frames, 8d, August 26, 2003
- 863-04–Guide Specifications for Detention Security Hollow Metal Doors & Frames, 8d, January 26, 2005
- 867-06–Guide Specifications for Commercial Laminated Core Hollow Metal Doors & Frames, 8d, March 27, 2006
- 890-06–Technical Summary Hollow Metal

2.3.3 ASTM Standards

- F1450-05–Test Methods for Hollow Metal Swinging Door Assemblies for Detention Facilities (*under revision - 2011*)
- F1577-05–Test Methods for Detention Locks for Swinging Doors

- F1592-05–Test Methods for Detention Hollow Metal Vision Systems
 - F1643-05–Test Methods for Detention Sliding Door Locking Device Assembly
 - F1758-05–Test Methods for Detention Hinges Used on Detention-Grade Swinging Doors
 - F1915-05–Test Methods for Glazing for Detention Facilities
- 2.3.4 NAAMM DEMA – Detention Equipment
- 111900-09–Guide Specification for Basic Detention Equipment Requirements, 11, Dec. 2009

3. DOOR CLASSIFICATIONS

3.1 *Commercial Doors and Frames (CD)*

Commercial doors and frames are of heavy duty commercial grade and have no special detention requirements. Interior doors used in S-2 and S-3 inmate apartment suites shall be of lighter construction. Commercial doors on exterior or interior exits from a suite of spaces generally denote free egress occupancy. Interior commercial doors may however be used within an impeded egress occupancy as for offices, classrooms and other occupational or group activity areas.

3.2 *Detention Doors and Frames (DD)*

Detention doors and frames exceed heavy duty commercial grade construction and are used to restrict or control the movement of persons for security reasons. Detention doors are used generally on the envelope of areas requiring containment and impeded egress. There are four types of Detention Doors, namely:

- 3.2.1 DD1–Detention Door Medium Swing
- 3.2.2 DD1p–Detention Door Pivot (for special application)
- 3.2.3 DD2 sliding–Detention Door Maximum
- 3.2.4 DD2 swing–Detention Door Maximum

3.3 *Grilles (GL) Swing or Sliding*

Grilles are metal lattice screens used to control movement of persons while permitting visual surveillance. See Section A-3.

4. DOOR STYLE

TABLE A-5-1 – DOOR STYLES

(as illustrated on Plates A-3-3 and A-3-4 for grilles, A-5-1 and A-5-2 for doors)¹:

Style	Name	Location examples
A	Two Half Lights	<ul style="list-style-type: none"> • Main Entrance • Observation cells (suicide watch)
B	Half Light	<ul style="list-style-type: none"> • Offices (Alternative 1) • Corridors • Control Post • Health Care
B2	Sidelight Frame Flush	<ul style="list-style-type: none"> • Offices (Alternative 2)
C	Narrow Light	<ul style="list-style-type: none"> • Inmate cells and bedrooms • Rooms requiring visual checks i.e. utility and storage rooms
D	Two Narrow Lights	<ul style="list-style-type: none"> • Security exterior entrances

¹ Using terminology from NAAMM HMMA 810-09, 8d, Hollow Metal Doors

Style	Name	Location examples
		<ul style="list-style-type: none"> • Stairways
E	Flush	<ul style="list-style-type: none"> • Service shafts • Washrooms • Mechanical rooms • Armoury
F	Dutch Door	<ul style="list-style-type: none"> • Counter service²
G	Grille	<ul style="list-style-type: none"> • Security Barrier in corridors or showers in segregation and maximum security ranges.
H	Overhead	<ul style="list-style-type: none"> • Shipping/Receiving, shop supply, areas requiring high openings for clearance

4.1 Door Light

- 4.1.1 For all security levels, all offices and areas of inmate/staff contact other than locations requiring an E style door must be observable from the adjacent circulation space through either a window in a door or an adjacent sidelight. The maximum height for the bottom edge of any light is 1300 mm from the floor (not accounting for the undercut which shall be 12 +/- mm).
- 4.1.2 Curtains, draperies and other decorative materials including textiles and films (i.e. reflective films) are not permitted in door lights except for :
- 4.1.2.1 Observation Cells (A) where it may be required to cover the extent of glass in the door to allow the cell to be used for other than observation purposes. In this case, a fabric could be held in place by 'Velcro'. Other glass covering options may be considered.
- 4.1.2.2 Bedroom doors in Women's minimum and medium security housing units. In this case privacy curtains on the corridor side of the door that allow control of the curtain by staff during security patrols and counts, and are made of fire resistant fabric held in place by 'Velcro' are permitted due to long standing practice at Women's Institutions that is in accordance with *Creating Choices*.

5. DOOR FUNCTIONS

5.1 Movement

- 5.1.1 A swing (**SG**) movement is achieved with the use of hinges or pins. The swing of doors shall be in accordance with good architectural practice when security is not a consideration. Cell doors shall swing outward into the corridor with a 180° swing. For free egress bedrooms, doors swing into the bedroom.
- 5.1.2 A pivot (**PV**) movement allows a door to rotate on a vertical axis at the centre line of the wall width. Under routine operations, the door swings into the room with a 90° swing, but can be made to swing into the corridor with a 90° swing by removing the door movement blocker. A door with this movement is not recommended for cell use since it does not sit within a frame and as such has gaps on both jambs and head. These gaps contribute to excessive light and sound penetration and potentially allow objects or liquids to pass to the

² Fire resistance rating of the room is to be considered in terms of latching and locking.

outside. It also poses certain problems when used with standard cell locks as the latch bolt is exposed on the cell side and any tampering is not readily visible.

5.1.3 A slide (**SL**) movement allows a door to slide to one side of its opening along the face of the wall. Sliding doors are moved by an electric motor and chain drive or by a pneumatic system.

5.1.4 Refer to *NAAMM/HMMA 801-05*³ for further terminology.

5.2 Locking

5.2.1 A Manual Lock (**LM**) operates mechanically by key one lock at the time.

5.2.2 A Remote Controlled Lock (**LR**) operates electromechanically or pneumatically from a control post. Locks are also mechanically keyed at the door and may be equipped with a local electric unlock when activated at the control post console.

5.2.3 There is no requirement for any locks or locking devices to have a mechanical gang release.

5.3 Operation

5.3.1 Manual (**M**) operation indicates that the opening or closing of a door is manually executed by staff or inmates.

5.3.2 Motorized (**MO**) operation indicates that the opening and closing of a door is achieved by a remote electric (or pneumatic) system.

6. TECHNICAL REQUIREMENTS

6.1 Commercial Doors (CD)

6.1.1 Commercial doors shall be of aluminum, solid core wood or composite, or hollow metal. All pressed steel hollow core metal doors and frames shall be of a minimum of 1.27mm (18ga) steel.

6.1.2 Glazing on doors or sidelights shall meet NBC requirements except for doors in medium and maximum security institutions where glazing shall be 6 mm tempered glass.

6.1.3 Door frames shall be compatible with the door for which they are intended. Reference is made to the *NAAMM/HMMA 820-08*⁴ – Hollow Metal Frame regarding frames for hollow metal door.

6.1.4 Commercial doors and frames shall have a minimum clear opening (door or hardware cannot interfere) of 810 mm x 2100 mm, unless specified otherwise⁵.

6.2 Detention Doors – Swing (DD1)

6.2.1 DD1 doors and frames shall have a minimum clear opening (door frame element or hardware cannot interfere with the clear opening) of 810 mm x 2100 mm, unless specified otherwise⁵.

6.2.2 DD1 doors shall be constructed of 2.0 mm (14ga) sheet steel both sides with total thickness of 50 mm. See standard *NAAMM/HMMA 863-04*⁶, specification CSI 08 34 63.13 – Steel Detention Doors and Frames (NMS 08 34 63)⁷ for additional details.

³ ANSI/NAAMM HMMA 801-05 – Glossary of Terms for Hollow Metal Doors and Frames

⁴ NAAMM/HMMA 820-08 – Hollow Metal Frame

⁵ Examples: Doorways in a public corridor or access to exit may be required to have a clear width 850 mm for detention or care occupancies (NBCC 3.3.3.4.(1)). Doorways through which it is necessary to move patients in bed shall have a clear width of at least 1050 mm (NBCC 3.3.3.4.(2)).

⁶ ANSI/NAAMM HMMA 863-04 – Guide Specifications for Detention Security Hollow Metal Doors and Frames, Fifth Edition, 8d January 2005. This standard has an Appendix with a thickness conversion table (page A-1). Measurement in the present document are all in mm, use this table for Imperial conversion.

⁷ Specifications 08000, 11190 & 11193 before 2004

- 6.2.3 DD1 doors of type C or D using narrow lights shall have 6 mm clear tempered glass. For larger glazing panels on detention doors, follow Section A-13 Control Post, Level B.
- 6.2.4 DD1 doors and frames are to be constructed as required in standard *NAAMM/HMMA 863-04* (see footnote 6) and specification CSI 08 34 63.13 – Steel Detention Doors and Frames (NMS 08 34 63). In addition, test reports shall be submitted from an independent testing laboratory certifying the following minimum performance of a typical Detention door, 860 x 2100 mm. Doors certified under *ASTM F1450-05*⁸ are acceptable. The following tests are applicable to DD1 and DD2 doors with minor differences in deflection as noted:
- 6.2.4.1 **Static Load:** Centrally apply load of 4000 kg at quarter points on door. Maximum deflection must not exceed 30 mm (15 mm for DD2). Permanent set not to exceed 10.0 mm (2 mm for DD2) after release of load (see Plate A-5-9).
- 6.2.4.2 **Rack Test:** Concentrate load of 2645 kg on one unsupported corner of door. Door must not fail. Deflection must not exceed 50 mm (35 mm for DD2) (see Plate A-5-10).
- 6.2.4.3 **Impact Load Test:** The door is mounted in a frame as in a normal cell setting. The door is subjected to a series of impact loads of 271 Joules following a pattern of targets from a pendulum ram (see Plate A-5-11). Impacts are delivered on the push side of the door⁹. The number of impacts for a DD-1 and DD-2 doors are:
- 200 lock or strike impacts (target 1)
 - 75 hinge impacts (targets 2, 3 & 4)
 - 100 corner panel impacts (target 5)
- 6.2.4.4 The door must remain operable after the test.
- 6.2.5 Plate A-5-3 illustrates typical DD1 swing door details.

6.3 **Detention Doors – Pivot (DD1p) [Not recommended for cell use]**

- 6.3.1 DD1p door size must account for pivot and 90° swing as well as the removable door stopper to achieve a minimum clear opening of 810 mm x 2100 mm.
- 6.3.2 DD1p doors shall be constructed of 2.0 mm (14ga) sheet steel both sides. See standard *NAAMM/HMMA 863-04*¹⁰, specification CSI 08 34 63.13 – Steel Detention Doors and Frames (NMS 08 34 63)¹¹ for additional details¹².
- 6.3.3 DD1p doors shall be type C as illustrated on Plate A-5-1. Narrow light glazing shall be 6 mm clear tempered glass.
- 6.3.4 DD1p pivot hardware is a pin/rod extending at both ends of the door. Bottom receiver is inserted in the floor during the pour of the slab. Top receiver is inserted in the door sill and has a removable housing to allow the door to be removed. Assembly must ensure rigidity of door (see note 10).

⁸ ASTM F1450 – 05 Standard Test Methods for Hollow Metal Swinging Door Assemblies for Detention Facilities

⁹ Procedure as with section 7.2.4 of ASTM F1450-05 Standard Test Methods for Hollow Metal Swinging Door Assemblies for Detention Facilities

¹⁰ ANSI/NAAMM HMMA 863-04 – Guide Specifications for Detention Security Hollow Metal Doors and Frames, Fifth Edition, 8d January 2005. This standard has an Appendix with a thickness conversion table (page A-1). Measurement in the present document are all in mm, use this table for Imperial conversion.

¹¹ Specifications 08000, 11190 & 11193 before 2004.

¹² There is no provision relating to pivot hardware in the NAAMM/HMMA standards.

6.3.5 DD1p doors are constructed in accordance with DD1 door requirements as noted in 6.2.4

6.3.6 Plate A-5-4 illustrates typical DD1p pivot door.

6.4 Detention Doors Maximum Slide (DD2)

6.4.1 The minimum clear opening for DD2 doors is 810 mm x 2100 mm. Door frame element or hardware must not infringe on the clear opening.

6.4.2 DD2 doors shall be constructed of 2.8 mm (12ga) sheet steel both sides with total thickness of 50 mm (see standard *NAAMM/HMMA 863-04* [see footnote 9]), specification CSI 08 34 63.13 – Steel Detention Doors and Frames (NMS 08 34 63) for additional details.

6.4.3 DD2 doors type C or D as illustrated on Plates A-5-1 and A-5-2 shall have narrow lights of 9 mm clear tempered glass. For larger glazed panels refer to Sections A-4 and A-12, Special Observation Cells, for glazing requirements where sized to enable passage.

6.4.4 DD2 cell doors have Food Pass/Cuff Port installed (see Plate A-5-8 for details).

6.4.5 DD2 doors and frames are to be constructed as required in standard *HMMA 863-04*¹³ and specification CSI 08 34 63.13 – Steel Detention Doors and Frames (NMS 08 34 63) and specification CSI 11 19 13 – Detention pass-through doors. In addition, test reports shall be submitted from an independent testing laboratory certifying the conformity to the tests outlined in section 6.2.4 for DD2 doors sized at 860 x 2130 mm. Manufacturer certified performance in accordance with *ASTM F1643-05*¹⁴ is also acceptable.

6.4.6 A 50 mm notch shall be provided in the door frame of sliding doors for emergency pry bar use. See Plates A-5-5 and A-5-7. The depth of the notch shall be sufficient to expose the edge of the door to allow the insertion of a pry bar to force the door open in the case of an emergency.

6.4.7 Plates A-5-5 illustrates typical DD2 sliding door and corridor arrangement and Plates A-5-6 and A-5-7 illustrate sliding door details.

6.5 Detention Doors Maximum Swing (DD2) [not for cells]

6.5.1 Swing DD2 doors and frames shall have a minimum clear opening of 810 mm x 2100 mm unless specified otherwise¹⁵.

6.5.2 Swing DD2 doors shall be constructed of 2.8 mm (12 ga) sheet steel both sides with total thickness of 50 mm. See standard *HMMA 863-04*¹⁶, specification CSI 08 34 63.13 – Steel Detention Doors and Frames (NMS 08 34 63)¹⁷ for additional details.

6.5.3 Swing DD2 doors type C or D as illustrated on Plates A-5-1 and A-5-2 shall have narrow lights of 9 mm clear tempered glass. For larger glazed panels as in doors

¹³ ANSI/NAAMM HMMA 863-04 – Guide Specifications for Detention Security Hollow Metal Doors and Frames, Fifth Edition, 8d January 2005. This standard has an Appendix with a thickness conversion table (page A-1). Measurement in the present document are all in mm, use this table for Imperial conversion.

¹⁴ ASTM F1643 – 05 Standard Test Methods for Detention Sliding Door Locking Device Assembly

¹⁵ Examples: Doorways in a public corridor or access to exit may be required to have a clear width 850 mm for detention or care occupancies (NBCC 3.3.3.4.(1)). Doorways through which it is necessary to move patients in bed shall have a clear width of at least 1050 mm (NBCC 3.3.3.4.(2)).

¹⁶ ANSI/NAAMM HMMA 863-04 – Guide Specifications for Detention Security Hollow Metal Doors and Frames, Fifth Edition, 8d January 2005. This standard has an Appendix with a thickness conversion table (page A-1). Measurement in the present document are all in mm, use this table for Imperial conversion.

¹⁷ Specifications 08000, 11190 & 11193 before 2004

for level 'A' control posts, glazing shall match that of the control post envelope as outlined in Section A-13 Security Control Posts.

- 6.5.4 Swing DD2s doors and frames are to be constructed as required in standard *HMMA 863-04* (see footnote 15), specification CSI 08 34 63.13 – Steel Detention Doors and Frames (NMS 08 34 63) and specification CSI 11 19 13 – Detention pass-through doors. In addition, test reports shall be submitted from an independent testing laboratory certifying the conformity to the tests outlined in section 6.2.4 for DD2 doors sized at 860 x 2130 mm. Manufacturer certified performance in accordance with ASTM F1643–05¹⁸ is also acceptable.

6.6 *Grilles (GL) Swing or Sliding*

See section A-3.

6.7 *Control Post Doors*

See Section A-13–Security Control Posts, Galleries and Routes: Level A and B Control Post doors.

6.8 *Service Chase Access Doors between cells*

All access doors for service shafts between cells shall be DD1 sized at 900 mm X 2100 mm to facilitate repair and maintenance.

¹⁸ ASTM F1643 – 05 Standard Test Methods for Detention Sliding Door Locking Device Assembly

7. DOOR SELECTION

Table A-5-1 coding is defined in Legend following table.

Inmate bedroom doors in S2 and S3 housing units swing into the room. All cell doors swing out.

TABLE A-5-1 – DOOR SELECTION

LOCATION	MEDIUM	MAXIMUM
Inmate Cell (Not applicable to free egress bedrooms where doors are CD)	DD1-SG-LE-M	DD2-SL-LE ¹⁹ -MO
Apartment entry and fire exit doors	DD1-SG-LE-M	N/A
Service chase doors	DD1-SG-LM-M	DD1-SG-LM-M
Housing Unit and Segregation Entrance and fire exit doors	DD1-SG-LE-M	DD2-SG-LE-M
Housing Unit Office Suite Entry and fire exit doors	DD1-SG-LE-M	DD2-SG-LE-M
Segregation cell doors	DD2-SL-LE-MO	DD2-SL-LE-MO
Health Unit Entrance and fire exit	DD1-SG-LE-M	DD1-SG-LE-M
Pharmacy / Dispensary	DD1-SG-LE-M	DD1-SG-LE-M
Nursing Station	CD-SG-LM-M	DD1-SG-LE-M
Patient room doors	CD-SG-LM-M	DD1-SG-LE-M
Partitions, Corridors	GL-SG-LM-M GL-SL-LE-MO	GL-SG-LM-M GL-SL-LE-MO
Inmate Program rooms and offices	CD-SG-LM-M	CD-SG-LM-M
Program and Admin Area Entrance	DD1-SG-LE-M	DD1-SG-LE-M
V & C Entry	CD-SG-LM-M DD1-SG-LE-M	CD-SG-LM-M DD1-SG-LE-M
Gatehouse: Vestibule Doors on both ends. Exterior door on outside of institution may be commercial type.	DD1-SG-LE-M	DD1-SG-LE-M

LEGEND FOR TABLE A-5-1

Classification

CD – Commercial Doors

DD1 – Detention Doors Swing

DD2 – Detention Doors Maximum Sliding or Swing

GL – Grilles Sliding or Swing

Movement

SG – Swing

PV – Pivot

SL – Slide

Locking

LM – Manual Lock

LE – Electric Lock

Operation

MO – Motorized

M – Manual

¹⁹ Doors are locked locally mechanically or by remote control of selected cell/cells. Doors lock in closed or open position

8. DOOR CONTROL

8.1 Door control for living unit doors may be integrated with other functions to be displayed graphically showing a representational floor plan on a touch screen type monitor in the control post. The design of the console /monitors and its functions is part of the security electronics specification and will be made available to the consultant as part of the Project Brief where applicable. Assistance by CSC experts will also be available during the development of these systems. Plates A-5-12 and A-5-13 are included only for illustration purposes to be tailored for a given project.

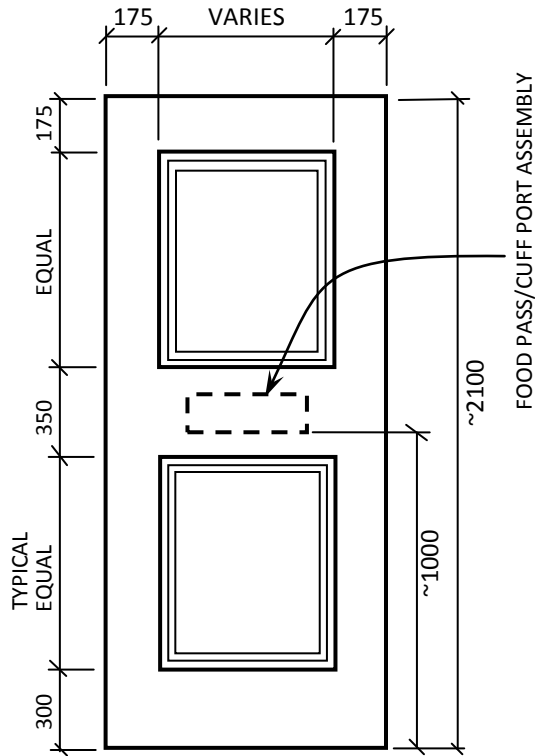

STYLE A – TWO HALF LIGHTS

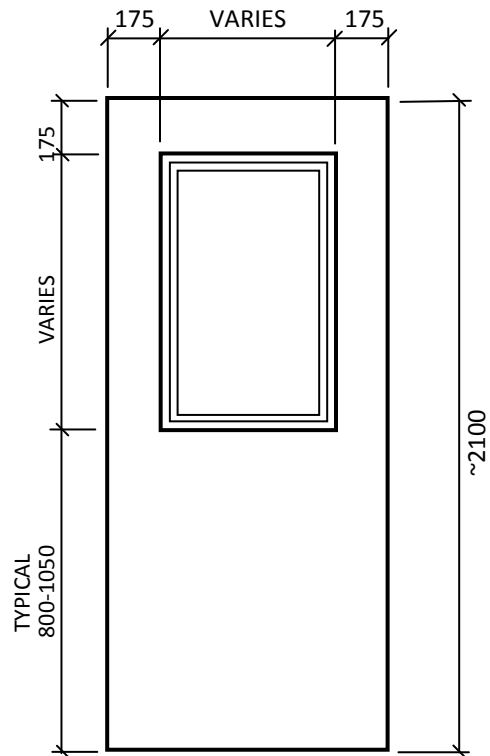

STYLE B – HALF LIGHT

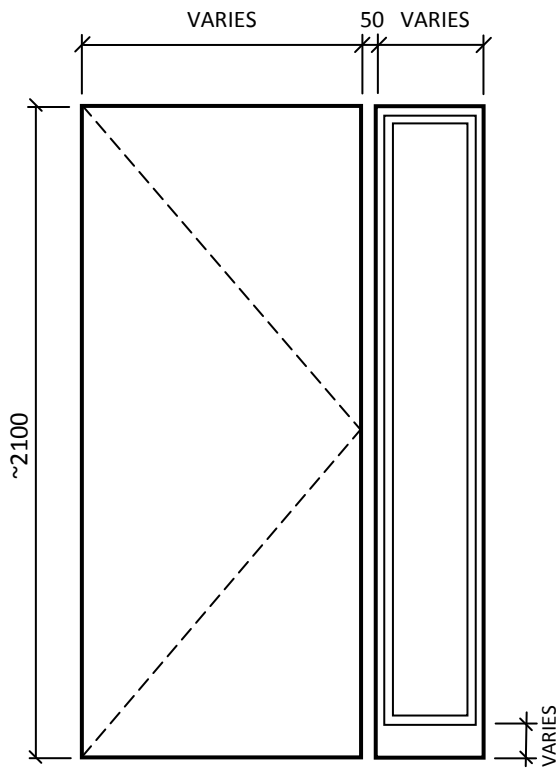

STYLE B2 – SIDELIGHT FRAME FLUSH

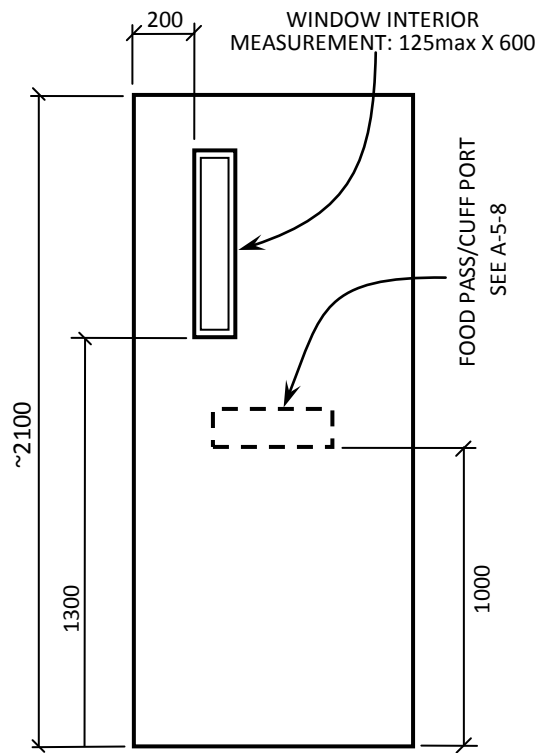

STYLE C – NARROW LIGHT

PLATE A-5-1 – DOOR STYLES – EXAMPLES OF APPLICATION PART 1

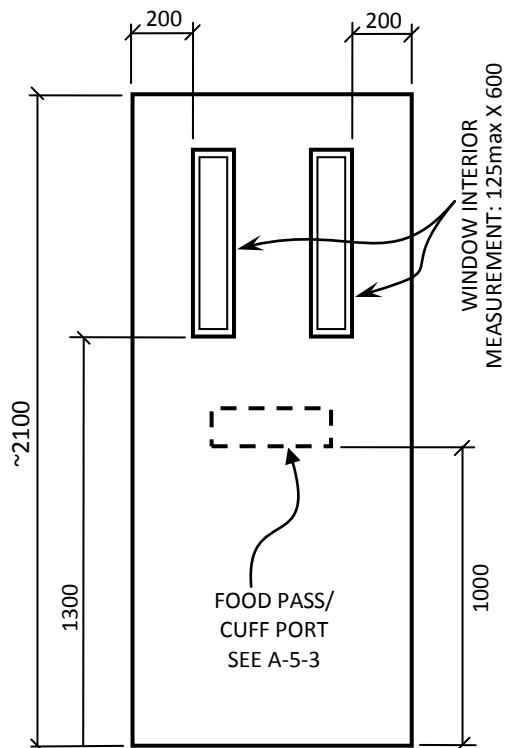

STYLE D – TWO NARROW LIGHTS

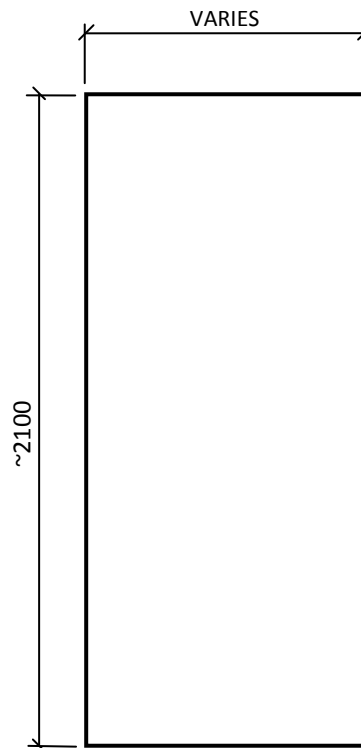

STYLE E – FLUSH

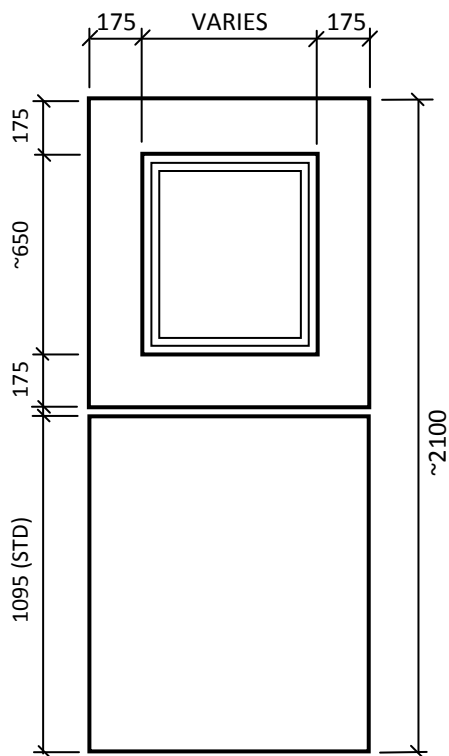

STYLE F – DUTCH DOOR

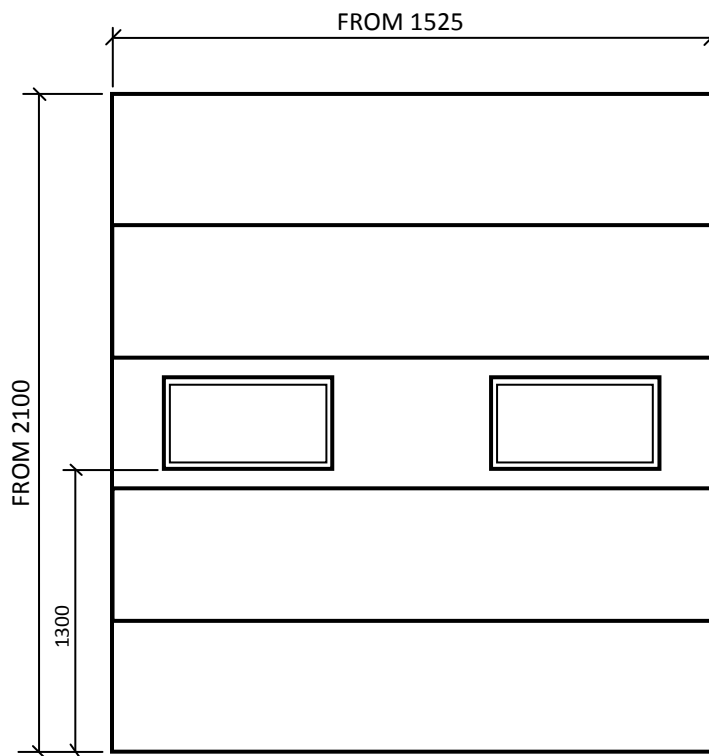

STYLE H – OVERHEAD

PLATE A-5-2 – DOOR STYLES – EXAMPLES OF APPLICATION PART 2

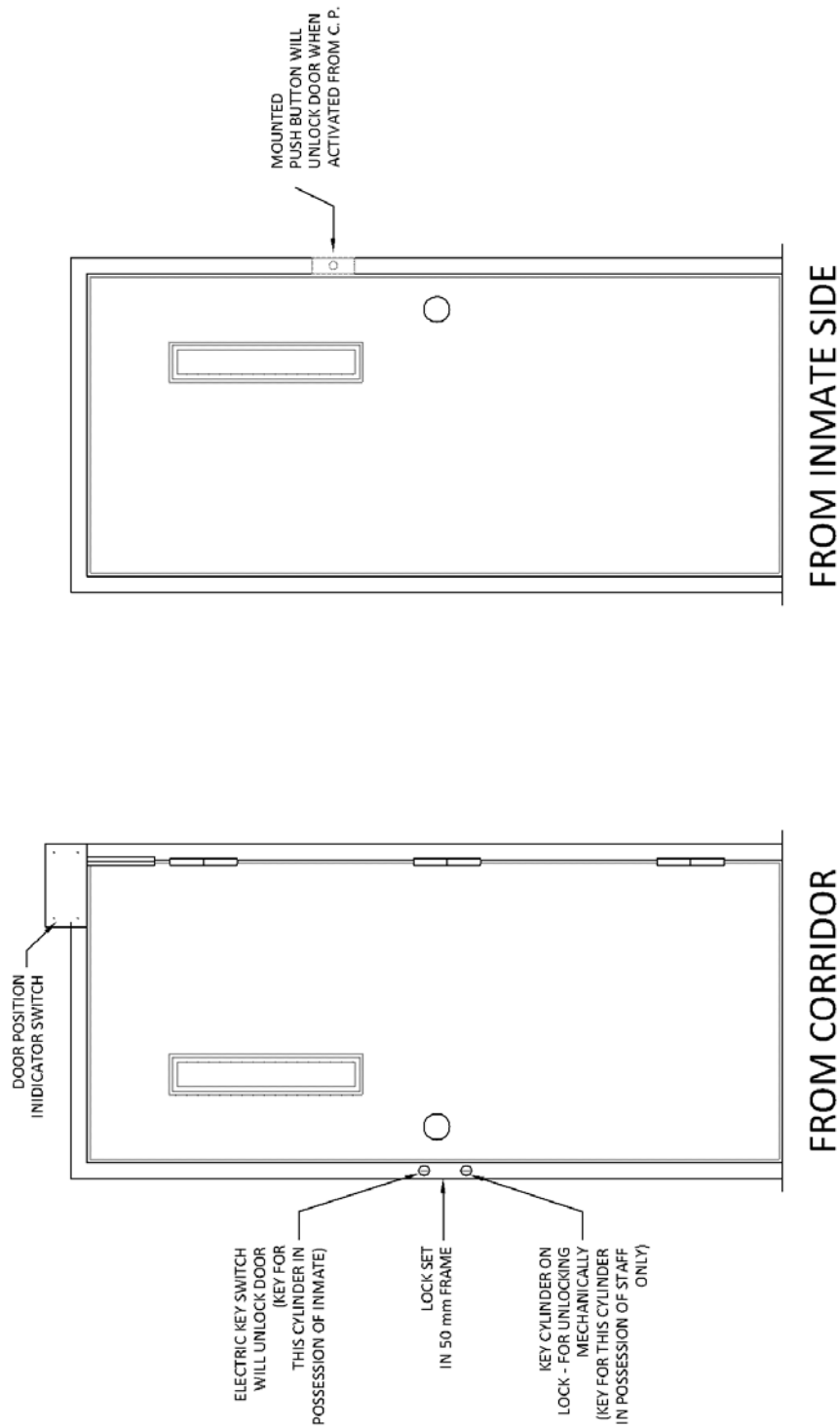

A-5-3 – ELEVATION OF DD1 SWING DOOR

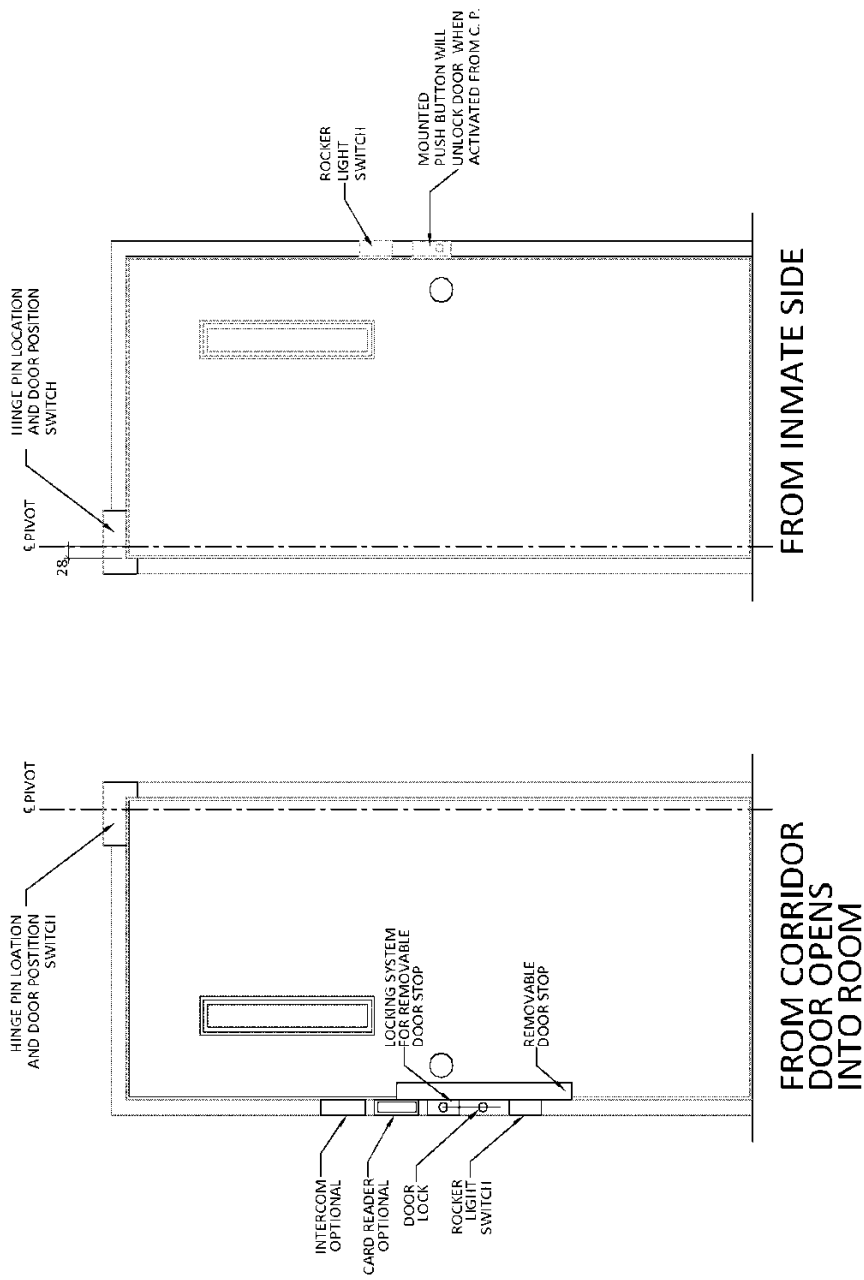

A-5-4 – ELEVATION OF DD1p PIVOT DOOR

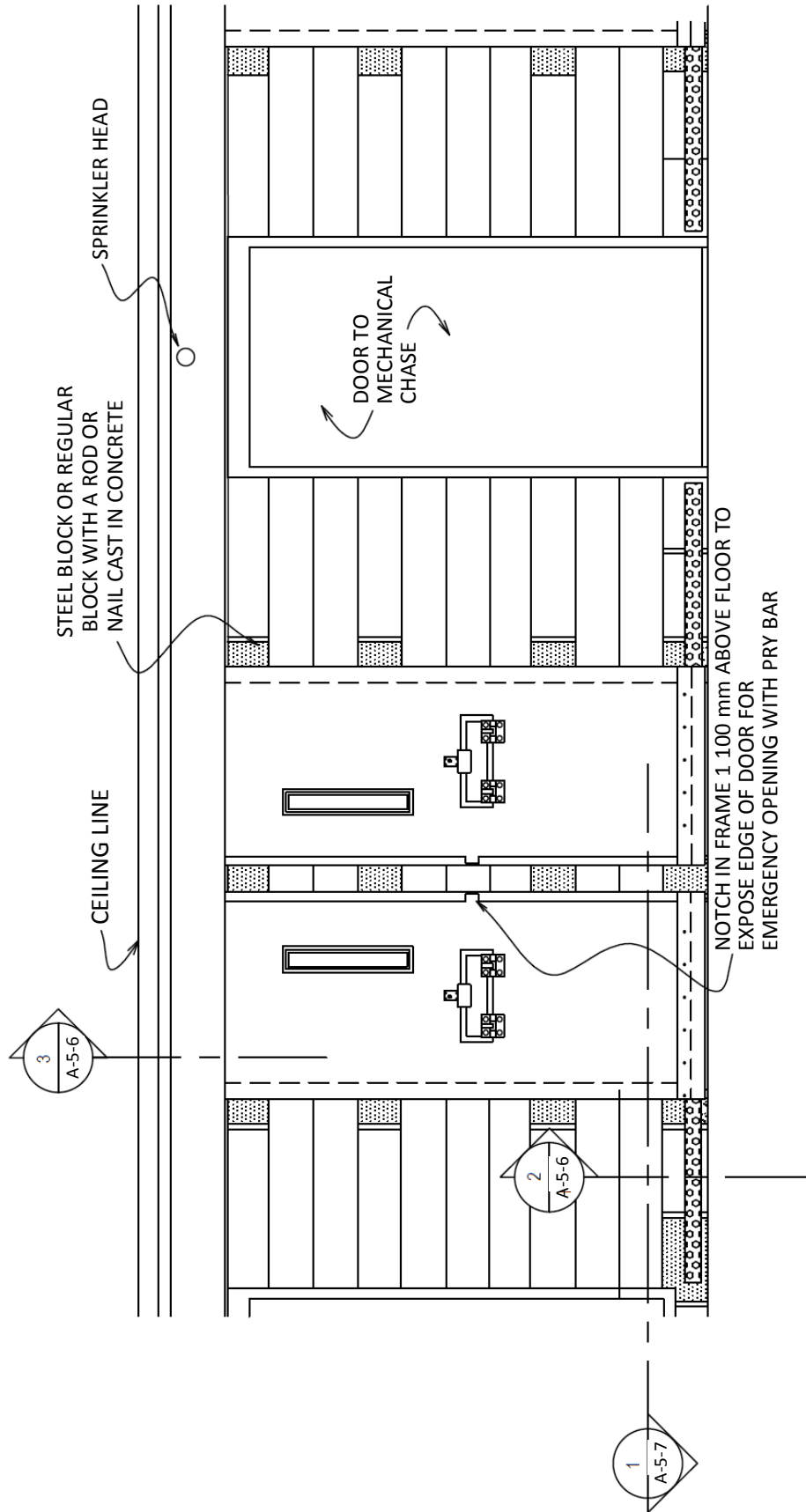
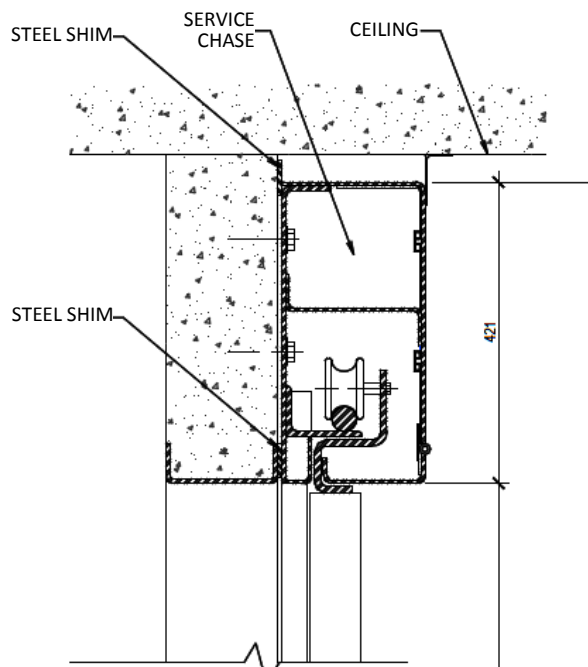
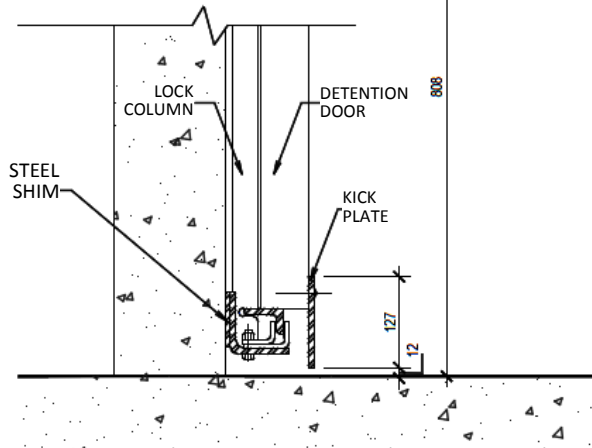

PLATE A-5-5 – CORRIDOR ELEVATION OF TYPICAL DD2 SLIDING CELL DOOR



3
A-5-6

SECTION THRU DOOR AT OPENING



2
A-5-6

SECTION THRU DOOR BEYOND OPENING

SLIDING DOOR MOUNTED ON
150mm REINFORCED CONCRETE WALL
WITH LOW CEILING CONDITION

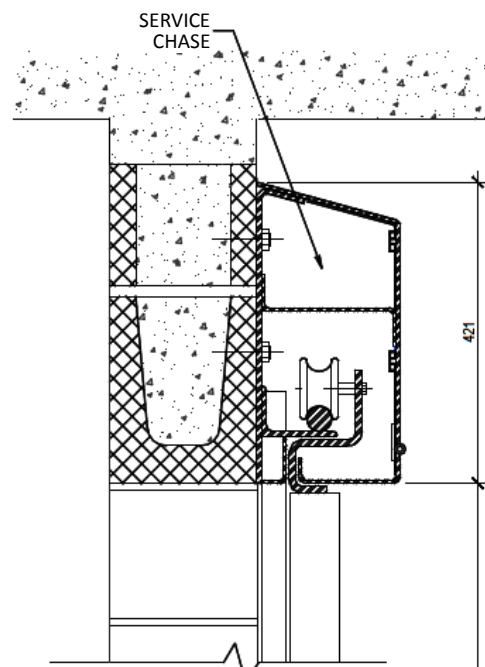

3
A-5-6

SECTION THRU DOOR AT OPENING

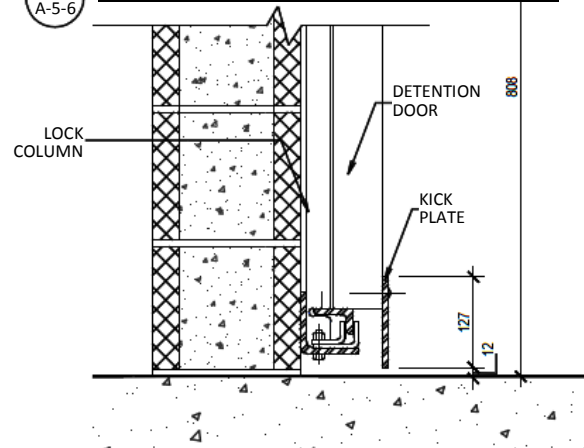

2
A-5-6

SECTION THRU DOOR BEYOND OPENING

SLIDING DOOR MOUNTED ON
200mm REINFORCED CONCRETE
BLOCK WITH STEEL BLOCKS @
SELECTED LOCATIONS

PLATE A-5-6 – TYPICAL DD2 SLIDING CELL DOOR – DETAILS 1

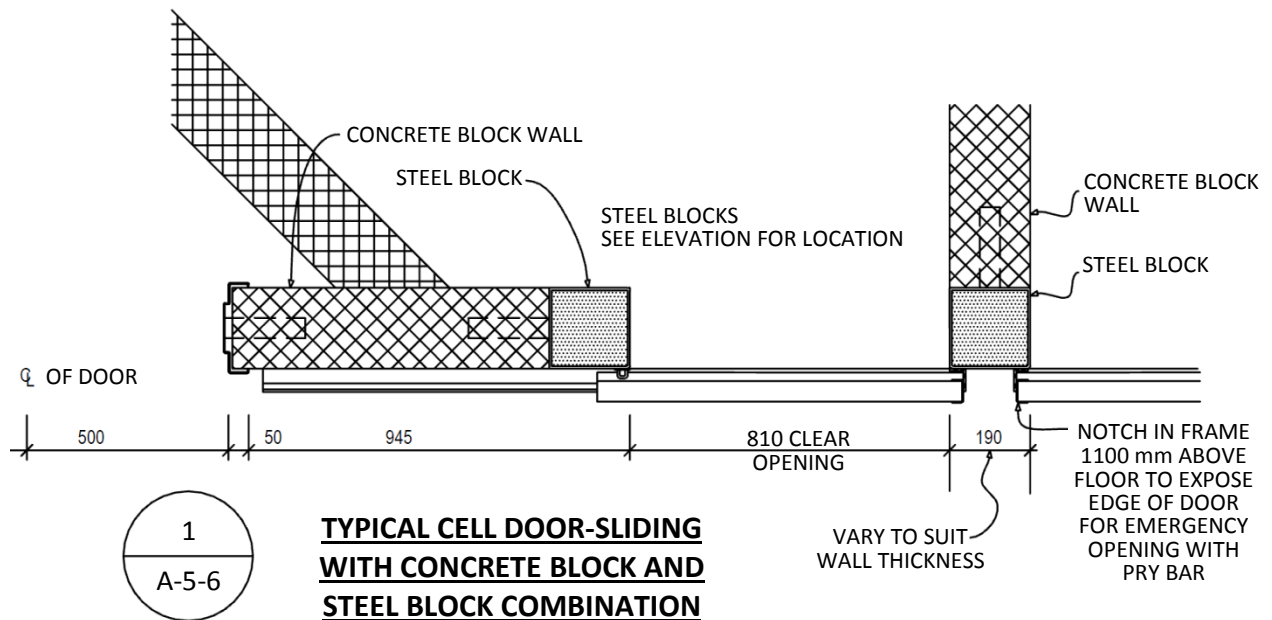
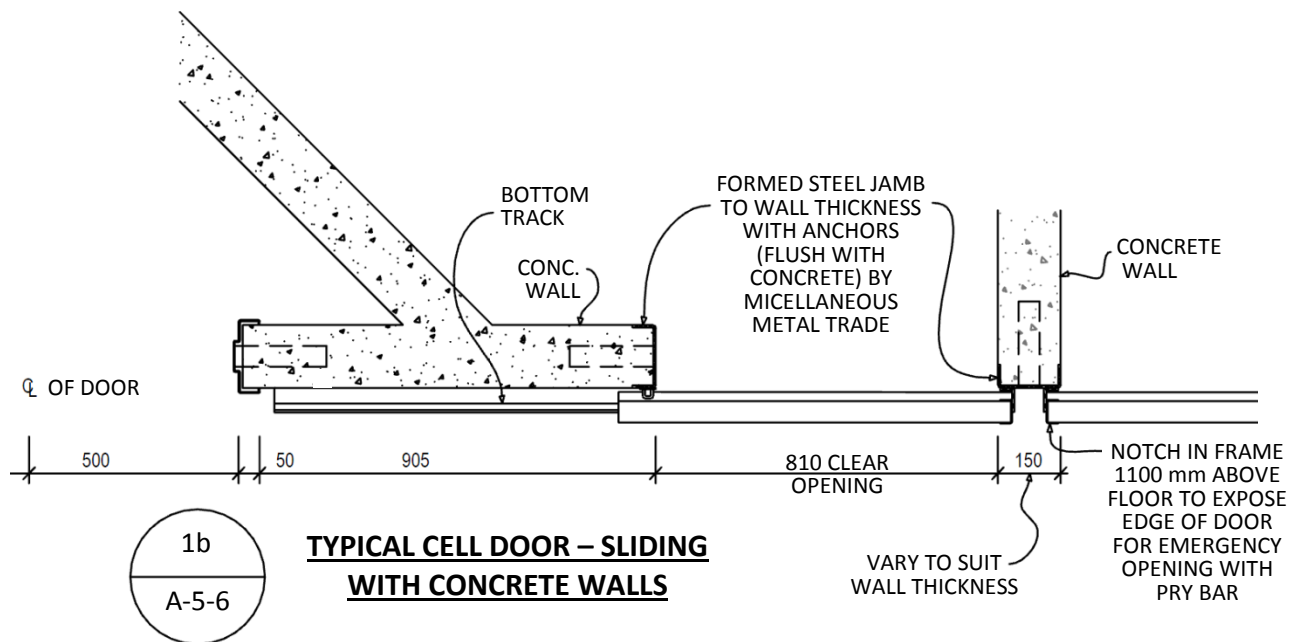
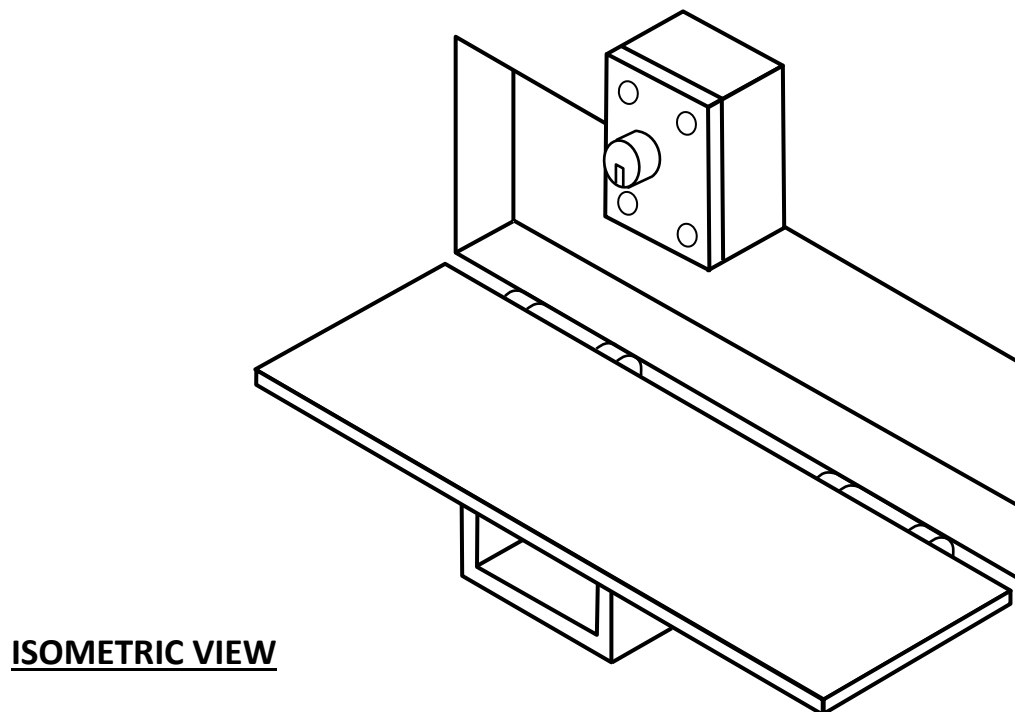
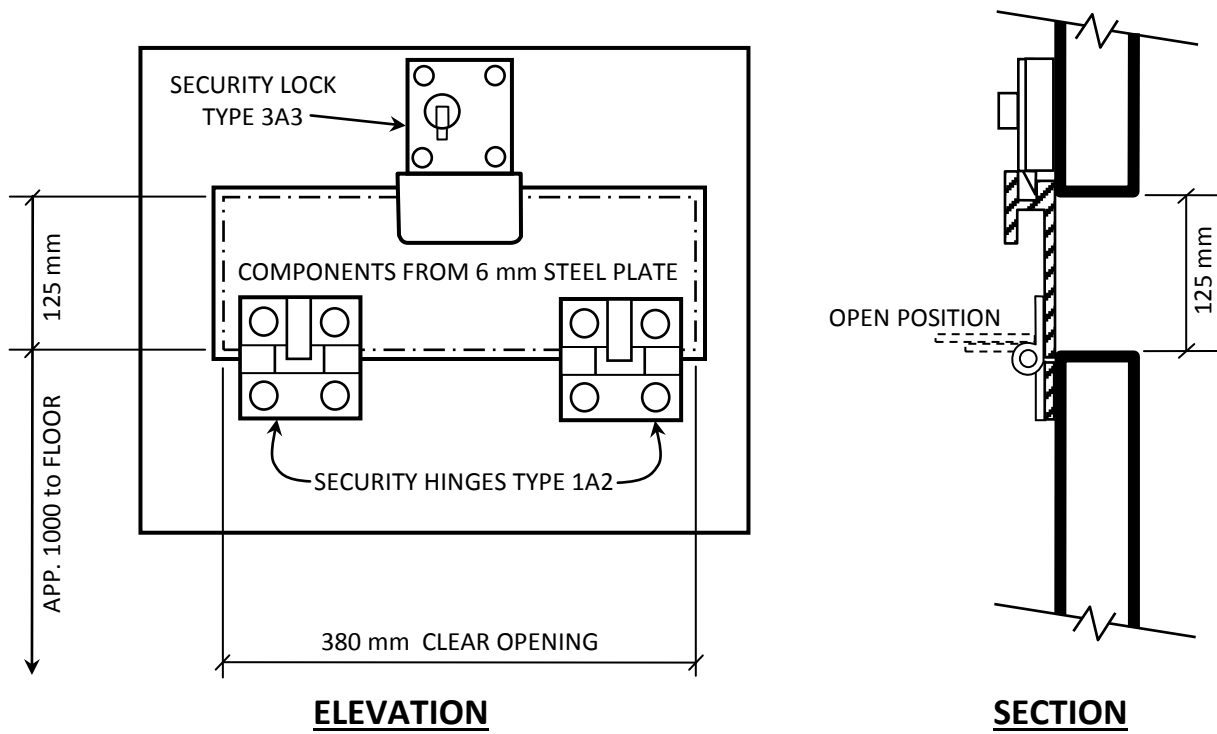
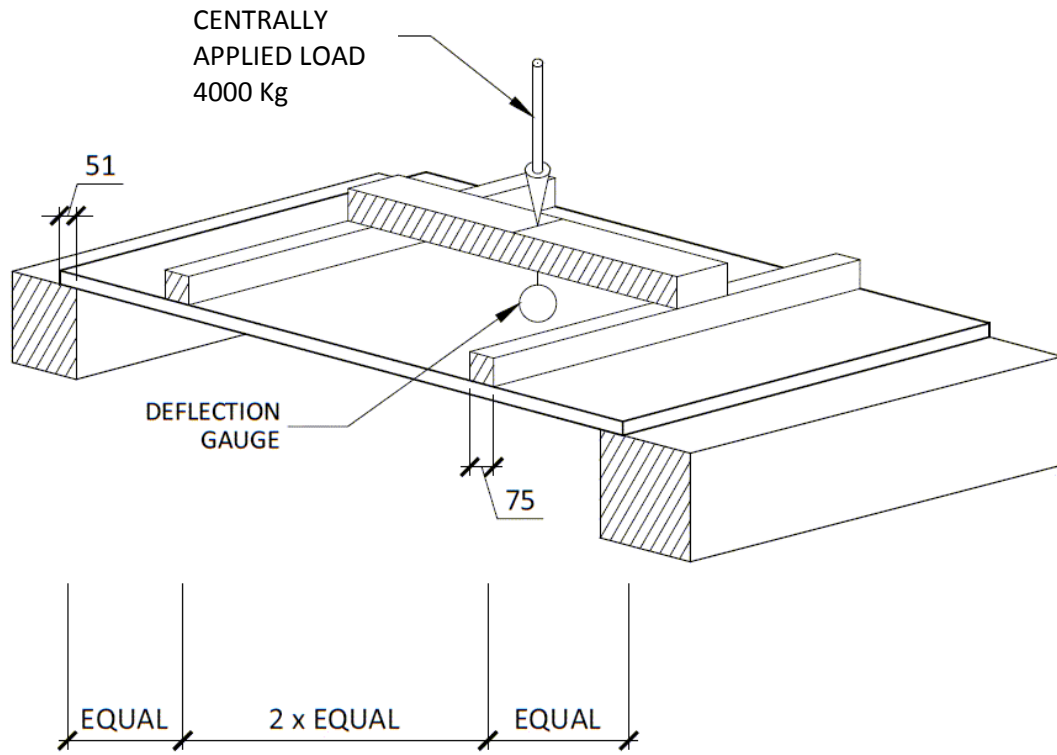

PLATE A-5-7 – TYPICAL DD2 SLIDING CELL DOOR – DETAILS 2



A-5-8 – FOOD PASS/CUFF PORT ASSEMBLY FOR DD2 DOOR



A-5-9 – DOOR STATIC LOAD TEST

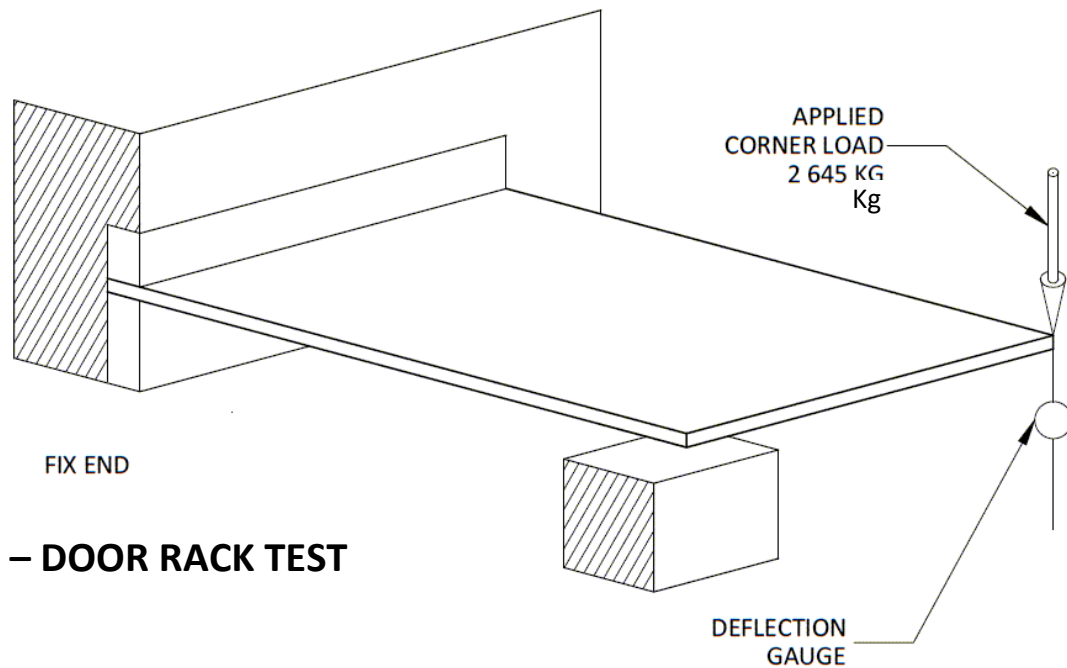

A-5-10 – DOOR RACK TEST

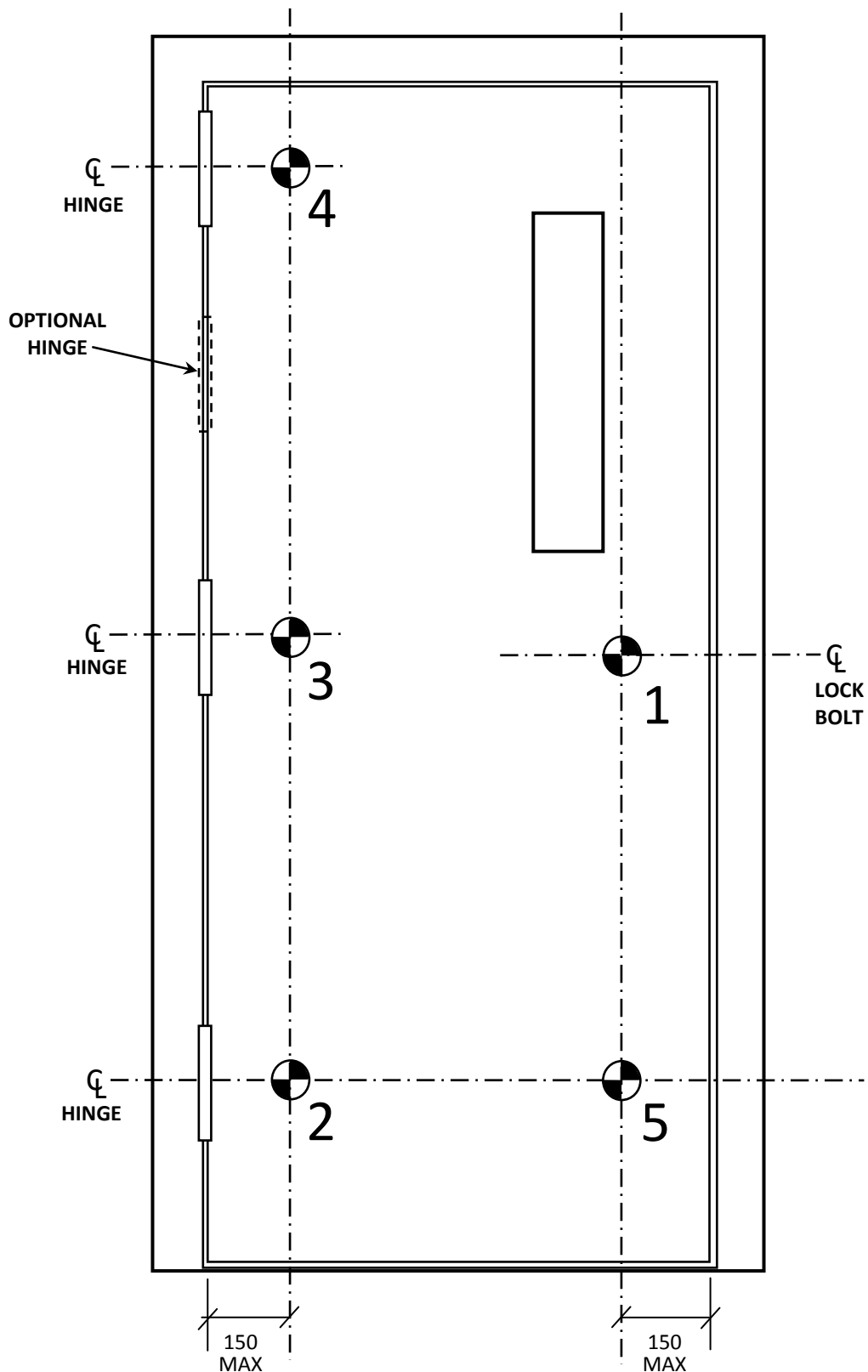

A-5-11 – DOOR ASSEMBLY IMPACT TEST

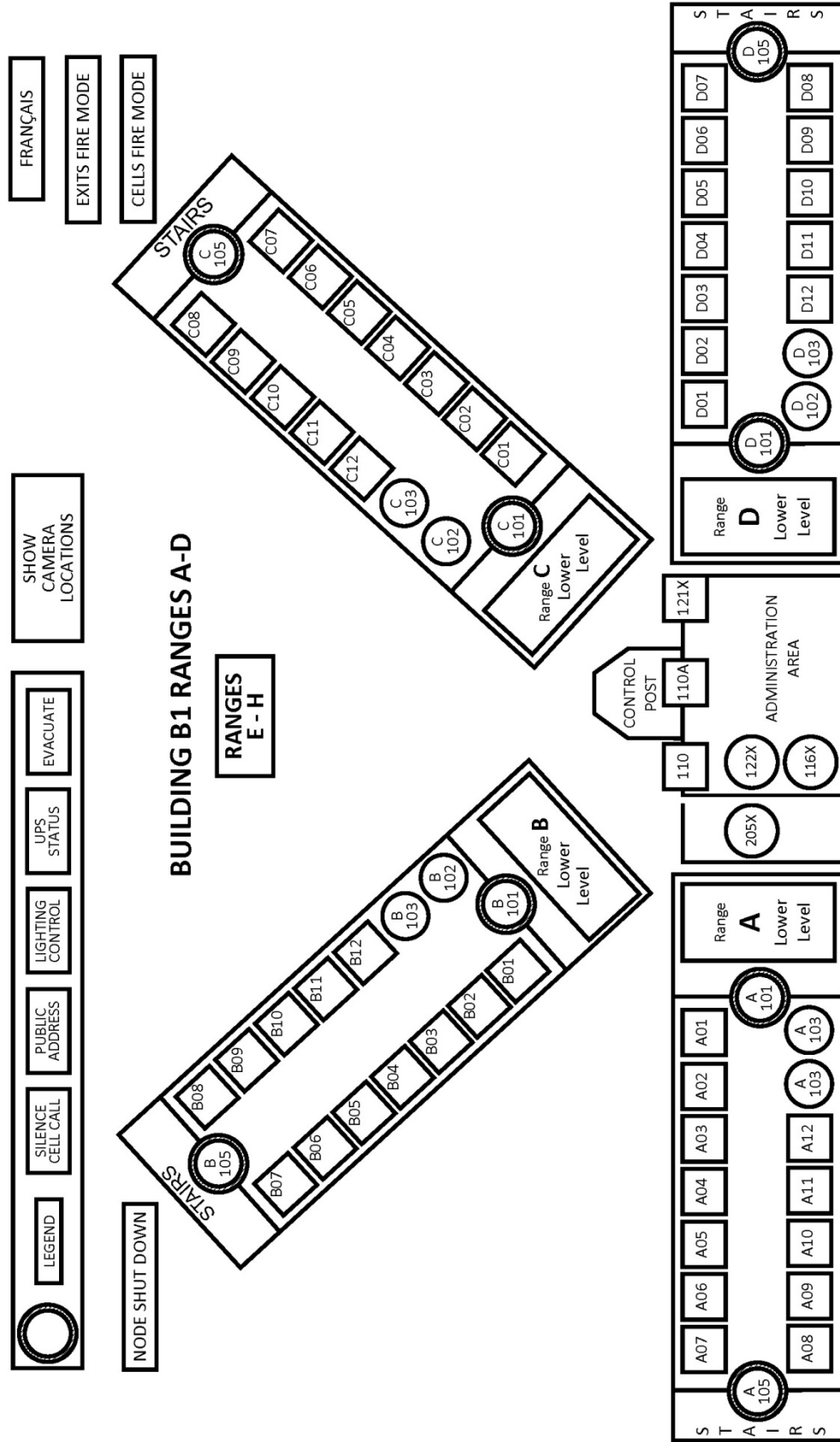

A-5-12 – CONSOLE – HOME

