

REVISION NO.	DESCRIPTION	DATE

THIS DRAWING TO BE READ IN CONJUNCTION WITH THE CONSTRUCTION MANUAL.

SIGNATURE:



Project Title / Titre du Projet  
 IRB  
 74 VICTORIA STREET  
 TORONTO, ON

Drawing Title / Titre du Dessin  
 2th FLOOR  
 FURNITURE PLAN

Date: 15 NOV 2019  
 Scale / Echelle: 1:300

Drawn by / Tracé par: AT  
 Checked by / Vérifié par:

Reference / Référence:

Drawing No.: 2-00

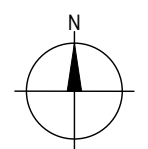

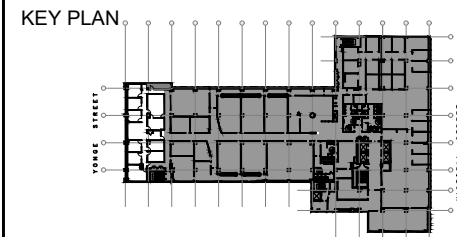
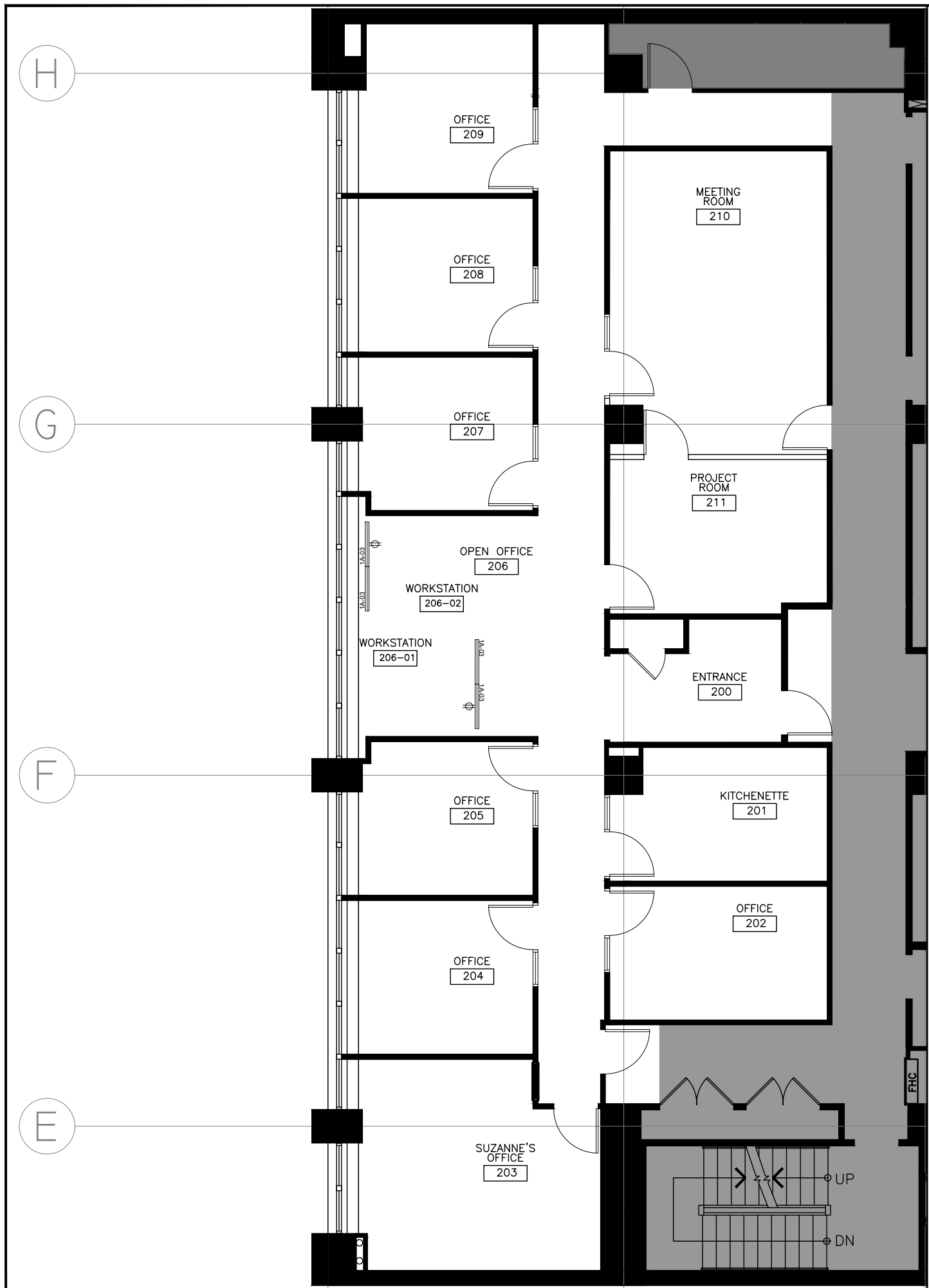

REVISION NO.	DESCRIPTION	DATE

THIS DRAWING TO BE READ IN CONJUNCTION WITH THE CONSTRUCTION MANUAL.

SIGNATURE:



Project Title / Titre du Projet  
 IRB  
 74 VICTORIA STREET  
 TORONTO, ON

Drawing Title / Titre du Dessin  
 2th FLOOR  
 FURNITURE PLAN  
 CATEGORY 1A & 1B

Date:  
 15 NOV 2019

Scale / Echelle  
 1:100

Drawn by / Tracé par  
 AT

Checked by / Vérifié par

Reference / Référence

Drawing No.:  
 2-01

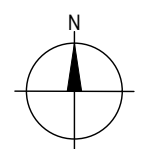

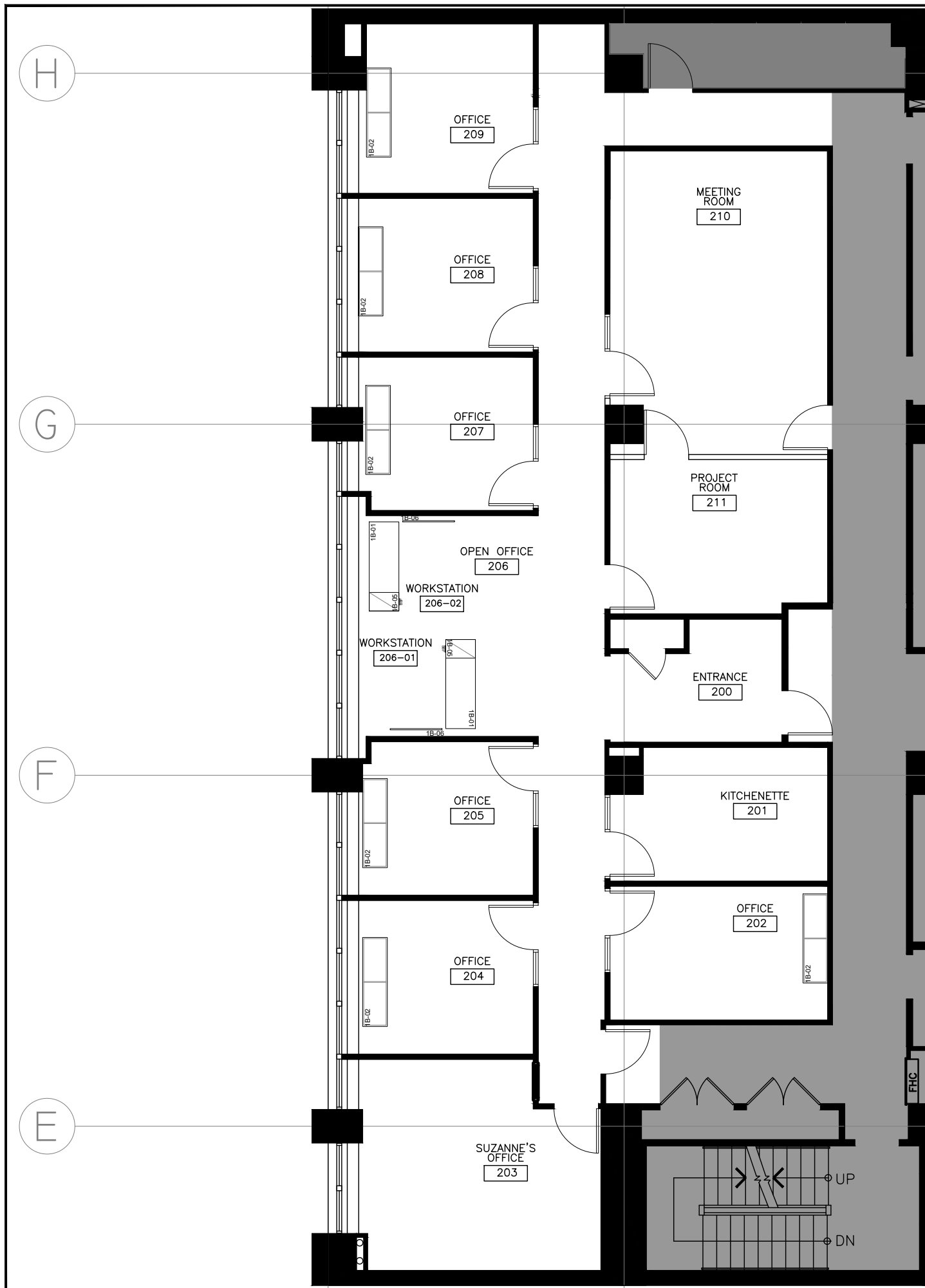

CATEGORY 1B



1B-01  
 FIXED HEIGHT WORKSURFACE, RECTANGULAR, 1 WORKSURFACE SUPPORT, 1 FULL GABLE, LAMINATED FINISH, WORKSURFACE WITH GROMMETS  
 SURFACES DE TRAVAIL À HAUTEUR FIXE, RECTANGULAIRE, SURFACE DE TRAVAIL, 1 CÔTÉ PLEINE HAUTEUR, STRATIFIÉ FINI, SURFACE DE TRAVAIL AVEC OUILLET  
 610MM (24") D X 1829MM (72") L X 737MM (29") H  
 QUANTITY: 2



1B-02  
 CREDENZA, PARTIAL HEIGHT, LAMINATED FINISH, RIGHT SIDE FILE DRAWER, KEYED DIFFERENTLY, LEFT SIDE DOOR, KEYED DIFFERENTLY  
 BAHUT, HAUTEUR PARTIELLE, STRATIFIÉ FINI, CÔTÉ DROIT TIROIR CLASSEUR, AVEC CLEF, CÔTÉ GAUCHE PORTE, AVEC CLEF  
 610MM (24") D X 1829MM (72") L  
 QUANTITY: 6



1B-05  
 FILING AND STORAGE, PEDESTALS BOX/BOX/FILE, WORKSURFACE SUPPORTING, LAMINATE FINISH, KEYED DIFFERENTLY  
 CLASSEURS ET ARMOIRES DE RANGEMENT, CAISSONS À TIROIR/TIROIR/CLASSEUR, SUPPORT DE SURFACE DE TRAVAIL, STRATIFIÉ FINI, AVEC CLEF  
 381MM (15") W X 610MM (24") D  
 QUANTITY: 2



1B-06  
 PRIVACY SCREENS, WORKSURFACE MOUNTED, FABRIC FINISH, PAINTED ALUMINUM FRAME, PANEL COVERED IN FABRIC HARMONIZED WITH THE FRAME, SCREENS MUST BE ABLE TO BE ADJUSTED TO DIFFERENT HEIGHTS  
 CLOISON D'INTIMITÉ, MONTÉES SUR SURFACE DE TRAVAIL, EN TISSU FINI, CADRE EN ALUMINIUM PEINT, PANNEAU RECOUVERT DE TISSU HARMONISÉ AVEC LE CADRE. LES ÉCRANS DOIVENT POUVOIR ÊTRE AJUSTÉS À DIFFÉRENTES HAUTEURS  
 1067MM (42") L X 915MM (36") H  
 QUANTITY: 2

KEY PLAN

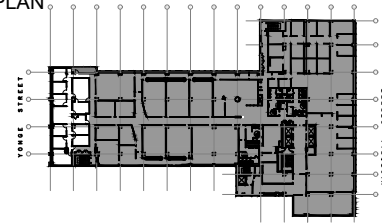

REVISION NO.	DESCRIPTION	DATE

THIS DRAWING TO BE READ IN CONJUNCTION WITH THE CONSTRUCTION MANUAL.

SIGNATURE:



Project Title / Titre du Projet

IRB  
 74 VICTORIA STREET

TORONTO, ON

Drawing Title / Titre du Dessin

2th FLOOR  
 FURNITURE PLAN  
 CATEGORY 1A & 1B

Date:  
 15 NOV 2019

Scale / Echelle  
 1:100

Drawn by / Tracé par  
 AT

Checked by / Vérifié par

Reference / Référence

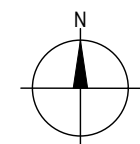

Drawing No.:

2-01

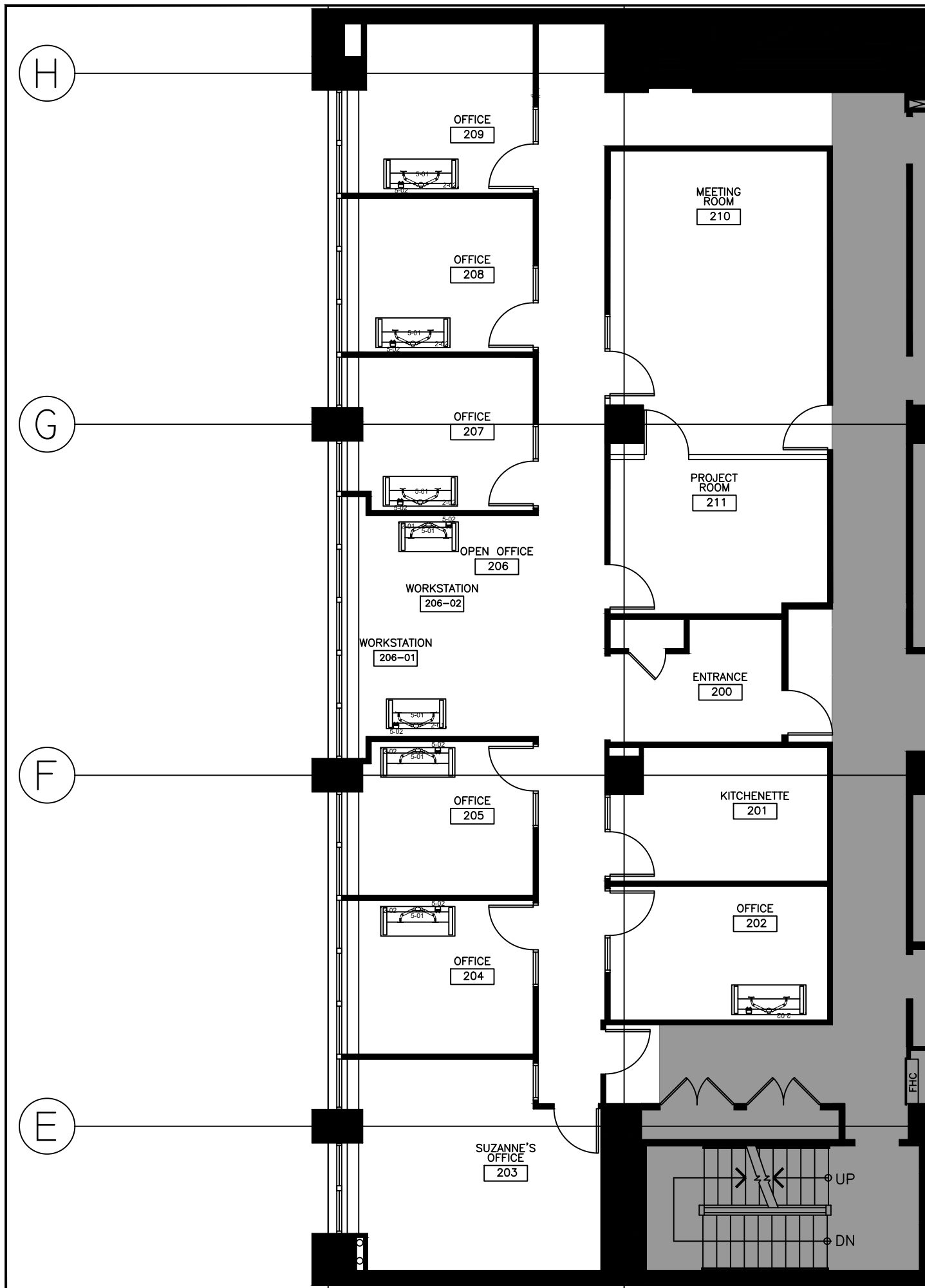

CATEGORY 2

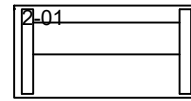

2-01  
INDIVIDUAL HEIGHT ADJUSTABLE WORKSURFACES,  
RECTANGULAR, HEIGHT ADJUSTABLE, LAMINATED FINISH,  
ELECTRICALLY CONTROLLED  
SURFACES DE TRAVAIL INDIVIDUELLES À HAUTEUR RÉGLABLE,  
RECTANGULAIRE, RÉGLABLE EN HAUTEUR, STRATIFIÉ FINI,  
CONTRÔLE ÉLECTRIQUEMENT  
762MM (30") D X 1219MM (48") L  
584MM (23") TO 1237MM (48.7") HEIGHT ADJUSTABLE  
QUANTITY: 2

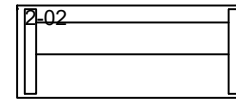

2-02  
INDIVIDUAL HEIGHT ADJUSTABLE WORKSURFACES,  
RECTANGULAR, HEIGHT ADJUSTABLE, LAMINATED FINISH,  
ELECTRICALLY CONTROLLED  
SURFACES DE TRAVAIL INDIVIDUELLES À HAUTEUR RÉGLABLE,  
RECTANGULAIRE, RÉGLABLE EN HAUTEUR, STRATIFIÉ FINI,  
CONTRÔLE ÉLECTRIQUEMENT  
762MM (30") D X 1524MM (60") L  
584MM (23") TO 1237MM (48.7") HEIGHT ADJUSTABLE  
QUANTITY: 6

CATEGORY 5



5-01  
DUAL MONITOR ARM, CLAMP MOUNT/  
SUPPORT D'ÉCRAN, DEUX BRAS, PINCE DE MONTAGE  
QUANTITY: 8



5-02  
POWER MODULE, WORK SURFACE MOUNTED, AC AND USB POWER  
MODULE D'ALIMENTATION, MONTÉ SUR SURFACE DE TRAVAIL,  
ALIMENTATION C.A. ET USB  
QUANTITY: 8

KEY PLAN

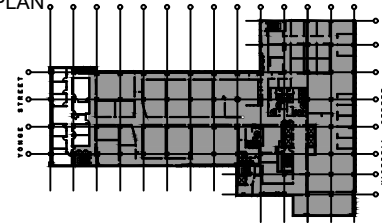

REVISION NO.	DESCRIPTION	DATE

THIS DRAWING TO BE READ IN CONJUNCTION WITH THE CONSTRUCTION MANUAL.

SIGNATURE:



Project Title / Titre du Projet

IRB  
74 VICTORIA STREET

TORONTO, ON

Drawing Title / Titre du Dessin

2th FLOOR  
FURNITURE PLAN  
CATEGORY 2 & 5

Date:  
15 NOV 2019

Scale / Echelle  
1:100

Drawn by / Tracé par  
AT

Checked by / Vérifié par

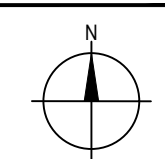

Reference / Référence

Drawing No.:

2-02

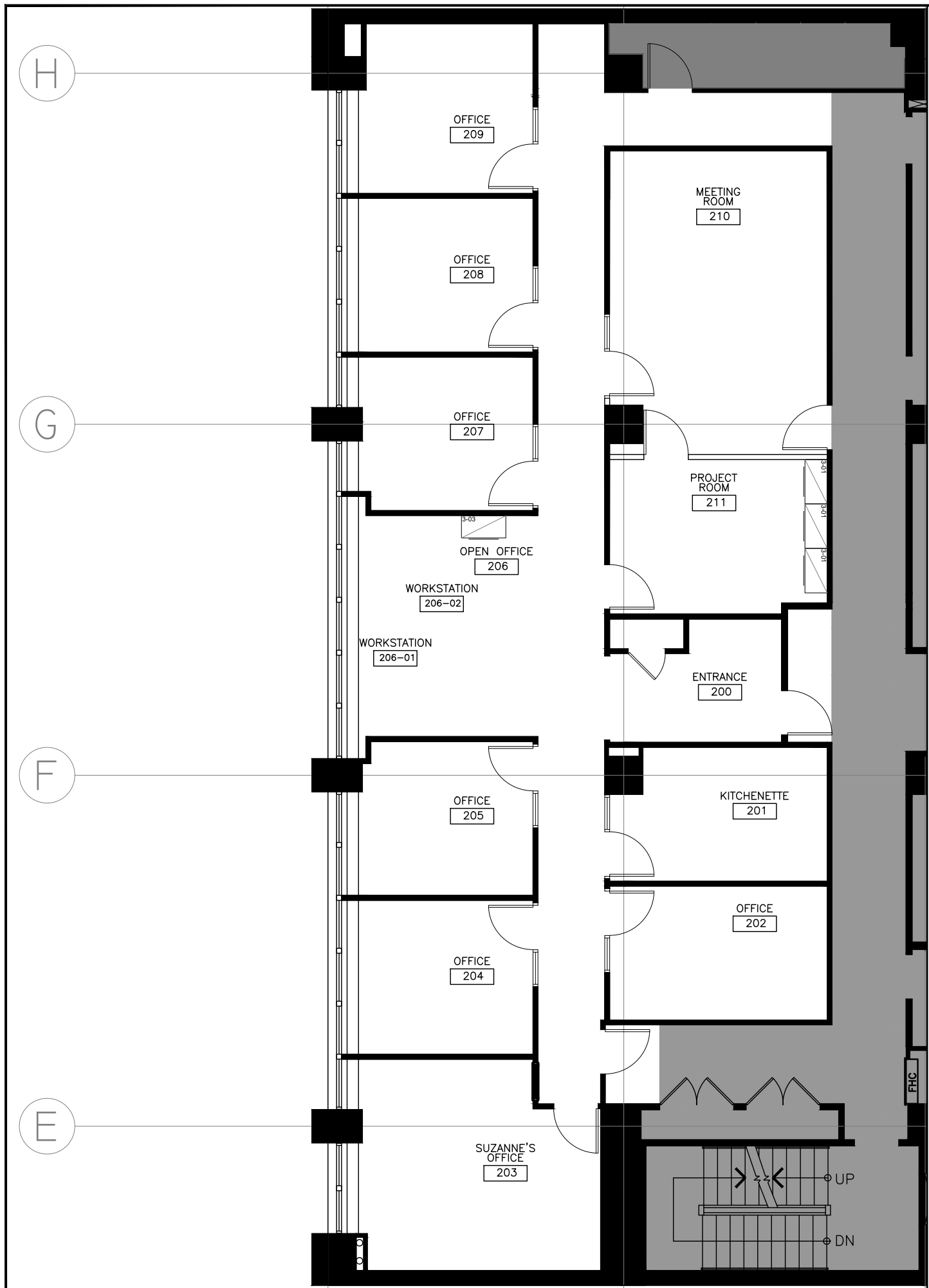

**CATEGORY 3**

3-01	<p>3-01 LATERAL FILING CABINET, 3 DRAWER, PAINTED METAL FINISH, KEYED CLASSEUR, LATÉRAL, 3 TIROIRS, MÉTAL PEINTURÉ FINI, AVEC CLEFS 457MM (18") X 915MM (36") QUANTITY: 3</p>
3-03	<p>3-03 LATERAL FILING CABINET, 4 DRAWER, PAINTED METAL FINISH, KEYED CLASSEUR, LATÉRAL, 4 TIROIRS, MÉTAL PEINTURÉ FINI, AVEC CLEFS 457MM (18") X 915MM (36") QUANTITY: 1</p>

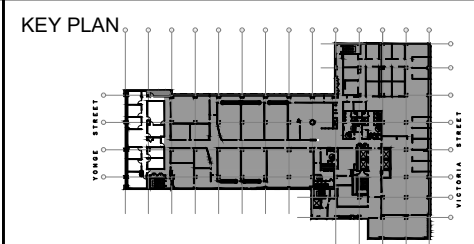

REVISION NO.	DESCRIPTION	DATE

THIS DRAWING TO BE READ IN CONJUNCTION WITH THE CONSTRUCTION MANUAL.

SIGNATURE:



Project Title / Titre du Projet  
 IRB  
 74 VICTORIA STREET  
 TORONTO, ON

Drawing Title / Titre du Dessin  
 2th FLOOR  
 FURNITURE PLAN  
 CATEGORY 3

Date: 15 NOV 2019  
 Scale / Echelle: 1:100

Drawn by / Tracé par: AT  
 Checked by / Vérifié par:

Reference / Référence:

Drawing No.: 2-03

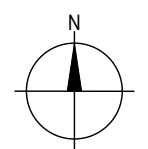

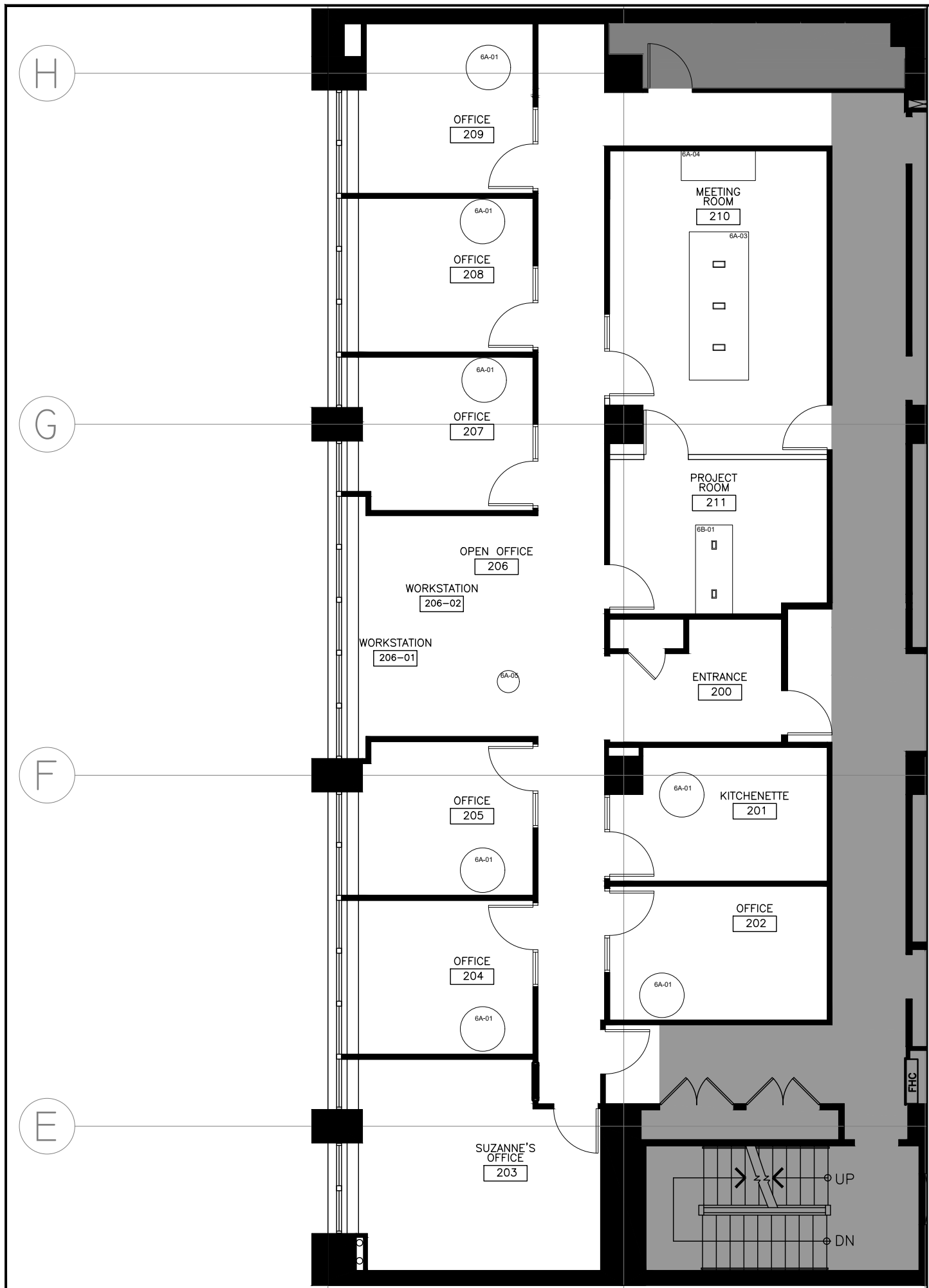

CATEGORY 6A - MEETING TABLES & CRENZENZA

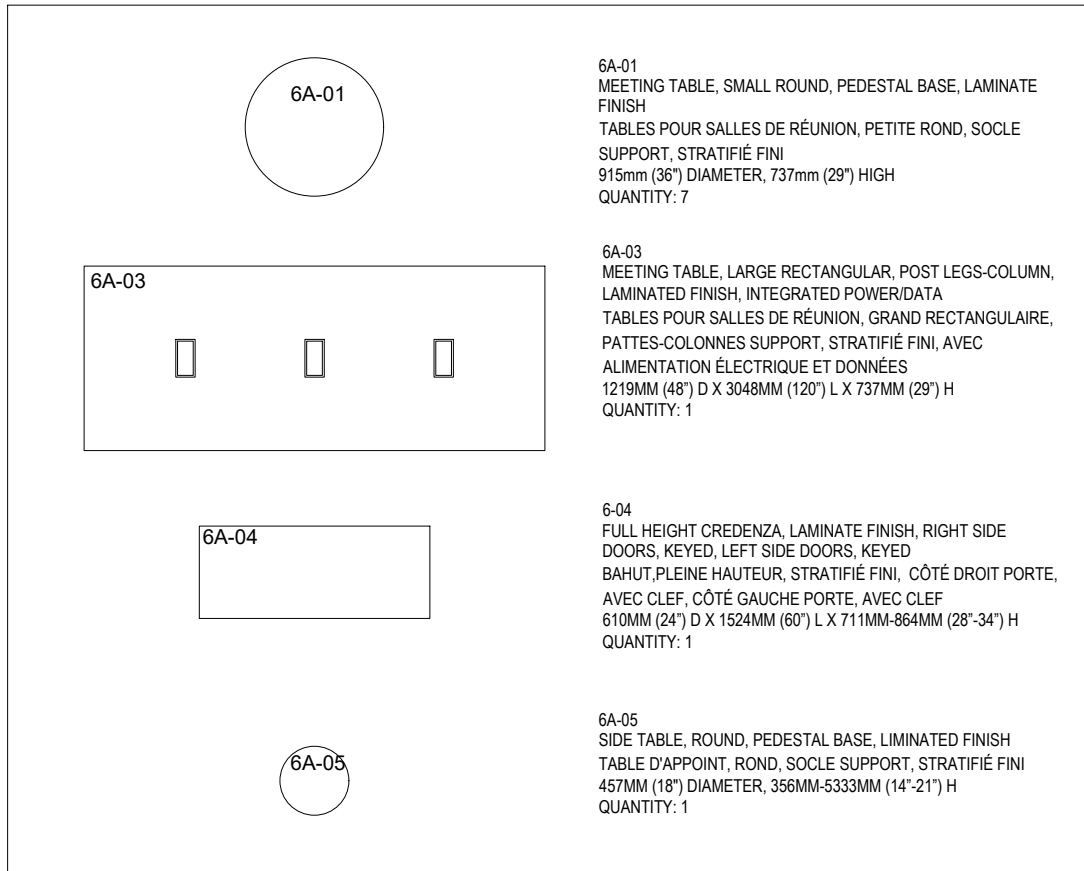

6A-01  
MEETING TABLE, SMALL ROUND, PEDESTAL BASE, LAMINATE FINISH  
TABLES POUR SALLES DE RÉUNION, PETITE ROND, SOCLE SUPPORT, STRATIFIÉ FINI  
915mm (36") DIAMETER, 737mm (29") HIGH  
QUANTITY: 7

6A-03  
MEETING TABLE, LARGE RECTANGULAR, POST LEGS-COLUMN, LAMINATED FINISH, INTEGRATED POWER/DATA  
TABLES POUR SALLES DE RÉUNION, GRAND RECTANGULAIRE, PATTES-COLONNES SUPPORT, STRATIFIÉ FINI, AVEC ALIMENTATION ÉLECTRIQUE ET DONNÉES  
1219MM (48") D X 3048MM (120") L X 737MM (29") H  
QUANTITY: 1

6A-04  
FULL HEIGHT CRENZENZA, LAMINATE FINISH, RIGHT SIDE DOORS, KEYED, LEFT SIDE DOORS, KEYED  
BAHUT, PLEINE HAUTEUR, STRATIFIÉ FINI, CÔTÉ DROIT PORTE, AVEC CLEF, CÔTÉ GAUCHE PORTE, AVEC CLEF  
610MM (24") D X 1524MM (60") L X 711MM-864MM (28"-34") H  
QUANTITY: 1

6A-05  
SIDE TABLE, ROUND, PEDESTAL BASE, LAMINATED FINISH  
TABLE D'APPOINT, ROND, SOCLE SUPPORT, STRATIFIÉ FINI  
457MM (18") DIAMETER, 356MM-533MM (14"-21") H  
QUANTITY: 1

CATEGORY 6B - COLLABORATIVE TABLES

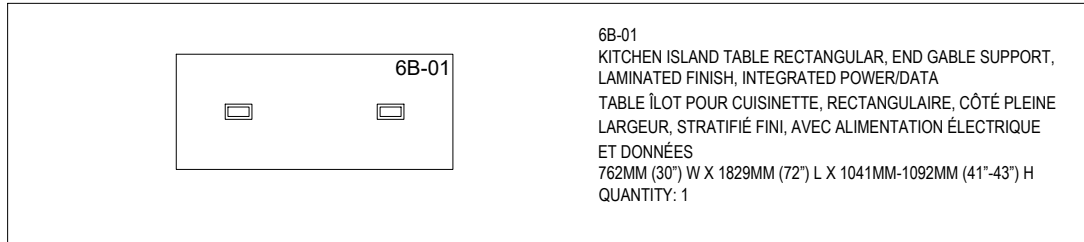

6B-01  
KITCHEN ISLAND TABLE RECTANGULAR, END GABLE SUPPORT, LAMINATED FINISH, INTEGRATED POWER/DATA  
TABLE ÎLOT POUR CUISINETTE, RECTANGULAIRE, CÔTÉ PLEINE LARGEUR, STRATIFIÉ FINI, AVEC ALIMENTATION ÉLECTRIQUE ET DONNÉES  
762MM (30") W X 1829MM (72") L X 1041MM-1092MM (41"-43") H  
QUANTITY: 1

KEY PLAN

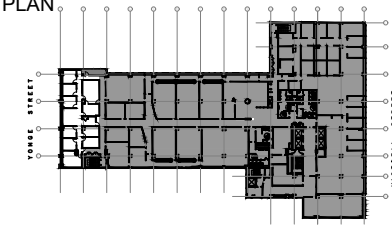

REVISION NO.	DESCRIPTION	DATE

THIS DRAWING TO BE READ IN CONJUNCTION WITH THE CONSTRUCTION MANUAL.

SIGNATURE:



Project Title / Titre du Projet

IRB  
74 VICTORIA STREET

TORONTO, ON

Drawing Title / Titre du Dessin

2th FLOOR  
FURNITURE PLAN  
CATEGORY 6A & 6B

Date:  
15 NOV 2019

Drawn by / Tracé par  
AT

Scale / Echelle  
1:100

Checked by / Vérifié par

Reference / Référence

Drawing No.:

2-04

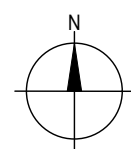

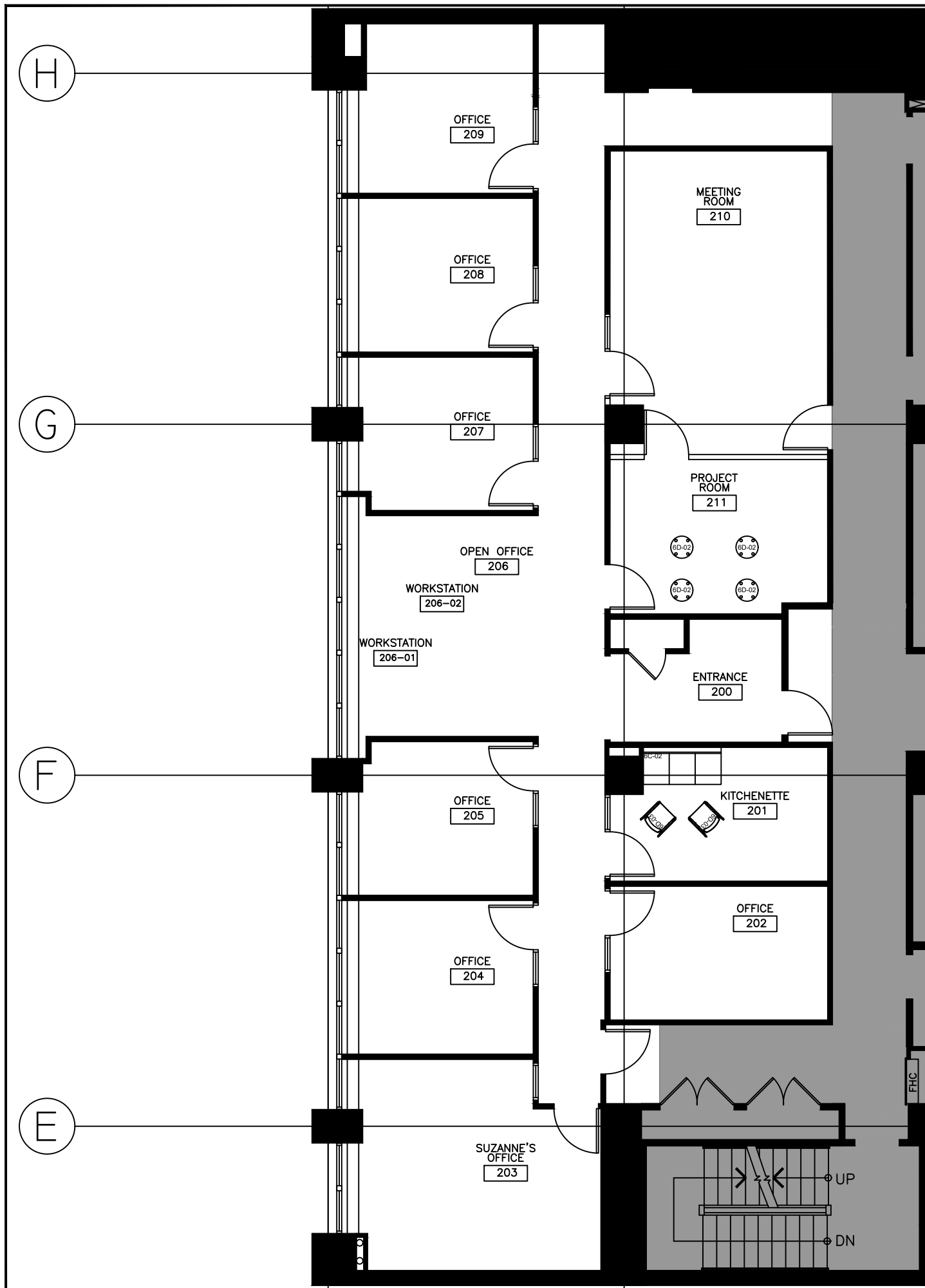

CATEGORY 6C - COLLABORATIVE SEATING

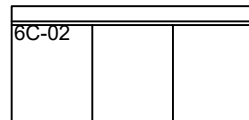

6C-02  
 BANQUETTE WITH BACKREST BOLSTER THREE-SEATER,  
 UPHOLSTERED, LEGS SUPPORT, MID BACK, NO ARMREST  
 BANQUETTE AVEC TRAVERSIN DE DOSSIER, TROIS PLACES,  
 REMBOURRÉ, PATTES SUPPORT, AVEC DOSSIER, PAS ACCOUDOIRS  
 1600MM-1905MM (63"-75") W X >483MM (>19") D  
 X 406MM-508MM (16"-20") H  
 QUANTITY: 1

CATEGORY 6D



6D-02  
 BAR STOOL, BAR HEIGHT, PEDESTAL BASE WITH CASTERS  
 POLYMER BACK AND FABRIC SEAT, WITH ARMREST, WITH SEAT  
 CUSHIONS  
 TABOURETS DE BAR, HAUTEUR BAR, SOCLE SUPPORT À  
 ROULETTES, DOS DE POLYMÈRE AVEC SIÈGE EN TISSU, AVEC  
 D'ACCOUDOIRS, AVEC COUSSINS DE SIÈGE  
 >381MM (>15") SEAT DEPTH  
 711M-813MM (28"-32") SEAT HEIGHT  
 QUANTITY: 4



6D-03  
 KITCHENETTE CHAIRS STANDARD HEIGHT, SLED BASE,  
 POLYMER, WITHOUT ARMREST, NO SEAT CUSHIONS  
 CHAISES DE CUISINETTE, HAUTEUR STANDARD, BASE  
 TRÂINEAU, POLYMÈRE, PAS D'ACCOUDOIRS, PAS COUSSINS DE  
 SIÈGE  
 >406MM (>16") SEAT DEPTH  
 432MM-508MM (17"-20") SEAT HEIGHT  
 QUANTITY: 2

KEY PLAN

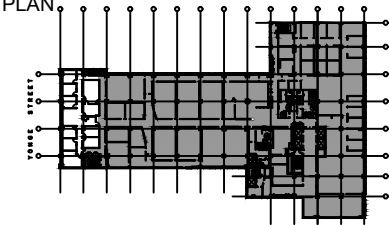

REVISION NO.	DESCRIPTION	DATE

THIS DRAWING TO BE READ IN CONJUNCTION WITH THE CONSTRUCTION MANUAL.

SIGNATURE:



Project Title / Titre du Projet

IRB  
 74 VICTORIA STREET

TORONTO, ON

Drawing Title / Titre du Dessin

2th FLOOR  
 FURNITURE PLAN  
 CHAIRS

Date:  
 15 NOV 2019

Scale / Echelle  
 1:100

Drawn by / Tracé par  
 AT

Checked by / Vérifié par

Reference / Référence

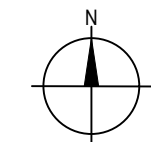

Drawing No.:

2-06

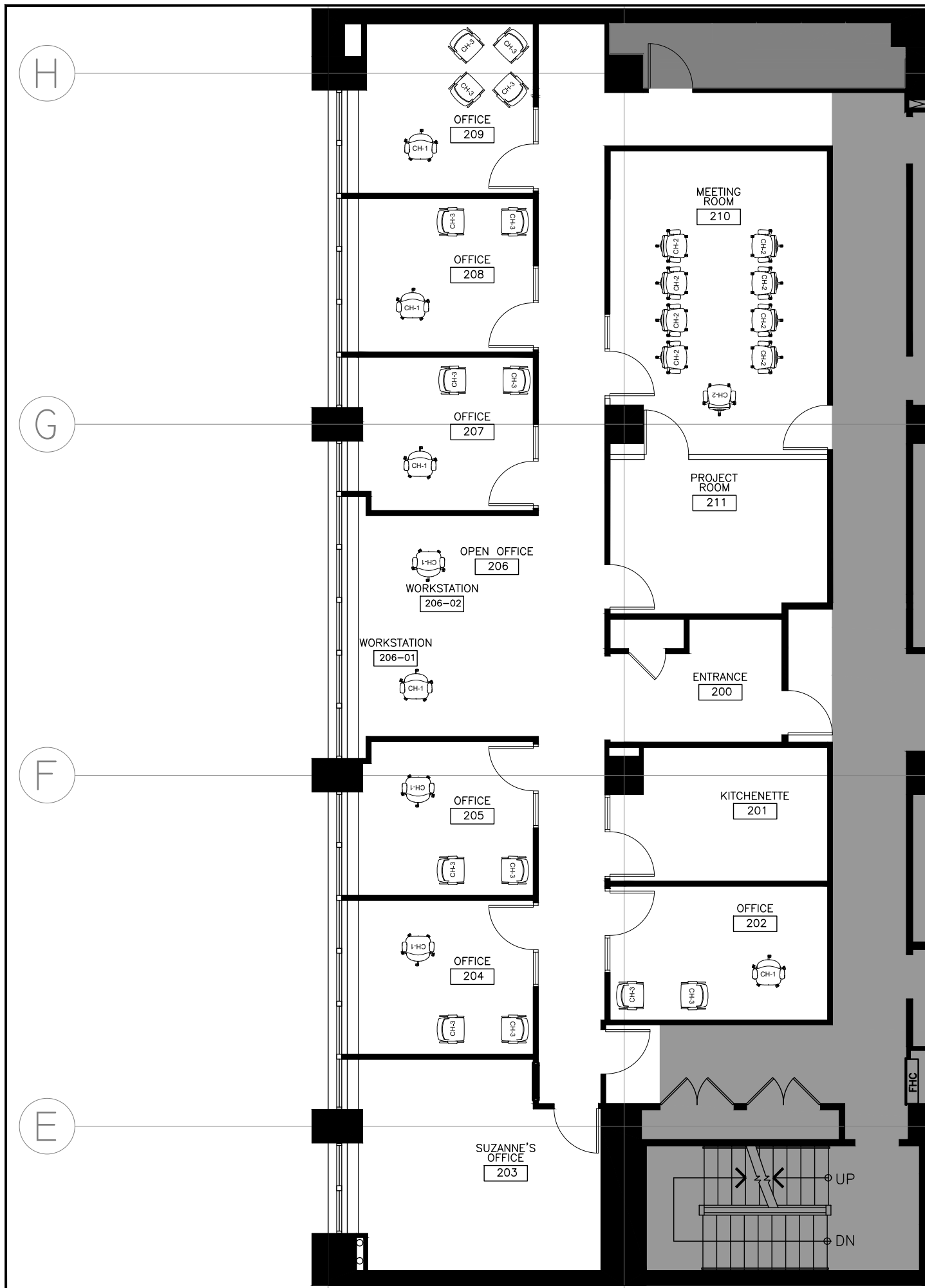

ROTARY, CONFERENCE AND SIDE CHAIRS/ FAUTEUIL DE BUREAU AI PIVOTANT, DE CONFÉRENCE ET DE VISITEUR

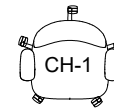

**CH-1**  
 ROTARY CHAIR/ FAUTEUIL DE BUREAU PIVOTANT  
 NO HEADREST, STANDARD/MID BACK  
 ADJUSTABLE LUMBAR SUPPORT AND SEAT DEPTH  
 T ARM ARMRESTS, ADJUSTABLE HEIGHT/WIDTH/SWIVEL  
 SEAT AND BACKREST LOCKABLE OR STOPPABLE IN MULTIPLE POSITIONS  
 TILT MECHANISM INDEPENDENTLY  
 UPHOLSTERY: BACK BREATHABLE MATERIAL/SEAT FABRIC/  
 AUCUN APPUIE-TÊT, HAUTEUR DU DOSSIER STANDARD  
 SUPPORT LOMBAIRE AJUSTABLE  
 ACCOUDOIRS : ACCOUDOIRS EN "T" AJUSTABLES EN HAUTEUR, LARGEUR ET EN INCLINAISON  
 PROFONDEUR DE SIÈGE: RÉGLABLE  
 VERROUILLAGES DU SIÈGE ET DU DOSSIER: VERROUILLABLE OU BLOQUABLE EN PLUSIEURS POSITIONS  
 MÉCANISME D'INCLINAISON: INDÉPENDAMMENT  
 REMBOURRAGE : REVÊTEMENT DU DOSSIER EN TISSU RESPIRANT/TISSU DU SIÈGE  
 QUANTITY: 8

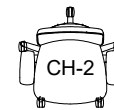

**CH-2**  
 CONFERENCE CHAIR/FAUTEUIL PIVOTANT DE CONFÉRENCE  
 NO HEADREST, STANDARD/MID-BACK  
 FIXED LUMBAR SUPPORT AND SEAT DEPTH  
 FIXED T ARM ARMRESTS  
 SEAT AND BACKREST LOCKABLE IN SETUP POSITION  
 TILT MECHANISM CONCURRENTLY  
 UPHOLSTERY: BACK BREATHABLE MATERIAL/SEAT FABRIC/  
 APPUIE-TÊT : AUCUN  
 HAUTEUR DU DOSSIER: DOSSIER STANDARD  
 SUPPORT LOMBAIRE: FIXE  
 ACCOUDOIRS : ACCOUDOIRS EN "T" FIXES  
 PROFONDEUR DE SIÈGE: SEMI-FIXE  
 VERROUILLAGES DU SIÈGE ET DU DOSSIER : VERROUILLABLE EN POSITION DE CONFIGURATION  
 MÉCANISME D'INCLINAISON : COMBINÉ  
 REMBOURRAGE : REVÊTEMENT DU DOSSIER EN TISSU RESPIRANT/TISSU DU SIÈGE  
 QUANTITY: 9



**CH-3**  
 SIDE CHAIR/FAUTEUIL DE VISITEUR  
 FOUR LEGS WITH CASTERS AND ARMRESTS  
 NON-STACKING  
 UPHOLSTERY:BACK BREATHABLE MATERIAL/SEAT FABRIC/  
 BASE À QUATRE PATTES AVEC ROULETTES ET ACCOUDOIRS  
 CAPACITÉ D'EMPILAGE: EMPILABLE  
 REMBOURRAGE : REVÊTEMENT DU DOSSIER EN TISSU  
 RESPIRANT/TISSU DU SIÈGE  
 QUANTITY: 14

KEY PLAN

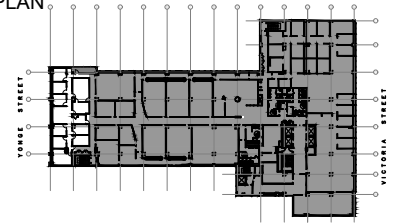

REVISION NO.	DESCRIPTION	DATE

THIS DRAWING TO BE READ IN CONJUNCTION WITH THE CONSTRUCTION MANUAL.

SIGNATURE:



Project Title / Titre du Projet

IRB  
74 VICTORIA STREET

TORONTO, ON

Drawing Title / Titre du Dessin

2th FLOOR  
FURNITURE PLAN  
CATEGORY 6C & 6D

Date:  
15 NOV 2019

Scale / Echelle  
1:100

Drawn by / Tracé par  
AT

Checked by / Vérifié par

Reference / Référence

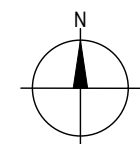

Drawing No.:

2-05



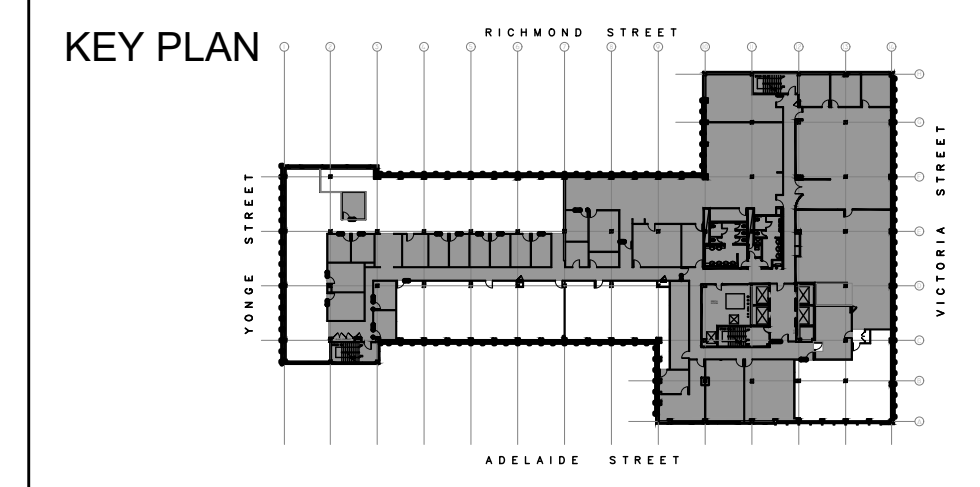
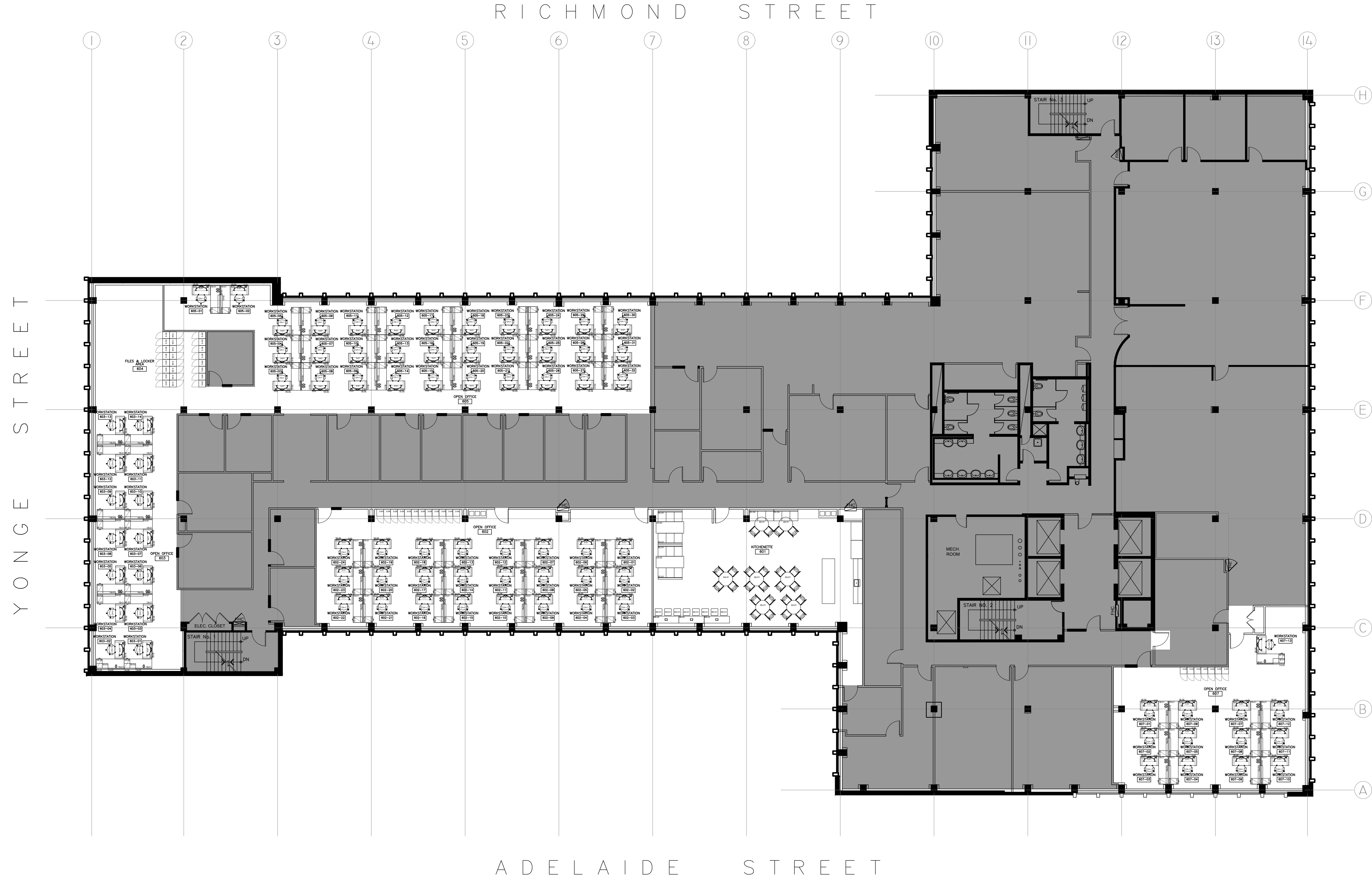

REVISION NO.	DESCRIPTION	DATE

THIS DRAWING TO BE READ IN CONJUNCTION WITH THE CONSTRUCTION MANUAL.

SIGNATURE:



Project Title / Titre du Projet  
**IRB**  
**74 VICTORIA STREET**  
 TORONTO, ON

Drawing Title / Titre du Dessin  
**6th FLOOR**  
**FURNITURE PLAN**  
**CHAIRS**

Date: <b>15 NOV 2019</b>	Scale / Echelle <b>1:150</b>
Drawn by / Tracé par <b>AT</b>	Checked by / Vérifié par
Reference / Référence	

	Drawing No.:
	<b>6-00</b>

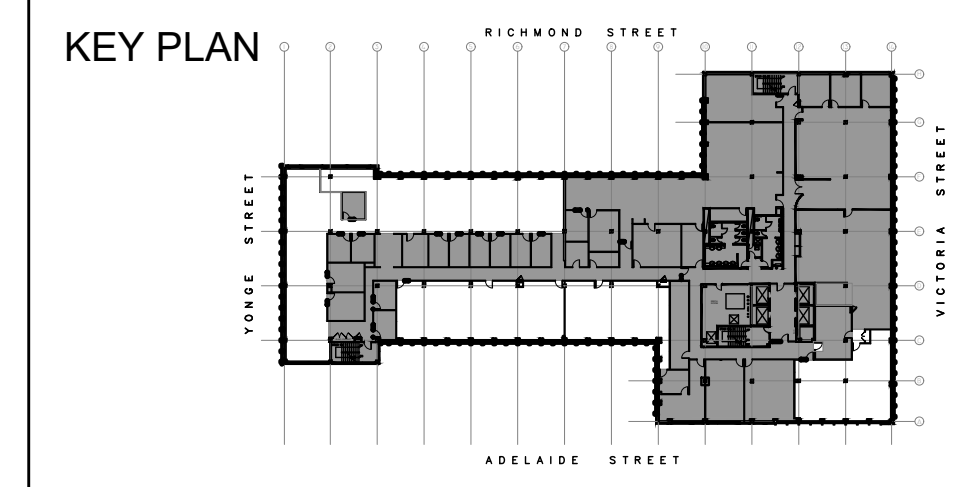

REVISION NO.	DESCRIPTION	DATE

THIS DRAWING TO BE READ IN CONJUNCTION WITH THE CONSTRUCTION MANUAL.

SIGNATURE:



Project Title / Titre du Projet  
**IRB**  
**74 VICTORIA STREET**  
 TORONTO, ON  
 Drawing Title / Titre du Dessin  
**6th FLOOR**  
**FURNITURE PLAN**  
**CATEGORY 1A & 1B**

Date: <b>15 NOV 2019</b>	Scale / Echelle <b>1:100</b>
Drawn by / Tracé par <b>AT</b>	Checked by / Vérifié par
Reference / Référence	

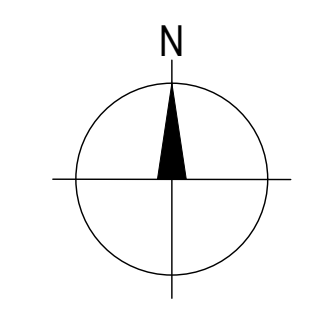

Drawing No.:  
**6-01**



- CATEGORY 1B
- 1B-01 FIXED HEIGHT WORKSURFACE, RECTANGULAR, 1 WORKSURFACE SUPPORT, FULL GABLE, LAMINATED FINISH, WORKSURFACE WITH GRIMMETS  
SURFACES DE TRAVAIL À HAUTEUR FIXE, RECTANGULAIRE, SURFACE DE TRAVAIL, 1 CÔTÉ PLEINE HAUTEUR, STRATIFIE FINI, SURFACE DE TRAVAIL AVEC OEUILLET  
610MM (24") D X 1825MM (72") L X 137MM (5 3/8") H  
QUANTITY: 83
  - 1B-03 HUTCHES, OPEN HUTCH, LAMINATED FINISH, UP/MOUNTED, SHARED WITH ADJACENT WORKSPACE  
HUCHES, HUCHES OUVERTES, STRATIFIE FINI, MONTÉ SUR SURFACE DE TRAVAIL AVEC CÔTES  
381MM (15") D X 1219MM (48") L  
QUANTITY: 39
  - 1B-04 HUTCHES, OPEN HUTCH, LAMINATED FINISH, UP/MOUNTED, SHARED WITH ADJACENT WORKSPACE  
HUCHES, HUCHES OUVERTES, STRATIFIE FINI, MONTÉ SUR SURFACE DE TRAVAIL AVEC CÔTES  
305MM (12") D X 762MM (30") L  
QUANTITY: 3
  - 1B-05 FILING AND STORAGE, PEDESTALS BOX/BOXFILE, WORKSURFACE SUPPORTING, LAMINATE FINISH, KEYED DIFFERENTIALLY  
CLASSIERS ET ARMOIRES DE RANGEMENT, CAISSONS À TIROIR/TIROIR/CLASSEUR, SUPPORT DE SURFACE DE TRAVAIL, STRATIFIE FINI, AVEC CLEF  
381MM (15") W X 610MM (24") D  
QUANTITY: 83
  - 1B-06 PRIVACY SCREENS, WORKSURFACE MOUNTED, FABRIC FINISH, PAINTED ALUMINUM FRAME, PANEL COVERED IN FABRIC HARMONIZED WITH THE FRAME, SCREENS MUST BE ABLE TO BE ADJUSTED TO DIFFERENT HEIGHTS  
CLOISON D'INTIMITÉ, MONTÉES SUR SURFACE DE TRAVAIL, EN TISSU FINI, CADRE EN ALUMINIUM PEINT, PANNÉAU RECOURVÉ DE TISSU HARMONISÉ AVEC LE CADRE, LES ÉCRANS DOIVENT POUVOIR ÊTRE AJUSTÉS À DIFFÉRENTES HAUTEURS  
1067MM (42") L X 915MM (36") H  
QUANTITY: 83

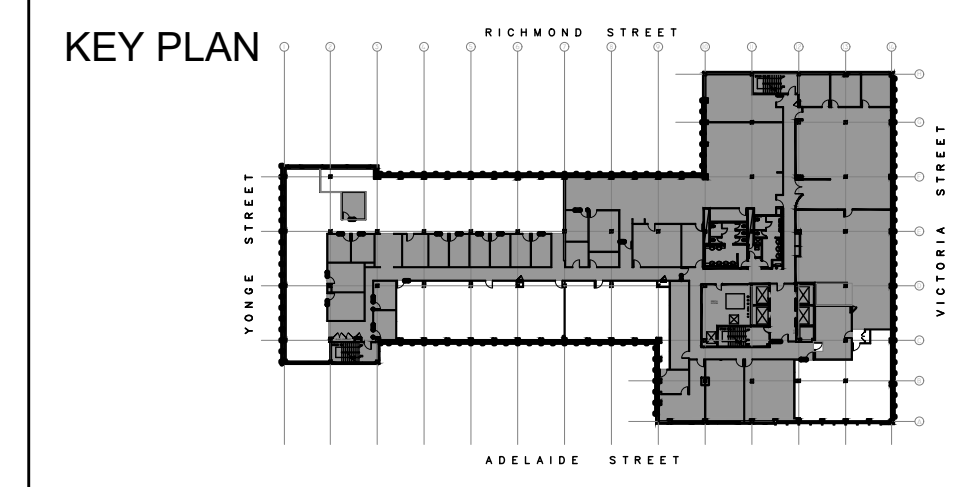

REVISION NO.	DESCRIPTION	DATE

THIS DRAWING TO BE READ IN CONJUNCTION WITH THE CONSTRUCTION MANUAL.

SIGNATURE:

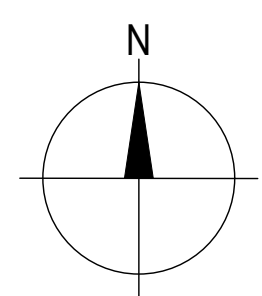

Project Title / Titre du Projet  
**IRB**  
**74 VICTORIA STREET**  
 TORONTO, ON  
 Drawing Title / Titre du Dessin  
**6th FLOOR**  
**FURNITURE PLAN**  
**CATEGORY 1A & 1B**

Date: <b>15 NOV 2019</b>	Scale / Échelle <b>1:100</b>
Drawn by / Tracé par <b>AT</b>	Checked by / Vérifié par
	Reference / Référence
	Drawing No.: <b>6-01</b>



- CATEGORY 2
- 2-01  
 INDIVIDUAL HEIGHT ADJUSTABLE WORKSURFACES, RECTANGULAR, HEIGHT ADJUSTABLE, LAMINATED FINISH, ELECTRICALLY CONTROLLED  
 SURFACES DE TRAVAIL INDIVIDUELLES À HAUTEUR RÉGLABLE, RECTANGULAIRE, RÉGLABLE EN HAUTEUR, STRATIFIÉ FINI, CONTRÔLE ÉLECTRIQUE  
 750MM (29") D X 1235MM (48") L  
 58MM (2 3/8") TO 1237MM (48 7/8") HEIGHT ADJUSTABLE  
 QUANTITY: 83
- CATEGORY 5
- 5-01  
 DUAL MONITOR ARM, CLAMP MOUNT/  
 SUPPORT D'ÉCRAN, DEUX BRAS, PINCE DE MONTAGE  
 QUANTITY: 83
- 5-02  
 POWER MODULE, WORK SURFACE MOUNTED, AC AND USB POWER  
 MODULE D'ALIMENTATION, MONTÉ SUR SURFACE DE TRAVAIL,  
 ALIMENTATION C.A. ET USB  
 QUANTITY: 83

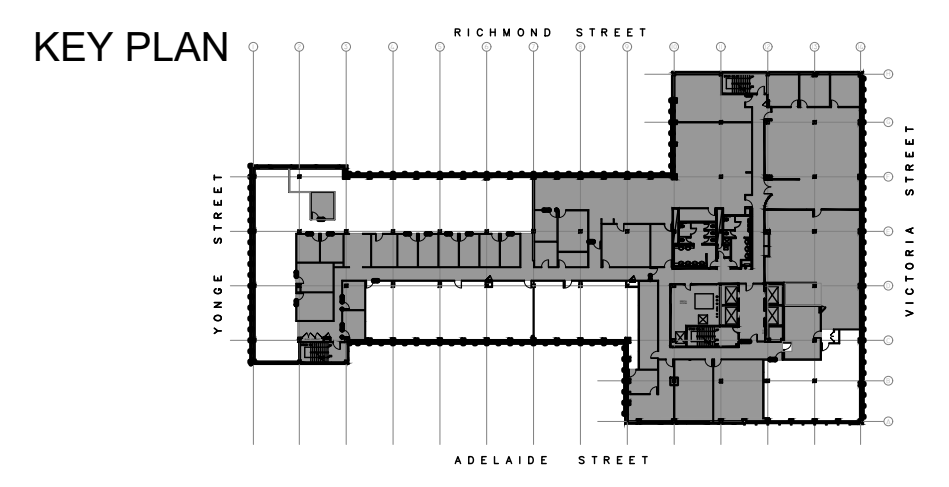

REVISION NO.	DESCRIPTION	DATE

THIS DRAWING TO BE READ IN CONJUNCTION WITH THE CONSTRUCTION MANUAL.

SIGNATURE:

Project Title / Titre du Projet  
**IRB  
 74 VICTORIA STREET**

TORONTO, ON

Drawing Title / Titre du Dessin  
**6th FLOOR  
 FURNITURE PLAN  
 CATEGORY 2 & 5**

Date: <b>15 NOV 2019</b>	Scale / Échelle <b>1:100</b>
Drawn by / Tracé par <b>AT</b>	Checked by / Vérifié par
	Reference / Référence
	Drawing No.: <b>6-02</b>

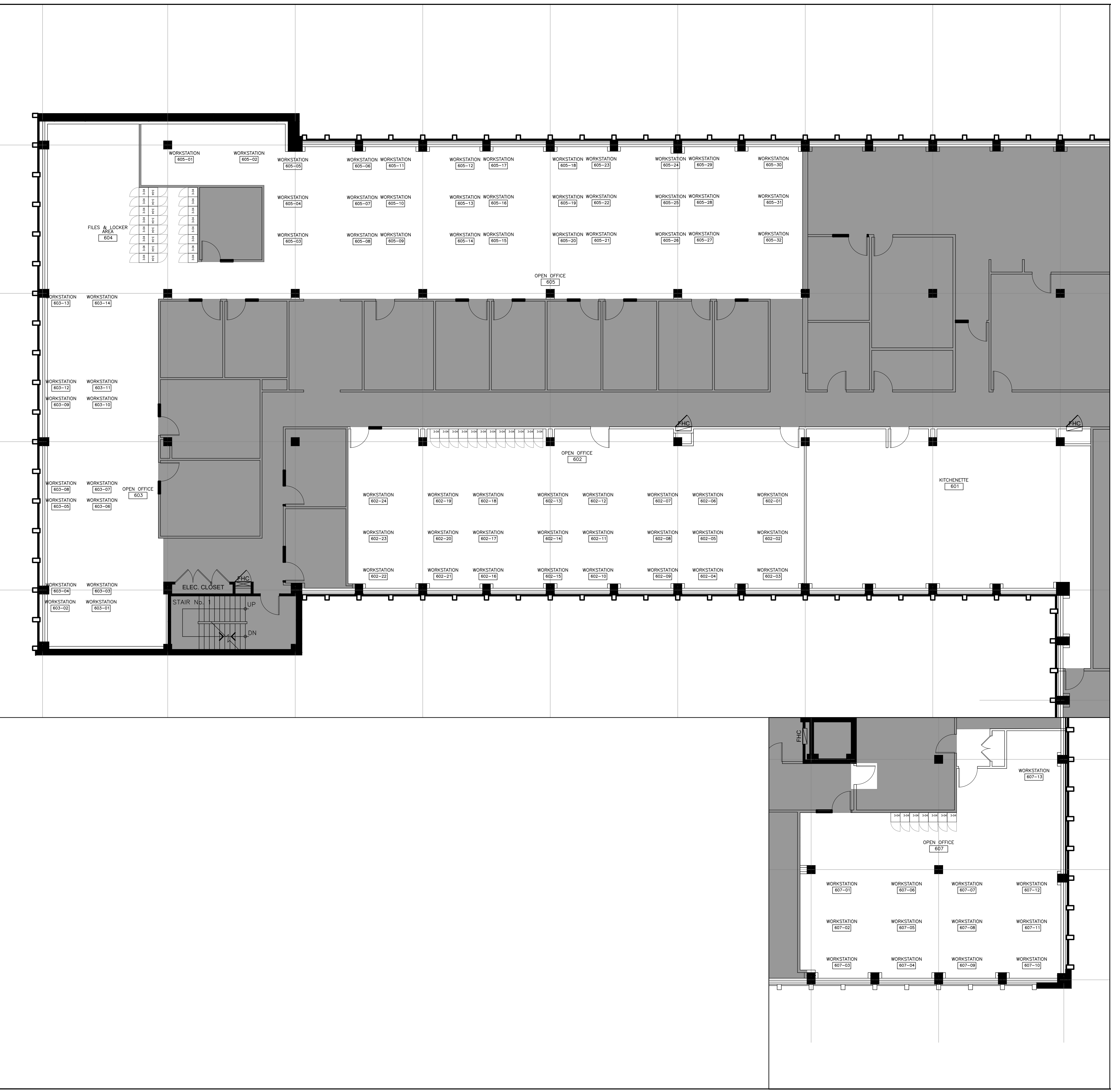

CATEGORY 3

3-04  
 STORAGE LOCKERS, TWO HIGH, METAL FINISH, ELECTRONIC KEY SYSTEM  
 CASIERS DE RANGEMENT, DEUX DE HAUT, FINITION EN MÉTAL, SYSTÈME DE CLÉ ÉLECTRONIQUE  
 457MM (18") W X 457MM (18") D 1219MM-1372MM (48"-54") H  
 QUANTITY: 43

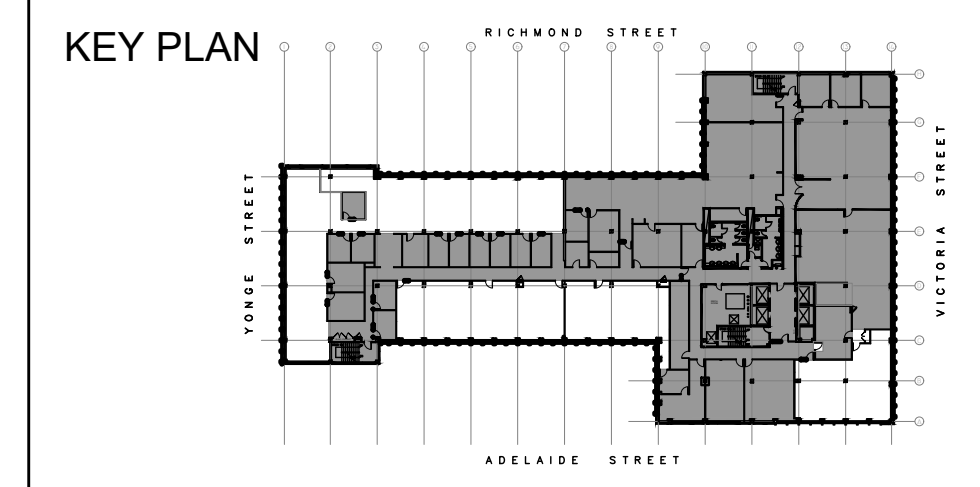

REVISION NO.	DESCRIPTION	DATE

THIS DRAWING TO BE READ IN CONJUNCTION WITH THE CONSTRUCTION MANUAL.

SIGNATURE:



Project Title / Titre du Projet  
 IRB  
 74 VICTORIA STREET  
 TORONTO, ON

Drawing Title / Titre du Dessin  
 6th FLOOR  
 FURNITURE PLAN  
 CATEGORY 3

Date: 15 NOV 2019	Scale / Echelle 1:100
Drawn by / Tracé par AT	Checked by / Vérifié par
Reference / Référence	

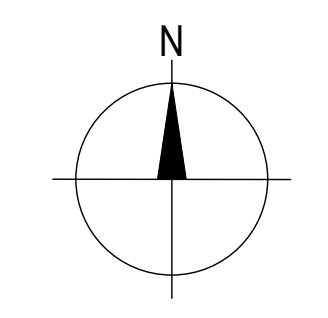

Drawing No.:  
**6-03**

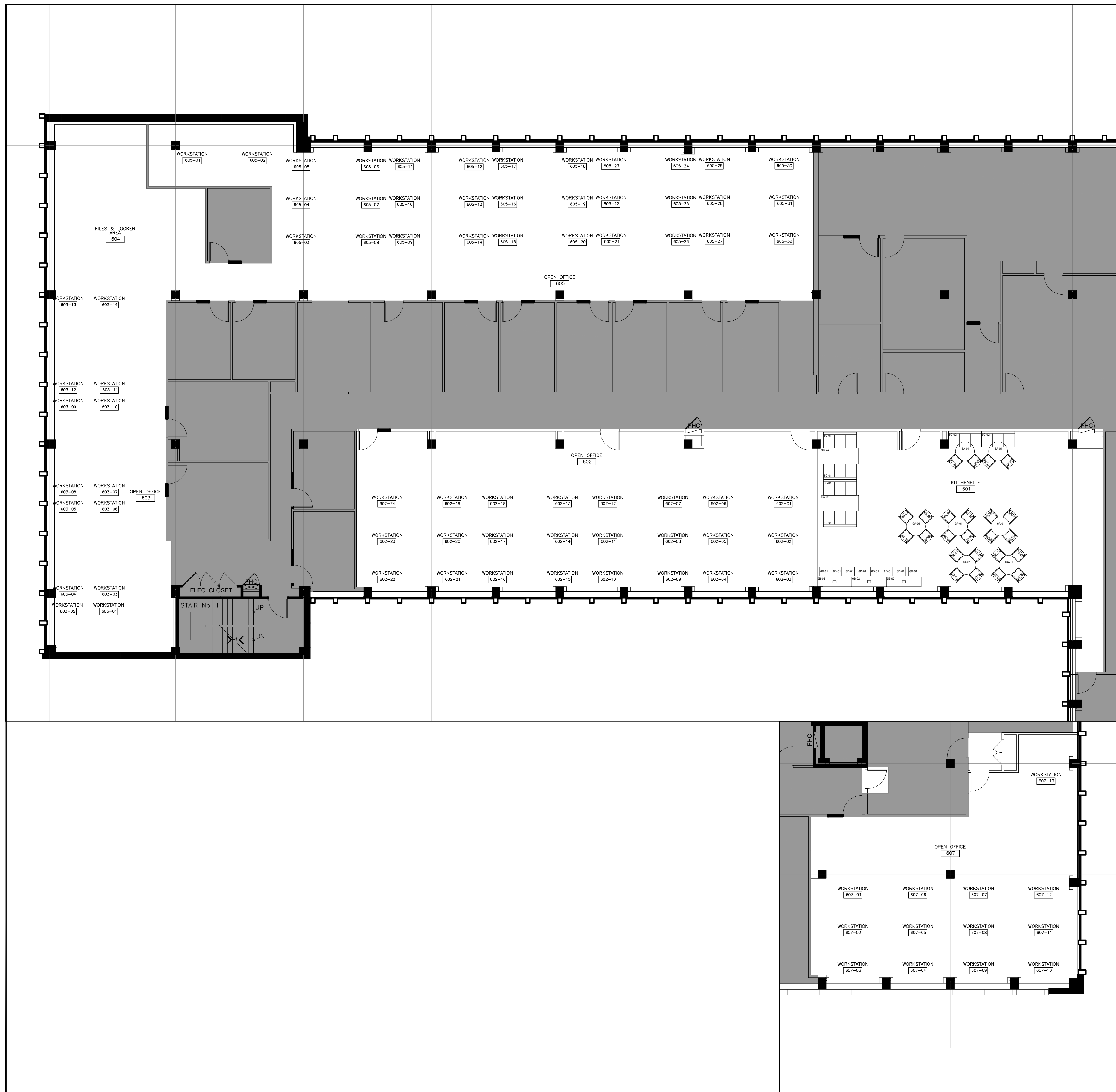

**CATEGORY 6A - MEETING TABLES & CRENDENZA**

**6A-01**  
MEETING TABLE, SMALL ROUND, PEDESTAL BASE, LAMINATE FINISH  
TABLES POUR SALLES DE RÉUNION, PETITE ROND, SOCLE SUPPORT, STRATIFIÉ FINI  
915mm (36") DIAMETER, 737mm (29") HIGH  
QUANTITY: 7

**6A-02**  
MEETING TABLE, MEDIUM RECTANGULAR, POST LEGS-COLUMN, LAMINATED FINISH, POWER IN TABLE NOT REQUIRED  
TABLES POUR SALLES DE RÉUNION, MOYEN RECTANGULAIRE, PATTES-COLONNES SUPPORT, STRATIFIÉ FINI, ALIMENTATION ÉLECTRIQUE DANS LA TABLE, NEST PAS REQUISE  
762MM (30") D X 1829MM (72") L X 737MM 29" H  
QUANTITY: 2

**CATEGORY 6B - COLLABORATIVE TABLES**

**6B-02**  
NARROW SIDE TABLES, COUNTER HEIGHT, RECTANGULAR, END GABLE SUPPORT, LAMINATED FINISH, INTEGRATED POWER/DATA  
TABLES D'APPOINT ÉTROITES, HAUTEUR COMPOT, RECTANGULAIRE, CÔTE PLEINE LARGEUR, STRATIFIÉ FINI, AVEC ALIMENTATION ÉLECTRIQUE ET DONNÉES  
303MM-421MM (12"-16") W X 1524MM-1676MM (60"-66") L X 1067MM (42"-41") H  
QUANTITY: 3

**CATEGORY 6C - COLLABORATIVE SEATING**

**6C-01**  
BANQUETTE WITH BACKREST BOLSTER THREE-SEATER, UPHOLSTERED, LEGS SUPPORT, MID BACK, WITH PRIVACY SCREEN, NO ARMREST  
BANQUETTE AVEC TRAVERSIN DE DOSSIER, TROIS PLACES, REMBOURRÉ, PATTES SUPPORT, AVEC DOSSIER, AVEC CLOISON D'INTIMITÉ, PAS ACCOUDOIRS  
1600MM-1909MM (63"-75") W X 483MM (19") D X 400MM-508MM (16"-20") H  
QUANTITY: 4

**6C-02**  
BANQUETTE WITH BACKREST BOLSTER THREE-SEATER, UPHOLSTERED, LEGS SUPPORT, MID BACK, NO ARMREST  
BANQUETTE AVEC TRAVERSIN DE DOSSIER, TROIS PLACES, REMBOURRÉ, PATTES SUPPORT, AVEC DOSSIER, PAS ACCOUDOIRS  
1600MM-1909MM (63"-75") W X 483MM (19") D X 400MM-508MM (16"-20") H  
QUANTITY: 2

**CATEGORY 6D**

**6D-01**  
BAR STOOL, BAR HEIGHT, SLED BASE, POLYMER, WITHOUT ARMREST, NO SEAT CUSHIONS  
TABOURETS DE BAR, HAUTEUR BAR, BASE TRÂNEAU, POLYMER, PAS D'ACCOUDOIRS, PAS COUSSINS DE SIÈGE  
>381MM (15") SEAT DEPTH  
711MM-813MM (28"-32") SEAT HEIGHT  
QUANTITY: 9

**6D-03**  
KITCHENETTE CHAIRS STANDARD HEIGHT, SLED BASE, POLYMER, WITHOUT ARMREST, NO SEAT CUSHIONS  
CHAISES DE CUISINETTE, HAUTEUR STANDARD, BASE TRÂNEAU, POLYMER, PAS D'ACCOUDOIRS, PAS COUSSINS DE SIÈGE  
>402MM (16") SEAT DEPTH  
432MM-508MM (17"-20") SEAT HEIGHT  
QUANTITY: 24

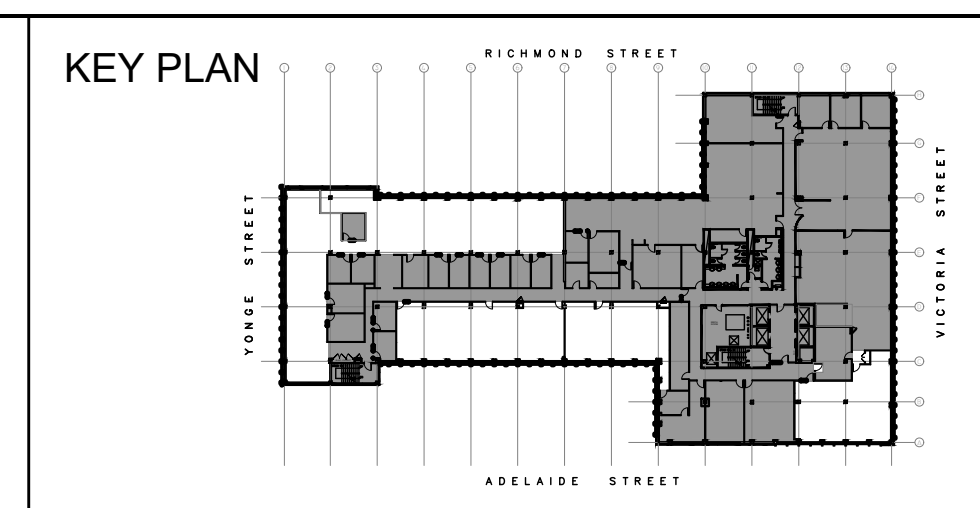

REVISION NO.	DESCRIPTION	DATE

**THIS DRAWING TO BE READ IN CONJUNCTION WITH THE CONSTRUCTION MANUAL.**

SIGNATURE:

Project Title / Titre du Projet  
**IRB  
74 VICTORIA STREET**

TORONTO, ON

Drawing Title / Titre du Dessin  
**6th FLOOR  
FURNITURE PLAN  
CATEGORY 6A 6B 6C & 6D**

Date: <b>15 NOV 2019</b>	Scale / Echelle <b>1:100</b>
Drawn by / Tracé par <b>AT</b>	Checked by / Vérifié par
	Reference / Référence
	Drawing No.: <b>6-04</b>

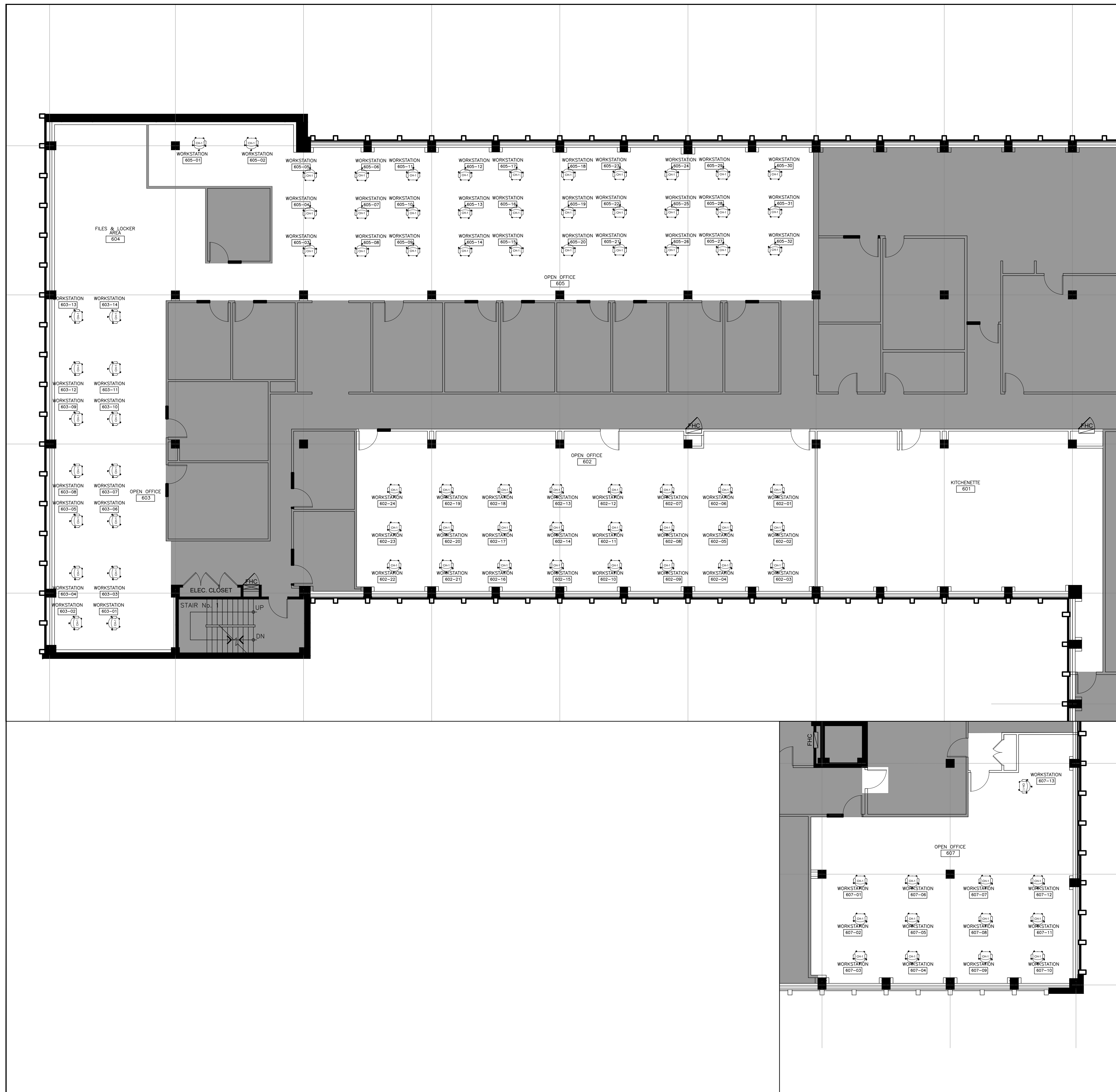

CH-1  
 ROTARY CHAIR/ FAUTEUIL DE BUREAU PILOTTANT  
 NO HEADREST, STANDARD BACK  
 ADJUSTABLE LUMBAR SUPPORT AND SEAT DEPTH  
 T ARM ARMRESTS, ADJUSTABLE HEIGHT/WIDTH/WHEEL  
 SEAT AND BACKREST LOCKABLE OR STOPPABLE IN MULTIPLE POSITIONS  
 TILT MECHANISM INDEPENDENTLY  
 UPHOLSTERY: BACK BREATHABLE MATERIAL/SEAT FABRIC  
 AUCUN APPUI-TÊTE, HAUTEUR DE DOSSIER STANDARD  
 SUPPORT LOMBAIRE AJUSTABLE  
 ACCOUDEURS: ACCOUDEURS EN "T" AJUSTABLES EN HAUTEUR, LARGEUR ET EN INCLINAISON  
 PROFONDEUR DE SIÈGE: RÉGLABLE  
 VERROUILLAGES DU SIÈGE ET DU DOSSIER: VERROUILLABLE OU BLOQUABLE EN PLUSIEURS POSITIONS  
 MÉCANISME D'INCLINAISON INDEPENDANTMENT  
 REMBOURRAG: REVÊTEMENT DU DOSSIER EN TISSU RESPIRANT/TISSU DU SIÈGE  
 QUANTITY: 85

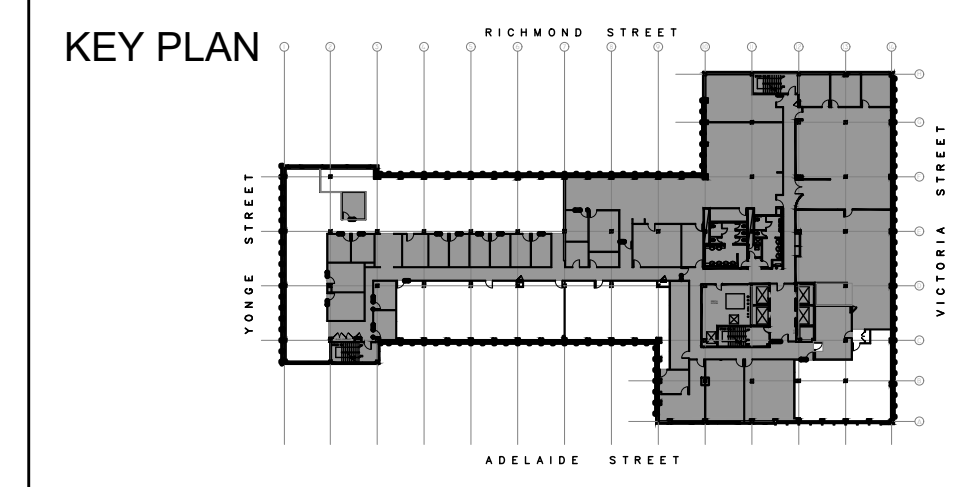

REVISION NO.	DESCRIPTION	DATE

THIS DRAWING TO BE READ IN CONJUNCTION WITH THE CONSTRUCTION MANUAL.

SIGNATURE:

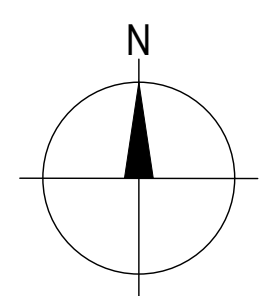

Project Title / Titre du Projet  
**IRB**  
**74 VICTORIA STREET**  
 TORONTO, ON  
 Drawing Title / Titre du Dessin  
**6th FLOOR**  
**FURNITURE PLAN**  
**CHAIRS**

Date: <b>15 NOV 2019</b>	Scale / Echelle <b>1:100</b>
Drawn by / Tracé par <b>AT</b>	Checked by / Vérifié par
	Reference / Référence
	Drawing No.: <b>6-05</b>





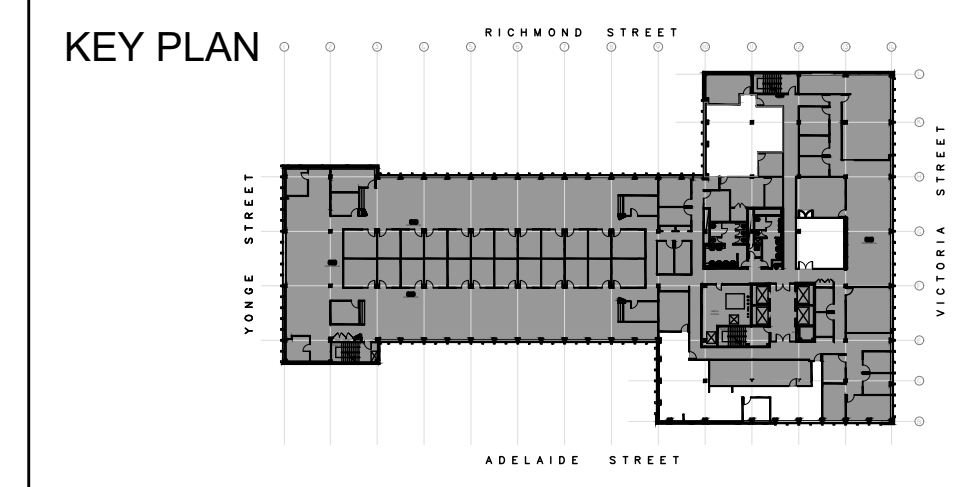

REVISION NO.	DESCRIPTION	DATE

THIS DRAWING TO BE READ IN CONJUNCTION WITH THE CONSTRUCTION MANUAL.

SIGNATURE:



Project Title / Titre du Projet

IRB  
74 VICTORIA STREET

TORONTO, ON

Drawing Title / Titre du Dessin

8th FLOOR  
FURNITURE PLAN  
CATEGORY 1A & 1B

Date: 15 NOV 2019	Scale / Echelle 1:100
Drawn by / Tracé par AT	Checked by / Vérifié par

	Reference / Référence
	Drawing No.: <b>8-01</b>

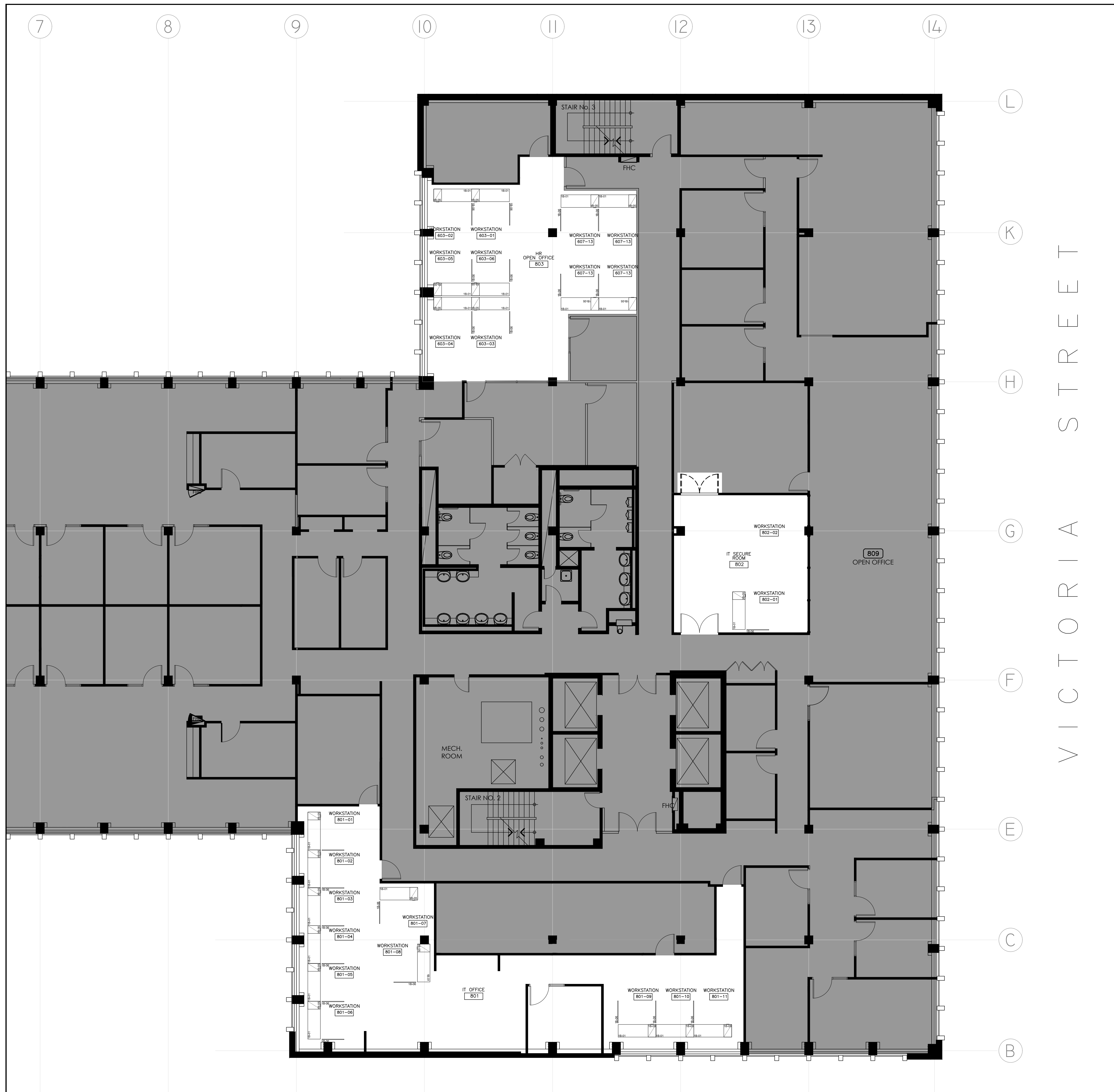

VICTORIA STREET

CATEGORY 1B

1B-01	1B-01 FIXED HEIGHT WORKSURFACE, RECTANGULAR, 1 WORKSURFACE SUPPORT, FULL GABLE, LAMINATED FINISH, WORKSURFACE WITH GRIMMETS SURFACES DE TRAVAIL À HAUTEUR FIXE, RECTANGULAIRE, SURFACE DE TRAVAIL À CÔTÉ PLEINE HAUTEUR, STRATIFIÉ FINI, SURFACE DE TRAVAIL AVEC OUELLET 610MM (24") D X 1825MM (72") L X 137MM (5 3/8") H QUANTITY: 22
1B-05	1B-05 FILING AND STORAGE, PEDESTALS BROW/BONFILE, WORKSURFACE SUPPORTING LAMINATE FINISH, KEYED DIFFERENTLY CLASSEURS ET ARMOIRES DE RANGEMENT, CAISSONS À TROU/TROUS/CLASSEUR, SUPPORT DE SURFACE DE TRAVAIL, STRATIFIÉ FINI, AVEC CLEF 381MM (15") W X 610MM (24") D QUANTITY: 22
1B-06	1B-06 1B-06 PRIVACY SCREENS, WORKSURFACE MOUNTED, FABRIC FINISH, PAINTED ALUMINUM FRAME, PANEL COVERED IN FABRIC HARMONIZED WITH THE FRAME, SCREENS MUST BE ABLE TO BE ADJUSTED TO DIFFERENT HEIGHTS CLOISON D'INTIMITÉ, MONTÉES SUR SURFACE DE TRAVAIL, EN TISSU FINI, CADRE EN ALUMINIUM PEINT, PANNEAU RECOUVERT DE TISSU HARMONISÉ AVEC LE CADRE, LES ÉCRANS DOIVENT POUVOIR ÊTRE AJUSTÉS À DIFFÉRENTES HAUTEURS 197MM (42") L X 915MM (36") H QUANTITY: 22

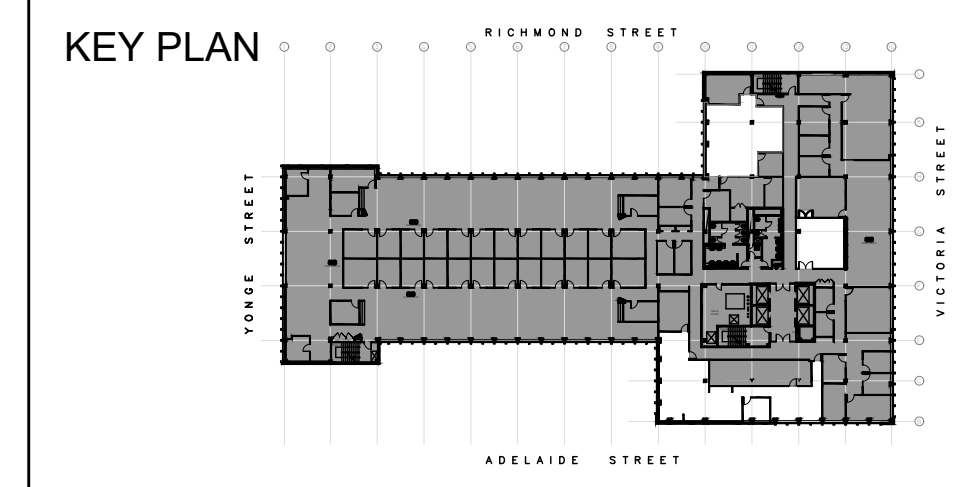

REVISION NO.	DESCRIPTION	DATE

THIS DRAWING TO BE READ IN CONJUNCTION WITH THE CONSTRUCTION MANUAL.

SIGNATURE:



Project Title / Titre du Projet  
**IRB**  
**74 VICTORIA STREET**

TORONTO, ON

Drawing Title / Titre du Dessin  
**8th FLOOR**  
**FURNITURE PLAN**  
**CATEGORY 1A & 1B**

Date: <b>15 NOV 2019</b>	Scale / Echelle <b>1:100</b>
Drawn by / Tracé par <b>AT</b>	Checked by / Vérifié par
	Reference / Référence
	Drawing No.: <b>8-01</b>



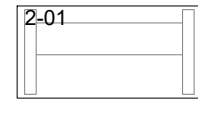

VICTORIA STREET

**CATEGORY 2**

2-01  
  
 2-01 INDIVIDUAL HEIGHT ADJUSTABLE WORKSURFACES, RECTANGULAR, HEIGHT ADJUSTABLE, LAMINATED FINISH, ELECTRICALLY CONTROLLED. SURFACES DE TRAVAIL INDIVIDUELLES A HAUTEUR REGLABLE, RECTANGULAIRE, REGLABLE EN HAUTEUR, STRATIFIE FINI, CONTROLÉ ELECTRIQUEMENT. 750MM (30") D X 1219MM (48") L, 864MM (33") TO 1237MM (48.7") HEIGHT ADJUSTABLE. QUANTITY: 22

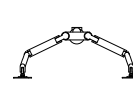
**CATEGORY 5**

5-01  
  
 5-01 DUAL MONITOR ARM, CLAMP MOUNT/ SUPPORT D'ECRAN, DEUX BRAS, PINCE DE MONTAGE. QUANTITY: 22

5-02  
  
 5-02 POWER MODULE, WORK SURFACE MOUNTED, AC AND USB POWER MODULE D'ALIMENTATION, MONTÉ SUR SURFACE DE TRAVAIL, ALIMENTATION C.A. ET USB. QUANTITY: 22

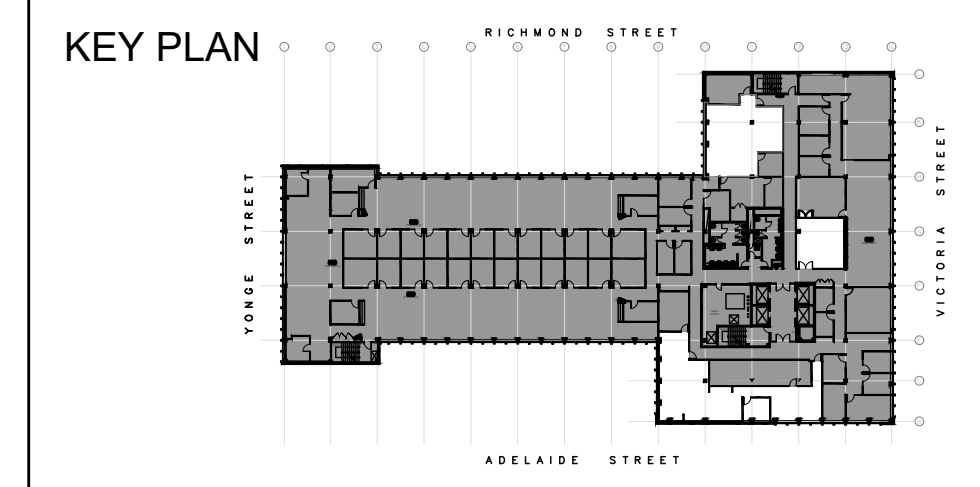

REVISION NO.	DESCRIPTION	DATE

THIS DRAWING TO BE READ IN CONJUNCTION WITH THE CONSTRUCTION MANUAL.

SIGNATURE:



Project Title / Titre du Projet  
 IRB  
 74 VICTORIA STREET  
 TORONTO, ON

Drawing Title / Titre du Dessin  
 8th FLOOR  
 FURNITURE PLAN  
 CATEGORY 2 & 5

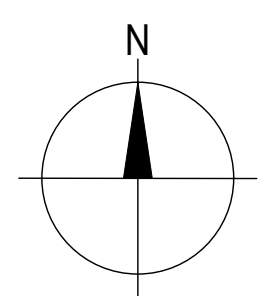
Date: 15 NOV 2019	Scale / Echelle 1:100
Drawn by / Tracé par AT	Checked by / Vérifié par
	Reference / Référence
	Drawing No.: 8-02















