

NOTE: 1. DO NOT SCALE THIS PRINT  
 2. BREAK SHARP CORNERS  
 3. TOLERANCE ON DIMENSIONS NOT OTHERWISE SPECIFIED  
 DECIMAL FRACTIONAL ± .002  
 ANGULAR

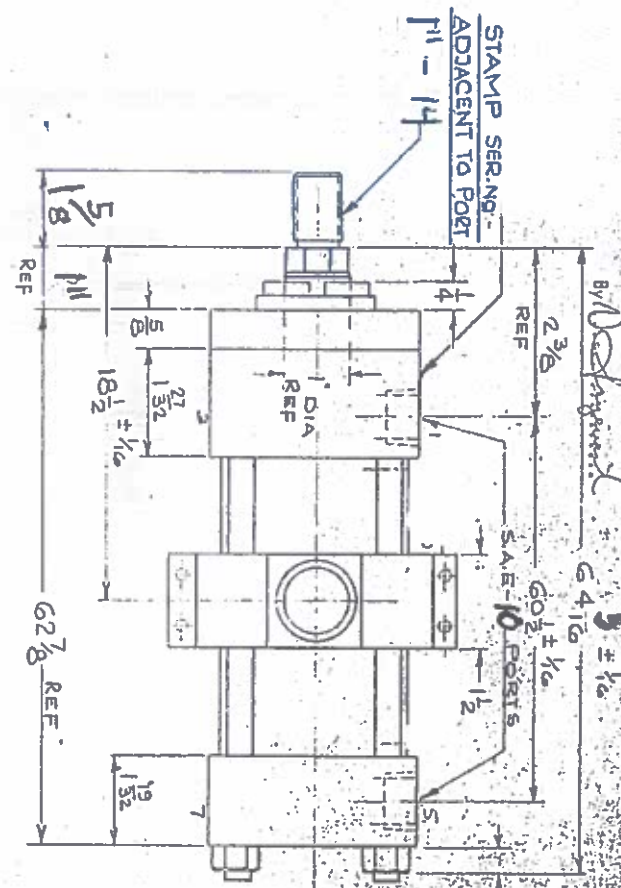
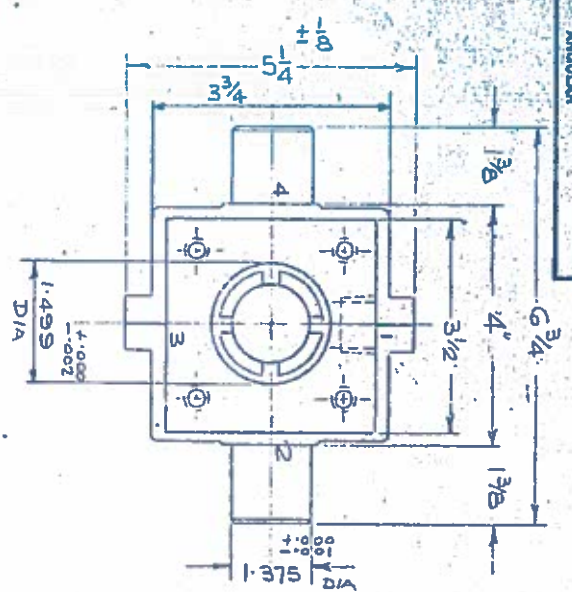

CERTIFIED  
 DEC 12 1978  
 correct for dimensions

NOTE: CHEVRON PISTON PACKING

Vicroy Fluid Power Ltd  
 By *DeGyver*

CUSTOMER: V.F.P.L. NO. 26575  
 MODEL NO. 2 1/2 TH EST 1/2 CCAKY BORE: 2 1/2 STROKE: 5 1/4 ROD: 1 3/8  
 PRESSURE: 2500 PSI TEMP 200°F MAX MEDIUM HYD-OIL  
 PORTS: 1 & 5 ADJUSTING SCR 3&7 BALL CHECK 3&7

VER. L. NO. 26575  
 CUST NO. 4915-9-G1179  
 "DOUBLE SLING"  
 VICEROY CYLINDER  
 2TH SERIES  
 2 1/2 - BORE  
 OR. BY A.G. ORN ST. 14

DEC 12 1978  
 VICEROY FLUID POWER LIMITED  
 REMOVAL ORTARIO CANNON

ROD: STAINLESS STL CHROME-PLATED

2	TAPR7B	AS BUILT	DESCRIPTION	DATE	BY	SCALE
1	APR 77	CERTIFIED FOR MANUFACTURE		MAY 11 1977	A.G.	N.T.S.
						5