



Procurement and Contracting Services  
30 Victoria Street  
Gatineau, Quebec K1A 0M6

## REQUEST FOR PROPOSAL AMENDMENT

The Request for Proposal is hereby amended; unless otherwise indicated, all other terms and conditions of the Request for Proposal remain the same.

<b>RFP Amendment No.</b>  2	<b>RFP Amendment Date:</b>  April 7, 2020
<b>Office of the Chief Electoral Officer File No.</b>  ECLP-RFP-19-0819	
<b>Title:</b>  EC10391 – Carbonless Paper (2 part – white/yellow Letter Format) and EC10396 – Carbonless Paper (3 part – white/yellow/ pink Legal Format)	
<b>Request for Proposal Closing Date:</b>  April 28, 2020 at 2:00 p.m. (Gatineau time)	
<b>ENQUIRIES – address enquiries to the Contracting Authority:</b>  <b>Office of the Chief Electoral Officer of Canada</b> Procurement and Contracting Services 30 Victoria Street Gatineau, Quebec K1A 0M6	
<b>Attention:</b>  Luc Potvin	<b>Email:</b>  proposition-proposal@elections.ca

## **Part 1. Interpretation**

- 1.1** Elections Canada hereby amends in accordance with this amendment the Request for Proposal bearing number ECLP-RFP-19-0819 and dated March 12, 2020 (the “RFP”). This amendment hereby forms part of the RFP.
- 1.2** Unless defined herein or unless the context otherwise requires, all of the words and phrases defined in the RFP and used in this amendment shall have the same meanings assigned to them in the RFP.

## **Part 2. Questions and Answers**

The following question(s) have been asked in response to the Request for Proposal and Elections Canada hereby answers as follows:

### **2.1 Question No. 3**

Question:

Would you please let us know if the required NCR paper is Blue Print image or Black Print image?

Answer:

The NCR paper requires a black print reproduction.

### **2.2 Question No. 4**

Question:

Is that possible to extend the delivery date from **July 31, 2020** to **August 31, 2020**? Due to exceptional situation of COVID-19, there are lots of global shipping/transportation issues.

Answer:

Due to circumstances, the delivery date is extended to **August 28, 2020**.

## **Part 3. Amendments**

### **3.1 Amendment to Annex A – Statement of Work of the Request for Proposal**

The Request for Proposal is hereby amended by deleting in its entirety **Annex A – Statement of Work** and replacing it with the attached **Annex A – Statement of Work** (Revised April 7, 2020).



**EC10391 – Carbonless Paper (2 part – white/yellow letter format)**  
**EC10396 – Carbonless Paper (3 part – white/yellow/pink legal format)**

---

**ANNEX A**

**Statement of Work**

**Revised April 7, 2020**

**Item 1**

<b>DESCRIPTION OF DELIVERABLE:</b>	To supply standard 2-part reverse carbonless paper (NCR), letter size, pre-collated; canary, white. Supplier must wrap 250 sets of 2 (500 sheets) with a commercial wrapping and 2 labels.
<b>REFERENCE NUMBER AND TITLE:</b>	<b>EC 10391 (05/2019)</b> 2-Part Reverse Carbonless Paper (white/yellow), Letter Size
<b>QUANTITY:</b>	650 packages of 500 sheets (250 sets of 2)
<b>OVER:</b>	<b><i>No over / No under</i></b> Elections Canada will not pay an invoice for items received in excess of the quantity stipulated in this specification, nor will it pay the full amount when items are sent in lower quantities than requested. It is the supplier's responsibility to ensure that items are shipped in the correct quantities.
<b>PARTS:</b>	2-Part Pre-collated Reverse Carbonless Paper (NCR) <ul style="list-style-type: none"><li>- CF (Coated Front) Canary</li><li>- CB (Coated Back) White</li></ul>
<b>STOCK:</b>	Carbonless Reverse Paper (NCR) – Pre-collated <ul style="list-style-type: none"><li>- Reverse sequence</li><li>- Black impression</li><li>- No printing required</li></ul>
<b>PAPER WEIGHT:</b>	21 lbs / 80 GSM
<b>SIZE:</b>	Letter size - 8.5" x 11"

**IMAGE:**



**WRAPPING:**

Supplier must wrap 500 sheets (250 sets of 2) per package/ream using a commercial wrapping and must affix two labels on each package:

- 1) a label on one end indicating the content as well as the instruction for the paper placement in the printer;
- 2) a label on the top of the ream with the following EC information:

**EC information labels:**

Clearly identify each package in a minimum 20 pt type size as follows:

<p style="text-align: center;"><b><i>EC 10391 (05/2019)</i></b> <i>NCR paper for Oaths - 8.5" x 11"</i> <i>Papier autocopiant pour Serments - 8.5" x 11</i> <i>Qty/Qté – 500 sheets/250 sets of 2</i></p>
---

**NOTE:** Labeling of items going to the Distribution Centre must be exactly as indicated. If not, they will not be accepted.

**See APPENDIX A for a sample of a commercial wrapping with both labels.**

**PROOF:**

The supplier must provide a sample of the carbonless paper for sign-off prior to production.

An electronic proof showing the labels in position as shown in Appendix A must also be sent to the Elections Canada Project Authority for sign-off prior to production.

**PACKAGING:**

Put 6 packages/reams together in corrugated boxes. Each box must be identically packaged and completely filled, i.e. they must all have the same number of packages. Each box not to weigh more than 35 lbs. Clearly identify each box as to content in a minimum 20 pt type size.

**IMPORTANT: This order contains 650 packages/reams representing 108 boxes of 6 reams and one box of 2 reams. Ensure that the box containing only 2 reams is correctly labelled as to its content.**

**Packaging label on boxes:**

<p><b>EC 10391 (05/2019)</b> <i>NCR paper for Oaths - 8.5" x 11"</i> <i>Papier autocopiant pour Serments - 8.5" x 11"</i> <i>Qty / Qté – XX packages of 500 sheets/250 sets of 2</i></p>
--

**NOTE:** Labeling of items going to the Distribution Centre must be exactly as indicated. If not, they will not be accepted.

**MANDATORY DELIVERY DATE:**

On or before, but no later than **August 28, 2020**

Provided prior approval by the Project Authority, partial deliveries will be accepted but entire production must be delivered by **August 28, 2020**.

**SHIPPING:**

Ship on non-returnable shipping skids 48" wide by 42" deep not to exceed 54" high stacking height. The material must be accessible by hand held hydraulic pallet movers.

**SKIDS:**

Brewery type skid – 4 way entry type, 48" wide by 42" deep, 3 stringers with three blocks, each running 48" long.

**NOTE:** Items shipped to the Distribution Centre not on requested skids **WILL NOT BE ACCEPTED** upon delivery.

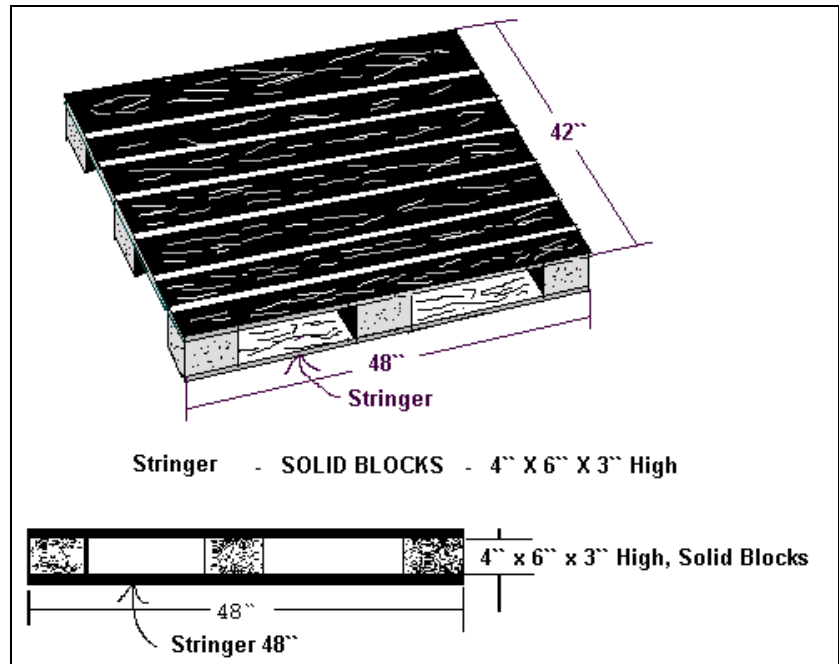
**HOURS OF OPERATION:**  
(Ottawa time)

8 a.m. to 12:00 noon / 1:00 p.m. to 4:00 p.m.

**DESTINATION:**Elections Canada Distribution Centre  
100-440 Coventry Road  
Ottawa (ON) K1K 2Y5**INVOICE:**

Please send your invoice to the following address:

Fawn-Dell Flanagan  
Material Management, OFG  
Elections Canada  
30 Victoria Street  
Gatineau (QC) K1A 0M6

Or by e-mail:

[gestiondumatérielSGF-materialmanagementSMS@elections.ca](mailto:gestiondumatérielSGF-materialmanagementSMS@elections.ca)

It is the responsibility of the supplier to provide a valid tax registration number for: HST, GST and QST, as applicable. Elections Canada will not validate tax registration numbers. If applicable taxes are invoiced without a tax registration number(s), Elections Canada will not pay the applicable tax(es).

Invoices must indicate the Purchase Order number, if applicable, the Reference Number, the revision date and show any correction cost breakdown whenever it is applicable.

**ADDITIONAL INFORMATION:**

No change in these specifications will be accepted unless approved by the project authority.

Elections Canada must be informed of the cost of any author's alterations as soon as possible. A contract amendment must be made as soon as any changes affecting cost occur.

Wrapping and shipping instructions must be followed to the letter or the Distribution Centre may refuse to accept the shipment.



**Appendix A**

Sample of a commercial wrapping with the two labels

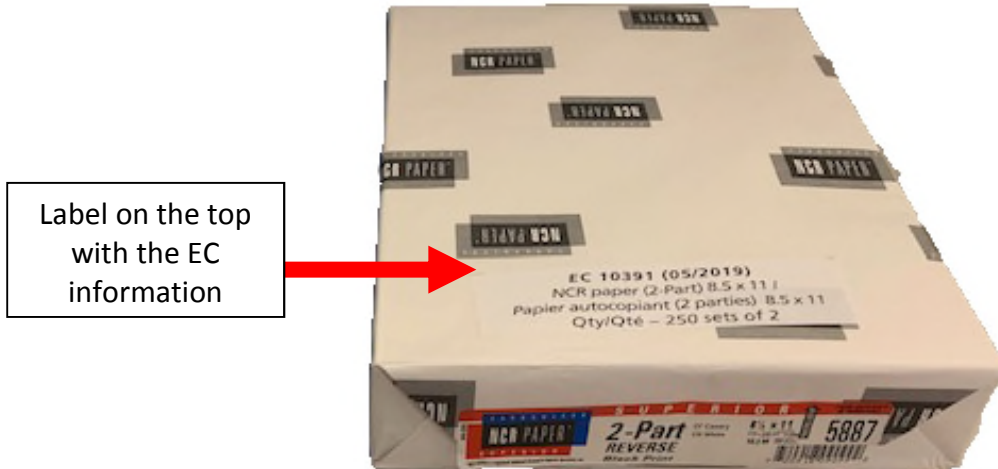

Label on the top  
with the EC  
information



Label on one end indicating the  
content as well as the instruction  
for the paper placement in the  
printer

**Item 2**

<b>DESCRIPTION OF DELIVERABLE:</b>	To supply 3-part reverse digital carbonless paper (NCR), legal size, pre-collated; pink, canary, white. Supplier must wrap 167 sets of 3 (501 sheets) with a commercial wrapping and 2 labels. Then, the supplier must insert 3 packages of 501 sheets (167 sets of 3) into a box, for a total of 350 boxes.
<b>REFERENCE NUMBER AND TITLE:</b>	<b>EC 10396 (01/2020)</b> 3-Part Reverse Digital Carbonless Paper (white/yellow/pink), Legal Size
<b>QUANTITY:</b>	1,050 packages of 501 sheets (167 sets of 3) - 3 packages per box for a total of 350 boxes
<b>OVER:</b>	<b><i>No over / No under</i></b> Elections Canada will not pay an invoice for items received in excess of the quantity stipulated in this specification, nor will it pay the full amount when items are sent in lower quantities than requested. It is the supplier's responsibility to ensure that items are shipped in the correct quantities.
<b>PARTS:</b>	3-Part Reverse Carbonless Paper (NCR) - CF (Coated Front) Pink - CFB (Coated Front and Back) Canary - CB (Coated Back) White
<b>STOCK:</b>	Digital Carbonless Paper (NCR) – Pre-collated - Reverse sequence - Black impression (dye capsules color) - No printing required.
<b>PAPER WEIGHT:</b>	21 lbs / 80 GSM
<b>FORMAT:</b>	Legal size – 8.5" x 14"

**IMAGE:****WRAPPING:**

Supplier must wrap 501 sheets (167 sets of 3) per package using a commercial wrapping and must affix two labels on each package:

- 1) a label on one end indicating the content as well as the instruction for the paper placement in a laser printer or photocopier;
- 2) a label on the top with the following EC information:

**EC information wrapping labels:**

Clearly identify each package in a minimum 20 pt type size as follows:

<p style="text-align: center;"><b><i>EC 10396 (01/2020)</i></b> <i>NCR paper for Statement of the Vote – 8.5" x 14"</i> <i>Papier autocopiant pour Relevé du scrutin – 8.5" x 14"</i> <i>Qty/Qté – 501 sheets/167 sets of 3</i></p>
---

**NOTE:** Labeling of items going to the Distribution Centre must be exactly as indicated. If not, they will not be accepted.

**See APPENDIX B for a sample of a commercial wrapping with the two labels.**

**PROOF:**

The supplier must provide a sample of the carbonless paper for sign-off prior to production.

An electronic proof showing the labels in position as shown in Appendix A must also be sent to the Elections Canada Project Authority for sign-off prior to production.

**PACKAGING:**

It is mandatory to have **3 packages of 501 sheets per box** to meet Elections Canada's distribution criteria across Canada.

Insert 3 packages per corrugated box. Clearly identify each box as to content in a minimum 20 pt type size.

**Packaging label on boxes:**

**EC 10396 (01/2020)**  
*NCR paper for Statement of the Vote – 8.5"x14"*  
*Papier autocopiant pour Relevé du scrutin – 8.5"x14"*  
*Qty / Qté – 3 packages (total 501 sets of 3)*

**NOTE:** Labelling of items going to the Distribution Centre must be exactly as indicated. If not, they will not be accepted.

**MANDATORY DELIVERY DATE:**

**On or before, but no later than August 28, 2020**

Provided prior approval by the Project Authority, partial deliveries will be accepted but entire production must be delivered by **August 28, 2020**.

**SHIPPING INSTRUCTIONS:**

Ship on non-returnable shipping skids 48" wide by 42" deep not to exceed 54" high stacking height. The material must be accessible by hand-held hydraulic pallet movers.

**SKIDS:**

Brewery type skid – 4 way entry type, 48" wide by 42" deep, 3 stringers with three blocks, each running 48" long

**NOTE:** Items shipped to the Distribution Centre not on requested skids **WILL NOT BE ACCEPTED** upon delivery.

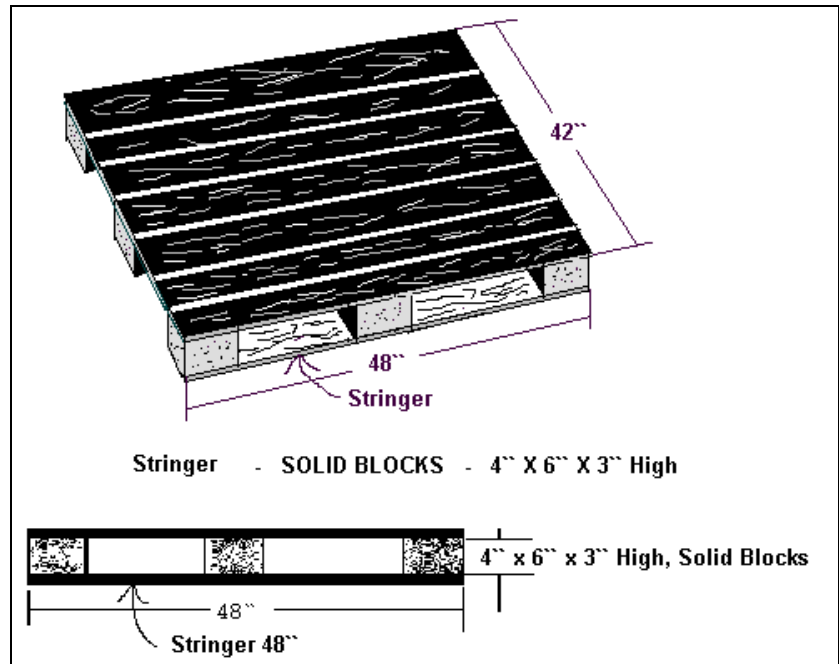
**HOURS OF OPERATION:  
(OTTAWA TIME)**

8 a.m. to 12:00 noon / 1:00 p.m. to 4:00 p.m.

**DESTINATION:**Elections Canada Distribution Centre  
100-440 Coventry Road, Ottawa, Ontario K1K 2Y5**INVOICE:**

Please send your invoice to the following address:

Fawn-Dell Flanagan  
Material Management, OFG  
Elections Canada  
30 Victoria Street  
Gatineau (QC) K1A 0M6

Or by e-mail:

[gestiondumatérielSGF-materialmanagementSMS@elections.ca](mailto:gestiondumatérielSGF-materialmanagementSMS@elections.ca)

It is the responsibility of the supplier to provide a valid tax registration number for: HST, GST and QST, as applicable. Elections Canada will not validate tax registration numbers. If applicable taxes are invoiced without a tax registration number(s), Elections Canada will not pay the applicable tax(es).

Invoices must indicate the Purchase Order number, if applicable, the Reference Number, the revision date and show any correction cost breakdown whenever it is applicable.

**ADDITIONAL INFORMATION:**

No change in these specifications will be accepted unless approved by the project authority.

Elections Canada must be informed of the cost of any author's alterations as soon as possible. A contract amendment must be made as soon as any changes affecting cost occur.

Wrapping and shipping instructions must be followed to the letter or the Distribution Centre may refuse to accept the shipment.

## Appendix B

Sample of a commercial wrapping with the two labels

