



Procurement and Contracting Services
30 Victoria Street
Gatineau, Quebec K1A 0M6

REQUEST FOR PROPOSAL AMENDMENT

The Request for Proposal is hereby amended; unless otherwise indicated, all other terms and conditions of the Request for Proposal remain the same.

RFP Amendment No. 2	RFP Amendment Date: April 15, 2020
Office of the Chief Electoral Officer File No. ECLP-RFP-19-0829	
Title: EC10930 – Box for the Return of Election Material and EC40190 – Box for the Revision Form	
Request for Proposal Closing Date: May 20, 2020 at 1:00 p.m. (Gatineau time)	
ENQUIRIES – address enquiries to the Contracting Authority: Office of the Chief Electoral Officer of Canada Procurement and Contracting Services 30 Victoria Street Gatineau, Quebec K1A 0M6 proposition-proposal@elections.ca	
Attention: Luc Potvin	Email: proposition-proposal@elections.ca

Part 1. Interpretation

- 1.1** Elections Canada hereby amends in accordance with this amendment the Request for Proposal bearing number ECLP-RFP-19-0829 and dated March 17, 2020 (the “RFP”). This amendment hereby forms part of the RFP.
- 1.2** Unless defined herein or unless the context otherwise requires, all of the words and phrases defined in the RFP and used in this amendment shall have the same meanings assigned to them in the RFP.

Part 2. Questions and Answers

The following question(s) have been asked in response to the Request for Proposal and Elections Canada hereby answers as follows:

2.1 Question No. 6

Question:

Is that possible to extend the delivery from July 6, 2020 to August 31, 2020? Due to exceptional circumstances of COVID-19, there are lots of global shipping/transportation issues.

Answer:

The delivery date has been extended to August 28, 2020.

Part 3. Amendments

3.1 Amendment to the closing date of the Request for Proposal

The Request for Proposal is hereby amended as follows:

On Page 1 of the RFP:

(A) Request for Proposal Closing Date:

Delete: April 29, 2020 at 2:00 p.m. (Gatineau time)

Insert: **May 20, 2020 at 1:00 p.m.** (Gatineau time)

(B) Elections Canada Proposal Receiving Unit:

New Temporary Business Hours:

Tuesday, Wednesday and Thursday from 9:00 a.m. to 1:00 p.m. only.

3.2 Amendment to Annex A – Statement of Work of the Request for Proposal

The Request for Proposal is hereby amended by deleting in its entirety **Annex A – Statement of Work** and replacing it with the attached **Annex A – Statement of Work** (Revised April 15, 2020).



EC 10930 – Box for the Return of Election Material
EC 40190 – Box for the Revision Form

ANNEX A

Statement of Work

Revised April 15, 2020

Item 1 – EC 10930**1.1 DESCRIPTION OF DELIVERABLE:** Corrugated Fiberboard Box glued inside**1.2 REFERENCE NUMBER:** **EC 10930 (03/2020)****1.3 TITLE:** Box for the return of election material**1.4 QUANTITY:** 70,000 boxes**1.5 OVER:** ***No over / No under***

Elections Canada will not pay an invoice for items received in excess of the quantity stipulated in this specification, nor will it pay the full amount when items are sent in lower quantities than requested. It is the supplier's responsibility to ensure that items are shipped in the correct quantities.

1.6 SIZE: **OUTSIDE:** 19.5" x 11.5" x 9"**INSIDE:** 19 1/8" x 11 1/8" x 8 3/8"**1.7 PRINTING:** Elections Canada Logo and text to be printed on 19.25" panel one side. A high-resolution PDF file provided.

	ED/CIRC. # _____		
<table border="1"> <tr> <td style="text-align: center;">LOT # _____</td> </tr> <tr> <td style="text-align: center;">BOX/BOÎTE _____ OF/DE _____</td> </tr> </table>		LOT # _____	BOX/BOÎTE _____ OF/DE _____
LOT # _____			
BOX/BOÎTE _____ OF/DE _____			

The supplier must print the Elections Canada identification number "EC 10930 (03/2020)" on both 11.25" side panels and on bottom panel.

1.8 INK: Black, no bleed

1.9 STOCK:

- Kraft, regular slotted container (RSC), corrugated fibreboard
- 32 lbs ECT, C-flute, single wall

1.10 COMPONENT:

A high-resolution PDF of the EC logo and text supplied.

Cutting die for the box is not available; it is the supplier's responsibility to produce the die.

A sample of a similar box is available upon request.

See **Appendix A** for a diagram of the box.

1.11 PROOF:

A prototype of the box showing the EC logo and text in position is required for approval before production.

Please send to Elections Canada, Distribution Center, 100-440 Coventry Road, Ottawa, Ontario, K1K 2Y5.

Attention: **Project Authority**

1.12 IMAGE:

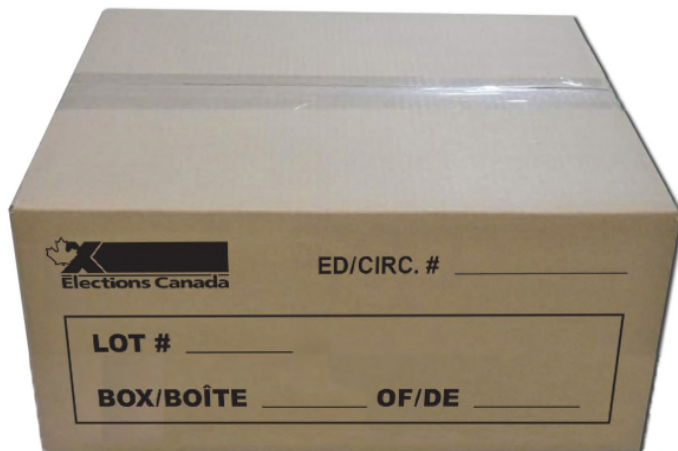

1.13 PACKAGING:

Ship flat strapped in bundles of 25's on skid
Clearly identify each skid in a minimum 20 pt type size as follows:

Label on skid:

<p style="text-align: center;">EC 10930 (03/2020) <i>Box for the return of election material / Boîte pour le retour du matériel électoral</i> <i>Qty / Qté – XXXXX boxes</i></p>

NOTE: Affix a label on each skid. The minimum size of the label must be 8.5" x 11".

Labeling of items going to the Distribution Centre must be exactly as indicated. If not, they will not be accepted.

**1.14 MANDATORY DELIVERY
DATE:**

On or before, but no later than August 28, 2020

Provided prior approval by the Project Authority, partial deliveries will be accepted but entire production must be delivered by **August 28, 2020**.

1.15 SHIPPING INSTRUCTIONS:

Ship on non-returnable shipping skids 48" wide by 42" deep. Pallets can be above the 54" high stacking height limit to reduce number of pallets. Supplier to use own discretion for stacking height while keeping the load secure.

The material must be accessible by hand held hydraulic pallet movers.

1.16 SKIDS:

Brewery type skid – 4 way entry type, 48" wide by 42" deep, 3 stringers with three blocks, each running 48" long

NOTE: Items shipped to the Distribution Centre not on requested skids will not be accepted upon delivery.

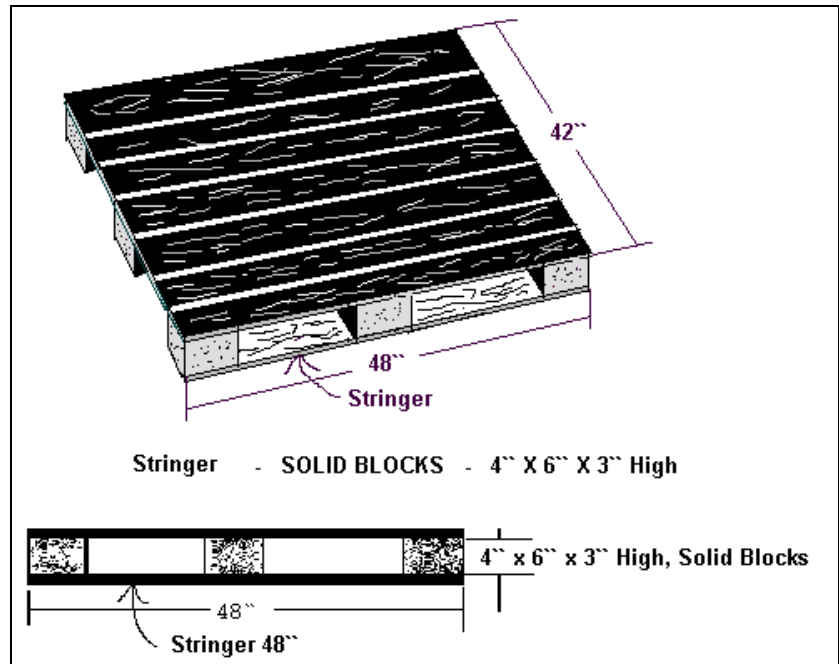

1.17 HOURS OF OPERATION :
(OTTAWA TIME)

8 a.m. to 12:00 noon / 1:00 p.m. to 4:00 p.m.

A written notice that a load is coming is appreciated. Please send to:
DistributionCentre-Centrededistribution@elections.ca

1.18 DESTINATION:

Elections Canada Distribution Centre
100-440 Coventry Road, Ottawa, Ontario K1K 2Y5

1.19 INVOICE:

Please send your invoice to the following address:

Fawn-Dell Flanagan
Material Management, OFG
Elections Canada
30 Victoria Street
Gatineau, Quebec K1A 0M6

Or by e-mail:

gestiondumaterielSGF-materialmanagementSMS@elections.ca

It is the responsibility of the supplier to provide a valid tax registration number for: HST, GST and QST, as applicable. Elections Canada will not validate tax registration numbers. If applicable taxes are invoiced without a tax registration number(s), Elections

Canada will not pay the applicable tax(es).

Invoices must indicate the Purchase Order number, if applicable, the Reference Number, the revision date and show any correction cost breakdown whenever it is applicable.

1.20 ADDITIONAL INFORMATION: No change in these specifications will be accepted unless approved by the project authority.

Elections Canada must be informed of the cost of any author's alterations as soon as possible. A contract amendment must be made as soon as any changes affecting cost occur.

The printer is to return to Elections Canada a final electronic file properly identified with all or any corrections made at the proofing stage before invoices are approved for payment.

Wrapping and shipping instructions must be followed to the letter or the Distribution Centre may refuse to accept the shipment.

APPENDIX A – DIAGRAM

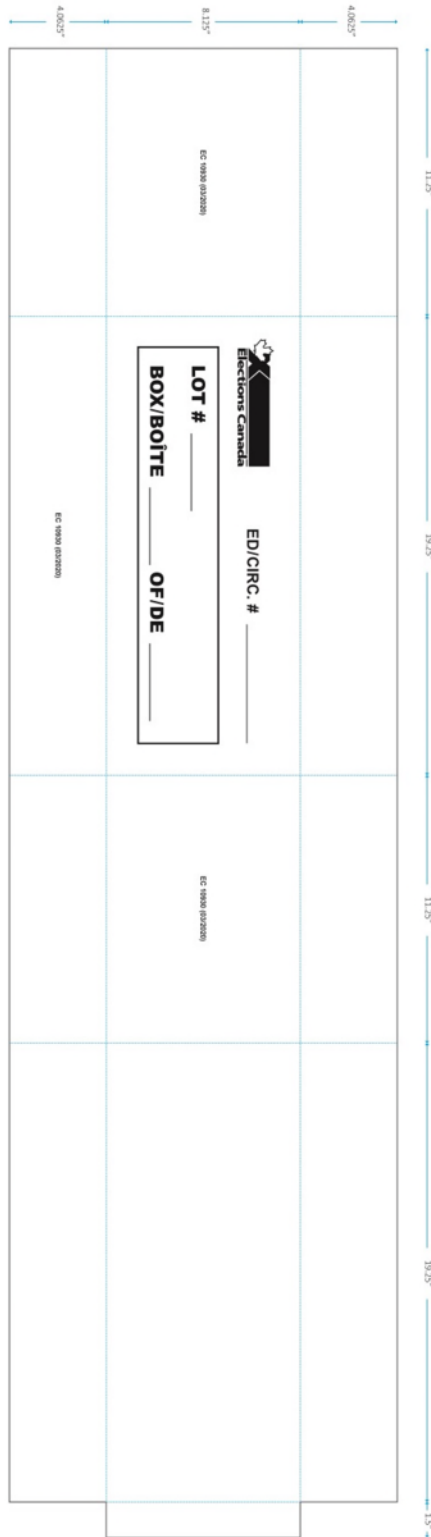

Item 2 – EC 40190

- 2.1 DESCRIPTION OF DELIVERABLE:** Production of a corrugated box with a removable lid.
- 2.2 REFERENCE NUMBER:** **EC 40190 (11/2018)**
- 2.3 TITLE:** Boxes for Revision Forms
- 2.4 QUANTITY :**
- 10,000 boxes and 10,000 lids
 - 2,000 shipping boxes
- 2.5 OVER:** ***No over / No under***
Elections Canada will not pay an invoice for items received in excess of the quantity stipulated in this specification, nor will it pay the full amount when items are sent in lower quantities than requested. It is the supplier's responsibility to ensure that items are shipped in the correct quantities
- 2.6 SIZE:** Inside dimension: 14.5" wide by 15" long by 9.5" high
- 2.7 TYPE:**
- Corrugated box
 - Two (2) piece die cut collapsible box with 3" removable lid
 - Self-locking base
- 2.8 PRINTING:** The winning supplier must:
- emboss inside the top of the lid the words: LID / COUVERCLE
 - emboss the word "BASE" on the bottom of the inside base
 - print the Elections Canada logo and information on one side of the box as per the camera-ready file that will be provided
 - print the assembly diagram on the outside bottom of the box as per the camera-ready file that will be provided
- 2.9 INK:** Black – no bleed
- 2.10 SPECIAL INSTRUCTIONS:** Two (2) die cut hinged hand holes required – centered on the 15" x 9.5" side

2.11 STOCK:

Corrugated fiberboard, 32 ECT, single wall, oyster white on the outer side. 200 PSI, B Flute.

2.12 IMAGES OF BOX:



2.13 IMAGES OF TEXT AND DIAGRAM:

Image of the text to be printed on one side of the box.

ELECTORAL DISTRICT / CIRCONSCRIPTION	
	POLLING DIVISIONS / SECTIONS DE VOTE
	FROM / DE _____ TO / À _____
IDENTIFY WHEN SHIPPING / IDENTIFIER LORS DE L'EXPÉDITION	
EC 40190 (11/2018)	BOX / BOÎTE _____ OF / DE _____

Image of the diagram to be printed on the outside bottom of the box.



See Appendix B for Diagrams of lid and base.

2.14 COMPONENT:

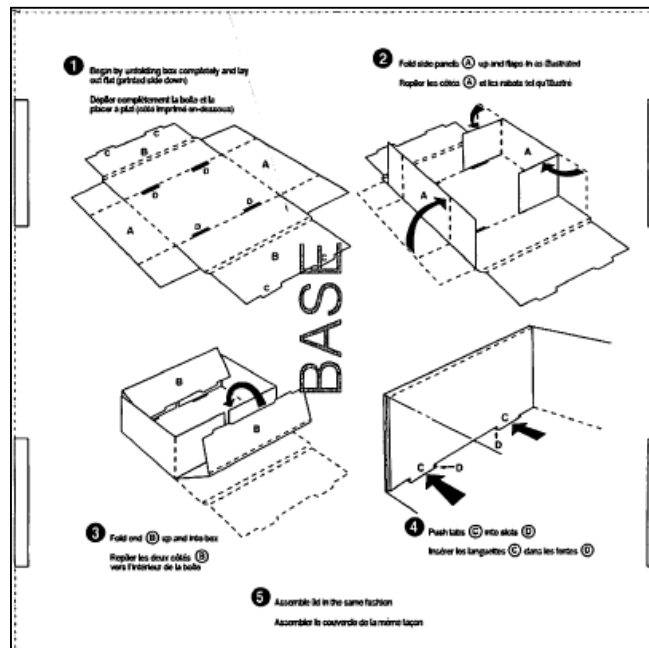
High resolution PDF files supplied for the text and logo to print on one side and bottom of the box.

NOTE: The cutting die is not available; it is the supplier responsibility to produce the die.

A sample of the box (base and lid) is available upon request.

**2.15 MANDATORY BOX
PROTOTYPE PROOF:**

A prototype of the 5 bases and 5 lids with the required text printed on paper and pasted in position on one the box are required before the start of the production.

See section 2.16.5 *Mandatory Box Prototype/Proof* for more details.

2.16 SHIPPING BOX:

2.16.1 The winning supplier will be responsible for providing a pizza style corrugated shipping box.

- a) The size of the shipping box to be determined by supplier;
- b) Each shipping box will contain 5 bases and 5 lids;
- c) Each shipping box must be made to fit very tightly the 5 bases and 5 lids with no space for movement or crushing;
- d) Boxes must not crush when stacked on skids; boxes that are crushed during shipping will be returned to the supplier for re-packaging.

2.16.2 Stock: Corrugated Cardboard, Single wall, ECT 32, 200 PSI, B Flute, Kraft

2.16.3 Printing on the shipping box:

On side panels:

- a) One colour black, to be centred on both side panels
- b) The winning supplier to typeset and print the EC product number, revision date, title of product and quantity
- c) Text size to be a minimum of 60 points
- d) Text to be printed in English on one side and French on the other side:

English side:

EC 40190 (11/2018) Boxes for Revision (5 bases/5 lids)

French side:**EC 40190 (11/2018) Boîtes pour révision (5 bases/5 couvercles)**

On top of box:

- a) One colour black
- b) The winning supplier to print the provided Elections Canada logo
- c) The size of the logo to be printed is approximately 6.25" wide by 1.75" high

2.16.4 Component:

A PDF of the Elections Canada logo will be supplied

NOTE: The cutting die for the shipping box is not available; it is the supplier responsibility to produce the die.

2.16.5 Mandatory Box Prototype/Proof:

A prototype of the corrugated shipping box with 5 base and 5 lids showing the printing on side panels and top must be sent to the Elections Canada Project Authority for sign-off prior to production.

2.17 PACKAGING:

Ship approximately 45 boxes of 5 sets per skid and shrink wrap entire skid securely to avoid shifting and crushing during transport.

2.18 MANDATORY DELIVERY DATE:

On or before, but no later than August 28, 2020

Provided prior approval by the Project Authority, partial deliveries will be accepted but entire production must be delivered by **August 28, 2020**.

2.19 SHIPPING INSTRUCTIONS:

Ship on non-returnable shipping skids 48" wide by 42" deep not to exceed 54" high stacking height. The material must be accessible by hand held hydraulic pallet movers.

2.20 SKIDS:

Brewery type skid – 4 way entry type, 48" wide by 42" deep, 3 stringers with three blocks, each running 48" long

NOTE: Items shipped to the Distribution Centre not on requested skids will not be accepted upon delivery.

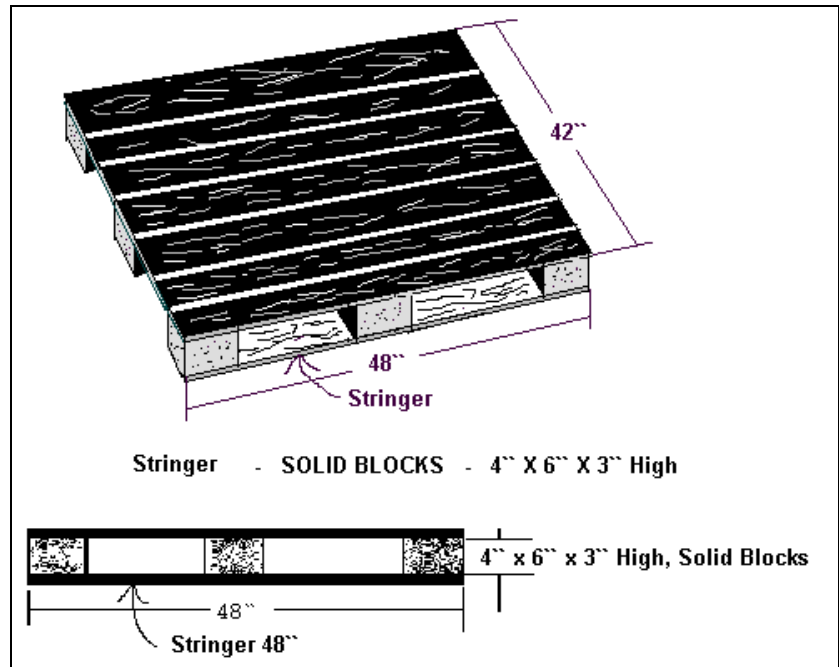
**2.21 HOURS OF OPERATION:
(Ottawa Time)**

8 a.m. to 12:00 noon / 1:00 p.m. to 4:00 p.m.

A written notice that a load is coming is appreciated. Please send to:
DistributionCentre-Centrededistribution@elections.ca

2.22 DESTINATION:

Elections Canada Distribution Centre
100-440 Coventry Road, Ottawa, Ontario K1K 2Y5

2.23 INVOICE:

Please send your invoice to the following address:

Fawn-Dell Flanagan
Material Management, OFG
Elections Canada
30 Victoria Street,
Gatineau, Quebec K1A 0M6

Or by e-mail to:

gestiondumatérielSGF-materialmanagementSMS@elections.ca

It is the responsibility of the supplier to provide a valid tax registration number for: HST, GST and QST, as applicable. Elections Canada will not validate tax registration numbers. If applicable taxes are invoiced without a tax registration number(s), Elections Canada will not pay the applicable tax(es).

Invoices must indicate the Purchase Order number, if applicable, the Reference Number, the revision date and show any correction cost breakdown whenever it is applicable

2.24 ADDITIONAL INFORMATION: No change in these specifications will be accepted unless approved by the project authority.

Elections Canada must be informed of the cost of any author's alterations as soon as possible. A contract amendment must be made as soon as any changes affecting cost occur.

The printer is to return to Elections Canada a final electronic file properly identified with all or any corrections made at the proofing stage before invoices are approved for payment.

Wrapping and shipping instructions must be followed to the letter or the Distribution Centre may refuse to accept the shipment.

APPENDIX B –DIAGRAMS OF LID AND BASE

