

## INVITATION TO TENDER

**RETURN BIDS TO:**

**Bid Receiving / Agriculture and Agri-Food Canada**

Agriculture and Agri-Food Canada  
 Eastern Service Centre  
 Tender Receiving Unit  
 2001 Robert-Bourassa Blvd., Suite 671-TEN  
 Montréal, Quebec  
 H3A 3N2

**TENDER TO:**

**Agriculture and Agri-Food Canada**

We hereby offer to sell to Her Majesty the Queen in right of Canada, in accordance with the terms and conditions set out herein, referred to herein or attached hereto, the construction listed herein and on any attached sheets at the price(s) set out therefor.

Comments Site visit will take place on September 11, 2020 at 10:30 AM at the Frelighsburg Experimental Farm located at 57 chemin St-Armand, Frelighsburg (Québec) J0J 1C0.
---

Title Surface water drainage work around Building # 18 - Frelighsburg Experimental Farm.	
Solicitation No. 01B46-20-045	Date 2020-09-02
Client Reference No.	
File No.	
Solicitation Closes: Monday, September 21, 2020, at 02:00 PM, EDT.	
F.O.B <input type="radio"/> Plant <input type="radio"/> Destination <input type="radio"/> Other	
Address Enquiries to: Carol Rahal	
Title: Senior contracting agent and accomodation	
Email: carol.rahal@canada.ca	
Telephone Number    Ext. 418 928-1059	Fax Number 514 283-1918
Destination Frelighsburg Experimental Farm 57 chemin St-Armand Frelighsburg (Québec) J0J 1C0	

**Instructions: See Herein**

Delivery Required March 31, 2021	Delivery Offered
Vendor / Firm Name and Address	
Telephone Number    Ext.	Fax Number
Name and title of person authorized to sign on behalf of Vendor / Firm (type or print)	
Signature	Date

**ISSUING OFFICE**

Agriculture and Agri-Food Canada  
 Eastern Service Centre  
 Tender Receiving Unit  
 2001 Robert-Bourassa Blvd., Suite 671-TEN  
 Montréal, Quebec  
 H3A 3N2



## TABLE OF CONTENTS

1. Invitation to Tender [AAC 5323](#)
2. Appendix "A" / General Instructions to Bidders [AAC 5313](#)
3. Appendix "B" / Special Instructions to Bidders [AAC 5301](#)
4. Appendix "C" / Bid and Acceptance Form [AAC 5320](#)
5. Appendix "D" / Major Works - General Conditions [AAC 5321](#)
6. Appendix "E" / Performance Specifications & Specifications for deconstruction-dismantling & Plans
7. Appendix "F" / Insurance Terms [AAC 5315](#)
8. Appendix "G" / Contract Documents [AAC 5322](#)
9. Appendix "H" / Contract [AAC 5324](#)
10. Appendix "I" / Guidance for Contractors Working in AAFC Buildings

### Forms

- Bid Bond [AAC 5302](#)
- Certificate of Insurance [AAC 5314](#)
- Labour and Material Payment Bond [AAC 5304](#)
- Performance Bond [AAC 5303](#)
- T4-A Certification



## **Appendix "A"**

### **GENERAL INSTRUCTIONS TO BIDDERS**

## GENERAL INSTRUCTIONS TO BIDDERS

- GI01 Completion of Bid
- GI02 Identity or Legal Capacity of the Bidder
- GI03 Applicable Taxes
- GI04 Capital Development and Redevelopment Charges
- GI05 Registry and Pre-qualification of Floating Plant
- GI06 Listing of Subcontractors and Suppliers
- GI07 Bid Security Requirements
- GI08 Submission of Bid
- GI09 Revision of Bid
- GI10 Rejection of Bid
- GI11 Bid Costs
- GI12 Compliance with Applicable Laws
- GI13 Approval of Alternative Materials
- GI14 Conflict of Interest – Unfair Advantage
- GI15 Integrity Provisions – Bid
- GI16 Code of Conduct for Procurement – Bid

### GI01 COMPLETION OF BID

- 1) The bid shall be:
  - (a) submitted on the BID AND ACCEPTANCE FORM provided by AAFC with the bid package or on a clear and legible reproduced copy of such BID AND ACCEPTANCE FORM that must be identical in content and format to the BID AND ACCEPTANCE FORM provided by AAFC;
  - (b) based on the Bid Documents listed in the Special Instructions to Bidders;
  - (c) correctly completed in all respects;
  - (d) signed, with an original signature, by a duly authorized representative of the Bidder; and
  - (e) accompanied by
    - (i) bid security as specified in GI07; and
    - (ii) any other document or documents specified elsewhere in the solicitation where it is stipulated that said documents are to accompany the bid.
- 2) Subject to paragraph 6) of GI10, any alteration to the pre-printed or pre-typed sections of the Bid and Acceptance Form, or any condition or qualification placed upon the bid shall be cause for disqualification. Alterations, corrections, changes or erasures made to statements or figures entered on the Bid and Acceptance Form by the Bidder shall be initialed by the person or persons signing the bid. Alterations, corrections, changes or erasures that are not initialed shall be deemed void and without effect.
- 3) Unless otherwise noted elsewhere in the Bid Documents, facsimile copies of bids are not acceptable.

## **GENERAL INSTRUCTIONS TO BIDDERS (Continued)**

### **GI02 IDENTITY OR LEGAL CAPACITY OF THE BIDDER**

- 1) In order to confirm the authority of the person or persons signing the bid or to establish the legal capacity under which the Bidder proposes to enter into Contract, any Bidder who carries on business in other than its own personal name shall, if requested by Canada, provide satisfactory proof of
  - (a) such signing authority; and
  - (b) the legal capacity under which it carries on business;

prior to contract award. Proof of signing authority may be in the form of a certified copy of a resolution naming the signatory(ies) that is (are) authorized to sign this bid on behalf of the corporation or partnership. Proof of legal capacity may be in the form of a copy of the articles of incorporation or the registration of the business name of a sole proprietor or partnership.

### **GI03 APPLICABLE TAXES**

- 1) "Applicable Taxes" means the Goods and Services Tax (GST), the Harmonized Sales Tax (HST), and any provincial tax, by law, payable by Canada such as, the Quebec Sales Tax (QST) as of April 1, 2013.

### **GI04 CAPITAL DEVELOPMENT AND REDEVELOPMENT CHARGES**

- 1) For the purposes of GC1.8 LAWS, PERMITS AND TAXES in the General Conditions of the Contract, only fees or charges directly related to the processing and issuing of building permits shall be included. The Bidder shall not include any monies in the bid amount for special municipal development, redevelopment or other fees or charges which a municipal authority may seek as a prerequisite to the issuance of building permits.

### **GI05 REGISTRY AND PRE-QUALIFICATION OF FLOATING PLANT**

- 1) Dredges or other floating plant to be used in the performance of the Work must be of Canadian registry. For dredges or other floating plant that are not of Canadian make or manufacture, the Bidder must obtain a certificate of qualification from Industry Canada and this certificate must accompany the bid. Plant so qualified by Industry Canada may be accepted on this project.

### **GI06 LISTING OF SUBCONTRACTORS AND SUPPLIERS**

- 1) Notwithstanding any list of Subcontractors that the Bidder may be required to submit as part of the bid, the Bidder shall, within 48 hours of receipt of a notice to do so, submit all information requested in the said notice including the names of Subcontractors and Suppliers for the part or parts of the Work listed. Failure to do so shall result in the disqualification of its bid.

### **GI07 BID SECURITY REQUIREMENTS**

- 1) The Bidder shall submit bid security with the bid in the form of a bid bond or a security deposit in an amount that is equal to not less than 10 percent of the bid amount. Applicable Taxes shall not be included when calculating the amount of any bid security that may be required. The maximum amount of bid security required with any bid is \$2,000,000.00.

## GENERAL INSTRUCTIONS TO BIDDERS (Continued)

- 2) A bid bond shall be in an approved form <http://www.tbs-sct.gc.ca/pol/doc-eng.aspx?id=14494#appS>, properly completed, with original signature(s) and issued by an approved company whose bonds are acceptable to Canada either at the time of solicitation closing or as identified in Treasury Board Appendix L: [Acceptable Bonding Companies](#).
- 3) A security deposit shall be an original, properly completed, signed where required and be either:
  - (a) a bill of exchange, bank draft or money order made payable to the Receiver General for Canada and certified by an approved financial institution or drawn by an approved financial institution on itself; or
  - (b) bonds of, or unconditionally guaranteed as to principal and interest by, the Government of Canada;
- 4) For the purposes of subparagraph 3) (a) of GI07
  - (a) a bill of exchange is an unconditional order in writing signed by the Bidder and addressed to an approved financial institution, requiring the said institution to pay, on demand, at a fixed or determinable future time a sum certain of money to, or to the order of, the Receiver General for Canada;
  - (b) if a bill of exchange, bank draft or money order is certified by or drawn on an institution or corporation other than a chartered bank, it must be accompanied by proof that the said institution or corporation meets at least one of the criteria described in subparagraph 4.c. of GI07, either by letter or by a stamped certification on the bill of exchange, bank draft or money; and
  - (c) An approved financial institution is:
    - (i) a corporation or institution that is a member of the Canadian Payments Association as defined in the [Canadian Payments Act](#);
    - (ii) a corporation that accepts deposits that are insured, to the maximum permitted by law, by the Canada Deposit Insurance Corporation or the "Autorité des marchés financiers";
    - (iii) a corporation that accepts deposits from the public if repayment of the deposit is guaranteed by Her Majesty the Queen in right of a province;
    - (iv) a corporation, association or federation incorporated or organized as a credit union or co-operative credit society that conforms to the requirements of a credit union which are more particularly described in paragraph 137(6) of the [Income Tax Act](#); or
    - (v) Canada Post Corporation.
- 5) Bonds referred to in subparagraph 3)(b) of GI07 shall be provided on the basis of their market value current at the date of solicitation closing, and shall be:
  - (a) payable to bearer;
  - (b) accompanied by a duly executed instrument of transfer of the bonds to the Receiver General for Canada in the form prescribed by the Domestic Bonds of Canada Regulations; or
  - (c) registered as to principal or as to principal and interest in the name of the Receiver General for Canada pursuant to the Domestic Bonds of Canada Regulations.

## GENERAL INSTRUCTIONS TO BIDDERS (Continued)

- 6) As an alternative to a security deposit an irrevocable standby letter of credit is acceptable to Canada and the amount shall be determined in the same manner as a security deposit referred to above.
- 7) An irrevocable standby letter of credit referred to in paragraph 6) of GI07 shall
  - (a) be an arrangement, however named or described, whereby a financial institution (the "Issuer") acting at the request and on the instructions of a customer (the "Applicant") or on its own behalf,
    - (i) is to make a payment to, or to the order of, the Receiver General for Canada as the beneficiary;
    - (ii) is to accept and pay bills of exchange drawn by the Receiver General for Canada;
    - (iii) authorizes another financial institution to effect such payment or accept and pay such bills of exchange; or
    - (iv) authorizes another financial institution to negotiate against written demand(s) for payment provided that the terms and conditions of the letter of credit are complied with;
  - (b) state the face amount which may be drawn against it;
  - (c) state its expiry date;
  - (d) provide for sight payment to the Receiver General for Canada by way of the financial institution's draft against presentation of a written demand for payment signed by the Departmental Representative identified in the letter of credit by his/her office;
  - (e) provide that more than one written demand for payment may be presented subject to the sum of those demands not exceeding the face value of the letter of credit;
  - (f) provide that it is subject to the International Chamber of Commerce (ICC) Uniform Customs and Practice (UCP) for Documentary Credits, 2007 Revision, ICC Publication No. 600; pursuant to the ICC UCP; a credit is irrevocable even if there is no indication to that effect; and
  - (g) be issued or confirmed, in either official language, by a financial institution which is a member of the Canadian Payments Association and is on the letterhead of the Issuer or Confirmer. The format is left to the discretion of the Issuer or Confirmer.
- 8) Bid security shall lapse or be returned as soon as practical following:
  - (a) the solicitation closing date, for those Bidders submitting non-compliant bids; and
  - (b) the administrative bid review, for those Bidders submitting compliant bids ranked fourth to last on the schedule of bids; and
  - (c) the award of contract, for those Bidders submitting the second and third ranked bids; and
  - (d) the receipt of contract security, for the successful Bidder; or
  - (e) the cancellation of the solicitation, for all Bidders.
- 9) Notwithstanding the provisions of paragraph 8) of GI07 and provided more than three compliant bids have been received, if one or more of the bids ranked third to first is withdrawn or rejected for whatever reason then Canada reserves the right to hold the security of the next highest ranked compliant bid in order to retain the bid security of at least three valid and compliant bids.

## **GENERAL INSTRUCTIONS TO BIDDERS (Continued)**

### **GI08 SUBMISSION OF BID**

- 1) The Bid and Acceptance Form, duly completed, and the bid security shall be enclosed and sealed in an envelope provided by the Bidder, and shall be addressed and submitted to the office designated on the INVITATION TO TENDER Form for the receipt of bids. The bid must be received on or before the date and time set for solicitation closing.
- 2) Unless otherwise specified in the Special Instructions to Bidders
  - (a) the bid shall be in Canadian currency;
  - (b) exchange rate fluctuation protection is not offered; and
  - (c) any request for exchange rate fluctuation protection shall not be considered.
- 3) Prior to submitting the bid, the Bidder shall ensure that the following information is clearly printed or typed on the face of the bid envelope:
  - (a) Solicitation Number;
  - (b) Name of Bidder;
  - (c) Return address; and
  - (d) Closing Date and Time.
- 4) Timely and correct delivery of bids is the sole responsibility of the Bidder.

### **GI09 REVISION OF BID**

- 1) A bid submitted in accordance with these instructions may be revised by letter or facsimile provided the revision is received at the office designated for the receipt of bids, on or before the date and time set for the closing of the solicitation. The letter or facsimile shall be on the Bidder's letterhead or bear a signature that identifies the Bidder;
- 2) A revision to a bid that includes unit prices must clearly identify the changes(s) in the unit price(s) and the specific item(s) to which each change applies.
- 3) A letter or facsimile submitted to confirm an earlier revision shall be clearly identified as a confirmation.
- 4) Failure to comply with any of the above provisions shall result in the rejection of the non-compliant revision(s) only. The bid shall be evaluated based on the original bid submitted and all other compliant revision(s).

### **GI10 REJECTION OF BID**

- 1) Canada may accept any bid, whether it is the lowest or not, or may reject any or all bids.
- 2) Without limiting the generality of paragraph 1) of GI10, Canada may reject a bid if any of the following circumstances is present:
  - (a) the Bidder, or any employee or subcontractor included as part of the bid, has been



## GENERAL INSTRUCTIONS TO BIDDERS (Continued)

- convicted under Section 121 ("Frauds on the government" & "Contractor subscribing to election fund"), 124 "Selling or purchasing office"), 380 ("Fraud committed against Her Majesty") or 418 ("Selling defective stores to Her Majesty") of the Criminal Code of Canada, or under paragraph 80(1)(d) ("False entry, certificate or return"), subsection 80(2) ("Fraud against Her Majesty") or Section 154.01 ("Fraud against Her Majesty") of the *Financial Administration Act*;
- (b) the Bidder's bidding privileges are suspended or are in the process of being suspended;
  - (c) the bidding privileges of any employee or subcontractor included as part of the bid are suspended or are in the process of being suspended, which suspension or pending suspension would render that employee or subcontractor ineligible to bid on the Work, or the portion of the Work the employee or subcontractor is to perform;
  - (d) the Bidder is bankrupt, or where for whatever reason, its activities are rendered inoperable for an extended period;
  - (e) evidence, satisfactory to Canada, of fraud, bribery, fraudulent misrepresentation or failure to comply with any law protecting individuals against any manner of discrimination, has been received with respect to the Bidder, any of its employees or any subcontractor included as part of its bid;
  - (f) evidence satisfactory to Canada that based on past conduct or behavior, the Bidder, a sub-contractor or a person who is to perform the Work is unsuitable or has conducted himself/herself improperly;
  - (g) with respect to current or prior transactions with Canada
    - (i) Canada has exercised, or intends to exercise, the contractual remedy of taking the work out of the contractor's hands with respect to a contract with the Bidder, any of its employees or any subcontractor included as part of its bid; or
    - (ii) Canada determines that the Bidder's performance on other contracts is sufficiently poor to jeopardize the successful completion of the requirement being bid on.
- 3) In assessing the Bidder's performance on other contracts pursuant to subparagraph 2)(g)(ii) of GI10, Canada may consider, but not be limited to, such matters as:
- (a) the quality of workmanship in performing the Work;
  - (b) the timeliness of completion of the Work;
  - (c) the overall management of the Work and its effect on the level of effort demanded of the department and its representative; and
  - (d) the completeness and effectiveness of the Contractor's safety program during the performance of the Work.
- 4) Without limiting the generality of paragraphs 1), 2) and 3) of GI10, Canada may reject any bid based on an unfavourable assessment of the:
- (a) adequacy of the bid price to permit the work to be carried out and, in the case of a bid providing prices per unit or a combination of lump sum and prices per unit, whether each such price reasonably reflects the cost of performing the part of the work to which that

## **GENERAL INSTRUCTIONS TO BIDDERS (Continued)**

price applies;

- (b) Bidder's ability to provide the necessary management structure, skilled personnel, experience and equipment to perform competently the work under the Contract; and
  - (c) Bidder's performance on other contracts.
- 5) Where Canada intends to reject a bid pursuant to a provision of paragraphs 1), 2), 3) or 4) of GI10, other than subparagraph 2)(g) of IT10, the contracting authority will inform the Bidder and provide the Bidder ten (10) days within which to make representations, before making a final decision on the bid rejection.
- 6) Canada may waive informalities and minor irregularities in bids received if Canada determines that the variation of the bid from the exact requirements set out in the Bid Documents can be corrected or waived without being prejudicial to other Bidders.

### **GI11 BID COSTS**

- 1) No payment will be made for costs incurred in the preparation and submission of a bid in response to the bid solicitation. Costs associated with preparing and submitting a bid, as well as any costs incurred by the Bidder associated with the evaluation of the bid, are the sole responsibility of the Bidder.

### **GI12 COMPLIANCE WITH APPLICABLE LAWS**

- 1) By submission of a bid, the Bidder certifies that the Bidder has the legal capacity to enter into a contract and is in possession of all valid licences, permits, registrations, certificates, declarations, filings, or other authorizations necessary to comply with all federal, provincial and municipal laws and regulations applicable to the submission of the bid and entry into any ensuing contract for the performance of the work.
- 2) For the purpose of validating the certification in paragraph 1) of GI12, a Bidder shall, if requested, provide a copy of every valid licence, permit, registration, certificate, declaration, filing or other authorization listed in the request, and shall provide such documentation within the time limit(s) set out in the said request.
- 3) Failure to comply with the requirements of paragraph 2) of GI12 shall result in disqualification of the bid.

### **GI13 APPROVAL OF ALTERNATIVE MATERIALS**

- 1) When materials are specified by trade names or trademarks, or by manufacturers' or suppliers' names, the bid shall be based on use of the named materials. During the solicitation period, alternative materials may be considered provided full technical data is received in writing by the Contracting Officer at least 10 calendar days prior to the solicitation closing date.

### **GI14 CONFLICT OF INTEREST - UNFAIR ADVANTAGE**

- 1) In order to protect the integrity of the procurement process, bidders are advised that Canada may reject a bid in the following circumstances:
- (a) if the Bidder, any of its subcontractors, any of their respective employees or former

## GENERAL INSTRUCTIONS TO BIDDERS (Continued)

employees was involved in any manner in the preparation of the bid solicitation or in any situation of conflict of interest or appearance of conflict of interest;

- (b) if the Bidder, any of its subcontractors, any of their respective employees or former employees had access to information related to the bid solicitation that was not available to other bidders and that would, in Canada's opinion, give or appear to give the Bidder an unfair advantage.
- 2) The experience acquired by a bidder who is providing or has provided the goods and services described in the bid solicitation (or similar goods or services) will not, in itself, be considered by Canada as conferring an unfair advantage or creating a conflict of interest. This bidder remains however subject to the criteria established above.
  - 3) Where Canada intends to reject a bid under this section, the Contracting Authority will inform the Bidder and provide the Bidder an opportunity to make representations before making a final decision. Bidders who are in doubt about a particular situation should contact the Contracting Authority before bid closing. By submitting a bid, the Bidder represents that it does not consider itself to be in conflict of interest nor to have an unfair advantage. The Bidder acknowledges that it is within Canada's sole discretion to determine whether a conflict of interest, unfair advantage or an appearance of conflict of interest or unfair advantage exists.

### GI15 INTEGRITY PROVISIONS - BID

- 1) Ineligibility and Suspension Policy (the "Policy"), and all related Directives, are incorporated by reference into, and form a binding part of the procurement process. The Supplier must comply with the Policy and Directives, which can be found at *Ineligibility and Suspension Policy*.
- 2) Under the Policy, charges and convictions of certain offences against a Supplier, its affiliates or first tier subcontractors, and other circumstances, will or may result in a determination by Public Works and Government Services Canada (PWGSC) that the Supplier is ineligible to enter, or is suspended from entering into a contract with Canada. The list of ineligible and suspended Suppliers is contained in PWGSC's Integrity Database. The Policy describes how enquiries can be made regarding the ineligibility or suspension of Suppliers.
- 3) In addition to all other information required in the procurement process, the Supplier must provide the following:
  - a. by the time stated in the Policy, all information required by the Policy described under the heading "Information to be Provided when Bidding, Contracting or Entering into a Real Property Agreement"; and
  - b. with its bid / quote / proposal, a complete list of all foreign criminal charges and convictions pertaining to itself, its affiliates and its proposed first tier subcontractors that, to the best of its knowledge and belief, may be similar to one of the listed offences in the Policy. The list of foreign criminal charges and convictions must be submitted using an Integrity Declaration Form, which can be found at [Declaration form for procurement](#).
- 4) Subject to subsection 5, by submitting a bid / quote / proposal in response a request by AAFC, the Supplier certifies that:
  - a. it has read and understands the *Ineligibility and Suspension Policy*;
  - b. it understands that certain domestic and foreign criminal charges and convictions, and

## GENERAL INSTRUCTIONS TO BIDDERS (Continued)

- other circumstances, as described in the Policy, will or may result in a determination of ineligibility or suspension under the Policy;
- c. it is aware that Canada may request additional information, certifications, and validations from the Supplier or a third party for purposes of making a determination of ineligibility or suspension;
  - d. it has provided with its bid / quote / proposal a complete list of all foreign criminal charges and convictions pertaining to itself, its affiliates and its proposed first tier subcontractors that, to the best of its knowledge and belief, may be similar to one of the listed offences in the Policy;
  - e. none of the domestic criminal offences, and other circumstances, described in the Policy that will or may result in a determination of ineligibility or suspension, apply to it, its affiliates and its proposed first tier subcontractors; and
  - f. it is not aware of a determination of ineligibility or suspension issued by PWGSC that applies to it.
- 5) Where a Supplier is unable to provide any of the certifications required by subsection 4, it must submit with its bid/ quote / proposal a completed Integrity Declaration Form, which can be found at [Declaration form for procurement](#).
- 6) Canada will declare non-responsive any bid / quote / proposal in respect of which the information requested is incomplete or inaccurate, or in respect of which the information contained in a certification or declaration is found by Canada to be false or misleading in any respect. If Canada establishes after award of the Contract that the Supplier provided a false or misleading certification or declaration, Canada may terminate the Contract for default. Pursuant to the Policy, Canada may also determine the Supplier to be ineligible for award of a contract for providing a false or misleading certification or declaration.

Ineligibility and Suspension Policy - <http://www.tpsgc-pwgsc.gc.ca/ci-if/politique-policy-eng.html>

Declaration form for procurement - <http://www.tpsgc-pwgsc.gc.ca/ci-if/declaration-eng.html>

### GI16 CODE OF CONDUCT FOR PROCUREMENT - BID

- 1) The Code of Conduct for Procurement provides that Bidders must respond to bid solicitations in an honest, fair and comprehensive manner, accurately reflect their capacity to satisfy the requirements set out in the bid solicitation and resulting contract, submit bids and enter into contracts only if they will fulfill all obligations of the Contract. By submitting a bid, the Bidder is certifying that it is complying with the Code of Conduct for Procurement. Failure to comply with the Code of Conduct for Procurement may render the bid non-responsive.



## **Appendix "B"**

### **SPECIAL INSTRUCTIONS TO BIDDERS**

## SPECIAL INSTRUCTIONS TO BIDDERS (SI)

SI01	Bid Documents
SI02	Enquiries during the Solicitation Period
SI03	Non-Mandatory Site Visit
S104	Revision of Bid
S105	Bid Results
SI06	Insufficient Funds
SI07	Bid Validity Period
SI08	Construction Documents
SI09	Web Sites
SI10	Personnel Security Requirements

### SI01 BID DOCUMENTS

- 1) The following are the bid documents:
  - (a) INVITATION TO TENDER - Page 1 form AAFC / AAC5323-E;
  - (b) SPECIAL INSTRUCTIONS TO BIDDERS form AAFC / AAC5301-E;
  - (c) GENERAL INSTRUCTIONS TO BIDDERS form AAFC / AAC5313-E;
  - (d) Clauses and Conditions identified in "CONTRACT DOCUMENTS";
  - (e) Drawings and Specifications;
  - (f) BID AND ACCEPTANCE form AAFC / AAC5320-E and any Appendices attached thereto; and,
  - (g) Any amendment issued prior to solicitation closing.

Submission of a bid constitutes acknowledgement that the Bidder has read and agrees to be bound by these documents.

### SI02 ENQUIRIES DURING THE SOLICITATION PERIOD

- 1) Enquiries regarding this bid must be submitted in writing to the Contracting Officer named on the INVITATION TO TENDER - Page 1 as early as possible within the solicitation period. Except for the approval of alternative materials as described in G113 of the GENERAL INSTRUCTIONS TO BIDDERS, enquiries should be received no later than five (5) calendar days prior to the date set for solicitation closing to allow sufficient time to provide a response. Enquiries received after that time may not result in an answer being provided.
- 2) To ensure consistency and quality of the information provided to Bidders, the Contracting Officer shall examine the content of the enquiry and shall decide whether or not to issue an amendment.
- 3) All enquiries and other communications related to this bid sent throughout the solicitation period are to be directed ONLY to the Contracting Officer named on the INVITATION TO TENDER - Page 1. Non-compliance with this requirement during the solicitation period can, for that reason alone, result in disqualification of a bid.

### SI03 NON-MANDATORY SITE VISIT

- 1) There will be a site visit on Friday,            September,    11            , 2020 at  
10:30  AM  PM EDT.

## **SPECIAL INSTRUCTIONS TO BIDDERS (Continued)**

Interested bidders are to meet at:

Frelighsburg Experimental Farm  
57 chemin St-Armand  
Frelighsburg (Québec)  
J0J 1C0

Interested bidders to attend the site visit will need to confirm their presence by sending an email to [carol.rahal@canada.ca](mailto:carol.rahal@canada.ca).

Confirmation by email is mandatory before attending the site visit. During the site visit, wearing a mask is mandatory.

### **SI04 REVISION OF BID**

- 1) A bid may be revised by letter or facsimile in accordance with GI09 of the GENERAL INSTRUCTIONS TO BIDDERS. The facsimile number for receipt of revisions is 514 283-1918 .

### **SI05 BID RESULTS**

- 1) Following bid closing, bid results may be obtained from the bid receiving office by email at [carol.rahal@canada.ca](mailto:carol.rahal@canada.ca) .

### **SI06 INSUFFICIENT FUNDING**

- 1) In the event that the lowest compliant bid exceeds the amount of funding allocated for the Work, Canada in its sole discretion may:
  - (a) cancel the solicitation; or
  - (b) obtain additional funding and award the Contract to the Bidder submitting the lowest compliant bid; and/or
  - (c) negotiate a reduction in the bid price and/or scope of work of not more than 15% with the Bidder submitting the lowest compliant bid. Should an agreement satisfactory to Canada not be reached, Canada shall exercise option (a) or (b).

### **SI07 BID VALIDITY PERIOD**

- 1) Canada reserves the right to seek an extension to the bid validity period prescribed in Clause 4 of the BID AND ACCEPTANCE Form. Upon notification in writing from Canada, Bidders shall have the option to either accept or reject the proposed extension.
- 2) If the extension referred to in paragraph 1) of SI07 is accepted, in writing, by all those who submitted bids, then Canada shall continue immediately with the evaluation of the bids and its approvals processes.
- 3) If the extension referred to in paragraph 1) of SI07 is not accepted in writing by all those who submitted bids then Canada shall, at its sole discretion, either:
  - (a) continue to evaluate the bids of those who have accepted the proposed extension and seek the necessary approvals; or
  - (b) cancel the invitation to bid.

## **SPECIAL INSTRUCTIONS TO BIDDERS (Continued)**

- 4) The provisions expressed herein do not in any manner limit Canada's rights in law or under GI10 of the GENERAL INSTRUCTIONS TO BIDDERS.

### **SI08 CONSTRUCTION DOCUMENTS**

- 1) The successful contractor will be provided with one paper copy of the sealed and signed plans, the specifications and the amendments upon acceptance of the offer. Additional copies, up to a maximum of one ( 1 ), will be provided free of charge upon request by the Contractor. Obtaining more copies shall be the responsibility of the Contractor including costs.

### **SI09 WEB SITES**

The connection to some of the Web sites in the solicitation documents is established by the use of hyperlinks. The following is a list of the addresses of the Web sites:

Treasury Board Appendix L, Acceptable Bonding Companies

<http://www.tbs-sct.gc.ca/pol/doc-eng.aspx?id=14494&section=text#appL>

Canadian economic sanctions

<http://www.international.gc.ca/sanctions/index.aspx?lang=eng>

### **SI10 PERSONNEL SECURITY REQUIREMENTS**

- 1) The successful Bidder's personnel, as well as any subcontractor and its personnel, who are required to perform any part of the work pursuant to the subsequent contract, must meet the following contract security requirements:
  - Unscreened personnel may be used for the work. Unscreened personnel will require an escort provided by AAFC.





## **Appendix "C"**

### **BID AND ACCEPTANCE FORM**

## BID AND ACCEPTANCE FORM

### CONSTRUCTION CONTRACT - MAJOR WORKS

<b>BA01 IDENTIFICATION</b>					
Description of the Work Agriculture and Agri-Food Canada's Frelighsburg Experimental Farm plans to redo the drainage around building # 18 for the evacuation of the surface water. The works consist, but are not limited to: <ul style="list-style-type: none"> <li>• The construction survey</li> <li>• Signalisation and traffic management</li> <li>• Demolition of existing structures such as paving, existing storm sewers and aqueduct pipes, etc.</li> <li>• Relocation of the water pumping station and reservoir</li> <li>• The excavation and connection of a water main</li> <li>• The excavation and installation of storm water pipes including the required catch basins</li> <li>• Construction of a drainage trench</li> <li>• The excavation, leveling and compaction of the stone foundation for light paving</li> <li>• Installation and compaction of paving</li> <li>• Pavement sawing</li> <li>• Sodding</li> <li>• Protection of existing services; aqueduct, gas and others</li> <li>• Environmental measures and management of cut / fill</li> </ul>					
Solicitation Number 01B46-20-045			File / Project Number		
<b>BA02 BUSINESS NAME AND ADDRESS OF BIDDER</b>					
Name					
Address					
Unit/Suite/Apt.	Street number	Number suffix	Street name	Street type	Street direction
PO Box or Route Number			Municipality (City, Town, etc.)	Province	Postal code
Phone number		Fax number		Email address	
<b>BA03 THE OFFER</b>					
1) The Bidder offers to Canada as represented by the Minister of Agriculture and Agri-food Canada to perform and complete the Work for the above named project in accordance with the Bid Documents for the Total Bid Amount of: \$ _____ excluding Applicable Taxes (GST/HST/QST). (to be expressed in numbers only)					
<b>BA04 BID VALIDITY PERIOD</b>					
1) The bid shall not be withdrawn for a period of <u>60</u> days following the date of solicitation closing.					
<b>BA05 APPENDICES</b>					
1) The following appendices are included in this Bid and Acceptance Form: <input checked="" type="checkbox"/> Appendix 2					
<b>BA06 ACCEPTANCE AND CONTRACT</b>					
1) Upon acceptance of the Bidder's offer by Canada, a binding Contract shall be formed between Canada and the resulting Contractor. The documents forming the Contract shall be the contract documents referred to in SC01 CONTRACT DOCUMENTS.					
<b>BA07 CONSTRUCTION TIME</b>					
1) The Contractor shall perform and complete the Work <u>on or before 2021-03-31</u>					
<b>BA08 BID SECURITY</b>					
1) The Bidder shall enclose bid security with its bid in accordance with GI07 BID SECURITY REQUIREMENTS.					

2) If a security deposit is furnished as bid security, it shall be forfeited in the event that the bid is accepted by Canada and the Contractor fails to provide Contract Security in accordance with GC9 CONTRACT SECURITY, provided that Canada may, if it is in the public interest, waive the right of Canada to forfeiture any or all of the security deposit.

**BA09 SIGNATURE**

Name and title of person authorized to sign on behalf of Bidder (type or print)	Name
	Title
	_____
	Signature _____ Date _____
	Name
	Title
_____	
Signature _____ Date _____	

**BA10 INTEGRITY PROVISIONS - LIST OF NAMES**

If the required list of names has not been received by the time the evaluation of bids is completed, Canada will inform the Bidder of a time frame within which to provide the information. Failure to provide the names within the time frame specified will render the bid non-responsive. Providing the required names is a mandatory requirement for contract award.

Bidders who are incorporated, including those bidding as a joint venture, must provide a complete list of names of all individuals who are currently directors of the Bidder.

Bidders bidding as sole proprietorship, as well as those bidding as a joint venture, must provide the name of the owner(s).

Bidders bidding as societies, firms or partnerships do not need to provide lists of names.

_____	_____	_____
_____	_____	_____
_____	_____	_____
_____	_____	_____
_____	_____	_____

**BID AND ACCEPTANCE FORM**  
CONSTRUCTION CONTRACT - MAJOR WORKS  
APPENDIX 2

**LIST OF SUBCONTRACTORS**

The Bidder will subcontract the parts of the work listed below to the subcontractor named for each part. The Bidder agrees not to make changes in the list of subcontractors without the written consent of the Departmental Representative. The Bidder understands that for each part of the work, if more than one subcontractor is named, or no subcontractor is named, or, the Bidder fails to state that the work will be done by its own forces where applicable, the bid will be subject to disqualification.

**LIST OF EQUIPMENT**

**LIST OF MATERIALS**



## **Appendix "D"**

### **MAJOR WORKS - GENERAL CONDITIONS**



**MAJOR WORKS – GENERAL CONDITIONS**

Page 1 of 62

**MAJOR WORKS GENERAL CONDITIONS FORM AAFC 5321:**

Revision Date

GC1	GENERAL PROVISIONS	2016-05-01
GC2	ADMINISTRATION OF THE CONTRACT	2016-05-01
GC3	EXECUTION AND CONTROL OF THE WORK	2016-01-01
GC4	PROTECTIVE MEASURES	Original
GC5	TERMS OF PAYMENT	2016-05-01
GC6	DELAYS AND CHANGES IN THE WORK	Original
GC7	DEFAULT, SUSPENSION OR TERMINATION OF CONTRACT	Original
GC8	DISPUTE RESOLUTION	2016-05-01
GC9	CONTRACT SECURITY	2016-05-01
GC10	INSURANCE	<b>Original</b>

**GC1 GENERAL PROVISIONS**

- GC1.1 INTERPRETATION
  - GC1.1.1 Headings and References
  - GC1.1.2 Terminology
  - GC1.1.3 Application of Certain Provisions
  - GC1.1.4 Substantial Performance
  - GC1.1.5 Completion
- GC1.2 CONTRACT DOCUMENTS
  - GC1.2.1 General
  - GC1.2.2 Order of Precedence
  - GC1.2.3 Security and Protection of Documents and Work
- GC1.3 STATUS OF THE CONTRACTOR
- GC1.4 RIGHTS AND REMEDIES
- GC1.5 TIME OF THE ESSENCE
- GC1.6 INDEMNIFICATION BY THE CONTRACTOR
- GC1.7 INDEMNIFICATION BY CANADA
- GC1.8 LAWS, PERMITS AND TAXES
- GC1.9 WORKERS' COMPENSATION
- GC1.10 NATIONAL SECURITY
- GC1.11 UNSUITABLE WORKERS
- GC1.12 PUBLIC CEREMONIES AND SIGNS
- GC1.13 CONFLICT OF INTEREST
- GC1.14 AGREEMENTS AND AMENDMENTS
- GC1.15 SUCCESSION
- GC1.16 ASSIGNMENT
- GC1.17 NO BRIBE
- GC1.18 CERTIFICATION - CONTINGENCY FEES
- GC1.19 INTERNATIONAL SANCTIONS
- GC1.20 INTEGRITY PROVISIONS – CONTRACT
- GC1.21 CODE OF CONDUCT FOR PROCUREMENT - CONTRACT

**GC1.1 (2016-05-01) INTERPRETATION**

**GC1.1.1 Headings and References**

- 1) The headings in the contract documents, other than those in the drawings and specifications, form no part of the Contract but are inserted for convenience of reference only.
- 2) A reference made to a part of the Contract by means of numbers preceded by letters is a reference to the particular part of the Contract that is identified by that combination of letters and numbers and to any other part of the Contract referred to therein.
- 3) A reference to a paragraph or subparagraph followed by an identifying number, letter or combination thereof is, unless specifically stated otherwise, a reference to the paragraph or subparagraph that forms part of the clause within which the reference is made.

**GC1.1.2 Terminology**

In the Contract, unless the context otherwise requires:

“Administrative Agreement”

is a negotiated agreement with the Minister of AAFC as provided for in the Ineligibility and Suspension Policy.

**“Affiliate”**

is a person, including, but not limited to, organizations, bodies corporate, societies, companies, firms, partnerships, associations of persons, parent companies or subsidiaries, whether partly or wholly-owned, as well as individuals, directors, officers and key employees if:

- (i) one controls or has the power to control the other, or
- (ii) a third party has the power to control both.

**"Applicable Taxes"**

means the Goods and Services Tax (GST), the Harmonized Sales Tax (HST), and any provincial tax, by law, payable by Canada such as, the Quebec Sales Tax (QST) as of April 1, 2013;

**"Canada", "Crown", "Her Majesty"**

means Her Majesty the Queen in right of Canada;

**"Contract"**

means the contract documents referred to as such therein and every other document specified or referred to in any of them as forming part of the Contract, all as amended by agreement of the parties;

**"Contract Amount"**

means the amount set out in the Contract to be payable to the Contractor for the Work, subject to the terms and conditions of the Contract, exclusive of Applicable Taxes;

**"Contract Security"**

means any security given by the Contractor to Canada in accordance with the Contract;

**"Contractor"**

means the person contracting with Canada to provide or furnish all labour, Material and Plant for the execution of the Work under the Contract, and includes the Contractor's superintendent as designated in writing to Canada.

**"Certificate of Completion"**

means a certificate issued by Canada when the Work reaches Completion;

**"Certificate of Measurement"**

means a certificate issued by Canada certifying the correctness of the final quantities, prices per unit and values of labour, Plant and Material performed, used and supplied by the Contractor for the construction of the part of the Work to which a Unit Price Arrangement applies;

**"Certificate of Substantial Performance"**

means a certificate issued by Canada when the Work reaches Substantial Performance;

**“Control”**

means:

- a) direct control, such as where:
  - (i) a person controls a body corporate if securities of the body corporate to which are attached more than 50 percent of the votes that may be cast to elect directors of the body corporate are beneficially owned by the person and the votes attached to those securities are sufficient, if exercised, to elect a majority of the directors of the body corporate;



- (ii) a person controls a corporation that is organized on a cooperative basis if the person and all of the entities controlled by the person have the right to exercise more than 50 percent of the votes that may be cast at an annual meeting or to elect the majority of the directors of the corporation;
  - (iii) a person controls an unincorporated entity, other than a limited partnership, if more than 50 percent of the ownership interests, however designated, into which the entity is divided are beneficially owned by that person and the person is able to direct the business and affairs of the entity;
  - (iv) the general partner of a limited partnership controls the limited partnership; and
  - (v) a person controls an entity if the person has any direct or indirect influence that, if exercised, would result in control in fact of the entity.
- b) deemed control, such as where:  
a person who controls an entity is deemed to control any entity that is controlled, or deemed to be controlled, by the entity
- c) indirect control, such as where:  
a person is deemed to control, within the meaning of paragraph (a) or (b), an entity where the aggregate of:
- (i) any securities of the entity that are beneficially owned by that person, and
  - (ii) any securities of the entity that are beneficially owned by any entity controlled by that person

is such that, if that person and all of the entities referred to in paragraph (c)(ii) that beneficially own securities of the entity were one person, that person would control the entity.

**"Departmental Representative"**

means the person designated in the Contract, or by written notice to the Contractor, to act as the Departmental Representative for the purposes of the Contract, and includes a person, designated and authorized in writing by the Departmental Representative to the Contractor;

**"herein", "hereby", "hereof", "hereunder"**

and similar expressions refer to the Contract as a whole and not to any particular section or part thereof;

**"Ineligibility"**

means a person not eligible to contract with Canada;

**"Lump Sum Arrangement"**

means that part of the Contract that prescribes a lump sum as payment for performance of the Work to which it relates;

**"Material"**

includes all commodities, articles, machinery, equipment, fixtures and things required to be furnished in accordance with the Contract for incorporation into the Work;

**"person"**

also includes, unless there is an express stipulation in the Contract to the contrary, any partnership, proprietorship, firm, joint venture, consortium or corporation;

**"Plant"**

includes all tools, implements, machinery, vehicles, structures, equipment, articles and things that are necessary for the performance of the Contract, other than Material and those tools customarily provided by a tradesperson in practicing a trade;

**"Subcontractor"**

means a person having a direct contract with the Contractor, subject to GC3.6

**"Subcontracting"**, to perform a part or parts of the Work, or to supply Material customized for the Work;

**"Superintendent"**

means the employee or representative of the Contractor designated by the Contractor to act pursuant to GC2.6, "Superintendent";

**"Supplementary Conditions"**

means the part of the Contract that amends or supplements the General Conditions;

**"Supplier"**

means a person having a direct contract with the Contractor to supply Plant or Material not customized for the Work;

**"Suspension"**

means a determination of temporary ineligibility by the Minister of AAFC;

**"Total Estimated Cost", "Revised Estimated Cost", "Increase (Decrease)"**

on Page 1 of the Contract or Contract Amendment means an amount used for internal administrative purposes only that comprises the Contract Amount, or the revised Contract Amount, or the amount that would increase or decrease the Contract Amount and the Applicable Taxes as evaluated by the Contracting Authority, and does not constitute tax advice on the part of Canada;

**"Unit Price Arrangement"**

means that part of the Contract that prescribes the product of a price per unit of measurement multiplied by a number of units of measurement for performance of the Work to which it relates;

**"Unit Price Table"**

means the table of prices per unit set out in the Contract;

**"Work"**

means, subject only to any express stipulation in the Contract to the contrary, everything that is necessary to be done, furnished or delivered by the Contractor to perform the Contract in accordance with the contract documents; and

**"Working Day"**

means a day other than a Saturday, Sunday, or a statutory holiday that is observed by the construction industry in the area of the place of the Work.

**GC1.1.3 Application of Certain Provisions**

- 1) Any provisions of the Contract that are expressly stipulated to be applicable only to a Unit Price Arrangement are not applicable to any part of the Work to which a Lump Sum Arrangement applies.
- 2) Any provisions of the Contract that are expressly stipulated to be applicable only to a Lump Sum Arrangement are not applicable to any part of the Work to which a Unit Price Arrangement applies.

#### **GC1.1.4 Substantial Performance**

- 1) The Work shall be considered to have reached Substantial Performance when
  - a) the Work or a substantial part thereof has passed inspection and testing and is, in the opinion of Canada, ready for use by Canada or is being used for the intended purposes; and
  - b) the Work is, in the opinion of Canada, capable of completion or correction at a cost of not more than
    - (i) 3 percent of the first \$500,000;
    - (ii) 2 percent of the next \$500,000; and
    - (iii) 1 percent of the balanceof the Contract Amount at the time this cost is calculated.
- 2) Where the Work or a substantial part thereof is ready for use or is being used for the purposes intended and
  - a. the remainder of the Work or a part thereof cannot be completed by the time specified in the Contract, or as amended in accordance with GC6.5, "Delays and Extension of Time", for reasons beyond the control of the Contractor; or
  - b. Canada and the Contractor agree not to complete a part of the Work within the specified time;

the cost of that part of the Work that was either beyond the control of the Contractor to complete or Canada and the Contractor have agreed not to complete by the time specified, shall be deducted from the value of the Contract referred to in subparagraph 1)(b) of GC1.1.4 and the said cost shall not form part of the cost of the Work remaining to be done in determining Substantial Performance.

#### **GC1.1.5 Completion**

The Work shall be deemed to have reached Completion when all labour, Plant and Material required have been performed, used or supplied, and the Contractor has complied with the Contract and all orders and directions made pursuant thereto, all to the satisfaction of Canada.

#### **GC1.2 (2016-05-01) CONTRACT DOCUMENTS**

The following discusses contract documents

##### **GC1.2.1 General**

- 1) The contract documents are complementary, and what is required by any one shall be as binding as if required by all.

- 2) References in the contract documents to the singular shall be considered to include the plural as the context requires.
- 3) Nothing contained in the contract documents shall create a contractual relationship between Canada and any Subcontractor or Supplier, their subcontractors or suppliers, or their agents or employees.

**GC1.2.2 Order of Precedence**

- 1) In the event of any discrepancy or conflict in the contents of the following documents, such documents shall take precedence and govern in the following order:
  - a) any amendment or variation of the contract documents that is made in accordance with the General Conditions;
  - b) any amendment issued prior to tender closing;
  - c) Supplementary Conditions;
  - d) General Conditions;
  - e) the duly completed Bid and Acceptance Form when accepted;
  - f) drawings and specifications.

later dates shall govern within each of the above categories of documents.

- 2) In the event of any discrepancy or conflict in the information contained in the drawings and specifications, the following rules shall apply:
  - a) specifications shall govern over drawings;
  - b) dimensions shown in figures on a drawings shall govern where they differ from dimensions scaled from the same drawings; and
  - c) drawings of larger scale govern over those of smaller scale.

**GC1.2.3 Security and Protection of Documents and Work**

- 1) The Contractor shall guard and protect contract documents, drawings, information, models and copies thereof, whether supplied by Canada or the Contractor, against loss or damage from any cause.
- 2) The Contractor shall keep confidential all information provided to the Contractor by or on behalf of Canada in connection with the Work, and all information developed by the Contractor as part of the Work, and shall not disclose any such information to any person without the written permission of Canada, except that the Contractor may disclose to a subcontractor, authorized in accordance with the Contract, information necessary to the performance of a subcontract. This section does not apply to any information that
  - a) is publicly available from a source other than the Contractor; or

- b) is or becomes known to the Contractor from a source other than Canada, except any source that is known to the Contractor to be under an obligation to Canada not to disclose the **information**.
- 3) When the Contract, the Work, or any information referred to in paragraph 2) is identified as top secret, secret, confidential, or protected by Canada, the Contractor shall, at all times, take all measures reasonably necessary for the safeguarding of the material so identified, including such measures as may be further specified elsewhere in the Contract or provided, in writing, from time to time by Canada.
- 4) Without limiting the generality of paragraphs 2) and 3) of GC1.2.3, when the Contract, the Work, or any information referred to in paragraph 2) is identified as top secret, secret, confidential, or protected by Canada, Canada shall be entitled to inspect the Contractor's premises and the premises of its subcontractors or suppliers and any other person at any tier, for security purposes at any time during the term of the Contract, and the Contractor shall comply with, and ensure that any such subcontractors or suppliers comply with all written instructions issued by Canada dealing with the material so identified, including any requirement that employees of the Contractor and its subcontractors and suppliers and any other person at any tier execute and deliver declarations relating to reliability screenings, security clearances and other procedures.
- 5) The Contractor shall safeguard the Work and the Contract, the specifications, drawings and any other information provided by Canada to the Contractor, and shall be liable to Canada for any loss or damage from any causes.

**GC1.3 STATUS OF THE CONTRACTOR**

- 1) The Contractor is engaged under the Contract as an independent contractor.
- 2) The Contractor, its subcontractors and suppliers and any other person at any tier and their employees are not engaged by the Contract as employees, servants or agents of Canada.
- 3) For the purposes of the contract the Contractor shall be solely responsible for any and all payments and deductions required to be made by law including those required for Canada or Quebec Pension Plans, Employment Insurance, Worker's Compensation, provincial health or insurance plans, and Income Tax.

**GC1.4 (2016-05-01) RIGHTS AND REMEDIES**

- 1) Except as expressly provided in the Contract, the duties and obligations imposed by the Contract and the rights and remedies available thereunder shall be in addition to and not a limitation of any duties, obligations, rights, and remedies otherwise imposed or available by law.

**GC1.5 (2016-05-01) TIME OF THE ESSENCE**

- 1) Time is of the essence of the Contract.

**GC1.6 INDEMNIFICATION BY THE CONTRACTOR**

- 1) The Contractor shall pay all royalties and patent fees required for the performance of the Contract and, at the Contractor's expense, shall defend all claims, actions or proceedings

against Canada charging or claiming that the Work or any part thereof provided or furnished by the Contractor to Canada infringes any patent, industrial design, copyright trademark, trade secret or other proprietary right enforceable in Canada.

- 2) The Contractor shall indemnify and save Canada harmless from and against all claims, demands, losses, costs, damages, actions, suits, or proceedings by any third party, brought or prosecuted and in any manner based upon, arising out of, related to, occasioned by, or attributable to the activities of the Contractor, its subcontractors and suppliers and any other person at any tier, in performing the Work.
- 3) For the purposes of paragraph 2) of GC1.6, "activities" means any act improperly carried out, any omission to carry out an act and any delay in carrying out an act.

#### **GC1.7 (2016-05-01) INDEMNIFICATION BY CANADA**

- 1) Subject to the [Crown Liability and Proceedings Act](#), the [Patent Act](#), and any other law that affects Canada's rights, powers, privileges or obligations, Canada shall indemnify and save the Contractor harmless from and against all claims, demands, losses, costs, damage, actions, suits or proceedings arising out of the Contractor's activities under the Contract that are directly attributable to
  - a) a lack of or a defect in Canada's title to the Work site if owned by Canada, whether real or alleged; or
  - b) an infringement or an alleged infringement by the Contractor of any patent of invention or any other kind of intellectual property occurring while the Contractor was performing any act for the purposes of the Contract employing a model, plan or design or any other thing related to the Work that was supplied by Canada to the Contractor.

#### **GC1.8 (2016-05-01) LAWS, PERMITS AND TAXES**

- 1) The Contractor shall comply with all federal, provincial and municipal laws and regulations applicable to the performance of the Work or any part thereof including, without limitation, all laws concerning health and the protection of the environment, and shall require compliance therewith by all of its subcontractors and suppliers at any tier as if the Work were being performed for an owner other than Canada. The Contractor shall furnish evidence of compliance with such laws and regulations to Canada at such times as Canada may reasonably request.
- 2) Unless stipulated otherwise in the Contract, the Contractor shall obtain and maintain all permits, certificates, licences, registrations and authorizations required for the lawful performance of the Work.
- 3) Prior to the commencement of the Work at the site, the Contractor shall tender to a municipal authority an amount equal to all fees and charges that would be lawfully payable to that municipal authority in respect of building permits as if the Work were being performed for an owner other than Canada.
- 4) Within 10 days of making a tender pursuant to paragraph 3) of GC1.8, the Contractor shall notify Canada of the amount properly tendered and whether or not the municipal authority has accepted that amount.

- 5) If the municipal authority has not accepted the amount tendered, the Contractor shall pay that amount to Canada within 6 days after the time stipulated in paragraph 4) of GC1.8.
- 6) For the purposes of this clause, "municipal authority" means any authority that would have jurisdiction respecting permission to perform the Work if the owner were not Canada.
- 7) Notwithstanding the residency of the Contractor, the Contractor shall pay any applicable tax arising from or related to the performance of the Work under the Contract.
- 8) In accordance with the Statutory Declaration referred to in paragraph 4) of GC5.5, "Substantial Performance of the Work", a Contractor who has neither residence nor place of business in the province or territory in which work under the Contract is being performed shall provide Canada with proof of registration with the provincial sales tax authorities in the said province.
- 9) For the purpose of the payment of any Applicable Taxes or the furnishing of security for the payment of any Applicable Taxes arising from or related to the performance of the Work, and notwithstanding the provision that all Material, Plant and interest of the Contractor in all real property, licences, powers and privileges, become the property of Canada after the time of purchase in accordance with GC3.10, "Material Plant and Real Property Become Property of Canada", the Contractor shall be liable, as a user or consumer, for the payment or for the furnishing of security for the payment of any Applicable Taxes payable, at the time of the use or consumption of that Material, Plant or interest of the Contractor in accordance with the relevant legislation.
- 10) Federal government departments and agencies are required to pay Applicable Taxes.
- 11) Applicable Taxes will be paid by Canada as provided in the request for payment. It is the sole responsibility of the Contractor to charge Applicable Taxes at the correct rate in accordance with applicable legislation. The Contractor agrees to remit to appropriate tax authorities any amounts of Applicable Taxes paid or due.
- 12) The Contractor is not entitled to use Canada's exemptions from any tax, such as provincial sales taxes, unless otherwise specified by law. The Contractor must pay applicable provincial sales tax, ancillary taxes, and any commodity tax, on taxable goods or services used or consumed in the performance of the Contract (in accordance with applicable legislation), including for material incorporated into real property.
- 13) In those cases where Applicable Taxes, customs duties, and excise taxes are included in the Contract Amount, the Contract Amount will be adjusted to reflect any increase, or decrease, of Applicable Taxes, customs duties, and excise taxes that will have occurred between bid submission and contract award. However, there will be no adjustment for any change to increase the Contract Amount if public notice of the change was given before bid submission date in sufficient detail to have permitted the Contractor to calculate the effect of the change.
- 14) Tax Withholding of 15 Percent – Canada Revenue Agency  
Pursuant to the [Income Tax Act](#), 1985, c. 1 (5th Supp.) and the [Income Tax Regulations](#), Canada must withhold 15 percent of the amount to be paid to the Contractor in respect of services provided in Canada if the Contractor is not a resident of Canada, unless the Contractor obtains a valid waiver from the Canada Revenue Agency. The amount withheld will be held on account for the Contractor in respect to any tax liability which may be owed to Canada.

#### GC1.9 WORKERS' COMPENSATION

- 1) Prior to commencement of Work, at the time of Substantial Performance of the Work, and prior to issuance of the Certificate of Completion, the Contractor shall provide evidence of compliance with workers' compensation legislation applicable to the place of the Work, including payments due thereunder.
- 2) At any time during the term of the Contract, when requested by Canada, the Contractor shall provide such evidence of compliance by the Contractor, its subcontractors and any other person at any tier and any other person performing part of the Work who is required to comply with such legislation.

**GC1.10 NATIONAL SECURITY**

- 1) If Canada determines that the Work is of a class or kind that involves national security, Canada may order the Contractor to
  - (a) provide Canada with any information concerning persons employed or to be employed by the Contractor for purposes of the Contract; and
  - (b) remove any person from the site of the Work if, in the opinion of Canada, that person may be a risk to the national security;and the Contractor shall comply with the order.
- 2) In all contracts with persons who are to be employed in the performance of the Contract, the Contractor shall make provision for the performance of any obligation that may be imposed upon the Contractor under paragraph 1) of GC1.10.

**GC1.11 (2016-05-01) UNSUITABLE WORKERS**

- 1) Canada shall instruct the Contractor to remove from the site of the Work any person employed by the Contractor for purposes of the Contract who, in the opinion of Canada, is incompetent or is guilty of improper conduct, and the Contractor shall not permit a person who has been removed to return to the site of the Work.

**GC1.12 PUBLIC CEREMONIES AND SIGNS**

- 1) The Contractor shall not permit any public ceremony in connection with the Work without the prior consent of Canada.
- 2) The Contractor shall not erect nor permit the erection of any sign or advertising on the Work or its site without the prior consent of Canada.

**GC1.13 (2016-05-01) CONFLICT OF INTEREST**

- 1) It is a term of the Contract that no individual, for whom the post-employment provisions of the Conflict of Interest and Post-Employment Code for Public Office Holders or the Values and Ethics Code for the Public Service apply, shall derive a direct benefit from the Contract unless that individual is in compliance with the applicable post-employment provisions.

**GC1.14 AGREEMENTS AND AMENDMENTS**



- 1) The Contract constitutes the entire and sole agreement between the parties with respect to the subject matter of the Contract and supersedes all previous negotiations, communications and other agreements, whether written or oral, relating to it, unless they are incorporated by reference in the Contract. There are no terms, covenants, representations, statements or conditions binding on the parties other than those contained in the Contract.
- 2) The failure of either party at any time to require performance by the other party of any provision hereof shall not affect the right thereafter to enforce such provision. Nor shall the waiver by either party of any breach of any covenant, term or condition hereof be taken to be held to be a waiver of any further breach of the same covenant, term or condition.
- 3) The Contract may be amended only as provided for in the Contract.

**GC1.15 (2016-05-01) SUCCESSION**

- 1) The Contract shall inure to the benefit of and be binding upon the parties hereto and their lawful heirs, executors, administrators, successors and, subject to GC1.16, "Assignment", permitted assigns.

**GC1.16 (2016-05-01) ASSIGNMENT**

- 1) The Contractor shall not make any assignment of the Contract, either in whole or in part, without the written consent of Canada.

**GC1.17 (2016-05-01) NO BRIBE**

- 1) The Contractor represents and covenants that no bribe, gift, benefit, nor other inducement has been nor shall be paid, given, promised or offered directly or indirectly to any official or employee of Canada or to a member of the family of such a person, with a view to influencing the entry into the Contract or the administration of the Contract.

**GC1.18 CERTIFICATION - CONTINGENCY FEES**

- 1) In this clause
  - (a) "contingency fee" means any payment or other compensation that is contingent upon or is calculated upon the basis of a degree of success in soliciting or obtaining a Government contract or negotiating the whole or any part of its terms;
  - (b) "employee" means a person with whom the Contractor has an employer/employee relationship; and
  - (c) "person" includes an individual or a group of individuals, a corporation, a partnership, an organization and an association and, without restricting the generality of the foregoing, includes any individual who is required to file a return with the registrar pursuant to section 5 of the [Lobbying Act](#) R.S.C. 1985 c.44 (4th Supplement) as the same may be amended from time to time.
- 2) The Contractor certifies that it has not directly or indirectly paid nor agreed to pay and covenants that it shall not directly or indirectly pay nor agree to pay a contingency fee for the solicitation, negotiation or obtaining of the Contract to any person other than an employee acting in the normal course of the employee's duties.

- 3) All accounts and records pertaining to payments of fees or other compensation for the solicitation, obtaining or negotiation of the Contract shall be subject to the accounts and audit provisions of the Contract.
- 4) If the Contractor certifies falsely under this section or is in default of the obligations contained therein, Canada may either take the Work out of the Contractor's hands in accordance with the provisions of the Contract or recover from the Contractor by way of reduction to the Contract Amount or otherwise, the full amount of the contingency fee.

#### **GC1.19 INTERNATIONAL SANCTIONS**

- 1) Persons and companies in Canada, and Canadians outside of Canada are bound by economic sanctions imposed by Canada. As a result, the Government of Canada cannot accept delivery of goods or services that originate, either directly or indirectly, from the countries or persons subject to **economic sanctions** (<http://www.international.gc.ca/sanctions/index.aspx?lang=eng>)
- 2) It is a condition of the Contract that the Contractor not supply to the Government of Canada any goods or services which are subject to economic sanctions.
- 3) By law, the Contractor must comply with changes to the regulations imposed during the life of the Contract. During the performance of the Contract should the imposition of sanctions against a country or person or the addition of a good or service to the list of sanctioned goods or services cause an impossibility of performance for the Contractor, the Contractor may request that the Contract be terminated in accordance with GC7.3 TERMINATION OF CONTRACT.

#### **GC1.20 (2016-05-01) INTEGRITY PROVISIONS – CONTRACT**

- 1) The Ineligibility and Suspension Policy (the "Policy") and all related Directives are incorporated into, and form a binding part of the Contract. The Contractor must comply with the provisions of the Policy and Directives, which can be found on Public Works and Government Services Canada's website at Ineligibility and Suspension Policy. (<http://www.tpsgc-pwgsc.gc.ca/ci-if/politique-policy-eng.html>).

#### **GC1.21 (2016-05-01) CODE OF CONDUCT FOR PROCUREMENT - CONTRACT**

- 1) The Contractor agrees to comply with the Code of Conduct (<http://www.tpsgc-pwgsc.gc.ca/app-acq/cndt-cndct/contexte-context-eng.html>) for Procurement and to be bound by its terms for the period of the Contract.

**GC2 ADMINISTRATION OF THE CONTRACT**

- GC2.1 DEPARTMENTAL REPRESENTATIVE'S AUTHORITY
- GC2.2 INTERPRETATION OF CONTRACT
- GC2.3 NOTICES
- GC2.4 SITE MEETINGS
- GC2.5 REVIEW AND INSPECTION OF WORK
- GC2.6 SUPERINTENDENT
- GC2.7 NON-DISCRIMINATION IN HIRING AND EMPLOYMENT OF LABOUR
- GC2.8 ACCOUNTS AND AUDITS

**GC2.1 (2016-05-01) DEPARTMENTAL REPRESENTATIVE'S AUTHORITY**

**"Technical Authority" shall be recognized as the Departmental representative and designated at time of award of contract and shall perform the following:**

- a) **is responsible for all matters concerning the technical content of the work under the contract;**
- b) **authorized to issue notices, instructions, and changes within the scope of the Work, relevant to the contract.**
- c) **accept on behalf of Canada any notice, order or other communication from the contractor relating to the Work**
- d) **within a reasonable time, review and respond to submissions made by the Contractor in accordance with the requirements of the Contract**

**The** technical authority has no authority to authorize changes to the Contract terms and conditions of the Contract.

"Contracting Authority" shall be recognized as the authority delegated by the Minister of AAFC to enter into contracts, amend the contracts and is responsible for all matters concerning and interpretation of the terms and conditions of the Contract.

The contracting authority is responsible for the management of the Contract and any changes to the Contract terms **and conditions must be authorized in writing by the Contracting Authority.**

**GC2.2 INTERPRETATION OF CONTRACT**

- 1) If, at any time before Canada has issued a Certificate of Completion, any question arises between the parties about whether anything has been done as required by the Contract or about what the Contractor is required by the Contract to do, and in particular but without limiting the generality of the foregoing, about
  - (a) the meaning of anything in the drawings and specifications;
  - (b) the meaning to be given to the drawings and specifications in case of any error therein, omission therefrom, or obscurity or discrepancy in their wording or intention;

- (c) whether or not the quality or quantity of any Material or workmanship supplied or proposed to be supplied by the Contractor meets the requirements of the Contract;
- (d) whether or not the labour, Plant or Material performed, used and supplied by the Contractor for performing the Work and carrying out the Contract are adequate to ensure that the Work shall be performed in accordance with the Contract and that the Contract shall be carried out in accordance with its terms;
- (e) what quantity of any of the Work has been completed by the Contractor; or
- (f) the timing and scheduling of the various phases of the performance of the Work as specified in the Contract;

the question shall be decided, subject to the provisions of GC8 DISPUTE RESOLUTION, by Canada.

- 2) The Contractor shall perform the Work in accordance with any decisions of Canada that are made under paragraph 1) of GC2.2 and in accordance with any consequential directions given by Canada.
- 3) If the Contractor fails to comply with any instruction or direction issued by Canada pursuant to the Contract, Canada may employ such methods as Canada deems advisable to do what the Contractor failed to do, and the Contractor shall, on demand, pay Canada an amount that is equal to the aggregate of all costs, expenses and damages incurred or sustained by Canada by reason of the Contractor's failure to comply with such instruction or direction, including the cost of any methods employed by Canada in doing what the Contractor failed to do.

**GC2.3 NOTICES**

- 1) Subject to paragraph 3) of GC2.3, any notice, order or other communication may be given in any manner, and if required to be in writing, shall be addressed to the party to whom it is intended at the address in the Contract or at the last address of which the sender has received written notice in accordance with this section.
- 2) Any notice, order or other communication given in writing in accordance with paragraph 1) of GC2.3 shall be deemed to have been received by either party
  - (a) if delivered personally, on the day that it was delivered;
  - (b) if forwarded by mail, on the earlier of the day it was received or the sixth day after it was mailed; and
  - (c) if forwarded by facsimile or electronic mail, 24 hours after it was transmitted.
- 3) A notice given under GC7.1 TAKING THE WORK OUT OF THE CONTRACTOR'S HANDS, GC7.2 SUSPENSION OF WORK, and GC7.3 TERMINATION OF CONTRACT shall be given in writing and, if delivered personally, shall be delivered, if the Contractor is a sole proprietor, to the Contractor or, if the Contractor is a partnership or corporation, to an officer thereof.

**GC2.4 (2016-05-01) SITE MEETINGS**

- 1) In consultation with Canada, the Contractor shall arrange site meetings at regular intervals, with all involved parties who are to attend, in order to ensure, among other things, the proper co-ordination of the Work.

**GC2.5 REVIEW AND INSPECTION OF WORK**

- 1) Canada shall review the Work to determine if it is proceeding in conformity with the Contract and to record the necessary data to make an assessment of the value of Work completed. Canada shall measure and record the quantities of labour, Plant and Material performed, used or supplied by the Contractor in performing the Work or any part thereof that is subject to a Unit Price Arrangement and, on request, shall inform the Contractor of those measurements, and permit the Contractor to inspect any records pertaining thereto.
- 2) Canada shall reject Work or Material which in Canada's opinion does not conform to the requirements of the Contract, and shall require inspection or testing of Work, whether or not such Work is fabricated, installed, or completed. If such Work is not in accordance with the requirements of the Contract, the Contractor shall correct the Work and shall pay Canada, on demand, all reasonable costs and expenses that were incurred by Canada in having the examination performed.
- 3) The Contractor shall provide Canada with access to the Work and its site at all times, and at all times shall provide sufficient, safe, and proper facilities for the review and inspection of the Work by persons authorized by Canada and any representatives of those authorities having jurisdiction. If parts of the Work are in preparation at locations other than the site of the Work, Canada shall be given access to such Work whenever it is in progress.
- 4) The Contractor shall furnish Canada with such information respecting the performance of the Contract as Canada may require, and render every possible assistance to enable Canada to verify that the Work is performed in accordance with the Contract, carry out any other duties and exercise any powers in accordance with the Contract.
- 5) If Work is designated for tests, inspections, or approvals in the Contract or by Canada's instructions, or by laws or ordinances of the place of the Work, the Contractor shall give Canada reasonable notice of when such Work shall be ready for review and inspection. The Contractor shall arrange for and shall give Canada reasonable notice of the date and time of inspections, tests or approvals.
- 6) If the Contractor covers, or permits to be covered, Work that has been designated for tests, inspections or approvals before such tests, inspections or approvals are made, completed or given, the Contractor shall, if so directed by Canada, uncover such Work, have the inspections, tests or approvals satisfactorily made, completed or given and make good the covering of the Work at the Contractor's expense.

**GC2.6 SUPERINTENDENT**

- 1) Prior to commencing the Work, the Contractor shall designate a Superintendent and shall notify Canada of the name, address and telephone number of the Superintendent. The Contractor shall keep the Superintendent at the Work site during working hours until the Work has reached completion.
- 2) The Superintendent shall be in full charge of the operations of the Contractor during the performance of the Work and shall be authorized to accept on behalf of the Contractor any notice, order or other communication given to the Superintendent or the Contractor relating to the Work.

- 3) Upon request of Canada, the Contractor shall remove any Superintendent who, in the opinion of Canada, is incompetent or has been guilty of improper conduct, and shall forthwith designate another Superintendent who is acceptable to Canada.
- 4) The Contractor shall not substitute a Superintendent without the written consent of Canada. If a Superintendent is substituted without such consent, Canada shall be entitled to refuse to issue any documentation or certification relating to progress payments, Substantial Performance or Completion of the Work until the Superintendent has returned to the Work site or another Superintendent who is acceptable to Canada has been substituted.

#### **GC2.7 (2016-05-01) NON-DISCRIMINATION IN HIRING AND EMPLOYMENT OF LABOUR**

- 1) For the purposes of this clause, "persons" include the Contractor, its subcontractors and suppliers at any tier and their respective employees, agents, licensees or invitees and any other individual involved in the performance of the Work or granted access to the Work site. A "person" includes any partnership, proprietorship, firm, joint venture, consortium and corporation.
- 2) Without restricting the provisions of paragraph 3) of GC2.6, "Superintendent", the Contractor shall not refuse to employ and shall not discriminate in any manner against any person because
  - a) of that person's race, national or ethnic origin, colour, religion, age, sex, sexual orientation, marital status, disability, conviction for which a pardon has been granted, or family status;
  - b) of the race, national or ethnic origin, colour, religion, age, sex, sexual orientation, marital status, disability, conviction for which a pardon has been granted, or family status of any person having a relationship or association with that person, or
  - c) a complaint has been made or information has been given in respect of that person relating to an alleged failure by the Contractor to comply with subparagraph (a) or (b).
- 3) Within two working days immediately following receipt of a written complaint pursuant to paragraph 2) of GC2.7, the Contractor shall
  - a) cause to have issued a written direction to the person or persons named by the complainant to cease all actions that form the basis of the complaint;
  - b) forward a copy of the complaint to Canada by registered mail or courier service.
- 4) Within 24 hours immediately following receipt of a direction from Canada to do so, the Contractor shall cause to have removed from the site of the Work and from the performance of Work under the Contract, any person or persons whom Canada believes to be in breach of the provisions of paragraph 2) of GC2.7.
- 5) No later than 30 days after receipt of the direction referred to in paragraph 4) of GC2.7, the Contractor shall cause the necessary action to be commenced to remedy the breach described in the direction.
- 6) If a direction is issued pursuant to paragraph 4) of GC2.7, Canada may withhold from monies that are due and payable to the Contractor or setoff pursuant to GC5.9, "Right of Setoff", whichever is applicable, an amount representing the sum of the costs and payment referred to in paragraph 8) of GC2.7.

- 7) If the Contractor fails to proceed in accordance with paragraph 5) of GC2.7, Canada shall take the necessary action to have the breach remedied, and shall determine all supplementary costs incurred by Canada as a result.
- 8) Canada may make a payment directly to the complainant from monies that are due and payable to the Contractor upon receipt from the complainant of
  - a) a written award issued pursuant to the federal **Commercial Arbitration Act**, R.S. 1985, c. 17 (2nd Supp.);
  - b) a written award issued pursuant to the **Canadian Human Rights Act**, R.S. 1985, c. H-6;
  - c) a written award issued pursuant to provincial or territorial human rights legislation; or
  - d) a judgement issued by a court of competent jurisdiction.
- 9) If Canada is of the opinion that the Contractor has breached any of the provisions of this clause, Canada may take the Work out of the Contractor's hands pursuant to GC7.1, "Taking the Work out of the Contractor's Hands".
- 10) Subject to paragraph 7) of GC3.6, "Subcontracting", the Contractor shall ensure that the provisions of this clause are included in all agreements and contracts entered into as a consequence of the Work.

#### **GC2.8 (2016-05-01) ACCOUNTS AND AUDITS**

- 1) The Contractor shall, in addition to the requirements expressed in paragraph 6) of GC3.4, "Execution of the Work", maintain full records of the Contractor's estimated and actual cost of the Work together with all tender calls, quotations, contracts, correspondence, invoices, receipts and vouchers relating thereto, and shall make them available on request to audit and inspection by Canada and the Deputy Receiver General for Canada or by persons designated to act on behalf of either or both of them.
- 2) The Contractor shall allow any of the persons referred to in paragraph 1) of GC2.8 to make copies of and take extracts from any of the records and material, and shall furnish such persons or entities with any information those persons or entities may require from time to time in connection with such records and material.
- 3) The Contractor shall maintain and keep the records intact until the expiration of six (6) years after the date that a Certificate of Completion has been issued or until the expiration of such other period of time as Canada may direct.
- 4) The Contractor shall cause all subcontractors at any tier and all other persons directly or indirectly controlled by or affiliated with the Contractor and all persons directly or indirectly having control of the Contractor to comply with the requirements of this clause as if they were the Contractor.

**GC3 EXECUTION AND CONTROL OF THE WORK**

- GC3.1 PROGRESS SCHEDULE
- GC3.2 ERRORS AND OMISSIONS
- GC3.3 CONSTRUCTION SAFETY
- GC3.4 EXECUTION OF THE WORK
- GC3.5 MATERIAL
- GC3.6 SUBCONTRACTING
- GC3.7 CONSTRUCTION BY OTHER CONTRACTORS OR WORKERS
- GC3.8 LABOUR
- GC3.9 TRUCK HAULAGE RATES (CANCELLED)
- GC3.10 MATERIAL, PLANT AND REAL PROPERTY BECOME PROPERTY OF CANADA
- GC3.11 DEFECTIVE WORK
- GC3.12 CLEANUP OF SITE
- GC3.13 WARRANTY AND RECTIFICATION OF DEFECTS IN WORK

**GC3.1 (2016-05-01) PROGRESS SCHEDULE**

The Contractor shall

- a) prepare and submit to Canada, prior to the submission of the Contractor's first progress claim, a progress schedule in accordance with the requirements set out in the Contract;
- b) monitor the progress of the Work relative to the schedule and update the schedule as stipulated by the contract documents;
- c) advise Canada of any revisions to the schedule required as the result of any extension of time for completion of the Contract that was approved by Canada; and
- d) prepare and submit to Canada, at the time of issuance of a Certificate of Substantial Performance, an update of any schedule clearly showing a detailed timetable that is acceptable to Canada for the completion of any unfinished Work and the correction of all listed defects.

**GC3.2 (2016-05-01) ERRORS AND OMISSIONS**

- 1) The Contractor shall report promptly to Canada any errors, discrepancies, or omissions the Contractor may discover when reviewing the contract documents. In making a review, the Contractor does not assume any responsibility to Canada for the accuracy of the review. The Contractor shall not be liable for damage or costs resulting from such errors, discrepancies, or omissions in the contract documents prepared by or on behalf of Canada that the Contractor did not discover.

**GC3.3 CONSTRUCTION SAFETY**

- 1) Subject to GC3.7 CONSTRUCTION BY OTHER CONTRACTORS OR WORKERS, the Contractor shall be solely responsible for construction safety at the place of the Work and for initiating, maintaining and supervising all safety precautions and programs in connection with the performance of the Work. In any emergency, the Contractor shall either stop the Work,



make changes or order extra work to ensure the safety of life and the protection of the Work and neighbouring property.

- 2) Prior to commencing the Work, the Contractor shall notify the authorities having jurisdiction for construction safety at the site of the Work with respect to the intended commencement of the Work, and shall provide such authority with whatever additional information may be required by that authority.

### **GC3.4 EXECUTION OF THE WORK**

- 1) The Contractor shall perform, use or supply and pay for, all labour, Plant, Material, tools, construction machinery and equipment, water, heat, light, power, transportation and other facilities and services necessary for the performance of the Work in accordance with the Contract.
- 2) The Contractor shall, at all times, perform the Work in a proper, diligent and expeditious manner as is consistent with construction industry standards and in accordance with the progress schedule prepared pursuant to GC3.1 PROGRESS SCHEDULE and shall provide sufficient personnel to fulfil the Contractor's obligations in accordance with that schedule.
- 3) Subject to paragraph 4) of GC3.4, the Contractor shall have complete care, custody and control of the Work and shall direct and supervise the Work so as to ensure compliance with the Contract. The Contractor shall be responsible for construction means, methods, techniques, sequences and procedures and for co-ordinating the various parts of the Work.
- 4) When requested in writing by Canada, the Contractor shall make appropriate alterations in the method, Plant or workforce at any time Canada considers the Contractor's actions to be unsafe or damaging to either the Work, existing facilities, persons at the site of the Work or the environment.
- 5) The Contractor shall have sole responsibility for the design, erection, operation, maintenance and removal of temporary structures and other temporary facilities and for the construction methods used in their erection, operation, maintenance and removal. The Contractor shall engage and pay for registered professional engineering personnel, skilled in the appropriate discipline to perform these functions if required by law or by the Contract, and in all cases when such temporary facilities and their methods of construction are of such a nature that professional engineering skill is required to produce safe and satisfactory results.
- 6) The Contractor shall keep at least one copy of current contract documents, submittals, reports, and records of meetings at the site of the Work, in good order and available to Canada.
- 7) Except for any part of the Work that is necessarily performed away from or off the site of the Work, the Contractor shall confine Plant, storage of Material, and operations of employees to limits indicated by laws, ordinances, permits or the contract documents.

### **GC3.5 MATERIAL**

- 1) Unless otherwise specified in the Contract, all Material incorporated in the Work shall be new.
- 2) Subject to paragraph 3) of GC3.5, if a specified reused, refurbished, or recycled item of Material is not available, the Contractor shall apply to Canada to substitute a similar item for the one specified.

- 3) If Canada agrees that the Contractor's application for substitution of a reused, refurbished or recycled item is warranted, and that the substitute item is of acceptable quality and value to that specified and is suitable for the intended purpose, Canada may approve the substitution, subject to the following:
  - (a) the request for substitution shall be made in writing to Canada and shall be substantiated by information in the form of the manufacturer's literature, samples and other data that may be required by Canada;
  - (b) the Contractor shall make the request for substitution in a manner that shall not negatively affect the progress schedule of the Contract and well in advance of the time the item of Material must be ordered;
  - (c) substitution of Material shall be permitted only with the prior written approval of Canada, and any substituted items that are supplied or installed without such approval shall be removed from the site of the Work at the expense of the Contractor, and specified items installed at no additional cost to Canada; and
  - (d) the Contractor shall be responsible for all additional expenses incurred by Canada, the Contractor, its subcontractors and suppliers at any tier due to the Contractor's use of the substitute.

### **GC3.6 SUBCONTRACTING**

- 1) Subject to the provisions of this clause, the Contractor may subcontract any part of the Work but not the whole of the Work.
- 2) The Contractor shall notify Canada in writing of the Contractor's intention to subcontract.
- 3) A notification referred to in paragraph 2) of GC3.6 shall identify the part of the Work and the Subcontractor with whom the Contractor intends to subcontract.
- 4) Canada may for reasonable cause, object to the intended subcontracting by notifying the Contractor in writing within six (6) days of receipt by Canada of a notification referred to in paragraph 2) of GC3.6.
- 5) If Canada objects to a subcontracting, the Contractor shall not enter into the intended subcontract.
- 6) The Contractor shall not change, nor permit to be changed, a Subcontractor engaged by the Contractor, in accordance with this clause, without the written consent of Canada.
- 7) The Contractor shall ensure that all the terms and conditions of the Contract that are of general application shall be incorporated in every other contract issued as a consequence of the Contract, at whatever tier, except those contracts issued solely to suppliers at any tier for the supply of Plant or Material.
- 8) Neither a subcontracting nor Canada's consent to a subcontracting shall be construed to relieve the Contractor from any obligation under the Contract or to impose any liability upon Canada.

### **GC3.7 CONSTRUCTION BY OTHER CONTRACTORS OR WORKERS**

- 1) Canada reserves the right to send other contractors or workers, with or without Plant and Material, onto the site of the Work.
- 2) When other contractors or workers are sent on to the site of the Work, Canada shall
  - (a) enter into separate contracts, to the extent it is possible, with the other contractors under conditions of contract that are compatible with the conditions of the Contract;
  - (b) ensure that the insurance coverage provided by the other contractors is co-ordinated with the insurance coverage of the Contractor as it affects the Work; and
  - (c) take all reasonable precautions to avoid labour disputes or other disputes arising from the work of the other contractors or workers.
- 3) When other contractors or workers are sent on to the site of the Work, the Contractor shall
  - (a) co-operate with them in the carrying out of their duties and obligations;
  - (b) co-ordinate and schedule the Work with the work of the other contractors and workers;
  - (c) participate with other contractors and workers in reviewing their construction schedules when directed to do so;
  - (d) where part of the Work is affected by or depends upon the work of other contractors or workers for its proper execution, promptly report to Canada in writing and prior to proceeding with that part of the Work, any apparent deficiencies in such work. Failure by the Contractor to so report shall invalidate any claims against Canada by reason of the deficiencies in the work of other contractors or workers except those deficiencies that are not then reasonably discoverable; and
  - (e) when designated as being responsible for construction safety at the place of work in accordance with the applicable provincial or territorial laws, carry out its duties in that role and in accordance with those laws.
- 4) If, when entering into the Contract, the Contractor could not have reasonably foreseen nor anticipated the sending of other contractors or workers on to the site of the Work and provided the Contractor
  - (a) incurs extra expense in complying with the requirements of paragraph 3) of GC3.7; and
  - (b) gives Canada written notice of a claim for that extra expense within thirty (30) days of the date that the other contractors or workers were sent onto the Work or its site;

Canada shall pay the Contractor the cost of the extra labour, Plant and Material that was necessarily incurred, calculated in accordance with GC6.4 DETERMINATION OF PRICE.

### **GC3.8 LABOUR**

- 1) To the extent to which they are available, consistent with proper economy and the expeditious carrying out of the Work, the Contractor shall, in the performance of the Work, employ a reasonable number of persons who have been on active service with the Armed Forces of Canada and have been honourably discharged therefrom.

- 2) The Contractor shall maintain good order and discipline among the Contractor's employees and workers engaged in the Work and shall not employ on the site of the Work anyone not skilled in the tasks assigned.

**GC3.9 TRUCK HAULAGE RATES**

CANCELLED

**GC3.10 MATERIAL, PLANT AND REAL PROPERTY BECOME PROPERTY OF CANADA**

- 1) Subject to paragraph 9) of GC1.8 LAWS PERMITS AND TAXES, all Material and Plant and the interest of the Contractor in all real property, licences, powers and privileges purchased, used or consumed by the Contractor for the Work shall, immediately after the time of their purchase, use or consumption be the property of Canada for the purposes of the Work and they shall continue to be the property of Canada
  - (a) in the case of Material, until Canada indicates that the Materials shall not be required for the Work; and
  - (b) in the case of Plant, real property, licences, powers and privileges, until Canada indicates that the interest vested in Canada therein is no longer required for the purposes of the Work.
- 2) Material or Plant, that is the property of Canada by virtue of paragraph 1) of GC3.10, shall not be taken away from the site of the Work nor used nor disposed of except for the purposes of the Work without the written consent of Canada.
- 3) Canada is not liable for loss of nor damage from any cause to the Material or Plant referred to in paragraph 1) of GC3.10, and the Contractor is liable for such loss or damage notwithstanding that the Material or Plant is the property of Canada.

**GC3.11 DEFECTIVE WORK**

- 1) The Contractor shall promptly remove from the site of the Work and replace or re-execute defective Work whether or not the defective Work has been incorporated in the Work and whether or not the defect is the result of poor workmanship, use of defective Material, or damage through carelessness or other act or omission of the Contractor.
- 2) The Contractor, at the Contractor's expense, shall promptly make good other work destroyed or damaged by such removals or replacements.
- 3) If, in the opinion of Canada, it is not expedient to correct defective Work or Work not performed as provided for in the Contract documents, Canada may deduct from the amount otherwise due to the Contractor the difference in value between the Work as performed and that called for by the contract documents.
- 4) The failure of Canada to reject any defective Work or Material shall not constitute acceptance of the defective Work or Material.

**GC3.12 CLEANUP OF SITE**

- 1) The Contractor shall maintain the Work and its site in a tidy condition and free from an accumulation of waste material and debris.
- 2) Before the issue of a Certificate of Substantial Performance, the Contractor shall remove waste material and debris, and all Plant and Material not required for the performance of the remaining Work and, unless otherwise stipulated in the Contract Documents, shall cause the Work and its site to be clean and suitable for occupancy by Canada.
- 3) Before the issue of a Certificate of Completion, the Contractor shall remove all surplus Plant and Materials and any waste products and debris from the site of the Work.
- 4) The Contractor's obligations described in paragraphs 1) to 3) of GC3.12 do not extend to waste products and other debris caused by Canada's servants, or by other contractors and workers referred to in GC3.7 CONSTRUCTION BY OTHER CONTRACTORS OR WORKERS.

**GC3.13 WARRANTY AND RECTIFICATION OF DEFECTS IN WORK**

- 1) Without restricting any warranty or guarantee implied or imposed by law or contained in the Contract, the Contractor shall, at the Contractor's expense
  - (a) rectify and make good any defect or fault that appears in the Work or comes to the attention of Canada with respect to those parts of the Work accepted in connection with the Certificate of Substantial Performance within 12 months from the date of Substantial Performance; and
  - (b) rectify and make good any defect or fault that appears in or comes to the attention of Canada in connection with those parts of the Work described in the Certificate of Substantial Performance within 12 months from the date of the Certificate of Completion.
  - (c) transfer and assign, to Canada, any subcontractor, manufacturer or supplier extended warranties or guarantees implied or imposed by law or contained in the Contract covering periods beyond the 12 months stipulated above. Extended warranties or guarantees referred to herein shall not extend the 12-month period whereby the Contractor, except as may be provided elsewhere in the Contract, must rectify and make good any defect or fault that appears in the Work or comes to the attention of Canada.
  - (d) provide, to Canada prior to the issuance of the Certificate of Completion, a list of all extended warranties and guarantees referred to in paragraph (c) above.
- 2) Canada may direct the Contractor to rectify and make good any defect or fault referred to in paragraph 1) of GC3.13 or covered by any other expressed or implied warranty or guarantee and the Contractor shall rectify and make good such defect within the time stipulated in the direction.
- 3) A direction referred to in paragraph 2) GC3.13 shall be in writing and shall be given to the Contractor in accordance with GC2.3 NOTICES.

**GC4 PROTECTIVE MEASURES**

GC4.1 PROTECTION OF WORK AND PROPERTY

GC4.2 PRECAUTIONS AGAINST DAMAGE, INFRINGEMENT OF RIGHTS, FIRE AND OTHER HAZARDS

GC4.3 MATERIAL, PLANT AND REAL PROPERTY SUPPLIED BY CANADA

GC4.4 CONTAMINATED SITE CONDITIONS

**GC4.1 PROTECTION OF WORK AND PROPERTY**

- 1) The Contractor shall protect the Work and its site against loss or damage from any cause and shall similarly protect all Material, Plant and real property under the Contractor's care, custody and control whether or not such Material, Plant and real property are supplied by Canada to the Contractor.
- 2) The Contractor shall provide all facilities necessary for the purpose of maintaining security, and shall assist any person authorized by Canada to inspect or to take security measures in respect of the Work and its site.
- 3) Canada may direct the Contractor to do such things and to perform such work as Canada considers reasonable and necessary to ensure compliance with or to remedy a breach of paragraphs 1) or 2) of GC4.1, and the Contractor, shall comply with such direction.

**GC4.2 PRECAUTIONS AGAINST DAMAGE, INFRINGEMENT OF RIGHTS, FIRE AND OTHER HAZARDS**

- 1) The Contractor shall do whatever is necessary to ensure that
  - (a) no person, property, right, easement nor privilege is injured, damaged or infringed upon by reasons of the Contractor's activities in performing the Work;
  - (b) pedestrian and other traffic on any public or private road or waterway is not unduly impeded, interrupted nor endangered by the performance or existence of the Work, Material or Plant;
  - (c) fire hazards in or about the site of the Work are eliminated and any fire is promptly extinguished;
  - (d) the health and safety of all persons employed in the performance of the Work is not endangered by the methods nor means of their performance;
  - (e) adequate medical services are available to all persons employed on the Work or its site at all times during the performance of the Work;
  - (f) adequate sanitation measures are taken in respect of the Work and its site; and
  - (g) all stakes, buoys and marks placed on the Work or its site by Canada are protected and are not removed, defaced, altered nor destroyed.
- 2) Canada may direct the Contractor to do such things and to perform such work as Canada considers reasonable and necessary to ensure compliance with or to remedy a breach of paragraph 1) of GC4.2, and the Contractor shall comply with the direction of Canada.

**GC4.3 MATERIAL, PLANT AND REAL PROPERTY SUPPLIED BY CANADA**

- 1) Subject to paragraph 2) of GC4.3, the Contractor is liable to Canada for any loss of or damage to Material, Plant or real property that is supplied or placed in the care, custody and control of the Contractor by Canada for use in connection with the Contract, whether or not that loss or damage is attributable to causes beyond the Contractor's control.
- 2) The Contractor is not liable to Canada for any loss or damage to Material, Plant or real property referred to in paragraph 1) of GC4.3 if that loss or damage results from and is directly attributable to reasonable wear and tear.
- 3) The Contractor shall not use any Material, Plant or real property supplied by Canada except for the purpose of performing the Contract.
- 4) When the Contractor fails to make good any loss or damage for which the Contractor is liable under paragraph 1) within a reasonable time, Canada may cause the loss or damage to be made good at the Contractor's expense, and the Contractor shall thereupon be liable to Canada for the cost thereof and shall, on demand, pay to Canada an amount equal to that cost.
- 5) The Contractor shall keep records of all Material, Plant and real property supplied by Canada as Canada requires and shall satisfy Canada, when requested, that such Material, Plant and real property are at the place and in the condition in which they ought to be.

**GC4.4 CONTAMINATED SITE CONDITIONS**

- 1) For the purposes of GC4.4, a contaminated site condition exists when a solid, liquid, gaseous, thermal or radioactive irritant or contaminant, or other hazardous or toxic substance or material, including moulds and other forms of fungi, is present at the site of the Work to an extent that constitutes a hazard, or potential hazard, to the environment, property, or the health or safety of any person.
- 2) If the Contractor encounters a contaminated site condition of which the Contractor is not aware or about which the Contractor has not been advised, or if the Contractor has reasonable grounds to believe that such a site condition exists at the site of the Work, the Contractor shall
  - (a) take all reasonable steps, including stopping the Work, to ensure that no person suffers injury, sickness or death, and that neither property nor the environment is injured or destroyed as a result of the contaminated site condition;
  - (b) immediately notify Canada of the circumstances in writing; and
  - (c) take all reasonable steps to minimize additional costs that may accrue as a result of any work stoppage.
- 3) Upon receipt of a notification from the Contractor, Canada shall promptly determine whether a contaminated site condition exists, and shall notify the Contractor in writing of any action to be taken, or work to be performed, by the Contractor as a result of Canada's determination.
- 4) If the Contractor's services are required by Canada, the Contractor shall follow the direction of Canada with regard to any excavation, treatment, removal and disposal of any polluting substance or material.

- 5) Canada, at Canada's sole discretion, may enlist the services of experts and specialty contractors to assist in determining the existence of, and the extent and treatment of contaminated site conditions, and the Contractor shall allow them access and co-operate with them in the carrying out of their duties and obligations.
- 6) Except as may be otherwise provided for in the Contract, the provisions of GC6.4 DETERMINATION OF PRICE shall apply to any additional work made necessary because of a contaminated site condition.



**GC5 TERMS OF PAYMENT**

- GC5.1 INTERPRETATION
- GC5.2 AMOUNT PAYABLE
- GC5.3 INCREASED OR DECREASED COSTS
- GC5.4 PROGRESS PAYMENT
- GC5.5 SUBSTANTIAL PERFORMANCE OF THE WORK
- GC5.6 FINAL COMPLETION
- GC5.7 PAYMENT NOT BINDING ON CANADA
- GC5.8 CLAIMS AND OBLIGATIONS
- GC5.9 RIGHT OF SETOFF
- GC5.10 ASSESSMENTS AND DAMAGES FOR LATE COMPLETION
- GC5.11 DELAY IN MAKING PAYMENT
- GC5.12 INTEREST ON SETTLED CLAIMS
- GC5.13 RETURN OF SECURITY DEPOSIT

**GC5.1 INTERPRETATION**

In these Terms of Payment

- 1) The "payment period" means a period of 30 consecutive days or such other longer period as may be agreed between the Contractor and Canada.
- 2) An amount is "due and payable" when it is due and payable by Canada to the Contractor according to GC5.4 PROGRESS PAYMENT, GC5.5 SUBSTANTIAL PERFORMANCE OF THE WORK or GC5.6 FINAL COMPLETION.
- 3) An amount is "overdue" when it remains unpaid on the first day following the day upon which it is due and payable.
- 4) The "date of payment" means the date of the negotiable instrument of an amount due and payable by the Receiver General for Canada.
- 5) The "Bank Rate" means the rate of interest established by the Bank of Canada as the minimum rate at which it makes short term advances to members of the Canadian Payments Association.
- 6) The "Average Bank Rate" means the simple arithmetic mean of the Bank Rate in effect at 4:00 p.m. Eastern Time each day during the calendar month which immediately precedes the calendar month in which payment is made.

**GC5.2 AMOUNT PAYABLE**

- 1) Subject to any other provisions of the Contract, Canada shall pay the Contractor, at the times and in the manner hereinafter set out, the amount by which the amounts payable by Canada to the Contractor in accordance with the Contract exceed the amounts payable by the Contractor to Canada, and the Contractor shall accept that amount as payment in full satisfaction for everything furnished and done by the Contractor in respect of the Work to which the payment relates.
- 2) When making any payment to the Contractor, the failure of Canada to deduct an amount payable to Canada by the Contractor shall not constitute a waiver of the right to do so, or an admission of lack of entitlement to do so in any subsequent payment to the Contractor.

- 3) Should any payment be made by Canada in excess of what is owed to the Contractor for the actual work performed, the Contractor will reimburse Canada the excess immediately, with or without demand, and any amounts outstanding shall bear simple interest at the Average Bank rate plus 3 percent per annum from the date of overpayment until the day prior to the date of repayment by the Contractor.
- 4) No payment other than a payment that is expressly stipulated in the Contract shall be made by Canada to the Contractor for any extra expense or any loss or damage incurred or sustained by the Contractor.

### **GC5.3 (2016-05-01) INCREASED OR DECREASED COSTS**

1. The Contract Amount shall not be increased nor decreased by reason of any increase or decrease in the cost of the Work that is brought about by an increase or decrease in the cost of labour, Plant, Material or any wage adjustment.
2. Notwithstanding paragraph 1) of GC5.3, if any change, including a new imposition or repeal, of any tax, customs or other duty, charge, or any similar imposition that is imposed under sales, customs or excise tax legislation of the Government of Canada or any Provincial or Territorial legislation, affects the cost of the Work to the Contractor, and occurs
  - a) after the date of submission by the Contractor of its bid; or
  - b) after the date of submission of the last revision, if the Contractor's bid was revised;
  - c) the Contract Amount shall be adjusted in the manner provided in paragraph 3) of GC5.3.
3. If a change referred to in paragraph 2) of GC5.3 occurs, the Contract Amount shall be increased or decreased by an amount established by an examination by Canada of the relevant records of the Contractor referred to in GC2.8, "Accounts and Audits", to be the increase or decrease in the cost incurred by the Contractor that is directly attributable to that change.
4. For the purpose of paragraph 2) of GC5.3, if a tax is changed after the tender closing, but public notice of the change has been given by the Minister of Finance or the corresponding Provincial or Territorial authority before that closing, the change shall be deemed to have occurred before the solicitation closing.
5. Notwithstanding paragraphs 2) to 4) of GC5.3, no adjustment to the Contract Amount in respect of the Work or a part thereof shall be made for a change in any imposition referred to in this section that occurs after the date required by the Contract for completion of the Work or that part of the Work.

### **GC5.4 (2016-05-01) PROGRESS PAYMENT**

- 1) On the expiration of a payment period, the Contractor shall deliver to Canada
  - a) a written progress claim in a form acceptable to Canada that fully describes any part of the Work that has been completed, and any Material that was delivered to the Work site but not incorporated into the Work, during that payment period, and

- b) a completed and signed statutory declaration containing a declaration that, up to the date of the progress claim, the Contractor has complied with all lawful obligations and that, in respect of the Work, all lawful obligations of the Contractor to its Subcontractors and Suppliers, referred to collectively in the declaration as "subcontractors and suppliers", have been fully discharged.
- 2) Within 10 days of receipt of a progress claim and statutory declaration from the Contractor, Canada shall inspect, or cause to have inspected, the part of the Work and the Material described in the progress claim, and shall issue a progress report to the Contractor, that indicates the value of the part of the Work and the Material described in the progress claim that, in the opinion of Canada
    - a) is in accordance with the Contract; and
    - b) was not included in any other progress report relating to the Contract.
  - 3) Subject to GC5.2, "Amount Payable", and paragraph 5) of GC5.4, Canada shall pay the Contractor an amount that is equal to
    - a) 95 percent of the value that is indicated in Canada's progress report if a labour and material payment bond has been furnished by the Contractor; or
    - b) 90 percent of the value that is indicated in Canada's progress report if a labour and material payment bond has not been furnished by the Contractor.
  - 4) Canada shall pay the amount referred to in paragraph 3) of GC5.4 not later than
    - a) 30 days after receipt by Canada of both a progress claim and a statutory declaration referred to in paragraph 1) of GC5.4; or
    - b) 15 days after receipt by Canada of the Contractor's progress schedule or updated progress schedule, in accordance with GC3.1, "Progress Schedule",whichever is later.
  - 5) In the case of the Contractor's first progress claim, it is a condition precedent to Canada's obligation under paragraph 3) of GC5.4 that the Contractor has provided all necessary documentation required by the Contract for the first progress claim.

#### **GC5.5 (2016-05-01) SUBSTANTIAL PERFORMANCE OF THE WORK**

1. If, at any time before the issuance of a Certificate of Completion, Canada determines that the Work has reached Substantial Performance as described in subparagraph 1) (b) of GC1.1.4, "Substantial Performance", Canada shall issue a Certificate of Substantial Performance to the Contractor. The Certificate of Substantial Performance shall state or describe
  - a) the date of Substantial Performance;
  - b) the parts of the Work not completed to the satisfaction of Canada; and
  - c) all things that must be done by the Contractor before a Certificate of Completion is issued and before the 12-month warranty period referred to in GC3.13, "Warranty and Rectification of Defects in Work", commences for the said parts and all the said things.

2. The issuance of a Certificate of Substantial Performance does not relieve the Contractor from the Contractor's obligations under GC3.11, "Defective Work".
3. Subject to GC5.2, "Amount Payable", and paragraph 4) of GC5.5, Canada shall pay the Contractor the amount referred to in paragraph 1) of GC5.2, "Amount Payable", less the aggregate of
  - a) the sum of all payments that were made pursuant to GC5.4, "Progress Payment";
  - b) an amount that is equal to Canada's estimate of the cost to Canada of rectifying defects described in the Certificate of Substantial Performance; and
  - c) an amount that is equal to Canada's estimate of the cost to Canada of completing the parts of the Work described in the Certificate of Substantial Performance other than defects listed therein.
4. Canada shall pay the amount referred to in paragraph 3) of GC5.5 not later than
  - a) 30 days after the date of issue of a Certificate of Substantial Performance, or
  - b) 15 days after the Contractor has delivered to Canada
    - I. a statutory declaration containing a declaration by the Contractor that up to the date of the Certificate of Substantial Performance, the Contractor has complied with all lawful obligations, discharged all its lawful obligations to its Subcontractors and Suppliers in respect of the work under the Contract, and discharged its lawful obligations referred to in GC1.8, "Laws, Permits and Taxes";
    - II. evidence of compliance with workers' compensation legislation in accordance with GC1.9, "Workers' Compensation"; and
    - III. an update of the progress schedule in accordance with the requirements of GC3.1, "Progress Schedule"; whichever is later.

#### **GC5.6 FINAL COMPLETION**

- 1) When Canada is of the opinion that the Contractor has complied with the Contract and all orders and directions made pursuant thereto, and that the Work has been completed as described in GC1.1.5 COMPLETION, Canada shall issue a Certificate of Completion to the Contractor and, if the Work or a portion of the Work is subject to a Unit Price Arrangement, Canada shall issue a Certificate of Measurement that shall, subject to GC8, be binding upon and conclusive between Canada and the Contractor as to the quantities referred to therein.
- 2) Subject to GC5.2 AMOUNT PAYABLE and paragraph 3) of GC5.6, Canada shall pay the Contractor the amount referred to in GC5.2 AMOUNT PAYABLE, less the aggregate of the sum of all payments that were made pursuant to GC5.4 PROGRESS PAYMENT and GC5.5 SUBSTANTIAL PERFORMANCE OF WORK.
- 3) Canada shall pay the amount referred to in paragraph 2) of GC5.6 not later than
  - a) 60 days after the date of issue of a Certificate of Completion; or
  - b) 15 days after the Contractor has delivered to Canada

- (i) a statutory declaration which contains a declaration by the Contractor that all of the Contractor's lawful obligations and any lawful claims against the Contractor that arose out of the performance of the Contract have been discharged and satisfied; and
- (ii) evidence of compliance with workers' compensation legislation in accordance with GC1.9 WORKERS' COMPENSATION;

whichever is later.

#### **GC5.7 (2016-05-01) PAYMENT NOT BINDING ON CANADA**

- 1) Neither acceptance of a progress claim or progress report, nor any payment made by Canada under the Contract, nor partial or entire use or occupancy of the Work by Canada shall constitute an acceptance by Canada of any portion of the Work or Material that is not in accordance with the requirements of the Contract.

#### **GC5.8 CLAIMS AND OBLIGATIONS**

- 1) The Contractor shall discharge all the Contractor's lawful obligations and shall satisfy all lawful claims against the Contractor arising out of the performance of the Work at least as often as the Contract requires Canada to pay the Contractor.
- 2) Whenever requested to do so by Canada, the Contractor shall make a statutory declaration declaring to the existence and condition of any obligations and claims against the Contractor arising out of the performance of the Work.
- 3) In order to discharge lawful obligations of and satisfy lawful claims against the Contractor or its Subcontractors arising out of the performance of the Contract, Canada may pay an amount that is due and payable to the Contractor directly to the claimant. Such payment is, to the extent of the payment, a discharge of Canada's liability to the Contractor under the Contract and may be deducted from any amount payable to the Contractor under the Contract.
- 4) For the purposes of paragraph 3) of GC5.8, and subject to paragraph 6) of GC5.8, a claim or obligation shall be considered lawful when it is so determined by
  - (a) a court of legal jurisdiction;
  - (b) an arbitrator duly appointed to arbitrate the claim; or
  - (c) the written consent of the Contractor authorizing payment of the claim or obligation.
- 5) If a claim or obligation would have been subject to the provisions of Provincial or Territorial lien legislation or, in the Province of Quebec, the law relating to legal hypothecs had the Contractor been performing the Work for an entity other than Canada
  - (a) such amount as may be paid by Canada pursuant to paragraphs 3) and 4) of GC5.8 shall not exceed the amount that the Contractor would have been obliged to pay had the provisions of such legislation or law been applicable to the Work;
  - (b) a claimant need not comply with the provisions of such legislation, setting out the steps by way of notice, registration or otherwise as might have been necessary to preserve or perfect any claim for lien or privilege which the claimant might have had; and

- (c) for the purposes of determining the entitlement of a claimant, the notice required by paragraph 8) of GC5.8 shall be deemed to replace the registration or provision of notice after the performance of work as required by any applicable legislation and no claim shall be deemed to have expired, become void or unenforceable by reason of the claimant not commencing any action within the time prescribed by such legislation.
- 6) The Contractor shall, at the request of any claimant, submit to binding arbitration those questions that need to be answered to establish the entitlement of the claimant to payment. The arbitration shall have as parties to it any Subcontractor or Supplier to whom the claimant supplied Material, performed work or rented equipment should such Subcontractor or Supplier wish to be adjoined, and Canada shall not be a party to such arbitration. Subject to any agreement between the Contractor and the claimant, the arbitration shall be conducted in accordance with the governing Provincial or Territorial legislation applicable to the site of the Work.
- 7) Paragraph 3) of GC5.8 shall apply only to claims and obligations
  - (a) the notification of which has set forth the amount claimed to be owing and the person who by contract is primarily liable and has been received by Canada in writing before final payment is made to the Contractor pursuant to GC5.6 FINAL COMPLETION, and within 120 days of the date on which the claimant
    - (i) should have been paid in full under the claimant's contract with the Contractor, its Subcontractor or Supplier if the claim is for money that was lawfully required to be held back from the claimant; or
    - (ii) performed the last of the services, work or labour, or furnished the last of the Material pursuant to the claimant's contract with the Contractor or its Subcontractor or Supplier where the claim is for money not lawfully required to be held back from the claimant; and
  - (b) the proceedings to determine the right to payment of which, pursuant to paragraph 5) of GC5.8, shall have commenced within one year from the date that the notification required by subparagraph 7)(a) of GC5.8 was received by Canada.
- 8) Upon receipt of a notice of claim, Canada may withhold, from any amount that is due and payable to the Contractor pursuant to the Contract, the full amount of the claim or any portion thereof.
- 9) Canada shall notify the Contractor in writing in a timely manner of receipt of any claim and of the intention of Canada to withhold funds. At any time thereafter and until payment is made to the claimant, the Contractor may be entitled to post, with Canada, security in a form acceptable to Canada in an amount equal to the value of the claim, and upon receipt of such security Canada shall release to the Contractor any funds that would be otherwise payable to the Contractor, that were withheld pursuant to the provisions of this clause in respect of the claim of any claimant for whom the security stands.

#### **GC5.9 RIGHT OF SETOFF**

- 1) Without limiting any right of setoff or deduction given or implied by law or elsewhere in the Contract, Canada may set off any amount payable to Canada by the Contractor under the Contract, or under any current contract, against any amount payable to the Contractor under the Contract.

- 2) For the purposes of paragraph 1) of GC5.9, "current contract" means a contract between Canada and the Contractor
  - (a) under which the Contractor has an undischarged obligation to perform or supply work, labour or material; or
  - (b) in respect of which Canada has, since the date of the Contract, exercised any right to take the work that is the subject of that contract out of the Contractor's hands.

#### **GC5.10 ASSESSMENTS AND DAMAGES FOR LATE COMPLETION**

- 1) For the purposes of this clause
  - (a) the Work shall be deemed to be completed on the date of the Certificate of Completion; and
  - (b) the "period of delay" means the number of days commencing on the day fixed for completion of the Work and ending on the day immediately preceding the day on which the Work is completed but does not include any day within a period of extension granted pursuant to GC6.5 DELAYS AND EXTENSION OF TIME and any other day on which, in the opinion of Canada, completion of the Work was delayed for reasons beyond the control of the Contractor.
- 2) If the Contractor does not complete the Work by the day fixed for its completion but completes it thereafter, the Contractor shall pay Canada an amount equal to the aggregate of
  - (a) all salaries, wages and travelling expenses incurred by Canada in respect of persons overseeing the performance of the Work during the period of delay;
  - (b) the cost incurred by Canada as a result of the inability to use the completed Work for the period of delay; and
  - (c) all other expenses and damages incurred or sustained by Canada during the period of delay as a result of the Work not being completed by the day fixed for its completion.
- 3) Canada may waive the right of Canada to the whole or any part of the amount payable by the Contractor pursuant to paragraph 2) of GC5.10 if, in the opinion of Canada, it is in the public interest to do so.

#### **GC5.11 DELAY IN MAKING PAYMENT**

- 1) Notwithstanding GC1.5 TIME OF THE ESSENCE, any delay by Canada in making any payment when it is due pursuant to GC5 TERMS OF PAYMENT, shall not be a breach of the Contract by Canada.
- 2) Subject to paragraph 3) of GC5.11, Canada shall pay to the Contractor simple interest at the Average Bank Rate plus 3 percent per annum on any amount that is overdue pursuant to paragraph 3) of GC5.1 INTERPRETATION, and the interest shall apply from and include the day such amount became overdue until the day prior to the date of payment.
- 3) Interest shall be paid without demand by the Contractor except that

- (a) in respect of amounts that are less than 15 days overdue, no interest shall be paid in respect of payment made within such 15 days unless the Contractor so demands after such amounts have become due and payable; and
- (b) interest shall not be payable or paid on overdue advance payments, if any.

**GC5.12 INTEREST ON SETTLED CLAIMS**

- 1) For the purposes of this clause, a claim means a disputed amount subject to negotiation between Canada and the Contractor under the Contract.
- 2) A claim is deemed to have been settled when an agreement in writing is signed by Canada and the Contractor setting out the amount of the claim to be paid by Canada and the items of work for which the said amount is to be paid.
- 3) A settled claim is deemed to be outstanding from the day immediately following the date the said claim would have been due and payable under the Contract had it not been disputed.
- 4) Canada shall pay to the Contractor simple interest on the amount of a settled claim at the Average Bank Rate plus 3 percent per annum from the date the settled claim was deemed to be outstanding until the day prior to the date of payment.

**GC5.13 RETURN OF SECURITY DEPOSIT**

- 1) After a Certificate of Substantial Performance has been issued, and if the Contractor is not in breach of nor in default under the Contract, Canada shall return to the Contractor all or any part of a Security Deposit that, in the opinion of Canada, is not required for the purposes of the Contract.
- 2) After a Certificate of Completion has been issued, Canada shall return to the Contractor the remainder of any security deposit unless the Contract stipulates otherwise.
- 3) If the security deposit was paid into the Consolidated Revenue Fund of Canada, Canada shall pay interest thereon to the Contractor at a rate established pursuant to section 21(2) of the [Financial Administration Act \(FAA\)](#).



**GC6 DELAYS AND CHANGES IN THE WORK**

- GC6.1 CHANGES IN THE WORK
- GC6.2 CHANGES IN SUBSURFACE CONDITIONS
- GC6.3 HUMAN REMAINS, ARCHAEOLOGICAL REMAINS AND ITEMS OF HISTORICAL OR SCIENTIFIC INTEREST
- GC6.4 DETERMINATION OF PRICE
  - GC6.4.1 Price Determination Prior to Undertaking Changes
  - GC6.4.2 Price Determination Following Completion of Changes
  - GC6.4.3 Price Determination - Variations in Tendered Quantities
- GC6.5 DELAYS AND EXTENSION OF TIME

**GC6.1 CHANGES IN THE WORK**

- 1) At any time before issuance of a Certificate of Completion, Canada may issue orders for additions, deletions or other changes to the Work, or changes in the location or position of the whole or any part of the Work, if the addition, deletion, change or other revision is deemed by Canada to be consistent with the general intent of the Contract.
- 2) An order referred to in paragraph 1) of GC6.1 shall be in writing and given to the Contractor in accordance with GC2.3 NOTICES.
- 3) Upon receipt of an order, the Contractor shall promptly perform the work in accordance with the order as if the order had appeared in and been part of the original Contract.
- 4) If anything done or omitted by the Contractor pursuant to an order increases or decreases the cost of the Work to the Contractor, payment for the work shall be made in accordance with GC6.4 DETERMINATION OF PRICE.

**GC6.2 CHANGES IN SUBSURFACE CONDITIONS**

- 1) If, during the performance of the Work, the Contractor encounters subsurface conditions that are substantially different from the subsurface conditions described in the tender documents supplied to the Contractor, or a reasonable assumption of fact based thereon, the Contractor shall give notice to Canada immediately upon becoming aware of the situation.
- 2) If the Contractor is of the opinion that the Contractor may incur or sustain any extra expense or any loss or damage that is directly attributable to the changed subsurface conditions, the Contractor shall within 10 days of the date the changed subsurface conditions were encountered, give Canada written notice of intention to claim for that extra expense, loss or damage.
- 3) If the Contractor has given a notice referred to in paragraph 2) of GC6.2, the Contractor shall give Canada a written claim for extra expense, loss or damage no later than 30 days after the date that a Certificate of Substantial Performance is issued.
- 4) A written claim referred to in paragraph 3) of GC6.2 shall contain a sufficient description of the facts and circumstances of the occurrence that is the subject of the claim to enable Canada to determine whether or not the claim is justified, and the Contractor shall supply such further and other information for that purpose as Canada requires.
- 5) If Canada determines that a claim referred to in paragraph 3) of GC6.2 is justified, Canada shall make an extra payment to the Contractor in an amount that is calculated in accordance with GC6.4 DETERMINATION OF PRICE.

- 6) If, in the opinion of Canada, the Contractor effects a saving of expenditure that is directly attributable to a substantial difference between the information relating to subsurface conditions at the site of the Work that is contained in the tender documents, or a reasonable assumption of fact based thereon, and the actual subsurface conditions encountered by the Contractor, the Contract Amount shall be reduced by the amount of the saving of expenditure determined in accordance with GC6.4 DETERMINATION OF PRICE.
- 7) If the Contractor fails to give a notice referred to in paragraph 2) of GC6.2 and a claim referred to in paragraph 3) of GC6.2 within the times stipulated, an extra payment shall not be made to the Contractor in respect of the occurrence.
- 8) Canada does not warrant the content expressed in any subsurface report available for the perusal of the Contractor that does not form part of the tender and contract documents.

### **GC6.3 HUMAN REMAINS, ARCHAEOLOGICAL REMAINS AND ITEMS OF HISTORICAL OR SCIENTIFIC INTEREST**

- 1) For the purposes of this clause
  - (a) "human remains" means the whole or any part of a deceased human being, irrespective of the time of death;
  - (b) "archaeological remains" are items, artefacts or things made, modified or used by human beings in antiquity and may include, but not be limited to, stone, wood or iron structures or monuments, dump deposits, bone artefacts, weapons, tools, coins, and pottery; and
  - (c) "items of historical or scientific interest" are naturally occurring or manufactured objects or things of any age that are not archaeological remains but may be of interest to society because of their historical or scientific significance, value, rarity, natural beauty, or other quality.
- 2) If, during the course of the Work, the Contractor encounters any object, item or thing which is described in paragraph 1) of GC6.3 or which resembles any object, item or thing described in paragraph 1) of GC6.3, the Contractor shall
  - (a) take all reasonable steps, including stopping work in the affected area, to protect and preserve the object, item or thing;
  - (b) immediately notify Canada of the circumstances in writing; and
  - (c) take all reasonable steps to minimize additional costs that may accrue as a result of any work stoppage.
- 3) Upon receipt of a notification in accordance with subparagraph 2)(b) of GC6.3, Canada shall promptly determine whether the object, item or thing is one described in, or contemplated by paragraph 1) of GC6.3, and shall notify the Contractor in writing of any action to be performed, or work to be carried out, by the Contractor as a result of Canada's determination.
- 4) Canada may, at any time, enlist the services of experts to assist in the investigation, examination, taking of measurements or other such recordings, placing of permanent protection around or removing of the object, item or thing encountered by the Contractor, and the Contractor shall, to the satisfaction of Canada, allow them access and co-operate with them in the carrying out of their duties and obligations.

- 5) Human remains, archaeological remains and items of historical or scientific interest encountered at the site of the Work shall be deemed to be the property of Canada.
- 6) Except as may be otherwise provided for in the Contract, the provisions of GC6.4 DETERMINATION OF PRICE and GC6.5 DELAYS AND EXTENSION OF TIME shall apply.

## **GC6.4 DETERMINATION OF PRICE**

### **GC6.4.1 Price Determination Prior to Undertaking Changes**

- 1) If a Lump Sum Arrangement applies to the Contract or a part thereof, the price of any change shall be the aggregate estimated cost of labour, Plant and Material that is required for the change as agreed upon in writing by the Contractor and Canada plus a negotiated allowance for supervision, co-ordination, administration, overhead, margin and the risk of undertaking the work within the stipulated amount.
- 2) If a Unit Price Arrangement applies to the Contract or a part thereof, the Contractor and Canada may, by agreement in writing, add items, units of measurement, estimated quantities and prices per unit to the Unit Price Table.
- 3) A price per unit referred to in paragraph 2) of GC6.4.1 shall be determined on the basis of the aggregate estimated cost of labour, Plant and Material that is required for the additional item as agreed upon by the Contractor and Canada, plus a negotiated allowance.
- 4) To facilitate approval of the price of the change or the additional price per unit as applicable, the Contractor shall submit a cost estimate breakdown identifying, as a minimum, the estimated cost of labour, Plant, Material, each subcontract amount, and the amount of the negotiated allowance.
- 5) If no agreement is reached as contemplated in paragraph 1) of GC6.4.1, the price shall be determined in accordance with GC6.4.2.
- 6) If no agreement is reached, as contemplated in paragraphs 2) and 3) of GC6.4.1, Canada shall determine the class and the unit of measurement of the item of labour, Plant or Material and the price per unit shall be determined in accordance with GC6.4.2.

### **GC6.4.2 Price Determination Following Completion of Changes**

- 1) If it is not possible to predetermine, or if there is failure to agree upon the price of a change in the Work, the price of the change shall be equal to the aggregate of
  - (a) all reasonable and proper amounts actually expended or legally payable by the Contractor in respect of the labour, Plant and Material that fall within one of the classes of expenditure described in paragraph 2) of GC6.4.2, that are directly attributable to the performance of the Contract;
  - (b) an allowance for profit and all other expenditures or costs, including overhead, general administration costs, financing and interest charges, in an amount that is equal to 10 percent of the sum of the expenses referred to in subparagraph 1)(a) of GC6.4.2; and
  - (c) interest on the amounts determined under subparagraphs 1)(a) and 1)(b) of GC6.4.2 calculated in accordance with GC5.12 INTEREST ON SETTLED CLAIMS;

- 2) The cost of labour, Plant and Material referred to in subparagraph 1)(a) of GC6.4.2 shall be limited to the following categories of expenditure:
- (a) payments to Subcontractors and Suppliers;
  - (b) wages, salaries, bonuses and, if applicable, travel and lodging expenses of employees of the Contractor located at the site of the Work and that portion of wages, salaries, bonuses and, if applicable, travel and lodging expenses of personnel of the Contractor generally employed at the head office or at a general office of the Contractor provided they are actually and properly engaged on the Work under the Contract;
  - (c) assessments payable under any statutory authority relating to workers' compensation, employment insurance, pension plan or holidays with pay, provincial health or insurance plans, environmental reviews, and Applicable Taxes collection costs;
  - (d) rent that is paid for Plant, or an amount equivalent to the said rent if the Plant is owned by the Contractor, that is necessary for and used in the performance of the Work, if the rent or the equivalent amount is reasonable and use of that Plant has been approved by Canada;
  - (e) payments for maintaining and operating Plant necessary for and used in the performance of the Work, and payments for effecting repairs thereto that, in the opinion of Canada, are necessary for the proper performance of the Contract, other than payments for any repairs to the Plant arising out of defects existing before its allocation to the Work;
  - (f) payments for Material that is necessary for and incorporated in the Work, or that is necessary for and consumed in the performance of the Contract;
  - (g) payments for preparation, delivery, handling, erection, installation, inspection, protection and removal of the Plant and Material necessary for and used in the performance of the Contract; and
  - (h) any other payments made by the Contractor with the approval Canada that are necessary for the performance of the Contract in accordance with the Contract Documents.

#### **GC6.4.3 Price Determination - Variations in Tendered Quantities**

- 1) Except as provided in paragraphs 2), 3), 4) and 5) of GC6.4.3, if it appears that the final quantity of labour, Plant and Material under a price per unit item shall exceed or be less than the estimated tendered quantity, the Contractor shall perform the Work or supply the Plant and Material required to complete the item and payment shall be made for the actual Work performed or Plant and Material supplied at the price per unit set out in the Contract.
- 2) If the final quantity of the price per unit item exceeds the estimated tendered quantity by more than 15 percent, either party to the Contract may make a written request to the other party to negotiate an amended price per unit for that portion of the item which exceeds 115 percent of the estimated tendered quantity, and to facilitate approval of any amended price per unit, the Contractor shall, on request, provide Canada with
- (a) detailed records of the actual cost to the Contractor of performing or supplying the tendered quantity for the price per unit item up to the time the negotiation was requested; and

- (b) the estimated unit cost of labour, Plant and Material required for the portion of the item that is in excess of 115 percent of the tendered quantity.
- 3) If agreement is not reached as contemplated in paragraph 2) of GC6.4.3, the price per unit shall be determined in accordance with GC6.4.2.
  - 4) If it appears that the final quantity of labour, Plant and Material under a price per unit item shall be less than 85 percent of the estimated tendered quantity, either party to the Contract may make a written request to the other party to negotiate a change to the price per unit for the item if
    - (a) there is a demonstrable difference between the unit cost to the Contractor of performing or supplying the estimated tendered quantity and the unit cost to the Contractor for performing or supplying the final quantity; and
    - (b) the difference in unit cost is due solely to the decrease in quantity and not to any other cause.
  - 5) For the purposes of the negotiation referred to in paragraph 4) of GC6.4.3
    - (a) the onus of establishing, justifying and quantifying a proposed change lies with the party making the request for negotiation; and
    - (b) in no event shall the total price for an item that has been amended as a result of a reduction in quantity pursuant to paragraph 4) of GC6.4.3 exceed the amount that would have been payable to the Contractor had 85 percent of the tendered quantity actually been performed or supplied.

**GC6.5 DELAYS AND EXTENSION OF TIME**

- 1) Upon application of the Contractor made before the date first fixed for completion of the Work or before any other date previously fixed under this clause, Canada may extend the time for completion of the Work by fixing a new date if Canada determines that causes beyond the control of the Contractor have delayed its completion.
- 2) The Contractor's application shall be accompanied by the written consent of the bonding company whose bond forms part of the Contract Security.
- 3) Subject to paragraph 4) of GC6.5, no payment, other than a payment that is expressly stipulated in the Contract, shall be made by Canada to the Contractor for any extra expense, loss or damage incurred or sustained by the Contractor due to delay, whether or not the delay is caused by circumstances beyond the control of the Contractor.
- 4) If the Contractor incurs or sustains any extra expense or any loss or damage that is directly attributable to any neglect or delay that occurs after the date of the Contract on the part of Canada in providing any information or in doing any act that the Contract either expressly requires Canada to do or that would ordinarily be done by an owner in accordance with the practice of the trade, the Contractor shall give Canada written notice of intention to claim for that extra expense or loss or damage within ten working days of the date the neglect or delay first occurred.
- 5) When the Contractor has given a notice referred to in paragraph 4) of GC6.5, the Contractor shall give Canada a written claim for the extra expense, loss or damage no later than 30 days after the date that a Certificate of Completion is issued and not afterwards.

- 6) A written claim referred to in paragraph 5) of GC6.5 shall contain a sufficient description of the facts and circumstances of the occurrence that is the subject of the claim to enable Canada to determine whether or not the claim is justified and the Contractor shall supply such further and other information for that purpose as Canada may require.
- 7) If Canada determines that a claim referred to in paragraph 5) of GC6.5 is justified, Canada shall make an extra payment to the Contractor in an amount that is calculated in accordance with GC6.4 DETERMINATION OF PRICE.
- 8) If the Contractor fails to give a notice referred to in paragraph 4) and a claim referred to in paragraph 5) of GC6.5 within the times stipulated, an extra payment shall not be made to the Contractor in respect of the occurrence.

**GC7 DEFAULT, SUSPENSION OR TERMINATION OF CONTRACT**

GC7.1 TAKING THE WORK OUT OF THE CONTRACTOR'S HANDS

GC7.2 SUSPENSION OF WORK

GC7.3 TERMINATION OF CONTRACT

GC7.4 SECURITY DEPOSIT - FORFEITURE OR RETURN

**GC7.1 TAKING THE WORK OUT OF THE CONTRACTOR'S HANDS**

- 1) By giving notice in writing to the Contractor in accordance with GC2.3 NOTICES, Canada, without any other authorization, may take all or any part of the Work out of the Contractor's hands, and may employ such means as Canada sees fit to have the Work completed if the Contractor:
  - (a) fails to remedy any delay in the commencement or default in the diligent performance of the Work to the satisfaction of Canada within six days of Canada giving notice to the Contractor in writing in accordance with GC2.3 NOTICES;
  - (b) defaults in the completion of any part of the Work within the time fixed for its completion by the Contract;
  - (c) becomes insolvent, or has committed an act of bankruptcy, and has neither made a proposal to its creditors nor filed a notice of intention to make such a proposal, pursuant to the [\*Bankruptcy and Insolvency Act\*](#);
  - (d) abandons the work;
  - (e) makes an assignment of the Contract without the consent required by GC1.16 ASSIGNMENT; or
  - (f) otherwise fails to observe or perform any of the provisions of the Contract.
- 2) If the whole or any part of the Work is taken out of the Contractor's hands, the Contractor's right to any further payment that is due or accruing due under the Contract is, subject only to paragraph 3) of GC7.1, extinguished, and the Contractor is liable to pay Canada, upon demand, an amount that is equal to the amount of all loss and damage incurred or sustained by Canada in respect of the Contractor's failure to complete the Work.
- 3) If the whole or any part of the Work that is taken out of the Contractor's hands is completed by Canada, Canada may pay the Contractor the amount, if any, of the holdback or a progress claim as determined by Canada that had accrued and was due prior to the date on which the Work was taken out of the Contractor's hands and that is not required for the purposes of having the Work performed or of compensating Canada for any other loss or damage incurred or sustained by reason of the Contractor's default.
- 4) The taking of the Work or any part thereof out of the Contractor's hands does not relieve the Contractor from any obligation under the Contract or imposed by law except the obligation to complete the performance of that part of the Work that was taken out of the Contractor's hands.
- 5) If the Work or any part thereof is taken out of the Contractor's hands, all Plant and Material and the interest of the Contractor, or its suppliers or subcontractors at any tier, in all real property, licences, powers and privileges acquired, used or provided by the Contractor, or its suppliers or subcontractors at any tier, under the Contract shall continue to be the property of Canada without compensation.

- 6) When Canada certifies that any Plant, Material, or any interest of the Contractor is no longer required for the purposes of the Work, or that it is not in the interests of Canada to retain that Plant, Material, or interest, it shall revert to the Contractor.
- 7) If the Contractor has become insolvent or has committed an act of bankruptcy, and has either made a proposal to its creditors or filed a notice of intention to make such a proposal, pursuant to the Bankruptcy and Insolvency Act, the Contractor shall immediately forward a copy of the proposal or the notice of intention to Canada.

#### **GC7.2 SUSPENSION OF WORK**

- 1) When, in Canada's opinion, it is in the public interest to do so, Canada may require the Contractor to suspend performance of the Work either for a specified or an unspecified period, by giving a notice of suspension in writing to the Contractor in accordance with GC2.3 NOTICES.
- 2) When a notice of suspension is received by the Contractor, the Contractor shall suspend all operations in respect of the Work except those that Canada determines are necessary for the care and preservation of the Work, Plant and Material.
- 3) During a period of suspension, the Contractor shall not remove any part of the Work, Plant or Material from its site without the consent of Canada.
- 4) If a period of suspension is 60 days or less, the Contractor shall resume the performance of the Work on the expiration of that period, and the Contractor is entitled to be paid the extra costs necessarily incurred by the Contractor as a result of the suspension, determined in accordance with GC6.4 DETERMINATION OF PRICE.
- 5) If a period of suspension is more than 60 days, Canada and the Contractor may agree that the performance of the Work shall be continued by the Contractor, and the Contractor shall resume performance of the Work subject to any terms and conditions agreed upon by Canada and the Contractor. If Canada and the Contractor do not agree that performance of the Work shall be continued by the Contractor, or upon the terms and conditions under which the Contractor shall continue the Work, the notice of suspension shall be deemed to be a notice of termination pursuant to GC7.3 TERMINATION OF CONTRACT.

#### **GC7.3 TERMINATION OF CONTRACT**

- 1) Canada may terminate the Contract at any time by giving a notice of termination in writing to the Contractor in accordance with GC2.3 NOTICES.
- 2) If the Contractor receives a notice of termination, the Contractor shall forthwith cease all operations in performance of the Contract, subject to any conditions stipulated in the notice.
- 3) Subject to paragraph 4) of GC7.3, if the Contract is terminated, Canada shall pay the Contractor an amount determined to be due to the Contractor pursuant to GC6.4 DETERMINATION OF PRICE less the aggregate of all amounts that were paid to the Contractor by Canada and all amounts that are due to Canada from the Contractor pursuant to the Contract.
- 4) In no event shall the total amount payable by Canada to the Contractor exceed the amount, calculated in accordance with GC5 TERMS OF PAYMENT, that would have been payable to the Contractor had the Contractor completed the Work.



- 5) Payment to the Contractor, if any, shall be made as soon as practicable under the circumstances.

**GC7.4 SECURITY DEPOSIT - FORFEITURE OR RETURN**

- 1) If the Work is taken out of the Contractor's hands, or the Contractor is in breach of, or in default under, the Contract, Canada may convert a security deposit to Canada's own use.
- 2) If Canada converts a security deposit, the amount realized shall be deemed to be an amount due from Canada to the Contractor under the Contract.
- 3) Any balance of the amount realized that remains after payment of all losses, damage and claims of Canada and others shall be paid by Canada to the Contractor if, in the opinion of Canada, it is not required for the purposes of the Contract.

**GC8 DISPUTE RESOLUTION**

- GC8.1 INTERPRETATION
- GC8.2 CONSULTATION AND CO-OPERATION
- GC8.3 NOTICE OF DISPUTE
- GC8.4 NEGOTIATION
- GC8.5 MEDIATION
- GC8.6 BINDING ARBITRATION
- GC8.7 DISPUTES NOT SUBJECT TO ARBITRATION
- GC8.8 CONFIDENTIALITY
- GC8.9 SETTLEMENT
- GC8.10 RULES FOR MEDIATION OF DISPUTES
  - GC8.10.1 Interpretation
  - GC8.10.2 Application
  - GC8.10.3 Communication
  - GC8.10.4 Appointment of Project Mediator
  - GC8.10.5 Confidentiality
  - GC8.10.6 Time and Place of Mediation
  - GC8.10.7 Representation
  - GC8.10.8 Procedure
  - GC8.10.9 Settlement Agreement
  - GC8.10.10 Termination of Mediation
  - GC8.10.11 Costs
  - GC8.10.12 Subsequent Proceedings

**GC8.1 INTERPRETATION**

- 1) "dispute" means any disagreement regarding any issue identified by the Contractor in the notice submitted to Canada in accordance with paragraph 2 of GC8.3 NOTICE OF DISPUTE, and includes any claim by the Contractor arising from such disagreement and any counterclaim by Canada, but does not include any claim by either party for punitive or exemplary damages, injury to persons, death, or any claim based on an allegation of libel or slander.
- 2) The alternative dispute resolution procedures set out in GC8, do not apply to any claim by Canada against the Contractor except any counterclaim in a dispute as defined in paragraph 1 of GC8.1, including, but not limited to, any claim of setoff regarding any amount due to Canada under GC5.10 ASSESSMENT AND DAMAGES FOR LATE COMPLETION.

**GC8.2 CONSULTATION AND CO-OPERATION**

- 1) The parties agree to maintain open and honest communication throughout the performance of the Contract.
- 2) The parties agree to consult and co-operate with each other in the furtherance of the Work and the resolution of problems or differences that may arise.

**GC8.3 NOTICE OF DISPUTE**

- 1) Any difference between the parties to the Contract of any nature arising out of or in connection with the Contract which could result in a claim by the Contractor against Canada, and which is not settled by consultation and co-operation as envisaged in GC8.2

CONSULTATION AND CO-OPERATION, shall be resolved in the first instance by Canada, whose written decision or direction shall be final and binding subject only to the provisions of GC8. Such written decision or direction includes, but is not limited to, any written decision or direction by Canada under any provision of the General Conditions.

- 2) The Contractor shall be deemed to have accepted the decision or direction of Canada referred to in paragraph 1) of GC8.3 and to have expressly waived and released Canada from any claim in respect of the particular matter dealt with in that decision or direction unless, within 15 working days after receipt of the decision or direction, the Contractor submits to Canada a written notice of dispute requesting formal negotiation under GC8.4 NEGOTIATION. Such notice shall refer specifically to GC8.4 NEGOTIATION, and shall specify the issues in contention and the relevant provisions of the Contract.
- 3) The giving of a written notice in accordance with paragraph 2) of GC8.3 shall not relieve the Contractor from complying with the decision or direction that is the subject of the dispute. Such compliance, however, shall not be construed as an admission by the Contractor of the correctness of such decision or direction.
- 4) If a dispute is not resolved promptly, Canada shall give such instructions as, in Canada's opinion, are necessary for the proper performance of the Work and to prevent delays pending a resolution of the matter. Unless Canada terminates the Contract, orders the Contractor to suspend the Work, or takes the Work out of the hands of the Contractor, the Contractor shall continue to perform the Work in accordance with the provisions and requirements of the Contract and the instructions of Canada. Such performance shall not prejudice any claim that the Contractor may have.
- 5) Nothing in GC8 relieves the Contractor from its obligation to provide any other notice required by the Contract within the time specified in the Contract, including but not limited to, any notice required under GC6.2 CHANGES IN SUBSURFACE CONDITIONS.

#### **GC8.4 NEGOTIATION**

- 1) Within 10 working days after receipt by Canada of a notice referred to in paragraph 2) of GC8.3 NOTICE OF DISPUTE, or within such other period of time as may be mutually agreed to, the parties shall commence formal negotiations in order to resolve the dispute. Negotiations shall occur initially between representatives of the Contractor and Canada who play a direct supervisory role in the performance, administration or management of the Contract.
- 2) If the representatives referred to in paragraph 1) of GC8.4 are unable to resolve some or all of the issues which are the subject of the negotiations within 10 working days, the parties shall refer the remaining issues which are in dispute to a second level of negotiation between a principal or principals of the Contractor and a senior level manager or senior level managers representing Canada.
- 3) If negotiations fail to resolve the dispute within 30 working days from the date of delivery of the notice referred to in paragraph 2) of GC8.3 NOTICE OF DISPUTE, or within such longer period as may have been agreed to by the parties, the Contractor may, by giving written notice to Canada, in accordance with GC2.3 NOTICES, within 10 working days from the end of such period, request that mediation be undertaken to assist the parties to reach agreement on the outstanding issues.
- 3) If the Contractor does not request mediation within the period permitted by paragraph 3) of GC8.4, the Contractor shall be deemed to have accepted the decision or direction of Canada under paragraph 1) of GC8.3 NOTICE OF DISPUTE and to have expressly waived and

released Canada from any claim in respect of the particular matter dealt with in that decision or direction.

### **GC8.5 MEDIATION**

- 1) If the Contractor has requested mediation in accordance with paragraph 3) of GC8.4 NEGOTIATION, mediation shall be conducted in accordance with GC8.8 RULES FOR MEDIATION OF DISPUTES.
- 2) If a Project Mediator has not previously been appointed for the purposes of the Contract, a Project Mediator shall be appointed in accordance with GC8.8 RULES FOR MEDIATION OF DISPUTES forthwith after delivery of a notice in accordance with paragraph 3) of GC8.4 NEGOTIATION, requesting mediation.
- 3) If the dispute has not been resolved within
  - (a) Ten (10) working days following the appointment of a Project Mediator in accordance with paragraph 2) of GC8.5, if a Project Mediator was not previously appointed;
  - (b) Ten (10) working days following receipt by Canada of a written notice in accordance with paragraph 3) of GC8.4 NEGOTIATION, if a Project Mediator was previously appointed; or
  - (c) such other longer period as may have been agreed to by the parties;

the Project Mediator shall terminate the mediation by giving written notice to the parties stating the effective date of termination.

### **GC8.6 BINDING ARBITRATION**

- 1) If mediation of the dispute is terminated pursuant to the provisions of GC8.5, "Mediation", and
  - a) the termination of mediation occurs prior to the applicable date set out in paragraph 4) of GC8.6; and
  - b) the disputed issues involve issues of fact or issues of arbitral questions of law or issues of mixed fact and arbitral questions of law;either party, by giving notice in writing to the other party in accordance with GC2.3, "Notices", may require that the dispute be resolved by binding arbitration pursuant to GC8.6.
- 2) A notice referred to in paragraph 1) of GC8.6 shall be given within 10 working days of the date of termination of mediation under GC8.5 Mediation and shall be in accordance with GC2.3, "Notices".
- 3) If no notice is given within the period set out in paragraph 2) of GC8.6, or if the conditions set out in subparagraphs 1)(a) and 1)(b) of GC8.6 are not met, the arbitration provisions set out in GC8.6 do not apply to the dispute.
- 4) Unless otherwise agreed, the arbitration of the dispute shall be held in abeyance until the earlier of
  - a) the date of issuance of a Certificate of Substantial Performance under GC5.5, "Substantial Performance of the Work";

- b) the date the Work is taken out of the Contractor's hands; and
- c) the date of termination of the Contract;

and consolidated with all other such disputes into a single arbitration.

- 5) Arbitral proceedings under this GC8.6 shall be governed by and conducted in accordance with the **Commercial Arbitration Act**, R.S. 1985, c. 17 (2nd Supp.) and the provisions of GC8.11, "Rules for Arbitration of Disputes".
- 6) For the purposes of calculating time under the Rules for Arbitration referred to in paragraph 5) of GC8.6, arbitration proceedings shall commence on the applicable date set out in paragraph 4) of GC8.6.
- 7) Notwithstanding anything else contained in GC8.6, the arbitration provisions in GC8.6 do not apply if the aggregate amount of all claims by the Contractor required to be arbitrated on the applicable date set out in paragraph 4) of GC8.6 is less than \$25,000.

#### **GC8.7 DISPUTES NOT SUBJECT TO ARBITRATION**

- 1) Where the arbitration provisions in GC8.6, "Binding Arbitration", do not apply to a dispute as a result of paragraphs 3) or 7) of GC8.6, "Binding Arbitration", either party may take such court action or proceedings as it considers appropriate, including, without limiting the foregoing, all suits that would otherwise have been immediately available to it but for the provisions of these Dispute Resolution Conditions. Subject to the provisions of paragraph 2) of GC8.7, the Contractor shall initiate any such action or proceeding no later than three calendar months after the date that a Certificate of Completion is issued under GC5.6, "Final Completion", and not afterwards, except where it is otherwise provided by law.
- 2) Any action or proceeding resulting from a direction under GC3.13, "Warranty and Rectification of Defects in Work", shall be initiated by the Contractor no later than three calendar months after the expiry of the warranty or guarantee period and not afterwards, except where it is otherwise provided by law.

#### **GC8.8 (2016-05-01) CONFIDENTIALITY**

All information exchanged during alternative dispute resolution procedures, by whatever means, shall be without prejudice and shall be treated as confidential by the parties and their representatives, unless otherwise required by law. However, evidence that is independently admissible or discoverable shall not be rendered inadmissible or non-discoverable by virtue of its use during an alternative dispute resolution process.

#### **GC8.9 (2016-05-01) SETTLEMENT**

Any agreement to settle all or any part of a dispute, by whatever means, shall be in writing and be signed by the parties or their authorized representatives.

#### **GC8.10 (2016-05-01) RULES FOR MEDIATION OF DISPUTES**

##### **GC8.10.1 Interpretation**

In these Rules

- 1) “Coordinator” means the person designated by Canada to act as the Dispute Resolution Coordinator.

#### **GC8.10.2 Application**

- 1) By mutual agreement, the parties may change or make additions to the Rules.

#### **GC8.10.3 Communication**

- 1) Written communications pursuant to these Rules shall be given in accordance with GC2.3 NOTICES.

#### **GC8.10.4 Appointment of Project Mediator**

- 1) The parties to the Contract may, by mutual consent, at any time after entry into the Contract, appoint a mediator (the “Project Mediator”) to conduct mediation proceedings in accordance with these Rules for Mediation of Disputes, in regard to any dispute that may arise with regard to the interpretation, application or administration of the Contract. In this case, they shall jointly enter into a contract with the appointed Project Mediator, which contract shall be in a form drafted by the Coordinator and agreed to by the parties.
- 2) If the parties do not appoint a Project Mediator pursuant to paragraph 1) of GC8.8.4, the parties shall appoint a Project Mediator within 17 working days following receipt of a written notice from the Contractor, in accordance with GC2.3 NOTICES, requesting that mediated negotiations be undertaken in accordance with these Rules to assist the parties to reach agreement on any outstanding issues that may be in dispute. Any contract entered into with the appointed Project Mediator shall meet the requirements as set out for the contract described in paragraph 1) of GC8.8.4.
- 3) When mediation is requested by the Contractor pursuant to paragraph 3) of GC8.4 NEGOTIATION, if the parties have previously entered into a contract with a Project Mediator, the parties shall within 2 days send to both the Project Mediator and the Coordinator
  - (a) a copy of the notice requesting negotiation under paragraph 2) of GC8.3 NOTICE OF DISPUTE;
  - (b) a copy of Canada’s written position in relation to the notice, the issues in contention and the relevant provisions of the contract; and
  - (c) a copy of the Contractor’s written request for mediation required under paragraph 3) of GC8.4 NEGOTIATION.
- 4) If the parties have not agreed on a Project Mediator, the parties shall forthwith provide the Coordinator with the written materials referred to in subparagraphs 3)(a), 3)(b) and 3)(c) of GC8.8.4 together with a request that the Coordinator assist in the appointment of a mutually acceptable Project Mediator in accordance with these Rules.
- 5) Within 5 working days following receipt of the request and materials referred to in paragraph 4) of GC8.8.4, the Coordinator shall provide the parties with a list of qualified private sector mediators obtained from an independent and impartial entity, together with instructions to

each party to individually and confidentially select and rank their preferred and fully acceptable choices of mediator in descending order. Each mediator listed shall be impartial and independent of the parties, and shall be an experienced and skilled commercial mediator, preferably with knowledge of the subject matter of the dispute.

- 6) Within 10 working days of receipt of the list referred to in paragraph 5) of GC8.8.4 each party shall comply with the instructions accompanying the list(s) and shall deliver the completed listing to the Coordinator.
- 7) Within 2 working days following receipt of the completed listings, the Coordinator shall select the highest common ranked mediator to act as Project Mediator for the purposes of the contract.
- 8) In the event of a tie, the Coordinator shall consult both parties to re-evaluate their rankings in order to assist the Coordinator in selecting a Project Mediator acceptable to both parties. If the parties cannot agree upon a Project Mediator, the Coordinator shall forthwith provide the parties with a second list of mediators and the procedure shall be repeated.
- 9) If the parties have not previously entered into a contract with a mutually acceptable Project Mediator, the Coordinator shall use reasonable efforts to negotiate a contract with a mutually acceptable Project Mediator on behalf of the parties, which contract shall incorporate or otherwise comply with the provisions of these Rules. If negotiations are unsuccessful, or if for other reason the individual is unwilling or unable to enter into a contract to act as Project Mediator, the Coordinator shall repeat the process with the second-highest common ranked mediator.
- 10) The parties agree that, upon successful completion of the negotiations referred to in paragraph 9) of GC8.8.4, they shall jointly enter into a contract with the selected Project Mediator, which contract shall be in a form drafted by the Coordinator and agreed to by the parties.
- 11) Upon execution of the contract with the Project Mediator referred to in paragraph 10) of GC8.8.4 the Coordinator shall provide the Project Mediator with copies of the documents referred to in paragraph 3) of GC8.8.4.

#### **GC8.10.5 Confidentiality**

- 1) Subject to paragraph 2) of GC8.8.5, and unless otherwise agreed in writing by the parties, the Project Mediator, the parties and their counsel or representatives shall keep confidential all matters and documents disclosed during mediation proceedings except where the disclosure is necessary for any implementation of any agreement reached or is required by law.
- 2) Evidence that is independently admissible or discoverable in any arbitral or judicial proceeding shall not be rendered inadmissible or non-discoverable by virtue of its use in mediation proceedings.
- 3) Neither party shall make transcripts, minutes or other records of a mediation conference.
- 4) The personal notes and written opinions of the Project Mediator made in relation to mediation are in the Project Mediator's sole possession and control, are confidential, and may not be used in any subsequent proceeding between the parties or where they are opposed in interest without the express written permission of the parties.

- 5) All information exchanged during mediation procedures, by whatever means, shall be without prejudice and shall be treated as confidential by the parties and their representatives, unless otherwise required by law.

**GC8.10.6 Time and Place of Mediation**

- 1) The Project Mediator, in consultation with the parties shall set the date, time and place of any mediation conference as soon as possible, bearing in mind that, subject to agreement to the contrary between the parties, only 10 working days are available within which to attempt to settle the dispute.

**GC8.10.7 Representation**

- 1) Representatives of the parties may be accompanied at the mediation conference by legal counsel or any other person.
- 2) If the Project Mediator is a lawyer, the Project Mediator shall not provide legal advice to a party during the course of the mediation conference, but may recommend that a party obtain independent legal advice before finalizing a settlement agreement.

**GC8.10.8 Procedure**

- 1) The parties agree to an exchange of all facts, information and documents upon which they intend to rely in any oral or written presentation during the mediation. This exchange shall be completed no later than 2 working days prior to the date set for a mediation conference.
- 2) The Project Mediator shall be free to meet with the parties individually during a mediation conference if the Project Mediator is of the opinion that this may improve the chances of a mediated settlement, and either party may request such an individual meeting at any time.
- 3) The parties may agree to extend the 10 working days available for settlement of the dispute through mediation, and the Project Mediator shall record that agreement in writing.

**GC8.10.9 Settlement Agreement**

- 1) The parties shall record in writing any settlement agreement reached, with sufficient detail to ensure a clear understanding of
  - (a) the issues resolved;
  - (b) any obligations assumed by each party including criteria to determine if and when these obligations have been met; and
  - (c) the consequences of failure to comply with the agreement reached.
- 2) The parties agree to carry out the terms of a settlement agreement as soon as possible and, in any event, within any time periods specified in the agreement.

**GC8.10.10 Termination of Mediation**



- 1) Either party may withdraw from mediation at any time without reason and, in that event, the Project Mediator shall give each party a written notice terminating the mediation and establishing the effective date of termination.
- 2) If, in the opinion of the Project Mediator, either party fails to mediate in good faith or fails to comply with the terms of these Rules, or if the Project Mediator, at any time during mediation, is of the opinion that further negotiations will fail to resolve the issues outstanding, the Project Mediator may terminate the negotiations by providing the parties with a written notice of termination, stating therein the Project Mediator's reasons for the termination, and the effective date of termination.
- 3) If a dispute has not been resolved within 10 working days or such other longer period as may have been agreed to by the parties, the Project Mediator shall terminate the mediation by giving written notice to the parties stating the effective date of termination.

#### **GC8.10.11 Costs**

- 1) The parties agree that they will each be responsible for the costs of their own representatives and advisors and associated travel and living expenses. Fees and expenses of the Project Mediator and all administrative costs of mediation, such as the cost of the meeting room(s), if any, shall be borne equally by the parties.

#### **GC8.10.12 Subsequent Proceedings**

- 1) The parties shall not rely on or introduce as evidence in any arbitral or judicial proceeding, whether or not such proceeding relates to the subject matter of mediation,
  - (a) any documents of other parties that are not otherwise producible in those proceedings;
  - (b) any views expressed or suggestions made by any party in respect of a possible settlement of issues;
  - (c) any admission made by any party in the course of mediation unless otherwise stipulated by the admitting party; and
  - (d) the fact that any party has indicated a willingness to make or accept a proposal or recommendation for settlement.
- 2) The Project Mediator shall neither represent nor testify on behalf of either of the parties in any subsequent investigation, action or proceeding relating to the issues in mediation proceedings.
- 3) The Project Mediator shall not be subpoenaed to give evidence relating to
  - (a) the Project Mediator's role in mediation; or
  - (b) the matters or issues in mediation;**

**in any subsequent investigation, action or proceeding and the parties agree to vigorously oppose any effort to have the Mediator so subpoenaed.**

**GC9 CONTRACT SECURITY**

GC9.1 OBLIGATION TO PROVIDE CONTRACT SECURITY

GC9.2 TYPES AND AMOUNTS OF CONTRACT SECURITY

**GC9.1 OBLIGATION TO PROVIDE CONTRACT SECURITY**

- 1) The Contractor shall, at the Contractor's expense and within 14 days after the date that the Contractor receives notice that the Contractor's bid was accepted by Canada, obtain and deliver Contract Security to Canada in one of the forms prescribed in GC9.2 TYPES AND AMOUNTS OF CONTRACT SECURITY.
- 2) If the whole or a part of the Contract Security provided is in the form of a security deposit, it shall be held and disposed of in accordance with GC5.13 RETURN OF SECURITY DEPOSIT and GC7.4 SECURITY DEPOSIT - FORFEITURE OR RETURN.
- 3) If a part of the Contract Security provided is in the form of a labour and material payment bond, the Contractor shall post a copy of that bond at the site of the Work.
- 4) It is a condition precedent to the release of the first progress payment that the Contractor has provided the Contract Security as specified herein.

**GC9.2 (2016-05-01) TYPES AND AMOUNTS OF CONTRACT SECURITY**

- 1) The Contractor shall deliver to Canada either (a) or (b).
  - a) A performance bond and a labour and material payment bond each in an amount that is equal to not less than 50 percent of the Contract Amount (excluding applicable tax(es)).
  - b) A security deposit or an irrevocable standby letter of credit in an amount that is equal to not less than 20 percent of the Contract Amount (excluding applicable tax(es)).
- 2) A performance bond and a labour and material payment bond referred to in paragraph 1) of GC9.2 shall be in a form and be issued by a bonding or surety company that is approved by Canada.
  - (a) The approved form for the performance bond is displayed at the following Website: <http://www.tbs-sct.gc.ca/pol/doc-eng.aspx?id=14494&section=text#appS>
  - (b) The approved form for the labour and material payment bond is displayed at the following website: <http://www.tbs-sct.gc.ca/pol/doc-eng.aspx?id=14494&section=text#appS>; and
  - (c) The list of approved bonding or surety companies is displayed at the following Website: <http://www.tbs-sct.gc.ca/pol/doc-eng.aspx?id=14494&section=text#appl>
- 3) A security deposit referred to in subparagraph 1)(b) of GC9.2 shall be in the form of
  - a. a bill of exchange, bank draft or money order made payable to the Receiver General for Canada and certified by an approved financial institution or drawn by an approved financial institution on itself; or

- b. bonds of, or unconditionally guaranteed as to principal and interest by, the Government of Canada.
- 4) For the purposes of subparagraph 3)(a) of GC9.2
- a) a bill of exchange is an unconditional order in writing signed by the Contractor and addressed to an approved financial institution, requiring the said institution to pay, on demand, at a fixed or determinable future time a sum certain of money to, or to the order of, the Receiver General for Canada;
  - b) if a bill of exchange, bank draft or money order is certified by or drawn on an institution or corporation other than a chartered bank, it must be accompanied by proof that the said institution or corporation meets at least one of the criteria described in subparagraph 4)(c) of GC9.2, either by letter or by a stamped certification on the bill of exchange, bank draft or money; and
  - c) An approved financial institution is
    - I.a corporation or institution that is a member of the Canadian Payments Association as defined in the [Canadian Payments Act](#);
    - II.a corporation that accepts deposits that are insured, to the maximum permitted by law, by the Canada Deposit Insurance Corporation or the "Autorité des marchés financiers";
    - III.a corporation that accepts deposits from the public if repayment of the deposit is guaranteed by Her Majesty the Queen in right of a province;
    - IV.a corporation, association or federation incorporated or organized as a credit union or co-operative credit society that conforms to the requirements of a credit union which are more particularly described in paragraph 137(6) of the [Income Tax Act](#); or
    - V.Canada Post Corporation.
- 5) Bonds referred to in subparagraph 3)(b) of GC9.2 shall be provided on the basis of their market value current at the date of the Contract, and shall be
- a) made payable to bearer; or
  - b) accompanied by a duly executed instrument of transfer of the bonds to the Receiver General for Canada in the form prescribed by the Domestic Bonds of Canada Regulations; or
  - c) registered as to principal, or as to principal and interest, in the name of the Receiver General for Canada pursuant to the Domestic Bonds of Canada Regulations.
- 6) An irrevocable standby letter of credit referred to in subparagraph 1)(b) of GC9.2 shall
- a) be an arrangement, however named or described, whereby a financial institution (the "Issuer") acting at the request and on the instructions of a customer (the "Applicant") or on its own behalf,
    - I.is to make a payment to, or to the order of, Canada as the beneficiary;
    - II.is to accept and pay bills of exchange drawn by Canada;

III. authorizes another financial institution to effect such payment or accept and pay such bills of exchange; or

IV. authorizes another financial institution to negotiate against written demand(s) for payment provided that the terms and conditions of the letter of credit are complied with;

- b) state the face amount that may be drawn against it;
- c) state its expiry date;
- d) provide for sight payment to the Receiver General for Canada by way of the financial institution's draft against presentation of a written demand for payment signed by Canada;
- e) provide that more than one written demand for payment may be presented subject to the sum of those demands not exceeding the face value of the letter of credit;
- f) provide that it is subject to the International Chamber of Commerce (ICC) Uniform Customs and Practice (UCP) for Documentary Credits, 2007 Revision, ICC Publication No. 600. Pursuant to the ICC UCP, a credit is irrevocable even if there is no indication to that effect; and
- g) be issued or confirmed, in either official language in a format left to the discretion of the issuer or confirmer, by an approved financial institution on its letterhead.

**GC10 INSURANCE**

GC10.1 INSURANCE CONTRACTS

GC10.2 INSURANCE PROCEEDS

**GC10.1 INSURANCE CONTRACTS**

- 1) The contractor shall, at the contractor's expense, obtain and maintain insurance contracts in respect of the work and shall provide evidence thereof to Canada in accordance with the requirements of the INSURANCE TERMS.
- 2) The insurance contracts referred to in paragraph 1) of GC10.1 shall
  - (a) be in a form, of the nature, in the amounts, for the periods and containing the terms and conditions specified in INSURANCE TERMS; and
  - (b) provide for the payment of claims under such insurance contracts in accordance with GC10.2 INSURANCE PROCEEDS.

**GC10.2 INSURANCE PROCEEDS**

- 1) In the case of a claim payable under a Builders Risk/Installation (All Risks) insurance contract maintained by the contractor pursuant to GC10.1 INSURANCE CONTRACTS, the proceeds of the claim shall be paid directly to Canada, and
  - (a) the monies so paid shall be held by Canada for the purposes of the contract, or
  - (b) if Canada elects, shall be retained by Canada, in which event they vest in Canada absolutely.
- 2) In the case of a claim payable under a General Liability insurance contract maintained by the contractor pursuant to GC10.1 INSURANCE CONTRACTS, the proceeds of the claim shall be paid by the insurer directly to the claimant.
- 3) If an election is made pursuant to paragraph 1) of GC10.2, Canada may cause an audit to be made of the accounts of the contractor and of Canada in respect of the part of the work that was lost, damaged or destroyed for the purpose of establishing the difference, if any, between
  - (a) the aggregate of the amount of the loss or damage suffered or sustained by Canada, including any costs incurred in respect of the clearing and cleaning of the work and its site and any other amount that is payable by the contractor to Canada under the contract, minus any monies retained pursuant to subparagraph 1)(b) of GC10.2; and
  - (b) the aggregate of the amounts payable by Canada to the contractor pursuant to the contract up to the date of the loss or damage.
- 4) A difference that is established pursuant to paragraph 3) of GC10.2 shall be paid forthwith by the party who is determined by the audit to be the debtor to the party who is determined by the audit to be the creditor.

- 5) When payment of a deficiency has been made pursuant to paragraph 4) of GC10.2, all rights and obligations of Canada and the contractor under the contract shall, with respect only to the part of the work that was the subject of the audit referred to in paragraph 3) of GC10.2, be deemed to have been expended and discharged.
- 6) If an election is not made pursuant to subparagraph 1)(b) of GC10.2, the contractor shall, subject to paragraph 7) of GC10.2, clear and clean the work and its site and restore and replace the part of the work that was lost, damaged or destroyed at the contractor's expense as if that part of the work had not yet been performed.
- 7) When the contractor clears and cleans the work and its site and restores and replaces the work referred to in paragraph 6) of GC10.2, Canada shall pay the contractor out of the monies referred to in paragraph 1) of GC10.2 so far as they will thereunto extend.
- 8) Subject to paragraph 7) of GC10.2, payment by Canada pursuant to paragraph 7) of GC10.2 shall be made in accordance with the contract but the amount of each payment shall be 100 percent of the amount claimed notwithstanding subparagraphs 3)(a) and 3)(b) of GC5.4 PROGRESS PAYMENT.



## **Appendix "E"**

### **SPÉCIFICATIONS AND PLANS**

**TECHNICAL SPECIFICATIONS  
ISSUED FOR BID**

**STORM DRAINAGE IMPROVEMENT WORKS**

**FRELIGHSBURG EXPERIMENTAL FARM**

GEN20-1006  
August 17<sup>th</sup>, 2020

Prepared by :



2031 rue Léonard-De Vinci suite 100  
Sainte-Julie (Québec) J3E 1Z2

Prepared by :



A handwritten signature in blue ink, appearing to read "Annie Calgaro", is positioned above a horizontal line.

Annie Calgaro, CPI  
OIQ143549

---

Stéphane Bélanger, eng.  
OIQ110490



**Documents list**

<b>SECTION 1</b>	<b>TENDER FORM</b>
<b>1.1</b>	<b>BID SCHEDULE</b>
<b>1.2</b>	<b>DESCRIPTION OF THE BID ITEM</b>
<b>SECTION 2</b>	<b>GENERAL AND PARTICULAR TECHNICAL CLAUSES</b>
<b>SECTION 3</b>	<b>PICTURES OF THE SITE</b>

# **SECTION 1**

**Bidding forms**



**DRAINAGE IMPROVEMENT - FRELIGHSBURG EXPERIMENTAL FARM  
FRELIGHSBURG**

**PRICE SCHEDULE**

---

**Summary**

---

**PRICES**

**PROPOSED WORK**

- 1,0 Aqueduct
- 2,0 Storm water sewer
- 3,0 Road works

_____
_____
_____
_____
_____
_____
_____
_____

**SUB-TOTAL**

G.S.T. 5 %

Q.S.T. 9,975 %

**TOTAL**



**DRAINAGE IMPROVEMENT - FRELIGHSBURG EXPERIMENTAL FARM  
FRELIGHSBURG**

Projet : GEN20-1002

**PRICE SCHEDULE**

ART.	DESCRIPTION	QTY approx.	UNIT.	UNIT PRICE	TOTAL
<b>1,0 Aqueduct</b>					
1,1	Relocation of the drinking water pumping station tank including all necessary connections and accessories	1	global	_____	_____
1,2	Water pipe diameter 50 mm in K sorft type copper including valves, service box, cathodic protection, electrical pipe, excavation and backfill.	72	m. lin.	_____	_____
1,3	Leak test, cleaning and disinfection of aqueduct pipes	72	m.lin.	_____	_____
				<b>Sub Total (1.0)</b>	_____



**PRICE SCHEDULE**

<b>ART.</b>	<b>DESCRIPTION</b>	<b>QTY approx</b>	<b>UNIT.</b>	<b>UNIT PRICE</b>	<b>TOTAL</b>
<b>2,0</b>	<b>Storm water sewer</b>				
2,1	Storm water conduct in reinforced concrete sewer line with rubber joints including rubber fittings (BNQ 2622-120), excavation and backfill. For pipes diameter 300 mm and less, PVC DR-35 is accepted as equivalent				
	- 200 mm	6	m.lin.	_____	_____
	- 300 mm	39	m.lin.	_____	_____
	- 375 mm	22	m.lin.	_____	_____
	- 450 mm	38	m.lin.	_____	_____
2,2	Cleaning and video inspection of the storm sewer system				
	- provisional acceptance	105	m.lin.	_____	_____
	- upon final acceptance	105	m.lin.	_____	_____
2,3	Drainage trench including all elements of cross section plans	10	m.lin.	_____	_____
2,4	Prefabricated storm sewer manholes with Lécuyer rubber gaskets or approved equivalent, including a safety grid for manholes deeper than 3 meters (BNQ 2622-400), a Tex-O-Flex 40-12 type geomembrane Texel, adjustable frame and buffer, bedding, embedding, excavation and backfilling				
	- Model P-1200	1	unit	_____	_____
2,5	Prefabricated P4 catch basin with Lécuyer rubber gaskets or approved equivalent, a Tex-O-Flex 40-12 type geomembrane from Texel, adjustable frame and buffer, bedding, encasement, excavation and backfill	2	unit	_____	_____
2,6	Connection to the existing catch basin including the BNQ box, drilling, replacing 1 meter of the rings and replacing the head	1	unit	_____	_____
2,7	HDPE catch basin (for gutters) diameter 450 mm including connection to the network	4		_____	_____
2,8	Storm water outlet including the clean stones, etc.	1	global	_____	_____
				<b>Sub total 2.0</b>	_____



**PRICE SCHEDULE**

ART.	DESCRIPTION	QTY approx.	UNIT.	UNIT PRICE	TOTAL
<b>3 Road works</b>					
3,1	Demolition of water pipes, storm water pipes, paving, etc.	1	global	_____	_____
3,2	Preparation of the infrastructure; 2nd class material clearing including removal, transport and off-site disposal of soils and materials up to the level of the proposed street infrastructure, addition of borrow material up to the level of the street infrastructure if necessary, stripping topsoil and backfilling existing ditches to proposed levels with borrow material.	750	m <sup>2</sup>	_____	_____
3,3	Geomembrane Texel 7612 including supply and installation	750	m <sup>2</sup>	_____	_____
3,4	Sub foundation MG-56 type crushed stone or MR-1 or MR-2 recycled materials including installation, leveling and compaction - 350 mm thick	750	m <sup>2</sup>	_____	_____
3,5	Foundation MG-20 type crushed stone including spreading, leveling and compaction - 150 mm thick	750	m <sup>2</sup>	_____	_____
3,6	Paving including structural adjustment, bonding binder, installation, leveling and compaction - layer, 70 mm thick, type ESG-10	750	m <sup>2</sup>	_____	_____
3,7	Site organization	1	global	_____	_____
3,8	Pavement sawing	1	global	_____	_____
3,9	Sodding	1	global	_____	_____
				<b>Sub total 3.0</b>	_____

## **1.2 Description of tender form**

This section provides a brief description of the tender forms items and specifies the methods of payment for all items on the form. The Contractor's method of payment is established under the conditions described in the general and specific administrative and technical clauses. The payment methods below prevail over the payment methods mentioned in the various sections of the quote.

Payment of the unit and/or inclusive prices indicated on the tender form by the Contractor will constitute full compensation for the supply of materials, equipment, accessories, machinery, tools and labor which will be necessary to carry out the corresponding work.

Administration costs, profits, transport, all charges and expenses, mobilization and demobilization costs, direct and indirect costs, taxes, customs duties, overheads, incidentals and all other expenses resulting from the obligations imposed on the Contractor in the tender documents and which are necessary for the performance of the corresponding work.

Unit and/or inclusive prices include trenching or mass excavation and excavation when such work is required, removal of shrubs, brush, scrap, digging both by hand and by machine, pumping and shoring required, backfilling with excavation materials deemed acceptable and compaction, transport, storage and, if necessary, spreading of unused or unacceptable materials outside the site of the construction site in a place chosen by the Contractor, the support of existing services and works, the diversion of ditches, culverts, sewers and drains, the protection of services, legal and / or geodetic landmarks, existing developments to be preserved, temporary service roads and signage, dust suppressant, leveling and cleaning.

They also include the bedding and coating of the pipes, backfilling of trenches with granular materials and thermal insulation, when such work is required, including the supply, transport, placement and compacting of these materials, in accordance with the requirements of the "Tender Documents".

The prices tendered must include the cost of minor works which, although they are not specified in the contractual documents, are usual and necessary for the completion of the various works required by the contract so that these works comply with the use for which they are destined.

### **Articles Description:**

#### **1.0 AQUEDUCT**

In the article entitled "**RELOCATION OF THE PUMPING STATION ...**", the Contractor must include in the **global price**, including but not limited to:

- a) Dismantling of the reservoir and its components
- b) Transportation of equipment;
- c) The installation of the tank and its components;
- d) The necessary electrical components.

- e) Supply and installation of all necessary accessories.

All as specified in the plans and specifications.

In the article entitled "**WATER CONDUCT ...**", the Contractor must include in the price per **linear meter**, depending on the diameter, including but not limited to:

- a) The excavation;
- b) Propping, support of the trench, water control and pumping;
- c) Compaction, filling;
- d) Backfilling;
- e) Supplying and putting in place borrow material when required;
- f) Supplying and installation of the aqueduct pipe, from the well to the main building (connections included);
- g) The supplying and installation of all the accessories necessary for the connection of the aqueduct pipe;
- h) The preparation and installation of the bedding;
- i) Compaction;
- j) Cathodic protection of the service connection;
- k) Testing; and
- l) The transport and disposal of excess excavation and / or waste in a site authorized by the MELCC, etc.

All as specified in the plans and specifications.

In the article entitled "**LEAK TEST, CLEANING AND DISINFECTION ...**" the Contractor must include in the **price per linear meter**, for all aqueduct work, including but not limited to:

- a) The cleaning plan;
- b) Cleaning, torpedo passage, testing and disinfection, depending on the diameter;
- c) The supply and transport of water, when required;
- d) Correcting defects and resuming the aforementioned activities in the event of non-compliance;
- e) Purges, when required; and
- f) A detailed report produced by a firm accepted by the Project Manager in three (3) copies.

All as specified in the plans and specifications.

## 2.0 STORM SEWER

In the section entitled "**STORM WATER PIPE ...**", the Contractor must include at the price per linear meter, depending on the diameter, type of pipe and type of trench indicated, including but not limited to:

- a) Excavation of the trenches;
- b) Propping, trench support, water control, pumping, and protection of HQ poles near the work if required;



- c) The filling, backfilling, supply and placement of borrow material, when required;
- d) Supply and installation of the bedding, compaction;
- e) Supply and installation of the pipe with watertight joints;
- f) Compaction;
- g) Tees and plugs required including the connections to the pipes and the supply for sealing the joints;
- h) Strength tests;
- i) The transport and disposal of excess excavation and / or waste in a site authorized by the MELCC, etc.

All as specified in the plans and specifications.

In the section entitled " **CLEANING AND VIDEO INSPECTION ...**", the Contractor must include in the price per **linear meter** depending on the diameter and material, including but not limited to:

- a) A cleaning and inspection plan;
- b) Water control and pumping;
- c) Cleaning;
- d) Video inspection and passing the profilometer including the supply of two (2) copies of the report and videos cassettes, CD or DVD with index;
- e) Disposal of waste in an authorized site;
- f) Correction of defects and resumption of the above activities in the event of non-compliance;
- g) For payment purposes, the method of measurement meets the requirements of the article entitled "Storm water pipe ...".

All as specified in the plans and specifications.

In the section entitled "**DRAINING TRENCH ...**" the Contractor must include in the price per **linear meter**, depending on the type of drain, including but not limited to:

- a) Supply and installation of the drain to the sump;
- b) All necessary accessories;
- c) Excavation, placement of clean stone, geotextile, and river stone;
- d) Supply and installation of the chimney;
- e) The transport and disposal of excess excavation and / or waste in a site authorized by the MELCC, etc.

All as specified in the plans and specifications.

In the section entitled "**PREFABRICATED STORM WATER MANHOLE**", the Contractor must include at the **unit price**, depending on the type of manhole, including but not limited to:

- a) Excavation of the trenches;
- b) Propping, trench support, water control, pumping, and protection of HQ poles near the work;
- c) Supplying and installation of prefabricated manholes according to the type indicated;

- d) The cunet, the slab, etc .;
- e) The required joints with the appropriate gaskets;
- f) All the specified accessories, including a granite cunette, when required as well as the frame and the buffer, the safety landing, etc .;
- g) Tex-O-Flex geomembrane with granular coating;
- h) All excavation, compaction, stone filling and backfilling;
- i) Cleaning the bottom of the manhole; and
- j) The transport and disposal of excess excavation and / or waste in a site authorized by the MELCC, etc.;
- k) Leak tests.
- l) All as specified in the plans and specifications.

In the section entitled "**PREFABRICATED P4 CATCH BASIN**", the Contractor must include in the **unit price**, depending on the type of sump, including but not limited to:

- a) Supplying and installation of the Lécuyer type catch basin, the slabs and the connection pipe to the storm sewer;
- b) All necessary accessories such as grille, hatch, head, watertight gaskets, etc.;
- c) All excavation, bedding, compaction, backfilling up to the infrastructure line and stone filling;
- d) Tex-O-Flex geomembrane with granular coating;
- e) Supplying and installation of the geotextile membrane;
- f) Installation of pipes to drain the foundation;
- g) Frames and grids adjusted to the final profile (2 adjustments); and
- h) The transport and disposal of excess excavation and / or waste in a site authorized by the MDDELCC, etc.

All as specified in the plans and specifications.

In the section entitled "**CONNECTION TO EXISTING CATCH BASIN ...**", the Contractor must provide at the **unit price**, depending on the type of trench, the type of pipe and the diameter indicated, including but not limited to:

- a) All connections of the planned pipes to the existing network including all required accessories;
- b) Drilling of the BNQ box;
- c) Excavation and backfilling of trenches;
- d) Replacing 1 meter of the catch basin ring;
- e) Replacing catch basin head;
- f) The filling, backfilling, supply and placement of borrow material, when required;
- g) The repair of surfaces damaged by the work, including the shoulder and the foundation and street paving as existing;
- h) The transport and disposal of excess excavation and / or waste in a site authorized by the MELCC, etc.;

All as specified in the plans and specifications.

In the article entitled "**HDPE CATCH BASIN**" the Contractor must include in the **unit price**, depending on the type of sump, including but not limited to:

- a) Supplying and installation of Soleno HDPE catch basins and connection to the storm sewer;
- b) All necessary accessories such as grille, hatch, head, watertight gaskets, etc. ;
- c) All excavation, bedding, compaction, backfilling up to the infrastructure line and stone filling;
- d) The frames and grids adjusted to the final profile; and
- e) The transport and disposal of excess excavation and / or waste in a site authorized by the MELCC, etc.

All as specified in the plans and specifications.

In the section entitled "**STORM WATER OUTLET...**", the Contractor must include in the **global price** according to the type of materials required and their thickness, including but not limited to:

- a) Supplying and installation of the various granular materials and geotextile requested;
- b) Leveling, compaction and transport; and
- c) Final shaping, etc.

All as specified in the plans and specifications.

### 3.0 Road way

In the article entitled "**DEMOLITION ...**", the Contractor must include in the **global price**, but not be limited to:

- a) Topsoil Stripping if required;
- b) The demolition of the storm water pipes and aqueduct pipes;
- c) Demolition of paving and other surfaces;
- d) Transport and disposal of waste in a site authorized by the MELCC, etc.

All as specified in the plans and specifications.

In the section entitled "**INFRASTRUCTURE PREPARATION AND SHAPING ...**", the Contractor must include in the **price per square meter** including but not limited to:

- a) Preparation and shaping of the infrastructure; excavation of 2nd class materials and topsoil up to the level of the street infrastructure proposed on the plan;
- b) Transport and disposal of waste in a site authorized by the MELCC, etc.

All as specified in the plans and specifications.

In the section entitled "**GEOMAMBRANE**", the Contractor must include in the **price per square meter**, including, but not limited to:

- a) Labor, equipment and materials necessary for the placement of the geotextile;
- b) Any loss of the geotextile for overlapping the work infrastructure. Meaning that the Contractor is paid per theoretical square meter of the area to be covered with the geotextile.

All as specified in the plans and specifications.

In the section entitled "**SUB FOUNDATION ...**", the Contractor must include in the **price per square meter**, but not limited to:

- a) Supplying and installation of the MG-56 crushed stone or recycled materials of type MR1, MR2 (NQ2560-600) thickness of 350 mm for the paving;
- b) Leveling of the granular layer according to the proposed levels;
- c) 95% compaction of the modified proctor and leveling.
- d) Making transitions with existing street structures;

All as specified in the plans and specifications.

In the section entitled "**FOUNDATION ...**", the Contractor must include in the **price per square meter**, but not limited to:

- a) Supplying and installation of the MG-20 crushed stone, thickness of 150 mm for paving;
- b) Leveling of the granular layer according to the proposed levels;
- c) 95% compaction of the modified proctor;
- d) Making transitions with existing street structures;

All as specified in the plans and specifications.

In the section entitled "**PAVING ...**", the Contractor must include in the price per **square meter** according to the mixing price, the thickness and the execution period including, but not limited to:

- a) Sawing the paving at the joint location;
- b) Leveling of the paving for connection;
- c) Supplying and application of bonding agent between new surfaces and existing ones;
- d) The supply and installation of the asphalt according to the required mixture;
- e) Adjustment of existing and planned structures;
- f) Cleaning;
- g) Connection to the existing pavement;
- h) Correction of the bituminous coating before the second layer;
- i) Making and removing chamfers where required on the base layer;
- j) Samples to be provided and the location around the existing structures;
- k) Emulsion around structures;
- l) Compaction.

All as specified in the plans and specifications.

In the article entitled "**SITE ORGANIZATION**", the Contractor must include in the **global price**, but not limited to:

- a) The application of administrative clauses;
- b) Coordination with subcontractors and various stakeholders;
- c) Sanitary installation;
- d) Detour roads, signage and other necessary measures;
- e) Temporary fences if necessary (installation and dismantling supply).

All as specified in the plans and specifications.

In the section entitled "**PAVEMENT SAWING**", the Contractor must include in the **global price**, but not limited to:

- a) Cleaning the roadway;
- b) Pavement sawing.

All as specified in the plans and specifications.

In the articles entitled "**SODDING**", the Contractor must include in the **global price**, but not limited to:

- a) Supplying and placement of topsoil - minimum 150 mm thick - amended according to the specifications of the quotes;
- b) Fertilizers;
- c) Removing all waste and all stones with a diameter of 25 mm and more;
- d) Work necessary to bring the materials into conformity;
- e) Lawn sodding according to the slope of the land;
- f) Watering and lawn protection during the warranty period;
- g) General turf maintenance including replacement of damaged turf; and
- h) The re-grassing of portions of surfaces covered by less than 75% of shoots with a height of 150 mm.

All as specified in the plans and specifications.

# **SECTION 2**

**GENERAL AND PARTICULAR TECHNICAL CLAUSES**

## Table of Contents

<b>TECHNICAL SPECIFICATIONS</b> .....	<b>1</b>
1.2 Description of tender form.....	1
1.0 NATURE OF THE WORK.....	1
2.0 Sanitary facilities installation.....	1
3.0 Drinking water cutoff.....	1
4.0 Generality.....	2
4.1 SPECIAL QUOTE.....	2
4.2 MATERIALS.....	2
4.3 SITE ORGANIZATION.....	2
4.4 CLEANING.....	2
5.0 EXCAVATIONS AND BACKFILL.....	2
5.1 FILLING AROUND THE STRUCTURES.....	2
5.2 SLOPE STABILITY AND EXCAVATION.....	2
5.3 LOSS OF VOLUME MASS AND SOIL REHABILITATION.....	2
5.4 CONTAMINATED MATERIAL.....	3
6.0 City Water.....	3
6.1 GENERAL.....	3
6.2 PIPES.....	3
6.2.1 LOCATOR WIRE.....	3
6.2.2 Connecting.....	3
6.2.3 CONNECTION SLEEVE.....	4
6.2.4 SERVICE BOX.....	4
6.2.5 CONNECTION VALVES.....	5
6.3 WATER SUPPLIES AND ACCESSORIES.....	5
6.4 WATER RECOVERY.....	5
6.5 CATHODIC PROTECTION OF THE VALVES AND THE SET OF FIRE TERMINALS... 5	5
6.5.1 CHARACTERISTICS OF ZINC ANODES.....	5
6.5.2 Type.....	6
6.5.3 INSTALLATION PROCEDURE.....	6
6.6 DIVERSION OF AQUEDUC.....	7
6.7 CERTIFICATION AND COMPETENCE OF LABOR.....	8
6.8 RELOCATION OF THE WATER PUMPING STATION.....	8
7.0 SEWER.....	10
7.1 GENERAL.....	10
7.2 SPILL OF WASTEWATER INTO THE ENVIRONMENT.....	10
7.3 DOMESTIC SEWER PIPES.....	10
7.4 RAIN SEWER PIPES.....	10
7.5 TEX-O-FLEX MEMBRANE.....	10
7.6 MANHOLE.....	11
7.7 FRAMES AND LIDS OF MANHOLE, MANHOLE AND KEY MOUTH.....	11
7.8 PREFABRICATED catch basin.....	12
7.9 HDPE Catch Basin.....	12
7.10 PROTECTION OF THE WATERMAIN.....	12
8.0 FOUNDATION AND PAVING.....	13
8.1 GENERAL CONDITION.....	13
8.2 SCOPE OF WORK.....	13
8.3 AGGREGATES AND ASPHALT.....	13

8.4	Foundation.....	13
8.4.1	Putting in place AND COMPACTION OF THE foundation.....	13
8.4.2	CONSTITUENT LAYER.....	14
8.4.3	FOUNDATION TRANSITION.....	14
8.4.4	MAINTENANCE AND DECONTAMINATION.....	14
8.4.5	CRUSHED STONE.....	14
8.4.6	ACCEPTANCE OF THE LOT.....	14
8.4.7	REJECTION OF A LOT.....	14
8.4.8	REVISED PRICE DURING NON-CONFORMITY.....	15
8.4.9	CONTRACTOR'S Recourse.....	15
8.4.10	CHANGES of ALIGNMENTS OR PROFILES.....	16
8.4.11	INFRASTRUCTURE STABILITY.....	16
8.5	PAVING.....	16
8.5.1	TERMS AND CONDITIONS.....	16
8.5.2	GENERAL SPECIFICATIONS AND SPECIFICATIONS (CCDG).....	17
8.5.3	ADJUSTING PUBLIC SERVICE PARTS.....	17
8.5.4	REPLACEMENT OF MANHOLE SECTION.....	17
8.5.5	VALVE BOX REPLACEMENT.....	18
8.5.6	REPLACEMENT OF FRAMEWORK.....	18
8.5.7	REPLACEMENT OF the catch basin's HEAD.....	18
8.5.8	ELEVATIONS AND LOCATIONS.....	19
8.5.9	CHANGE TO ALIGNMENTS OR PROFILES.....	19
8.5.10	CONNECTION WITH EXISTING PAVING.....	19
8.5.11	BITUMINOUS COATING.....	19
8.5.12	MIXTURE FORMULA.....	20
8.5.13	ACCEPTANCE OF THE CONSTITUENTS OF BITUMINOUS MIXTURES.....	20
8.5.14	ACCEPTANCE OF BITUMINOUS MIXTURE FORMULAS.....	20
8.5.15	SITE APPROVAL.....	21
8.5.16	FINAL APPROVAL.....	21
8.5.17	NEW FORMULA.....	21
8.5.18	BITUMINOUS MIXTURES MATERIALS.....	21
8.5.19	SPECIFICATIONS AND GENERAL SPECIFICATIONS (M.T.Q.).....	21
8.5.20	AGGREGATES.....	21
8.5.21	BITUMENS.....	21
8.5.22	BASE LAYER.....	22
8.5.23	SURFACE LAYER.....	22
8.5.24	CHECKING THE QUALITY OF THE MIXTURE, THE THICKNESS AND THE COMPACTION.....	22
8.5.25	ACCEPTANCE AND REJECTION OF A PRIZE.....	22
8.5.26	THICKNESS AND COMPACITY.....	22
8.5.27	REVISED PRICE DURING NON-CONFORMITY.....	23
8.5.28	CONTRACTOR'S Recours.....	24
8.5.29	ELIGIBLE GAPS.....	26
8.5.30	BITUMINOUS CONCRETE FOR CORRECTION.....	26
8.6	LAYING OF BITUMINOUS CONCRETE.....	26
8.7	SPREADING OF BITUMINOUS CONCRETE.....	26
8.8	MANUAL SPREADING.....	27
8.9	ACCEPTANCE OF THE SURFACE TO BE COVERED.....	27
8.10	CLIMATE CONDITIONS AND TRAFFIC.....	27
8.11	HAND TOOLS.....	28
8.12	CLEANING OF HAND TOOLS.....	28



8.13	LONGITUDINAL AND CROSS-SECTIONAL JOINTS.....	28
8.14	JOINTS IN THE BINDER LAYER (BASE).....	28
8.15	SEALS IN THE WEAR layer .....	28
8.16	JOINTS WITH EXISTING PAVement .....	28
9.0	EXISTING SIGNALING.....	29
10.0	MAINTENANCE AND REPAIR BEFORE FINAL ACCEPTANCE OF WORK.....	29
11.0	SODDING.....	29
11.1	GENERAL .....	29
11.2	SITE EXAMINATION .....	29
11.3	Inspection .....	29
11.4	PLANT LAND TESTS .....	29
12.0	LOCAL REPAIRS .....	30
12.1	GENERAL .....	30
12.2	SCOPE OF WORK.....	30
12.3	RECOVERY OF PREMISES .....	30
13.0	SPECIFIC TECHNICAL ENVIRONMENTAL CLAUSES .....	31
13.1	PROTECTION OF THE ENVIRONMENT .....	31
13.2	MANAGEMENT OF EXCAVATION AND BACKFILL MATERIALS .....	33
13.3	DISPOSAL OF EXCAVATION SURPLUSES.....	33
13.4	PRESERVATION OF TREES .....	34

---

## **1.0 NATURE OF THE WORK**

The FRELIGHSBURG EXPERIMENTAL FARM (hereinafter referred to as the "Owner") wishes to carry out the landscaping work on their backyard. The works include:

- The construction survey;
- Signalisation and traffic management;
- Demolition of existing structures such as paving, existing storm sewers and aqueduct pipes, etc.;
- Relocation of the water pumping station and reservoir;
- The excavation and connection of a water main;
- The excavation and installation of storm water pipes including the required catch basins;
- Construction of a drainage trench;
- The excavation, leveling and compaction of the stone foundation for light paving;
- Installation and compaction of paving;
- Pavement sawing;
- Sodding ;
- Protection of existing services; aqueduct, gas and others;
- Environmental measures and management of cut / fill.

The Contractor must provide all the materials, labor and tools required for the installation of all the services described in the specifications, on the tender form and on the plans and profiles and include them in each unit price he will submit.

## **2.0 Sanitary facilities installation**

The Contractor must provide their own sanitary facilities with a sink. The Contractor and his subcontractors will not have access to the building except for the work planned for the installation of the aqueduct and its components

## **3.0 Drinking water cutoff**

The Contractor must notify the owner of any water cut at least 48 hours before said water cut.

During any water cuts, the Contractor must provide an additional sanitary installation for the employees of the Frelighsburg Experimental Farm. This installation must be equipped with a sink.

## **4.0 Generality**

### **4.1 SPECIAL QUOTE**

The general and specific clauses take precedence over the clauses of the general conditions which they supplement. This special quote refers to the standard quote NQ 1809-900 (2018) NQ 1809-300 (2018) and to the general specifications and specifications (CCDG) of the MTQ (2020). These documents are an integral part of the tender documents and the contractors are required to obtain them.

### **4.2 MATERIALS**

Unless otherwise specified, the Contractor must use new materials only.

### **4.3 SITE ORGANIZATION**

Section 10 "Site organization, site premises, traffic maintenance and signaling and environmental protection" of the CCDG (2020) is an integral part of this document and must be fully followed.

### **4.4 CLEANING**

The Contractor must, daily, clean the work site to the satisfaction of the Project Manager. Before the site is closed, the Contractor must collect and dispose of all debris and waste from the work at an authorized site.

## **5.0 EXCAVATIONS AND BACKFILL**

### **5.1 FILLING AROUND THE STRUCTURES**

The Contractor must backfill around structures such as sumps, manholes, valve boxes, etc., using granular material such as MG-20b. The material must be laid on by layers of approximately 600 mm around the structure per layer of 300 mm maximum compacted to 90% of the modified Proctor, except in the portion corresponding to the foundations of streets or the material used as well as the compaction must meet the requirements of standard foundation and paving cuts.

### **5.2 SLOPE STABILITY AND EXCAVATION**

The contractor must take note of the environmental and geotechnical study for the stability of the excavation slope. The contractor must submit the plans signed and sealed by an engineer of his working method and shoring to achieve the slope stability requirements and the safety code for construction work S-2.1, r.4

### **5.3 LOSS OF VOLUME MASS AND SOIL REHABILITATION**

If the natural soil or a layer of a material, already compacted to the required density,

---

undergoes, before the end of the work, a density loss due to the circulation of the equipment, to bad weather, to the action of frost- thaw or for any other reason, the Contractor must redo, at its expense, the compaction to the required density.

#### **5.4 CONTAMINATED MATERIAL**

During excavation work, if the Client or his representative suspect the presence of contaminated material, The Contractor must temporarily suspend the work and must call the laboratory to carry out the tests necessary to determine the contamination present. The Contractor must dispose of the contaminated equipment in a location authorized by the Engineer on site and must cover the equipment with a waterproof membrane while awaiting the specifications of environmental specialists.

### **6.0 City Water**

#### **6.1 GENERAL**

All the prescriptions of the general specification BNQ 1809-300 / 2018 "Construction work – general technical clauses - drinking water and sewer pipe" according to the most recent version, form an integral part of this tender document and must be fully followed with the clarifications in this section.

#### **6.2 PIPES**

The water mains must be either of the type:

PVC-U DR-18, diameter indicated on plans, with seat. All these pipes must comply with the specifications of the BNQ 3624-250 and BNQ 1809-300 / 2018 standards for the installation of the latter.

##### **6.2.1 LOCATOR WIRE**

In order to allow localization of the pipe, the Contractor must install a # 8 CSA TWU (-40 degrees Celsius), 600 V tracer wire along the axis of the pipe over its entire length. This wire must be fixed to each length of pipe, wound at the valves as well as at the base of the fire hydrants up to the flange of the body of the fire hydrant. All the tracer wire joints must be sealed using a self-adhesive rubber membrane of "3M" or equivalent accepted.

##### **6.2.2 CONNECTING**

The Contractor must replace all components of the existing water service connections, at each site indicated on the plans, in cold drawn K-soft copper. All service connections must be 19 to 50 mm in diameter, according to the specifications on the plan.

---

No gaskets are accepted on the copper pipe. The connection to the main pipe must be made with a connection collar on the main pipe in order to install the tap used for the aqueduct connection. This connection collar must be a double band ductile iron saddle with an epoxy coating manufactured by the company ROBAR model 2506DS, with cathodic protection. Any service which could be affected by freezing shall be protected by rigid insulation of the blue styrofoam type HI-60, or the approved equivalent, 50 mm thick and 1200 mm wide, and installed on the material of 'coating.

The Contractor must make the gooseneck of the horizontal connection. The Contractor must provide all connections for vacant lots (T.V.) indicated or not on the plans. On the “as-built” drawings, each service connection must be located in relation to an existing structure. A sign post must be provided and installed at the property line.

Copper service connections must be protected against corrosion with a type Z-12-24 anode.

### **6.2.3 CONNECTION SLEEVE**

The Contractor must install a connection collar on the main pipe in order to install the tap used for the planned water connection. Socket valves are 110 Model H-15008 compression type as manufactured by Mueller Canada or approved equivalent.

The compression seal must have the following technical characteristics:

- When the nut abuts against the shoulder of the fitting, it can be seen visually that it has been tightened;
- The compression nut must have been treated with Teflon to prevent the packings from breaking when tightening. (Lubricants are not allowed because they can dry out over time); and
- A conductive spring must provide metal-to-metal contact to allow electrical conductivity.

### **6.2.4 SERVICE BOX**

Each shut-off valve shall be topped with an extension, fixed-stem type cast iron service box with a cast iron ribbed cover, with a brass pentagonal cap. Unless otherwise specified, water service boxes are Mueller type A 726-SS with A812 steel sensing ring. The box will have the following characteristics:

- Length between 1.8 to 2.4 meters;
- Stainless-steel rod;
- Polarized product;
- Every part must be covered with a bituminous coating (exterior and interior);
- Manufacturer's name must be indicated on the cover and the base;
- Thickness of the steel pipe: min. 100/1000 of an inch nominal grade ASTM A501; and
- 1 "NPT type threads (National Pipe Threads); and
- The pin must be stainless steel.

---

### 6.2.5 CONNECTION VALVES

Only Curb Stop from “Mueller” model H 15209 without a trap are accepted.

The tightness of the Curb Stop must be possible up to 1.2 MPa, (175 PSI).

The compression seal must have the same technical characteristics as those of the intake valves.

### 6.3 WATER SUPPLIES AND ACCESSORIES

All fittings, accessories (elbow, reducer, tee, service connection sleeve, etc.) must be of the same material, of the same class, and come from the same supplier as the main pipes.

### 6.4 WATER RECOVERY

Contrary to article 5.16 of BNQ 1809-300 / 2018, when the ground cover above the water pipes as well as above the private aqueduct connections and fire hydrants is less than 1,800 mm, the Contractor must lay approximately 150 mm above the pipe or the connection, a rigid insulation (blue styrofoam HI-40) 2400 mm wide and 50 mm thick, over the entire distance where the covering is less than 1,800 mm. The Contractor must level the granular material to ensure that the insulation does not crack.

### 6.5 CATHODIC PROTECTION OF THE VALVES AND THE SET OF FIRE TERMINALS

Valves, waterworks service entrances, and the set of fire hydrant sockets as well as all cast iron parts (elbows, tees, etc.) must be protected against corrosion by complying with the following requirements:

#### 6.5.1 CHARACTERISTICS OF ZINC ANODES

All prepackaged zinc anodes are of the Z-24-48 or Z-12-24 type in accordance with the following specifications:

- a) The cast zinc alloy complies with ASTM B-418-73 Type II according to the weights and lengths specified below.

Type of anode	Weight of zinc	Length of zinc
Z-24-48	10,9 kg	1220 mm
Z-12-24	5,4 kg	610 mm

- b) The zinc molding is contained in a cardboard tube having the following dimensions:

---

<u>Anode type</u>	<u>Tube diameter</u>	<u>Tube length</u>
Z-24-48	127 mm	1520 mm
Z-12-24 1	27 mm	760 mm

- c) The zinc molding inside the tube is surrounded by a selected filling, having an electrical resistivity of less than 45 ohm-cm wet, a compacted density of 1.5 g / cm<sup>3</sup> and the following composition:  
Gypse 77 ± 2%      Bentonite 15 ± 1%      Sulfate de sodium 8 ± 1%
- d) All prepackaged zinc anodes are supplied with 3000 mm copper cable # 10/7, with orange TWH insulation.

### 6.5.2 TYPE

The type of anode to be installed on the various equipment must meet the following requirements:

- a) Installation of a prepackaged zinc anode of the Z-12-24 type, on each valve, with a nominal diameter up to 300 mm, as well as on each water service inlet.
- b) Installation of a prepackaged zinc anode of type Z-24-48, on each set of fire hydrant sockets including its valve when the pipe connecting the terminal to the valve is made of cast iron.
- c) When the pipe connecting the fire hydrant to the valve is made of PVC-U, an anode must be installed on each valve according to the requirements described in point a) of this article and for the fire hydrant, it is necessary to install the type of anode Z-24-48 described in point b) of this article.

### 6.5.3 INSTALLATION PROCEDURE

For the installation of the anodes, the Contractor must respect the following procedure:

- a) Place the anodes at the same depth as the pipe, parallel to the pipe and at a minimum distance of 300 mm from the pipe.
- b) Do not handle the anodes by their cable.
- c) Wind and tie the cable from the anode to the fitting to avoid any tension, either on the anode or on the connection to the fitting during backfilling and subsequent soil compaction.
- d) Connect the anodes to the fire hydrant assemblies and to the valves by the aluminothermic welding technique using the products manufactured by Erico Product (# CAB-133-M). Mechanical assembly (with a bolt) will not be allowed.

- 
- e) Make all joints electrically continuous on ductile iron pipes, valves and fire hydrants, either using a key or copper strip specially designed to make the electrical connection.
  - f) Clean and file an area of 50 mm x 50 mm on the surface of the pipe, until the white metal is exposed.
  - g) Strip the end of the anode cable from its insulation, attach it to the metal surface prepared using the thermite welding technique. (N.B. Use Cadweld mold no CAHBA-1G, CA25 XF-19 cartridge and CAB-133-1L socket for the cable).

**Prepare the end of the cable to be soldered as follows:**

- Strip the cable to expose a length of 3.5 cm of copper conductor.
- Make sure the copper conductor is clean and dry.
- Crimp the CAB-133-1L socket on the copper conductor.

**Prepare the welding mold as follows:**

- Scrape the crucible to remove any clinker deposits.
- Insert the tin disk in the bottom of the crucible.
- Pour the contents of a cartridge into the crucible and make sure that there is no ignition powder left from the bottom of the cartridge.

**Solder the cable as follows:**

- Place the soldering mold on the prepared surface and insert the cable underneath.
  - Close the lid and ignite the charge using a gun with a flint.
  - Remove the soldering mold when the solder is a dull red color.
- h) After cooling, blow up the bottom clinker with the side of the file, check the weld by hitting it with a hammer and redo the weld if necessary.
  - i) If the weld is to be redone, a new weld must be made no closer than 15 cm from the original.
  - j) Seal the completed connection against moisture penetration using a good application of "Tapecoat" or "Primer" # 937 sealant.

**6.6 DIVERSION OF AQUEDUC**

The Contractor must carry out a water diversion in order to allow the bypassing of planned or existing obstacles. The Contractor must provide the necessary transition pieces in order to connect to the existing pipe, the material of which is probably different from that of the planned pipe. The Contractor must provide retaining joints on all the parts of the piping necessary for the realization of the water diversion. The retaining joints will be of the UNI-FLANGE 1360 or 1390 series with cathodic protection.



---

## 6.7 CERTIFICATION AND COMPETENCE OF LABOR

The Regulation on the quality of drinking water (art. 44) requires that, for municipal systems with residential customers, the operation and monitoring of the operation of the following facilities be carried out by a recognized competent person (ex OPA certification):

the installation of water catchment (underground or surface); the treatment facility; the distribution installation (including booster and re-chlorination stations); the tanker delivering water intended for human consumption.

In the case of non-municipal systems and municipal systems with an exclusively tourist or institutional clientele, the operation and monitoring of the operation of these same facilities must either be carried out by a recognized competent person, or carried out under the supervision of a recognized person competent.

The Regulation also requires that for municipal systems and for non-municipal systems, certain tasks be performed or supervised immediately by a person recognized as competent. These tasks are:

maintenance or repair of a drinking water distribution pipe; maintenance or repair of equipment attached to a drinking water distribution pipe (fire hydrant, valve, air vent, etc.); the commissioning of a pipe following repair or extension work.

Work performed in connection with the installation and maintenance of a temporary pipe is subject to the same requirements as work carried out on a permanent pipe.

The regulation considers competent all persons holding a diploma, a certificate or a recognized attestation as specified see on the MELCC website <http://www.MELCC.gouv.qc.ca/eau/potable/brochure/>

**The contractor must ensure that the personnel operating or supervising interventions on the drinking water network have all the qualifications required by the regulations.**

## 6.8 RELOCATION OF THE WATER PUMPING STATION

During the relocation of the pumping station, the Contractor must provide all equipment to dismantle the pump as well as all related equipment and transport them to its new location. The contractor must reconnect the pump to the new connection provided.

The photos below show the pump location:



The photos below show the pump to be relocated:



## **7.0 SEWER**

### **7.1 GENERAL**

All the prescriptions of the general specification BNQ 1809-300 / 2018 "Construction work - general technical clauses - drinking water and sewer pipe" according to the most recent version, form an integral part of this tender document and must be fully followed with the clarifications in this section.

### **7.2 SPILL OF WASTEWATER INTO THE ENVIRONMENT**

No discharge of wastewater into the environment is permitted during the performance of the work. The Contractor must take all possible measures to prevent a spill.

### **7.3 DOMESTIC SEWER PIPES**

Domestic sewer pipes must be made of the same material, in accordance with the following specifications:

Domestic sewer lines must be made of unplasticized poly (vinyl chloride) (PVC-U) class DR 35 with seat and coating, in accordance with BNQ 3624-130 standards.

### **7.4 RAIN SEWER PIPES**

All storm sewer pipes are of the diameter indicated on the plans and must be made of the same material, in accordance with the following specifications:

The domestic sewer pipes must be made of high-density polyethylene (HDPE) with seat and coating, in accordance with BNQ 3624-120 standards.

### **7.5 TEX-O-FLEX MEMBRANE**

All manholes (existing and proposed), new sumps (existing and proposed) and valve boxes (existing and proposed) must be surrounded by a "TEX-O-FLEX 40-12" type membrane as manufactured by the company Solmax Texel. The installation method of this membrane must, in all respects, comply with the manufacturer's recommendations, but the following points must be more specifically respected:

The overlap must be at least 300 mm and the membrane must be attached using belts resistant to degradation.

A granular material of the MG-20b type must be placed all around the manhole over a minimum radius of 600 mm, except for the upper part of the manhole which must respect the required street structure cut. Densification of the granular material to 90% of the modified Proctor, per 300 mm layer, must be carried out.

## 7.6 MANHOLE

The Contractor must take note that he must fill in the space between the pipe and the prefabricated sump of all new manholes required in this project. All these manholes are made of reinforced concrete, of the prefabricated type, with rubber lining, ladder, frame and cover. Inlets and outlets are fitted with a suitable monolithic rubber seal. The manholes must comply with the requirements of standard BNQ 1809-300.

For all manholes over 3 meters in height, the Contractor must provide a galvanized steel security grid with a chain and an anchoring eyelet in the manhole head, all supplied by the company Lécuyer or the equivalent approved. In such a case, the frame must be provided with a shoulder to receive this grid. The manhole over 6.0 m must have a galvanized steel safety bearing.

When required, the Contractor must supply and install a chute and a landing in the manholes, as required by the Project Manager.

## 7.7 FRAMES AND LIDS OF MANHOLE, MANHOLE AND KEY MOUTH

The frames and covers required for this project have the following requirements:

- A guiding frame;
- A shoulder at the base of the frame to receive the security grid, when required;
- The frame and the cover of manholes, sumps as well as the mouths of key are of adjustable type of the company Fonderie Laperle or the approved equivalent, of the models described below:

Item	Type
Manhole frame and covers (installation in paving)	Adjustable made of ductile iron, Laperle C 50 M or Mueller Foundry.
Manhole guide frame (installation in paving)	In gray cast iron, adjustable, Fonderie Laperle CG 30.5 or Mueller
Mouth to key	VB-2000 with extension, adjustable and anti-plow.
Sump frame and grid (installation in paving)	In ductile iron, adjustable, Foundry Laperle C 50 P or Mueller. (P-3V grid)
Sump guide frame (installation in paving)	In gray cast iron, adjustable, Fonderie Laperle CG 29.5 or Mueller.
Manhole or sump frame and cover (installation without paving)	In gray cast iron. Laperle C-6S Mueller Foundry. (P-3V grid for sump)

The parts for the frames and buffers must be cast or / and machined so that they fit perfectly into each other. Runways, roughness, burrs and other projections must be removed and any surface must be reasonably even and soft. They must comply with the dimensions indicated on the drawings and sketches provided. Runways, roughness, burrs and other projections must be removed and all surfaces must be reasonably even and smooth.

---

L'ensemble cadre et tampon pour les regards d'égout et les chambres de vannes doit présenter une ouverture libre minimum de 771 mm de diamètre lorsqu'il y a un appui pour une grille de sécurité et de 710 mm dans les autres cas.

The stamps must bear the manufacturer's identification in addition to the lettering requested by the city or the owner where the work is carried out.

### **7.8 PREFABRICATED CATCH BASIN**

The catch basin must be built in compliance with the requirements of the "GENERAL TECHNICAL CLAUSES" and the following criteria:

#### Manholes in the street right-of-way

- a) The diameter of the connection pipes is 200 mm in diameter in PVC-U DR-35 with seat.
- b) The connection to the main pipe must be made with a KOR-N-TEE connector.
- c) The catch basin must have two (2) openings 100 mm in diameter and a drain 5 m long. SOLFOMAX type perforated 320 Kpa with geotextile to drain the street or parking foundation, the openings must be made at the height of the infrastructure. manholes sections must be assembled using butyl trim.
- d) A concrete slab 1200 mm in diameter and 200 mm thick should be used.
- e) The catch basin must be made by Lécuyer type P-4 or the approved equivalent.

### **7.9 HDPE CATCH BASIN**

The catch basins must be built in compliance with the requirements of the "GENERAL TECHNICAL CLAUSES" and the following criteria:

- a) When specified on the plan, the contractor must provide for the supply and installation of HDPE catch basins.
- b) The pipe used to manufacture the manhole will be certified to standard NQ 3624-120 as manufactured by Soléno.
- c) The catch basin will be made of a polyethylene resin conforming to the classification by properties PE 334420C, as defined according to standard ASTM D3350.
- d) The diameter of the connection pipes is 200 mm in diameter in PVC-U DR-35 with seat.
- e) The catch basin must have two (2) openings 100 mm in diameter and a drain 5 m long. SOLFOMAX type perforated 320 Kpa with geotextile to drain the street or parking foundation, the openings must be made at the height of the infrastructure.
- f) The catch basin sections must be assembled according to the manufacturer's requirements.
- g) The frames, grids or covers will be made of cast iron of the S series.
- h) The catch basins under the floor must be triple-walled with a smooth exterior as produced by Soleno.

### **7.10 PROTECTION OF THE WATERMAIN**

The Contractor must install rigid insulation to protect the water pipe when the catch

---

basin or manholes are installed at a distance of less than 1000 mm from the aqueduct pipe. The costs of rigid insulation are payable on the slip.

## **8.0 FOUNDATION AND PAVING**

### **8.1 GENERAL CONDITION**

The requirements contained in these clauses apply to all foundation and paving work. The Contractor is required to comply with them as well as with all those of the specific technical clauses and other documents which form an integral part of the contract.

### **8.2 SCOPE OF WORK**

Foundation and paving work include the labor, materials, machinery and tools necessary for the execution of foundation and paving work. They also include the transport and supply of any necessary material as well as the cleaning of the premises, the removal of unusable materials, the installation of crushed stone, the preparation of the surface and the seal coating, as well as all other work necessary for the proper execution of the work in accordance with the plans and specifications.

### **8.3 AGGREGATES AND ASPHALT**

The granular materials and the bituminous concrete used for the pavement structure must meet the requirements of the CCDG of the MTQ, the most recent edition for this type of use. The aggregates will be new.

### **8.4 FOUNDATION**

#### **8.4.1 PUTTING IN PLACE AND COMPACTION OF THE FOUNDATION**

The materials will be leveled to obtain the profile shown on the plans.

The Contractor must ensure that the materials do not undergo segregation and, if necessary, must scarify and moisten them in order to meet the requirements of compaction.

The foundation will be compacted with the appropriate equipment so as to obtain a compactness of at least 95% of the Modified Proctor.

The finished surface must be uniform, free from depression and conform to the determined profile and crown. All places unreachable to the roller must be mechanically pounded in order to obtain a compaction equal to that of the rest of the foundation.

The finished surface must not have any depression greater than 10 mm within 2 m of the prescribed profile.

---

The Contractor must take into account the weather conditions so that no foundations are left under bad weather. According to the above, unstable or saturated surfaces must be repaired at the Contractor's expense.

#### **8.4.2 CONSTITUENT LAYER**

The constituent layers of the street foundations (sub-foundation or geotextile, lower foundation and upper foundation) are as shown on the plans.

#### **8.4.3 FOUNDATION TRANSITION**

When connecting to the existing pavement, the Contractor must make a transition in materials as illustrated in the standard drawing DN-II-1-021 from the MTQ.

#### **8.4.4 MAINTENANCE AND DECONTAMINATION**

The Contractor must keep the street suitable for vehicles, according to the specifications of the Contracting Authority.

The Contractor must also prepare and shape the upper foundation for the reception of the paving layer.

#### **8.4.5 CRUSHED STONE**

The crushed stone must meet the criteria of BNQ 2560-114 in its most recent update and with the related sections relating to the registered standard.

#### **8.4.6 ACCEPTANCE OF THE LOT**

The acceptance check is carried out after the complete implementation of the layer or batch. Sampling and testing has to be carried out by the supervisor or his representatives.

The judgment on the conformity of the granulometry of the foundation materials is based on the batch evaluation. Each lot represents an area of approximately 7,500 m<sup>2</sup> unless otherwise indicated in the plans and specifications (e.g. three (3) samples per street); it always consists of three (3) samples located randomly and representing three (3) equal sections. At the end of a contract, any area less than 1500 m<sup>2</sup> is incorporated into the previous lot. The lot limits are determined by the supervisor before the start of work and this information is communicated to the Contractor.

A non complying lot is when the average of the three (3) particle size results fully meets the requirements stipulated for the 5 mm and 0.080 mm sieves and the measured compactness meets the requirements.

#### **8.4.7 REJECTION OF A LOT**

---

A batch is rejected when the difference between the average of the three (3) grain size results and the values set by the M.T.Q. for the percentage passing through the sieve of the aggregates exceeding at least one of the critical deviations (EC), defined below:

Ec (For spec. below the 5 mm sieve)	:	-5%
Ec (For spec. over the 5 mm sieve)	:	+5%
Ec (For spec. over the 0.080 mm sieve)	:	+1%

In this case, the Contractor removes and replaces, at his expense, the aggregates included in the rejected lot.

#### 8.4.8 REVISED PRICE DURING NON-CONFORMITY

The unit price, per square meter, includes the manufacturing, supply of all materials, drilling, blasting, crushing, storage, correction of particle size, loading, weighing, processing, compaction and any incidental expenses. Transport is also included in full in the unit price, unless it is the subject of specific articles on the slip.

If the average of the three (3) particle size results of a batch or six (6) results exceeds the requirements stipulated for 5 mm and 0.080 mm sieves while being less than or equal to critical deviations defined for these sieves, the Contractor removes and replaces, at his own expense, the crushed aggregates included in this lot or accepts that the unit price be revised according to the following formula:

$$PR=(1-(F_{c.80}+F_{c.5})) \times PU$$

PR :	revised unit price
F <sub>c.80</sub> :	correction factor for the characteristic "passing 0.080 mm"
F <sub>c.5</sub> :	correction factor for the characteristic "passing 5 mm"
PU :	unit price on the slip
X :	batch average (% passing)

$$F_{c.80}=40(x-7)/100$$

According to the batch average for the percentage passing the 5 mm is greater than 60 or less than 35, the correction factor F<sub>c.5</sub> is calculated according to one of the following formulas: (the numbers 60 and 35 may change depending on the size of the aggregates)

$$F_{c.5}=8(x-60)/100$$
$$F_{c.5}=8(35-x)/100$$

The retention for a non-conforming crushed aggregate is obtained by multiplying (PU + PR) by the targeted quantities.

#### 8.4.9 CONTRACTOR'S RECOURSE

When a batch does not comply with the requirements for acceptance of a batch and the Contractor wants to exercise his right of recourse, he must use the control samples which he has already had taken at the same time as those of the materials control



---

laboratory. If such samples have not been taken, it must hire an independent laboratory to randomly take new samples and seal them. The new tests must be carried out by a laboratory member in good standing of the A.C.L.E. The taking of new samples as well as the performance of particle size tests must be carried out during working hours and days. The cost of additional withdrawals is at the expense of the Contractor.

The determination of the location of the samples, the samples and the tests must be carried out in the presence of a representative of the laboratory mandated by the client. Any comments regarding methods deemed to be incorrect must be notified immediately, and any diverging opinion must be notified in writing to the Promoter by the Contractor within seven (7) working days of the date of receipt of the original results from the laboratory, otherwise the Contractor waives his right of recourse.

The total number of withdrawals from a batch is six (6). They are used for the final calculation of the batch average. Compliance is again assessed by the supervisor and the revised price is established, if applicable.

The cost of the particle size tests is at the expense of the Contractor when the average value calculated from the new batch results does not fully meet the requirements. If, on the contrary, the new results are consistent, the costs of the particle size tests are then shared equally with the Promoter.

The Contractor who installs the asphalt or any other material before receiving the particle size results from the foundation waives his right of recourse, unless the samples were taken before recovery, according to the procedure defined in this article.

The Contractor must present their new results within seven (7) days after taking the samples, otherwise, the City considers that the Contractor waives its right of recourse. The latter must, however, reimburse the Contracting Authority for the costs which he has incurred.

#### **8.4.10 CHANGES OF ALIGNMENTS OR PROFILES**

The Engineer reserves the right to make changes to the alignments or on the profiles shown on the plans. When the Contractor is notified of such a change, he must comply with it without delaying the work.

#### **8.4.11 INFRASTRUCTURE STABILITY**

The Tenderer must tender with the express agreement that he must take all the necessary precautions in the preparation of the infrastructure so that his paving is permanently supported and he will not be relieved of the responsibility imposed on him by this clause because " soil of lower quality or that trenches and tunnels would have been made prior to the date of receipt of tenders at or near the paving to be built.

### **8.5 PAVING**

#### **8.5.1 TERMS AND CONDITIONS**

---

The requirements contained in these clauses apply to any foundation correction and paving work. The C

### **8.5.2 GENERAL SPECIFICATIONS AND SPECIFICATIONS (CCDG)**

The various types of asphalt mix installed must meet the requirements of section 14 of the CCDG. 2020. Only the articles mentioned below take precedence over the CCDG of the MTQ.

### **8.5.3 ADJUSTING PUBLIC SERVICE PARTS**

Before proceeding with the paving works, according to what is written on the slip, the Contractor must adjust or replace the services such as manhole frames, catch basin or valve box, in order to meet the profiles shown on plans.

Unless otherwise indicated, the adjustment must be made with materials of the same shape, size and quality as those which constitute the existing structures. No degradable brick or part can be used for this work.

In the absence of adjustable frames and covers, the services must be adjusted to 12 mm lower than the final level of the paving.

The Contractor must provide that adjustments can be made up to a height of 50 mm higher than the existing level, but that damaged parts may have to be replaced up to a depth of 350 mm. These parts will be paid individually. In addition, final adjustments must be made with concrete rings of 100 mm for manholes and 150 mm for sumps. For any lesser thickness adjustment and in the absence of an adjustable structure, rubber rings, as specified in BNQ 1809-300 / 2018, must be used.

Slope adjustments must be made using two (2) variable rings placed in the appropriate axis.

Mortar and shims will not be accepted. If more than one ring is used, the Contractor will join them together using four (4) galvanized screws.

For sanitary manholes, tight seals (butyl) must be installed between each element or section.

Before proceeding with the laying of the paving, the Contractor must thoroughly clean the surface and brush with a bonding binder the surfaces in contact with the paving, ie the borders, manholes, etc.

The unit price on the schedule includes the excavation around the services, the stone filling, the supply of all the materials, the transport, their implementation, the painting and any incidental expenditure.

### **8.5.4 REPLACEMENT OF MANHOLE SECTION**

---

When a manhole or catch basin section needs to be replaced, the Contractor must remove the manhole and catch basin head to replace the said section.

The replacement must be made with materials of the same shape, size and quality as those which constitute the existing structures. Concrete sections thus replaced must be manufactured by Lécuyer or equivalent approved upon submission.

The Contractor shall provide for the removal and disposal of the section, the excavation, the backfilling, the supply of all materials, transportation, implementation and all other incidental expenses.

If the removed section is judged to be in good condition by the Engineer, it must be delivered to the place that the Contracting Authority will indicate to the Contractor.

### **8.5.5 VALVE BOX REPLACEMENT**

When required and requested by the Engineer, the Contractor must replace the top section of the valve box with a new valve box. The replacement must be made with materials of the same shape, size and quality as those which constitute the existing structures but must be adjustable (variable height by sliding). The replaced sections must be manufactured by Mueller or Fonderie Laperle.

The Contractor shall provide for the removal and disposal of the damaged section, excavation, backfilling, supply of all materials, transportation, implementation and other incidental expenses.

If the removed section is judged to be in good condition by the Engineer, it must be delivered to the place that the Contracting Authority will indicate to the Contractor.

### **8.5.6 REPLACEMENT OF FRAMEWORK**

When indicated in the plans and specifications or at the request of the Engineer, the Contractor must replace the manhole frames which are damaged and replace them with an adjustable structure as manufactured by Mueller or Fonderie Laperle.

The manhole frame will be made of ductile iron and must meet the requirements of standard BNQ 1809-300-2004.

If the removed section is judged to be in good condition by the Engineer, it must be delivered to the place that the Contracting Authority will indicate to the Contractor.

### **8.5.7 REPLACEMENT OF THE CATCH BASIN'S HEAD**

When indicated in the plans and specifications or at the request of the Engineer, the Contractor must replace the catch basin's heads which are damaged by an adjustable structure as manufactured by Mueller or Fonderie Laperle.

---

The replacement must be made with materials of the same shape, size and quality as those which constitute the existing structures but the structure must be able to be adjusted by sliding. The replaced concrete sections must be manufactured by Lécuyer or an approved equivalent.

If the removed section is judged to be in good condition by the Engineer, it must be delivered to the place that the Contracting Authority will indicate to the Contractor.

### **8.5.8 ELEVATIONS AND LOCATIONS**

All construction must be done according to the levels and alignments planned and accepted by the Engineer. All work not complying must be demolished and replaced by the Contractor, at his expense and expense, and to the satisfaction of the client.

### **8.5.9 CHANGE TO ALIGNMENTS OR PROFILES**

The Engineer reserves the right to make changes to the alignments or to the profile on the plans. When the Contractor is notified of such a change, he must comply with it without delaying the work.

### **8.5.10 CONNECTION WITH EXISTING PAVING**

In places where it is necessary to connect to existing paving or where a certain part must be repaired or widened, unless otherwise indicated, the costs of these works are included in the contract and include the following works:

- sawing the existing paving as well as removing and transporting it off site;
- scarification of the existing stone to a minimum depth of 100 mm from the existing surface to allow uniform compaction;
- compaction of the foundation to 95% of the modified Proctor;
- supply and installation of priming bitumen;
- supply, placement and compaction of bituminous concrete; and
- all other work necessary for the implementation of these works.

The Contractor is responsible for the sawn edges of paving and any crumbling, breakage or other, must be resawed in a straight line. Work in this excess area to be repaired is at the Contractor's expense.

### **8.5.11 BITUMINOUS COATING**

The Contractor must use the type of coating specified in this document. If during the performance of the contract, the Engineer deems it necessary to use a bituminous coating other than the type specified in the tender, the Contractor will be paid in addition to or less than the price entered in the schedule for the bituminous coating.

---

When a binder layer is used, it must be covered by the wearing surface within twenty-four (24) hours following the installation of the binder layer unless otherwise instructed by the Engineer.

The bituminous concrete used must have the composition and have the other characteristics specified in the estimate. It is the same for all the materials used in its manufacture.

### **8.5.12 MIXTURE FORMULA**

These mixtures are prepared in a central coating station. They consist of coarse aggregates

and fine aggregates or only fine aggregates, uniformly coated with a bituminous binder heated to the specified temperatures.

### **8.5.13 ACCEPTANCE OF THE CONSTITUENTS OF BITUMINOUS MIXTURES**

For verification and acceptance, the Contractor must submit to the Contracting Authority's

laboratory, one (1) week before the start of work, representative samples as a basis of comparison to judge the uniformity of production.

### **8.5.14 ACCEPTANCE OF BITUMINOUS MIXTURE FORMULAS**

For verification and acceptance, the Contractor must submit to the Contracting Authority, at least one (1) week before the start of work, the bituminous mix formulas which will be used.

The Contractor must provide the following information for each type of mixture:

- a) the provenance, particle size, intrinsic and manufacturing tests as well as the percentage or proportion by weight or by volume of the cold aggregates and the granularity of the combined;
- b) the percentage of absorption of the combined cold aggregate;
- c) the granularity of the bituminous mixture;
- d) the proposed bitumen content, the compatibility of the mixture as well as the average thickness of the film of effective bitumen at the proposed bitumen content; and
- e) the curves of the physical characteristics of the mixture at five (5) points for each of the following features:

- stability
- the creep index
- unit mass
- the percentage of vacuum in the mixture
- the percentage of void between the aggregates

An initial verification is made by a test laboratory to ensure that the data of the mixing formula conform to the standards indicated.

---

Subsequently, the laboratory verifies, by means of laboratory tests, the data supplied by the Contractor. This verification is accompanied by the analysis of the first four (4) samples of the mixture produced.

Following this verification, the Contracting Authority advises the Contractor of its decision.

#### **8.5.15 SITE APPROVAL**

From the start of the Contractor's operations, the Engineer verifies, by analyzing a first batch of samples, whether the admissible deviations in the mixture from the formula submitted are in conformity.

The Engineer also checks the compaction, texture and appearance of the coating. If necessary, the necessary corrections are made to the proposed formula.

#### **8.5.16 FINAL APPROVAL**

The final mixing formula approval is made after the overall analysis of the test results, at the end of the asphalt work or at the time of the cessation of the production of this mixing formula.

#### **8.5.17 NEW FORMULA**

Any new formula cannot be used until it has been checked by the laboratory. When a source of aggregate is changed, a new formula is required.

#### **8.5.18 BITUMINOUS MIXTURES MATERIALS**

#### **8.5.19 SPECIFICATIONS AND GENERAL SPECIFICATIONS (M.T.Q.)**

The various types of asphalt mix installed must meet the requirements of the CCDG 2020 and the most recent addenda. Only the articles mentioned below take precedence over the CCDG of the MTQ.

#### **8.5.20 AGGREGATES**

The aggregates inside the proposed mixing formulas must meet the following requirements:

Large aggregate: category 3c of standard 2101 (individual result)

Fine aggregate: category 2 of standard 2101 (individual result)

#### **8.5.21 BITUMENS**

The bitumen must comply with CCDG 2020 and meet the specifications of MTQ standard 4101.

### **8.5.22 BASE LAYER**

The base layer must meet the requirements listed on the plans and must be 100% fragmented. In addition, the base coat must be laid according to the dates on the slip.

### **8.5.23 SURFACE LAYER**

The surface layer must comply with the requirements listed on the plans and must be 100% fragmented. In addition, the surface layer must be laid according to the dates indicated on the slip.

At all times, a bonding binder must be applied uniformly to the surface (l / m<sup>2</sup>) according to the type of surface as described at the CCDG before the installation of the surface layer.

At all times, the Contracting Authority reserves the right to sample bitumen at the factory. The results obtained will prevail over those of the Contractor. On each production day, the Contractor must provide a certificate of bitumen compliance.

### **8.5.24 CHECKING THE QUALITY OF THE MIXTURE, THE THICKNESS AND THE COMPACTION**

The quality of the mixture put in place is verified by random sampling with 300 metric tonnes of asphalt for a total of 1,500 metric tonnes per batch, or five (5) samples.

The verification of the compactness and thickness is carried out by the sampling of carrots, at a random rate, on the area covered by 1000 m<sup>2</sup> of bituminous mix.

### **8.5.25 ACCEPTANCE AND REJECTION OF A PRIZE**

A batch is accepted when the difference between the average of the batch results and the mixing formula is less than or equal to the tolerable difference for each of the characteristics passing 0.080 mm, bitumen and compactness. The unit price is however revised.

A batch is rejected when the difference between the average of the batch results and the mixing formula is greater than the critical difference for one of the characteristics passing 0.080 mm, bitumen or compactness. In this case, the Contractor removes and replaces, at his expense, the paving included in the rejected lot.

### **8.5.26 THICKNESS AND COMPACTITY**

The thickness and degree of compaction must be determined on each sample. The average thickness and the average of the degrees of compaction must be calculated per street.

For the calculation of the average thickness of the bituminous concrete covering, the samples having more than 10 mm than the required thickness are considered to have only 10 mm more than the required thickness.

When the average thickness of the bituminous concrete coating is greater than the specified thickness or if the average thickness is less than the required thickness of 5 mm or less, the bituminous coating is accepted and paid at the unit price of the contract.

When the average thickness of the bituminous coating is less than more than 15 mm from the specified thickness, the batch is refused and work must be resumed on the extent of the batch.

When the average thickness of the bituminous concrete covering is less than the thickness by more than 5 mm, but less than 15 mm, the unit price is revised.

When the compactness of a batch is less than 93.0% minus the critical deviation, i.e. below 89.0%, the batch is refused. The work must be resumed on the extent of this lot including all the required work, even if the non-conformity in base coat is disputed.

The unit price of the lot is adjusted using the formula presented when the average compactness value is less than 93.0% minus the tolerable difference.

### 8.5.27 REVISED PRICE DURING NON-CONFORMITY

Tolerable deviations (Et) from the formula for the main characteristics as a function of the types of mix and the number (N) of samples constituting the batch						
ENROBÉ						
Main characteristic	Type of asphalt	E <sub>t</sub> pour N=5	E <sub>t</sub> pour N=4	E <sub>t</sub> pour N=3	E <sub>t</sub> pour N=2	E <sub>t</sub>
Passing 5 mm	EB-20	4,8	5,4	6,2	7,6	10,0
	EB-14	3,7	4,1	4,8	5,8	8,0
	EB-10S, EB-10C et CH-10	3,3	3,7	4,3	5,2	7,0
	all coated	0,8	0,9	1,0	1,2	1,7
Particle size total	EB-20 et EB-14	19	21	24	30	40
	EB-10S, EB-10C et CH-10	14	16	18	22	30
Bitumen	all coated	0,24	0,27	0,31	0,38	0,50
COMPACITÉ DU REVÊTEMENT						
Compactness of the coating	Type of asphalt	N=6	N=4	N=3	N=2	E <sub>c</sub>
	EB-20	0,8	1,1	1,2	1,4	4,0
	EB-14, EB-10S	1,0	1,3	1,4	1,6	4,0
	EB-10C et CH-10					

Note 1: For compactness, tolerable and critical deviations are applied to the minimum requirement of 93%.

Note 2: Tolerable and critical deviations apply to the average value of the lot compared to the mixture formula.

Note 3: The value of the deviations indicated is expressed as a percentage.

#### Calculation of the revised unit price of a lot:



---

The calculation of the revised price for the mixture will be calculated separately for the mixture as well as for the compactness and thickness. However, the overall unit price will take account of the two revised prices and will have to be calculated on the part of the work or the revised unit price will apply.

$$PR_f = PU (1-F_{80} + F_b ) \times (E_m/E_s) \times (1-F_c)$$

Thickness and compactness:

$$PR_{rec} = PU (E_m/E_s) \times (1-F_c)$$

Mixed :

$$PR_m = PU \times (1-F_{80} + F_b )$$

If the sum ( $F_{80} + F_b$ ) or  $F_c$  is greater than 1, this value is reduced to 1.

$PR_f$  = final revised price for mix, thickness and compactness

$PR_m$  = revised price for mixture

$PR_{rec}$  = revised price for thickness and compactness

$PU$  : the unit price includes: the basic price of the mixture, the cost of bitumen and the cost of operations (installation, transport of bitumen and mixture).

$F_{80}$  : correction factor for the characteristic "passing 0.080 mm".

$F_b$  : correction factor for the "bitumen" characteristic.

$F_c$  : correction factor for the characteristic "compactness".

The correction factor  $F_c$  is calculated according to the following formula:

$$0,125 (93-D)$$

$D$  : average compactness of the batch

$93$  : minimum compactness required

The correction factors  $F_{80}$  and  $F_b$  are calculated according to the following formula:

$$\frac{0,50 \times E_f/m - E_t}{E_c - E_t}$$

$E_f/m$  : difference in value between the formula and the lot average

$E_t$  : tolerable deviation

$E_c$  : critical deviation

$E_m$  : average batch thickness

$E_s$  : Thickness specified in tender documents

### 8.5.28 CONTRACTOR'S RECOURS

When the Contractor is assigned a revision of the unit price for the bituminous mixture, he is entitled to exercise a right of recourse in order to reassess the penalizable

---

characteristic or characteristics are: passing 0.080 mm, percentage of bitumen, compactness and thickness.

Re-evaluation of the characteristics of the mixture (passing 0.080 mm and percentage of bitumen):

The Contractor may request the Engineer the right to exercise his right of appeal within fifteen (15) days of receipt by the Contractor of the results of the analyzes.

These analyzes are carried out on the so-called "witness" boxes taken by the laboratory mandated by the City during the construction site.

The resumption of analyzes on one or more samples is carried out by a laboratory appointed by the Contractor provided that the latter is not the one who carried out the control tests for the coating plant during the production of the mixture deemed deficient.

The cost of the recovery is the responsibility of the Contractor unless the average value calculated from previous results and those of the right of appeal indicates that the lot is in conformity.

The Owner reserves the right to send a representative of his authorized laboratory when exercising the Contractor's right of recourse. Any comment on an operation deemed defective must be notified immediately and any case of discrepancy is brought to the attention of the owner.

Re-evaluation of thickness and compactness characteristics

The Contractor may have additional samples taken, at his expense, in accordance with the following conditions:

The Contractor may take a carrot for each sample taken by the Engineer but within a radius of three (3) meters from it, in the presence of a representative of the Contracting Authority. The thickness and compaction measurements must then be made by a testing laboratory recognized and approved by the Contracting Authority.

The methods of these measurements used in the case of the Contractor's samples must be the same as those used by the Client.

The laboratories which will carry out the tests for the Contractor must communicate the results of these tests to the Contracting Authority as well as a report indicating the exact date and location from which each of the samples analyzed was taken.

The result of the cores taken by the Contractor must be combined with the result of the corresponding cores taken by the Client for the calculation of the average thickness and compactness, for each of the lots.

The holes dug in the paving must be filled immediately after sampling by the Contractor, at his expense, with a material of the same kind as that which was used to make the paving.

The laboratories which will carry out the tests for the Contractor must communicate the results of these tests to the contracting authority as well as a report indicating the exact date and location where each of the samples analyzed was taken.

#### **8.5.29 ELIGIBLE GAPS**

The admissible deviations in the mixture compared to the established formula must meet the requirements of standard 4201 of volume VII of the MTQ.

#### **8.5.30 BITUMINOUS CONCRETE FOR CORRECTION**

The mixture for this bituminous concrete must be EB-10C PG 58-28. This bituminous concrete must be placed over the existing bituminous surface in places where it is lower than the established levels.

#### **8.6 LAYING OF BITUMINOUS CONCRETE**

Installation of bituminous concrete, transport, etc. must be carried out in accordance with the CCDG 2020.

#### **8.7 SPREADING OF BITUMINOUS CONCRETE**

If the layer of bituminous concrete cracks abnormally during spreading or during rolling, the work must be suspended and the necessary corrections made.

It is forbidden to spread by hand or sprinkle the bituminous concrete at the back of the spreader to correct these anomalies.

Avoid vibrating, trampling or treading the bituminous mixture before rolling, and all the parts thus treated must be raked right through, and you must add a little mixture to start the compaction again using of a roll.

The spreader should be adjusted to spread a uniform layer, the thickness of which should be as close as possible to that specified.

##### Rollers

The rollers must make it possible to obtain compactness and conforming surface characteristics. The following types are accepted:

a) Rollers with steel cylinder

The rollers with steel cylinders can be of the following three (3) types:

- three (3) wheel rollers weighing from 9,000 kg to 10,900 kg;
- two (2) cylinder tandems weighing from 7,250 kg to 10,900 kg; or
- three (3) cylinder tandems weighing from 10,900 kg to 16,300 kg.

b) Tire rollers

---

These rollers have scrapers and pads to keep the cylinders clean and moist and prevent the mixture from sticking to them. They are perfectly cylindrical, free of flat parts, sunken or having relief, likely to mark the coating. They must exert a sufficient longitudinal linear pressure.

### **8.8 MANUAL SPREADING**

In places inaccessible to the mechanical finisher, the mixture is spread manually. The mixture is evenly distributed and spread out in a loose layer of uniform density using rakes or hoes, taking care to avoid segregation. Before rolling, the Contractor must check the surface with a ruler and correct any unevenness.

### **8.9 ACCEPTANCE OF THE SURFACE TO BE COVERED**

Before the engineer accepts the laying of bituminous concrete layers, the surface to be covered must meet the following standards:

- a) The surface to be covered must have a slope and a layout in accordance with the plans. It must be dry, well compacted and free from foreign or non-adherent materials.
- b) When the base is rough and / or irregular, the Contractor must use a correction layer placed with a motor grader or spreader and compacted at least twelve (12) hours before he lays the layers subsequent.
- c) When a correction layer is not necessary, the depressions and irregularities are corrected to the satisfaction of the Engineer. The Contractor must remove excessively rich or defective parts, beads and surpluses accumulated in cracks, joints or elsewhere.

### **8.10 CLIMATE CONDITIONS AND TRAFFIC**

The preparation and installation of bituminous mixtures must be done under favorable climatic conditions. It is not allowed to operate when the humidity of the aggregates affects the temperature of the mixture and the rate of operations or when the surface to be covered is soggy, covered with puddles of water or mud.

The temperature of the surface to be covered must be greater than 5 ° C and the ambient temperature must allow coatings or treatments to comply with the requirements.

During operations and during the hardening or drying of a plaster or binder and when traffic must be maintained on the treated surface, the speed of the vehicles must not exceed  
25 km / h until hardening or adequate drying of the plaster.

The Contractor must, at his expense, provide and maintain barricades, signals and employ the guards necessary to divert traffic and prevent any deterioration of the paving bed and prevent the formation of ruts during the work.

The owner reserves the right to stop the work if the atmospheric conditions do not seem suitable to him.

If traffic is allowed on a given section before the installation of the upper layer, the surface of the lower layer must be thoroughly cleaned before the installation of the one which is to cover it.

### **8.11 HAND TOOLS**

The pestles used to compact the mixture in places inaccessible to the rollers must weigh at least 10 kg / cm<sup>2</sup>. The pestles can be replaced by mechanical compactors, approved by the Engineer. The Contractor must have at his disposal a rule of three (3) meters provided with a level to check the uniformity of the coating.

### **8.12 CLEANING OF HAND TOOLS**

When hand tools are cleaned in a fire, the Contractor must take care not to bring them to temperatures high enough to burn the mixture. When hand tools are cleaned with oil, the oil container is placed in a location such that the mixture cannot be damaged. The cleaning operations are done in one place.

### **8.13 LONGITUDINAL AND CROSS-SECTIONAL JOINTS**

The longitudinal joints must be parallel to the lines of the layout. The laying of the mixture at the end of the day is arranged so as not to leave a longitudinal joint to be completed the next day. Between the new and the old roadways or between the works of two (2) consecutive days, the joints are made in order to ensure a perfect, continuous and waterproof connection. Any transverse or longitudinal cold joint whose temperature is below 40 ° C must be painted with a uniform layer of emulsion or liquid bitumen. The Contractor must do everything in his power to prevent cold seals from being made.

### **8.14 JOINTS IN THE BINDER LAYER (BASE)**

When the laying of the binder layer is suspended, the Contractor must, before resuming the laying work, bring the end of the layered layer to the full specified thickness, then place the hot mixture in close contact with the exposed edge of this layer so that after rolling, there is a perfectly united joint.

### **8.15 SEALS IN THE WEAR LAYER**

When the installation of the wear surface is interrupted for a considerable time, the applied surface must be completely cylindrical and its edge immediately cut, so as to have a vertical joint with a rough surface over the entire thickness of the surface layer.

### **8.16 JOINTS WITH EXISTING PAVEMENT**

The edge of the paving already laid must be cut (saw cut) over its entire thickness and brushed with a thin and uniform layer of liquid asphalt to expose a surface against which the hot mixture must be laid and raked to the thickness desired. Pestles and hot irons should be used with caution so as to heat the old pavement enough to secure a bond. At the point of connection between a new paving and an old paving, the Contractor must

---

take care to make an adequate joint and, to do this, must cut the old paving of a depth of 5 cm and a length of 1 m on the whole width of this old paving.

The notch thus made must be coated with a special binder and new paving.

## **9.0 EXISTING SIGNALING**

The Contractor is responsible for removing, moving and reinstalling existing signage. The cost of this work is included in its unit price for signage.

## **10.0 MAINTENANCE AND REPAIR BEFORE FINAL ACCEPTANCE OF WORK**

During the warranty period, the Contractor will carry out all repairs deemed necessary by the Engineer. If he does not comply with the requisitions of the Engineer on this subject, the latter, after having notified the Contractor in writing to perform the said work within the following four (4) days, will take the necessary measures to have these works carried out. repairs at the Contractor's expense and expense.

## **11.0 SODDING**

### **11.1 GENERAL**

All the prescriptions of the general specification NQ 0605-100 "Landscaping using plants" form an integral part of this tender document and must be fully followed with the details of this section.

The maintenance of grassed surfaces must be done during 15 calendar days (watering, cutting, etc.) from the date of the end of installation date.

### **11.2 SITE EXAMINATION**

Notify the Client in writing of any situation he notices on the site, before or during the work, which could affect the work in this section. Stop work until the situation has been inspected and corrected. The beginning or the continuation of the works implies that the Contractor cannot make any claim which may result from any situation which he has thus accepted.

Notify the Contracting Authority in writing when the work is completed.

### **11.3 INSPECTION**

The inspection for acceptance of this work takes place within forty (40) days after the notice has been sent.

### **11.4 PLANT LAND TESTS**

---

The topsoil supplied by the Contractor must be analyzed at the Contractor's expense by a specialized laboratory and accepted by the Contracting Authority before the start of the work. The laboratory must provide the results of the analyzes, in writing, whether or not compliant.

The topsoil must be composed of a homogeneous mixture corresponding to silty sand and meeting the physical and chemical requirements of standard NQ 0605-100.

## **12.0 LOCAL REPAIRS**

### **12.1 GENERAL**

All the prescriptions of the general specification NQ 0605-100 "Landscaping using plants", of chapter 13 "Asphalt pavement" of the CCDG and BNQ 1809-500 "Sidewalks and curbs" are an integral part of this document and must be followed in full with the details in this section.

### **12.2 SCOPE OF WORK**

All places (grass, hedge, tree, shrub, curb, sidewalk, post, paving, etc.) damaged by the Contractor during the work must be repaired by the latter, to the satisfaction of the engineer.

After repairing the curbs and sidewalks, the Contractor must put in place, behind them, class "B" equipment accepted by the Contracting Authority if no lawn exists. For all sections of lawn that will have been affected, the Contractor must install sod and 150 mm thick topsoil to restore the affected areas to their original state. During this filling at the back of the curbs, the Contractor must adjust the water service box.

After all the granular foundation, paving and sidewalk work, the Contractor must ensure that the catch basin, manholes and sewers are properly cleaned (sanitary, rain, combined). The Contractor must include these costs within the articles of the bid schedule.

### **12.3 RECOVERY OF PREMISES**

The contractor must provide for the restoration of the premises affected by the work without limitation; he must provide for the following repairs;

#### Turf

1. The repair works are as indicated on the plans, ie the restoration of the surfaces currently in turf;
2. Repair work on private land must be carried out to the most distant place damaged by the work or to the place indicated by the Project Manager when land reprofile work is necessary following the change of geometry;
3. 150 mm of topsoil must be provided and installed before laying the sod.

---

### Hydraulic seeding

- The seeding work must be carried out in the places where the ditch was repaired. The surface of agricultural land must be covered with 150 mm of topsoil (ideally the same pickling soil as before the work). All other surfaces that are not sodded must be seeded to the most distant place, damaged by the work or to the place indicated by the engineer when ground reprofile work is necessary following the change of geometry;
- 150 mm of topsoil must be supplied and installed before the hydraulic seeding operation; and
- Repair work on land other than that specified in a) must be carried out on all the part damaged by the work or because of the work.

### Hedges, shrubs, trees

- Adequate removal and storage;
- Digging where hedges, shrubs and trees are to be replaced;
- Adding topsoil;
- The required fertilizer;
- Replacement of broken plants.

### Borders, sidewalks

- The removal and off-site disposal of the part damaged or removed during the work;
- Reconstruction of new curbs and sidewalks including expansion joints.

### Crushed stone entrance and paving

- Removal and off-site disposal of existing paving;
- Reconstruction of the granular foundation according to the types and thicknesses specified;
- The laying of a layer of paving, according to the thickness specified on the plans

### Fence, barrier, etc.

- Dismantling of fence barriers, bollards, jersey
- Storage and protection during works and;
- Replacement at the end of the work

## **13.0 SPECIFIC TECHNICAL ENVIRONMENTAL CLAUSES**

### **13.1 PROTECTION OF THE ENVIRONMENT**

Throughout the duration of the contract, the contractor must ensure that all persons under his responsibility take all necessary measures to protect the environment. More specifically, he must:

- Ensure that there will be no storage of materials, no circulation of machinery, no digging of trenches or any other unauthorized intervention that could damage or modify lakes and watercourses with regular or intermittent flow, their banks and



---

their respective flood plains or adjacent or isolated wetlands (ponds, marshes, swamps or peat bogs);

- Respect all the easements shown on the plans and take the necessary measures to prevent the machinery from circulating outside the easements that have been assigned to it. In no event shall the Contractor be authorized to negotiate additional easements on the lakes and watercourses, their respective shores and floodplains or in the adjacent or isolated wetlands;
- Preserve on the site all vegetation such as trees, shrubs and other herbaceous plants (including grassy areas) that do not interfere with the work. If the contractor damages the vegetation outside the planned easement, he must replace it at his expense, unless the restoration is included in the work (see section "Conservation of trees");
- Proceed as soon as possible and as the work progresses to restore disturbed areas (eg stabilization and revegetation of slopes and bare soils). Vegetation of disturbed soils should be done with native species preferably. The restoration elements must ensure that the environment will be equivalent or improved compared to the situation prior to the intervention;
- Make sure not to throw, spill or allow to escape onto the ground or into waterways organic or inorganic materials or petroleum products and their derivatives (antifreeze or solvent). An intervention kit for the recovery of hazardous materials must be present on the site. Any spill of contaminants must be the subject of immediate response measures to confine, recover and dispose of the products in accordance with the Environment Quality Act (EQA) and the policies and regulations of the Minister du Sustainable Development, Environment and the Fight against Climate Change (MELCC) in the manner approved by the engineer. In all cases of spills, Urgence-Environnement must be notified immediately at 1-866-694-5454, in accordance with section 21 of the LQE;
- Maintain machinery (oil change, etc.) at a minimum distance of 30 m from a lake, stream or wetland (ponds, marshes, swamps or peat bogs). The machinery must be cleaned to remove excess oil or grease before starting shore work, and it must also be inspected regularly for leaks. Biodegradable hydraulic fluids are recommended for work in these sensitive environments or near them;
- Clean the machinery before arriving at the work site to remove the mud, plant fragments and animals attached to it;
- Do not use pesticides (herbicides, fungicides, insecticides, etc.), unless you have obtained appropriate authorization from the regional directorate of the MELCC.
- Take all the necessary measures and build all the necessary facilities and use the appropriate mitigation measures to avoid contamination of lakes and streams with new, used or excavated materials found on the site;

- 
- When there is pumping of the water found at the bottom of an excavation or work area, pumping water can be discharged directly into the watercourse if it does not contain suspended solids beyond the background noise and visible to the naked eye. Otherwise, the contractor must provide a system to avoid the suction of sediment and discharge water into an infiltration area, outside the shore of any lake or watercourse. However, if the amount of water pumped is too large for it to fully infiltrate the soil before it reaches the water body, then the water must be pumped into a sedimentation tank. The sedimentation basin must be set up outside the shoreline of the lake, watercourse or wetland (pond, marsh, swamp or bog). The water discharged at the outlet of the sedimentation tank must not contain suspended matter beyond the background noise and visible to the naked eye;
  - Use recognized control methods to avoid or control the production of dust and smoke and any atmospheric pollution on the work site. The dust suppressants used must comply

### **13.2 MANAGEMENT OF EXCAVATION AND BACKFILL MATERIALS**

Throughout the duration of the contract, the contractor must ensure that any person under his responsibility takes all the measures necessary to adequately dispose of excavation and backfill materials. More specifically, he must:

- Ensure that all excavated materials that are not reused, including in particular sawn timber, rubble and plaster, concrete and masonry pieces as well as pieces of paving, are managed (by treatment, recovery or disposal) in accordance with Environment Quality Act, Regulation respecting the burial and incineration of residual materials and the Regulation respecting hazardous materials. If necessary, the contractor must himself find the place of disposal and submit it to the approval of the engineer;
- Ensure that all excavation and backfill materials are managed in accordance with the interim grid for the management of excavated contaminated soil presented in the Policy for the protection of soil and the remediation of contaminated land, the Regulation respecting the burial of contaminated soil and the Regulation respecting the storage and transfer centers of contaminated soil;
- Ensure that excavation materials are available outside lakes and watercourses with regular or intermittent flow, their respective shores, flood plains and wetlands;

Provide the engineer with written proof that the materials from the site have been deposited in an authorized location.

### **13.3 DISPOSAL OF EXCAVATION SURPLUSES**

All of the cuttings storage and disposal sites (excavation surplus excluding any waste) envisaged for the realization of this contract must be approved beforehand by the engineer, at the latest at the first site meeting. No disposal of these materials can be made without obtaining this approval.

All excess excavation disposal sites will be subject to adequate leveling and revegetation to the satisfaction of the Consultant.

Excavation surpluses must be placed outside the aquatic environment as defined above and including any wetland, any shore, any coastline, any flood plain as well as the bed of any body of water.

#### **13.4 PRESERVATION OF TREES**

The Contractor is held responsible for any damage caused to the trees to be preserved located on all the sites of the contract and must replace each damaged tree either by a tree of the same essence and of the same dimension, or by a tree of the same essence of 150 mm diameter and eight meters in height, and must guarantee its survival for a period of two years after acceptance of the contract.

The trees to be protected must also have a protected area around them, with a radius of five meters.

In the event that this minimum surface cannot be respected, the following technique must be applied which minimizes soil compaction, the effects of which are harmful to the health of trees: it involves spreading over the surface used, a non-woven geotextile membrane and place a 20 cm high earth cushion on it.

When there is an accidental nick of part of the root system, which is observed only during the execution of the work, an equal portion of branches must be pruned by a specialist.

A specialist must see the pruning and the necessary care during the works. The specialist's contact details must appear on the list of subcontractors.

# **SECTION 3**

**Pictures of the site**































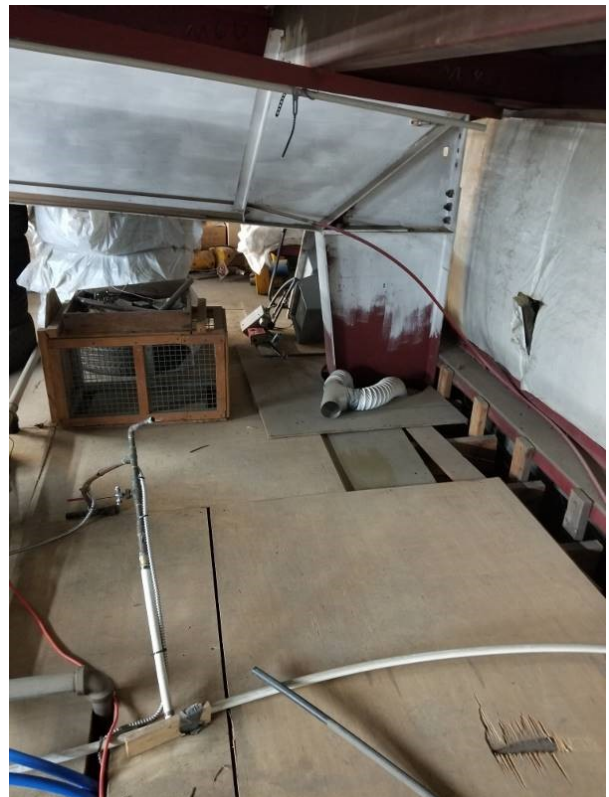



# LÉGENDE

Existant	Projeté

AUTRES PROFESSIONS

## NOTES

- 1) LE DIAMÈTRE DES CONDUITES EST DONNÉ EN VALEURS NOMINALES.
- 2) LA POSITION ET L'ÉLEVATION DES STRUCTURES ET SERVICES EXISTANTS QUI APPARAÎSSENT AUX PLANS PEUVENT DIFFÉRER. L'ENTREPRENEUR DOIT EN VÉRIFIER L'EXACTITUDE AU CHANTIER.
- 3) TOUTS LES MATÉRIEAUX GRANULAIRES DOIVENT RÉPONDRE AUX EXIGENCES SPÉCIFIÉES DANS LES CLAUSES TECHNIQUES DU "CAHIER DES CHARGES ET DEVS GÉNÉRAUX" DU MINISTÈRE DES TRANSPORTS DU QUÉBEC.
- 4) L'AQUEDUC EST À 2m SOUS LE PAVAGE MESURÉ DU DESSUS DE LA CONDUITE. DANS LE CAS OÙ CETTE COUVERTURE MINIMALE N'EST PAS RESPECTÉE, UN ISOLANT ROUGE DE TYPE H-60 DOIT ÊTRE INSTALLÉ.
- 5) L'AQUEDUC DOIT ÊTRE MUNI D'UN PL. LOCALISATEUR.
- 6) LES VANNES DES POTEAUX D'ÉCRICOLE SONT INSTALLÉES À 1.0m DE LA CONDUITE PRINCIPALE.
- 7) L'EMPLACEMENT DES SERVICES MUNICIPAUX ET DES SERVICES PUBLICS (E.L., GAZ, HYDRO-QUÉBEC, ET AUTRES) MONTRÉ AU PLAN EST APPROXIMATIF ET EST ASSUMÉ LINÉAIRE ENTRE LES POINTS APPRÉHÉS SUR LE TERRAIN. L'ENTREPRENEUR EST RESPONSABLE DE FAIRE LOCALISER LES SERVICES PUBLICS AVANT DE DÉBUTER LES TRAVAUX.
- 8) LES LIMITES DE LOT SONT APPROXIMATIVES. DES BORNES D'ARPENTAGE DOIVENT ÊTRE MISES EN PLACE AVANT LES TRAVAUX.

**INTÉRESSÉMENT**  
 LES DIMENSIONS ET LES LONGUEURS MONTRÉES AU PLAN SONT EN MÈTRES POUR LES CONDUITES.  
 SUITE À LA REPRODUCTION, L'ÉCHELLE INDICUÉE PEUT DIFFÉRER DES DIMENSIONS SUR LE PLAN.  
 L'ENTREPRENEUR NE PEUT DÉBUTER LES TRAVAUX SANS AVOIR EU LES PLANS IDENTIFIÉS "ÉMIS POUR CONSTRUCTION".  
 L'ENTREPRENEUR EST TENU DE VÉRIFIER LA CONCORDANCE DES DIFFÉRENTS REPERES ALTMÉTRIQUE ET GÉODÉSIIQUES (B.M.) AVANT LE DÉBUT DES TRAVAUX.

REV.	Description	Date
01	POUR SOUMISSION / FOR SUBMISSION	11-08-20.
00	POUR COMMENTAIRE / FOR COMMENTS	10-08-20.

Consultant

2031, rue Léonard-De Vinci  
 Suite 100  
 Sainte-Julie, (Qc.) J3E 1Z2  
 Tel: 514-316-3443  
 genexco.ca

Client: Ferme de recherches de Freighsburg  
 Freighsburg Experimental Farm

Dessiné par: Philippe Surprenant Tech.  
 Préparé par: Stéphane Bélanger Ing.  
 Vérifié par: [Signature]

Projet: Réfection du drainage  
 Titre du plan: Travaux projetés / Proposed project

Localisation: 57 Chemin de Saint-Armand, Freighsburg

Échelle: 1:250	Date: 16-12-19.	Format papier: A1
Dossier: GEN20-1002	N° de dessin: GEN20-1002-01	2
		3

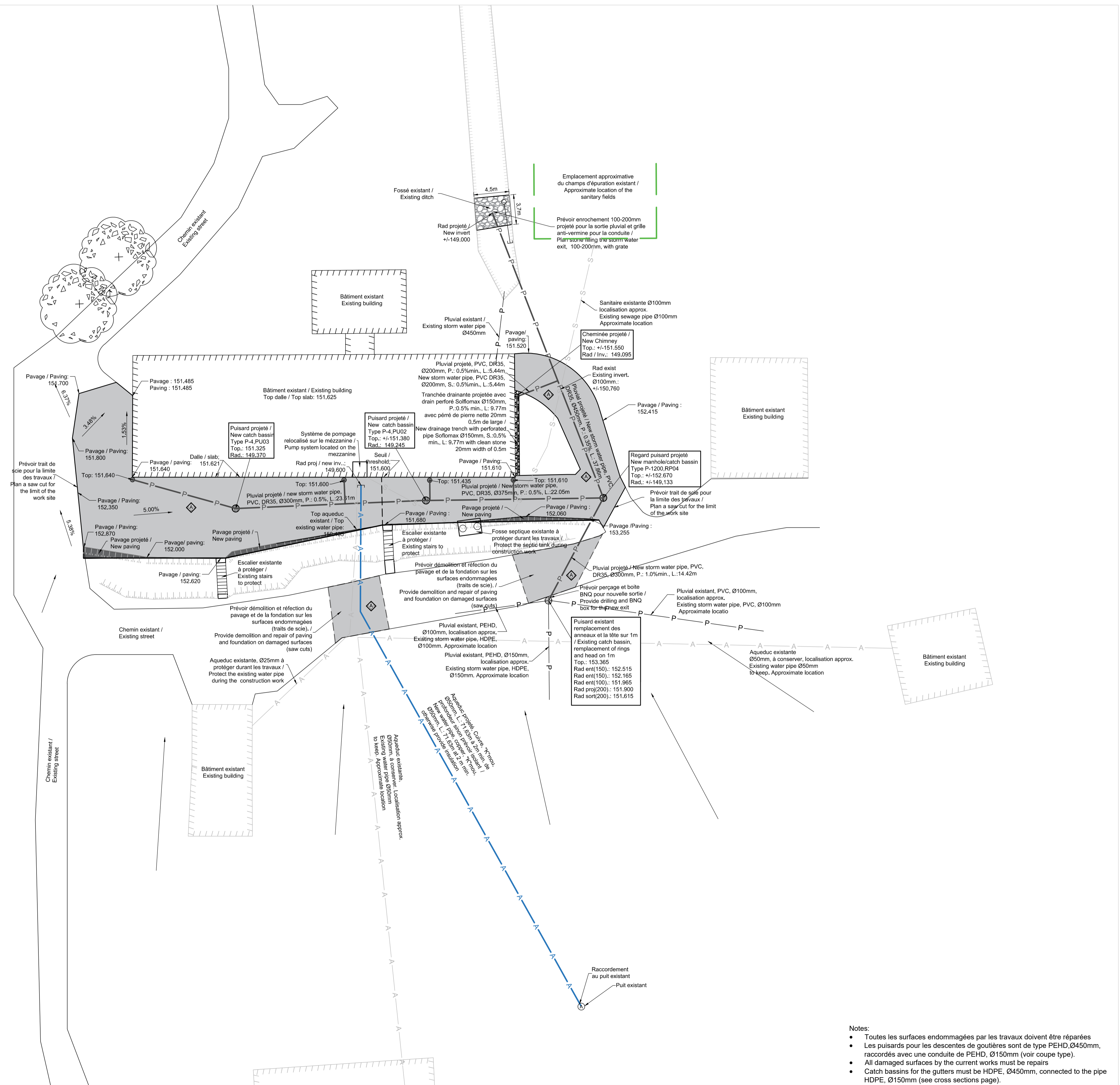

- Notes:
- Toutes les surfaces endommagées par les travaux doivent être réparées
  - Les puisards pour les descentes de gouttières sont de type PEHD, Ø450mm, raccordés avec une conduite de PEHD, Ø150mm (voir coupe type).
  - All damaged surfaces by the current works must be repairs
  - Catch basins for the gutters must be HDPE, Ø450mm, connected to the pipe HDPE, Ø150mm (see cross sections page).

**TRANCHÉE (HORS CHAUSSEE)  
TRENCH (OFF-ROAD)**

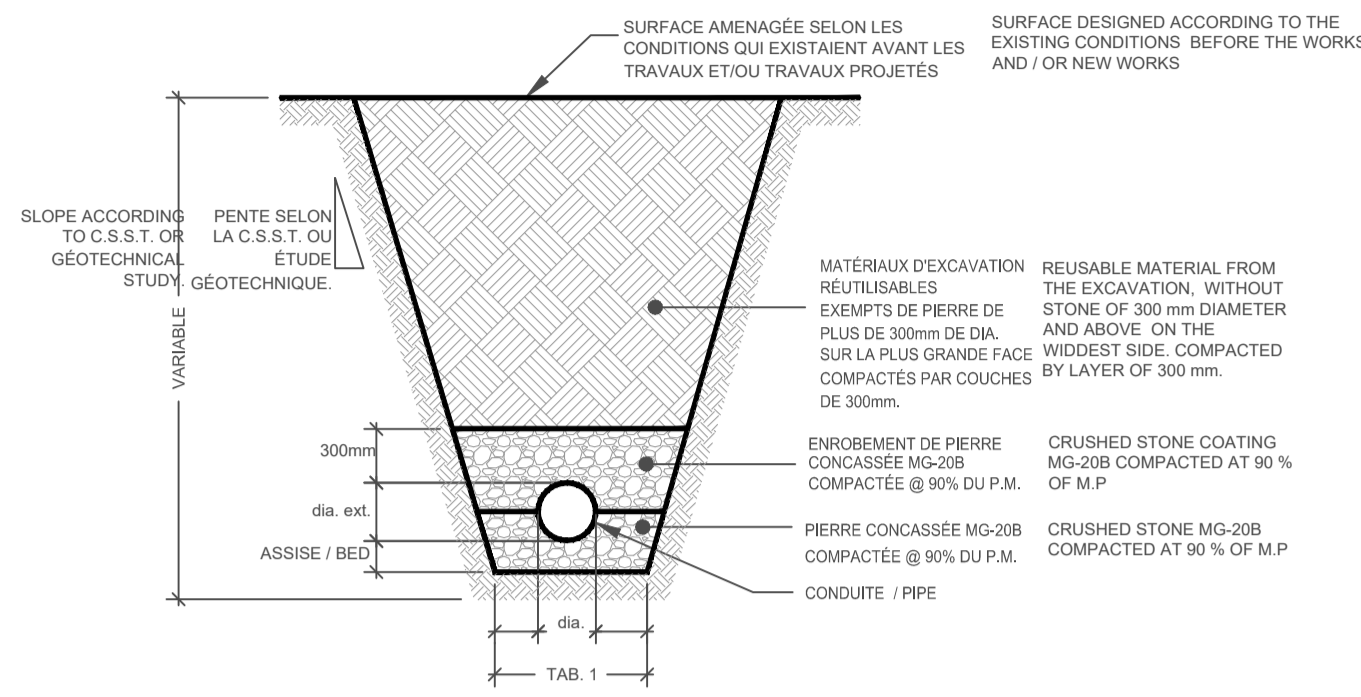

DIAMÈTRE / DIAMETER NOMINAL	EXCAVATION DANS UN MATÉRIAU AUTRE QUE LE ROC (CAS DE TRANCHÉE 2 VERT. 1 HOR.) EXCAVATION IN A MATERIAL OTHER THAN ROC (TRENCH CASE 2 VERT. 1 HOR.)	
	ASSISE / BED (mm) MIN.	LARGEUR DU FOND DE LA TRANCHÉE / TRENCH BOTTOM WIDTH (mm) MIN.
300 et moins / and less	150	Dext + 900
De 350 à 600	150	Dext + 900
De 750 à 1200	200	Dext + 1200
De 1350 à 1500	250	Dext + 1200
1800 et plus / and more	300	a) Dext + 1200, si la tranchée est élargie / if the trench is sealed b) Dext + 900, si la tranchée n'est pas élargie / if the trench is not sealed

TAB. 1

**TRANCHÉE (SOUS CHAUSSEE) / TRENCH (UNDER ROAD)**

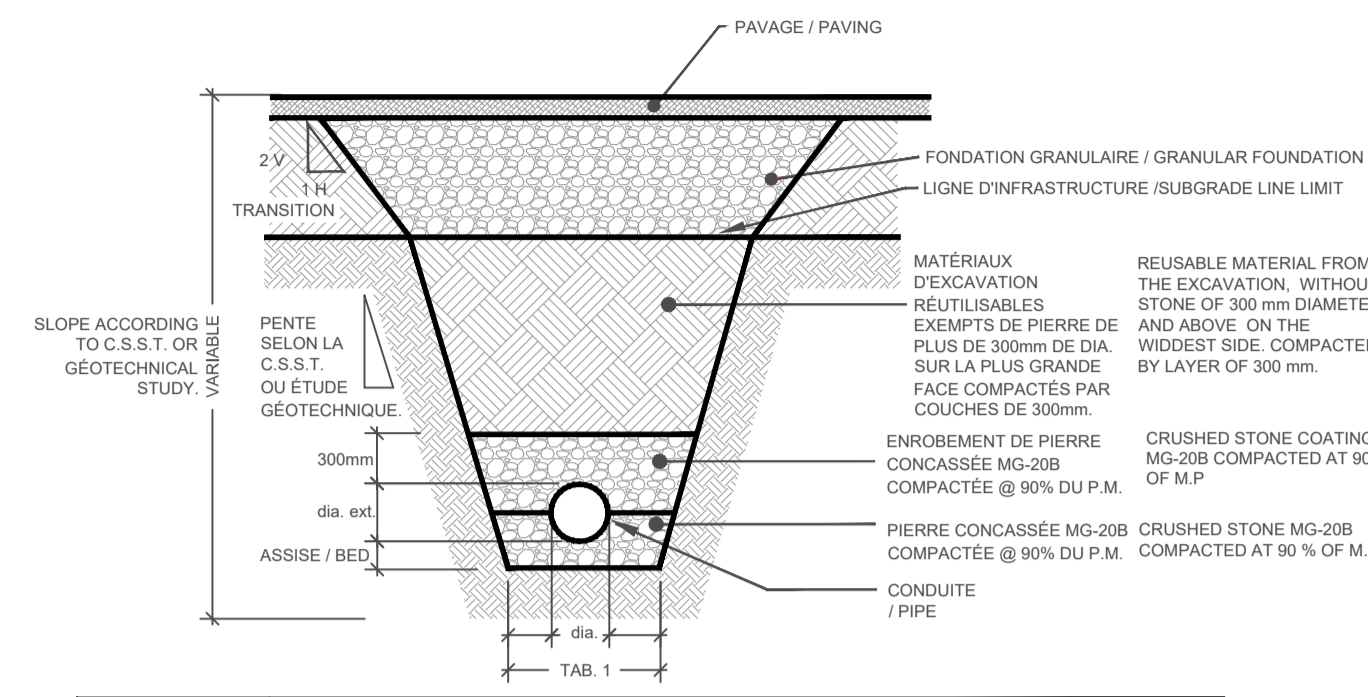

DIAMÈTRE / DIAMETER NOMINAL	EXCAVATION DANS UN MATÉRIAU AUTRE QUE LE ROC (CAS DE TRANCHÉE 2 VERT. 1 HOR.) EXCAVATION IN A MATERIAL OTHER THAN ROC (TRENCH CASE 2 VERT. 1 HOR.)	
	ASSISE / BED (mm) MIN.	LARGEUR DU FOND DE LA TRANCHÉE / TRENCH BOTTOM WIDTH (mm) MIN.
300 et moins / and less	150	Dext + 900
De 350 à 600	150	Dext + 900
De 750 à 1200	200	Dext + 1200
De 1350 à 1500	250	Dext + 1200
1800 et plus / and more	300	a) Dext + 1200, si la tranchée est élargie / if the trench is sealed b) Dext + 900, si la tranchée n'est pas élargie / if the trench is not sealed

TAB. 1

**PUISARD ET REGARD AVEC SAIGNÉE  
CATCH BASIN AND MANHOLE WITH DRAINS**

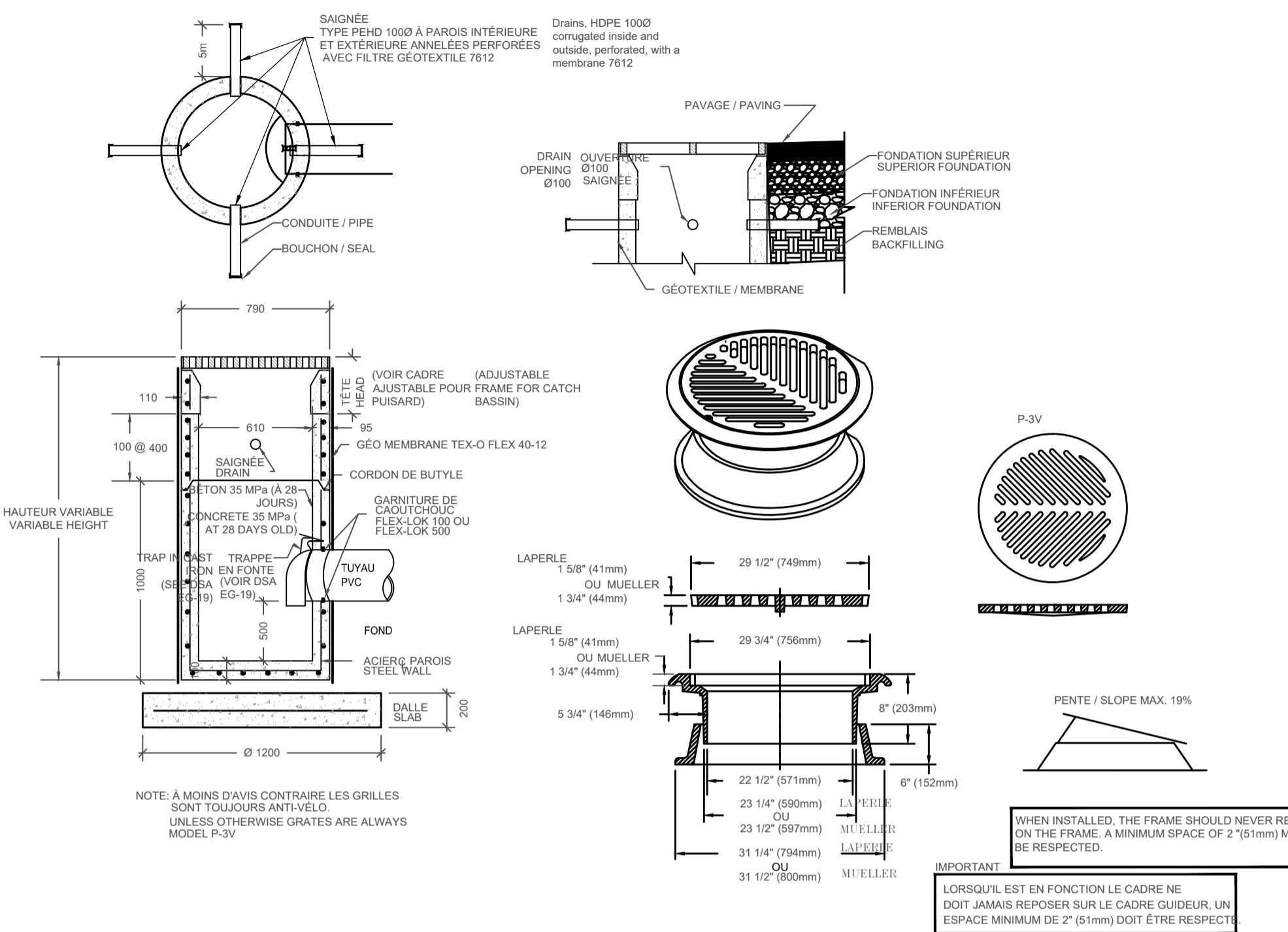

MODELE	FABRIQUANT	MATERIAUX	POIDS
GRILLE ANTI-VELO P-3V / GRATE P-3V	LAPERLE	FRONTE DUCTILE	180 Lb / 82 Kg
GRILLE ANTI-VELO A750BD / GRATE A750BD	MUELLER	FRONTE DUCTILE	188 Lb / 85 Kg
CADRE AJUSTABLE C50P / ADJUSTABLE FRAME C50P	LAPERLE	FRONTE DUCTILE	150 Lb / 68 Kg
CADRE AJUSTABLE A750BD / ADJUSTABLE FRAME A750BD	MUELLER	FRONTE DUCTILE	192 Lb / 87 Kg
GUIDEUR CONIQUE CQ29-5P / GUIDING FRAME CQ29-5P	LAPERLE	FRONTE GRISE	95 Lb / 43 Kg
GUIDEUR CONIQUE A750GC / GUIDING FRAME A750GC	MUELLER	FRONTE GRISE	136 Lb / 61 Kg

**STATIONNEMENT AVEC PAVAGE, FONDATION GRANULAIRE  
PARKING WITH PAVING AND GRANULAR FOUNDATION  
(LIGHT CIRCULATION)**

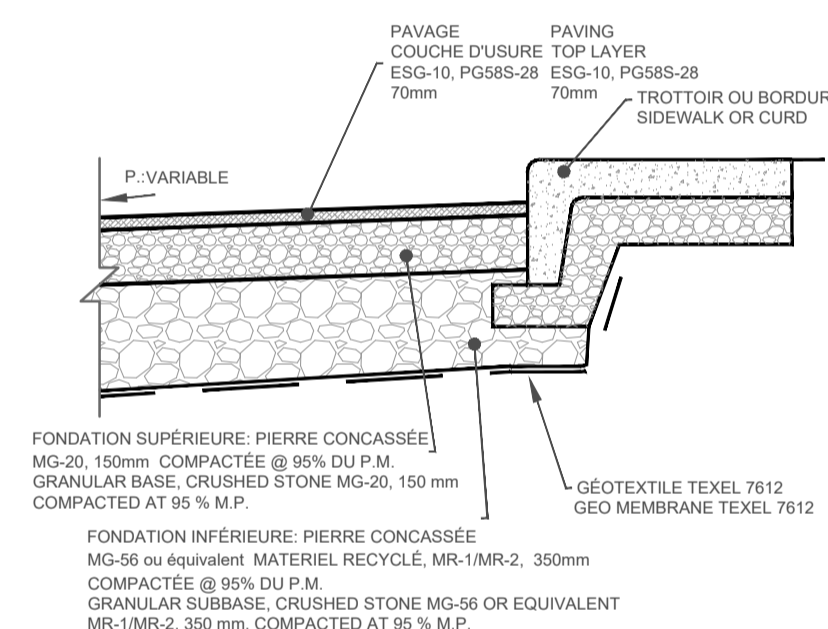

**DÉTAIL TYPE DE PERRÉ DE PROTECTION  
TYPICAL DETAIL RIPRAP**

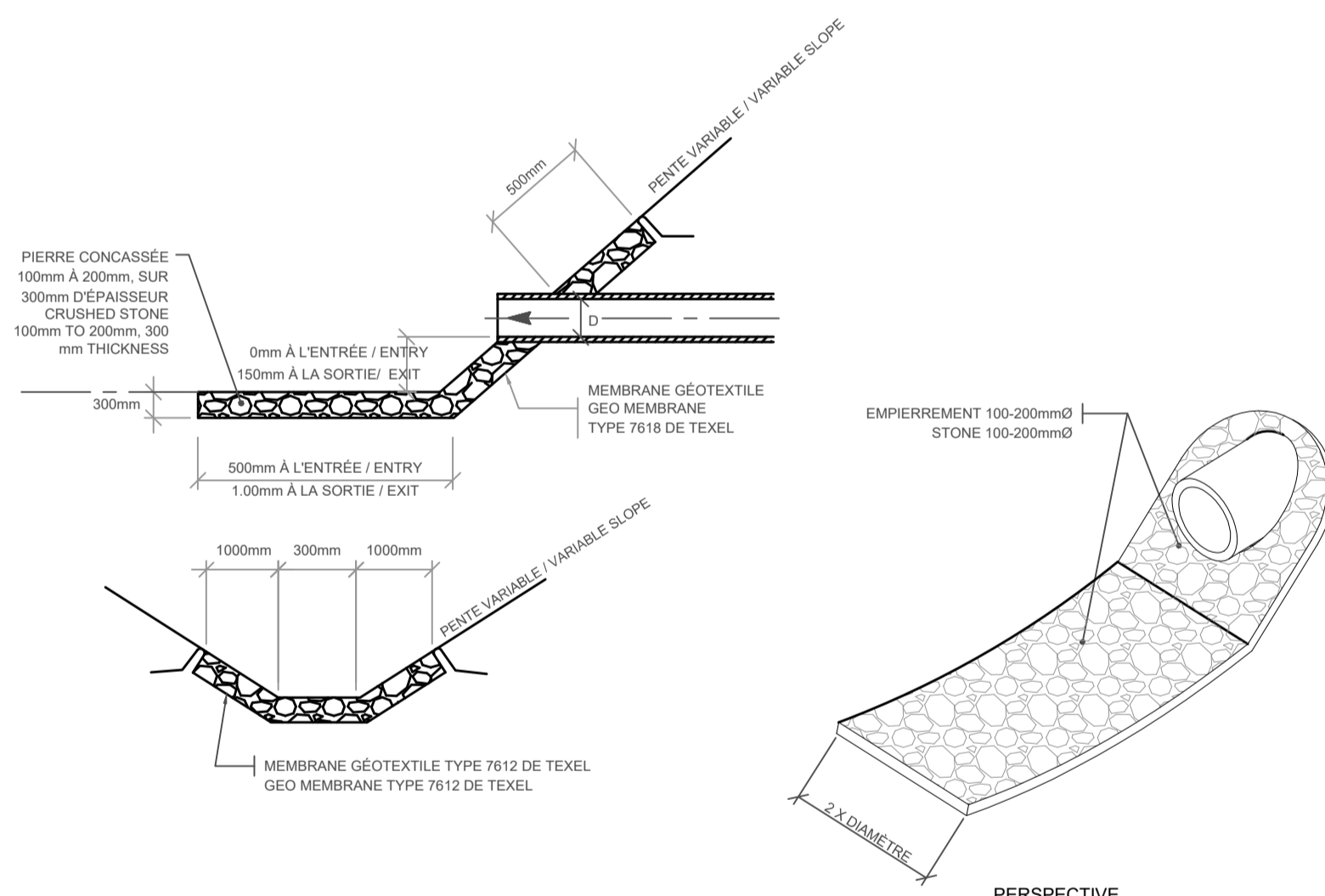

**TRANCHÉE DRAINANTE / DRAINAGE TRENCH**

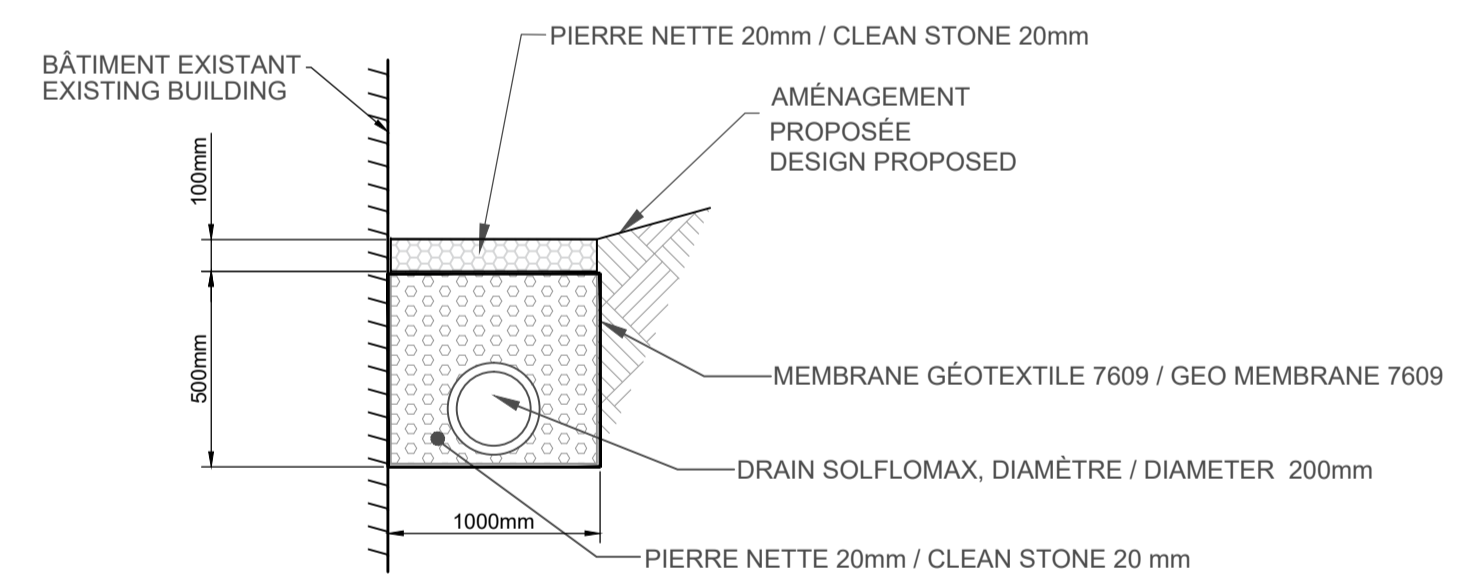

**CONDUITE AVEC ISOLANT / PIPE WITH INSULATION**

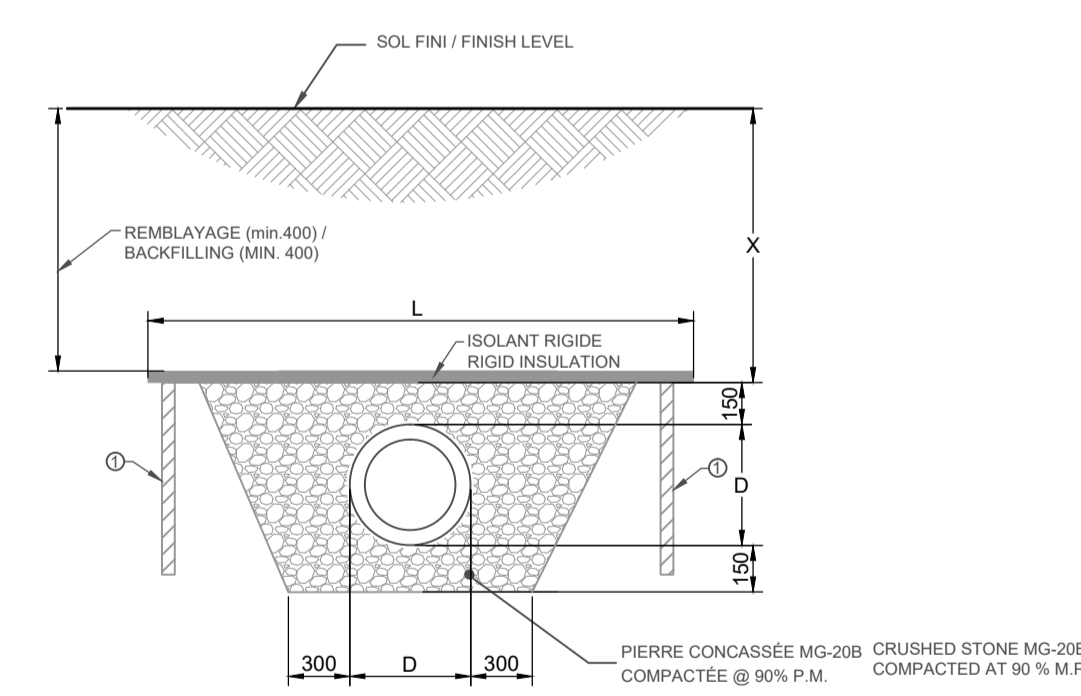

X	1600	1500	1400	1300	1200	1100	1000	900	800	700	600	500
ÉPAISSEUR DE L'ISOLANT / THICKNESS (mm)	25	25	50	50	50	50	50	50	75	75	75	75
D=DIAMÈTRE (mm)												
150 @250	600	600	1200	1200	1200	1800	1800	1800	2400	2400	2400	3000
300 @ 450	600	1200	1200	1200	1800	1800	1800	2400	2400	2400	3000	3000
500 @600	1200	1200	1200	1800	1800	1800	2400	2400	2400	3000	3000	3000
1200	1800	1800	1800	2400	2400	2400	3000	3000	3000	3600	3600	3600
1500	1800	2400	2400	2400	3000	3000	3600	3600	3600	4800	4800	4800

L'ISOLANT UTILISÉ SERA DE TYPE POLYURÉTHANE EXTRUDÉ "STYROFOAM HI-60, TEL QUE FABRIQUÉ PAR DOW CHEMICAL CO." OU ÉQUIVALENT APPROUVÉ.

NOTE: 1: DANS LE CAS OÙ UN OUVRAGE À L'AIR LIBRE (REGARD, PUISARD ETC.) SE TROUVE À CÔTÉ DE LA CONDUITE, LES MÊMES CRITÈRES SONT RESPECTÉS, MAIS DE FAÇON LATÉRALE. L'INSTALLATION DE L'ISOLANT SE FERA AVEC LA DISTANCE "X" DU TABLEAU CI-DESSUS, MAIS CALCULÉE LATÉRALEMENT ENTRE L'EXTÉRIEUR DE LA CONDUITE ET L'OUVRAGE NON ISOLÉ.

THE INSULATION USED SHOULD BE EXTRUDED POLYURETHANE TYPE "STYROFOAM HI-60, AS MANUFACTURED BY DOW CHEMICAL CO." OR APPROVED EQUIVALENT.

NOTE 1: IN THE CASE, AN OPENING UNIT (MANHOLE, SUMP, ETC.) IS NEXT TO THE DUCT, THE SAME CRITERIA SHALL BE RESPECTED, BUT LATERAL. THE INSULATION INSTALLATION WILL BE DONE WITH THE DISTANCE "X" IN THE TABLE ABOVE, BUT CALCULATED LATERALLY BETWEEN THE OUTSIDE OF THE DUCT AND THE NON-INSULATED WORK.

**GOUTTIÈRE ET PUISARD PROJETÉ / GUTTER AND CATCH BASIN**

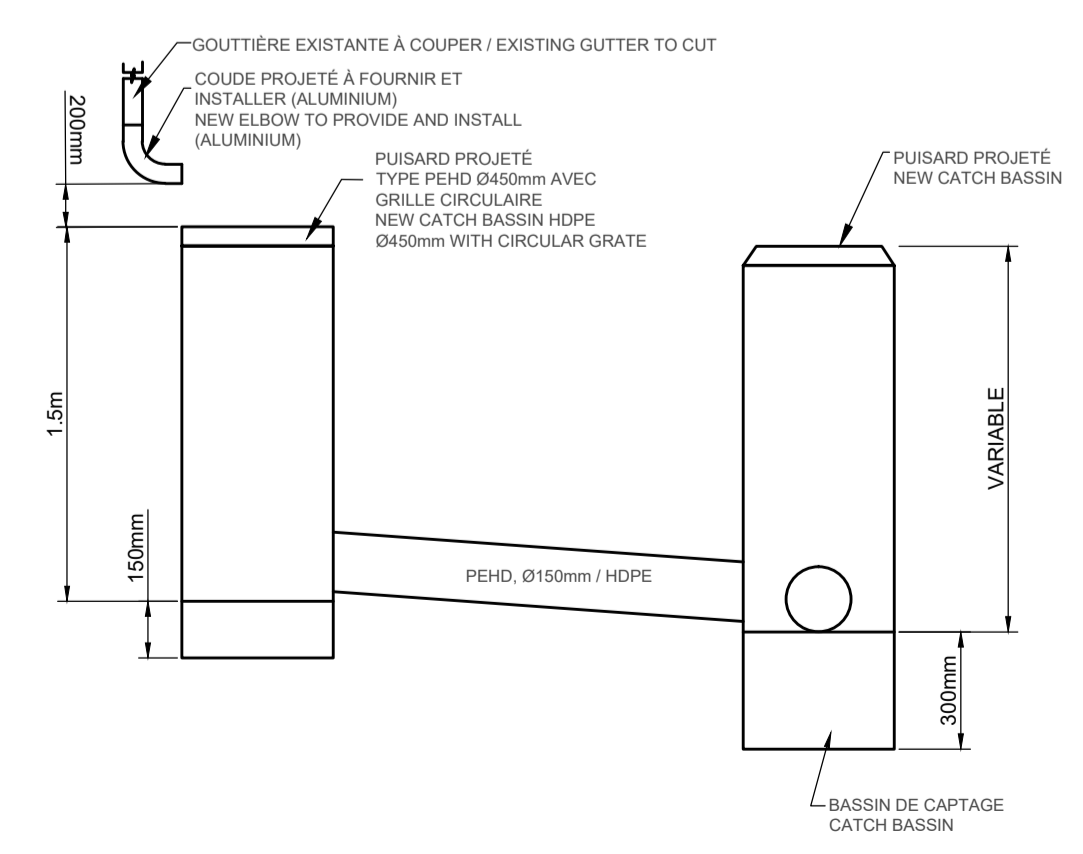

**LÉGENDE**

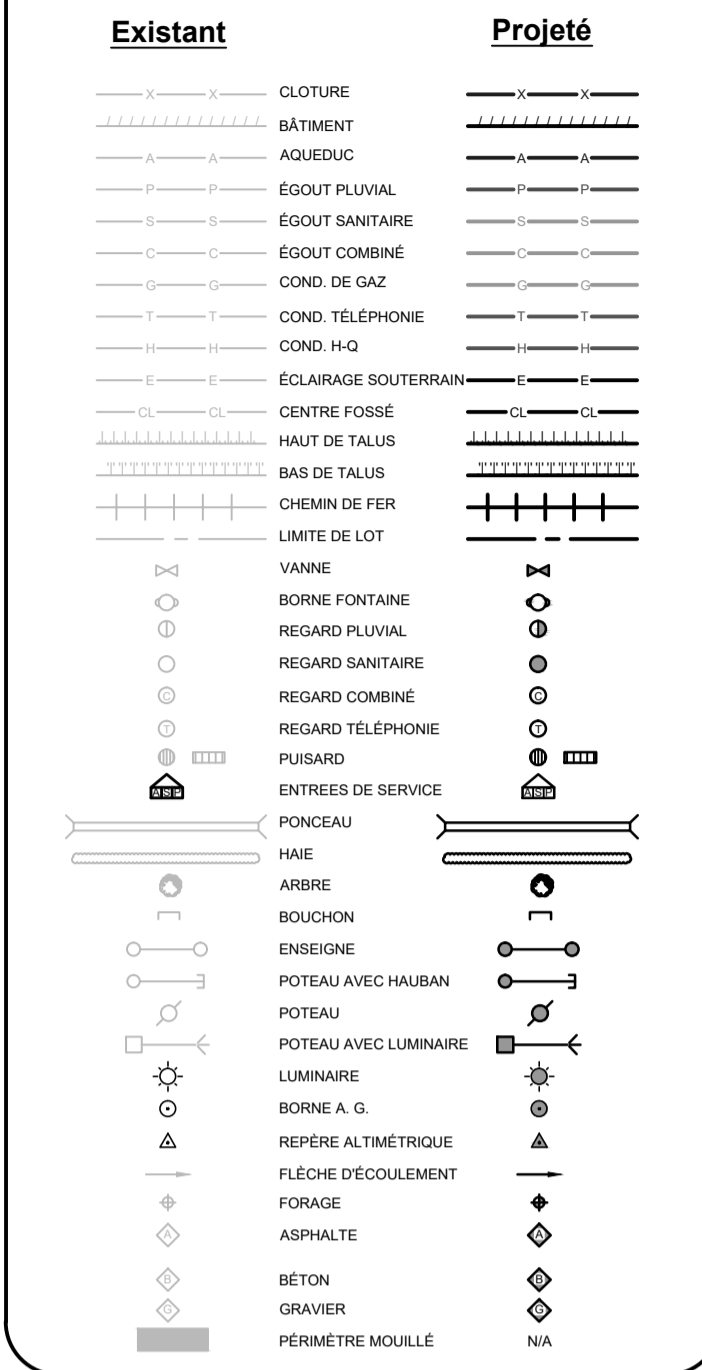

IMPORTANT  
LORSQU'IL EST EN FONCTION LE CADRE NE DOIT JAMAIS REPOSER SUR LE CADRE GUIDEUR, UN ESPACE MINIMUM DE 2" (51mm) DOIT ÊTRE RESPECTÉ.

**NOTES**

- 1) LE DIAMÈTRE DES CONDUITES EST DONNÉ EN VALEURS NOMINALES.
- 2) LA POSITION ET L'ÉLEVATION DES STRUCTURES ET SERVICES EXISTANTS QUI APPARAÎSENT AUX PLANS PEUVENT DIFFÉRER. L'ENTREPRENEUR DOIT EN VÉRIFIER L'EXACTITUDE AU CHANTIER.
- 3) TOUTS LES MATÉRIEAUX GRANULAIRES DOIVENT RÉPONDRE AUX EXIGENCES SPÉCIFIÉES DANS LES CLAUSES TECHNIQUES DU "CAHIER DES CHARGES ET DEVIS GÉNÉRAUX" DU MINISTÈRE DES TRANSPORTS DU QUÉBEC.
- 4) L'AQUÉDUC EST À 2m SOUS LE PAVAGE MESURÉ DU DESSUS DE LA CONDUITE. DANS LE CAS OÙ CETTE COUVERTURE MINIMALE N'EST PAS RESPECTÉE, UN ISOLANT RIGIDE DE TYPE HI-60 DOIT ÊTRE INSTALLÉ.
- 5) L'AQUÉDUC DOIT ÊTRE MUNI D'UN PL LOCALISATEUR.
- 6) LES VANNES DES POTAUX D'ÉCHOUÉ SONT INSTALLÉES À 1.0m DE LA CONDUITE PRINCIPALE.
- 7) LE SPACIEMENT DES SERVICES MUNICIPAUX ET DES SERVICES PUBLICS (E.L.L. GAZ, HYDRO-QUÉBEC, ET AUTRES) MONTRÉ AU PLAN EST APPROXIMATIF ET EST ASSUMÉ LINÉAIRE ENTRE LES POINTS APPARENTS SUR LE TERRAIN. L'ENTREPRENEUR EST RESPONSABLE DE FAIRE LOCALISER LES SERVICES PUBLICS AVANT DE DÉBUTER LES TRAVAUX.
- 8) LES LIMITES DE LOT SONT APPROXIMATIVES. DES BORNES D'ARPENTAGE DOIVENT ÊTRE MISES EN PLACE AVANT LES TRAVAUX.

LES DIMENSIONS ET LES LONGUEURS MONTRÉES AU PLAN SONT EN MÈTRES POUR LES CONDUITES. SUITE À LA REPRODUCTION, L'ÉCHELLE INDICÉE PEUT DIFFÉRER DES DIMENSIONS SUR LE PLAN. L'ENTREPRENEUR NE PEUT DÉBUTER LES TRAVAUX SANS AVOIR EU LES PLANS IDENTIFIÉS "ÊMIS POUR CONSTRUCTION". L'ENTREPRENEUR EST TENU DE VÉRIFIER LA CONCORDANCE DES DIFFÉRENTS REPERES ALTIMÉTRIQUES ET GÉODÉSINIQUES (M) AVANT LE DÉBUT DES TRAVAUX.

REV.	Description	Date
01	POUR SOUMISSION / FOR SUBMISSION	11-08-20.
02	POUR COMMENTAIRE / FOR COMMENTS	10-08-20.

Consultant  
  
 2031, rue Léonard-De Vinci  
 Suite 100  
 Sainte-Julie, (Qc.) J3E 1Z2  
 Tel: 514-316-3443  
 genexco.ca

Client  
**Ferme de recherches de Freilighsburg**  
 Freilighsburg Experimental Farm

Drawn par: **Philippe Surprenant Tech.**  
 Préparé par: **Stéphane Bélanger Ing.**  
 Vérifié par: [Signature]

Projet: **Réfection du drainage / drainage correction**

Titre du plan: **Coupes types / Cross sections**

Localisation: **57 Chemin de Saint-Armand, Freilighsburg**

Échelle: N/A	Date: 16-12-19.	Format papier: A1
Dossier: GEN20-1002	N° de dessin: GEN20-1002-01	3



## **Appendix "F"**

### **INSURANCE TERMS**

## INSURANCE TERMS

### IN1    GENERAL

- IN1.1    Worker's Compensation
- IN1.2    Indemnification
- IN1.3    Proof of Insurance
- IN1.4    Insured
- IN1.5    Payment of Deductible

### IN2    COMMERCIAL GENERAL LIABILITY

- IN2.1    Scope of Policy
- IN2.2    Period of Insurance

### IN3    AUTOMOBILE INSURANCE

- IN3.1    Scope of Policy

### IN4    BUILDER'S RISK / INSTALLATION FLOATER

- IN4.1    Scope of Policy
- IN4.2    Amount of Insurance
- IN4.3    Period of Insurance
- IN4.4    Insurance Proceeds

## IN1    GENERAL

### IN1.1    Worker's Compensation

- 1) The Contractor shall provide and maintain Worker's Compensation Insurance in accordance with the legal requirements of the Province or Territory where the work is being carried out.

### IN1.2    Indemnification

- 1) The insurance required by the provisions of these Insurance Terms shall in no way limit the Contractor's responsibility under the Indemnification clause of the General Conditions of the contract. Any additional coverage the Contractor may deem necessary to fulfill his obligations under the aforesaid clause shall be at his own discretion and expense.

### IN1.3    Proof of Insurance

- 1) Before commencement of the Work, and within thirty (30) days after acceptance of its bid, the Contractor shall deposit with Canada a CERTIFICATE OF INSURANCE (form AAFC / AAC5314) available upon request.
- 2) In the event that the Contractor already possesses an insurance certificate clearly demonstrating that their insurance coverage meets IN2.1 Scope of Policy provisions, then the Contractor may deposit an original copy of this insurance certificate.
- 3) Upon request by Canada, the Contractor shall provide originals or certified true copies of all contracts of insurance maintained by the Contractor pursuant to the provisions contained herein.

### IN1.4    Insured

- 1) Each policy shall insure the Contractor and shall include Her Majesty the Queen in right of Canada, represented by the Minister of Agriculture & Agri-Food Canada as an additional Insured, with respect to liability arising out of the operations of the contractor with regard to the work.

## **INSURANCE TERMS (Continued)**

### **IN1.5 Payment of Deductible**

- 1) The payment of monies up to the deductible amount made in satisfaction of a claim shall be borne by the Contractor.

## **IN2 COMMERCIAL GENERAL LIABILITY**

### **IN2.1 Scope of Policy**

- 1) The insurance coverage provided shall not be less than that provided by IBC Form 2100, as amended from time to time, and shall have:
  - (a) an Each Occurrence Limit of not less than \$5,000,000.00 ;
  - (b) a Products/Completed Operations Aggregate Limit of not less than \$5,000,000.00 ; and
  - (c) a General Aggregate Limit of not less than \$10,000,000.00 per policy year, if the policy is subject to such a limit.
- 2) The policy shall either include or be endorsed to include coverage for the following exposures or hazards if the Work is subject thereto:
  - (a) Blasting.
  - (b) Pile driving and caisson work.
  - (c) Underpinning.
  - (d) Removal or weakening of support of any building or land whether such support be natural or otherwise if the work is performed by the insured contractor.
  - (e) Asbestos.
  - (f) Non-owed Automobile Policy.

### **IN2.2 Period of Insurance**

- 1) Unless otherwise directed in writing by Canada, or, otherwise stipulated elsewhere herein, the policy required herein shall be in force and be maintained from the date of contract award until the day of issue of the Certificate of Completion except that the coverage for Completed Operations Liability shall, in any event, be maintained for a period of at least six (6) years beyond the date of the CERTIFICATE OF SUBSTANTIAL PERFORMANCE.

## **IN3 AUTOMOBILE INSURANCE**

### **IN3.1 Scope of Policy**

- 1) Automobile Liability Insurance in respect of licensed vehicles shall have limits of not less than one million dollars inclusive per occurrence for bodily injury, death, and damage to property.



## **INSURANCE TERMS (Continued)**

### **IN4 BUILDER'S RISK / INSTALLATION FLOATER**

#### **IN4.1 Scope of Policy**

- 1) The insurance coverage provided by a Builder's Risk policy or an Installation Floater policy shall not be less than that provided by IBC Forms 4042 and 4047, as amended from time to time.
- 2) The policy shall permit use and occupancy of the project, or any part thereof, where such use and occupancy is for the purposes for which the project is intended upon completion.
- 3) The policy may exclude or be endorsed to exclude coverage for loss or damage caused by any of the following:
  - (a) Asbestos.
  - (b) Fungi or spores.
  - (c) Cyber.
  - (d) Terrorism.

#### **IN4.2 Amount of Insurance**

- 1) The amount of insurance shall not be less than the sum of the contract value plus the declared value (if any) set forth in the contract documents of all material and equipment supplied by Canada at the site of the project to be incorporated into and form part of the finished Work. If the value of the Work is changed, the policy shall be changed to reflect the revised contract value.

#### **IN4.3 Period of Insurance**

- 1) Unless otherwise directed in writing by Canada, or, stipulated elsewhere herein, the policy required herein shall be in force and be maintained from prior to the commencement of work until the day of issue of the CERTIFICATE OF SUBSTANTIAL PERFORMANCE.

#### **IN4.4 Insurance Proceeds**

- 1) The policy shall provide that the proceeds thereof are payable to Her Majesty or as Canada may direct in accordance with GC 10.2 Insurance Proceeds.
- 2) The Contractor shall, without delay, do such things and execute such documents as are necessary to effect payment of the proceeds.



## **Appendix "G"**

### **CONTRACT DOCUMENTS**

## MAJOR WORKS - CONTRACT DOCUMENTS

### SC01 CONTRACT DOCUMENTS

- 1) The following are the contract documents:
  - (a) Contract page when signed by Canada;
  - (b) Duly completed Bid and Acceptance Form and any Appendices attached thereto;
  - (c) Drawings and Specifications;
  - (d) AAFC General Conditions form AAFC / AAC5321-E:
    - (i) GC1 General Provisions
    - (ii) GC2 Administration of the Contract
    - (iii) GC3 Execution and Control of the Work
    - (iv) GC4 Protective Measures
    - (v) GC5 Terms of Payment
    - (vi) GC6 Delays and Changes in the Work
    - (vii) GC7 Default, Suspension or Termination of Contract
    - (viii) GC8 Dispute Resolution
    - (ix) GC9 Contract Security
    - (x) GC10 Insurance
  - (e) Supplementary Conditions, if any;
  - (f) Insurance Terms form AAFC / AAC5315-E;
  - (g) Any amendment issued or any allowable bid revision received before the date and time set for solicitation closing;
  - (h) Any amendment incorporated by mutual agreement between Canada and the Contractor before acceptance of the bid; and
  - (i) Any amendment or variation of the contract documents that is made in accordance with the General Conditions.
- 2) The language of the contract documents shall be the language of the Bid and Acceptance Form submitted.

### SC02 ACCEPTANCE AND CONTRACT

- 1) Upon acceptance of the Contractor's offer by Canada, a binding Contract shall be formed between Canada and the Contractor. The documents forming the Contract shall be the contract documents referred to in SC01 CONTRACT DOCUMENTS.



## **Appendix "H"**

### **CONTRACT**

## CONTRACT

### PURCHASING OFFICE

Agriculture and Agri-Food Canada  
 Eastern Service Centre  
 Tender Receiving Unit  
 2001 Robert-Bourassa Boulevard, Suite 671-TEN  
 Montréal, Quebec  
 H3A 3N2

**Your tender is accepted** to sell to Her Majesty the Queen in right of Canada, in accordance with the terms and conditions set out herein, referred to herein or attached hereto, the construction listed herein and on any attached sheets at the price or prices set out therefor.

Comments

Vendor / Firm Name and Address

Title		
Surface water drainage work around Building # 18 - Frelighsburg Experimental Farm.		
Solicitation / Contract No.		Date
01B46-20-045		
Client Reference No.		
File No.		
Financial Code(s)		
<input type="radio"/> GST <input type="radio"/> HST <input type="radio"/> QST		
F.O.B		
Destination		
Applicable Taxes		
Included		
Destination		
Invoices - Original and two copies to be sent to :		
Address Enquiries to:		
Telephone No.	Ext.	Fax No.
Total Estimated Cost	Currency Type	
	CAD	
For the Minister		
Signature		Date



## **Appendix "I"**

### **Guidance for Contractors Working in AAFC Buildings**



## Updated Guidance for Contractors Working in AAFC Buildings

- For the purposes of this document, the term Contractor will mean contractor, sub-contractor, consultants and sub-consultants. Contractors are responsible to ensure that all their hired sub-contractors also adhere to the requirements of this document.
- Prior to accessing AAFC building interiors, Contractors will hold a orientation meeting (tele or video conference) with AAFC Facility Manager and Project Manager, and the following will be agreed to in writing with the intent of maintain physical distancing:
  - Access/egress and material delivery door(s) for worksite.
  - Daily shift or specific occupancy times, including estimated number of personnel.
  - Construction or work zone limits.
  - Use of site: washrooms, drinking water, parking location, garbage and recycling disposal.
  - Protocol that whenever physical distancing cannot be achieved at the worksite, facial covering will be worn by all personnel involved (AAFC and Contractor).
- Contractors are to submit signed confirmation that they understand and will follow requirements set out in attached **COVID-19 Check List for Contractors Working in AAFC Buildings**.



## COVID-19 Check List for Contractors Working in AAFC Buildings

Prior to beginning contracted work in an AAFC building, Contractors are to submit signed confirmation that they and their hired subcontractors agree to the following:

- Contractor will follow **Canadian Construction Association's COVID-19 – Standardized Protocols for All Canadian Construction Sites**. (<https://www.cca-acc.com/covid-19-resources/>)
- All contractor personnel will complete Government of Canada's online **COVID-19 Symptom Self Assessment Tool** each day prior to work shift and will not come to AAFC site if Tool advises or recommends to self-isolate, stay at home or seek medical attention. (<https://www.canada.ca/en/public-health/services/diseases/coronavirus-disease-covid-19.html>)
- Advise AAFC Representative as soon as possible if any of Contractor's personnel who have worked in an AAFC building begin to exhibit flu-like symptoms.
- All contractor and hired sub-contract personnel will follow local, provincial and federal public health guidance and requirements including that of **Public Health Agency of Canada (PHAC) for Coronavirus disease (COVID-19): Prevention and risk**. (<https://www.canada.ca/en/public-health/services/diseases/2019-novel-coronavirus-infection/prevention-risks.html?topic=tilelink>)
- While on AAFC property, all Contractor and sub-contractors will comply to all posted signage in AAFC buildings, or advise AAFC Representative immediately if unable to comply.

These above mentioned requirements will be complied while conducting work in AAFC buildings for the duration of the contract.

---

Signature of Contractor Representative





## FORMS

- **Bid Bond**
- **Certificate of Insurance**
- **Labour and Material Payment Bond**
- **Performance Bond**
- **T4-A Certification**

## BID BOND

**BOND NUMBER:** \_\_\_\_\_

**AMOUNT:** \_\_\_\_\_

KNOW ALL PERSONS BY THESE PRESENTS, that \_\_\_\_\_ as Principal,  
hereinafter called the Principal, and \_\_\_\_\_ as Surety,

hereinafter called the Surety, are, subject to the conditions hereinafter contained, held and firmly bound unto Her Majesty the Queen in right of Canada as represented by the Minister of Agriculture and Agri-Food, as Obligee, hereinafter called the Crown, in the amount of

\_\_\_\_\_ dollars (\$ \_\_\_\_\_), lawful money of Canada, for the payment of which sum, well and truly to be made, the Principal and the Surety bind themselves, their heirs, executors, administrators, successors and assigns, jointly and severally, firmly by these presents.

SIGNED AND SEALED this \_\_\_\_\_ day of \_\_\_\_\_, 20\_\_.

WHEREAS, the Principal has submitted a written tender to the Crown, dated the \_\_\_\_\_ day of \_\_\_\_\_, 20\_\_,

for \_\_\_\_\_

NOW, THEREFORE, THE CONDITIONS OF THIS OBLIGATION are such that if:

- (a) the Principal, should his tender be accepted within the period specified by the Crown, or, if no period be specified, within sixty (60) days after closing date of the tender, does execute within a period specified by the Crown, or, if no period be specified therein, within fourteen (14) days after the prescribed forms are presented to him for signature, execute such further contractual documents, if any, as may be required by the terms of the tender as accepted, and does furnish a Performance Bond and a Labour and Material Payment Bond, each in the amount of 50% of the Contract price and satisfactory to the Crown, or other security acceptable to the Crown, or
- (b) the Principal does pay to the Crown the difference between the amount of the Principal's tender and the amount of the Contract entered into by the Crown for the work, supplies and services which were specified in the said tender, if the latter amount be in excess of the former,

then this obligation shall be void; otherwise it shall remain in full force and effect.

PROVIDED, HOWEVER, that the Surety and the Principal shall not be liable to the Crown for an amount greater than the amount specified in this bond.

PROVIDED FURTHER that the Surety shall not be subject to any suit or action unless such suit or action is instituted and process therefore served upon the Surety at its Head Office in Canada, within twelve (12) months from the date of this bond.

IN TESTIMONY WHEREOF, the Principal has hereto set its hand and affixed its seal, and the Surety has caused these presents to be sealed with its corporate seal duly attested by the signature of its authorized signing authority, the day and year first above written.

SIGNED, SEALED AND DELIVERED in the presence of:

\_\_\_\_\_  
Principal

\_\_\_\_\_  
Witness

\_\_\_\_\_  
Surety

Note: Affix Corporate seal if applicable.



### CERTIFICATE OF INSURANCE

To be completed by the Insurer

CONTRACT						
Description and location of work					Contract No.	
					Project No.	
INSURER			BROKER			
Company name			Company name			
Unit/Suite/Apt.	Street number	Number suffix	Unit/Suite/Apt.	Street number	Number suffix	
Street name			Street name			
Street type	Street direction	PO Box or Route Number	Street type	Street direction	PO Box or Route Number	
Municipality (City, Town, etc.)			Municipality (City, Town, etc.)			
Province/State	Postal/ZIP code		Province/State	Postal/ZIP code		
INSURED			ADDITIONAL INSURED			
Contractor name			Her Majesty the Queen in right of Canada as represented by the Minister of Agriculture and Agri-Food Canada.			
Unit/Suite/Apt.	Street number	Number suffix				
Street name						
Street type	Street direction	PO Box or Route Number				
Municipality (City, Town, etc.)						
Province/State	Postal/ZIP code					
This insurer certifies that the following policies of insurance are at present in force covering all operations of the Insured, in connection with the contract made between the named insured and Her Majesty the Queen in right of Canada, represented by the Minister of Agriculture and Agri-Food Canada.						
POLICY						
Scope of Policy	Number	Inception Date	Expiry Date	Limit of Liability		
				Per Occurrence	General Aggregate Limit	Products / Completed Operations Aggregate Limit
Commercial General Liability						
Builder's Risk "All Risks"/ Installation Floater "All Risks"						
Automobile Insurance				(not less than \$1,000,000.00 inclusive per occurrence)		
Other (list)						
Each of these policies includes the coverages and provisions as specified in Insurance Terms and each policy has been endorsed to cover Her Majesty as an Additional Insured. The Insurer agrees to notify Her Majesty and the Named insured in writing thirty (30) days prior to any material change in, or cancellation of any policy or coverage.						
Name of Insurer's Officer or Authorized Employee			Telephone number		Ext.	
Signature			Date			

## LABOUR AND MATERIAL PAYMENT BOND

BOND NUMBER: \_\_\_\_\_

AMOUNT: \_\_\_\_\_

KNOW ALL PERSONS BY THESE PRESENTS, that \_\_\_\_\_ as Principal,  
hereinafter called the Principal, and \_\_\_\_\_ as Surety,

hereinafter called the Surety, are, subject to the conditions hereinafter contained, held and firmly bound unto Her Majesty the Queen in right of Canada as represented by the Minister of Agriculture and Agri-Food, as Obligee, hereinafter called the Crown, in the amount of

\_\_\_\_\_ dollars (\$ \_\_\_\_\_), lawful money of Canada, for the payment of which sum, well and truly to be made, the Principal and the Surety bind themselves, their heirs, executors, administrators, successors and assigns, jointly and severally, firmly by these presents.

SIGNED AND SEALED this \_\_\_\_\_ day of \_\_\_\_\_, 20\_\_

WHEREAS, the Principal has entered into a Contract with the Crown dated the \_\_\_\_\_ day of \_\_\_\_\_, 20\_\_,  
for \_\_\_\_\_

which contract is by reference made a part hereof, and is hereinafter referred to as the Contract.

NOW, THEREFORE, THE CONDITIONS OF THIS OBLIGATION are such that, if payment is promptly made to all Claimants who have performed labour or services or supplied material in connection with the Contract and any and all duly authorized modifications and extensions of the Contract that may hereafter be made, notice of which modifications and extensions to the Surety being hereby waived, then this obligation shall be void; otherwise it shall remain in full force and effect, subject, however, to the following conditions:

1. For the purpose of this bond, a Claimant is defined as one having a direct contract with the Principal or any Sub-Contractor of the Principal for labour, material or both, used or reasonably required for use in the performance of the Contract, labour and material being construed to include that part of water, gas, power, light, heat, oil, gasoline, telephone services or rental of equipment (but excluding rental of equipment where the rent pursuant to an agreement is to be applied towards the purchase price thereof) directly applicable to the Contract.
2. For the purpose of this Bond, no payment is required to be made in respect of a claim for payment for labour or services performed or material supplied in connection with the Contract that represents a capital expenditure, overhead or general administration costs incurred by the Principal during the currency or in respect of the Contract.
3. The Principal and the Surety hereby jointly and severally agree with the Crown that if any Claimant has not been paid as provided for under the terms of his contract with the Principal or a Sub-Contractor of the Principal before the expiration of a period of ninety (90) days after the date on which the last of such Claimant's labour or service was done or performed or materials were supplied by such Claimant, the Crown may sue on this bond, have the right to prosecute the suit to final judgment for such sum or sums as may be due and have execution thereon; and such right of the Crown is assigned by virtue of Part VIII of the *Financial Administration Act* to such Claimant.
4. For the purpose of this bond the liability of the Surety and the Principal to make payment to any claimant not having a contract directly with the Principal shall be limited to that amount which the Principal would have been obliged to pay to such claimant had the provisions of the applicable provincial or territorial legislation on lien or privileges been applicable to the work. A claimant need not comply with provisions of such legislation setting out steps by way of notice, registration or otherwise as might have been necessary to preserve or perfect any claim for lien or privilege which the claimant might have had. Any such claimant shall be entitled to pursue a claim and to recover judgment hereunder subject to the terms and notification provisions of the Bond.
5. Any material change in the Contract between the Principal and the Crown shall not prejudice the rights or interest of any Claimant under this Bond who is not instrumental in bringing about or has not caused such change.

6. No suit or action shall be commenced hereunder by any Claimant:

- (a) Unless such Claimant shall have given written notice within the time limits hereinafter set forth to the Principal and the Surety above named, stating with substantial accuracy the amount claimed. Such notice shall be served by mailing the same by registered mail to the Principal and the Surety at any place where an office is regularly maintained for the transaction of business by such persons or served in any manner in which legal process may be served in the Province or other part of Canada in which the subject matter of the Contract is located. Such notice shall be given
  - (i) in respect of any claim for the amount or any portion thereof required to be held back from the Claimant by the Principal or by the Sub-Contractor of the Principal under either the terms of the Claimant's Contract with the Principal or the Claimant's Contract with the Sub-Contractor of the Principal within one hundred and twenty (120) days after such Claimant should have been paid in full under this Contract;
  - (ii) in respect of any claim other than for the holdback or portion thereof referred to above within one hundred and twenty (120) days after the date upon which such Claimant did or performed the last of the service, work or labour or furnished the last of the materials for which such claim is made under the Claimant's Contract with the Principal or a Sub-Contractor of the Principal;
- (b) After the expiration of one (1) year following the date on which the Principal ceased work on the said Contract, including work performed under the guarantees provided in the Contract;
- (c) Other than in a court of competent jurisdiction in the province or district of Canada in which the subject matter of the Contract or any part thereof is situated and not elsewhere, and the parties hereto hereby agree to submit to the jurisdiction of such court.

7. The amount of this bond shall be reduced by and to the extent of any payment or payments made in good faith hereunder.

8. The Surety shall not be entitled to claim any moneys relating to the Contract and the liability of the Surety under this Bond shall remain unchanged and, without restricting the generality of the foregoing, the Surety shall pay all valid claims of Claimants under this Bond before any moneys relating to the Contract held by the Crown are paid to the Surety by the Crown.

9. The Surety shall not be liable for a greater sum than the amount specified in this bond.

IN TESTIMONY WHEREOF, the Principal has hereto set its hand and affixed its seal, and the Surety has caused these presents to be sealed with its corporate seal duly attested by the signature of its authorized signing authority, the day and year first above written.

SIGNED, SEALED AND DELIVERED in the presence of:

\_\_\_\_\_  
Principal

\_\_\_\_\_  
Witness

\_\_\_\_\_  
Surety

Note: Affix Corporate seal if applicable.

## PERFORMANCE BOND

**BOND NUMBER:** \_\_\_\_\_

**AMOUNT:** \_\_\_\_\_

KNOW ALL PERSONS BY THESE PRESENTS, that \_\_\_\_\_ as Principal,  
hereinafter called the Principal, and \_\_\_\_\_ as Surety,

hereinafter called the Surety, are, subject to the conditions hereinafter contained, held and firmly bound unto Her Majesty the Queen in right of Canada as represented by the Minister of Agriculture and Agri-Food, as Obligee, hereinafter called the Crown, in the amount of

\_\_\_\_\_ dollars (\$ \_\_\_\_\_), lawful money of Canada, for the payment of which sum, well and truly to be made, the Principal and the Surety bind themselves, their heirs, executors, administrators, successors and assigns, jointly and severally, firmly by these presents.

SIGNED AND SEALED this \_\_\_\_\_ day of \_\_\_\_\_, 20\_\_.

WHEREAS, the Principal entered into a Contract with the Crown dated the \_\_\_\_\_ day of \_\_\_\_\_, 20\_\_,  
for \_\_\_\_\_

which Contract is by reference made a part hereof, and is hereinafter referred to as the Contract.

NOW, THEREFORE, THE CONDITIONS OF THIS OBLIGATION are such that, if the Principal shall well and faithfully observe and perform all the obligations on the part of the Principal to be observed and performed in connection with the Contract, then this obligation shall be void, otherwise it shall remain in full force and effect, subject, however, to the following conditions:

1. Whenever the Principal shall be, and declared by the Crown to be, in default under the Contract, the Surety shall:
  - (a) if the work is not taken out of the Principal's hands, remedy the default of the Principal,
  - (b) if the work is taken out of the Principal's hands and the Crown directs the Surety to undertake the completion of the work, complete the work in accordance with the Contract provided that if a contract is entered into for the completion of the work,
    - (i) it shall be between the Surety and the completing contractor, and
    - (ii) the selection of such completing contractor shall be subject to the approval of the Crown,
  - (c) if the work is taken out of the Principal's hands and the Crown, after reasonable notice to the Surety, does not direct the Surety to undertake the completion of the work, assume the financial responsibility for the cost of completion in excess of the moneys available to the Crown under the Contract,
  - (d) be liable for and pay all the excess costs of completion of the Contract, and
  - (e) not be entitled to any Contract moneys earned by the Principal, up to the date of his default on the Contract and any holdbacks relating to such earned Contract moneys held by the Crown, and the liability of the Surety under this Bond shall remain unchanged provided, however, and without restricting the generality of the foregoing, upon the completion of the Contract to the satisfaction of the Crown, any Contract moneys earned by the Principal or holdbacks related thereto held by the Crown may be paid to the Surety by the Crown.
2. The Surety shall not be liable for a greater sum than the amount specified in this Bond.
3. No suit or action shall be instituted by the Crown herein against the Surety pursuant to these presents after the expiration of two (2) years from the date on which final payment under the Contract is payable.

IN TESTIMONY WHEREOF, the Principal has hereto set its hand and affixed its seal, and the Surety has caused these presents to be sealed with its corporate seal duly attested by the signature of its authorized signing authority, the day and year first above written.

SIGNED, SEALED AND DELIVERED in the presence of:

\_\_\_\_\_  
Principal

\_\_\_\_\_  
Witness

\_\_\_\_\_  
Surety

Note: Affix Corporate seal if applicable.



T4-A CERTIFICATION

The Contractor shall complete and submit this T4-A Certification within fourteen (14) calendar days of Notification of Contract award and within fourteen (14) calendar days immediately following any change to the information already provided under the Contract. Failure to provide this information or failure to provide the correct information shall result in a fundamental breach of the Contract.

1. The Contractor shall enter a [ x ] in one of the boxes below opposite the description that best describes its status.

- [ ] A business incorporated either federally or provincially;
[ ] An unincorporated business, either as a sole proprietor or a partnership; or
[ ] An individual.

Note: The information provided in Section 2 must correspond with that provided in Section 1.

Corporate or unincorporated business or individual's name: \_\_\_\_\_

Street Name or Box #: \_\_\_\_\_

City, Town or Village: \_\_\_\_\_

Province: \_\_\_\_\_

Postal Code: \_\_\_\_\_

2. Contractor shall complete Section 2(a) or 2(b) or 2(c), whichever is applicable to its situation.

(a) If incorporated:

Business Number (BN): \_\_\_\_\_, or
GST / HST Number: \_\_\_\_\_, or
T2 Corporation Tax Number (T2N): \_\_\_\_\_, whichever is applicable

(b) If unincorporated:

Social Insurance Number (SIN): \_\_\_\_\_, and
Business Number (BN): \_\_\_\_\_, or
GST / HST Number: \_\_\_\_\_, whichever is applicable

Note: The Unincorporated Business Name must be the same as the name associated with the Revenue Canada Business Number or the GST Number.

(c) If individual:

Social Insurance Number (SIN): \_\_\_\_\_, and
Business Number (BN): \_\_\_\_\_, or
GST / HST Number: \_\_\_\_\_, whichever is applicable

Note: The Individual's Name must be the same as the name associated with the Social Insurance Number.

3. WE HEREBY CERTIFY that I/We have examined the information provided above, including the legal name, address and Revenue Canada identifier (SIN, BN, GST / HST No., T2N), as applicable, and that it is correct and complete, and fully discloses my/our identification.

Contractor's signature Title of Signatory Date