



National Defence  
National Defence Headquarters  
Ottawa, Ontario  
K1A 0K2

Défense nationale  
Quartier général de la Défense nationale  
Ottawa (Ontario)  
K1A 0K2

## REQUEST FOR PROPOSAL DEMANDE DE PROPOSITION

### RETURN BIDS TO: RETOURNER LES SOUMISSIONS À :

Bid Receiving – PWGSC / Réception des  
soumissions - TPSGC

tpsgc.dgareceptiondessoumissions-  
abbidreceiving.pwgsc@tpsgc-pwgsc.gc.ca

Via ePost \ Postel  
Bid Fax: (819) 997-9776

### Proposal To: National Defence Canada

We hereby offer to sell to Her Majesty the Queen in right of Canada, in accordance with the terms and conditions set out herein, referred to herein or attached hereto, the goods and services listed herein and on any attached sheets at the price(s) set out therefore.

### Proposition à : Défense nationale Canada

Nous offrons par la présente de vendre à Sa Majesté la Reine du chef du Canada, aux conditions énoncées ou incluses par référence dans la présente et aux annexes ci-jointes, les biens et services énumérés ici et sur toute feuille ci-annexée, au(x) prix indique(s).

### Solicitation Closes – L'invitation prend fin

At – à : 14 :00 EST

On - le : January 25, 2020

<b>Title/Titre</b> NSN: 4030-21-890-0167, HOOK ASSEMBLY, PELICAN	<b>Solicitation No – N° de l'invitation</b> <b>W8482-218501/A</b>
<b>Date of Solicitation – Date de l'invitation</b> December 23, 2020	
<b>Address Enquiries to – Adresser toutes questions à</b>  <b>Chelsea Fowler</b> <b>D Mar P 4-3-3-2</b> <b>chelsea.fowler@forces.gc.ca</b>	
<b>Telephone No. – N° de téléphone</b>	<b>FAX No – N° de fax</b>
<b>Destination</b> See herein	

### Instructions:

**Municipal taxes are not applicable. Unless otherwise specified herein all prices quoted must include all applicable Canadian customs duties, GST/HST, excise taxes and are to be delivered Delivery Duty Paid including all delivery charges to destination(s) as indicated. The amount of the Goods and Services Tax/Harmonized Sales Tax is to be shown as a separate item.**

**Instructions: Les taxes municipales ne s'appliquent pas. Sauf indication contraire, les prix indiqués doivent comprendre les droits de douane canadiens, la TPS/TVH et la taxe d'accise. Les biens doivent être livrés « rendu droits acquittés », tous frais de livraison compris, à la ou aux destinations indiquées. Le montant de la taxe sur les produits et services/taxe de vente harmonisée doit être indiqué séparément.**

Delivery required - Livraison exigée	Delivery offered - Livraison proposée
Vendor Name and Address - Raison sociale et adresse du fournisseur	
Name and title of person authorized to sign on behalf of vendor (type or print) - Nom et titre de la personne autorisée à signer au nom du fournisseur (caractère d'imprimerie)	
Name/Nom _____	Title/Titre _____
Signature _____	Date _____

---

## TABLE OF CONTENTS

<b>PART 1 - GENERAL INFORMATION</b>	<b>4</b>
1.1 SECURITY REQUIREMENTS	4
1.2 REQUIREMENT	4
1.3 DEBRIEFINGS	4
1.4 TRADE AGREEMENTS	4
1.5 CANADIAN CONTENT	4
1.6 EPOST CONNECT SERVICE	4
<b>PART 2 - BIDDER INSTRUCTIONS</b>	<b>4</b>
2.1 STANDARD INSTRUCTIONS, CLAUSES AND CONDITIONS	4
2.2 SUBMISSION OF BIDS	4
2.3 ENQUIRIES - BID SOLICITATION	5
2.4 APPLICABLE LAWS	5
2.5 BID CHALLENGE AND RECOURSE MECHANISMS	5
<b>PART 3 - BID PREPARATION INSTRUCTIONS</b>	<b>6</b>
3.1 BID PREPARATION INSTRUCTIONS	6
<b>PART 4 - EVALUATION PROCEDURES AND BASIS OF SELECTION</b>	<b>7</b>
4.1 EVALUATION PROCEDURES	7
4.2 BASIS OF SELECTION	9
<b>PART 5 - CERTIFICATIONS AND ADDITIONAL INFORMATION</b>	<b>9</b>
5.1 CERTIFICATIONS REQUIRED WITH THE BID	9
5.2 CERTIFICATIONS PRECEDENT TO CONTRACT AWARD AND ADDITIONAL INFORMATION	10
<b>PART 6 - RESULTING CONTRACT CLAUSES</b>	<b>10</b>
6.1 SECURITY REQUIREMENTS	10
6.2 REQUIREMENT	10
6.3 STANDARD CLAUSES AND CONDITIONS	11
6.4 TERM OF CONTRACT	11
6.5 AUTHORITIES	11
6.6 PAYMENT	12
6.7 INVOICING INSTRUCTIONS	13
6.8 CERTIFICATIONS AND ADDITIONAL INFORMATION	13
6.9 APPLICABLE LAWS	13
6.10 PRIORITY OF DOCUMENTS	13
6.11 DEFENCE CONTRACT	14
6.12 CONDITION OF MATERIAL - CONTRACT	14
6.13 SACC MANUAL CLAUSES	14
6.14 ASBESTOS	14
6.15 PACKAGING	14
6.16 QUALITY ASSURANCE	15
6.17 SHIPPING INSTRUCTIONS (DEPARTMENT OF NATIONAL DEFENCE)	15
6.18 DISPUTE RESOLUTION	18
6.19 EQUIVALENCY OF EQUIPMENT	19
<b>ANNEX "A" - LINE ITEM DETAILS</b>	<b>21</b>
<b>APPENDIX 1 TO ANNEX A - DELIVERY AND INVOICE CODES</b>	<b>22</b>

Solicitation No. - N° de l'invitation

W8482-218501/A

Client Ref. No. - N° de réf. du client

XXXXX-XXXXXX

Amd. No. - N° de la modif.

File No. - N° du dossier

xxxxx.XXXXX-XXXXXX

Buyer ID - Id de l'acheteur

25H

CCC No./N° CCC - FMS No./N° VME

---

**ANNEX "B" - BASIS OF PAYMENT.....23**

**ANNEX "C" - LONG TEXT DESCRIPTION.....25**

**ANNEX "D" TO PART 3 OF THE BID SOLICITATION - ELECTRONIC PAYMENT INSTRUMENTS.....27**

## **PART 1 - GENERAL INFORMATION**

### **1.1 Security Requirements**

There is no security requirement applicable to the Contract.

### **1.2 Requirement**

The requirement is detailed in Annex "A", Line Item Details.

### **1.3 Debriefings**

Bidders may request a debriefing on the results of the bid solicitation process. Bidders should make the request to the Contracting Authority within 15 working days from receipt of the results of the bid solicitation process. The debriefing may be in writing, by telephone or in person.

### **1.4 Trade Agreements**

The requirement is subject to the provisions of the following trade agreements: Canadian Free Trade Agreement.

### **1.5 Canadian Content**

The requirement is subject to a preference for Canadian goods.

### **1.6 epost Connect service**

This bid solicitation allows bidders to use the epost Connect service provided by Canada Post Corporation to transmit their bid electronically. Bidders must refer to Part 2 entitled Bidder Instructions, and Part 3 entitled Bid Preparation Instructions, of the bid solicitation, for further information.

## **PART 2 - BIDDER INSTRUCTIONS**

### **2.1 Standard Instructions, Clauses and Conditions**

All instructions, clauses and conditions identified in the bid solicitation by number, date and title are set out in the [Standard Acquisition Clauses and Conditions Manual](https://buyandsell.gc.ca/policy-and-guidelines/standard-acquisition-clauses-and-conditions-manual) (https://buyandsell.gc.ca/policy-and-guidelines/standard-acquisition-clauses-and-conditions-manual) issued by Public Works and Government Services Canada.

Bidders who submit a bid agree to be bound by the instructions, clauses and conditions of the bid solicitation and accept the clauses and conditions of the resulting contract.

The [2003](#) (2020-05-28) Standard Instructions - Goods or Services - Competitive Requirements, are incorporated by reference into and form part of the bid solicitation, with the following modification:

- a. Section 02, Procurement Business Number is deleted in its entirety.

#### **2.1.1 SACC Manual Clauses**

[B1000T](#) (2014-06-26), Condition of Material – Bid

### **2.2 Submission of Bids**

---

Bids must be submitted only to Public Works and Government Services Canada (PWGSC) Bid Receiving Unit by the date, time and place indicated on page 1 in the bid solicitation.

Note: For bidders choosing to submit using epost Connect for bids closing at the Bid Receiving Unit in the National Capital Region (NCR) the email address is:

tpsgc.dgareceptiondessoumissions-abbidreceiving.pwgsc@tpsgc-pwgsc.gc.ca

Note: Bids will not be accepted if emailed directly to this email address. This email address is to be used to open an epost Connect conversation, as detailed in Standard Instructions 2003, or to send bids through an epost Connect message if the bidder is using its own licensing agreement for epost Connect.

### 2.3 Enquiries - Bid Solicitation

All enquiries must be submitted in writing to the Contracting Authority no later than 7 calendar days before the bid closing date. Enquiries received after that time may not be answered.

Bidders should reference as accurately as possible the numbered item of the bid solicitation to which the enquiry relates. Care should be taken by Bidders to explain each question in sufficient detail in order to enable Canada to provide an accurate answer. Technical enquiries that are of a proprietary nature must be clearly marked "proprietary" at each relevant item. Items identified as "proprietary" will be treated as such except where Canada determines that the enquiry is not of a proprietary nature. Canada may edit the question(s) or may request that the Bidder do so, so that the proprietary nature of the question(s) is eliminated, and the enquiry can be answered to all Bidders. Enquiries not submitted in a form that can be distributed to all Bidders may not be answered by Canada.

### 2.4 Applicable Laws

Any resulting contract must be interpreted and governed, and the relations between the parties determined, by the laws in force in Ontario.

Bidders may, at their discretion, substitute the applicable laws of a Canadian province or territory of their choice without affecting the validity of their bid, by deleting the name of the Canadian province or territory specified and inserting the name of the Canadian province or territory of their choice. If no change is made, it acknowledges that the applicable laws specified are acceptable to the Bidders.

### 2.5 Bid Challenge and Recourse Mechanisms

- (a) Several mechanisms are available to potential suppliers to challenge aspects of the procurement process up to and including contract award.
- (b) Canada encourages suppliers to first bring their concerns to the attention of the Contracting Authority. Canada's [Buy and Sell](#) website, under the heading "[Bid Challenge and Recourse Mechanisms](#)" contains information on potential complaint bodies such as:
  - Office of the Procurement Ombudsman (OPO)
  - Canadian International Trade Tribunal (CITT)
- (c) Suppliers should note that there are **strict deadlines** for filing complaints, and the time periods vary depending on the complaint body in question. Suppliers should therefore act quickly when they want to challenge any aspect of the procurement process.

---

## PART 3 - BID PREPARATION INSTRUCTIONS

### 3.1 Bid Preparation Instructions

If the Bidder chooses to submit its bid electronically, Canada requests that the Bidder submits its bid in accordance with section 08 of the 2003 standard instructions. The epost Connect system has a limit of 1GB per single message posted and a limit of 20GB per conversation.

The bid must be gathered per section and separated as follows:

Section I: Technical Bid  
Section II: Financial Bid  
Section III: Certifications  
Section IV: Additional Information

If the Bidder is simultaneously providing copies of its bid using multiple acceptable delivery methods, and if there is a discrepancy between the wording of any of these copies and the electronic copy provided through epost Connect service, the wording of the electronic copy provided through epost Connect service will have priority over the wording of the other copies.

Prices must appear in the financial bid only. No prices must be indicated in any other section of the bid.

#### Section I: Technical Bid

In their technical bid, Bidders should explain and demonstrate how they propose to meet the requirements and how they will carry out the Work.

#### Section II: Financial Bid

Bidders must submit their financial bid in accordance with the Basis of Payment.

#### Section III: Certifications

Bidders must submit the certifications and additional information required under Part 5.

##### 3.1.1 Electronic Payment of Invoices – Bid

If you are willing to accept payment of invoices by Electronic Payment Instruments, complete Annex “D” Electronic Payment Instruments, to identify which ones are accepted.

If Annex “D” Electronic Payment Instruments is not completed, it will be considered as if Electronic Payment Instruments are not being accepted for payment of invoices.

Acceptance of Electronic Payment Instruments will not be considered as an evaluation criterion.

##### 3.1.2 Exchange Rate Fluctuation

1. The Bidder may request Canada to assume the risks and benefits of exchange rate fluctuations. If the Bidder claims for an exchange rate adjustment, this request must be clearly indicated in the bid at time of bidding. The Bidder must submit form [PWGSC-TPSGC 450](#), Claim for Exchange Rate Adjustments with its bid, indicating the Foreign Currency Component (FCC) in Canadian dollars for each line item for which an exchange rate adjustment is required.
2. The FCC is defined as the portion of the price or rate that will be directly affected by exchange rate fluctuations. The FCC should include all related taxes, duties and other costs paid by the Bidder and which are to be included in the adjustment amount.

3. The total price paid by Canada on each invoice will be adjusted at the time of payment, based on the FCC and the exchange rate fluctuation provision in the contract. The exchange rate adjustment will only be applied where the exchange rate fluctuation is greater than 2% (increase or decrease).
4. At time of bidding, the Bidder must complete columns (1) to (4) on form [PWGSC-TPSGC 450](#) , for each line item where they want to invoke the exchange rate fluctuation provision. Where bids are evaluated in Canadian dollars, the dollar values provided in column (3) should also be in Canadian dollars, so that the adjustment amount is in the same currency as the payment.
5. Alternate rates or calculations proposed by the Bidder will not be accepted for the purposes of this exchange rate fluctuation provision.

## **PART 4 - EVALUATION PROCEDURES AND BASIS OF SELECTION**

### **4.1 Evaluation Procedures**

- (a) Bids will be assessed in accordance with the entire requirement of the bid solicitation including the technical and financial evaluation criteria.
- (b) An evaluation team composed of representatives of Canada will evaluate the bids.
- (c) The evaluation team will determine if there are two (2) or more bids with a valid Canadian content certification with the bids coming from two or more Bidders that are not affiliated within the meaning used in the Competition Act, R.S.C., 1985, c. C-34. In that event, only those bids with a valid certification will be eligible to be awarded a contract; otherwise, all bids will be eligible. If at any point in the evaluation process it is found, whether by determination of invalidity of certifications, determination that bids are non-responsive or withdrawal of bids by Bidders, that there are no longer two (2) or more responsive bids with a valid certification, then all responsive bids will be eligible to be awarded a contract. Canada may conduct the validation of Canadian content certifications at any time in the evaluation process including doing so concurrently with other steps.

#### **4.1.1 Technical Evaluation**

##### **4.1.1.1 Mandatory Technical Criteria**

- a) Bidders must indicate the Part Number and the NSCM/NCAGE they are offering.
- b) Bidders proposing an Equivalent or Substitute Product must indicate the brand name and model and/or Part Number and the NSCN/NCAGE they are offering.

##### **4.1.1.2 Equivalent Products - Bid**

- a) This bid solicitation includes requirements to propose equipment (each, a Line Item) that has been specified by brand name, NATO Stock Number (NSN), and/or part number in order to ensure compatibility, interoperability and interchangeability with existing equipment owned by Canada.
- b) Where equipment has been described in this bid solicitation by NSN and/or part number, and more than one part number is listed as associated with a single NSN Line Item, equivalency will be assessed against the first part number listed under the NSN. Other part numbers listed under that NSN will be considered to meet the requirement without requiring an assessment as an equivalent product, unless this bid solicitation specifies

---

otherwise.

- c) Proposed equipment that is a replacement part number (superseded or obsolete) from the Original Equipment Manufacturer of a part number listed under a Line Item must be assessed as an equivalent product under this Article, in order to be considered to meet the requirement.
- d) Products that are equivalent in form, fit, function and quality that are fully compatible, interchangeable, and interoperable with the existing equipment owned by Canada as identified in the web links associated with each Line Item will be considered where the Bidder:
  - i. clearly designates in its bid the brand name, NATO Stock Number, and/or part number of the proposed equivalent product;
  - ii. provides complete specifications and descriptive technical documentation for each equivalent item proposed;
  - iii. substantiates the compliance of its proposed equivalent by demonstrating that it meets all mandatory performance criteria that are specified in this bid solicitation;
  - iv. demonstrates that the equipment is fully compatible, interoperates with and is interchangeable with the corresponding Line Item(s) specified in this bid solicitation; and
  - v. clearly identifies those areas in the specifications and descriptive technical documentation that demonstrate the equivalence of the proposed equivalent product.
- e) If requested during evaluation, the Bidder must submit a sample of any proposed equivalent product to the Contracting Authority for testing.
- f) If requested during evaluation, the Bidder must provide a demonstration of its proposed equivalent product.
- g) Proposed equivalent products will be declared non-responsive if:
  - i. the bid fails to provide all the information (including Certifications) required to allow the Contracting Authority to evaluate the equivalency of the proposed equivalent, including additional information requested by the Contracting Authority during the evaluation to supplement the information submitted in the bid (Note: it is the responsibility of the Bidder to include all information required to evaluate equivalency as described above; however, all bidders acknowledge that Canada will have the right, but not the obligation, to request any additional information during the evaluation that it requires to make a determination regarding equivalency);
  - ii. the Contracting Authority determines that the proposed equivalent fails to meet or exceed the mandatory requirements specified in this bid solicitation; or
  - iii. the Contracting Authority determines that the proposed equivalent is not equivalent in form, fit, function or quality to the item(s) specified in this bid solicitation or that the proposed equivalent is not fully compatible, interoperable and interchangeable with the existing equipment owned by Canada.



#### 4.1.2 Financial Evaluation

SACC *Manual* Clause [A0222T](#) (2014-06-26), Evaluation of Price - Canadian / Foreign Bidders

Bidders must submit prices in Canadian dollars. Bids submitted in foreign currency will be rejected.

#### 4.2 Basis of Selection

SACC *Manual* Clause [A0031T](#) (2010-08-16), Mandatory Technical Criteria

### PART 5 – CERTIFICATIONS AND ADDITIONAL INFORMATION

Bidders must provide the required certifications and additional information to be awarded a contract.

The certifications provided by Bidders to Canada are subject to verification by Canada at all times. Unless specified otherwise, Canada will declare a bid non-responsive, or will declare a contractor in default if any certification made by the Bidder is found to be untrue whether made knowingly or unknowingly, during the bid evaluation period or during the contract period.

The Contracting Authority will have the right to ask for additional information to verify the Bidder's certifications. Failure to comply and to cooperate with any request or requirement imposed by the Contracting Authority will render the bid non-responsive or constitute a default under the Contract.

#### 5.1 Certifications Required with the Bid

Bidders must submit the following duly completed certifications as part of their bid.

##### 5.1.1 Integrity Provisions - Declaration of Convicted Offences

In accordance with the Integrity Provisions of the Standard Instructions, all bidders must provide with their bid, **if applicable**, the declaration form available on the [Forms for the Integrity Regime](http://www.tpsgc-pwgsc.gc.ca/ci-if/declaration-eng.html) website (<http://www.tpsgc-pwgsc.gc.ca/ci-if/declaration-eng.html>), to be given further consideration in the procurement process.

##### 5.1.2 Additional Certifications Required with the Bid

###### 5.1.2.1 Canadian Content Certification

This procurement is conditionally limited to Canadian goods.

Subject to the evaluation procedures contained in the bid solicitation, bidders acknowledge that only bids for items with a certification that the item(s) offered are Canadian goods, as defined in clause A3050T, may be considered.

Failure to provide this certification completed with the bid will result in the item(s) offered being treated as non-Canadian goods.

Bidders must clearly identify below which items meet the definition of Canadian good and complete the certification below.

The Bidder certifies that:

( ) the items offered and identified as Canadian goods are Canadian goods as defined in paragraph 1 of clause A3050T.

**5.1.2.1.1** SACC Manual clause [A3050T](#) (2020-07-01) Canadian Content Definition

## **5.2 Certifications Precedent to Contract Award and Additional Information**

The certifications and additional information listed below should be submitted with the bid, but may be submitted afterwards. If any of these required certifications or additional information is not completed and submitted as requested, the Contracting Authority will inform the Bidder of a time frame within which to provide the information. Failure to provide the certifications or the additional information listed below within the time frame provided will render the bid non-responsive.

### **5.2.1 Integrity Provisions – Required Documentation**

In accordance with the section titled Information to be provided when bidding, contracting or entering into a real property agreement of the [Ineligibility and Suspension Policy](http://www.tpsgc-pwgsc.gc.ca/ci-if/politique-policy-eng.html) (<http://www.tpsgc-pwgsc.gc.ca/ci-if/politique-policy-eng.html>), the Bidder must provide the required documentation, as applicable, to be given further consideration in the procurement process.

### **5.2.2 Integrity Provisions - List of Names**

Bidders who are incorporated, including those bidding as a joint venture, must provide a complete list of names of all individuals who are currently directors of the Bidder. Bidders bidding as sole proprietorship, as well as those bidding as a joint venture, must provide the name of the owner(s). Bidders bidding as societies, firms or partnerships do not need to provide a list of names.

### **5.2.3 Federal Contractors Program for Employment Equity - Bid Certification**

By submitting a bid, the Bidder certifies that the Bidder, and any of the Bidder's members if the Bidder is a Joint Venture, is not named on the Federal Contractors Program (FCP) for employment equity "FCP Limited Eligibility to Bid" list available at the bottom of the page of the [Employment and Social Development Canada \(ESDC\) - Labour's](https://www.canada.ca/en/employment-social-development/programs/employment-equity/federal-contractor-program.html#) website (<https://www.canada.ca/en/employment-social-development/programs/employment-equity/federal-contractor-program.html#>).

Canada will have the right to declare a bid non-responsive if the Bidder, or any member of the Bidder if the Bidder is a Joint Venture, appears on the "FCP Limited Eligibility to Bid" list at the time of contract award.

## **PART 6 - RESULTING CONTRACT CLAUSES**

The following clauses and conditions apply to and form part of any contract resulting from the bid solicitation.

### **6.1 Security Requirements**

**6.1.1** There is no security requirement applicable to the Contract.

### **6.2 Requirement**

The Contractor must provide the items detailed under the "Line Item Details" at Annex "A".

---

## 6.3 Standard Clauses and Conditions

All clauses and conditions identified in the Contract by number, date and title are set out in the [Standard Acquisition Clauses and Conditions Manual](https://buyandsell.gc.ca/policy-and-guidelines/standard-acquisition-clauses-and-conditions-manual) (https://buyandsell.gc.ca/policy-and-guidelines/standard-acquisition-clauses-and-conditions-manual) issued by Public Works and Government Services Canada.

### 6.3.1 General Conditions

[2010A](#) (2020-05-28), General Conditions - Goods (Medium Complexity), apply to and form part of the Contract, with the following modifications:

"Canada", "Crown", "Her Majesty" or "the Government" means Her Majesty the Queen in right of Canada as represented by the Minister of National Defence and any other person duly authorized to act on behalf of that minister or, if applicable, an appropriate minister to whom the Minister of National Defence has delegated his or her powers, duties or functions and any other person duly authorized to act on behalf of that minister.

## 6.4 Term of Contract

### 6.4.1 Period of the Contract

The period of the Contract is from date of Contract award to the end of the warranty period as described in Section 09 of [2010A](#) (2020-05-28) General Conditions - Goods (Medium Complexity).

### 6.4.2 Delivery Date

All the deliverables must be received on or before \_\_\_\_\_.

DND reserves the right to negotiate delivery date changes to before or after March 31, 2021.

### 6.4.3 Delivery Points

Delivery of the requirement will be made to delivery point(s) specified at Annex "A" of the Contract.

## 6.5 Authorities

### 6.5.1 Contracting Authority

The Contracting Authority for the Contract is:

Name: Chelsea Fowler  
Title: Materiel Acquisition and Support Officer  
Directorate: D MAR P 4-3-3-2  
Address: 101 Colonel By Drive  
Ottawa, Ontario, K1A 0K2  
E-mail address: Chelsea.fowler@forces.gc.ca

The Contracting Authority is responsible for the management of the Contract and any changes to the Contract must be authorized in writing by the Contracting Authority. The Contractor must not perform work in excess of or outside the scope of the Contract based on verbal or written requests or instructions from anybody other than the Contracting Authority.

### 6.5.2 Technical Authority

---

The Technical Authority for the Contract is:

Name: \_\_\_\_\_

Title: \_\_\_\_\_

Organization: \_\_\_\_\_

Address: \_\_\_\_\_

Telephone: \_\_\_ - \_\_\_ - \_\_\_\_

E-mail: \_\_\_\_\_.

The Technical Authority named above is the representative of the department or agency for whom the Work is being carried out under the Contract and is responsible for all matters concerning the technical content of the Work under the Contract. Technical matters may be discussed with the Technical Authority, however the Technical Authority has no authority to authorize changes to the scope of the Work. Changes to the scope of the Work can only be made through a contract amendment issued by the Contracting Authority.

### 6.5.3 Contractor's Representative

Name: \_\_\_\_\_

Title: \_\_\_\_\_

Address: \_\_\_\_\_

Telephone: \_\_\_ - \_\_\_ - \_\_\_\_

E-mail: \_\_\_\_\_

## 6.6 Payment

### 6.6.1 Basis of Payment

In consideration of the Contractor satisfactorily completing all of its obligations under the Contract, the Contractor will be paid a firm price as specified in Annex "B", Basis of Payment. Customs duties are excluded and Applicable Taxes are extra.

Canada will not pay the Contractor for any design changes, modifications or interpretations of the Work, unless they have been approved, in writing, by the Contracting Authority before their incorporation into the Work.

### 6.6.2 Terms of Payment

SACC Manual clause [H1001C](#) (2008-05-12), Multiple Payments

SACC Manual clause [C3015C](#) (2017-08-17), Exchange rate fluctuation adjustment

SACC Manual clause [C2000C](#) (2007-11-30), Taxes - Foreign-based Contractor

SACC Manual clause [C2608C](#) (2020-07-01), Canadian Customs Documentation

SACC Manual clause [C2605C](#) (2008-05-12), Canadian Customs Duties and Sales Tax - Foreign-based Contractor

SACC Manual clause [C2610C](#) (2007-11-30), Customs Duties – Department of National Defence – Importer

### 6.6.3 Electronic Payment of Invoices – Contract

The Contractor accepts to be paid using any of the following Electronic Payment Instrument(s):

- a) Direct Deposit (Domestic and International);
- b) Electronic Data Interchange (EDI);

c) Wire Transfer (International Only).

## 6.7 Invoicing Instructions

1. The Contractor must submit invoices in accordance with the section entitled "Invoice Submission" of the general conditions. Invoices cannot be submitted until all work identified in the invoice is completed.
2. Invoices must be distributed as follows:
  - a. The original and one copy must be forwarded to the consignee for certification and payment.

Department of National Defence  
Maritime Forces Atlantic  
Accts Payable Bldg. S-90, Room 334  
2686 Sextant Lane, Stadacona  
PO Box 99000 Stn Forces  
Halifax, NS B3K 5X5  
Canada  
hfxaccountspayable@forces.gc.ca

and

Department of National Defence  
Base Logistics Officer  
CFB Esquimalt  
STN Forces, P.O. Box 17000  
Victoria, BC V9A 7N2  
Canada  
ESQBLOGAcctsPayable@forces.gc.ca

- b. One copy must be forwarded to:

Department of National Defence  
101 Colonel By Drive  
Ottawa, Ontario K1A 0K2  
Attention: D Mar P 4-3-3-2

## 6.8 Certifications and Additional Information

### 6.8.1 Compliance

Unless specified otherwise, the continuous compliance with the certifications provided by the Contractor in its bid or precedent to contract award, and the ongoing cooperation in providing additional information are conditions of the Contract and failure to comply will constitute the Contractor in default. Certifications are subject to verification by Canada during the entire period of the Contract.

### 6.9 Applicable Laws

The Contract must be interpreted and governed, and the relations between the parties determined, by the laws in force in Ontario.

### 6.10 Priority of Documents

---

If there is a discrepancy between the wording of any documents that appear on the list, the wording of the document that first appears on the list has priority over the wording of any document that subsequently appears on the list.

- a) The Articles of Agreement;
- b) The general conditions [2010A](#) (2020-05-28), General Conditions - Goods (Medium Complexity);
- c) Annex A, Line Item Details;
- d) Annex B, Basis of Payment;
- e) Annex C, Long Text Description
- f) The Contractor's bid dated \_\_\_\_\_.

#### **6.11 Defence Contract**

SACC *Manual* clause [A9006C](#) (2012-07-16), Defence Contract

#### **6.12 Condition of Material - Contract**

The Contractor must provide material that is new production of current manufacture supplied by the principal manufacturer or its accredited agent. The material must conform to the latest issue of the applicable drawing, specification and part number, as applicable, that was in effect on the bid closing date.

#### **6.13 SACC *Manual* Clauses**

[B7500C](#) (2006-06-16), Excess Goods

[D2001C](#) (2007-11-30), Labelling

[D2000C](#) (2007-11-30), Marking

[D2025C](#) (2017-08-17), Wood Packaging Materials

[D6010C](#) (2007-11-30), Palletization

[D9002C](#) (2007-11-30), Incomplete Assemblies

[G1005C](#) (2016-01-28), Insurance - No Specific Requirement

[C2800C](#) (2013-01-28), Priority Rating

[C2801C](#) (2017-08-17), Priority Rating: Canadian-based contractors

#### **6.14 Asbestos**

The contractor shall not use asbestos in the equipment unless no feasible alternative is available, in which case rationale shall be provided. Any parts containing asbestos shall be properly labelled, and the part number and location be explicitly identified in technical documentations.

#### **6.15 Packaging**

##### **6.15.1 Packaging Requirement using Specification D-LM-008-036/SF-000**

The Contractor must prepare item numbers 001 to 002 for delivery in accordance with the latest issue of the Canadian Forces Packaging Specification **D-LM-008-036/SF-000**, DND Minimum Requirements for Manufacturer's Standard Pack.

The Contractor must package item numbers 001 to 002 in quantities of 1 (EA) by package.

## 6.16 Quality Assurance

D5540C (2019-05-30) ISO 9001:2015 Quality Management Systems - Requirements (Quality Assurance Code Q)

D5510C (2017-08-17) Quality Assurance Authority (DND) - Canadian-based Contractor

OR

D5515C (2010-01-11) Quality Assurance Authority (Department of National Defence) - Foreign-based and United States Contractor

D5606C (2017-11-28) Release Documents (DND) - Canadian-based Contractor

OR

D5604C (2008-12-12) Release Documents (Department of National Defence) - Foreign-based Contractor

OR

D5605C (2010-01-11) Release Document (Department of National Defence) - United States-based Contractor

A1009C (2008-05-12) Work Site Access

D5620C (2012-07-16) Release Documents – Distribution

The Contractor must prepare the release documents in a current electronic format and distribute them as follows:

- a) One (1) copy mailed to consignee marked: "Attention: Receipts Officer";
- b) Two (2) copies with shipment (in a waterproof envelope) to the consignee;
- c) One (1) copy to the Contracting Authority;
- d) One (1) copy to:

National Defence Headquarters  
MGen George R. Pearkes Building  
101 Colonel By Drive  
Ottawa, ON K1A OK2  
Attention: A/D Mar P 4-3-4

- e) One (1) copy to the Quality Assurance Representative;
- f) One (1) copy to the Contractor; and
- g) For all non-Canadian contractors, one (1) copy to:

DQA/Contract Administration  
National Defence Headquarters  
Mgen George R. Pearkes Building  
101 Colonel By Drive  
Ottawa, ON K1A OK2  
E-mail: [ContractAdmin.DQA@forces.gc.ca](mailto:ContractAdmin.DQA@forces.gc.ca).

## 6.17 Shipping Instructions (Department of National Defence)

### 6.17.1 Shipping Instructions (Department of National Defence) - Canadian-based Contractor

1. Delivery will be FCA Free Carrier at \_\_\_\_\_ Incoterms 2000. The Contractor must load the goods onto the carrier designated by the Department of National Defence (DND). Onward shipment from the delivery point to the consignee will be Canada's responsibility.
2. Before shipping the goods, the Contractor must contact the following DND Inbound Logistics Coordination Center by facsimile or e-mail, to arrange for shipment, and provide the information detailed at paragraph 3.
  - a. Inbound Logistics Co-ordination Center (ILCC)  
Telephone: 1-877-877-7423 (toll free)  
Facsimile: 1-877-877-7409 (toll free)  
E-mail: [ILHQOttawa@forces.gc.ca](mailto:ILHQOttawa@forces.gc.ca)
3. The Contractor must provide the following information to the DND Inbound Logistics Coordination Center when arranging for shipment:
  - a. the Contract number;
  - b. consignee address (for multiple addresses, items must be packaged and labelled separately with each consignee address);
  - c. description of each item;
  - d. the number of pieces and type of packaging (i.e., carton, crate, drum, skid);
  - e. actual weight and dimensions of each piece type, including gross weight;
  - f. full details of dangerous goods/hazardous products, as required for the applicable mode of transportation, signed certificates for dangerous goods/hazardous products as required for shipment by the International Maritime Dangerous Goods Code, the International Air Transport Association regulations or the applicable Canadian [Transportation of Dangerous Goods Regulations](#), and a copy of the safety data sheet in English and French.
4. Following receipt of this information by Canada, Canada will provide the appropriate shipping instructions, which may include the requirement for specific consignee address labelling, and the marking of each piece with a Transportation Control Number.
5. The Contractor must not ship the goods before receiving shipping instructions from the DND Inbound Logistics contact.
6. If the Contractor delivers the goods at a place and time which are not in accordance with the given delivery instructions or fail to fulfill reasonable delivery instructions given by Canada, the Contractor must reimburse Canada any additional expenses and costs incurred.
7. If Canada is responsible for delays in delivering the goods, ownership and risk will be transferred to Canada upon expiry of either 30 days following the date on which a duly completed shipping application is received by Canada or by its appointed forwarding agent, or 30 days following the delivery date specified in the Contract, whichever is later.

#### **6.17.1 Shipping Instructions (Department of National Defence) - Foreign-based Contractors**

1. Delivery will be FCA Free Carrier at \_\_\_\_\_ Incoterms 2000. The Contractor must load the goods onto the carrier designated by the Department of National Defence (DND). Onward shipment from the delivery point to the consignee will be Canada's responsibility



- 
2. Before shipping the goods, the Contractor must contact the following DND Inbound Logistics Coordination Center by facsimile or e-mail, to arrange for shipment, and provide the information detailed at paragraph 3.
- a. Insert the following when the Contractor is located in the United States (U.S.):  
Inbound Logistics Coordination Center (ILCC):  
Telephone: 1-877-447-7701 (toll free)  
Facsimile: 1-877-877-7409 (toll free)  
E-mail: [ILHQOttawa@forces.gc.ca](mailto:ILHQOttawa@forces.gc.ca)  
OR
- b. Insert the following when the Contractor is located in United Kingdom (UK) and Ireland:  
Inbound Logistics United Kingdom (ILUK):  
Telephone: 011-44-1895-613023, or 011-44-1895-613024, or  
Facsimile: 011-44-1895-613046  
E-mail: [CFSUEDetUKMovements@forces.gc.ca](mailto:CFSUEDetUKMovements@forces.gc.ca)  
In addition, the Contractor must send to ILUK the completed form "Shipping Advice and Export Certificate" by e-mail to: [CFSUEDetUKMovements@forces.gc.ca](mailto:CFSUEDetUKMovements@forces.gc.ca).  
The shipment of any items above the value of 600 GBP (pound sterling) being exported from the United Kingdom and Ireland will be cleared by DND using Her Majesty's Customs & Excise (HMCE) New Export Systems (NES). The Contractor must comply with HMCE requirements by registering with HMCE or by having a freight forwarder complete the entry. A printed copy of the NES entry Export Declaration clearly displaying the Declaration Unique Consignment Reference Number must be provided by the Contractor and attached to the consignment. The Contractor must ensure that this procedure is carried out for all stores whether they be initial purchase or repair and overhaul export items. HMCE will authorize Canadian Forces Support Unit (Europe) to ship the goods only if the procedure has been adhered to completely and properly by the Contractor. **Note:** To ensure you receive a reply on any contracting information such as Incoterms etc, always include the e-mail address: [ILHQcontract-ILHQcontrat@forces.gc.ca](mailto:ILHQcontract-ILHQcontrat@forces.gc.ca) in carbon copy (cc).  
OR
- c. Insert the following when the Contractor is located in a country other than Canada, the U.S., the UK and Ireland:  
Inbound Logistics Europe Area (ILEA):  
Telephone: +49-(0)-2203-908-1807 or 2748 or 5304  
Facsimile: +49-(0)-2203-908-2746  
Email: [ILEA@forces.gc.ca](mailto:ILEA@forces.gc.ca)  
**Note:** To ensure you receive a reply on any contracting information such as Incoterms etc, always include the e-mail address: [ILHQcontract-ILHQcontrat@forces.gc.ca](mailto:ILHQcontract-ILHQcontrat@forces.gc.ca) in carbon copy (cc).  
OR
- d. Insert the following for U.S. Foreign Military Sales (FMS):  
Inbound Logistics Coordination Center (ILCC):  
Telephone: 1-877-447-7701 (toll free)  
Facsimile: 1-877-877-7409 (toll free)  
Email: [ILHQOttawa@forces.gc.ca](mailto:ILHQOttawa@forces.gc.ca)  
Canada is responsible for the carrier selection for shipments of the goods supplied under this FMS contract. Instructions on how to obtain carrier selection from Canada are contained in U.S. Department of Defense 4000.25-8-M, Military Assistance Program Address Directory, and Canadian Special Instructions Indicator (SII). The Contractor must not ship the goods until the SII has been complied with.

3. The Contractor must provide the following information to the DND Inbound Logistics contact when arranging for shipment:
  - a. the Contract number;
  - b. consignee address (if multiple addresses, items must be packaged and labeled separately with each consignee address);
  - c. description of each item;
  - d. the number of pieces and type of packaging (e.g. carton, crate, drum, skid);
  - e. actual weight and dimensions of each piece type, including gross weight;
  - f. copy of the commercial invoice (in accordance with clause [C2608C](#), section 4, of the [Standard Acquisition Clauses and Conditions Manual](#)) or a copy of the Canada Border Services Agency form CI1 [Canada Customs Invoice](#) (PDF 429KB) - ([Help on File Formats](#));
  - g. [Schedule B](#) codes (for exports) and the Harmonized Tariff Schedule codes (for imports);
  - h. Canada-United States-Mexico Agreement Certification of Origin (in accordance with clause [C2608C](#), section 2) for the U.S. and Mexico only;
  - i. full details of dangerous material, as required for the applicable mode of transportation, signed certificates for dangerous material as required for shipment by the International Maritime Dangerous Goods Code, or International Air Transport Association regulations or the applicable Canadian [Dangerous Goods Shipping Regulations](#) and a copy of the safety data sheet.
4. Following receipt of this information by Canada, Canada will provide the appropriate shipping instructions, which may include the requirement for specific consignee address labelling, the marking of each piece with a Transportation Control Number and customs documentation.
5. The Contractor must not ship goods before receiving shipping instructions from the DND Inbound Logistics contact.
6. If the Contractor delivers the goods at a place and time that are not in accordance with the given delivery instructions or fail to fulfill reasonable delivery instructions given by Canada, the Contractor must reimburse Canada any additional expenses and costs incurred.
7. If Canada is responsible for delays in delivering the goods, ownership and risk will be transferred to Canada upon expiry of either 30 days following the date on which a duly completed shipping application is received by Canada or by its appointed forwarding agent, or 30 days following the delivery date specified in the Contract, whichever is later.

#### 6.18 Dispute Resolution

- (a) The parties agree to maintain open and honest communication about the Work throughout and after the performance of the contract.

- 
- (b) The parties agree to consult and co-operate with each other in the furtherance of the contract and promptly notify the other party or parties and attempt to resolve problems or differences that may arise.
- (c) If the parties cannot resolve a dispute through consultation and cooperation, the parties agree to consult a neutral third party offering alternative dispute resolution services to attempt to address the dispute.
- (d) Options of alternative dispute resolution services can be found on Canada's Buy and Sell website under the heading "[Dispute Resolution](#)".

## 6.19 Equivalency of Equipment

### 6.19.1 Equivalent Products – Contract

- a) The Contractor guarantees that the equipment to be delivered under the Contract is:
- i. equivalent in form, fit, function and quality to the equipment requested by Canada that was described in the bid solicitation that resulted in the Contract
  - ii. fully compatible, interchangeable and interoperable with the existing equipment owned by Canada.
- b) The Contractor also guarantees that any warranties with third parties concerning the existing equipment owned by Canada will not be adversely affected by Canada's use of the equipment delivered under the Contract (for example, by interconnecting the equipment) or by any other services provided by the Contractor under the Contract. If Canada determines in its sole discretion that any such warranty has been adversely affected, at Canada's sole option, the Contractor must:
- i. pay to Canada the amount that Canada must pay to the original supplier (or an authorized reseller of that supplier) to re-certify Canada's existing equipment for warranty purposes and any other amounts paid by Canada to a third party in order to restore the equipment to full warranty status;
  - ii. perform all warranty work on Canada's existing equipment in place of the original supplier; or
  - iii. pay to Canada the amount that Canada must pay to the original supplier (or an authorized reseller of that supplier) to perform maintenance work on the equipment that otherwise would have been covered by the warranty.
- c) The Contractor agrees that, during the Contract Period, if Canada determines that any of the equipment is not equivalent in form, fit, function and quality to the existing equipment owned by Canada or is not fully compatible, interchangeable and interoperable with the existing equipment owned by Canada, the Contractor must immediately and entirely at its own expense take all steps necessary to ensure that the equipment satisfies these requirements (for example, by implementing any additional software or firmware), failing which Canada will have the immediate right to terminate the Contract for default. The Contractor agrees that, if Canada terminates the Contract for this reason, the Contractor must pay to Canada the costs of reprocurring the equipment from a third party and the difference, if any, in price paid by Canada to the third party. The Contractor acknowledges that its failure to deliver equivalent equipment that satisfies the above requirements may result in the Contractor (as well as its affiliates and any other entities with whom the Contractor or its principals do not deal at arm's length) being unable to propose

Solicitation No. - N° de l'invitation

W8482-218501/A

Client Ref. No. - N° de réf. du client

XXXXX-XXXXXX

Amd. No. - N° de la modif.

File No. - N° du dossier

xxxxx.XXXXX-XXXXXX

Buyer ID - Id de l'acheteur

25H

CCC No./N° CCC - FMS No./N° VME

---

equivalent substitutes in response to future DND bid solicitations.

Note to Bidders: This article will only be included in a resulting contract if equivalent products have been proposed.

**ANNEX A - LINE ITEM DETAILS**

Item	Description <i>Further detail provided at Annex C - Long Text Description</i>	Unit of Issue	Quantity	Delivery and Invoice Codes <i>Definition can be found at Appendix 1 to Annex A</i>	Security Requirement	Quality Assurance Code (QAC)	Controlled Goods (CTAT or ITAR)	Trade Agreement
001	NSN: 4030-21-890-0167 Name: HOOK ASSEMBLY, PELICAN PN Requested: 8265108 NCAGE: 28208 Manufacturer: HEPBURN ENGINEERING INC  OR EQUIVALENT Equivalent offers must comply with RFP Equivalent Products clauses and specify: PN offered: _____ NCAGE: _____ Manufacturer: _____	EA	6	CFB Halifax Delivery Code  007X Invoice Code  W010B	No	Q	No	Yes
002	NSN: 4030-21-890-0167 Name: HOOK ASSEMBLY, PELICAN PN Requested: 8265108 NCAGE: 28208 Manufacturer: HEPBURN ENGINEERING INC  OR EQUIVALENT Equivalent offers must comply with RFP Equivalent Products clauses and specify: PN offered: _____ NCAGE: _____ Manufacturer: _____	EA	4	CFB Esquimalt Delivery Code  002E Invoice Code  W0103	No	Q	No	Yes

Solicitation No. - N° de l'invitation  
W8482-218501/A  
Client Ref. No. - N° de réf. du client  
XXXXX-XXXXXX

Amd. No. - N° de la modif.  
File No. - N° du dossier  
xxxxx.XXXXX-XXXXXX

Buyer ID - Id de l'acheteur  
25H  
CCC No./N° CCC - FMS No./N° VME

**APPENDIX 1 TO ANNEX A - DELIVERY AND INVOICE CODES**

<b>Supply Depot</b>	<b>Delivery Code</b>	<b>Delivery Address</b>	<b>Invoice Code</b>	<b>Invoice Address</b>
CFB HALIFAX	007X	Department of National Defence CFB Halifax Main Warehouse Bldg D206 Door 1 thru 13 HMC Dockyard Halifax, NS B3K 5X5 Canada	W010B	Department of National Defence Maritime Forces Atlantic Accts Payable Bldg. S90, Room 334 2686 Sextant Lane, Stadacona P.O. Box 99000, Stn Forces Halifax NS B3K 5X5 Canada hfxaccountspayable@forces.gc.ca
CFB ESQUIMALT	002E	Department. of National Defence CFB Esquimalt Attn: Receiving Bldg 66 Colwood Victoria, BC V9C 1B0 Canada	W0103	Department. of National Defence Base Logistics Officer CFB Esquimalt Stn Forces P.O. Box 17000 Victoria, BC V9A 7N2 Canada ESQBLOGAcctsPayable@forces.gc.ca

**ANNEX B - BASIS OF PAYMENT**

Item	Description	Unit of Issue	Quantity	Delivery and Invoice Codes <i>Definition can be found at Appendix 1 to Annex A</i>	FIRM UNIT PRICE: Customs and duties excluded, applicable taxes extra	EXTENDED PRICE: Applicable taxes extra	Applicable taxes (%)
001	NSN: 4030-21-890-0167 Name: HOOK ASSEMBLY, PELICAN	EA	6	CFB Halifax Delivery Code 007X Invoice Code W010B			
002	NSN: 4030-21-890-0167 Name: HOOK ASSEMBLY, PELICAN	EA	4	CFB Esquimalt Delivery Code 002E Invoice Code W0103			

**ANNEX B - BASIS OF PAYMENT**

	<b>Extended Price</b>	<b>Applicable Taxes (%)</b>	<b>Taxes</b>	<b>Price with Taxes</b>
<b>CFB Halifax</b>				
<b>CFB Esquimalt</b>				
			<b>Subtotal</b>	
			<b>Total Taxes</b>	
			<b>Total (CAD)</b>	



Solicitation No. - N° de l'invitation

W8482-218501/A

Client Ref. No. - N° de réf. du client

XXXXX-XXXXXX

Amd. No. - N° de la modif.

File No. - N° du dossier

xxxxx.XXXXX-XXXXXX

Buyer ID - Id de l'acheteur

25H

CCC No./N° CCC - FMS No./N° VME

---

## ANNEX "C" - LONG TEXT DESCRIPTION

### Item Identification

**NSN:** 4030-21-890-0167

**ITEM NAME:** HOOK ASSEMBLY, PELICAN

### Narrative Description

1 IN. NOM DIA MATL;C/O 1 EACH LONG LINK,RELEASING LINK,PELICAN  
HOOK,CONNECTING LINK AND BRASS COTTER PIN 0.250 IN. BY 2.500 IN. ;FOR  
REPLENISHMENT AT SEA

Eighths Huitièmes 0 1 2 3 4 5 6 7 8 9 10 Tenths Dixièmes

-NO	ITEM NO. DE L'ART	IDENTIFYING NO. D'IDENTIFICATION	NOMENCLATURE	DESCRIPTION	SPECIFICATION	NSCM CAOF
1	1	8265109-1	LINK, LONG			
1	2	8265110-1	HOOK, PELICAN			
1	3	8265111-1	LINK, RELEASING			
1	4	RR-C 271A	LINK, CONNECTING GR-C-STL			
1	5		PIN, COTTER, BRASS 1/4 DIA x 2 1/2 LG			

Millimetres  
Millimètres  
0 20 40 60 80 100 120 140 160 180 200

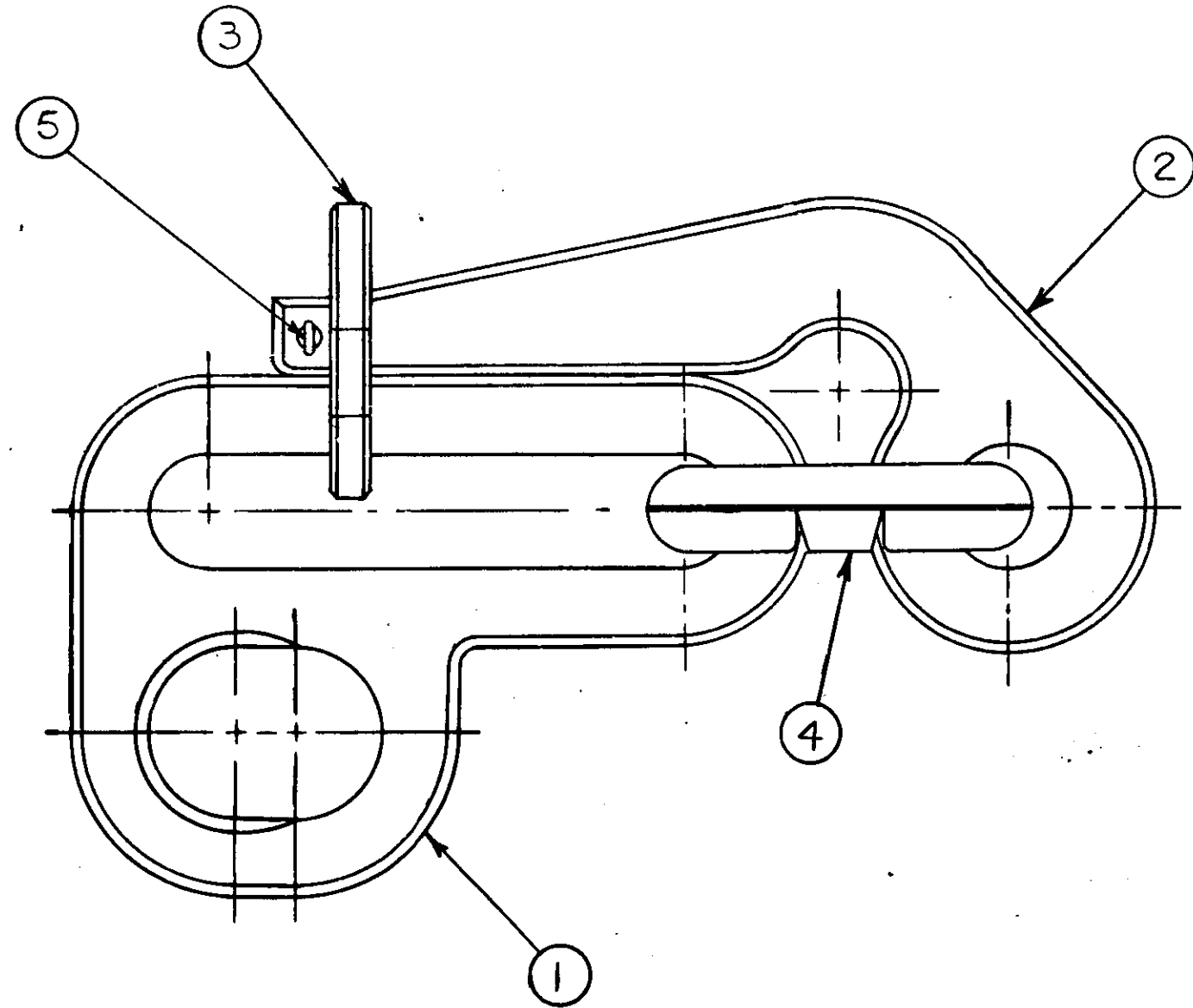

NOTES:

1. THIS DRAWING DEVELOPED TO PROVIDE A LIGHT WEIGHT PELICAN HOOK OF SUFFICIENT STRENGTH AND SIZE TO ATTACHMENT POINTS IN "UNREP" RIGS TESTED TO 50,000 LBS.
2. THE RECESS IN THE PELICAN HOOKS CAN ACCOMODATE ATTACHMENT POINTS LONG LINKS UP TO AND INCLUDING 1 1/2" DIA. STOCK ROUND BARS.
3. PELICAN HOOKS HAS BEEN DESIGNED TO WITHSTAND A 50,000 LBS STATIC TEST WITHOUT ANY PERMANENT DEFORMATION OF ANY OF IT'S PARTS.
4. GALVANIZE ALL PARTS AFTER ASSEMBLY
5. DEVIATIONS ARE PERMITTED IN MANUFACTURING PROCESS IF APPEARANCE, FUNCTION AND STRENGTH ARE NOT IMPAIRED NOR WEIGHT INCREASED. MAX. WEIGHT 20 LBS.
6. ALL WELDING SHALL BE IN ACCORDANCE WITH CR 70 C49-003-003/SG-001/CSA W-47-1

SEE DATA LIST 8265108

NSN 4030-21-890-0167

UNLESS OTHERWISE SPECIFIED: SAUF INDICATION CONTRAIRE		APPLICATION/USAGE		ZONE	LTR LET	REVISION	DATE	DWN DES	CKD VER	APPVL APP
1. DIMENSIONS ARE IN INCHES DIMENSIONS SONT EN	2. TOLERANCES FRACTIONS ± — DECIMALS ± — DECIMALES			DND - CANADIAN FORCES CANADIENNES - MDN			CF APPVY APP FC			
3. SURFACE FINISH FINIS DE SURFACES	✓			DWN/DESS A. TROTTIER	CKD/VER C. GENDRON	QA/AQ D.P.	DRAWING DATE DU DESSIN 82-07-16	A2		
4. ORIGINAL SCALE ÉCHELLE ORIGINALE	1/2			DESIGN AGENT/CONCEPTION DGMEM/DMEE5	NSCM/CAOF 36219	DRAWING NO. DU DESSIN 8265108		SHEET OF FEUILLE DE 1		
DRAWING INTERPRETATION INTERPRETER LE DESSIN PAR		CF D-01-400-001/SG-000 LEVEL/NIVEAU — 3		TITLE/TITRE HOOKS, 1", PELICAN ASSY						

Solicitation No. - N° de l'invitation

W8482-218501/A

Client Ref. No. - N° de réf. du client

XXXXX-XXXXXX

Amd. No. - N° de la modif.

File No. - N° du dossier

xxxxx.XXXXX-XXXXXX

Buyer ID - Id de l'acheteur

25H

CCC No./N° CCC - FMS No./N° VME

---

## **ANNEX "D" to PART 3 OF THE BID SOLICITATION - ELECTRONIC PAYMENT INSTRUMENTS**

The Bidder accepts any of the following Electronic Payment Instrument(s):

- Direct Deposit (Domestic and International);
- Electronic Data Interchange (EDI);
- Wire Transfer (International Only).