



Fisheries and
Oceans Canada

Real Property

Pêches
et Océans

Garde cotiere

P.O. BOX 5667
ST. JOHN'S, NEWFOUNDLAND AND LABRADOR
A1C 5X1

VHF GENERATOR BUILDING — ST. LAWRENCE

DRAWING LIST:

A1	ELEVATIONS
A2	FLOOR, ROOF AND ICE-SHIELD PLANS
A3	SECTIONS AND DETAILS
A4	TYPICAL DETAILS
A5	DOOR SCHEDULE AND DETAILS
S1	FRAMING PLAN, SECTIONS AND DETAILS
S2	FOUNDATION SECTIONS AND DETAILS
M1	VENTILATION SYSTEM PLANS AND DETAILS
M2	MECHANICAL PENETRATIONS
E1	ELECTRICAL LAYOUT AND LEGEND
E2	ELECTRICAL DETAILS
E3	ELECTRICAL DETAILS AND PANEL SCHEDULES
E4	GROUNDING PLAN
N1	ARCHITECTURAL AND STRUCTURAL NOTES
N2	MECHANICAL NOTES
N3	ELECTRICAL NOTES

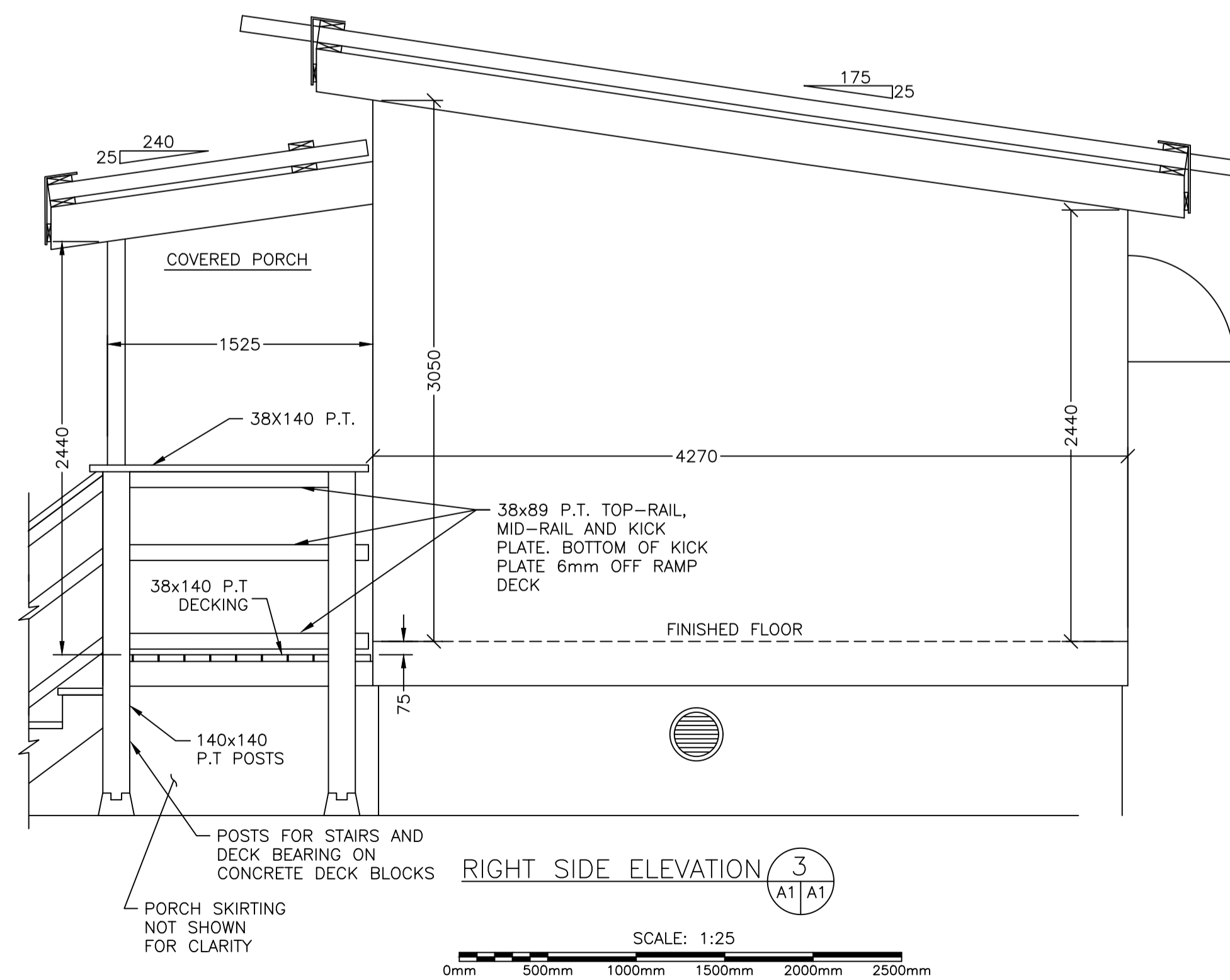
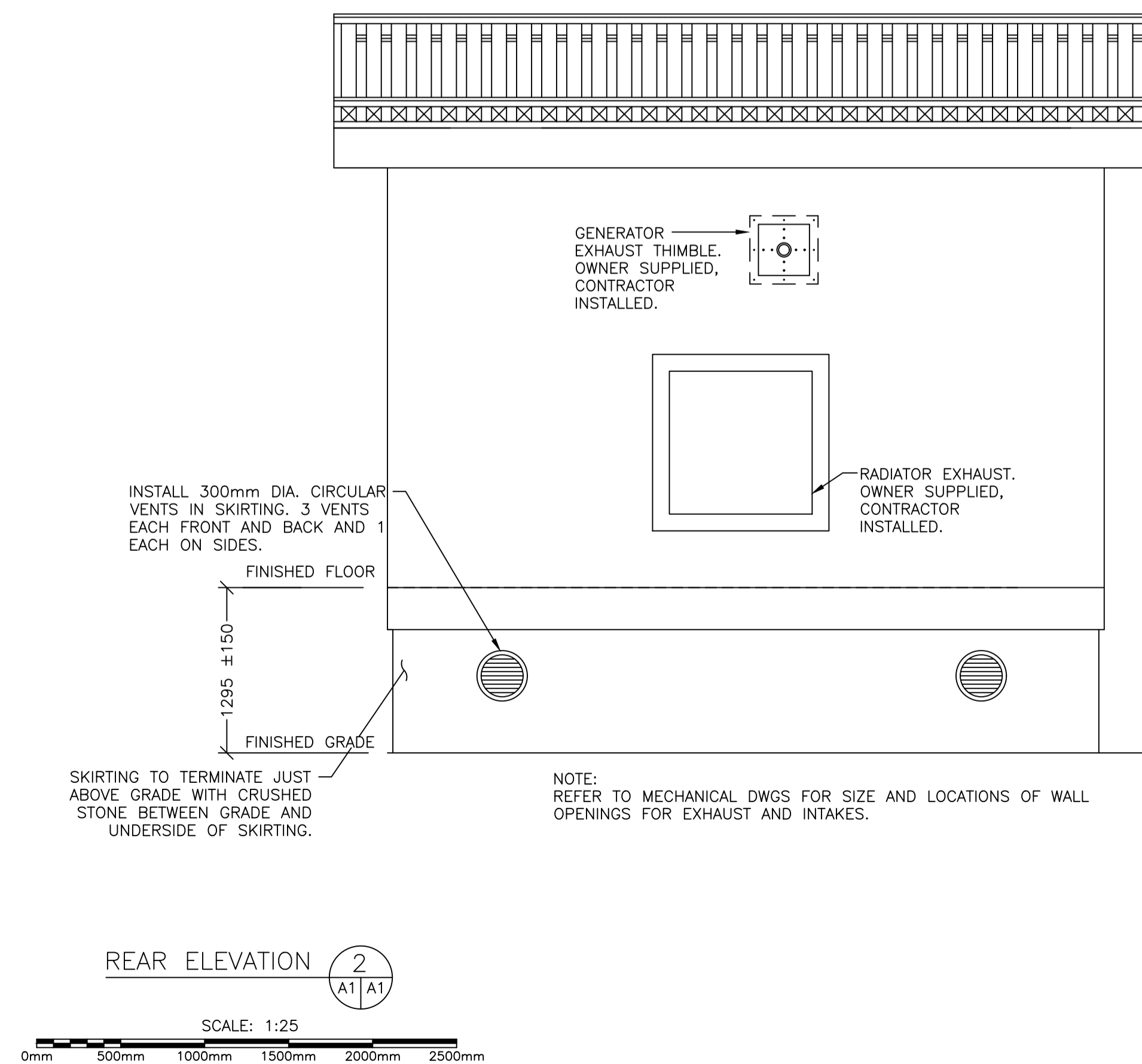
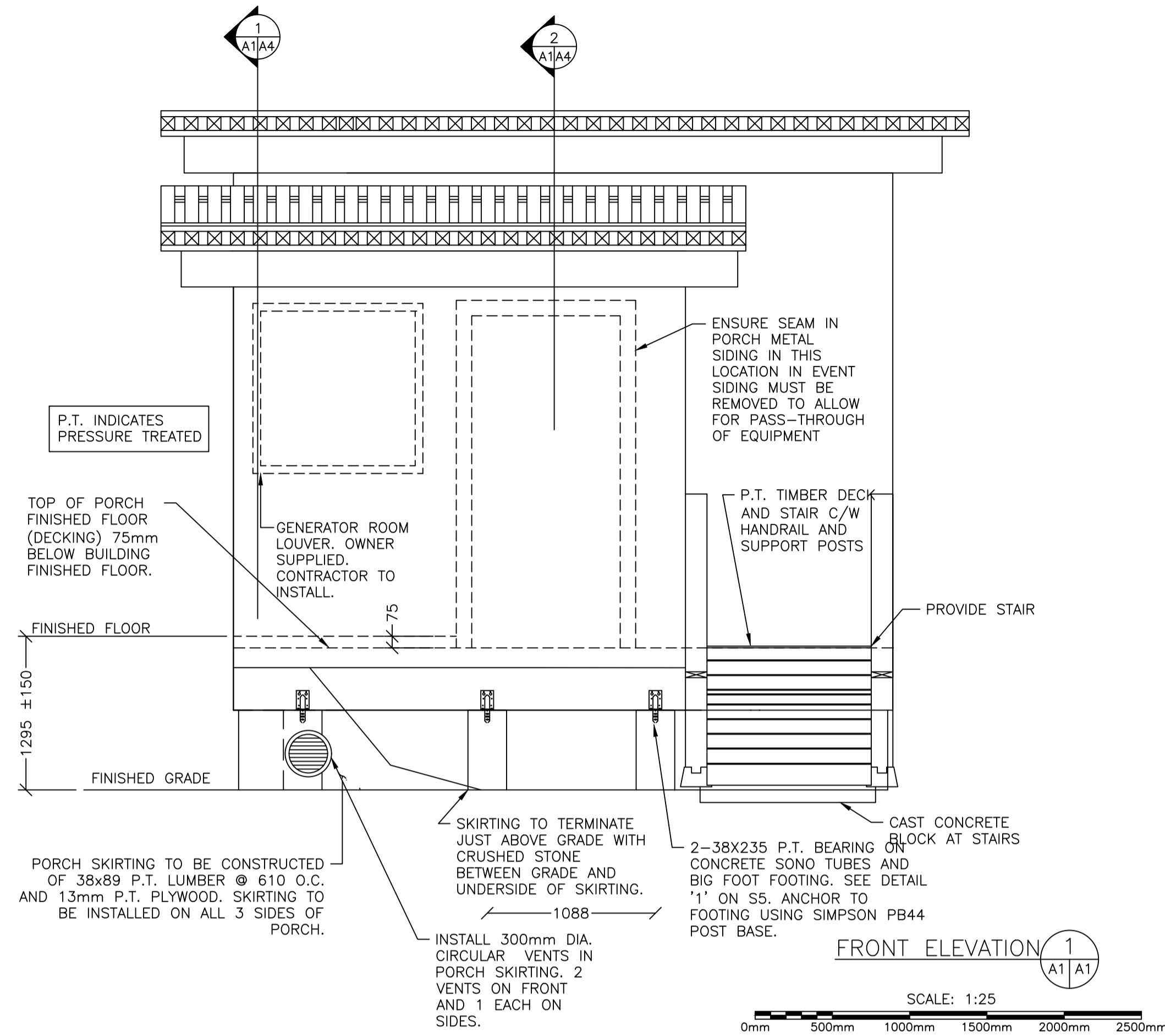

A - INDICATES DETAIL NO.
 B - INDICATED SHEET DETAIL IS REQUIRED
 C - INDICATES SHEET DETAIL IS DRAWN

no.	revision	date	by	approved
2	REVISED	28/10/2020	MH	RB
1	ISSUED FOR CONSTRUCTION	16/11/2018	JS	RN
0	ISSUED FOR TENDER	18/06/20	JS	RN

Project - projet
MCTS GENERATOR BLDG
ST. LAWRENCE

Drawing - dessin
ELEVATIONS

drawn - dessine	M.G.G.	designed - dessine par	D.N.
date - date	AUGUST 2020	checked - verifie	R.N.
scale - echelle	AS SHOWN	approved for tender - approuve pour l'offre	R.N.
project no. - projet no.	drawing no. - no du dessin	sheet - feuille	
	01L1402B02901-A01	1 OF 16	

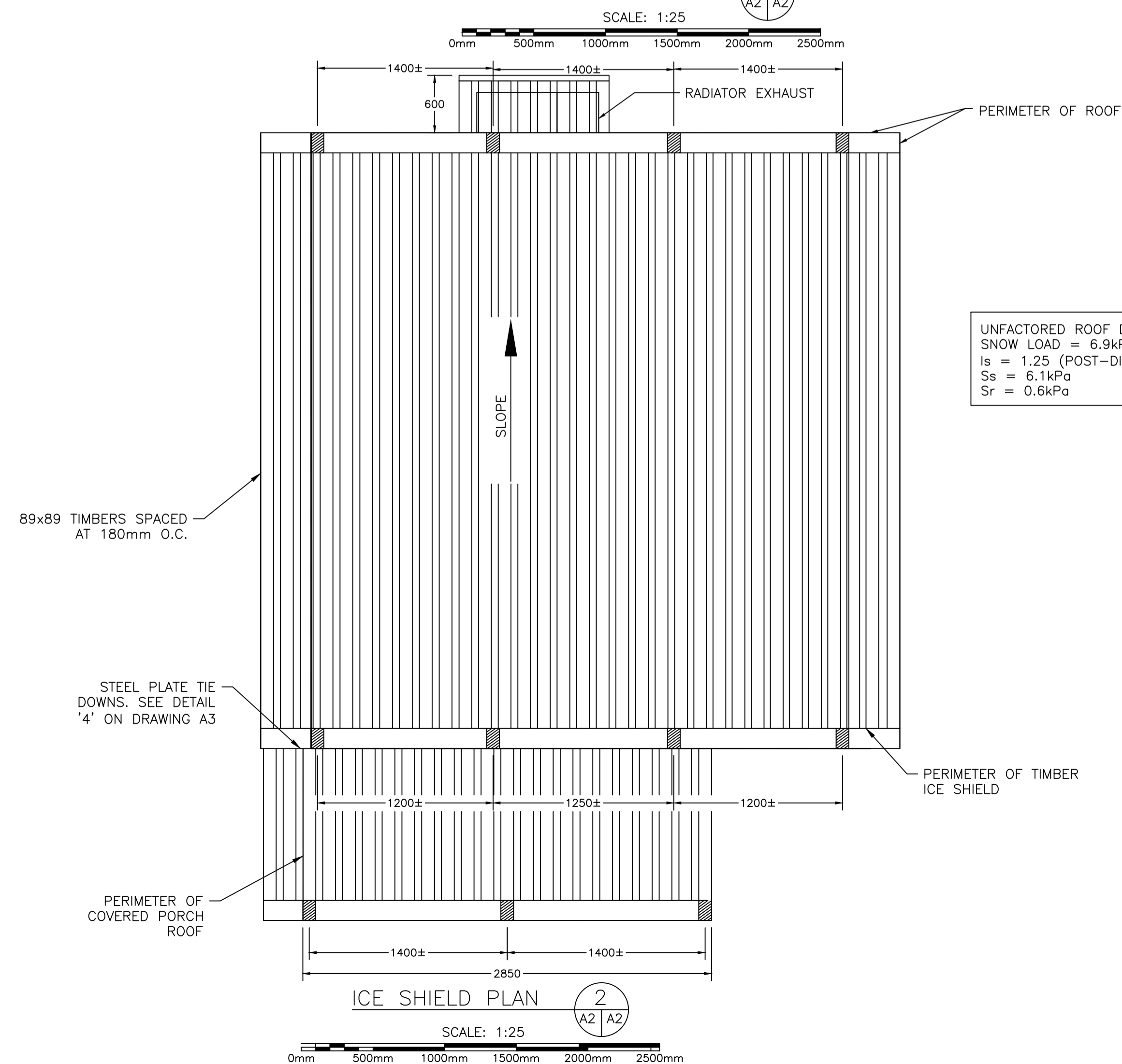
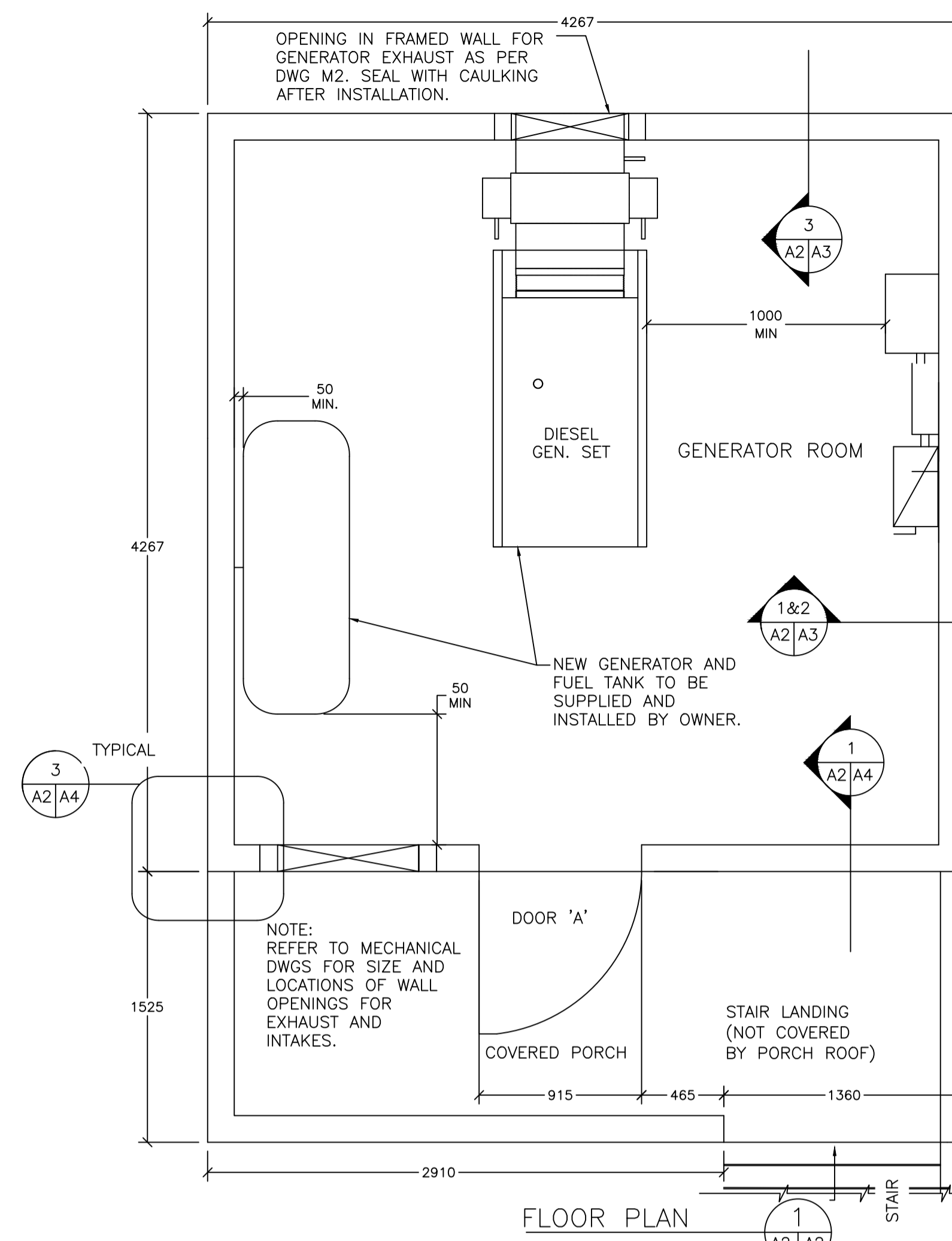

A - INDICATES DETAIL NO.
 B - INDICATED SHEET DETAIL IS REQUIRED
 C - INDICATES SHEET DETAIL IS DRAWN

2	REVISED	28/10/2020	MH	RB
1	ISSUED FOR CONSTRUCTION	16/11/2018	JS	RN
0	ISSUED FOR TENDER	18/06/20	JS	RN
no. no	revision	date	by	approved
	revision	date	par	approuvé

Project - projet
MCTS GENERATOR BLDG
ST. LAWRENCE

Drawing - dessin
FLOOR, ROOF AND
ICE-SHIELD PLANS

drawn - dessiné	M.G.G.	designed - dessiné par	D.N.
date - date	AUGUST 2020	checked - vérifié	R.N.
scale - échelle	AS SHOWN	approved for tender - approuvé pour l'offre	R.N.
project no. - projet no.	drawing no. - no du dessin	sheet - feuille	
	01L1402B02902-A02	2 OF 16	

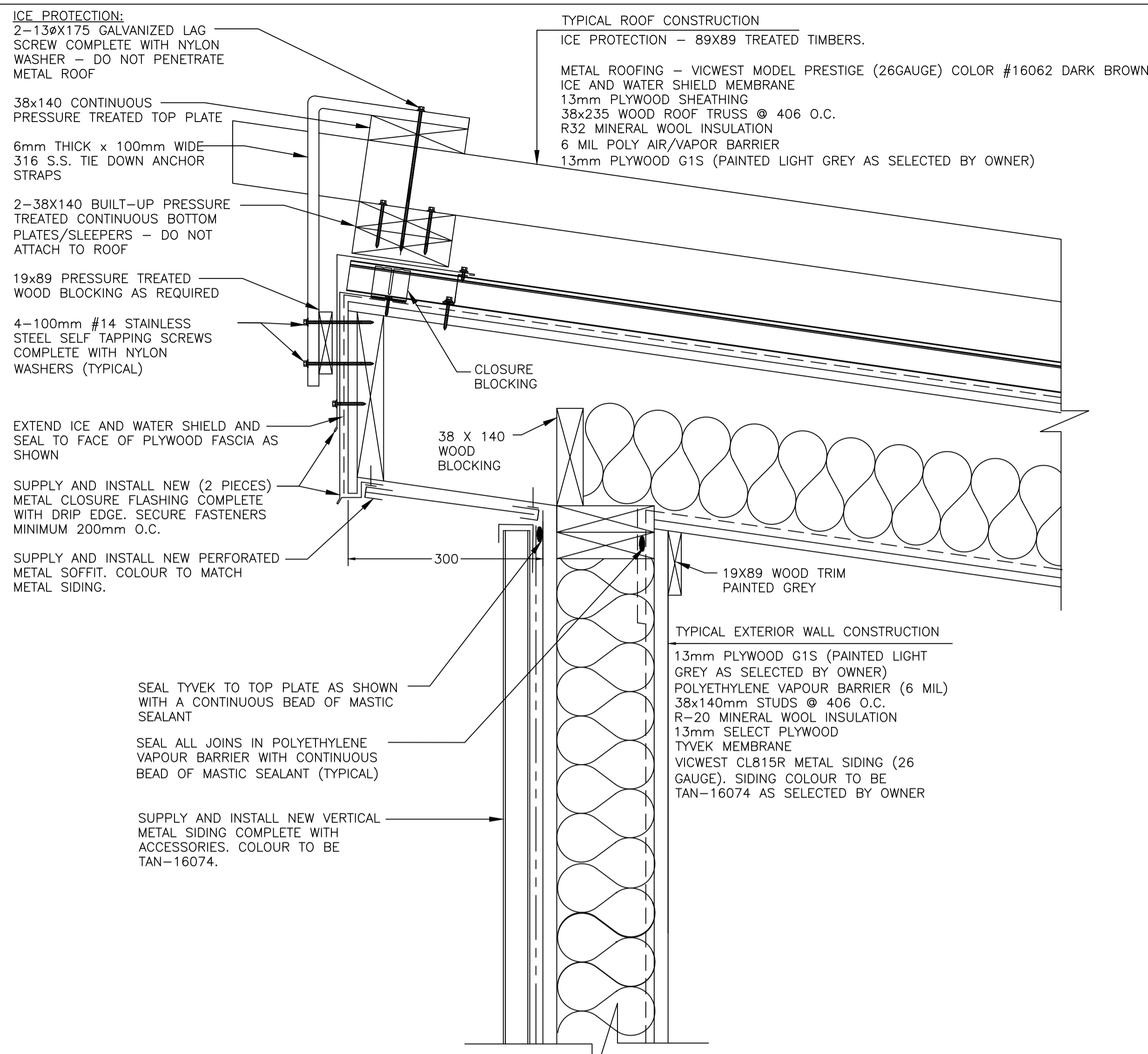

TYPICAL ROOF DETAIL WITH ICE PROTECTION 1
 SCALE: 1:5
 0mm 100mm 200mm 300mm 400mm 500mm

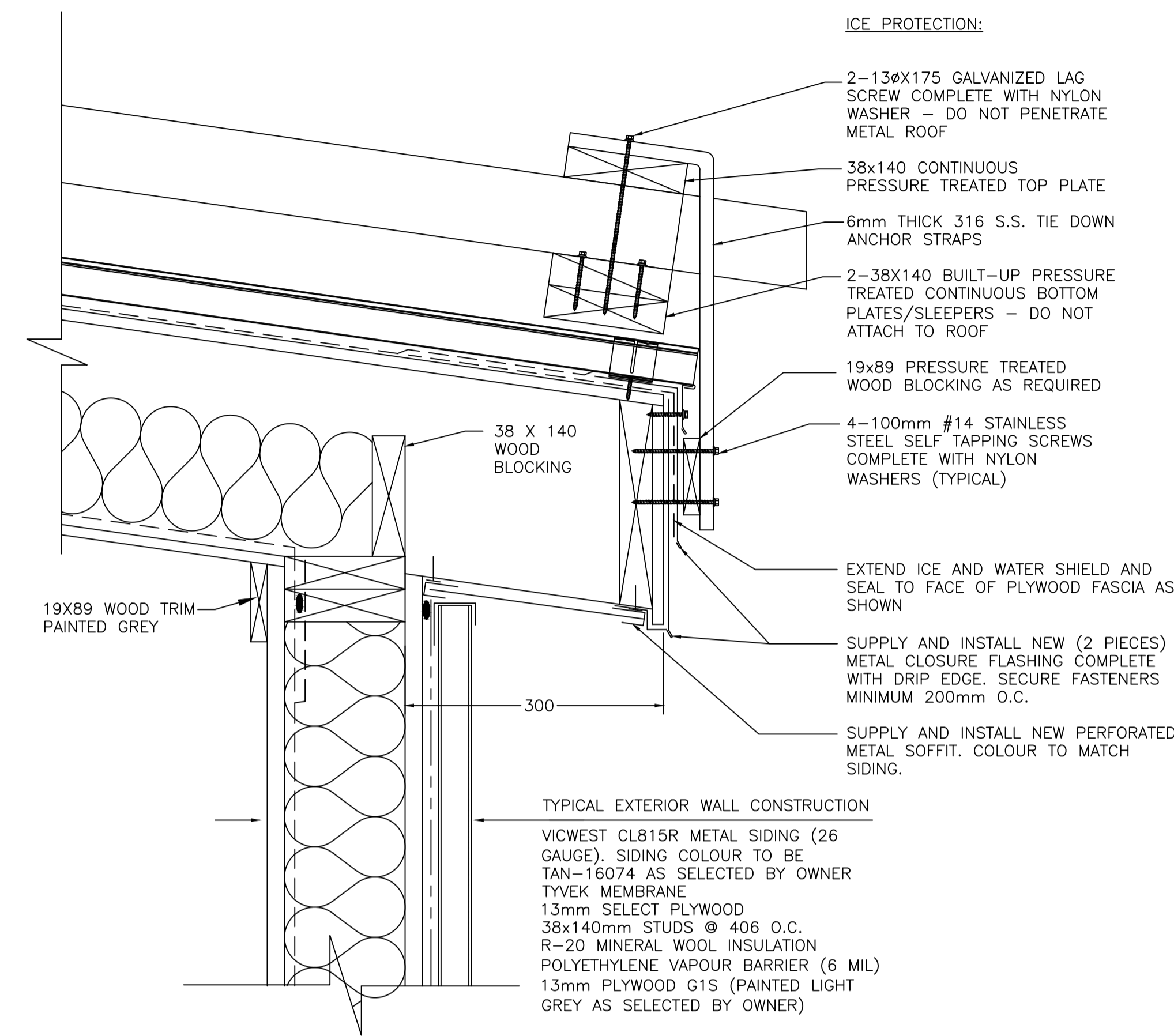

3 TYPICAL ROOF DETAIL WITH ICE PROTECTION
 SCALE: 1:5
 500mm 400mm 300mm 200mm 100mm 0mm

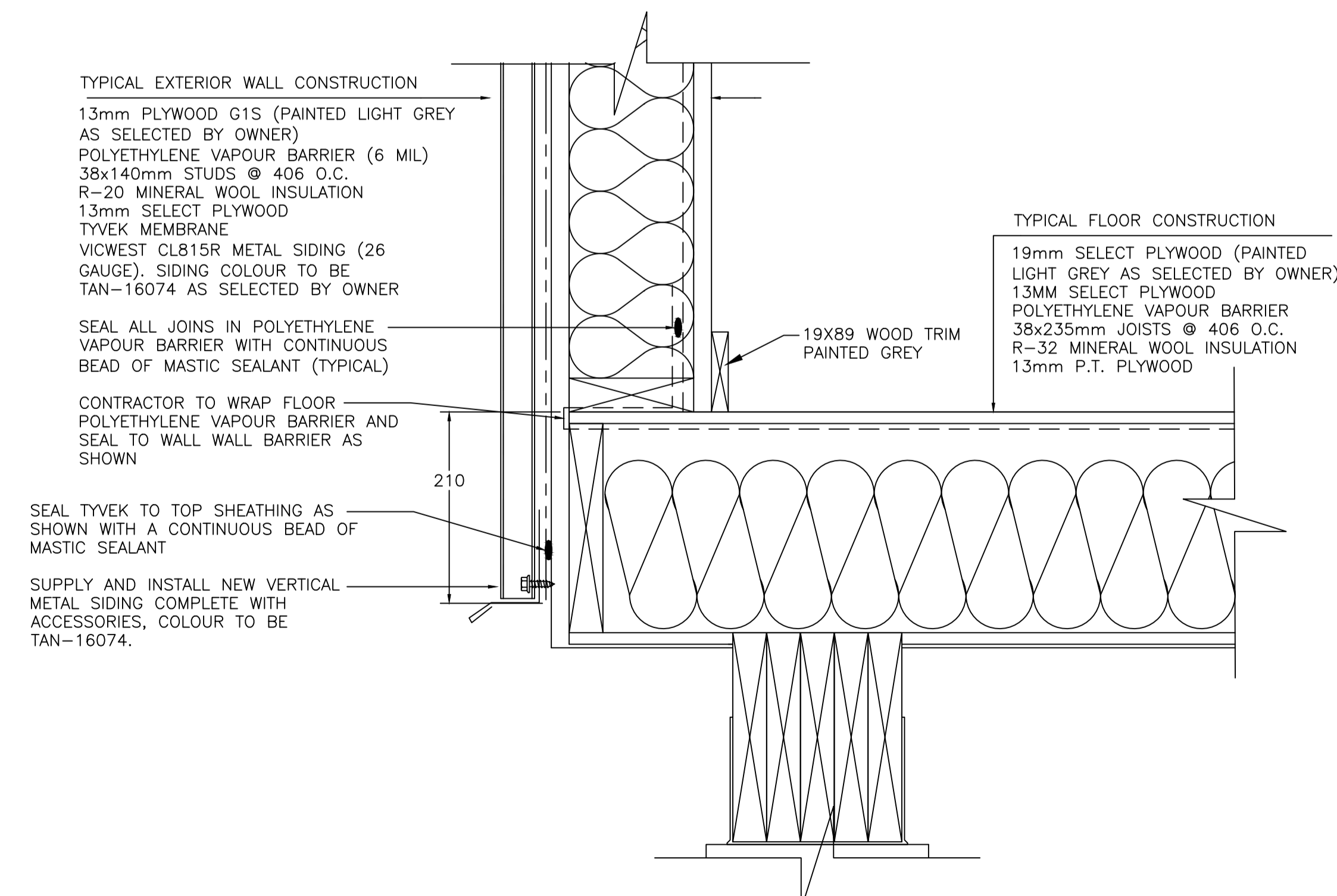

TYPICAL EXTERIOR WALL/FLOOR DETAIL 2
 SCALE: 1:5
 0mm 100mm 200mm 300mm 400mm 500mm

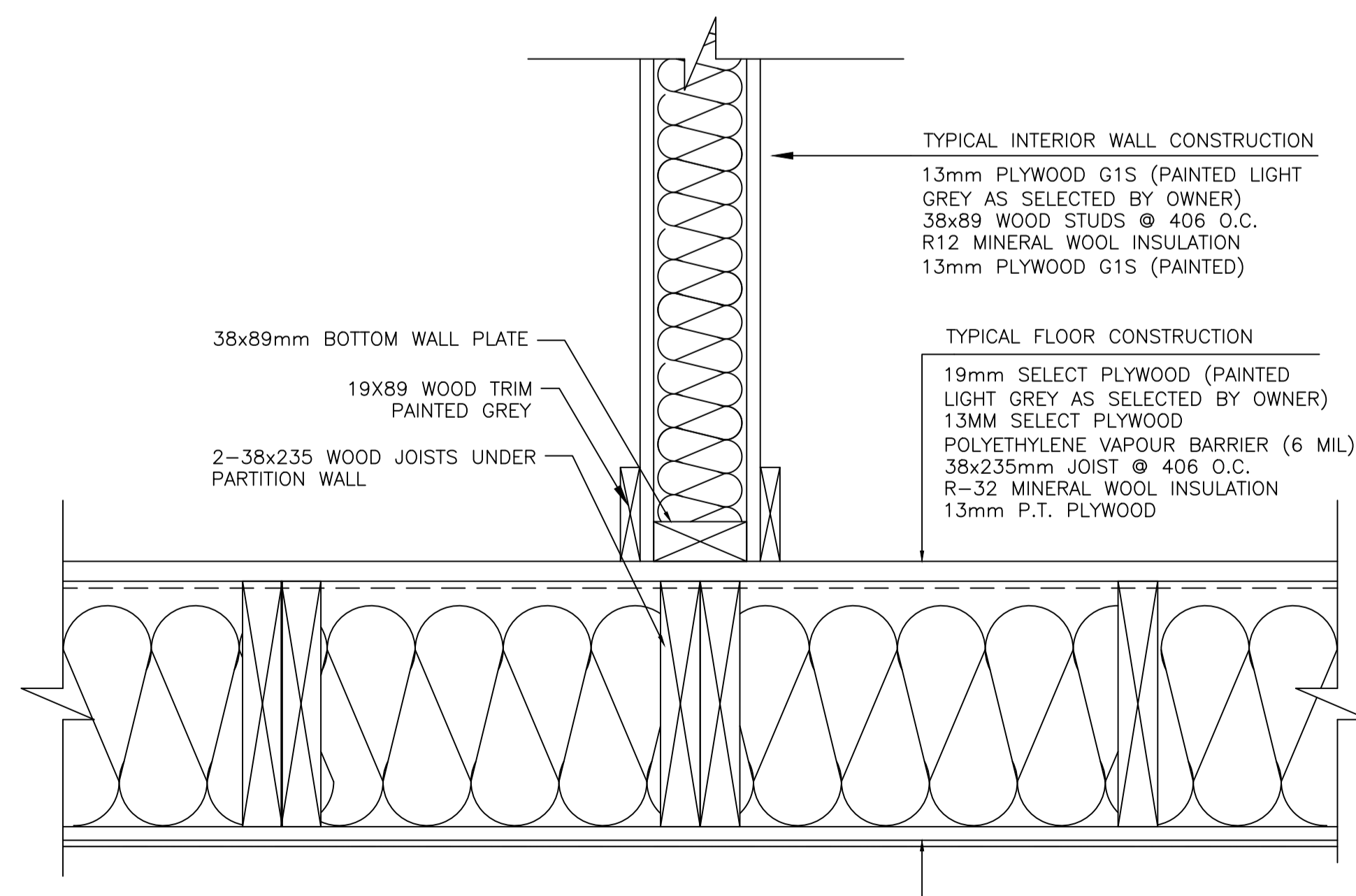

FLOOR/INTERIOR PARTITION WALL DETAIL 4
 SCALE: 1:5
 0mm 100mm 200mm 300mm 400mm 500mm

A - INDICATES DETAIL NO.
 B - INDICATED SHEET DETAIL IS REQUIRED
 C - INDICATES SHEET DETAIL IS DRAWN

no	revision	date	par	approve
2	REVISED	28/10/2020	MH	RB
1	ISSUED FOR CONSTRUCTION	16/11/2018	JS	RN
0	ISSUED FOR TENDER	18/06/20	JS	RN

Project - projet
**MCTS GENERATOR BLDG
 ST. LAWRENCE**

Drawing - dessin
SECTIONS AND DETAILS

drawn - dessine	M.G.G.	designed - dessine par	D.N.
date - date	AUGUST 2020	checked - verifie	R.N.
scale - echelle	AS SHOWN	approved for tender - approuve pour l'offre	R.N.
project no. - projet no.	drawing no. - no du dessin	sheet - feuille	
	01L1402B02903-A03	3 OF 16	

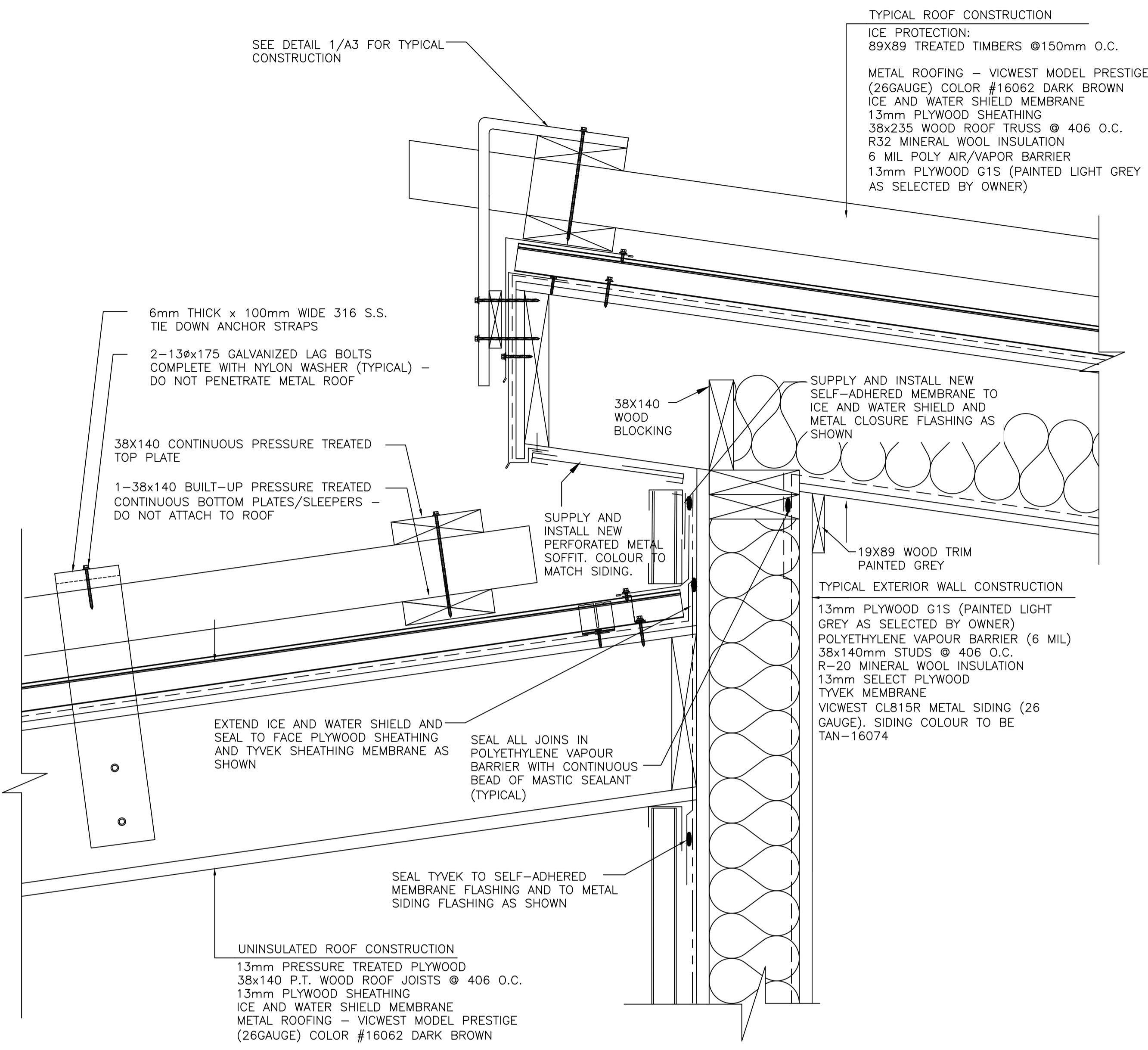

TYPICAL PORCH/TRAILER INTERFACE WITH ICE PROTECTION

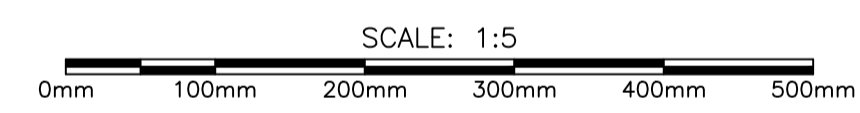

1
A2/A4

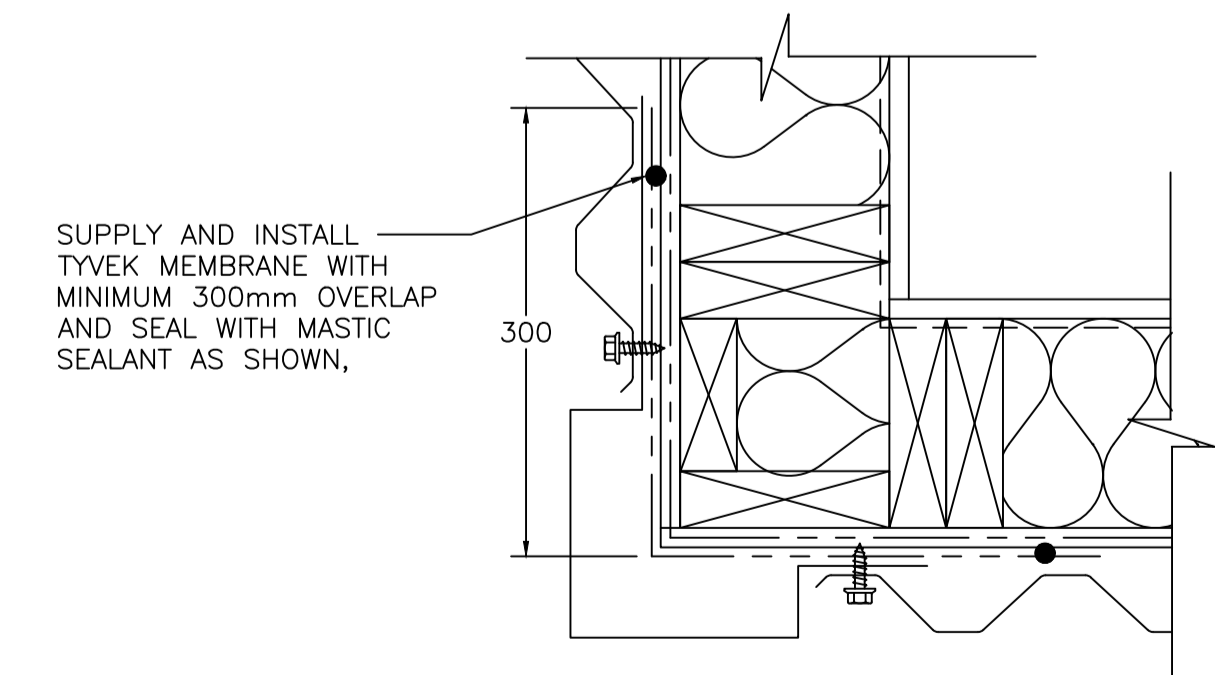

TYPICAL OUTSIDE CORNER DETAIL

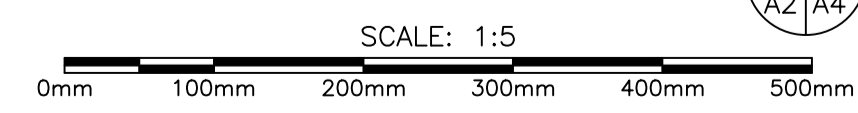

3
A2/A4

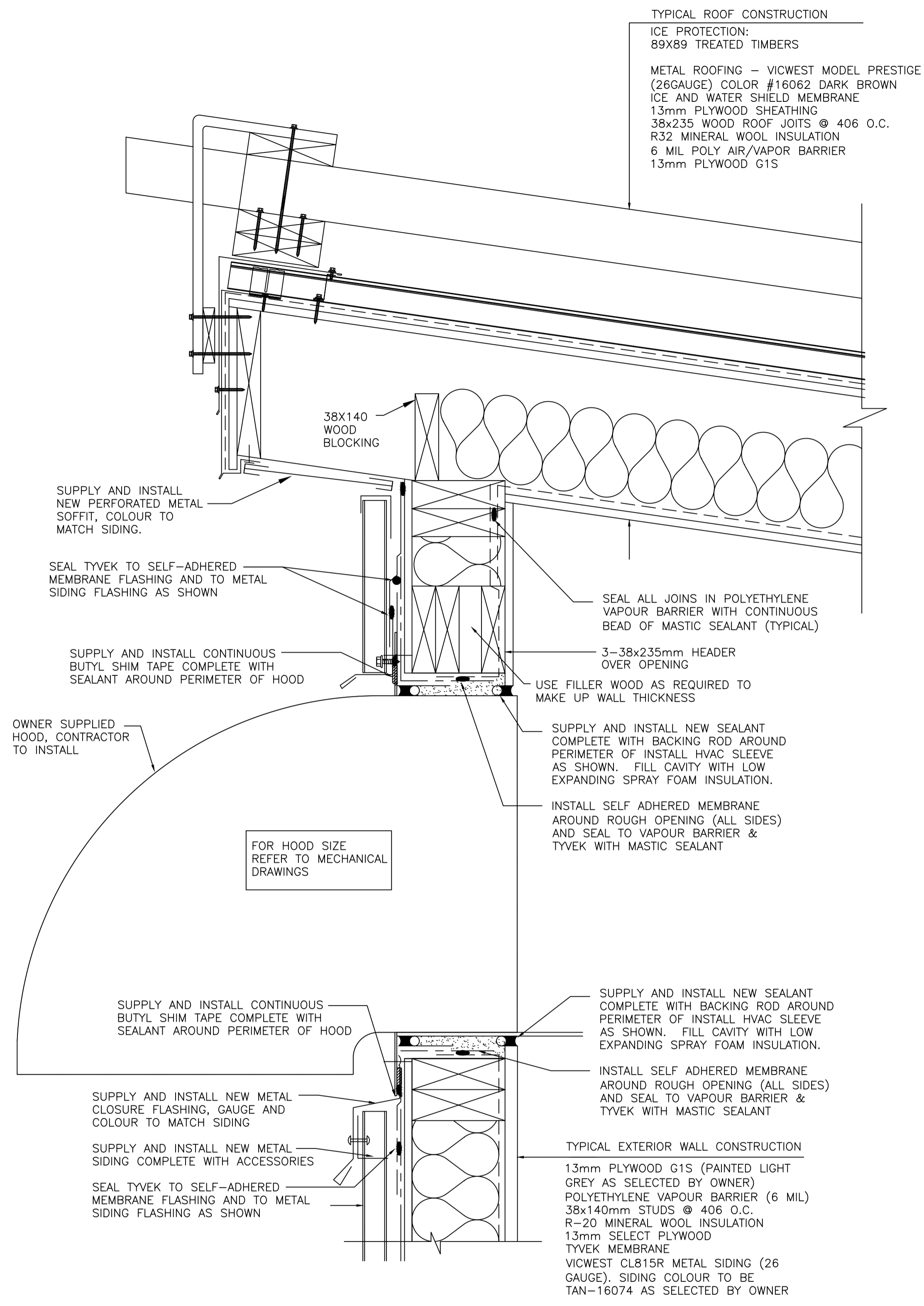

TYPICAL MECHANICAL OPENING DETAIL

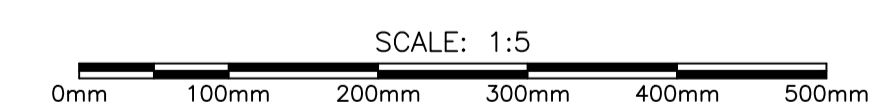

2
A2/A4

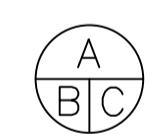
 A – INDICATES DETAIL NO.
 B – INDICATED SHEET DETAIL IS REQUIRED
 C – INDICATES SHEET DETAIL IS DRAWN

no.	revision	date	by	approved
2	REVISED	28/10/2020	MH	RB
1	ISSUED FOR CONSTRUCTION	16/11/2018	JS	RN
0	ISSUED FOR TENDER	18/06/20	JS	RN

Project – projet

MCTS GENERATOR BLDG
ST. LAWRENCE

Drawing – dessin

TYPICAL DETAILS

drawn – dessiné M.G.G. designed – dessinée par D.N.

date – date AUGUST 2020 checked – vérifié R.N.

scale – échelle AS SHOWN approved for tender – approuvé pour l'offre R.N.

project no. – projet no. drawing no. – no du dessin 01L1402B02904-A04 sheet – feuille 4 OF 16

DOOR FINISH SCHEDULE

REF.	LOCATION AND DESCRIPTION						DOORS				FRAMES			GLAZING			NOTES	HARDWARE										
	DOOR NUMBER	TYPE	WIDTH	HEIGHT	THICKNESS	LABEL (HOURS)	FACE	CORE	FINISH	GRILLE	MATERIAL	PROFILE	ELEVATION	FINISH	DOOR	SIDELIGHT		TRANSOM	BUTTS	PASSAGE LATCH SET	LOCK SET	CLOSER	PUSH / PULL	KICK PLATES	HOLDER STOP	THRESHOLD	WEATHER STRIPPING	DOOR BOTTOM
	A	HM	915	2050	45	0.75	A	PC	PT1	-	PGS	A	A	PT1	-	-	-	•	-	•	•	-	-	-	•	•	•	CRASH STOP, PANIC HARDWARE

LEGEND

- HC - HONEYCOMB CORE
- PC - POLYSTYRENE CORE
- PGS - PAINTABLE GALVANNEAL STEEL
- HM - HOLLOW METAL
- WD - WOOD
- PT1 - PRIME AND PAINT TWO (2) COATS WITH ALKYD BASED PAINT IN SEMI-GLOSS SHEEN
- PT2 - PRIME AND PAINT TWO (2) COATS LATEX SEMI-GLOSS SHEEN



TYPE 'A'

DOOR TYPE DETAIL
NTS

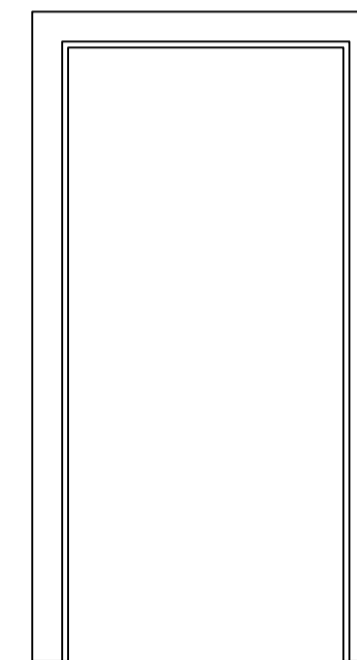

TYPE 'A'

FRAME TYPE DETAIL
NTS

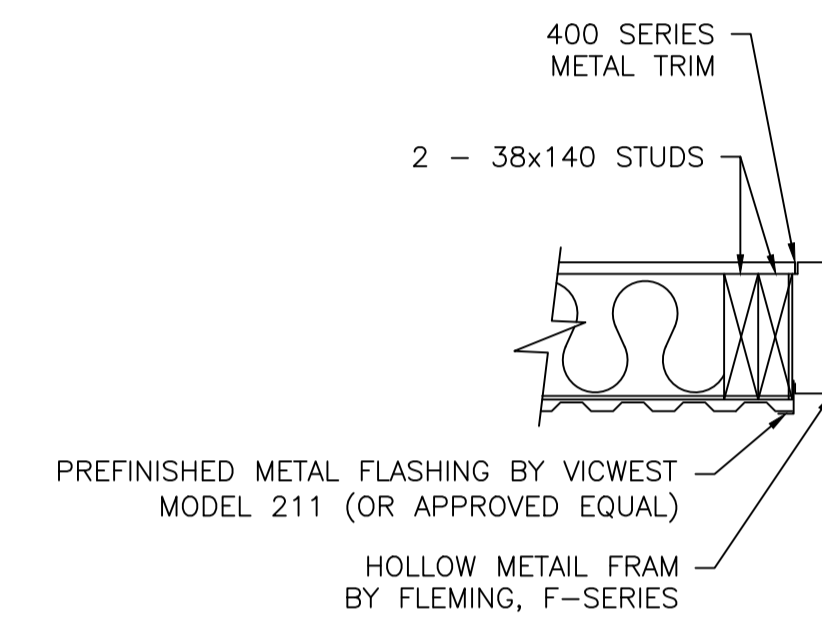

HOLLOW METAL FRAME
DOOR JAMB DETAIL TYPE 'A'
NTS

DOORS/FRAME/HARDWARE/NOTES:

1. ACCEPTABLE MATERIAL:
 - .1 DOOR FRAMES: FLEMING F16 SERIES WELDED FRAME.
 - .2 EXTERIOR DOORS: FLEMING D18 SERIES POLYSTYRENE CORE.
 - .3 HARDWARE (OR APPROVED EQUIVALENT):
LOCKSET: TO BE OWNER SUPPLIED FOLLOWING CONTRACT AWARD.
LATCH GUARD DR385A BY LOCKWOOD INDUSTRIES. LEVER HANDLE/DEADBOLT COMBO.

CLOSER: EN351-UO BY SARGENT
HINGES: MACPRO BY MCKINNEY - MPB91 NRP 114X101 (x6 PER LEAF)

WEATHER-STRIPPING: 303AV (2 X 2134) (1 X WIDTH) BY PEMKO
ADJUSTABLE WEATHER-STRIP ON THREE SIDES MITERED AT CORNERS.
EXTEND WEATHER-STRIPPING TO FLOOR. BUBBLE GASKET SEAL ON THREE SIDES.
DOOR BOTTOM: 345AV 914mm BY PEMKO
THRESHOLD: 185AT BY PEMKO
DOOR CHECK CHAINS: 3561 30-1/2" BY CANAROPA
2. INSTALL LABELED STEEL FIRE RATED DOORS AND FRAMES TO NFPA 80.
3. INSTALL DOORS AND FRAMES PER CDFMA INSTALLATION GUIDE.
4. SET FRAMES PLUMB, SQUARE, LEVEL AND CORRECT ELEVATION.
5. SECURE ANCHORAGES AND CONNECTIONS TO ADJACENT CONSTRUCTION.
6. BRACE FRAMES RIGIDLY IN POSITION WHILE BUILDING-IN. INSTALL TEMPORARY HORIZONTAL WOOD SPREADER AT THIRD POINTS OF DOOR OPENING TO MAINTAIN FRAME WIDTH. PROVIDE VERTICAL SUPPORT AT CENTRE OF HEAD FOR OPENINGS OVER 1200mm WIDE. REMOVE TEMPORARY SPREADERS AFTER FRAMES ARE BUILT-IN.
7. MAKE ALLOWANCES FOR DEFLECTION OF STRUCTURE TO ENSURE STRUCTURAL LOADS ARE NOT TRANSMITTED TO FRAMES.
8. CAULK PERIMETER OF FRAMES. BETWEEN FRAME AND ADJACENT MATERIAL.
9. MAINTAIN CONTINUITY OF VAPOUR RETARDER.
10. PROVIDE EVEN MARGINS BETWEEN DOORS AND JAMBS AND DOOR FINISHED FLOOR AND THRESHOLDS AS FOLLOWS:
 - .1 HINGES SIDES: 1.0mm
 - .2 LATCHSIDE AND HEAD: 1.5mm
 - .3 FINISHED FLOOR AND THRESHOLDS: 13mm
11. ADJUST OPERABLE PARTS FOR CORRECT FUNCTION.
12. TOUCH UP WITH PRIMER FINISHES DAMAGED DURING INSTALLATION. FOLLOWING COMPLETION OF PRIMER APPLICATION, APPLY TWO (2) COATS OF EXTERIOR FINISH PAINT TO ALL DOOR SURFACES (COLOUR TO MATCH SIDING).
13. FILL EXPOSED FRAME ANCHORS SURFACES WITH IMPERFECTIONS WITH METALLIC PASTE FILLER AND SAND TO A UNIFORM SMOOTH FINISH.
14. INSTALL THREE (3) BUMPERS ON STRIKE JAMB FOR EACH DOOR.



A - INDICATES DETAIL NO.
B - INDICATED SHEET DETAIL IS REQUIRED
C - INDICATES SHEET DETAIL IS DRAWN

no.	revision	date	by	approved
2	REVISED	28/10/2020	MH	RB
1	ISSUED FOR CONSTRUCTION	16/11/2018	JS	RN
0	ISSUED FOR TENDER	18/06/20	JS	RN

Project - projet

MCTS GENERATOR BLDG
ST. LAWRENCE

Drawing - dessin

DOOR SCHEDULE AND DETAILS

drawn - dessiné	M.G.G.	designed - dessinée par	D.N.
date - date	AUGUST 2020	checked - vérifié	R.N.
scale - échelle	AS SHOWN	approved for tender - approuvé pour l'offre	R.N.
project no. - projet no.	drawing no. - no du dessin	sheet - feuille	
	01L1402B02905-A05	5 OF 16	

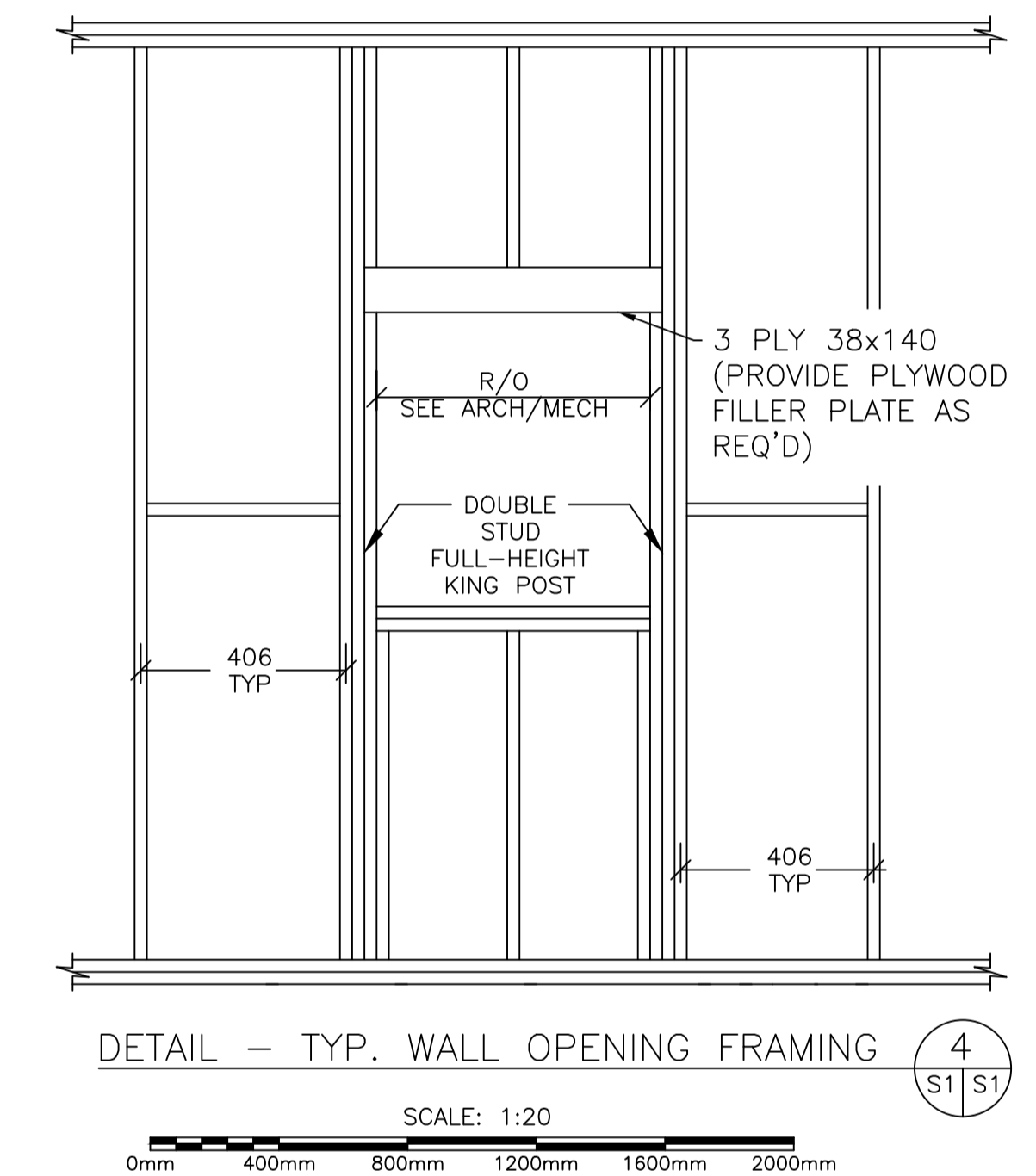
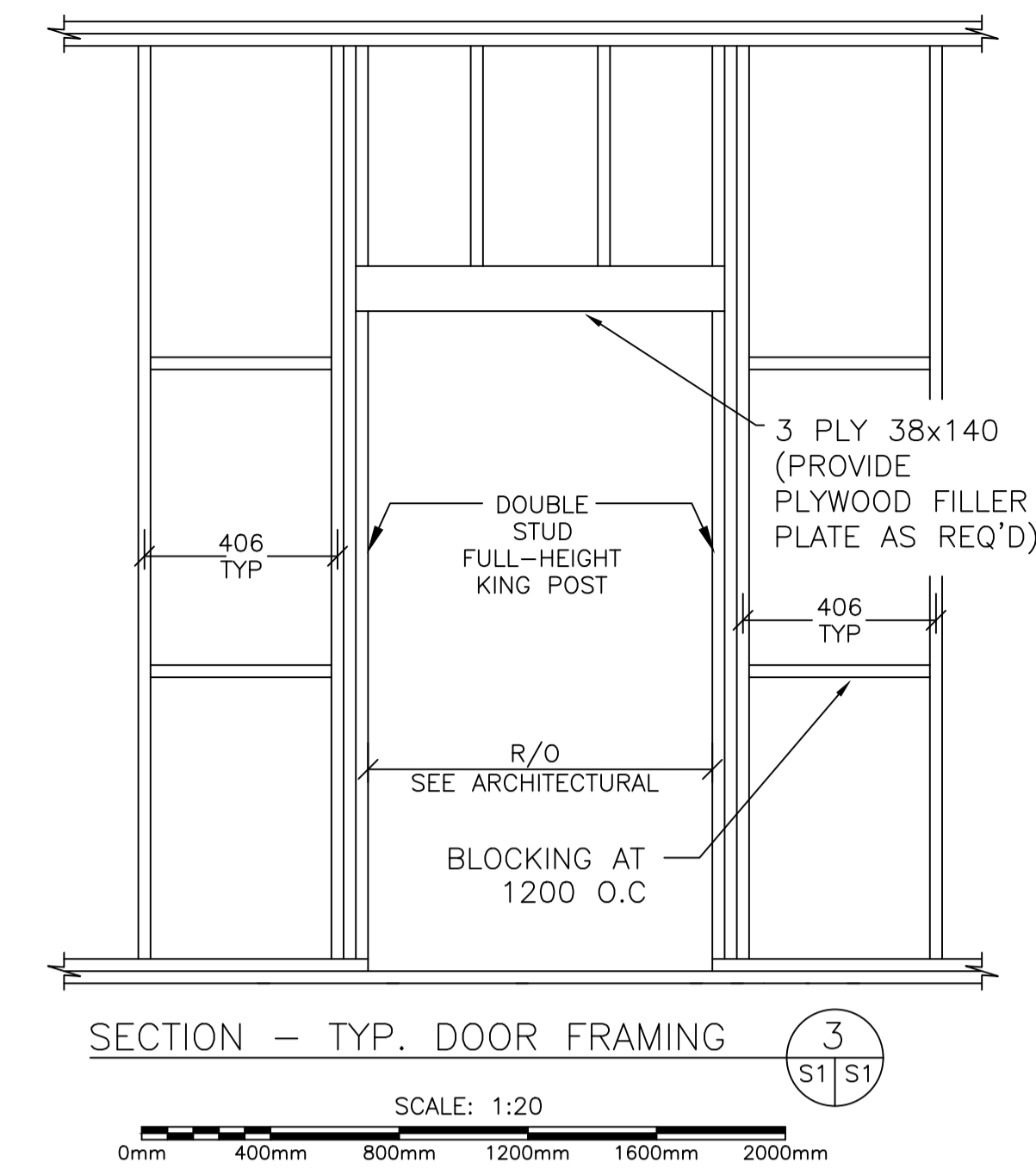
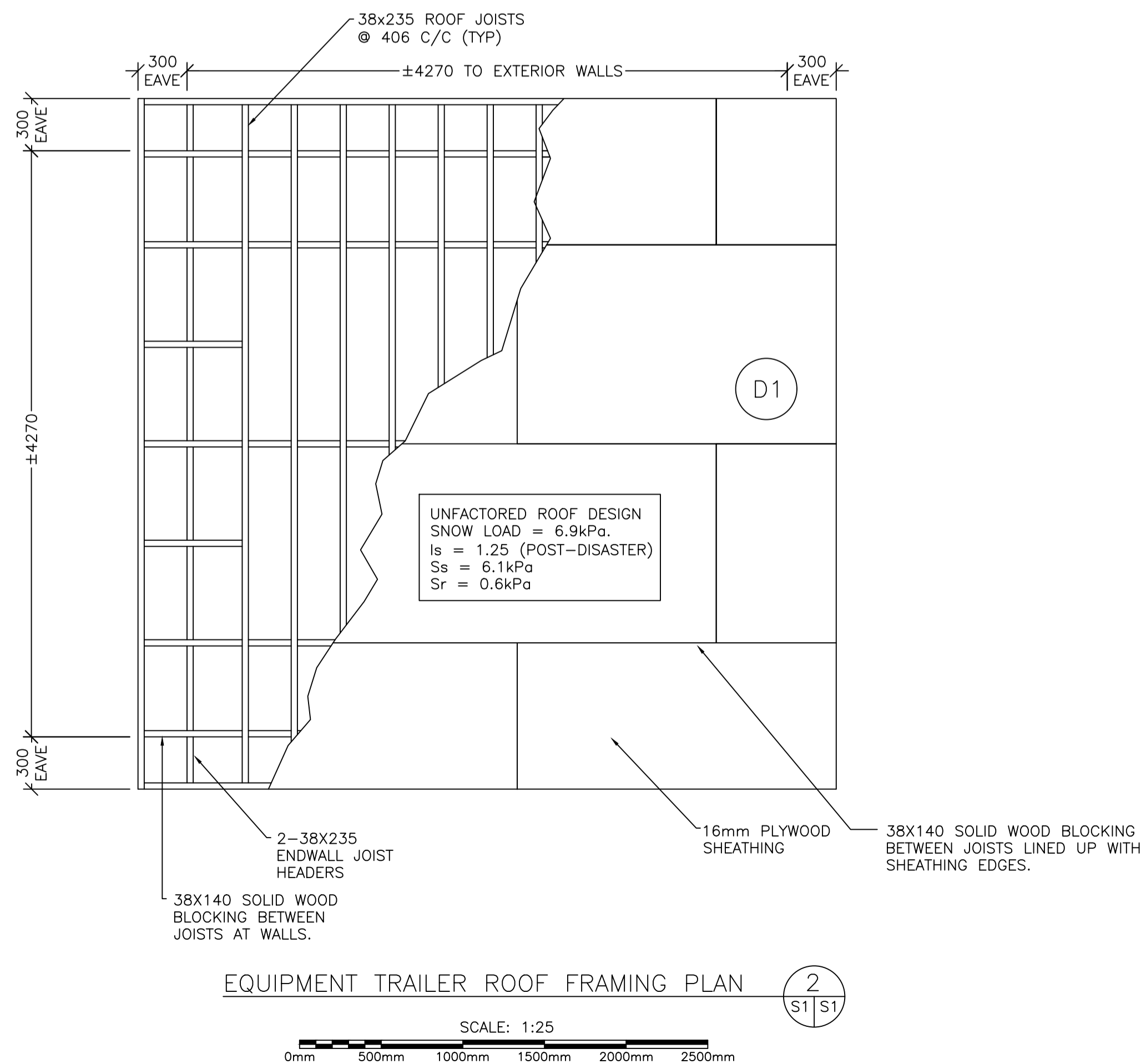
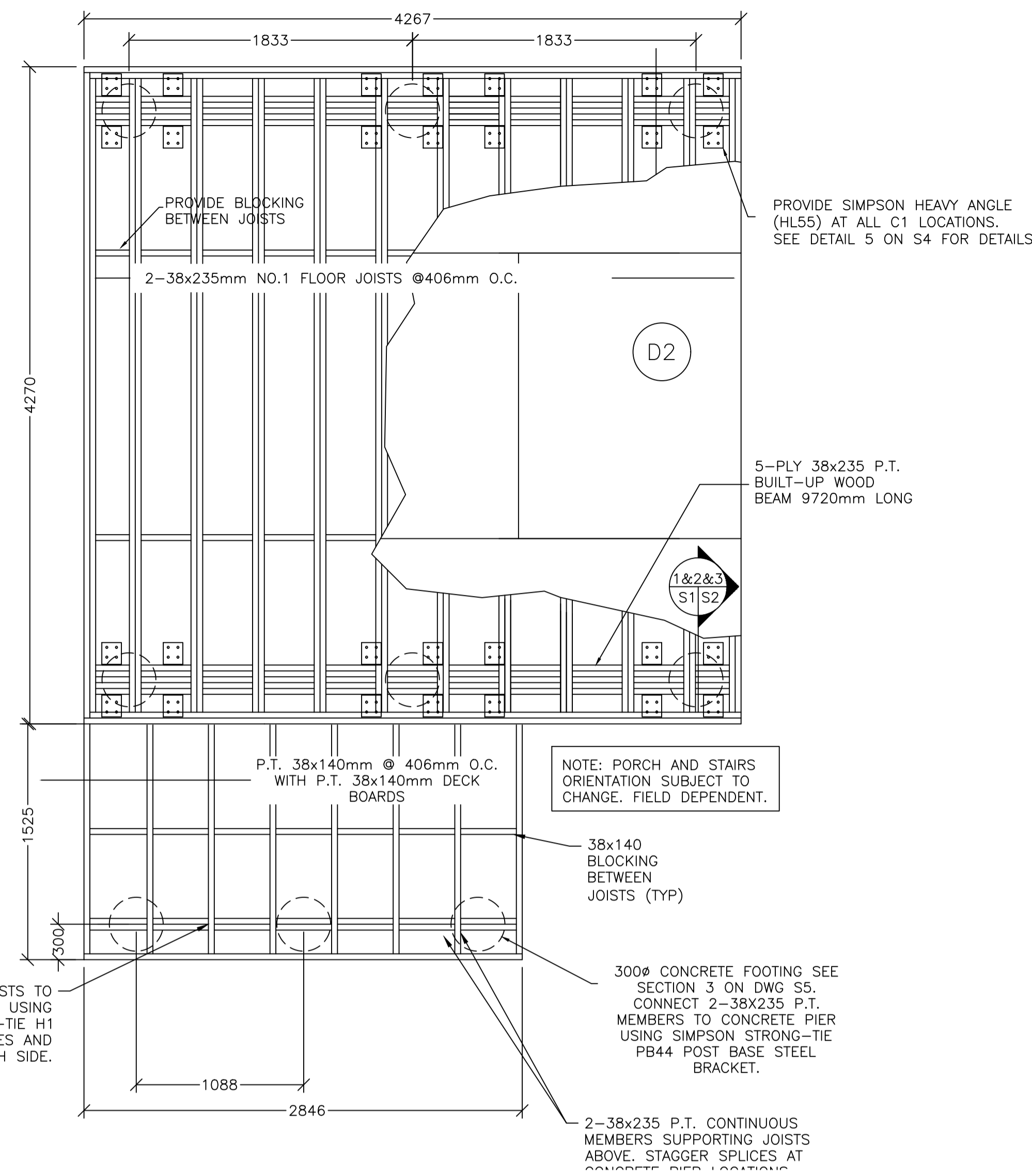

- STRUCTURAL TIMBER NOTES**
- ALL TIMBER MEMBERS (TRUSSES, JOISTS, GLUE LAMINATED, PLYWOOD, ETC.) TO BE DESIGNED IN ACCORDANCE WITH CSA 086 LATEST EDITION.
 - FABRICATOR SHALL SUBMIT SHOP DRAWINGS STAMPED BY A PROFESSIONAL ENGINEER REGISTERED IN THE PROVINCE OF NEWFOUNDLAND & LABRADOR PRIOR TO COMMENCEMENT OF FABRICATION.
 - WOOD JOISTS, BEAMS AND STUDS TO BE SPRUCE-PINE-FIR GRADE No.1/No.2
 - ALL SURFACES OF PRESSURE TREATED LUMBER THAT ARE EXPOSED THROUGH FIELD CUTTING, TRIMMING OR BORING MUST BE RE-TREATED WITH A LIBERAL APPLICATION OF PRESERVATIVE BEFORE INSTALLATION. INCISED LUMBER IS NOT PERMITTED.

PLYWOOD DIAPHRAGM SCHEDULE

MARK	DESCRIPTION
D1	16mm PLYWOOD SHEATHING (BLOCKED AT EDGES) NAILED TO FRAMING MEMBERS WITH 64mm NAILS AT 100 O.C. @ PANEL EDGES AND 300 O.C. OVER INTERMEDIATE FRAMING MEMBERS.
D2	19mm/13mm PLYWOOD SHEATHING (BLOCKED AT EDGES) NAILED TO FRAMING MEMBERS WITH 76mm NAILS AT 100 O.C. @ PANEL EDGES AND 300 O.C. OVER INTERMEDIATE FRAMING MEMBERS.

A - INDICATES DETAIL NO.
 B - INDICATED SHEET DETAIL IS REQUIRED
 C - INDICATES SHEET DETAIL IS DRAWN

no.	revision	date	by	approved
2	REVISED	28/10/2020	MH	RB
1	ISSUED FOR CONSTRUCTION	16/11/2018	JS	RN
0	ISSUED FOR TENDER	18/06/20	JS	RN

Project - projet
MCTS GENERATOR BLDG
ST. LAWRENCE

Drawing - dessin
FRAMING PLAN,
SECTIONS AND DETAILS

drawn - dessine	M.G.G.	designed - dessine par	R.N.
date - date	AUGUST 2020	checked - verifie	V.P.
scale - echelle	AS SHOWN	approved for tender - approuve pour l'offre	R.N.
project no. - projet no.	drawing no. - no du dessin	sheet - feuille	
	01L1402B02906-S01	6 OF 16	

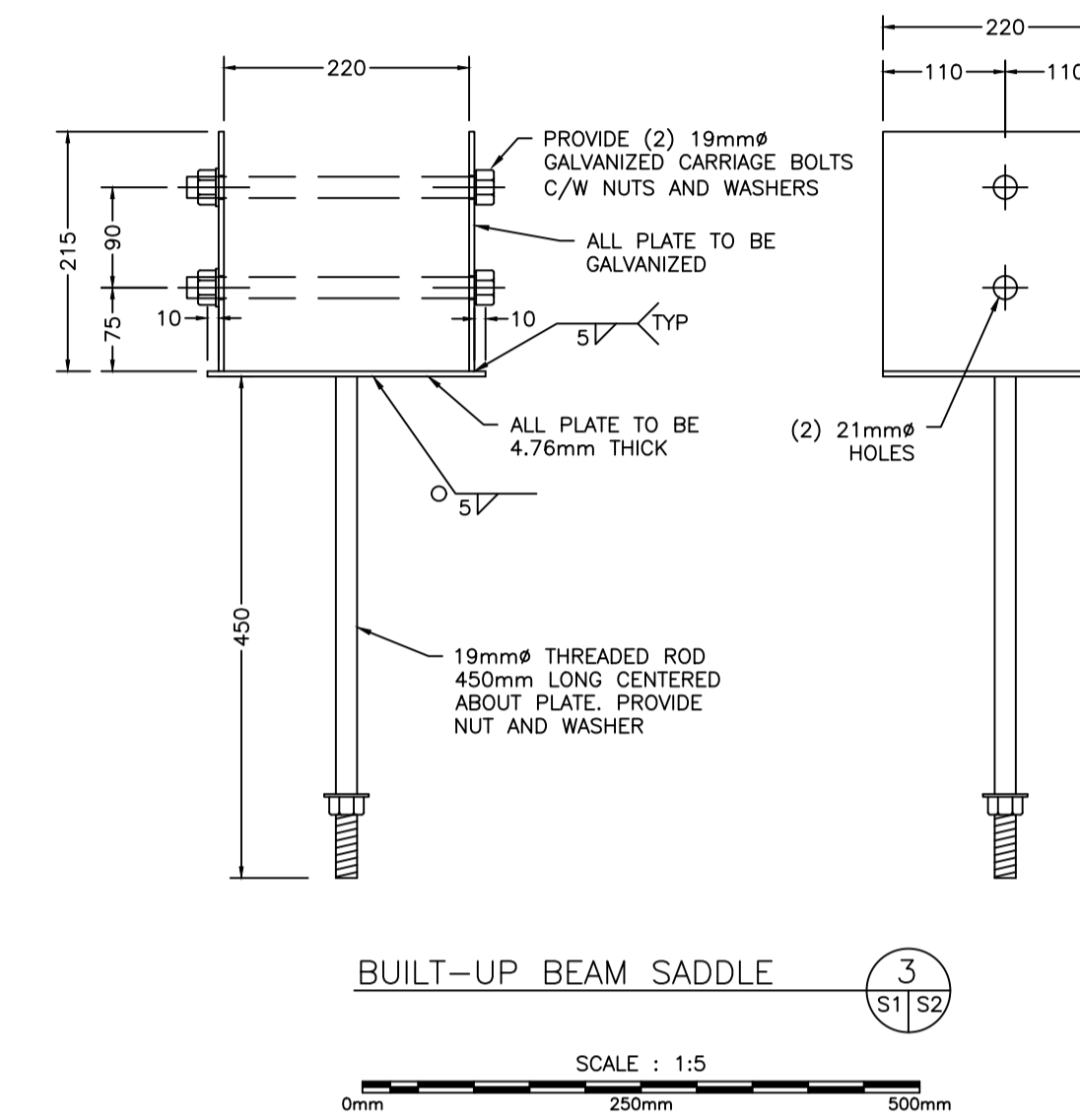
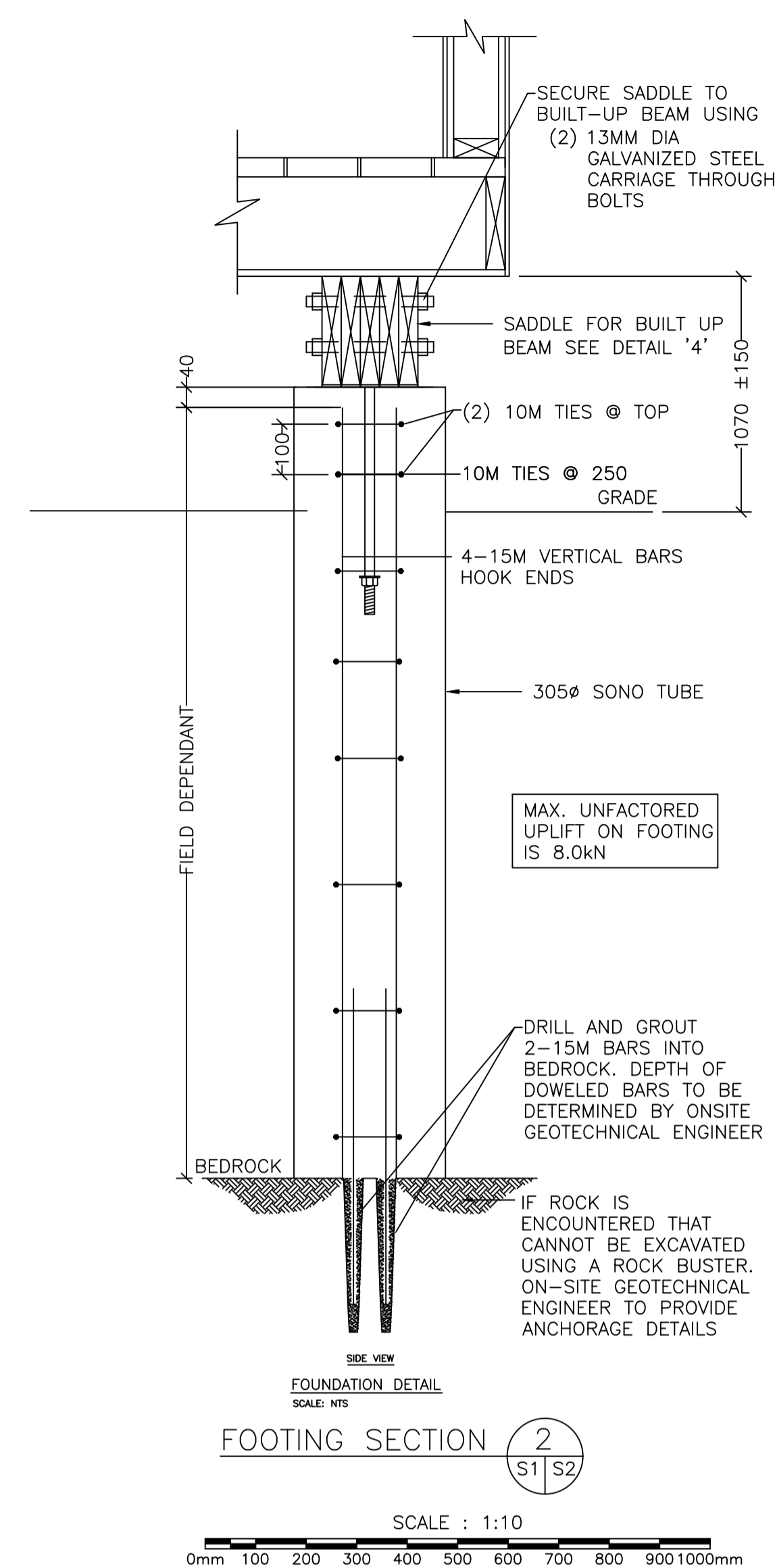
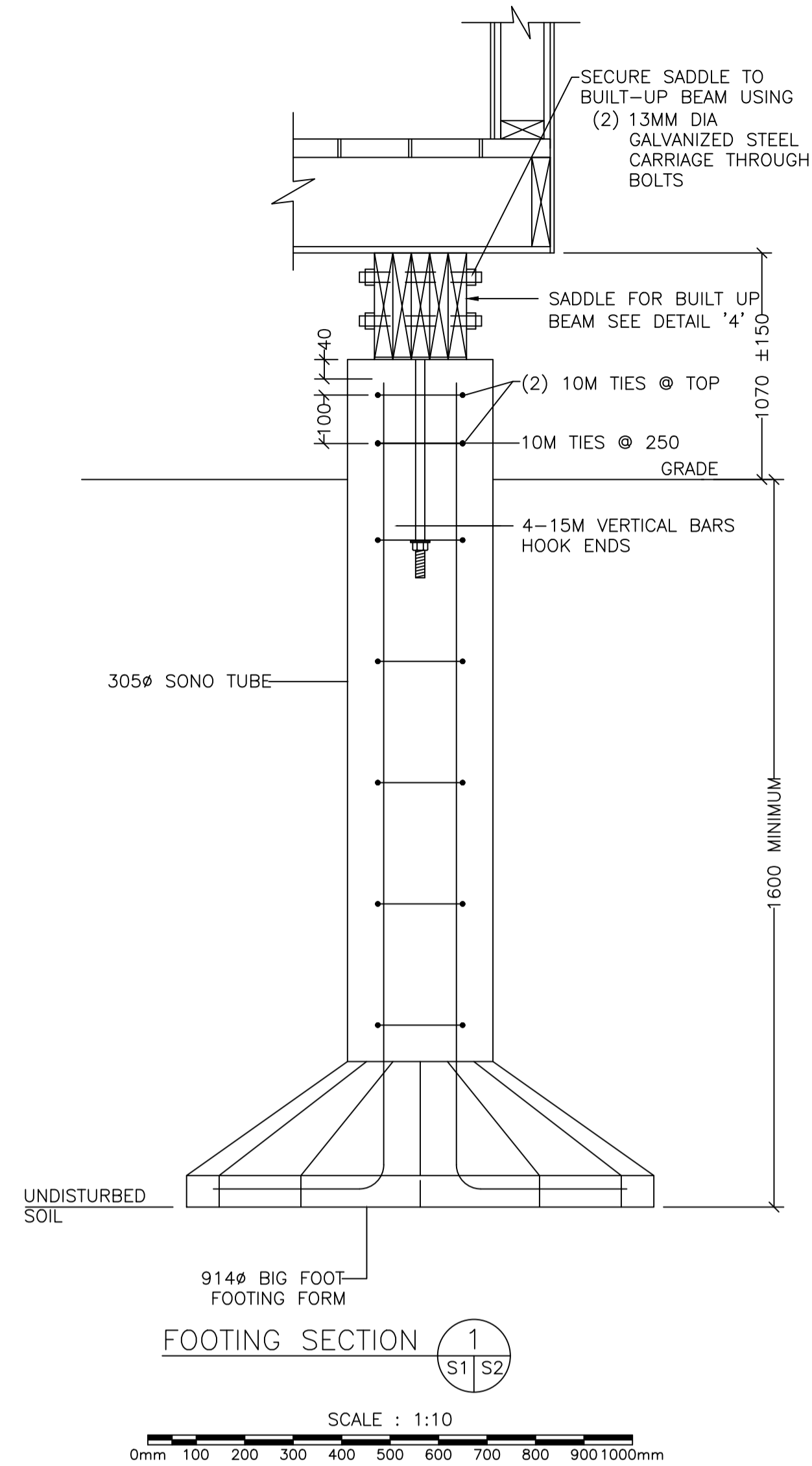

FOUNDATION NOTES

- ALL BEARING CAPACITIES AND SOIL CONDITIONS TO BE CONFIRMED BY A GEOTECHNICAL ENGINEER LICENSED TO PRACTICE IN THE PROVINCE OF NEWFOUNDLAND AND LABRADOR.
 - ALL FOOTINGS ARE TO REST ON UNDISTURBED TILL HAVING A MINIMUM BEARING CAPACITY OF 150 KPa U.N.O.
 - IF FOOTINGS REST ON COMPACTED BACK FILL, THEN ALL FOOTING ELEVATIONS ARE TO BE CONFIRMED BY A GEOTECHNICAL ENGINEER BEFORE POURING.
 - ANY SOFT SPOT ENCOUNTERED UNDER FOOTINGS SHALL BE REMOVED AND FILLED WITH MASS CONCRETE OF MIN 20 MPa TO U/S OF FOOTINGS.
 - THE UNDERSIDE OF COLUMN FOOTINGS SHALL BE AT LEAST 1600mm BELOW THE FINISHED GRADE U.N.O.
 - DO NOT PLACE FOOTINGS ON FROZEN GROUND.
- THE LINE OF SLOPE BETWEEN ADJACENT EXCAVATIONS FOR FOOTINGS OR TRENCHES OR ALONG STEPPED FOOTINGS SHALL NOT EXCEED 1 VERTICAL TO 1 HORIZONTAL. MAXIMUM STEP IS 750mm.
- BACKFILL MATERIALS
 - BACKFILL PROPERTIES TO THE FOLLOWING REQUIREMENTS:
 - CRUSHED, PIT RUN OR SCREENED STONE, GRAVEL OR SAND.
 - GRADATIONS TO BE WITHIN LIMITS SPECIFIED WHEN TESTED TO ASTM C136 AND ASTM C117. SIEVE SIZES TO CAN/CGSB.8.1.
 - BACKFILL AND FILL MATERIAL TO BE PLACED IN 300mm LIFTS.
- | SIEVE DESIGNATION | % PASSING |
|-------------------|-----------|
| 50.8 mm | 100 |
| 25.4 mm | 50-100 |
| 19 mm | - |
| 15.9 mm | - |
| 9.5 mm | - |
| 4.75 mm | 20-55 |
| 1.20 mm | 10-35 |
| .30 mm | 5-20 |
| 0.075 mm | 2-8 |
- DO NOT BACKFILL AROUND OR OVER CAST-IN-PLACE CONCRETE WITHIN 48 h AFTER PLACING CONCRETE.
 - PLACE BACKFILL LAYERS SIMULTANEOUSLY ON BOTH SIDES OF INSTALLED WORK TO EQUALIZE LOADING. DIFFERENCE NOT TO EXCEED 300mm.
 - COMPACTION UNDER FOOTINGS TO 98% STANDARD PROCTOR DENSITY.
 - DEWATER EXCAVATIONS TO ENSURE CONCRETE AND SERVICES ARE PLACED IN THE DRY.
 - PROTECT EXISTING BUILDING AND SURFACE FEATURES FROM DAMAGE WHILE WORK IS IN PROGRESS. IN THE EVENT OF DAMAGE, IMMEDIATELY MAKE REPAIR TO APPROVAL OF ENGINEER.

CAST IN PLACE CONCRETE NOTES

- ALL CONCRETE PRODUCTION AND PLACEMENT INCLUDING WEATHER PROTECTION TO CONFORM TO CSA A23.1 LATEST EDITION. ALL TESTING TO CONFORM TO CSA 23.2 LATEST EDITION.
- ALL CONCRETE SHALL HAVE A MINIMUM COMPRESSIVE STRENGTH OF 32 MPa U.N.O. FOOTINGS/PIERS: 32 MPa, MAXIMUM SLUMP 75mm, EXPOSURE CLASS F-2
- CLEAR CONCRETE COVER TO REINFORCING PER CSA A23.1:

FOOTINGS:	75mm
PIERS:	50mm
- ALL REINFORCING TO CONFORM TO CSA G30.18 LATEST EDITION. ALL REINFORCING TO HAVE A MINIMUM YIELD OF 400 MPa.
- ALL REINFORCING STEEL SHALL BE DETAILED, FABRICATED AND SUPPORTED IN ACCORDANCE WITH CSA A23.1 LATEST EDITION.
- ALL DOWELS ARE TO BE TIED TO VERTICAL REBAR AND IN PROPER POSITION BEFORE POURING CONCRETE. PLACING DOWELS AFTER CONCRETE IS POURED IS UNACCEPTABLE.
- FORM WORK MUST NOT BE REMOVED UNTIL CONCRETE HAS ATTAINED SUFFICIENT STRENGTH TO SUSTAIN ALL LOADINGS.
- LAP SPLICE ALL FOOTING DOWELS CLASS "B" TENSION SPLICE TO VERTICALS IN PIERS AND WALLS. ALL OTHER OTHER REINFORCING STEEL SHALL BE LAPPED A MINIMUM OF 24 BAR DIAMETERS, 300mm MIN U.N.O.
- SUBMIT SHOP DRAWINGS ON ALL CONCRETE ANCHORS. CONCRETE ANCHORS TO BE INSTALLED TO AVOID EXISTING REBAR.
- SUBMIT REINFORCING STEEL SHOP DRAWINGS FOR REVIEW BY ENGINEER PRIOR TO FABRICATION OF REINFORCING.



A - INDICATES DETAIL NO.
 B - INDICATED SHEET DETAIL IS REQUIRED
 C - INDICATES SHEET DETAIL IS DRAWN

no.	revision	date	by	approved
2	REVISED	28/10/2020	MH	RB
1	ISSUED FOR CONSTRUCTION	16/11/2018	JS	RN
0	ISSUED FOR TENDER	18/06/20	JS	RN

Project - projet

**MCTS GENERATOR BLDG
ST. LAWRENCE**

Drawing - dessin

**FOUNDATIONS
SECTIONS AND DETAILS**

drawn - dessine	M.G.G.	designed - dessine par	R.N.
date - date	AUGUST 2020	checked - verifie	V.P.
scale - echelle	AS SHOWN	approved for tender - approuve pour l'offre	R.N.
project no. - projet no.	drawing no. - no du dessin	sheet - feuille	
	01L1402B02907-S02	7 OF 16	

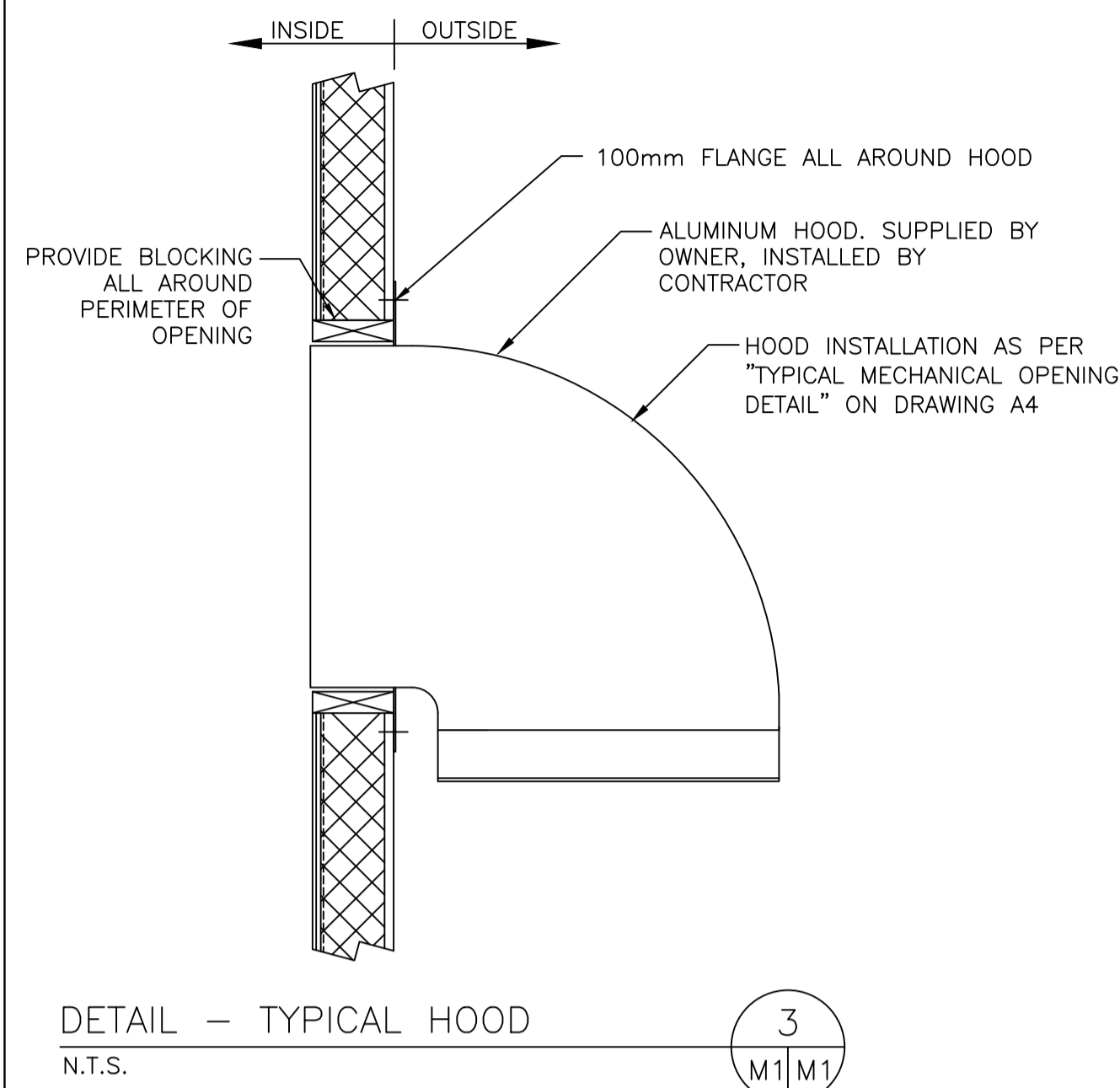

GAS DETECTOR SUITABLE FOR MONITORING OF FLAMMABLE, TOXIC AND OXYGEN GAS HAZARDS. MONITOR TO BE HONEYWELL SENSEPOINT XCD OR APPROVED EQUAL. OWNER SUPPLY & INSTALL.

PURPOSE MADE ALUMINUM ENGINE COOLING EXHAUST HOOD THE FULL SIZE OF RAD CONNECTION. SEE TYPICAL DETAIL THIS SHEET. OWNER SUPPLIED, CONTRACTOR INSTALLED.

SIZE OF EXHAUST HOOD TO BE EQUIVALENT 850x850 TO SUIT

DIMENSIONS CONFIRMING LOCATION OF 3 CONDUITS IN FLOOR FROM GENERATOR TO TRANSFER SWITCH TO BE FIELD COORDINATED WITH OWNER.

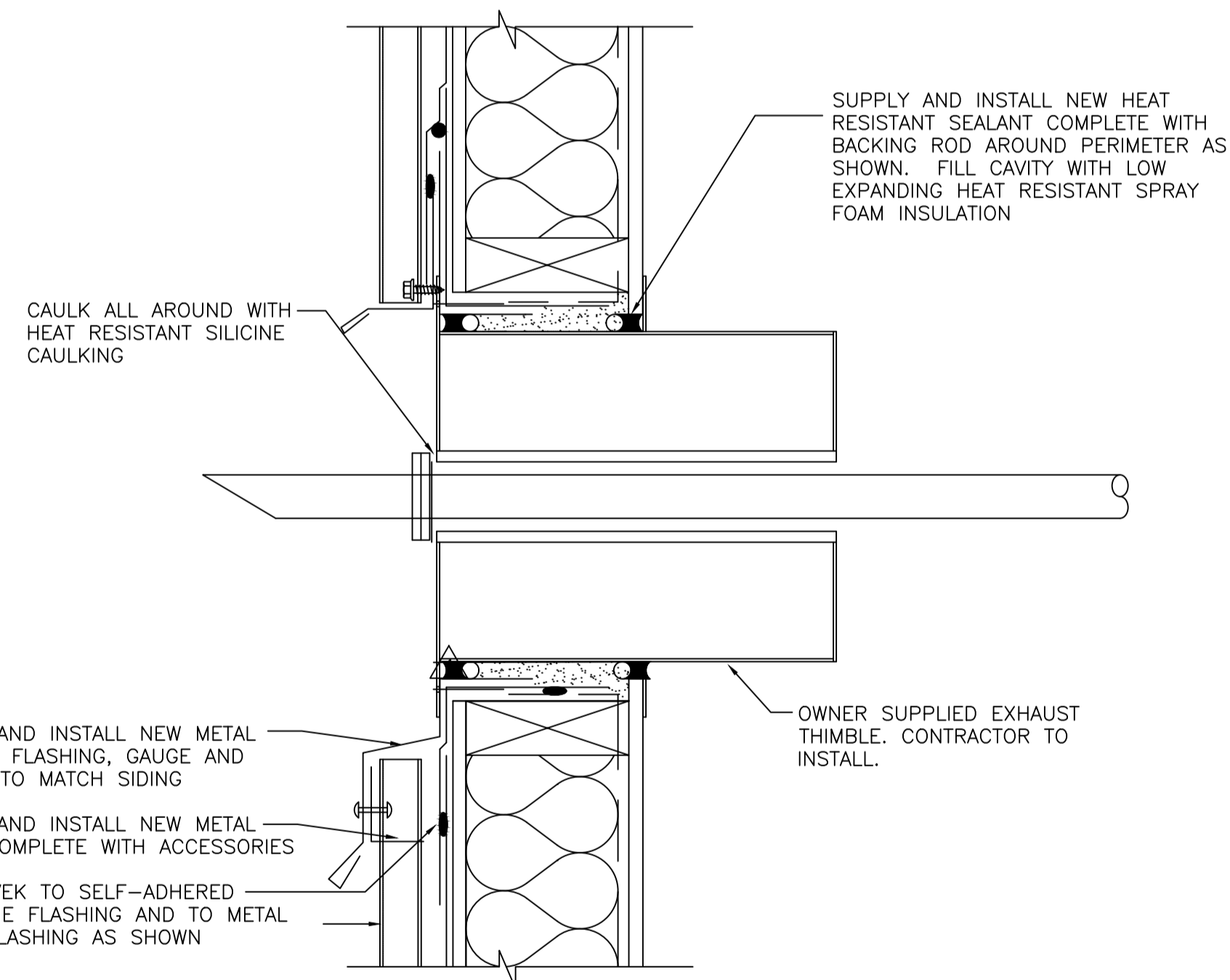
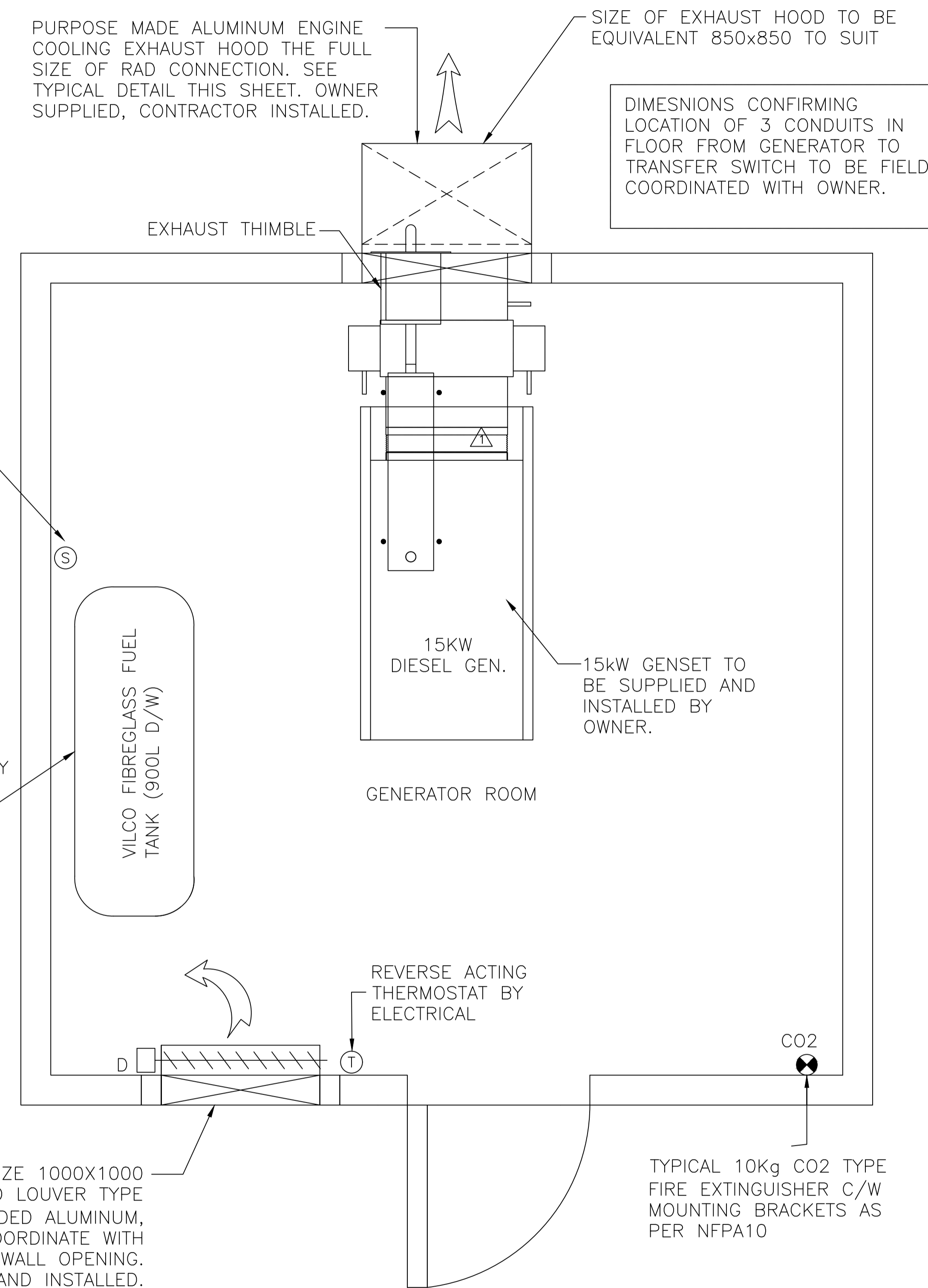

INTAKE AIR LOUVER SIZE 1000X1000 OR EQUIVALENT. FIXED LOUVER TYPE "AIROLITE" K6776, EXTRUDED ALUMINUM, 150mm DEPTH. COORDINATE WITH ARCH. STRUCTURAL FOR WALL OPENING. CONTRACTOR SUPPLIED AND INSTALLED.

TYPICAL 10kg CO2 TYPE FIRE EXTINGUISHER C/W MOUNTING BRACKETS AS PER NFPA10

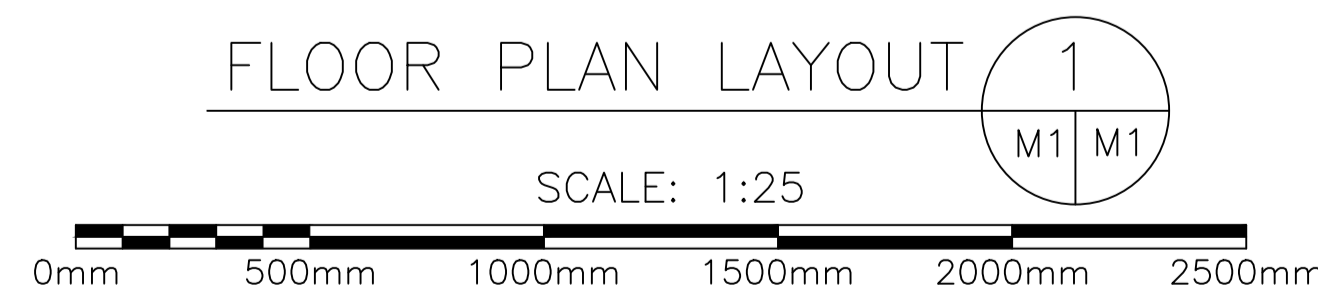
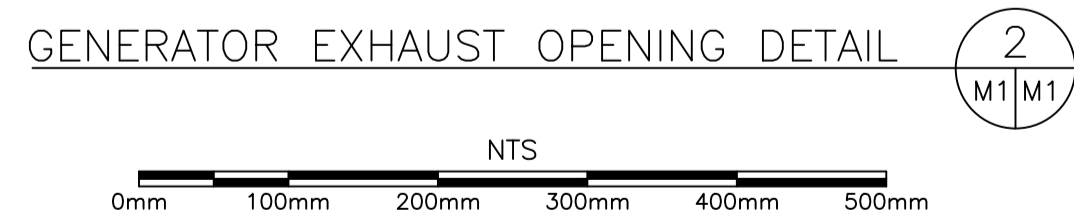

A - INDICATES DETAIL NO.
 B - INDICATED SHEET DETAIL IS REQUIRED
 C - INDICATES SHEET DETAIL IS DRAWN

2	REVISED	28/10/2020	MH	RB
1	ISSUED FOR CONSTRUCTION	16/11/2018	JS	RN
0	ISSUED FOR TENDER	18/06/20	JS	RN
no. no	revision	date	by	approved
	revision	date	par	approve

Project - projet
MCTS GENERATOR BLDG
ST. LAWRENCE

Drawing - dessin
PLANS AND DETAILS

drawn - dessine	M.G.G.	designed - dessine par	T.T.
date - date	AUGUST 2020	checked - verifie	J.H.
scale - echelle	AS SHOWN	approved for tender - approuve pour l'offre	R.N.
project no. - projet no.	drawing no. - no du dessin	sheet - feuille	
	01L1402B02908-M01	8 OF 16	

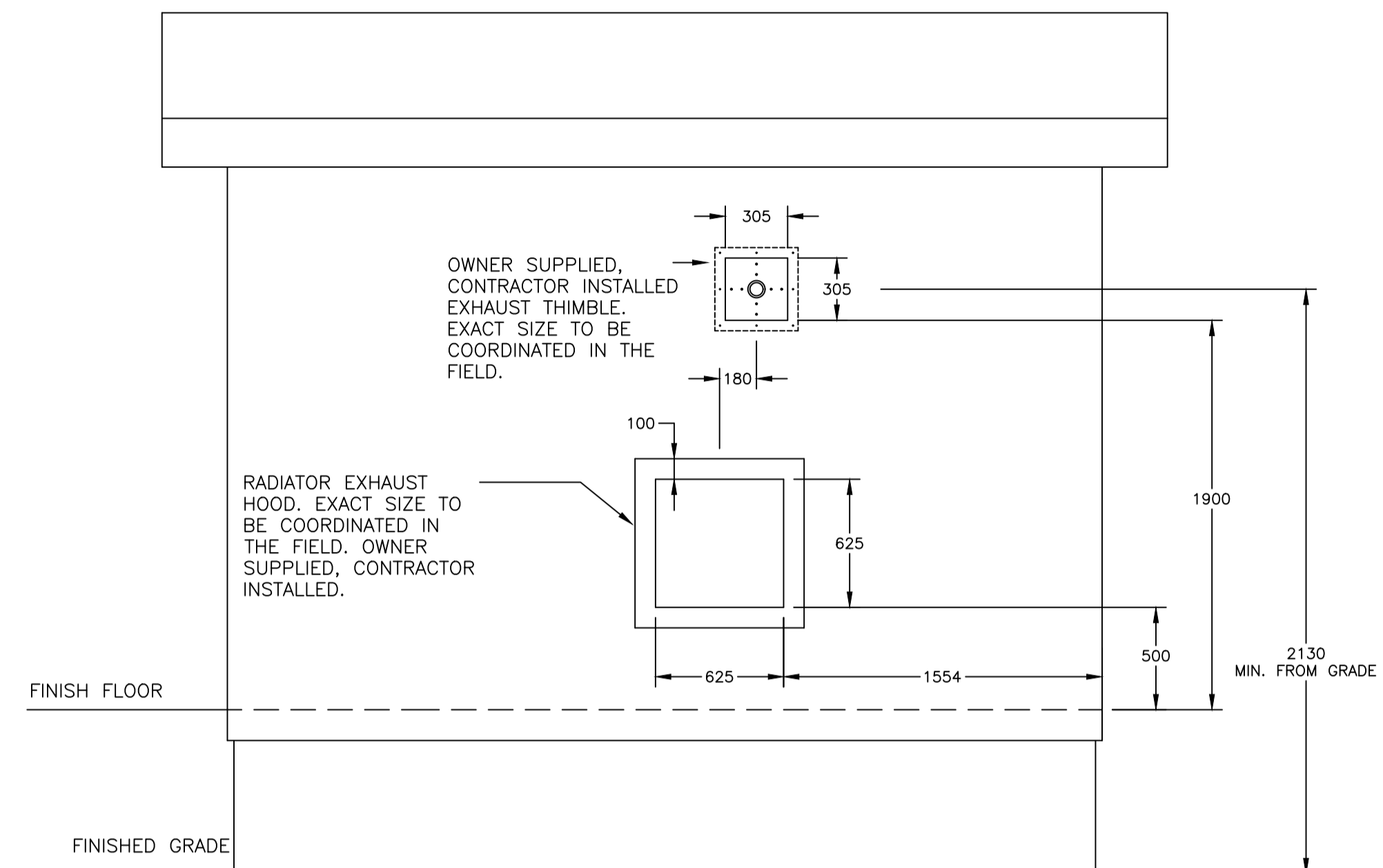

REAR ELEVATION 1

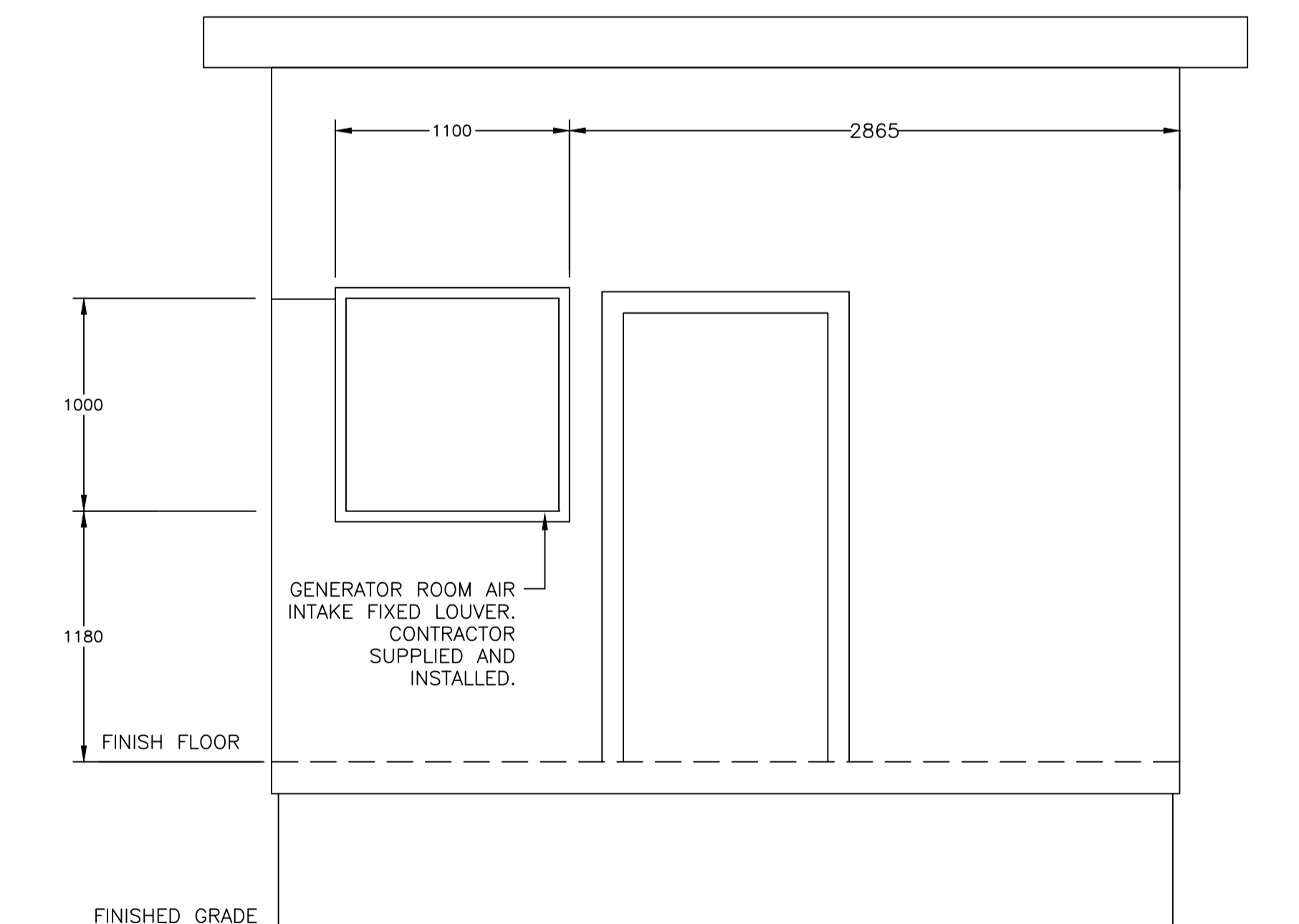
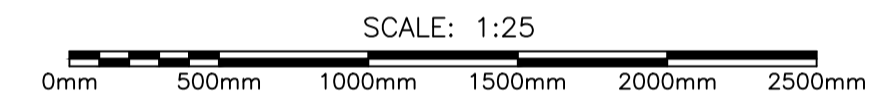

FRONT ELEVATION 2



A - INDICATES DETAIL NO.
 B - INDICATED SHEET DETAIL IS REQUIRED
 C - INDICATES SHEET DETAIL IS DRAWN

no.	revision	date	by	approved
2	REVISED	28/10/2020	MH	RB
1	ISSUED FOR CONSTRUCTION	16/11/2018	JS	RN
0	ISSUED FOR TENDER	18/06/20	JS	RN

Project - projet

MCTS GENERATOR BLDG
ST. LAWRENCE

Drawing - dessin

MECHANICAL PENETRATIONS

drawn - dessine	M.G.G.	designed - dessine par	T.T.
date - date	AUGUST 2020	checked - verifie	J.H.
scale - echelle	AS SHOWN	approved for tender - approuve pour l'offre	R.N.
project no. - projet no.	drawing no. - no du dessin	sheet - feuille	
	01L1402B02909-M02	9 OF 16	

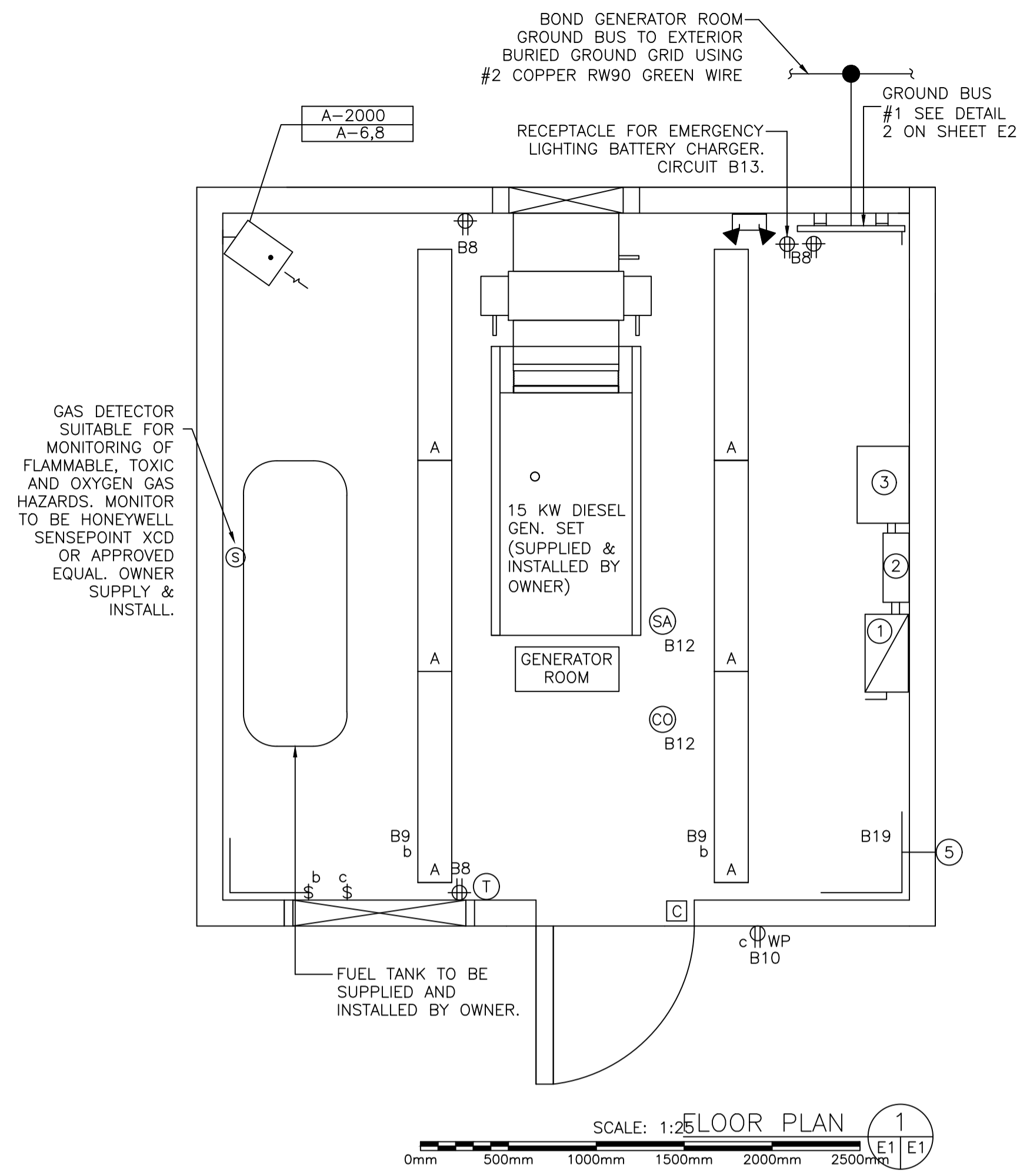

EQUIPMENT DESCRIPTION

- ① MAIN SERVICE ENTRANCE DISCONNECT SWITCH 200A/200AF, 120/240V. 1Ø, 2P, SOLID NEUTRAL, BY SQUARE-D / SCHNEIDER ELECTRIC.
- ② MAIN DISTRIBUTION PANEL BOARD DP-A 200A. 120/240V. 1Ø, 3W. SEE PANEL DETAIL.
- ③ AUTOMATIC TRANSFER SWITCH. OWNER SUPPLIED, CONTRACTOR INSTALLED.
- ④ EMERGENCY DISTRIBUTION PANEL BOARD EP-B 100A. 120/240V. 1Ø, 3W. SEE PANEL DETAIL.
- ⑤ TWO COMPARTMENT WIREWAY AROUND FULL PERIMETER OF EQUIPMENT ROOM. LOCATE IN UPPER CORNER OF WALL AS PER DETAIL 3, SHEET E2. WIREWAY TO BE USED FOR WIRING OF DEVICES SHOWN IN EQUIPMENT ROOM. WIREWAY TO BE HOOKED UP TO PANEL EP-B.

LEGEND

- \$ — SINGLE POLE SWITCH 120V. 15A. #PS15AC1-1 BY PASS & SEYMOUR, INSTALLED IN SURFACE MOUNTED BOX #CIFS-1G-1/2 WITH #CIFS-9 COVER BY THOMAS & BETTS. INDICATES LIGHTS CONTROLLED
- # — GANGED TOGGLE SWITCHES
- ⊕ — DUPLEX OUTLET 15A. 120V. #5262-1 BY PASS & SEYMOUR, INSTALLED IN SURFACE MOUNTED BOX #CIFS-1G-1/2 WITH #CDR COVER BY THOMAS & BETTS.
- ⊕ — SAME AS ABOVE EXCEPT MOUNTED 1050MM ABOVE FINISHED FLOOR.
- ▼ — TELEPHONE OUTLET.
RUN TELEPHONE WIRING IN 21MM EMT CONDUIT TO TELEPHONE EQUIPMENT
- ↔ — EMERGENCY LIGHTING UNIT. 120V AC. C/W 2 - 12VOLT 6W LED MR16 LAMP HEADS. MOUNT 2100MM AFF. PROVIDE L5-15R ADJACENT RECEPTACLE TEST SWITCH. SERIES #12ESL144-2-LJ BY EMERGI-LITE.
- ↔ — DOUBLE ADJUSTABLE REMOTE HEAD FOR EMERGENCY LIGHTING. 12 VOLT 5W LED MR16. MOUNT 2100MM AFF. RUN 2 #12 RW90 IN 21mm CONDUIT TO EMERGENCY LIGHTING UNIT. SERIES #EF150-D-LIC BY EMERGI-LITE.
- ☐ — ELECTRIC UNIT HEATER. SUSPENDED UNIT HEATER 2000W. 240V. 1Ø #OAS2038 BY OUELLET.
- Ⓞ — GAS DETECTOR. SEE MECHANICAL DRAWINGS FOR DETAIL.
- Ⓣ — LOW VOLTAGE VICONICS VT7200 THERMOSTAT. SUPPLIED & INSTALLED BY DIV. 26.
- Ⓣ — LOW VOLTAGE HONEYWELL FOCUS PRO 5000 THERMOSTAT. SUPPLIED & INSTALLED BY DIV. 26.
- Ⓢ — SMOKE ALARM AMERICAN SENSORS ESA5011 C/W RM3A RELAY MODULE. TIE INTO SECURITY SYSTEM. REFER TO DETAILS 3 & 5 ON DWG E2. (INTERCONNECT SMOKE ALARMS SUCH THAT WHEN ONE SOUNDS THEY ALL SOUND.)
- Ⓞ — CARBON MONOXIDE RELAY.
- Ⓢ — CONNECTION TO MECHANICAL OR ELECTRICAL EQUIPMENT
- Ⓞ — CARBON MONOXIDE ALARM. KIDDE#900-0L20 C/W RM3A RELAY MODULE. TIE INTO SECURITY SYSTEM. REFER TO DETAILS 3 & 5 ON DRAWING E2.
- ☐ — SURFACE MOUNTED 1.22m LONG 42W LED LUMINAIRE C/W ENERGY EFFICIENT 120V ELECTRIC DRIVER, FROST ACRYLIC LENS AND END CAP. 5000 LUMEN OUTPUT, 4000K CCT, MIN. CRI 80. LITHONIA CAT. #Z1DL485000LMFST12040KPLRWH OR APPROVED EQUAL.
- Ⓞ — EXTERIOR WALL MOUNTED LED LUMINAIRE WITH PHOTOCELL CONTROL, IMPACT RESISTANT POLYCARBONATE LENS, 120V, 19W, 1070 LUMENS, 5000K CCT. LITHONIA CATALOG #TWSLED-1-50K-120-PE OR APPROVED EQUAL.
- Ⓜ — PROVIDE CSA TYPE 3 (NEMA 3) RATED OUTDOOR JUNCTION BOX FOR CONNECTION TO A/C UNITS. PROVIDE 2#10 + 1#10 GND FOR EACH OUTDOOR A/C UNIT IN 21mmC FROM PANEL B TO THE JUNCTION BOX AND LEAVE 300mm OF COILED WIRE IN THE JUNCTION FOR CONNECTION TO A/C UNITS BY A/C CONTRACTOR. EXACT LOCATION OF JUNCTION BOX TO BE DETERMINED IN THE FIELD. SIZE JUNCTION BOX PER CEC.
- ☐ — ELECTRIC BASEBOARD HEATER. 7 FOOT LONG, 3750W, 240V. DOUBLE 20A BREAKER FOR 3750W OF HEAT.
- Ⓢ — EMERGENCY STOP SWITCH TIED BACK TO AUTOMATIC TRANSFER SWITCH IN GENERATOR ROOM.

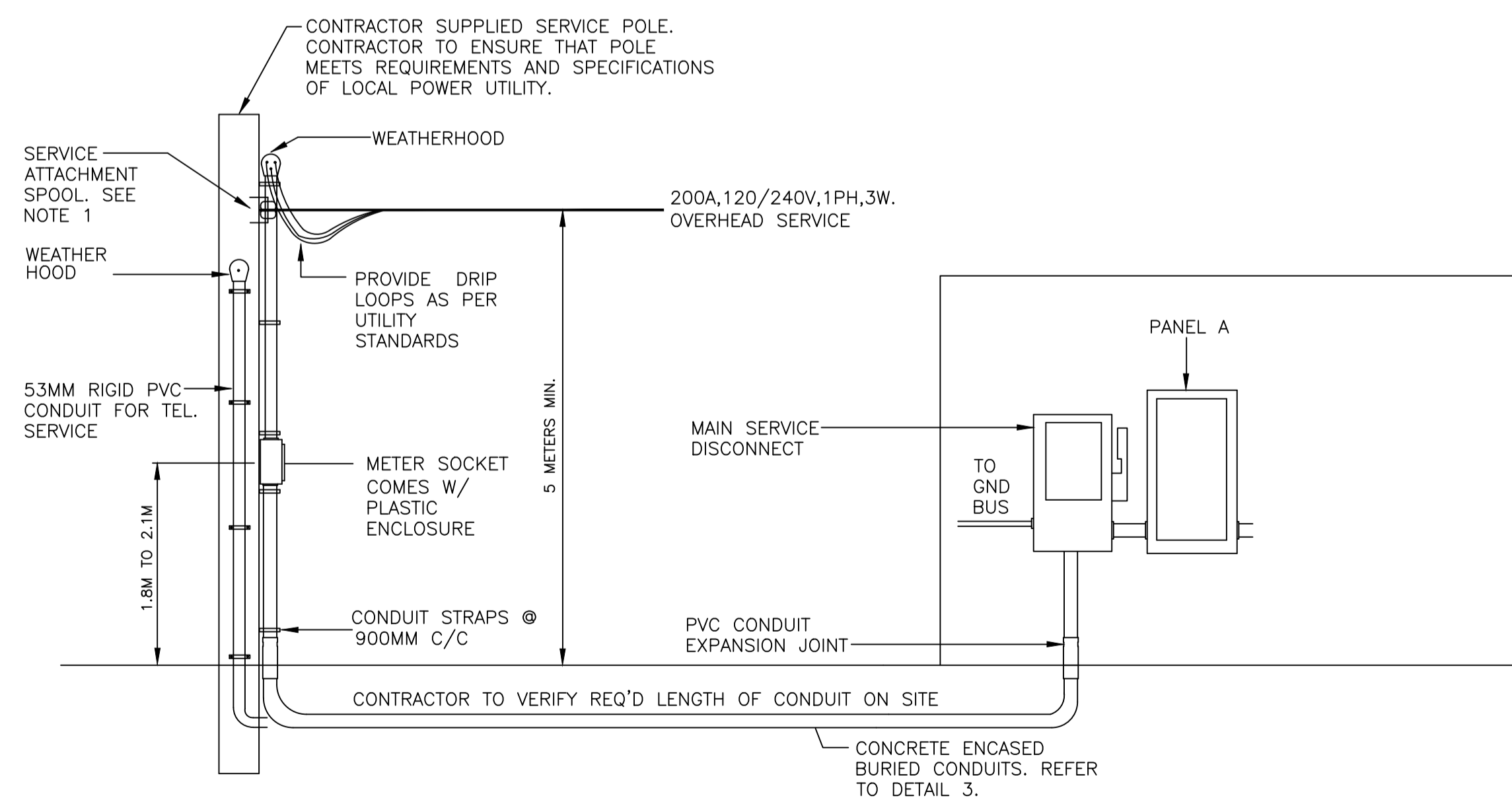

- NOTES**
1. SERVICE ATTACHMENT SPOOL SHALL BE LOCATED NOT LESS THAN 4.5M ABOVE GRADE AS PER CEC.
 2. SERVICE INSTALLATION SHALL BE AS PER CEC AND UTILITY STANDARDS.

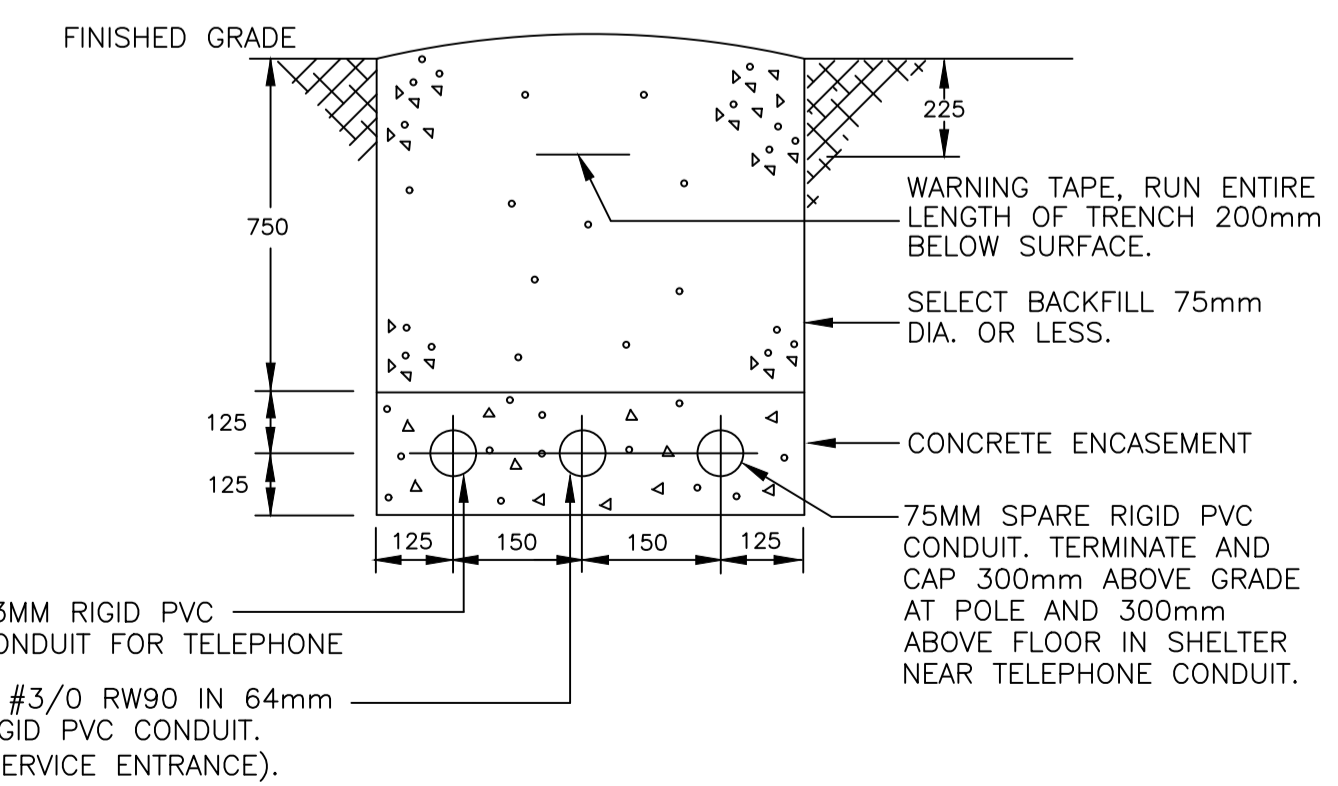

A - INDICATES DETAIL NO.
 B - INDICATED SHEET DETAIL IS REQUIRED
 C - INDICATES SHEET DETAIL IS DRAWN

2	REVISED	28/10/2020	MH	RB
1	ISSUED FOR CONSTRUCTION	16/11/2018	JS	RN
0	ISSUED FOR TENDER	18/06/20	JS	RN
no. no.	revision revision	date date	by par	approved approve

Project - projet

MCTS GENERATOR BLDG ST. LAWRENCE

Drawing - dessin

ELECTRICAL LAYOUT AND LEGEND

drawn - dessine	M.G.G.	designed - dessine par	K.W.
date - date	AUGUST 2020	checked - verifie	D.C.
scale - echelle	AS SHOWN	approved for tender - approuve pour l'offre	R.N.
project no. - projet no.	drawing no. - no du dessin	sheet - feuille	
	01L1402B02910-E01	10 OF 16	

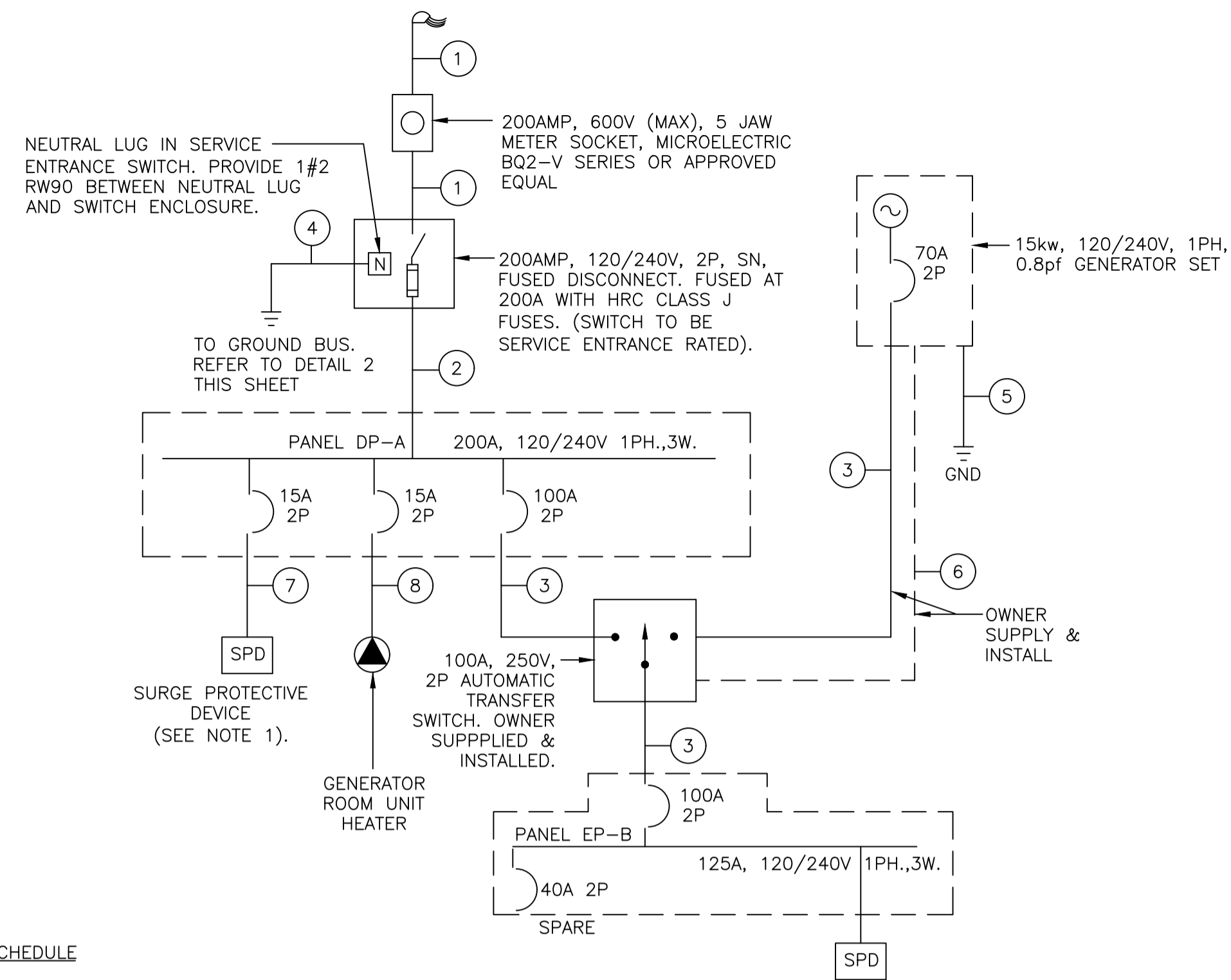

FEEDER SCHEDULE

- ① - UTILITY TO BE COMPLETED AS PART OF THIS CONTRACT. 3 #3/0 XLPE.
 - ② - 3 #3/0 RW90 +GND IN 53mm CONDUIT.
 - ③ - 3 #3 RW90 + GND IN 35mm CONDUIT.
 - ④ - 1 #2 RW90 GND IN 27mm CONDUIT.
 - ⑤ - 1 #6 RW90 GND IN 21mm CONDUIT.
 - ⑥ - 6 #12 RW90 + GND STRANDED IN 21mm CONDUIT.
 - ⑦ - WIRE SUPPLIED WITH SPD. MOUNT SPD ON THE PANEL ENCLOSURE AND RUN WIRE AS STRAIGHT AS POSSIBLE TO THE DOUBLE 30A SPD BREAKER. WIRE LENGTH FROM SPD TO BREAKER SHALL NOT EXCEED 150mm
 - ⑧ - 150mm
1. SURGE PROTECTIVE DEVICE TO BE OWNER SUPPLIED AND INSTALLED.
2. TRANSFER SWITCH (OWNER SUPPLIED, CONTRACTOR INSTALLED) HAS A SWITCHED NEUTRAL. BOND NEUTRAL TO GROUND AT THE GENERATOR.

SINGLE LINE DIAGRAM
N.T.S.

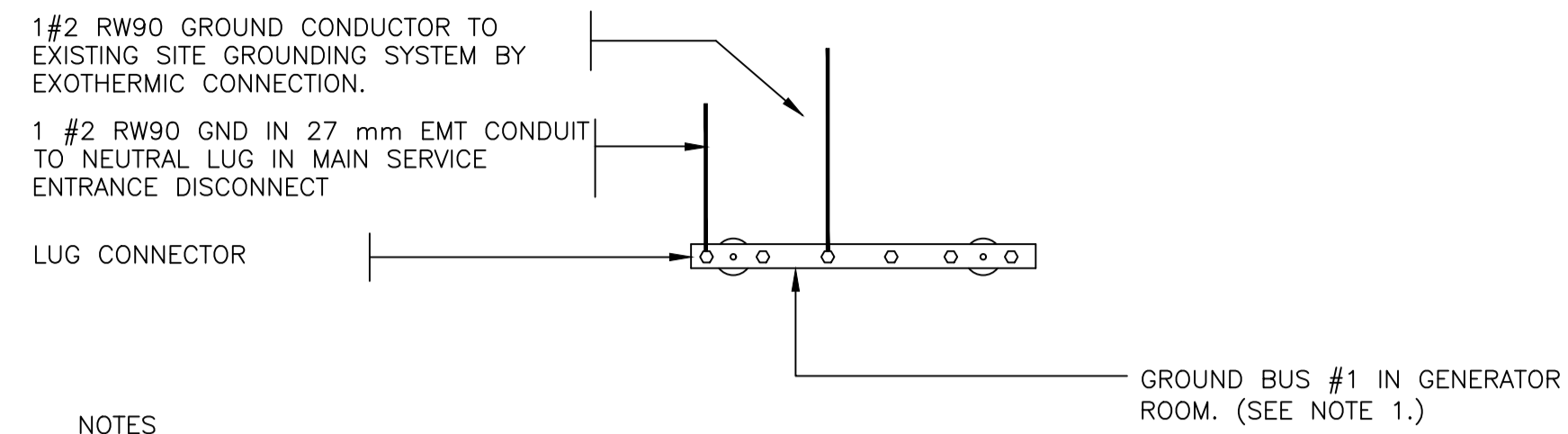

NOTES

1. GROUND BUSES SHALL BE ANDREW COMMSCOPE CAT.# UGBKIT-0424. INSTALL AS PER MANUFACTURER'S INSTRUCTIONS.

GROUND BUS DETAIL
N.T.S.

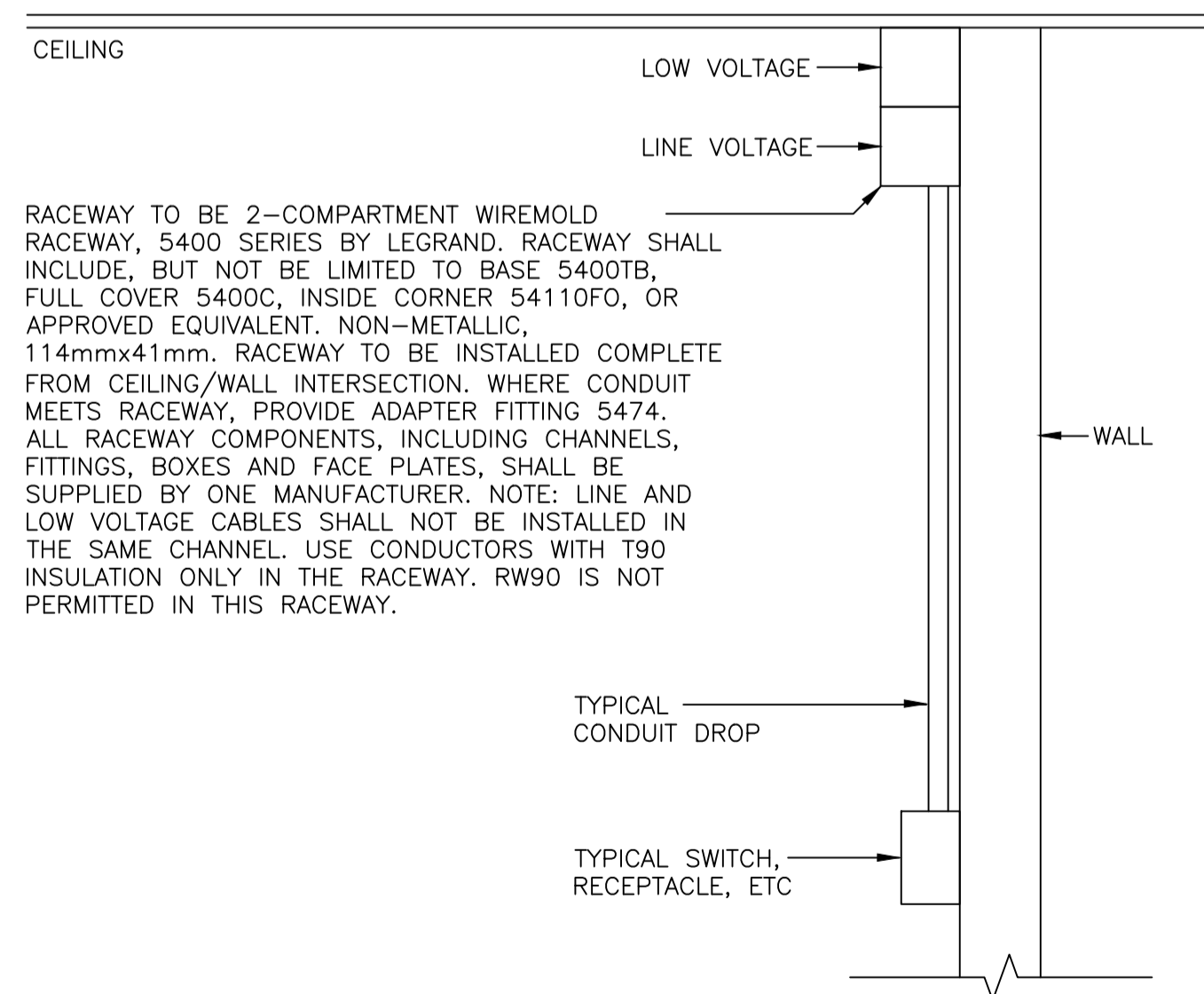

PERIMETER WIREWAY DETAIL
N.T.S.

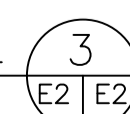

- A - INDICATES DETAIL NO.
B - INDICATED SHEET DETAIL IS REQUIRED
C - INDICATES SHEET DETAIL IS DRAWN

no.	revision	date	by	approved
2	REVISED	28/10/2020	MH	RB
1	ISSUED FOR CONSTRUCTION	16/11/2018	JS	RN
0	ISSUED FOR TENDER	18/06/20	JS	RN

Project - projet

MCTS GENERATOR BLDG
ST. LAWRENCE

Drawing - dessin

ELECTRICAL DETAILS

drawn - dessine	M.G.G.	designed - dessine par	K.W.
date - date	AUGUST 2020	checked - verifie	D.C.
scale - echelle	AS SHOWN	approved for tender - approuve pour l'offre	R.N.

PANEL: DP-A LOCATION: GENERATOR ROOM MOUNTING: SURFACE
PANEL MODEL: SEE NOTE 1 **SERVICE:** 120/240, 1Ph., 3W **BRANCH_BKR_I.C.:**10,000 A. RMS Sym.
DATE: **PANEL SIZE:** 200 Amp MAINS, **BREAKER TYPE:** SEE NOTE 2
NON-COMBINATION

LOAD DESCRIPTION	LOAD WATTS	WIRE SIZE	BKR. SIZE	CIRCUIT NO.	BKR. SIZE	WIRE SIZE	LOAD WATTS	LOAD DESCRIPTION
SPARE (LOSS OF POWER RELAY)		#12	15A 2P	1 2 3 4	100A 2P	#3	8830 8830	EP-B
SURGE PROTECTION DEVICE		#12	30A 2P	5 6 7 8	20A 2P	#12	1000 1000	GENERATOR ROOM HEATER
(GEN. LOSS RELAY)		#12	15A 2P	9 10 11 12	15A #12	1000 600		SPARE (COOLANT HEATER) SPARE (GEN. BATT CHARGER)
SPARE		#12	15A	13 14	15A #12			SPARE
SPARE		#12	15A	15 16	15A #12			SPARE
SPARE		#12	15A	17 18	15A #12			SPARE
SPARE		#12	15A	19 20	15A #12			SPARE
SPARE		#12	15A	21 22	15A #12			SPARE
SPARE		#12	15A	23 24	15A #12			SPARE

COMMENTS: + LOCK ON DEVICE CONNECTED TO BREAKER.

NOTES: 1. SIEMENS TUB B38, INSERT P1A30MC250AT, TRIM S38B.
2. BRANCH BREAKERS TYPE B.

PANEL DETAIL DP-A 1
N.T.S. E3 E3

PANEL: EP-B LOCATION: EQUIPMENT ROOM MOUNTING: SURFACE
PANEL MODEL: SEE NOTE 1 **SERVICE:** 120/240, 1Ph., 3W **BRANCH_BKR_I.C.:**10,000 A. RMS Sym.
DATE: **PANEL SIZE:** 125 Amp MAINS, **BREAKER TYPE:** SEE NOTE 2
NON-COMBINATION

LOAD DESCRIPTION	LOAD WATTS	WIRE SIZE	BKR. SIZE	CIRCUIT NO.	BKR. SIZE	WIRE SIZE	LOAD WATTS	LOAD DESCRIPTION
SPARE		#12	15A	1 2	20A 2P	#12	1800 1800	A/C UNIT #1
SPARE (HEATER EQUIPMENT ROOM)	1000 1000	#12	15A 2P	5 6 7 8	15A #12	10 180		EMERG LTS + REC - GENERATOR ROOM
LIGHTING - INTERIOR	420	#12	15A	9 10	15A #12	180		REC - EXTERIOR
LIGHTING - EXTERIOR	20	#12	15A	11 12	15A #12	10		SMOKE/CO ALARM & GAS DET.
REC - BATTERY CHARGER	100	#12	15A	13 14	15A #12	180		REC - EQUIPMENT ROOM
SPARE (EQUIP. RM VENT)	100	#12	15A	15 16	15A #12	180		REC - EQUIPMENT ROOM
SPARE (EXHAUST FAN)	864	#12	15A	17 18	15A #12	100		TOWER LIGHTING
SPARE (VENT CONTROL)	50	#12	15A	19 20	15A #12	50		SPARE
SPARE (VENT CONTROL)	50	#12	15A	21 22	15A #12	180		REC - TELEPHONE EQUIP.
SPARE (REC - RACK 1)	900	#12	15A	23 24	15A #12	750		SPARE (REC - RACK 2)
SPARE (REC - RACK 3)	750	#12	15A	25 26	15A #12	750		SPARE (REC - RACK 4)
SPARE (REC-RACK5(FUTURE))	750	#12	15A	27 28	15A #12	750		SPARE (REC-RACK6(FUTURE))
SPARE	120	#12	15A	29 30	15A #12			SPARE
SPARE	120	#12	15A	31 32	15A #12			SPARE
SPARE		#12	15A	33 34	15A #12			SPARE
SPARE		#12	15A	35 36	15A #12			SPARE
SPARE		#12	15A	37 38	15A #12			SPARE
SPARE (PANEL UPS-C)	2600 2600	#8	60A 2P	39 40 41 42	100A 2P	#12		SPD

COMMENTS: + LOCK ON DEVICE CONNECTED TO BREAKER.

NOTES: 1. SIEMENS TUB B44, INSERT P1A42MC250AT, TRIM S44B.
2. BREAKERS TYPE B.

PANEL DETAIL EP-B 2
N.T.S. E3 E3

A A - INDICATES DETAIL NO.
B B - INDICATED SHEET DETAIL IS REQUIRED
C C - INDICATES SHEET DETAIL IS DRAWN

no.	revision	date	by	approved
2	REVISED	28/10/2020	MH	RB
1	ISSUED FOR CONSTRUCTION	16/11/2018	JS	RN
0	ISSUED FOR TENDER	18/06/20	JS	RN

Project - projet
MCTS GENERATOR BLDG
ST. LAWRENCE

Drawing - dessin
ELECTRICAL DETAILS AND
PANEL SCHEDULES

drawn - dessine	M.G.G.	designed - dessine par	K.W.
date - date	AUGUST 2020	checked - verifie	D.C.
scale - echelle	AS SHOWN	approved for tender - approuve pour l'offre	R.N.

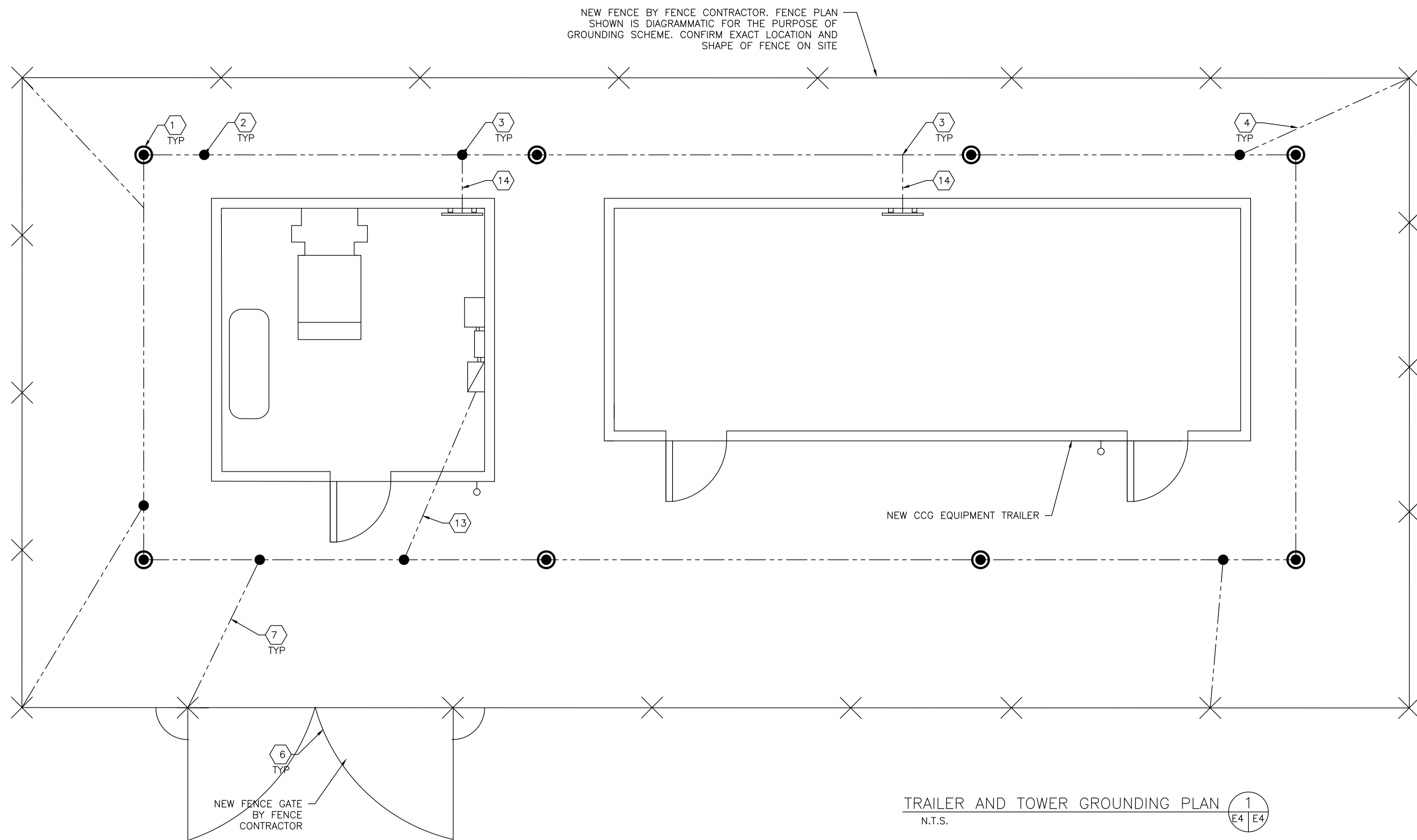

- 1 19mmØ x 3m LONG COPPER CLAD STEEL GROUND ROD. 6 REQUIRED.
- 2 NEW TRAILER GROUND GRID. # 2/0 BARE STRANDED COPPER CONDUCTOR BURIED AT 700mm BELOW FINISHED GRADE.
- 3 EXOTHERMIC CONNECTION BELOW GRADE.
- 4 BOND FENCE TO GROUNDING SYSTEM AT 10m INTERVALS USING #2/0 BARE STRANDED COPPER CONDUCTOR.
- 5 BOND EXISTING TOWER GROUND RING TO NEW FENCE USING #2/0 BARE STRANDED COPPER CONDUCTOR.
- 6 PROVIDE FLEXIBLE BONDING STRAP BETWEEN STATIONARY GATE POST AND GATE FRAME.
- 7 BOND EACH STATIONARY GATE POST TO TRAILER GROUND GRID.
- 8 BOND NEW TRAILER GROUND GRID TO EXISTING TOWER GRID RING USING #2/0 BARE STRANDED COPPER CONDUCTOR AT 2 LOCATIONS MINIMUM 2m APART.
- 9 BOND EACH WAVE GUIDE POST TO TRAILER GROUND GRID USING #2 INSULATED COPPER CONDUCTOR.
- 10 BOND EXTERIOR GROUND BAR OF THE TRAILER TO TRAILER GROUND GRID USING #2/0 INSULATED COPPER CONDUCTOR.
- 11 MAINTAIN A 200mm GAP BETWEEN THE WAVEGUIDE BRIDGE AND THE TRAILER AND BOND WAVEGUIDE BRIDGE TO EXTERIOR GROUND BAR USING #2 INSULATED COPPER CONDUCTOR.
- 12 BOND INTERIOR GROUND BAR OF THE TRAILER TO TRAILER GROUND GRID USING #2/0 INSULATED COPPER WIRE.
- 13 BOND SERVICE ENTRANCE NEUTRAL TO TRAILER GROUND GRID USING #6 INSULATED COPPER CONDUCTOR.
- 14 BOND GENERATOR COMPARTMENT GROUND BAR TO TRAILER GROUND GRID USING #2/0 INSULATED STRANDED COPPER CONDUCTOR.

 A - INDICATES DETAIL NO.
 B - INDICATED SHEET DETAIL IS REQUIRED
 C - INDICATES SHEET DETAIL IS DRAWN

no.	revision	date	by	approved
2	REVISED	28/10/2020	MH	RB
1	ISSUED FOR CONSTRUCTION	16/11/2018	JS	RN
0	ISSUED FOR TENDER	18/06/20	JS	RN

Project - projet

**MCTS GENERATOR BLDG
ST. LAWRENCE**

Drawing - dessin

GROUNDING PLAN

drawn - dessine	J.S.	designed - dessine par	K.W.
date - date	AUGUST 2020	checked - verifie	D.C.
scale - echelle	AS SHOWN	approved for tender - approuve pour l'offre	R.N.
project no. - projet no.	drawing no. - no du dessin	sheet - feuille	
	01L1402B02913-E04	13 OF 16	

GENERAL NOTES

1. ALL WORKMANSHIP, EXCEPT WHERE NOTED OTHERWISE SHALL BE IN ACCORDANCE WITH THE REQUIREMENTS OF THE NATIONAL BUILDING CODE OF CANADA (LATEST EDITION).
2. VERIFY ALL DIMENSIONS AND REPORT DISCREPANCIES BEFORE PROCEEDING WITH THE WORK. DO NOT SCALE THESE DRAWINGS.
3. FOR DIMENSIONS NOT GIVEN ON STRUCTURAL DRAWINGS SEE ARCHITECTURAL, MECHANICAL AND ELECTRICAL DRAWINGS.
4. FOR SIZE AND LOCATION OF MECHANICAL AND ELECTRICAL EQUIPMENT AND OPENINGS SEE MECHANICAL AND ELECTRICAL DRAWINGS. VERIFY ALL DIMENSIONS WITH THE MECHANICAL AND ELECTRICAL CONTRACTORS.
5. MAKE ADEQUATE PROVISIONS FOR CONSTRUCTION STRESSES, WEATHER PROTECTION AND FOR SUFFICIENT TEMPORARY BRACING AND SHORING TO KEEP THE STRUCTURE PLUMB AND LEVEL DURING ALL PHASES OF WORK. CONTRACTOR TO SUBMIT RESHORING DIAGRAMS FOR REVIEW STAMPED BY PROFESSIONAL ENGINEER AND LICENSED TO PRACTICE IN THE PROVINCE OF NEWFOUNDLAND & LABRADOR.
6. IT IS THE RESPONSIBILITY OF THE CONTRACTOR TO SAFEGUARD ALL EXISTING STRUCTURES AFFECTED BY THIS CONSTRUCTION.
7. ALL REQUIREMENTS FOR MECHANICAL AND ELECTRICAL EQUIPMENT AND ANY OTHER TRADES OR SERVICES AFFECTING THE STRUCTURE SHALL BE ESTABLISHED BY THE GENERAL CONTRACTOR IN CONSULTATION WITH CORRESPONDING MANUFACTURERS OR SUPPLIERS AND THE ARCHITECT AND THE ENGINEER.
8. DESIGN LOADS AS SHOWN ON DRAWINGS.
9. ALL LOADS AND FORCES SHOWN ON DRAWINGS ARE UNFACTORED U.N.O. IF LOADING TYPE IS NOT INDICATED, CONSIDER IT TO BE A LIVE LOAD. ALL LOADINGS ARE IN SYSTEM INTERNATIONAL UNITS U.N.O.

STRUCTURAL TIMBER NOTES

1. ALL TIMBER MEMBERS (TRUSSES, JOISTS, GLUE LAMINATED, PLYWOOD, ETC.) TO BE DESIGNED IN ACCORDANCE WITH CSA 086 LATEST EDITION.
2. FABRICATOR SHALL SUBMIT SHOP DRAWINGS STAMPED BY A PROFESSIONAL ENGINEER REGISTERED IN THE PROVINCE OF NEWFOUNDLAND & LABRADOR PRIOR TO COMMENCEMENT OF FABRICATION.
3. PROVIDE TRUSS PLATES WHERE BEARING WIDTH OF WOOD PLATES IS LESS THAN DESIGN WIDTH.
4. PROVIDE METAL TRUSS CONNECTORS FOR CONNECTION OR ROOF TRUSSES TO WOOD PLATES. GROSS UPLIFT LOAD FOR ROOF TRUSSES ARE 1.5 KPa U.N.O.
5. PLYWOOD NAILING SCHEDULE:
ROOF AND CEILING SHEATHING
 64mm NAILS @ 100 O.C. AT PLYWOOD EDGES
 64mm NAILS @ 300 O.C. AT INTERIOR OF SHEET
WALL SHEATHING
 64mm NAILS @ 150 O.C. AT PLYWOOD EDGES
 64mm NAILS @ 300 O.C. AT INTERIOR OF SHEET
6. WOOD JOISTS, BEAMS AND STUDS TO BE SPRUCE-PINE-FIR GRADE No.1/No.2
7. ROOF AND CEILING SHEATHING TO BE FULLY BLOCKED ATTACHED TO FRAMING IN FOLLOWING CONFIGURATION.

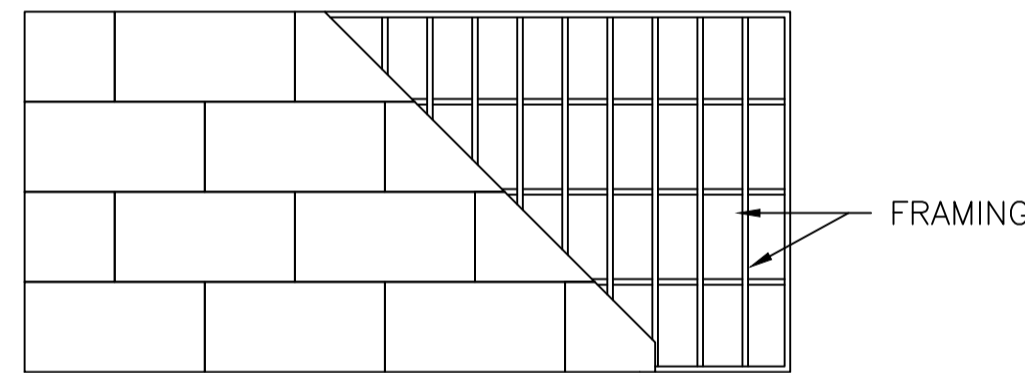

8. WALL SHEATHING TO BE FULLY BLOCKED AND ATTACHED TO FRAMING IN FOLLOWING CONFIGURATION.

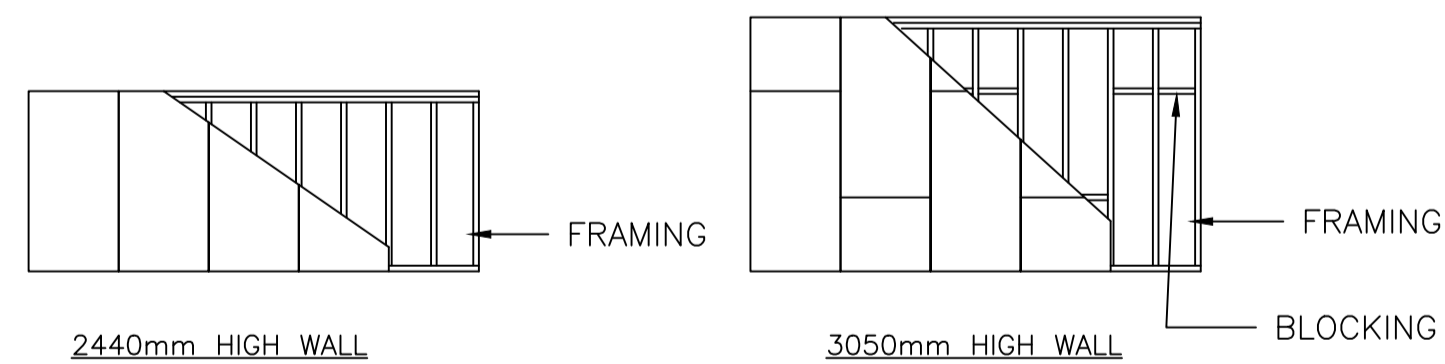

9. SHEAR WALL HOLD-DOWN ANCHORS REQUIRED AT BOTH ENDS FOR EACH SEGMENT OF UNINTERRUPTED WALL.
10. ALL SURFACES OF PRESSURE TREATED LUMBER THAT ARE EXPOSED THROUGH FIELD CUTTING, TRIMMING OR BORING MUST BE RE-TREATED WITH A LIBERAL APPLICATION OF PRESERVATIVE BEFORE INSTALLATION.

INSULATION NOTES

1. ALL BATT INSULATION TO CAN/ULC S702.
2. INSULATION SHALL BE INSTALLED AS PER MANUFACTURER'S RECOMMENDATIONS.
3. INSTALL INSULATION WITH FACTORY APPLIED VAPOUR BARRIER FACING WARM SIDE OF BUILDING SPACES. LAP ENDS AND SIDE FLANGES OF MEMBRANE OVER FRAMING MEMBERS. RETAIN IN POSITION WITH STAPLES. INSTALLED AS RECOMMENDED BY MANUFACTURER. TAPE SEAL BUTT ENDS AND LAPPED SIDE FLANGES. DO NOT CUT OR TEAR VAPOUR BARRIER.

PAINTING NOTES

1. ALL WORK TO CONFORM TO LATEST MPI REQUIREMENTS FOR INTERIOR PAINTING WORK INCLUDING PREPARATION AND PRIMING.
2. STANDARD OF ACCEPTANCE AS FOLLOWS:
 WALLS: NO DEFECTS VISIBLE FROM A DISTANCE OF 1000mm AT 90 DEGREES TO SURFACE
 CEILINGS:NO DEFECTS VISIBLE FROM FLOOR AT 45 DEGREES TO SURFACE WHEN VIEWED USING FINAL LIGHTING SOURCE.
 FINAL COAT TO EXHIBIT UNIFORMITY OF COLOUR AND UNIFORMITY OF SHEEN ACROSS FULL SURFACE AREA.
3. SUBMIT PRODUCT DATA AND MANUFACTURER'S INSTALLATION/SPPICATION FOR EACH PAINT AND COATING PRODUCT TO BE USED.
4. PAINT MATERIALS FOR PAINT SYSTEMS SHALL BE PRODUCTS OF A SINGLE MANUFACTURER.
5. ONLY QUALIFIED PRODUCTS WITH E2 "ENVIRONMENTALLY FRIENDLY" RATING ARE ACCEPTABLE FOR USE ON THIS PROJECT.
6. UPON COMPLETION, SUBMIT RECORDS OF PRODUCTS USED. LIST PRODUCTS IN RELATION TO FINISH SYSTEM AND INCLUDE THE FOLLOWING:
 - 6.1. PRODUCT NAME, TYPE AND USE
 - 6.2. MANUFACTURER'S PRODUCT NUMBER
 - 6.3. COLOUR NUMBER
 - 6.4. MPI ENVIRONMENTALLY FRIENDLY CLASSIFICATION SYSTEM RATING
 - 6.5. MANUFACTURER'S MATERIAL SAFETY DATA SHEETS (MSDS)
7. SITE REQUIREMENTS
 - 8.1 HEATING, VENTILATION AND LIGHTING:
 - a) PERFORM NO PAINTING WORK UNLESS ADEQUATE AND CONTINUOUS VENTILATION AND SUFFICIENT HEATING FACILITIES ARE IN PLACE TO MAINTAIN AMBIENT AIR AND SUBSTRATE TEMPERATURES ABOVE 10 OC FOR 24 HOURS BEFORE, DURING AND AFTER PAINT APPLICATION UNTIL PAINT HAS CURED SUFFICIENTLY.
 - b) WHERE REQUIRED, PROVIDE CONTINUOUS VENTILATION FOR SEVEN DAYS AFTER COMPLETION OF APPLICATION OF PAINT.
 - c) PERFORM NO PAINTING WORK UNLESS A MINIMUM LIGHTING LEVEL OF 323 LUX IS PROVIDED ON SURFACES TO BE PAINTED. ADEQUATE LIGHTING FACILITIES SHALL BE PROVIDED BY GENERAL CONTRACTOR.
 - 8.2 TEMPERATURE, HUMIDITY AND SUBSTRATE MOISTURE CONTENT LEVELS:
 - a) UNLESS SPECIFICALLY PRE-APPROVED BY THE SPECIFYING BODY, PAINT INSPECTION AGENCY AND THE APPLIED PRODUCT MANUFACTURER, PERFORM NO PAINTING WORK WHEN:
 - AMBIENT AIR AND SUBSTRATE TEMPERATURES ARE BELOW 10 OC.
 - SUBSTRATE TEMPERATURE IS OVER 32 OC UNLESS PAINT IS SPECIFICALLY FORMULATED FOR APPLICATION AT HIGH TEMPERATURES.
 - SUBSTRATE AND AMBIENT AIR TEMPERATURES ARE EXPECTED TO FALL OUTSIDE MPI OR PAINT MANUFACTURERS PRESCRIBED LIMITS.
 - THE RELATIVE HUMIDITY IS ABOVE 85% OR WHEN THE DEW POINT IS LESS THAN 3 OC VARIANCE BETWEEN THE AIR/SURFACE TEMPERATURE.
 - RAIN OR SNOW ARE FORECAST TO OCCUR BEFORE PAINT HAS THOROUGHLY CURED OR WHEN IT IS FOGGY, MISTY, RAINING OR SNOWING AT SITE.
 - b) PERFORM NO PAINTING WORK WHEN THE MAXIMUM MOISTURE CONTENT OF THE SUBSTRATE EXCEEDS:
 - 15% FOR WOOD.
 - c) CONDUCT MOISTURE TESTS USING A PROPERLY CALIBRATED ELECTRONIC MOISTURE METER, EXCEPT TEST CONCRETE FLOORS FOR MOISTURE USING A SIMPLE "COVER PATCH TEST".
 - d) TEST CONCRETE, MASONRY AND PLASTER SURFACES FOR ALKALINITY AS REQUIRED.
 - 8.3 SURFACE AND ENVIRONMENTAL CONDITIONS:
 - a) APPLY PAINT FINISH ONLY IN AREAS WHERE DUST IS NO LONGER BEING GENERATED BY RELATED CONSTRUCTION OPERATIONS OR WHEN WIND OR VENTILATION CONDITIONS ARE SUCH THAT AIRBORNE PARTICLES WILL NOT AFFECT QUALITY OF FINISHED SURFACE.
 - b) APPLY PAINT ONLY TO ADEQUATELY PREPARED SURFACES AND TO SURFACES WITHIN MOISTURE LIMITS NOTED HEREIN.
 - c) APPLY PAINT ONLY WHEN PREVIOUS COAT OF PAINT IS DRY OR ADEQUATELY CURED.
 - 8.4 ADDITIONAL INTERIOR APPLICATION REQUIREMENTS:
 - a) APPLY PAINT FINISHES ONLY WHEN TEMPERATURE AT LOCATION OF INSTALLATION CAN BE SATISFACTORILY MAINTAINED WITHIN MANUFACTURER'S RECOMMENDATIONS.

 A - INDICATES DETAIL NO.
 B - INDICATED SHEET DETAIL IS REQUIRED
 C - INDICATES SHEET DETAIL IS DRAWN

2	REVISED	28/10/2020	MH	RB
1	ISSUED FOR CONSTRUCTION	17/06/19	JS	RN
0	ISSUED FOR TENDER	16/08/17	JS	RN
no. no	revision revision	date date	by par	approved approve

Project - projet

MCTS GENERATOR BLDG
ST. LAWRENCE

Drawing - dessin

ARCHITECTURAL & STRUCTURAL
NOTES

drawn - dessine	J.S.	designed - dessinée par	R.N.
date - date	MAY 2017	checked - vérifié	R.N.
scale - échelle	AS SHOWN	approved for tender - approuvé pour l'offre	R.N.
project no. - projet no.	drawing no. - no du dessin	sheet - feuille	
	01L1402B02914-N1	14 OF 16	

PART 1: GENERAL

1.13 COMMISSIONING

- .1 PROVIDE ALL NECESSARY LABOUR, MATERIALS, TOOLS, AND EQUIPMENT FOR IMPLEMENTING ALL REQUIRED COMMISSIONING ACTIVITIES INCLUDING: ALL CHECKING, TESTING, ADJUSTING, AND FINE TUNING OF SYSTEM SET POINTS AND TO PUT SYSTEMS INTO OPERATION.
- .2 COMPLETE A SYSTEMATIC VERIFICATION PROCEDURE TO ENSURE THAT:
 - .1 EQUIPMENT AND MATERIAL DELIVERED AND INSTALLED ARE AS PER APPROVED SHOP DRAWINGS, IN ACCORDANCE WITH ALL APPLICABLE CODES, NORMAL GOOD PRACTICE, MANUFACTURER'S INSTALLATION GUIDELINES, AND REQUIREMENTS OF THESE SPECIFICATIONS,
 - .2 PIPING AND DUCTWORK IS PRESSURE TESTED AS REQUIRED,
 - .3 EQUIPMENT IS SAFE TO BE STARTED.
- .3 COMPLETE A SYSTEMATIC VERIFICATION PROCEDURE TO ENSURE THAT EQUIPMENT AND SYSTEMS OPERATE SAFELY, EFFICIENTLY, AND IN GENERAL CONFORMITY WITH THE DESIGN INTENT INCLUDING:
 - .1 VERIFYING OPERATING CONDITIONS,
 - .2 VERIFYING PROPER OPERATION OF ALL SAFETY DEVICES,
 - .3 VERIFYING HYDRONIC SYSTEM FLUIDS ARE CLEAN AND TREATED AS PER SPECIFICATIONS,
 - .4 VERIFYING CONTROL SYSTEM OPERATION,
 - .5 VERIFYING SATISFACTORY EQUIPMENT OPERATING POINTS (PUMPS AND FANS) AND MOTOR LOADING,
 - .6 VERIFYING LINKAGE BETWEEN INTERACTING SYSTEMS,

1.4 CARE, OPERATION AND START-UP

- .1 MANUFACTURERS OR THEIR AGENTS TO UNDERTAKE EQUIPMENT START-UP WHERE REQUIRED BY THE SPECIFICATIONS OR WHERE REQUIRED BY THE EQUIPMENT MANUFACTURER AS A CONDITION OF WARRANTY. WHERE MANUFACTURER IS NOT REQUIRED TO DO START-UP, CARRY OUT IN ACCORDANCE WITH MANUFACTURER'S WRITTEN INSTRUCTIONS.
- .2 INSTRUCT OPERATING PERSONNEL IN THE OPERATION, CARE, MAINTENANCE OF EQUIPMENT.

1.15 TESTING

- .1 TEST ALL PIPING TO 150% OF OPERATING PRESSURE FOR 8 HOURS, OR AS REQUIRED BY CODES.

1.17 IDENTIFICATION

- .1 IDENTIFY ALL EQUIPMENT WITH ENGRAVED LAMACOID PLATES.
- .2 IDENTIFY ALL VALVES WITH NUMBERED BRASS TAGS. RECORD VALVE NUMBERS, SERVICE AND NORMAL POSITION ON VALVES SCHEDULE. INCLUDE VALVE SCHEDULE IN MAINTENANCE MANUALS.

PART 2 INSULATION

2.1 GENERAL

- .1 INSULATION TO NFPA-90-A MAXIMUM FLAME-SPREAD AND SMOKE-DEVELOPED RATINGS OF 25 AND 50 RESPECTIVELY. INSTALL ALL INSULATION AS PER MANUFACTURER'S RECOMMENDATIONS.
- .2 THERMAL CONDUCTIVITY ("K" FACTOR) NOT TO EXCEED SPECIFIED VALUES AT 24 DEGREES C MEAN TEMPERATURE WHEN TESTED IN ACCORDANCE WITH ASTM C 335.

2.2 PRODUCT

- .1 TIAC CODE A-2: RIGID MOULDED CALCIUM SILICATE IN SECTIONS AND BLOCKS, AND WITH SPECIAL SHAPES TO SUIT PROJECT REQUIREMENTS.
 - .1 INSULATION: ASTM C533.
 - .2 MAXIMUM "K" FACTOR: ASTM C533.
 - .3 DESIGN TO PERMIT PERIODIC REMOVAL AND RE-INSTALLATION.
- .2 SECUREMENT
 - .1 TAPE: SELF-ADHESIVE, ALUMINUM, PLAIN, 50 MM WIDE MINIMUM.
 - .2 TIE WIRE: 1.5 MM DIAMETER STAINLESS STEEL.
 - .3 BANDS: STAINLESS STEEL, 19 MM WIDE, 0.5 MM THICK.
 - .4 FACING: 25 MM GALVANIZED STEEL HEXAGONAL WIRE MESH ON ONE FACE OF INSULATION.
 - .5 FASTENERS: 4 MM DIAMETER PINS WITH 35 MM DIAMETER OR SQUARE CLIPS.
- .3 JACKETS
 - .1 ALUMINUM: TO 0.5 MM THICK WITH LONGITUDINAL SLIP JOINTS AND 50 MM END LAPS, 0.4 MM THICK DIE SHAPED FITTING COVERS WITH FACTORY ATTACHED PROTECTIVE LINER ON INTERIOR SURFACE.

2.3 EXECUTION

- .1 INSTALL IN ACCORDANCE WITH TIAC NATIONAL STANDARDS AND AS PER MANUFACTURER'S RECOMMENDATIONS.
- .2 RE-COVER ALL GENERATOR EXHAUST PIPING AND MUFFLER WITH INSULATED JACKET.
- .3 PROVIDE INSULATION SHIELDS AT ALL PIPE HANGERS.
- .4 PIPE AND DUCT INSULATION SCHEDULE.

SERVICE	TIAC CODE	THICKNESS
ENGINE EXHAUST	A-2	50 MM

PART 3: FIRE PROTECTION

3.1 GENERAL

- .1 REFERENCES
 - .1 PROVINCIAL AND LOCAL BUILDING CODES, AND FIRE REGULATIONS AS APPROVED BY THE AUTHORITY HAVING JURISDICTION.
 - .2 NATIONAL FIRE PROTECTION ASSOCIATION STANDARDS:
 - .1 NFPA 10 – PORTABLE FIRE EXTINGUISHERS

PART 4: PIPING, VALVES AND FITTINGS

4.1 GENERAL

- .1 PROVIDE COMPLETE, FULLY OPERATIONAL PIPING SYSTEMS COMPLETE WITH ALL ISOLATION, CHECK, PRESSURE REDUCING AND BACKFLOW PREVENTION VALVES AS INDICATED AND FURTHER AS REQUIRED FOR PROPER SYSTEM OPERATION AND TO SATISFY LOCAL CODES.

4.2 PRODUCTS

- .1 PIPE AND FITTINGS
 - .1 STEEL: ASTM A53 GRADE B, SEAMLESS UP TO NPS 2, ERW FOR LARGER
 - .2 SERVICE:

SERVICE	PIPE SIZE	MATERIAL	FITTINGS
FUEL OIL	ALL	SCHEDULE 40 STAINLESS STEEL	SCREWED
GENERATOR EXHAUST	NPS 3 AND OVER	SCHEDULE 40 STEEL	WELDED

.2 VALVES

- .1 GATE VALVES:
 - .1 NPS2 AND UNDER: BRONZE BODY, RISING STEM: TO MSS-SP-80, CLASS 125, 860 KPA SOLID WEDGE DISC, HANDWHEEL OPERATOR
- .2 GLOBE VALVES:
 - .1 NPS 2 AND UNDER: TO MSS-SP-80, CLASS 125, 860 KPA, BRONZE BODY, SCREWED OVER BONNET, RENEWABLE BRONZE DISC (COMPOSITION DISC SUITABLE FOR OIL SERVICE)
- .3 CHECK VALVES:
 - .1 NPS 2 AND UNDER: SWING TYPE, TO MSS-SP-80, CLASS 125, 860 KPA, BRONZE BODY, BRONZE SWING DISC (RENEWABLE COMPOSITION DISC SUITABLE FOR OIL SERVICE), SCREW IN CAP, REGRINDABLE SEAT
- .4 BALL VALVES:
 - .1 NPS 2 AND UNDER: BRONZE BODY, TFE SEAL, HARD CHROME BALL, 4 MPA, WOG, HANDLE OPERATOR

4.3 EXECUTION

- .1 NPS2 AND UNDER: SCREWED FITTINGS WITH PTFE TAPE OR LEAD-FREE PIPE DOPE.
- .2 CONNECT TO EQUIPMENT WITH UNIONS OR FLANGES. INSTALL PIPING OR MINIMIZE PIPE DISMANTLING FOR EQUIPMENT REMOVAL.
- .3 EACH PIECE OF EQUIPMENT TO BE ISOLATED BY GATE, OR BALL VALVES.
- .4 INSTALL VALVES WITH STEMS IN UPRIGHT OR HORIZONTAL POSITION. DO NOT INSTALL STEMS IN INVERTED POSITION.
- .5 PROVIDE SPRING HANGERS AND FLEXIBLE CONNECTIONS WHEN MAKING CONNECTION TO VIBRATION ISOLATED EQUIPMENT. OIL LINES TO DIESEL GENERATORS SHALL HAVE A MINIMUM 12" (300MM) LONG FLEXIBLE STAINLESS STEEL BRAID REINFORCED CONNECTIONS.
- .6 PROVIDE ALL PIPING TO FUEL TANK AND BETWEEN TANK AND ENGINE INCLUDE FILL, VENTS, SUPPLY AND RETURN, AND ALL CONNECTIONS TO FUEL TANK, AND ENGINE. GRADE PIPING AT 1% BACK TO TANK.
- .7 SUPPORT ALL PIPING FROM STRUCTURAL MEMBERS AS APPROVED BY ENGINEER. WHEN STRUCTURAL MEMBERS ARE NOT SUITABLE LOCATION, PROVIDE SUPPLEMENTARY MEMBERS SUCH AS STEEL CHANNELS OR ANGLES (OBTAIN APPROVAL PRIOR TO FABRICATION). HANGER SYSTEMS TO BE STEEL ROD AND CLEVIS, ANGLE IRON OR CHANNEL. STRAP HANGER NOT TO BE USED.
- .8 PIPE SUPPORTS SHALL MEET REQUIREMENTS OF ANSI B31.1. USE ROD DIAMETERS AND SUPPORT SPACING AS SHOWN BELOW WITH THE FOLLOWING EXCEPTIONS:
 - .1 SUPPORT APPROVED MECHANICAL JOINT PIPING WITH AT LEAST TWO HANGERS BETWEEN EACH JOINT OR FITTING.
 - .2 SUPPORT PLASTIC PIPE IN ACCORDANCE WITH MANUFACTURER'S RECOMMENDATIONS.

PIPE SIZE NPS	ROD DIAMETER	MAXIMUM SPACING STEEL	COPPER
½	10 MM	1.8 M	1.5 M
¾ TO 1 ¼	10 MM	2.1M	1.8 M
1 ½	10 MM	2.7 M	2.4 M
2	10 MM	3.0 M	2.7 M
2 ½ TO 3	10 MM	3.6 M	3.0 M
4	10 MM	3.6 M	3.6 M
6	10 MM	4.8 M	

PART 5: HEATING, VENTILATION AND AIR CONDITIONING

5.1 GENERAL

- .1 PROVIDE ALL LABOUR, MATERIALS AND EQUIPMENT REQUIRED FOR COMPLETE HEATING, VENTILATION AND AIR CONDITIONING SYSTEMS GENERALLY INCLUDE THE FOLLOWING:

5.2 PRODUCTS

- .1 WALL MOUNTED EXHAUSTER:
 - .1 FULLY ASSEMBLED, STURDILY CONSTRUCTED DIRECT DRIVE, WALL MOUNTED HORIZONTAL EXHAUST FAN, DURABLE POWER COATED FINISH, HEAVY DUTY OSHA MOTOR/GUARD, ENCLOSED AIR OVER MOTOR WITH OVERLOAD PROTECTION, DISCONNECT SWITCH. FAN SPECIFICATIONS: "LFI" MODEL P24-1V, 124 BLADE DIAMETER, DIMENSION 29.25"x29.25", AIR FLOW 3,520CFM @ 0.25" STATIC PRESSURE. ELECTRICAL POWER SUPPLY: 115/1/60, 1/3HP.
 - .2 STANDARD OF ACCEPTANCE: LFI OR EQUAL.
- .2 INTERIOR DUCTWORK SHALL BE FABRICATED FROM GALVANIZED STEEL TO ASTM A525 G90 DESIGNATION. METAL GAUGE SHALL BE IN ACCORDANCE WITH SMACNA STANDARDS.
- .3 EXTERIOR HOODS DUCTWORK SHALL BE FABRICATED FROM ALUMINUM TYPE 3003-H-14 SHEET MATERIAL. METAL GAUGE SHALL BE IN ACCORDANCE WITH SMACNA STANDARDS.
- .4 INTAKE/RELIEF DAMPERS: ALUMINUM FRAME WITH POLYURETHANE POCKETS, ALUMINUM BLADES WITH POLYURETHANE INTERNALLY INSULATION (R-2.25 MINIMUM), SILICONE BLADE AND SIDE SEALS, AMCA CERTIFIED, SALT WATER RESISTANCE INCLUDING STAINLESS STEEL HARDWARE.
 - .1 STANDARD OF ACCEPTANCE: TAMCO 9000 SW.

5.3 EXECUTION

- .1 INSTALL ALL EQUIPMENT IN ACCORDANCE WITH MANUFACTURER'S RECOMMENDATION.
- .2 ALL EQUIPMENT TO BE VIBRATION ISOLATED. USE RUBBER ISOLATORS FOR EQUIPMENT LESS THAN 30 KG SPRING ISOLATORS FOR LARGER EQUIPMENT.
- .3 PROVIDE TYPE "L" COPPER WITH COPPER FITTINGS CONDENSATE PIPING FROM WALL MOUNTED INDOOR UNIT.
- .4 MANUFACTURE AND INSTALL ALL DUCTWORK IN ACCORDANCE WITH THE RECOMMENDATION OF SMACNA.
- .5 ALL DUCTWORK CONNECTION TO ISOLATED EQUIPMENT TO BE MADE USING 100 MM FLEXIBLE CONNECTORS.
- .6 SEAL ALL JOINTS IN DUCTWORK.
- .7 MAKE TRANSITIONS, OFFSETS OR EASEMENTS IN DUCT SYSTEMS WHERE REQUIRED TO AVOID CONFLICT WITH STRUCTURE OR OTHER TRADES. COORDINATE LOCATION OF DUCTWORK WITH OTHER TRADES TO MINIMIZE ALTERATIONS.

PART 6: DIESEL GENERATOR INSTALLATION

6.1 GENERAL

- .1 DIESEL ELECTRIC GENERATOR IS SPECIFIED UNDER THE ELECTRICAL SECTION, INCLUDING MUFFLER AND EXHAUST FLEXIBLE CONNECTIONS.

6.2 PRODUCTS

- .1 MUFFLER AND EXHAUST FLEXIBLE CONNECTIONS PROVIDED WITH GENERATOR.
- .2 ABOVE GROUND OIL STORAGE TANK SHALL BE FIBERGLASS REINFORCED PLASTIC, VILCO OR OTHER APPROVED MANUFACTURER. SUITABLE FOR ABOVE GROUND INSTALLATION, UNDERWRITER'S APPROVED AND LABELLED.
- .3 TANK SHALL BE 200 IMPERIAL GALLONS (909 LITERS) COMPLETE WITH TOP INLET, VENTS, LEVEL GAUGE CONNECTION, DRAIN VALVE, AND OUTLET AND RETURN CONNECTIONS.
- .4 PROVIDE TANK WITH GAUGE GLASS FOR FULL HEIGHT OF TANK COMPLETE WITH GAUGE COCKS.
- .5 FUEL LEVEL GAUGE C/W ALARM WIRING. OWNER TO SUPPLY PRODUCT INFORMATION.
- .6 AFTER ALL TESTS AND PLANT ACCEPTANCE, TANK SHALL BE COMPLETELY FILLED WITH OIL, GRADE AS APPLICABLE. PROVIDE CERTIFICATE THAT THE TANK HAS BEEN FILLED. INCLUDE FOR COST OF OIL FOR TESTING AND TO FILL SYSTEM AFTER TESTS.
- .7 PROVIDE WIRING SCHEMATIC FOR REVIEW.

6.3 EXECUTION

- .1 INSTALL EXHAUST PIPE, MUFFLER, FLEXIBLE PIPE CONNECTION AND FLAPPER VALVE OR RAIN CAP IN EXHAUST PIPE. PROVIDE A COMPLETE INSTALLATION FROM THE GENERATOR ENGINE FLANGE.
- .2 INSTALL A FLEXIBLE CONNECTION ON THE GENERATOR RADIATOR AND PROVIDE ALL DUCTWORK, MOTORIZED DAMPERS, AND WEATHER-PROOF HOODS FOR EXHAUST, OUTSIDE AIR INTAKE AND RECIRCULATING AIR.
- .4 PROVIDE A CONDENSATE DRAIN PIPE FROM THE MUFFLER.

PART 7: CONTROLS SYSTEM

7.1 GENERAL

- .1 PROVIDE ALL THERMOSTATS, SENSORS, ACTUATORS, CONTROLLER, OPERATORS AND ACCESSORIES AS REQUIRED FOR FULL OPERATIONAL SEQUENCE AS DESCRIBED HEREIN.

7.2 PRODUCTS

- .1 WIRING: ALL WIRING TO BE IN ACCORDANCE WITH ELECTRICAL SPECIFICATION.

7.3 EXECUTION

- .1 GENERAL
 - .1 INSTALL SYSTEMS AND RELATED CONTROLS USING FACTORY TRAINED JOURNEYMAN CERTIFIED BY THE PROVINCE OF NEWFOUNDLAND LABRADOR.

7.4 SEQUENCE OF OPERATION

- .1 MOTORIZED DAMPERS FOR CONTROL OPERATION (GENERATOR ROOM)
 - .1 REFER TO DRAWING M1.
- .2 WALL MOUNTED EXHAUST FAN (ELECTRICAL/EQUIPMENT ROOM)
 - .1 IN FAILURE OF HEAT PUMP UNITS AND SPACE THERMOSTAT CALLS FOR COOLING, MOTORIZED DAMPER ASSOACITED TO EXHAUST FAN 100% OPEN, EXHAUST FAN "ON", INTAKE AIR DAMPER 100% OPEN. BOTH DAMPERS ARE CLOSED AND EXHAUST FAN "OFF" WHEN THERMOSTAT REACH TEMPERATURE SET-POINT.
 - .2 EXHAUST FAN "OFF AND BOTH DAMPERS IN CLOSE POSITION WHEN HEAT PUMP UNITS ARE IN OPERATION.



Fisheries and Oceans
Coast Guard

Pêches et Océans
Garde côtière



A - INDICATES DETAIL NO.
B - INDICATED SHEET DETAIL IS REQUIRED
C - INDICATES SHEET DETAIL IS DRAWN

no.	revision	date	by	approved
2	REVISED	28/10/2020	MH	RB
1	ISSUED FOR CONSTRUCTION	17/06/19	JS	RN
0	ISSUED FOR TENDER	16/08/17	JS	RN

Project – projet
MCTS GENERATOR BLDG
ST. LAWRENCE

Drawing – dessin
MECHANICAL NOTES

drawn – dessine	J.S.	designed – dessine par	T.T.
date – date	MAY 2017	checked – vérifie	R.N.
scale – echelle	AS SHOWN	approved for tender – approuve pour l'offre	R.N.
project no. – projet no.	drawing no. – no du dessin	sheet – feuille	
	01L1402B02915-N2	15 OF 16	

260000 GENERAL

- PERFORM DETAILED VERIFICATION OF WORK PRIOR TO ORDERING THE ELECTRICAL EQUIPMENT AND COMMENCING CONSTRUCTION. VERIFY EQUIPMENT DIMENSIONS WITH THE VENDOR AND ENSURE THE EQUIPMENT WILL FIT IN THE AVAILABLE SPACE. ISSUE A WRITTEN NOTICE TO THE ENGINEER OF ANY DISCREPANCIES.
- SUBMIT SHOP DRAWINGS, PRODUCT DATA AND SAMPLES IN ACCORDANCE WITH SPECIFICATIONS. INDICATE DETAILS OF CONSTRUCTION, DIMENSIONS, CAPACITIES, WEIGHTS AND ELECTRICAL PERFORMANCE CHARACTERISTICS OF EQUIPMENT OR MATERIAL. WHERE APPLICABLE INCLUDE WIRING AND SINGLE LINE DIAGRAMS. ADVERTISING OR SALES LITERATURE WILL NOT BE ACCEPTABLE AS SHOP DRAWINGS.
- PROVIDE ALL LABOR, MATERIAL, EQUIPMENT, INSURANCE AND SERVICES TO COMPLETE ELECTRICAL INSTALLATION IN THE TELECOM EQUIPMENT BUILDING IN ACCORDANCE WITH THE DESIGN AND SPECIFICATIONS AND PRESENT IT AS FULLY OPERATIONAL TO THE SATISFACTION OF THE OWNER.
- CARRY OUT WORK IN ACCORDANCE WITH ALL APPLICABLE CODES STANDARDS, ORDINANCES AND HEALTH & SAFETY RULES.
- COORDINATE THE WORK PERTAINING TO POWER, GROUNDING AND COMMUNICATIONS FOR EQUIPMENT WITH SUPPLIER PRIOR TO ROUGH-IN. FINAL TERMINATIONS TO BE AT THE DIRECTION OF THE EQUIPMENT SUPPLIER.
- PROVIDE ALL CUTTING AND PATCHING NECESSARY FOR THE INSTALLATION OF THE ELECTRICAL WORK. ANY DAMAGE DONE TO THE WORK ALREADY IN PLACE BY REASON OF THIS WORK SHALL BE REPAIRED AT THE CONTRACTOR'S EXPENSE BY A QUALIFIED TRADESPERSON EXPERIENCED IN SUCH WORK. PATCHING SHALL BE UNIFORM IN APPEARANCE AND SHALL MATCH THE SURROUNDING SURFACE. DO NOT CUT STRUCTURAL MEMBERS WITHOUT APPROVAL OF THE STRUCTURAL ENGINEER.
- FABRICATION AND INSTALLATION OF THE COMPLETE ELECTRICAL SYSTEM SHALL BE DONE IN A FIRST CLASS WORKMANSHIP BY QUALIFIED PERSONNEL EXPERIENCED IN SUCH WORK AND SHALL SCHEDULE THE WORK IN AN ORDERLY MANNER SO AS NOT TO IMPEDE PROGRESS OF THE PROJECT.
- AT THE COMPLETION OF THE ELECTRICAL INSTALLATION PROVIDE THREE SETS OF OPERATION AND MAINTENANCE MANUALS, BOUND IN 3-RING HARD COVER BINDERS, DULY LABELED, AND CONTAINING COMPLETE LIST OF REPLACEMENT PARTS, SHOP DRAWINGS AND CATALOG INFORMATION OF ALL MAJOR EQUIPMENT, SUCH AS, DISTRIBUTION BOARD, GENERATOR, ATS, LUMINARIES, PANEL BOARD, PANEL SCHEDULE, MOTOR STARTERS, SECURITY SYSTEM, CABLE RACKS, ETC.
- COMPLETE INSTALLATION SHALL BE GUARANTEED FOR A PERIOD OF ONE (1) YEAR AFTER THE DATE OF WRITTEN ACCEPTANCE OF THE EQUIPMENT BUILDING BY OWNER. ANY WORK, MATERIAL OR EQUIPMENT FOUND TO BE FAULTY DURING THAT PERIOD SHALL BE CORRECTED AT ONCE, UPON WRITTEN NOTIFICATION, AT THE EXPENSE OF THE CONTRACTOR.

260500 BASIC MATERIALS AND METHODS

- INSTALLATION, MATERIALS, EQUIPMENT AND WORKMANSHIP SHALL CONFORM TO THE APPLICABLE PROVISIONS OF THE LOCAL ELECTRICAL CODE AND THE TERMS, CONDITIONS AND REGULATIONS OF THE AUTHORITY HAVING LAWFUL JURISDICTION PERTAINING TO THE WORK REQUIRED. ALL MATERIAL, EQUIPMENT AND DEVICES SHALL CONFORM TO THE APPLICABLE CSA AND ULC STANDARDS.
- ALL MATERIALS AND EQUIPMENT SHALL BE NEW. MATERIALS AND EQUIPMENT SHALL BE THE STANDARD PRODUCTS OF MANUFACTURER'S CURRENT DESIGN. ANY FIRST-CLASS PRODUCT MADE BY A REPUTABLE MANUFACTURER MAY BE USED PROVIDING IT CONFORMS TO THE DESIGN REQUIREMENTS AND MEETS THE APPROVAL OF THE ENGINEER AND THE OWNER. APPROVALS SHALL BE OBTAINED PRIOR TO PURCHASE.
- ARRANGE CONDUIT, WIRING, EQUIPMENT, AND OTHER WORK GENERALLY AS SHOWN, PROVIDING PROPER CLEARANCES AND ACCESS. CAREFULLY EXAMINE ALL CONTRACT DRAWINGS AND FIT THE WORK IN EACH LOCATION WITHOUT SUBSTANTIAL ALTERATION. WHERE DEPARTURES ARE PROPOSED BECAUSE OF FIELD CONDITIONS OR OTHER CAUSES, PREPARE AND SUBMIT DETAILED DRAWINGS FOR ACCEPTANCE. THE RIGHT IS RESERVED TO MAKE REASONABLE CHANGES IN LOCATION OF EQUIPMENT, CONDUIT, AND WIRING UP TO THE TIME OF ROUGH-IN OR FABRICATION.
- THE CONTRACT DRAWINGS ARE GENERALLY DIAGRAMMATIC AND ALL OFFSETS, BENDS, FITTINGS AND ACCESSORIES ARE NOT NECESSARILY SHOWN. PROVIDE ALL SUCH ITEMS AS MAY BE REQUIRED TO FIT THE WORK TO THE CONDITIONS.
- MOUNTING HEIGHTS OF ALL WIRING DEVICES SHALL BE VERIFIED WITH THE OWNER PRIOR TO INSTALLATION.

260510 IDENTIFICATION

- ALL EQUIPMENT SHALL BE IDENTIFIED USING NAMEPLATES AND LABELS.
- NAMEPLATES SHALL BE 1/8" (3mm) THICK PLASTIC ENGRAVING SHEET, WHITE FACE, BLACK CORE, ENGRAVED WITH EQUIPMENT IDENTIFICATION AND ATTACHED TO EQUIPMENT WITH SELF-TAPPING SCREWS. CHEMICAL ADHESION PLATES ARE NOT ACCEPTABLE. LETTERS SHALL BE MINIMUM 1/4" (6mm) HIGH.
- LABELS SHALL BE EMBOSSED PLASTIC WITH MINIMUM 1/4" (6mm) HIGH LETTERS. LABELS SHALL BE USED FOR IDENTIFYING CONDUIT, CABLES, JUNCTION BOXES, RECEPTACLES, ETC.
- WORDING ON NAMEPLATES AND LABELS MUST BE APPROVED BY THE ENGINEER PRIOR TO MANUFACTURING.

260520 CONDUCTORS AND CONNECTORS

- UNLESS NOTED OTHERWISE, ALL CONDUCTORS SHALL BE COPPER, MINIMUM SIZE #12 AWG, WITH THERMOPLASTIC OR CROSS-LINKED POLYETHYLENE INSULATION CONFORMING TO THE APPLICABLE LOCAL ELECTRICAL CODE. INSULATION SHALL BE RATED FOR 90°C. CONDUCTORS SHALL BE COLOR CODED IN ACCORDANCE WITH THE LOCAL ELECTRICAL CODE.
- UNLESS NOTED OTHERWISE, ALL CONDUCTORS USED FOR GROUNDING SHALL BE COPPER AND SHALL HAVE GREEN INSULATION.
- FOR COPPER CONDUCTORS #6 AWG AND SMALLER USE 3M SCOTCH-LOK OR T&B STA-KON COMPRESSION TYPE CONNECTORS WITH INTEGRAL OR SEPARATE INSULATION CAPS. FOR COPPER CONDUCTORS LARGER THAN #6 AWG USE SOLDERLESS, IDENT HEX SCREW OR BOLT TYPE PRESSURE CONNECTORS OR DOUBLE COMPRESSION C-CLAMP CONNECTORS, UNLESS SPECIFIED OTHERWISE ON DRAWINGS.
- UNLESS NOTED OTHERWISE, ALL LUGS SHALL BE TIN PLATED COPPER, TWO-HOLE, LONG BARREL, COMPRESSION TYPE.
- CONDUCTOR LENGTHS SHALL BE CONTINUOUS FROM TERMINATION TO TERMINATION WITHOUT SPLICES. SPLICES ARE NOT ACCEPTABLE. IF SPLICES ARE UNAVOIDABLE PRIOR APPROVAL FROM THE ENGINEER MUST BE OBTAINED.

262823 SAFETY SWITCHES AND PROTECTIVE DEVICES

- ENCLOSED, NON-FUSIBLE AND FUSIBLE SAFETY (DISCONNECT) SWITCHES SHALL BE CSA APPROVED, SIZED AS INDICATED ON DRAWINGS.
- UNLESS NOTED OTHERWISE, PROVIDE CLASS J TIME DELAY FUSES FOR MAIN FEEDERS; CLASS RK1 TIME DELAY FUSES FOR MOTOR CIRCUITS AND CLASS RK5 NON-TIME-DELAY FOR OTHER BRANCH CIRCUITS.
- PROVIDE TWO (2) SETS OF SPARE FUSES AND A FUSE CABINET FOR EACH LOCATION WHERE FUSES ARE INSTALLED.
- PROVIDE MOLDED CASE, BOLT-ON TYPE, AND THERMAL MAGNETIC TRIP CIRCUIT BREAKERS AS SHOWN AND AS REQUIRED FOR THIS PROJECT. MULTIPLE POLE BREAKERS SHALL BE SINGLE HANDLE, COMMON TRIP. PROVIDE HANDLE LOCKING DEVICES WHERE INDICATED. INTERRUPTING RATING TO MATCH REQUIRED AVAILABLE FAULT CURRENTS.

260534 RACEWAYS, CABLE RACKS AND BOXES

- ALL CONDUIT SHALL BE CSA APPROVED AND ULC LABELED.
- UNLESS NOTED OTHERWISE, CONDUIT INSTALLED ON THE EXTERIOR OF THE EQUIPMENT BUILDING IS PERMITTED TO BE RIGID PVC. CONDUIT INSIDE THE BUILDING IN AREAS WHERE SAFE FROM MECHANICAL DAMAGE SHALL BE EMT. CONDUIT IN AREAS OF RISK OF PHYSICAL DAMAGE SHALL BE RIGID STEEL.
- ALL EMPTY CONDUIT INSTALLED FOR FUTURE INSTALLATION OF WIRES AND CABLES SHALL HAVE A PULL CORD. PULL CORD SHALL BE LABELED AT BOTH ENDS FOR EASY IDENTIFICATION.
- ENCLOSURES AND CABINETS SHALL BE MADE OF STEEL BOX WITH REMOVABLE INTERIOR PANEL AND HINGED FRONT COVER, FINISHED INSIDE AND OUT WITH MANUFACTURER'S STANDARD ENAMEL. DOOR SHALL BE EQUIPPED WITH FLUSH LATCH AND CONCEALED HINGE. MANUFACTURERS: HOFFMANN, O-2/GEDNEY, T&B OR APPROVED EQUAL.

262400 SERVICE AND DISTRIBUTION

- VERIFY ALL DIMENSIONS AND CLEARANCES BY FIELD MEASUREMENTS BEFORE INSTALLATION.
- BRANCH CIRCUIT PANELBOARDS SHALL BE OF THE TYPE AND RATINGS AS SHOWN ON DRAWINGS.

263214 EMERGENCY POWER SYSTEM

- OWNER SUPPLIED WITH CONNECTIONS (HVAC/ELEC) AS PART OF THIS CONTRACT.

260528 GROUNDING

- ALL SAFETY GROUNDING OF THE ELECTRICAL EQUIPMENT SHALL BE CARRIED OUT IN ACCORDANCE WITH THE LATEST EDITION OF THE LOCAL ELECTRICAL CODE.
- ALL LIGHTNING PROTECTION SYSTEM GROUNDING SHALL BE CARRIED OUT IN ACCORDANCE WITH THE LATEST ISSUE OF CAN/CSA – B72.
- DC OR REFERENCE GROUNDING SHALL BE DONE IN ACCORDANCE WITH DC PLANT MANUFACTURER'S GROUNDING STANDARDS AND AS REQUIRED BY THE OWNER.
- MAINTAIN OWNER'S INSTRUCTIONS FOR ALL GROUNDING RELATED REQUIREMENTS.
- ALL INTERIOR GROUNDING AND BONDING CONDUCTORS SHALL BE CONNECTED USING HEAVY-DUTY COMPRESSION FITTINGS. MECHANICAL OR SOLDER TYPE CONNECTIONS ARE NOT PERMITTED.
- ALL GROUND BARS SHALL BE AS SHOWN ON THE DRAWINGS.
- IN ORDER TO MITIGATE HIGH FREQUENCY NOISE EFFECTIVELY THE GROUNDING CONDUCTORS SHALL BE RUN AS STRAIGHT AS POSSIBLE WITH MINIMUM NUMBER OF DIRECTION CHANGES. SHARP 90° BENDS OR KINKS ARE NOT PERMITTED. WHEN THE DIRECTION OF THE CONDUCTOR MUST CHANGE, IT SHALL BE DONE GRADUALLY. MINIMUM BENDING RADIUS OF GROUNDING CONDUCTORS OTHER THAN THE ELECTRICAL SAFETY GROUND CONDUCTORS SHALL BE AS FOLLOWS:

CONDUCTOR SIZE	MINIMUM BENDING RADIUS TO INSIDE EDGE
#12 AWG TO #8 AWG	3" (75mm)
#6 AWG TO #1/0 AWG	6" (150mm)
#2/0 AWG TO 750 KCMIL	12" (300mm)

- ALL GROUND LUG AND COMPRESSION CONNECTIONS SHALL BE COATED WITH ANTI-OXIDANT AGENT, SUCH AS NO-OX, NOALOX, PENETROX OR KOPRSIELD.

266000 TESTING AND COMMISSIONING

- CARRY OUT TESTING AND COMMISSIONING OF ALL MAJOR ELECTRICAL EQUIPMENT SUCH AS DISTRIBUTION BOARDS, GENERATOR, AUTOMATIC TRANSFER SWITCH, MOTOR STARTERS ETC. ENGAGE THE SERVICES OF SUPPLIERS OF EQUIPMENT IN FACILITATING TESTING AND COMMISSIONING.
- COORDINATE ALL TESTING PROCEDURES AND TIMES WITH THE EQUIPMENT SUPPLIER.
- INCLUDE TESTING AND COMMISSIONING REPORTS IN THE OPERATIONS AND MAINTENANCE MANUALS.

DIVISION 28 – ELECTRONIC SAFETY AND SECURITY

281300 SECURITY SYSTEM

- SECURITY SYSTEM MANUFACTURER/SUPPLIER IS TO BE SELECTED BY THE OWNER DURING THE COURSE OF THE PROJECT.
- PROVIDE PULL CORD IN ALL EMPTY CONDUIT RUNS. LABEL PULL CORD AT BOTH ENDS FOR EASY IDENTIFICATION.
- OWNER'S SECURITY SYSTEM CONTRACTOR SHALL BE RESPONSIBLE FOR SUPPLY, INSTALLATION, TERMINATION, TESTING AND COMMISSIONING OF THE SECURITY SYSTEM.



A – INDICATES DETAIL NO.
B – INDICATED SHEET DETAIL IS REQUIRED
C – INDICATES SHEET DETAIL IS DRAWN

2	REVISED	28/10/2020	MH	RB
1	ISSUED FOR CONSTRUCTION	17/06/19	JS	RN
0	ISSUED FOR TENDER	16/08/17	JS	RN
no. no	revision revision	date date	by par	approved approve

Project – projet
MCTS GENERATOR BLDG
ST. LAWRENCE

Drawing – dessin
ELECTRICAL NOTES

drawn – dessine	J.S.	designed – dessine par	M.M.
date – date	MAY 2017	checked – vérifie	R.N.
scale – echelle	AS SHOWN	approved for tender – approuve pour l'offre	R.N.
project no. – projet no.	drawing no. – no du dessin	sheet – feuille	
	01L1402B02916–N3	16 OF 16	