

S14GT SPLITTER (FOO-FSA-AAA-ATZ)

4 Port Ruggedized GPS Splitter

DESCRIPTION

The S14GT FOO-FSA-AAA-ATZ has been specifically designed for rugged applications. Built to withstand extreme conditions in vehicular applications, the S14GT makes it possible to use a single GPS antenna and cable arrangement for multiple critical systems.

The S14GT FOO-FSA-AAA-ATZ features an antenna DC bias select circuit. This allows for the active antenna DC input to be applied to any or all RF outputs. With this feature, one DC voltage will be chosen to power the antenna while other inputs will be switched to DC blocked outputs with 200 Ohm resistive loads to ground. Designed for redundancy, if the selected DC bias input should fail or is removed, the DC bias will automatically switch to another DC input to ensure an uninterrupted supply to the active antenna.

The S14GT FOO-FSA-AAA-ATZ includes the EMI shielding and hermetically sealed options standard, to provide increased reliability. This is a unity gain (-A00) amplified device such that the power level at all four outputs is the same power level as the signal level at its input.



FEATURES

- EMI Shielding
- Hermetically Sealed
- Amplified to Offset Splitter Losses
- Standard Antenna DC Bias Select
- RoHS/REACH/WEEE Compliant

1 S14GT Electrical Specifications

Table 1-1. Electrical Specifications

Operating Temperature -40°C to 85°C

Parameter	Conditions	Min	Typ	Max	Units
Frequency Range	Ant: Any Port; Unused Ports: 50Ω	1.1		1.7	GHz
Gain	00dB Ant: Any Port; Unused Ports: 50Ω	-3	0	+3	dB
Input/Output SWR	All Ports 50Ω		2:0:1		—
Noise Figure	Ant: Any Port; Unused Ports: 50Ω, Gain = 0dB			2	dB
Gain Compression Point (IP1dB)	Gain = 0dB	-35			dBm
3rd Order Intercept (IIP3) (Gain = 0dB)	f1 = 1600.42MHz f2 = 1625.42MHz 2f1 - f1 = fL1	-24			dBm
RF Input (Damage Threshold)	Max RF Input Without Damage			0	dBm
Amp. Balance	[J1 – J2] Ant: Any Port; Unused Ports: 50Ω			1	dB
Phase Balance	Phase (J1 – J2) Ant: Any Port; Unused Ports: 50Ω			1	Degree
Delay - Amplified	Ant: Any Port; Unused Ports: 50Ω, L1			5	ns
Isolation - Amplified (Gain = 0dB)	Adjacent Ports: Ant – 50Ω	30			dB
	Opposite Ports: Ant – 50Ω	40			dB
DC IN	DC Input on any RF Output	3.3		12	VDC
Device Current	Current Consumption of Active Device (excludes Ant. Cur.)		18	20	mA
Ant/Thru Current ⁽¹⁾	Max Source DC Current Through Device			250	mA

1. Maximum current available from the DC source through the S14GT when output of S14GT is short circuited.

2 Performance Data

2.1

Figure 2-1. Frequency Response (0dB)

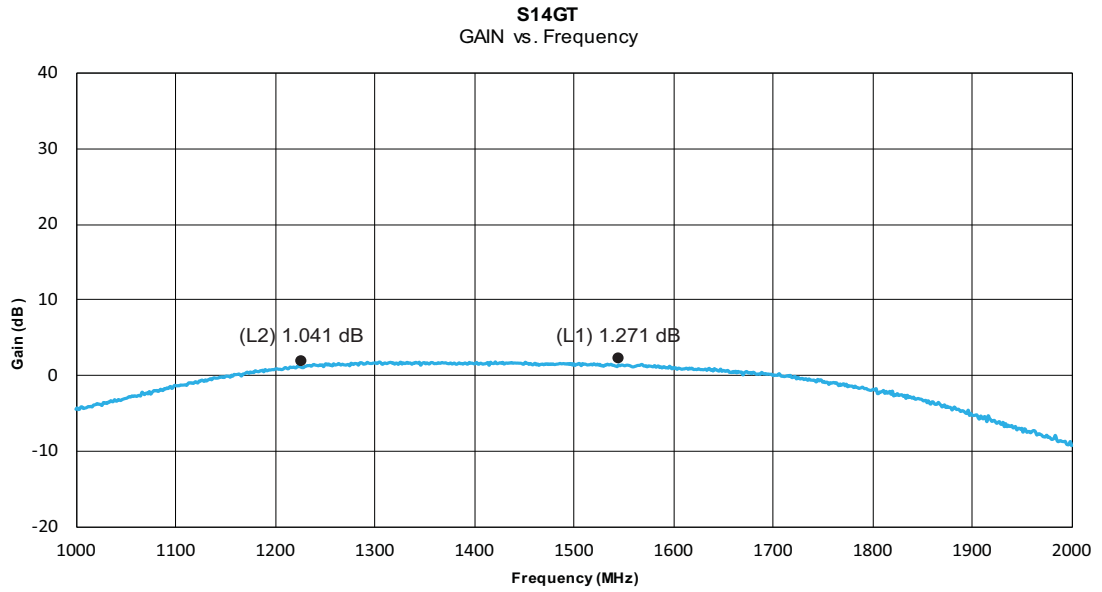

Figure 2-2. Input SWR (0dB)

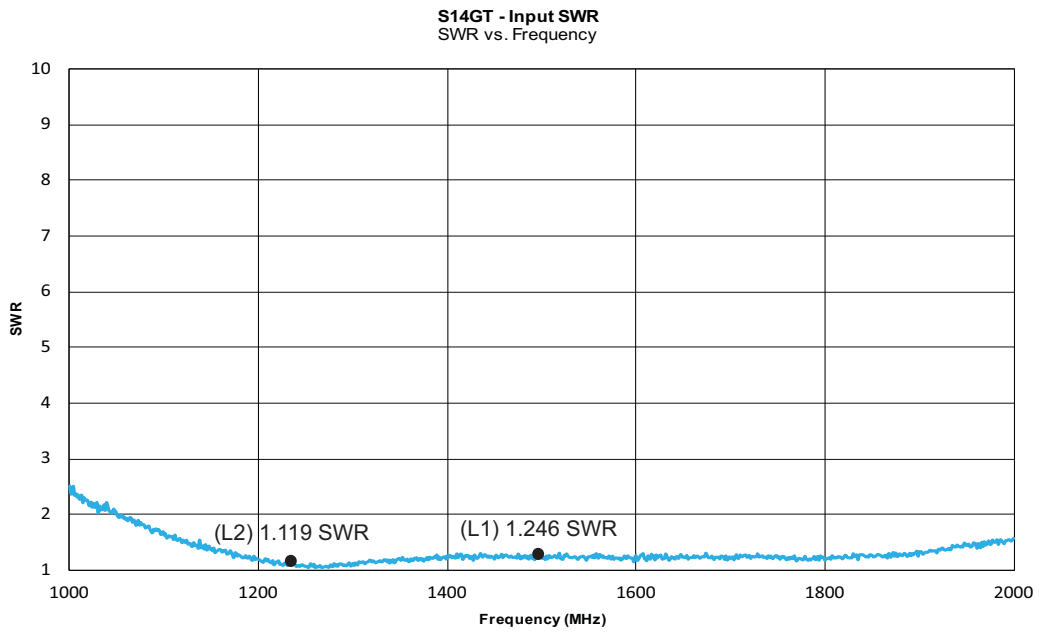
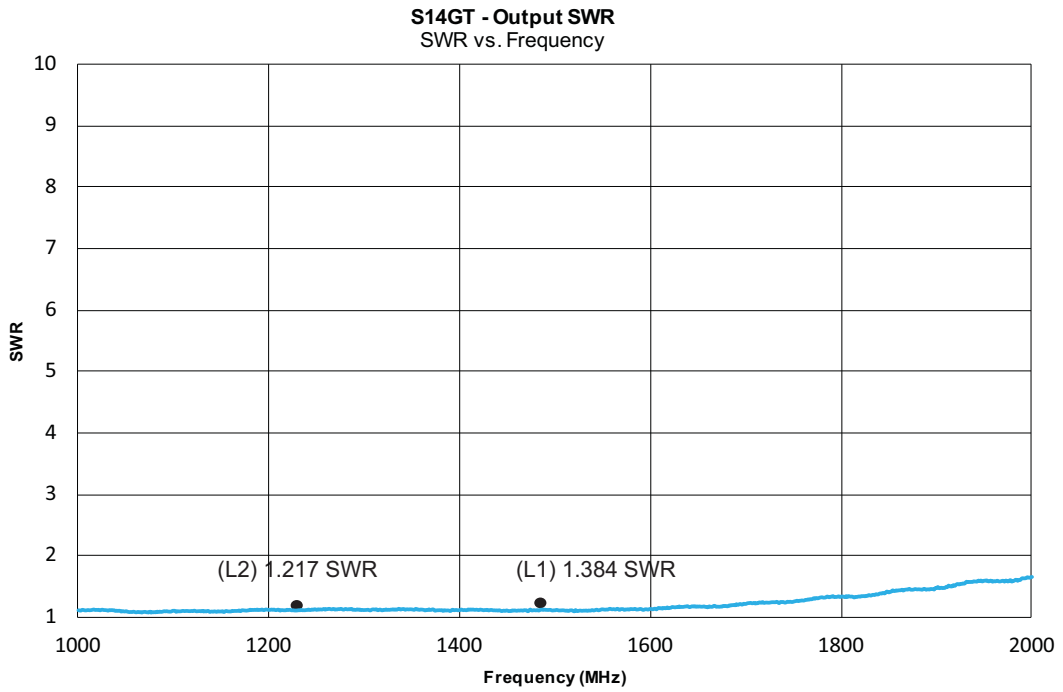

Figure 2-3. Output SWR (0dB)



3 Operational Description

3.1 RF Signal Processing System

The RF signal processing system consists fundamentally of amplification stages and classical Wilkinson Splitter elements which divide the RF signal from the antenna input evenly between four RF output ports. The standard gain is 00dB.

3.2 Gain Option

In the Amplified High Isolation Configuration (standard 00dB), 50 Ω signal attenuators are in the RF output paths to provide additional isolation between each RF port. The S14GT does not require 50 Ω terminations on unused ports in order for the splitter to operate correctly. This standard configuration is chosen if it is possible for spurious emissions from one GPS receiver on one port of the splitter to cause interference with GPS receivers connected to other output ports.

To some extent, the port-to-port isolation performance is a function of the input-to-output gain. The port-to-port isolation is maximized when the gain is 00dB.

3.3 Antenna DC Bias Select

GPS Source RF signal splitters are unique relative to other generic RF signal splitters as they typically operate in conjunction with an active GPS antenna (a GPS antenna that includes an integrated Low Noise Amplifier). Consequently, a GPS RF signal splitter must have provisions for managing the DC voltage to the active GPS antenna.

The S14GT splitter requires a DC voltage be applied to one or more of the RF output ports by way of the RF connector center conductor. If DC voltages are applied to more than one of the RF output ports, the S14GT DC bias select circuit will choose one of these DC inputs to power the active circuitry of the S14GT and will also pass this DC voltage through the splitter to the center conductor of the RF input port. Ports without an external DC voltage applied, or from which an external DC voltage is removed, are internally pulled-down to ensure that the false input voltage indications do not occur. The DC voltage available on the RF input port can be used to power the application's active antenna.

The DC voltages applied to the RF outputs that are not chosen by the DC bias select circuitry will automatically switch through an RF choke to 200 Ω DC loads. The DC bias select circuit will always select the DC voltage on the lowest numbered RF port that has a DC voltage applied to power the S14GT and the application's antenna. If the chosen DC input is removed or fails, the DC bias select circuit will automatically switch to the next higher numbered RF port to which a DC voltage is applied.

Example 1: Assume DC voltages are applied to RF outputs 1, 3, and 4. In this scenario, the DC voltage on port 1 will be used to power the S14GT and the application antenna. Ports 3 and 4 will be switched to 200 Ω DC loads.

Example 2: Now assume the DC voltage on port 1 is removed. The S14GT will automatically terminate the input internally with a pull-down resistor and switch the operation of the splitter and antenna to the DC voltage applied to the next high numbered port with a DC voltage applied, port 3. Port 4 will remain switched to a 200 Ω load.

4 S14GT Connection

To install the S14GT, connect the coaxial cable feeding the active GPS antenna prior to connecting the RF outputs. Once the antenna coaxial cable is attached, coaxial cables with or without DC voltages can be connected to the outputs.



At least one coaxial cable connected to any output of the device must provide a DC voltage suitable for operating the active GPS antenna and the S14GT.

5 Certifications and Approvals

Certifications and Approvals	
EMC/Emissions	FCC part 15B and R&TTE equivalent
Safety/Low Voltage	EN60950-1
Environmental	IEC 60529, IP55 (Optional) <i>Note: Not currently qualified to MIL-STD 810G.</i>

6 Product Code Decoder

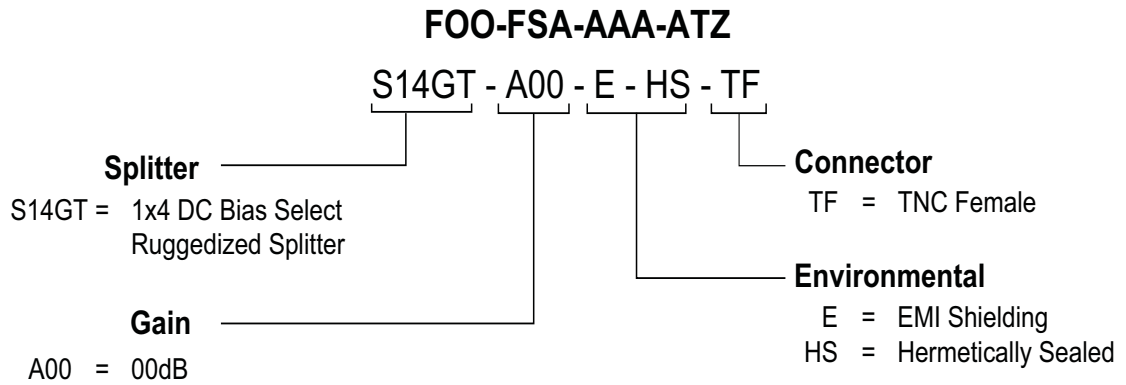

Note: To have product/part codes customized to meet exact needs, contact GPS Source at GPSS-Sales@gd-ms.com or visit the website at www.gpssource.com.

7 Mechanical Drawing

S14GT — Ruggedized 1x4 Splitter

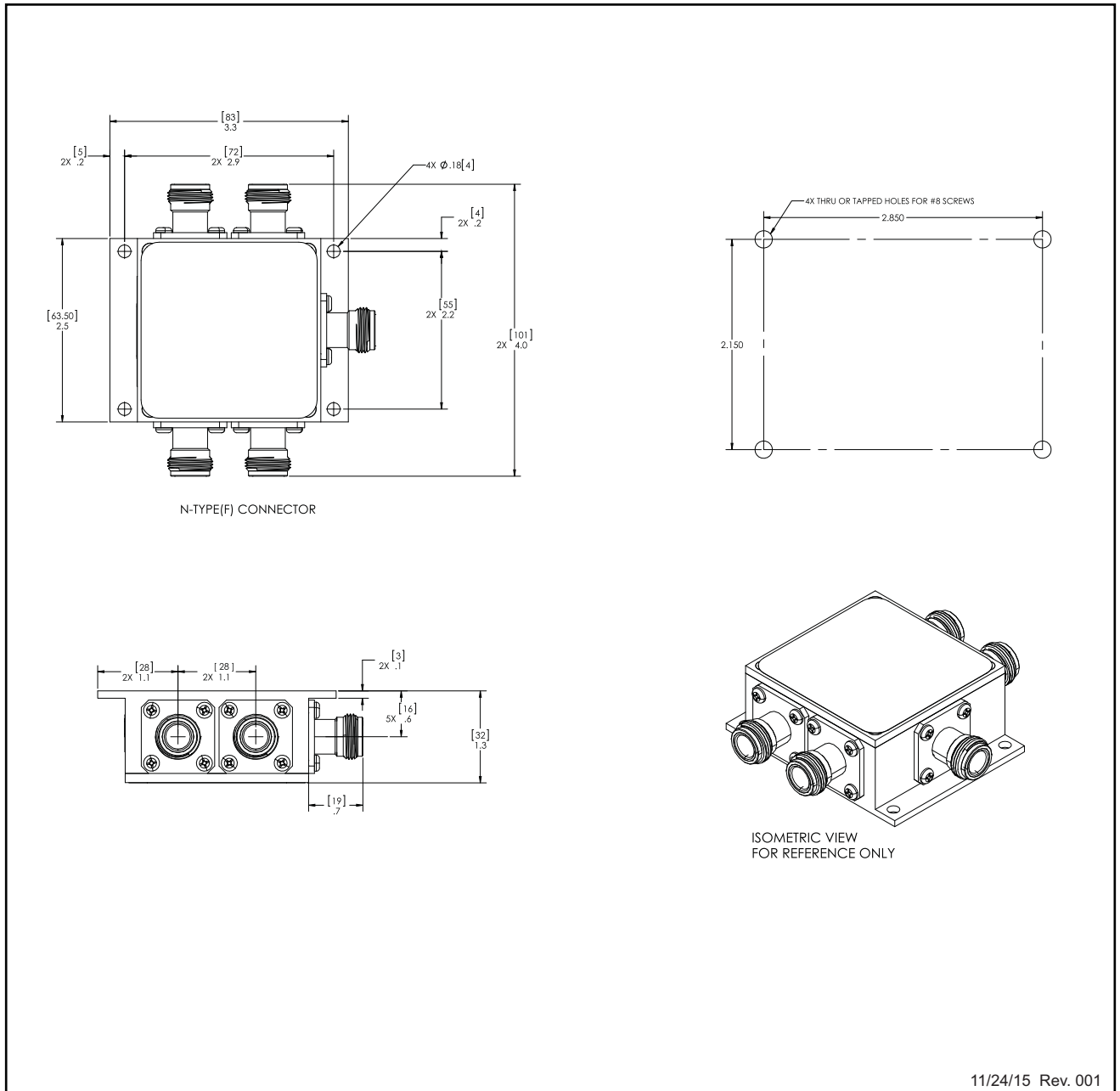

11/24/15 Rev. 001

GPS Source Part No. FOO-FSA-AAA-ATZ	Finish N/A	Size C	Mass	Tolerances	
Description S14GT RUGGEDIZED W/DC BIAS SELECT	Material N/A	3 rd Angle Projection 		Linear .X = ±0.100 .XX = ±0.010	Angular ±1° RADII See Linear
All materials and finishes shall comply with European Union RoHS and are lead free. Dimensions are in inches unless otherwise specified.					

S14GT Data Sheet

059-FOO-FSA-AAA-ATZ-001

Page 9 of 9, 04/17/2020



2121 Executive Cir., Ste 100
Colorado Springs, CO 80905
Phone: (+1)(719) 421.7300
Toll Free: (+1)(866) 289.4777
GPSS-Sales@gd-ms.com
www.gpssource.com

AS9100 and ISO 9001 Compliant Company



© 2017 GPS Source, Inc. All rights reserved.

GPS Source, Inc., GPS Live Inside, GPS Source logo, and other GPS Source, Inc. products, brands, and trademarks mentioned in this document are property of GPS Source, Inc. and/or its affiliates in the United States and/or other countries. Other products, brands, and trademarks are property of their respective owners/companies. Any rights not expressly granted herein are reserved.

DISCLAIMER: The materials in this document could include inaccuracies or typographical errors and are subject to change at any time. The materials are provided "as is" without warranty of any kind. To the maximum extent permitted by applicable law, GPS Source, Inc. and its suppliers hereby disclaim all warranties, either expressed or implied, and conditions with respect to the materials, their quality, performance, suitability, merchantability, fitness for a particular purpose, title, and non-infringement. LIMITATION OF LIABILITY: IN NO EVENT WILL GPS SOURCE, INC. AND ITS SUPPLIERS BE LIABLE FOR INDIRECT, SPECIAL, INCIDENTAL, OR CONSEQUENTIAL DAMAGES, WHETHER IN AN ACTION OF CONTRACT OR TORT, ARISING OUT OF THE USE OR INABILITY TO USE THE MATERIALS AVAILABLE IN THIS DOCUMENT, EVEN IF ADVISED OF THE POSSIBILITY OF SUCH DAMAGES. IN PARTICULAR AND WITHOUT LIMITATION, GPS SOURCE, INC. SHALL HAVE NO LIABILITY FOR ANY LOSS OF USE, DATA, INCLUDING THE COSTS OF RECOVERING SUCH DATA, OR PROFITS.