

KEY PLAN - KENT
SCALE 1:5000

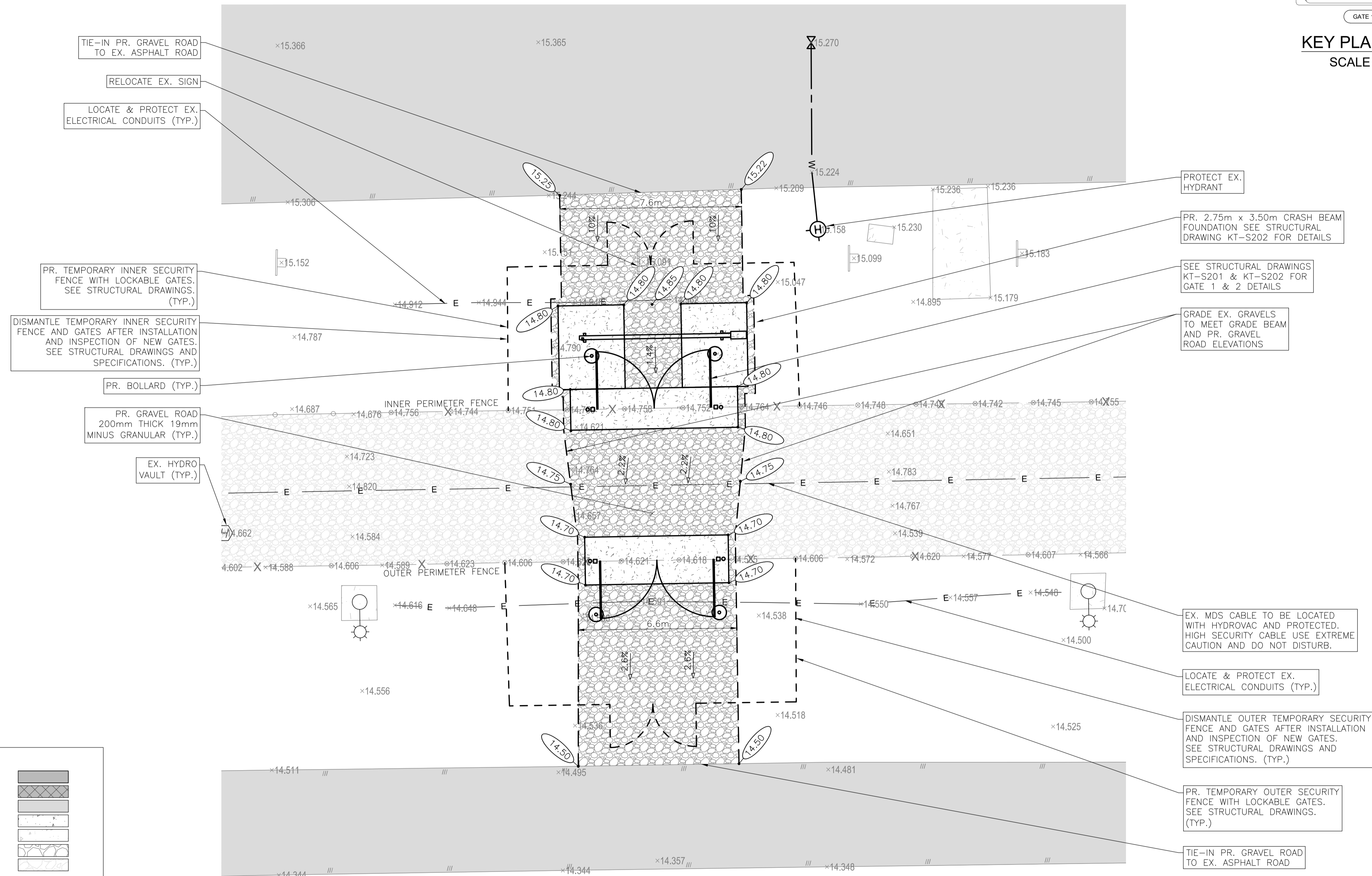

GATES 1 & 2
SCALE 1:100

LEGEND	
PR. ASPHALT	
PR. ASPHALT OVER MDS	
EX. ASPHALT	
PR. CONCRETE	
EX. CONCRETE	
PR. GRAVEL	
EX. GRAVEL	
EX. ELECTRICAL	E
EX. GAS	G
EX. DRAINAGE	D
EX. WATER	W
EX. SANITARY	S
EX. FENCE LINE	X
EX. EDGE OF PAVEMENT	
EX. FENCE POST	
EX. EDGE OF BUILDING	
EX. VALVE	
EX. STREET LIGHT	
EX. UTILITY POLE	
EX. SIGN	
PR. ELEVATION	•XX.XX
PR. GRADING	X.X%

Revision/	Description/Description	Date/Date
5	ISSUED FOR TENDER	201106

Client/client

CORRECTIONAL SERVICE CANADA

Project title/Titre du projet

PACIFIC REGION PERIMETER FENCE UPGRADES

Consultant Signature Only

Designed by/Concept par
S. VERKAIK

Drawn by/Dessiné par
T. ASHBURY

PWGC Project Manager/Administrateur de Projets TPSGC
DARYL SINCLAIR / TONY TANG

Regional Manager, Architectural and Engineering Services
Gestionnaire régionale, Services d'architectural et de génie, TPSGC
PREETIPAL PAUL

Drawing title/Titre du dessin

KENT INSTITUTION
GATE 1 & 2

Project No./No. du projet	Sheet/ Feuille	Revision no./ La Révision no.
R.071529.001	KT-C301	5



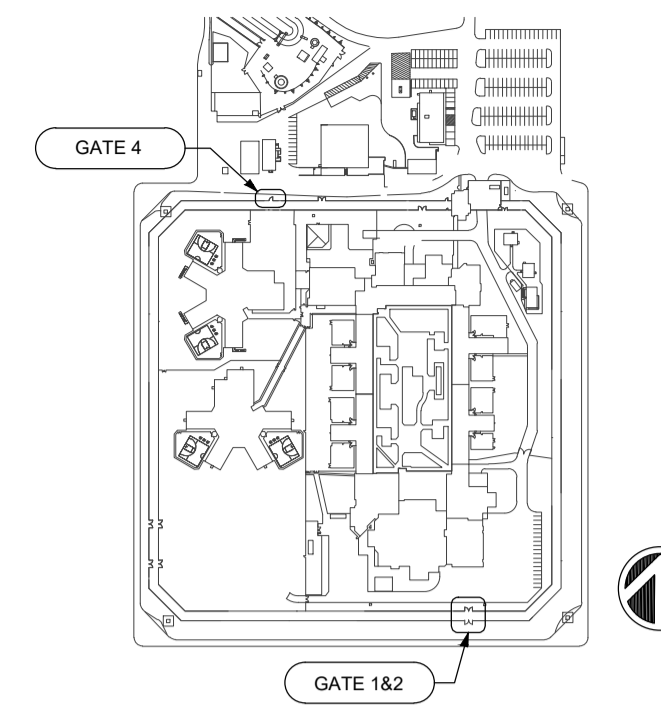
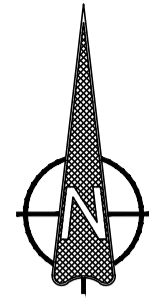

KEY PLAN - KENT
SCALE 1:5000

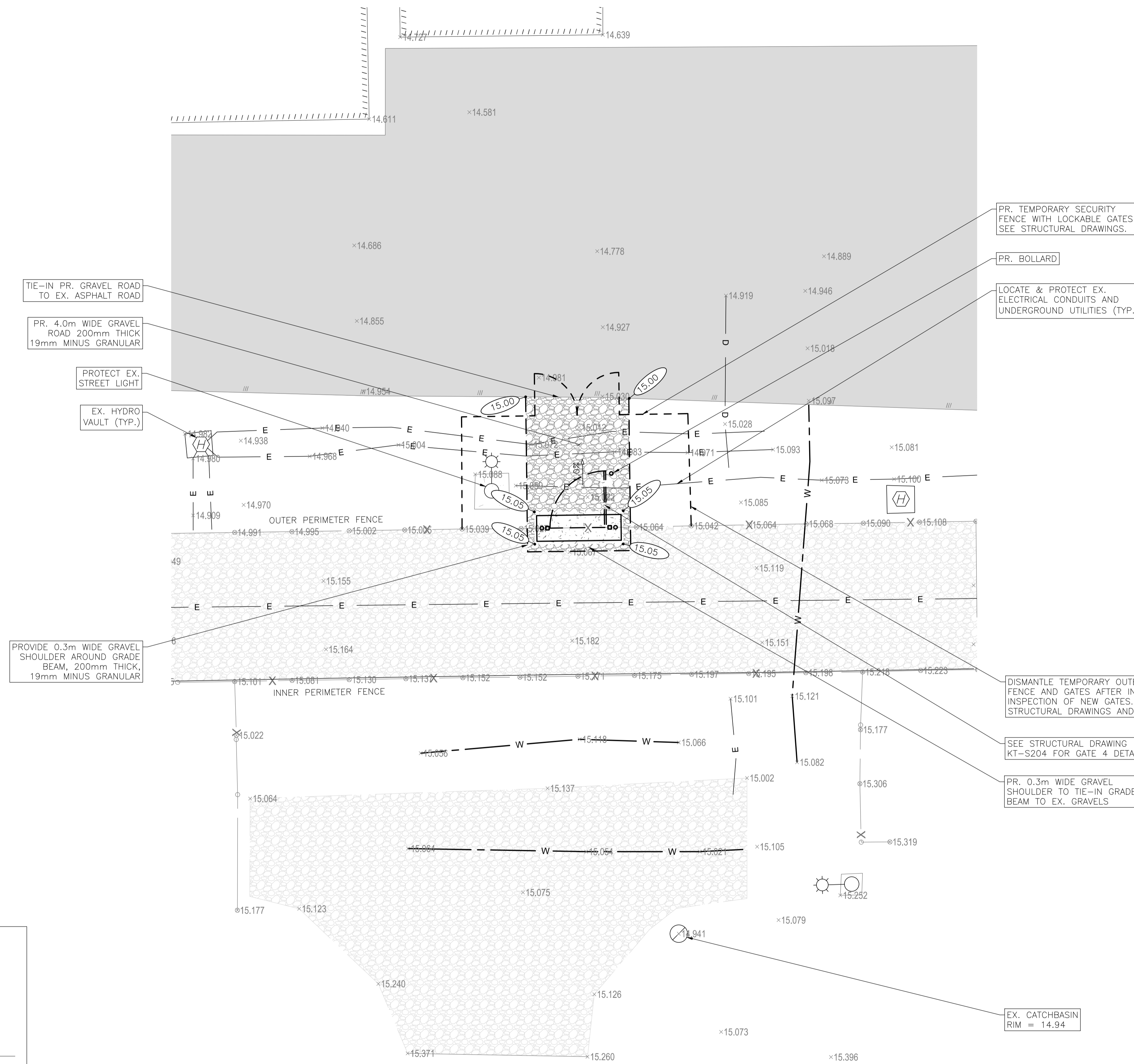

GATE 4
SCALE 1:100

LEGEND	
PR. ASPHALT	
PR. ASPHALT OVER MDS	
EX. ASPHALT	
PR. CONCRETE	
EX. CONCRETE	
PR. GRAVEL	
EX. GRAVEL	
EX. ELECTRICAL	E
EX. GAS	G
EX. DRAINAGE	D
EX. WATER	W
EX. SANITARY	S
EX. FENCE LINE	X
EX. EDGE OF PAVEMENT	
EX. FENCE POST	
EX. EDGE OF BUILDING	
EX. VALVE	
EX. STREET LIGHT	
EX. UTILITY POLE	
EX. SIGN	
PR. ELEVATION	•XX.XX
PR. GRADING	X.X%



5	ISSUED FOR TENDER	2011/06
---	-------------------	---------

Revision/	Description/Description	Date/Date
5	ISSUED FOR TENDER	2011/06

Client/client
CORRECTIONAL SERVICE CANADA

Project title/Titre du projet
PACIFIC REGION PERIMETER FENCE UPGRADES

Consultant Signature Only

Designed by/Concept par
S. VERKAJK

Drawn by/Dessiné par
T. ASHBURY

PWGSC Project Manager/Administrateur de Projets TPSGC
DARYL SINCLAIR / TONY TANG

Regional Manager, Architectural and Engineering Services
Gestionnaire régionale, Services d'architectural et de génie, TPSGC
PREETIPAL PAUL

Drawing title/Titre du dessin
KENT INSTITUTION GATE 4

Project No./No. du projet R.071529.001	Sheet/Feuille KT-C302	Revision no./La Révision no. 5
--	---------------------------------	--



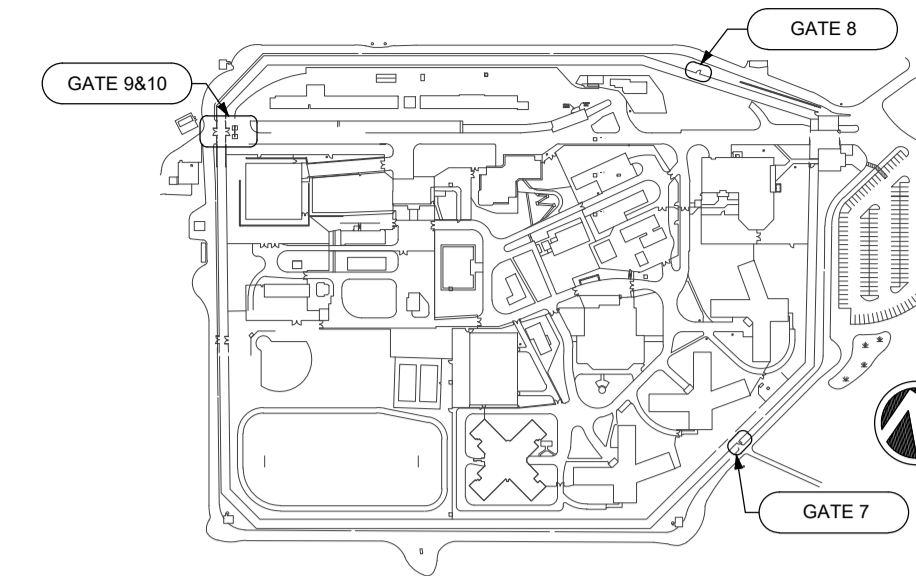
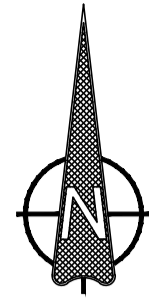

KEY PLAN - MOUNTAIN
SCALE 1:5000

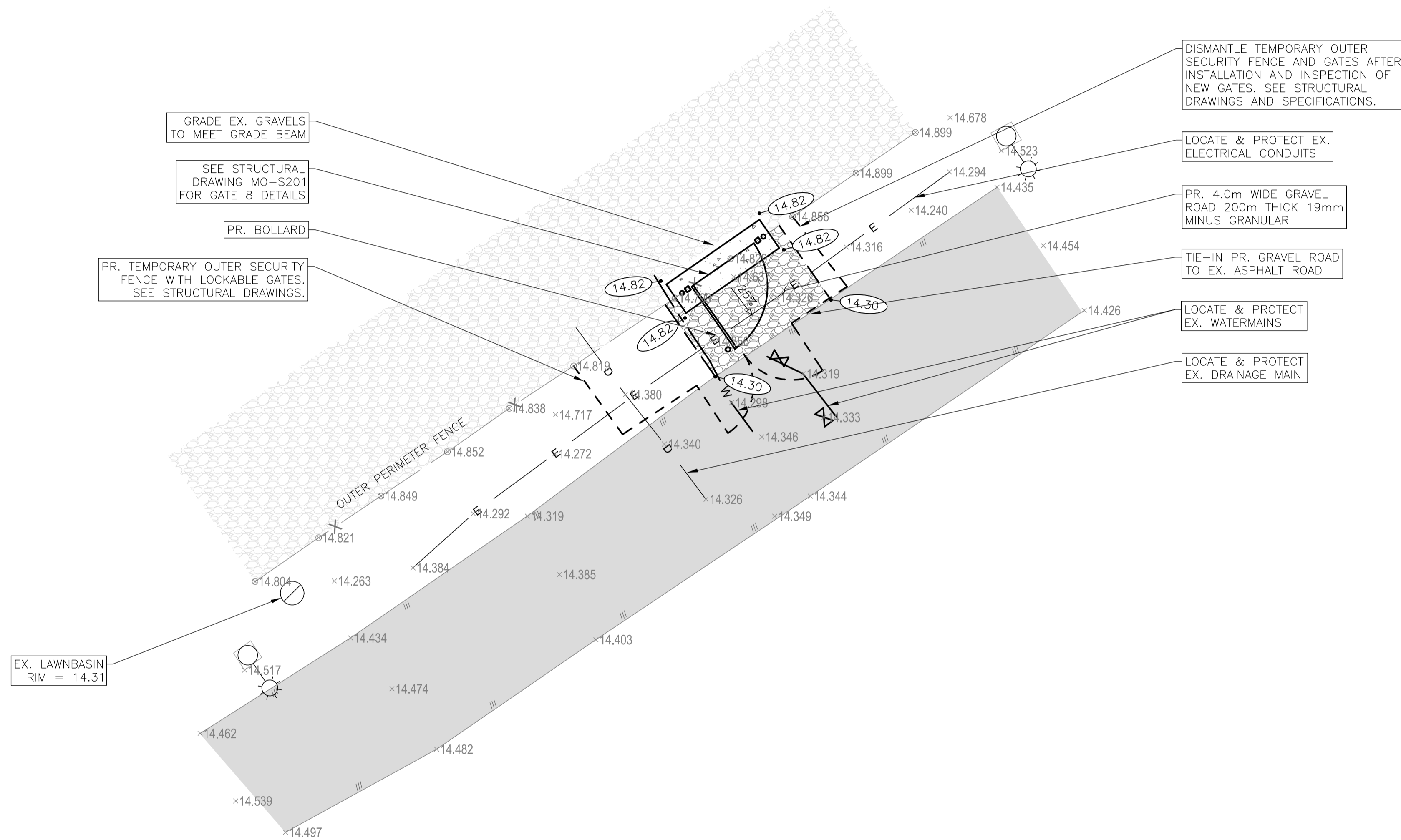

GATE 7
SCALE 1:100

LEGEND	
PR. ASPHALT	
PR. ASPHALT OVER MDS	
EX. ASPHALT	
PR. CONCRETE	
EX. CONCRETE	
PR. GRAVEL	
EX. GRAVEL	
EX. ELECTRICAL	E
EX. GAS	G
EX. DRAINAGE	D
EX. WATER	W
EX. SANITARY	S
EX. FENCE LINE	X
EX. EDGE OF PAVEMENT	
EX. FENCE POST	
EX. EDGE OF BUILDING	
EX. VALVE	
EX. STREET LIGHT	
EX. UTILITY POLE	
EX. SIGN	
PR. ELEVATION	•XXX.XX
PR. GRADING	X.XX%



Revision/Revision	Description/Description	Date/Date
5	ISSUED FOR TENDER	201106

Client/client

CORRECTIONAL SERVICE CANADA

Project title/Titre du projet

PACIFIC REGION PERIMETER FENCE UPGRADES

Consultant Signature Only

Designed by/Concept par
S. VERKAIK

Drawn by/Dessiné par
T. ASHBURY

PWGC Project Manager/Administrateur de Projets TPSGC
DARYL SINCLAIR / TONY TANG

Regional Manager, Architectural and Engineering Services
Gestionnaire régionale, Services d'architectural et de génie, TPSGC
PREETIPAL PAUL

Drawing title/Titre du dessin

**MOUNTAIN INSTITUTION
GATE 7**

Project No./No. du projet	Sheet/Feuille	Revision no./La Révision no.
R.071529.001	MO-C301	5

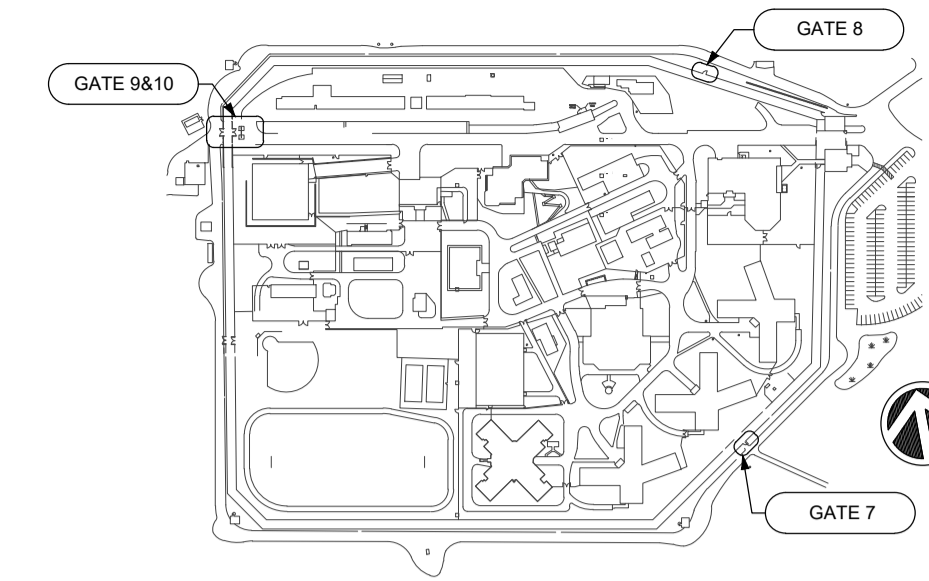
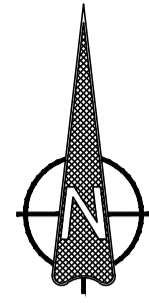

KEY PLAN - MOUNTAIN
SCALE 1:5000

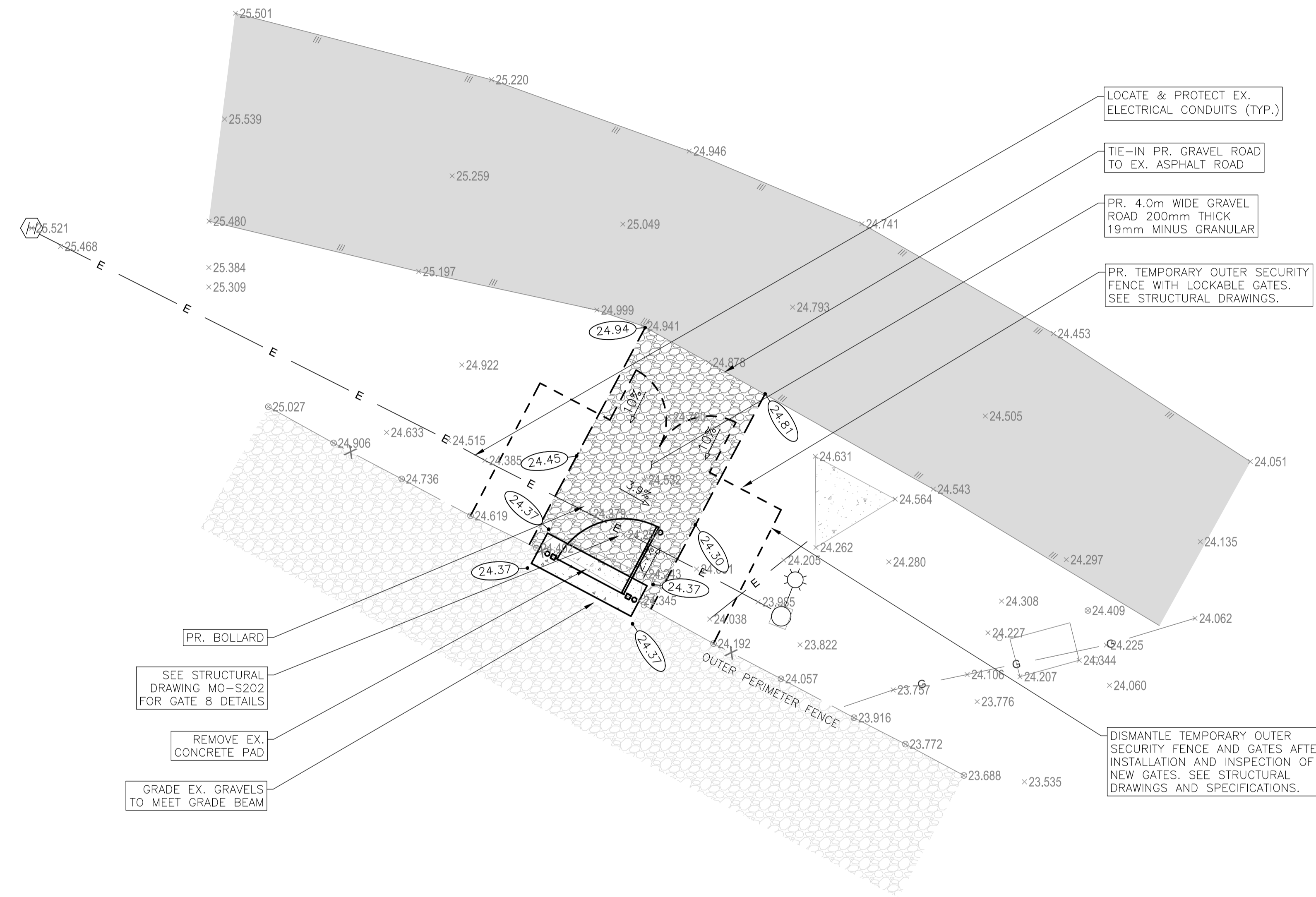

GATE 8
SCALE 1:100

LEGEND	
PR. ASPHALT	
PR. ASPHALT OVER MDS	
EX. ASPHALT	
PR. CONCRETE	
EX. CONCRETE	
PR. GRAVEL	
EX. GRAVEL	
EX. ELECTRICAL	E
EX. GAS	G
EX. DRAINAGE	D
EX. WATER	W
EX. SANITARY	S
EX. FENCE LINE	X
EX. EDGE OF PAVEMENT	
EX. FENCE POST	
EX. EDGE OF BUILDING	
EX. VALVE	
EX. STREET LIGHT	
EX. UTILITY POLE	
EX. SIGN	
PR. ELEVATION	XX.XX
PR. GRADING	X.X%

Revision/Revision	Description/Description	Date/Date
5	ISSUED FOR TENDER	201106

Client/client

CORRECTIONAL SERVICE CANADA

Project title/Titre du projet

PACIFIC REGION PERIMETER FENCE UPGRADES

Consultant Signature Only

Designed by/Concept par
S. VERKAJK

Drawn by/Dessiné par
T. ASHBURY

PWGSC Project Manager/Administrateur de Projets TPSGC
DARYL SINCLAIR / TONY TANG

Regional Manager, Architectural and Engineering Services
Gestionnaire régionale, Services d'architectural et de génie, TPSGC
PREETIPAL PAUL

Drawing title/Titre du dessin

MOUNTAIN INSTITUTION
GATE 8

Project No./No. du projet	Sheet/Feuille	Revision no./La Révision no.
R.071529.001	MO-C302	5



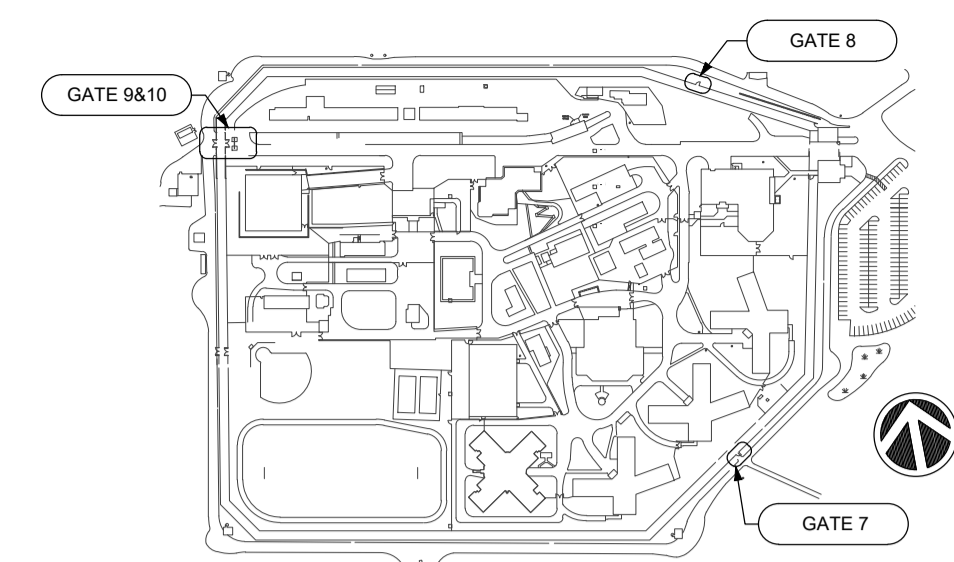

SCALE 1:5000
KEY PLAN - MOUNTAIN

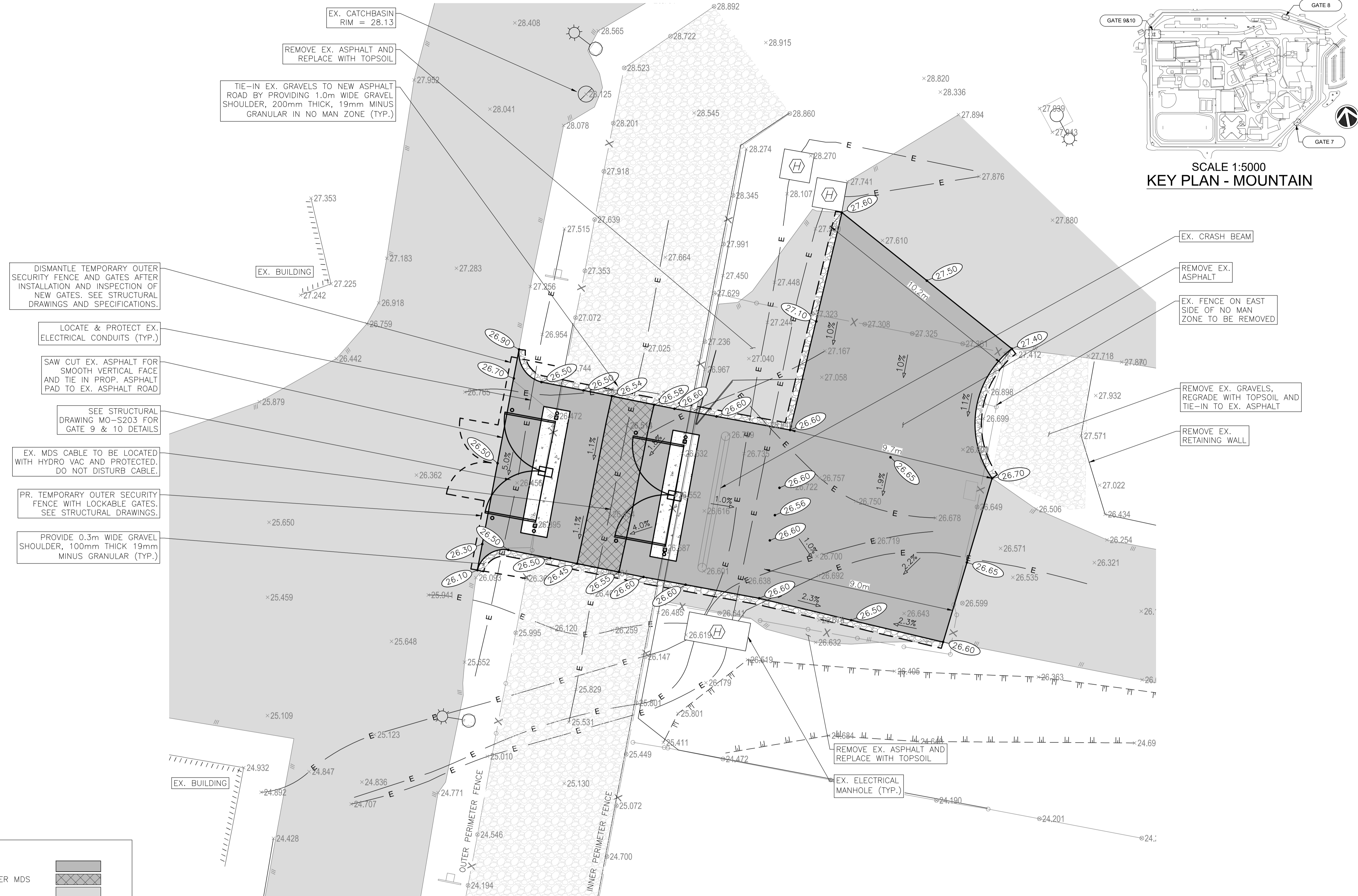

- DISMANTLE TEMPORARY OUTER SECURITY FENCE AND GATES AFTER INSTALLATION AND INSPECTION OF NEW GATES. SEE STRUCTURAL DRAWINGS AND SPECIFICATIONS.
- LOCATE & PROTECT EX. ELECTRICAL CONDUITS (TYP.)
- SAW CUT EX. ASPHALT FOR SMOOTH VERTICAL FACE AND TIE IN PROP. ASPHALT PAD TO EX. ASPHALT ROAD
- SEE STRUCTURAL DRAWING MO-S203 FOR GATE 9 & 10 DETAILS
- EX. MDS CABLE TO BE LOCATED WITH HYDRO VAC AND PROTECTED. DO NOT DISTURB CABLE.
- PR. TEMPORARY OUTER SECURITY FENCE WITH LOCKABLE GATES. SEE STRUCTURAL DRAWINGS.
- PROVIDE 0.3m WIDE GRAVEL SHOULDER, 100mm THICK 19mm MINUS GRANULAR (TYP.)

- EX. CRASH BEAM
- REMOVE EX. ASPHALT
- EX. FENCE ON EAST SIDE OF NO MAN ZONE TO BE REMOVED
- REMOVE EX. GRAVELS, REGRADE WITH TOPSOIL AND TIE-IN TO EX. ASPHALT
- REMOVE EX. RETAINING WALL



5	ISSUED FOR TENDER	201106
Revision/	Description/Description	Date/Date

Client/client
CORRECTIONAL SERVICE CANADA

Project title/Titre du projet
PACIFIC REGION PERIMETER FENCE UPGRADES

Consultant Signature Only
Designed by/Concept par: **S. VERKAIK**
Drawn by/Dessiné par: **T. ASHBURY**
PWGSC Project Manager/Administrateur de Projets TPSGC: **DARYL SINCLAIR / TONY TANG**
Regional Manager, Architectural and Engineering Services / Gestionnaire régionale, Services d'architectural et de génie, TPSGC: **PREETIPAL PAUL**

Drawing title/Titre du dessin
MOUNTAIN INSTITUTION GATE 9 & 10

Project No./No. du projet R.071529.001	Sheet/Feuille MO-C303	Revision no./La Révision no. 5
--	---------------------------------	--

LEGEND

PR. ASPHALT	
PR. ASPHALT OVER MDS	
EX. ASPHALT	
PR. CONCRETE	
EX. CONCRETE	
PR. GRAVEL	
EX. GRAVEL	
EX. ELECTRICAL	
EX. GAS	
EX. DRAINAGE	
EX. WATER	
EX. SANITARY	
EX. FENCE LINE	
EX. EDGE OF PAVEMENT	
EX. FENCE POST	
EX. EDGE OF BUILDING	
EX. VALVE	
EX. STREET LIGHT	
EX. UTILITY POLE	
EX. SIGN	
PR. ELEVATION	
PR. GRADING	

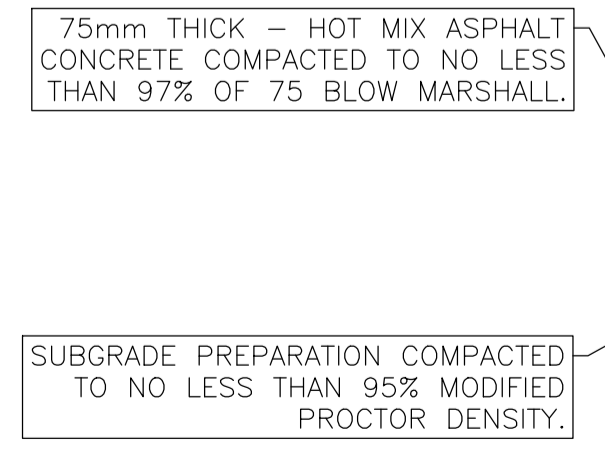

TYPICAL ASPHALT PAVEMENT STRUCTURE
SCALE: NTS

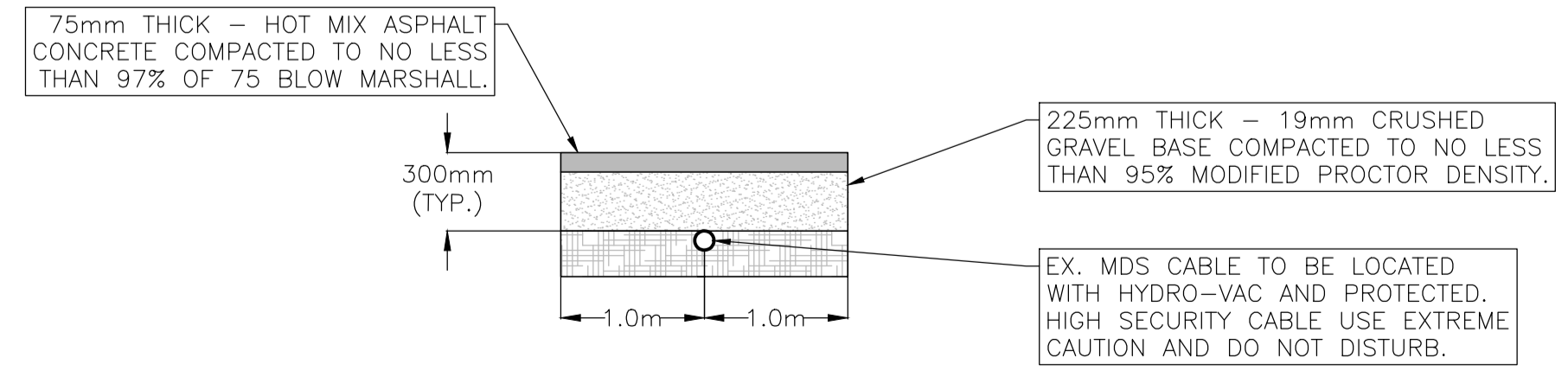

ASPHALT PAVEMENT STRUCTURE OVER MDS CABLE
SCALE: NTS

GATE 9 & 10
SCALE 1:100



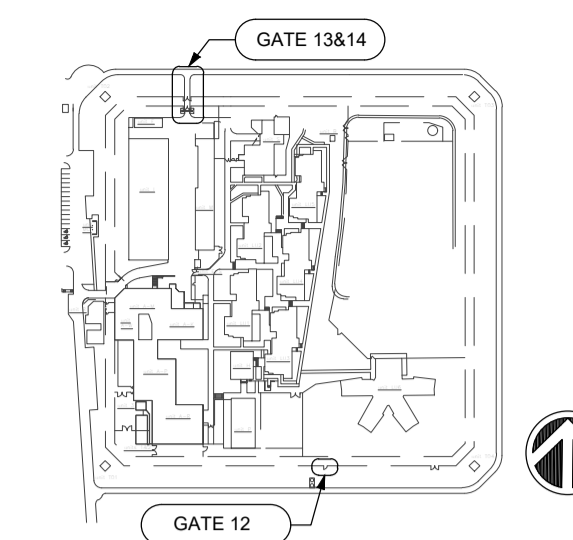
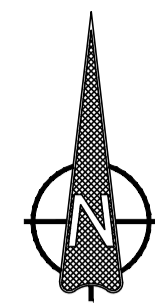

KEY PLAN - MISSION
SCALE 1:5000

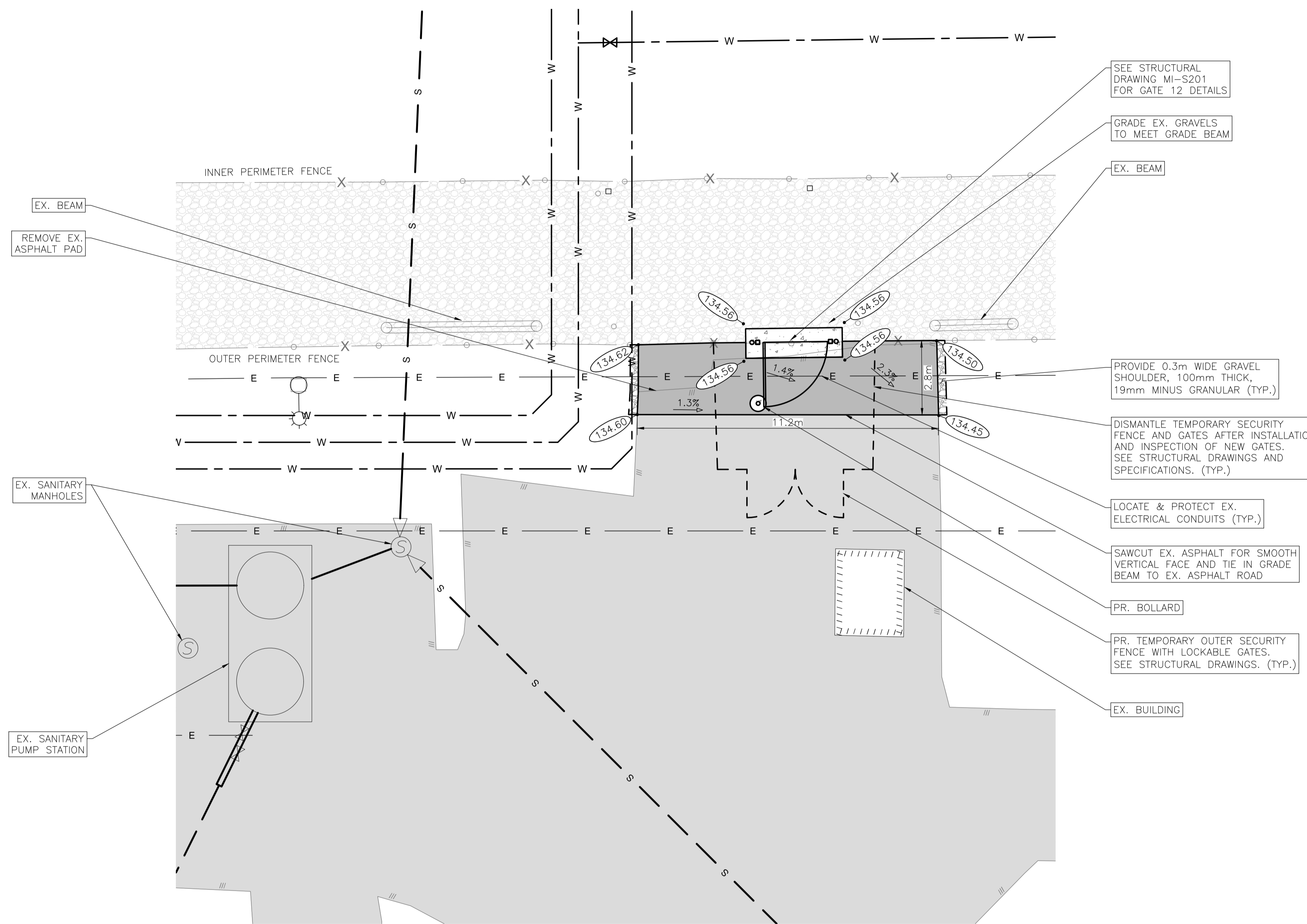

GATE 12
SCALE 1:100

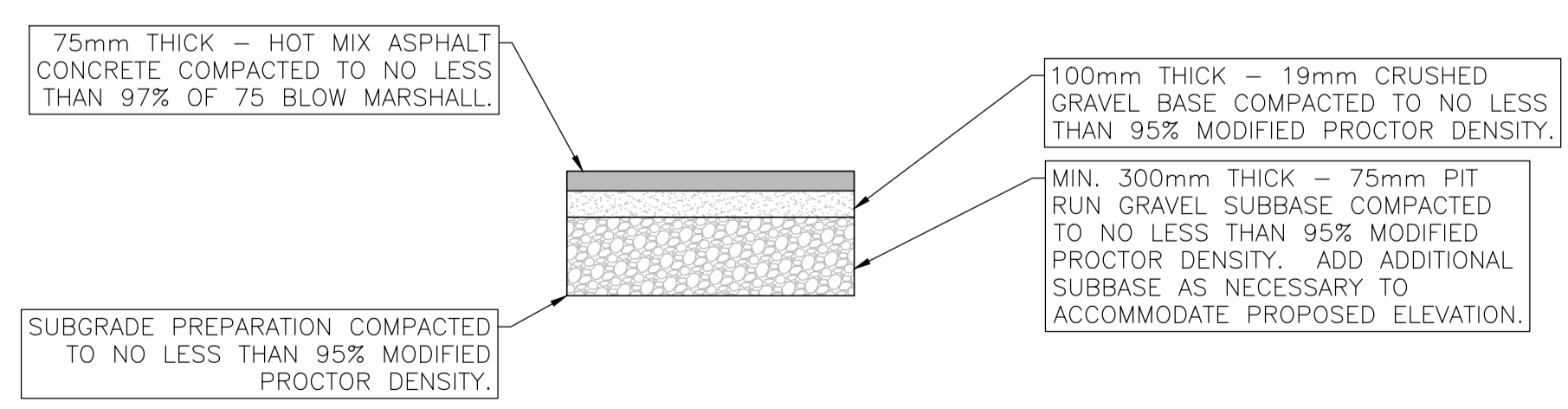

TYPICAL ASPHALT PAVEMENT STRUCTURE
SCALE: NTS

LEGEND	
PR. ASPHALT	
PR. ASPHALT OVER MDS	
EX. ASPHALT	
PR. CONCRETE	
EX. CONCRETE	
PR. GRAVEL	
EX. GRAVEL	
EX. ELECTRICAL	E
EX. GAS	G
EX. DRAINAGE	D
EX. WATER	W
EX. SANITARY	S
EX. FENCE LINE	X
EX. EDGE OF PAVEMENT	
EX. FENCE POST	
EX. EDGE OF BUILDING	
EX. VALVE	
EX. STREET LIGHT	
EX. UTILITY POLE	
EX. SIGN	
PR. ELEVATION	XX.XX
PR. GRADING	X.X%

Revision/	Description/Description	Date/Date
5	ISSUED FOR TENDER	2011/06

Client/client

CORRECTIONAL SERVICE CANADA

Project title/Titre du projet

PACIFIC REGION PERIMETER FENCE UPGRADES

Consultant Signature Only

Designed by/Concept par
S. VERKAIK

Drawn by/Dessiné par
T. ASHBURY

PWGC Project Manager/Administrateur de Projets TPSGC
DARYL SINCLAIR / TONY TANG

Regional Manager, Architectural and Engineering Services
Gestionnaire régionale, Services d'architectural et de génie, TPSGC
PREETIPAL PAUL

Drawing title/Titre du dessin

MISSION INSTITUTION
GATE 12

Project No./No. du projet	Sheet/Feuille	Revision no./La Révision no.
R.071529.001	MI-C301	5

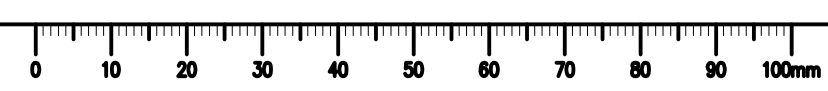

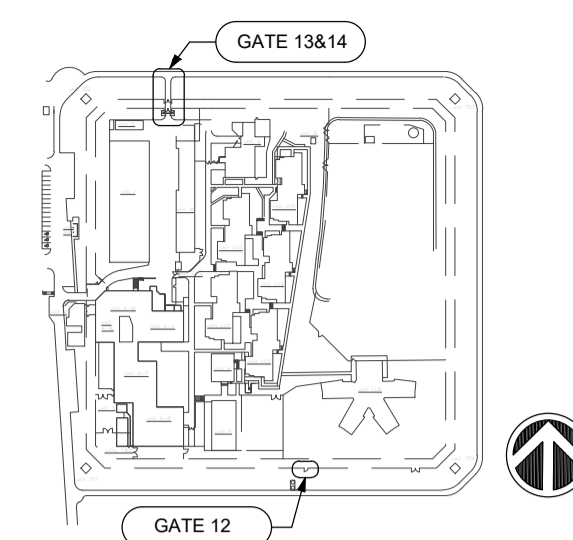
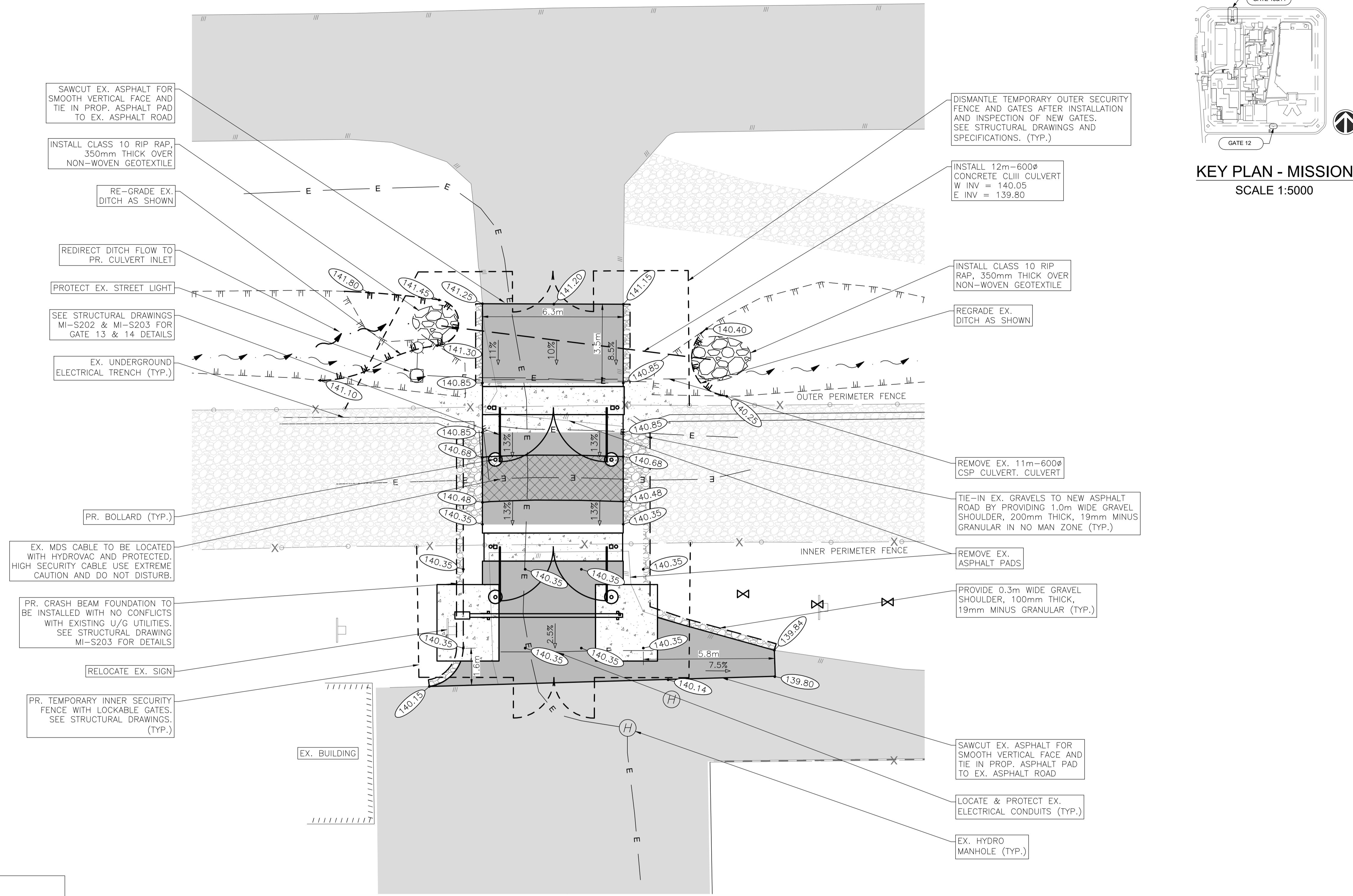
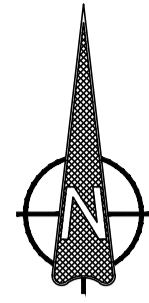

LEGEND	
PR. ASPHALT	
PR. ASPHALT OVER MDS	
EX. ASPHALT	
PR. CONCRETE	
EX. CONCRETE	
PR. GRAVEL	
EX. GRAVEL	
EX. ELECTRICAL	E
EX. GAS	G
EX. DRAINAGE	D
EX. WATER	W
EX. SANITARY	S
EX. FENCE LINE	X
EX. EDGE OF PAVEMENT	
EX. FENCE POST	
EX. VALVE	
EX. STREET LIGHT	
EX. UTILITY POLE	
EX. SIGN	
PR. ELEVATION	XX.XX
PR. GRADING	X.X%

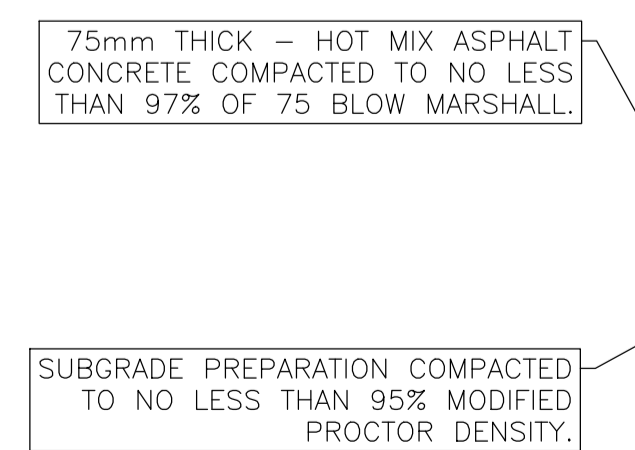

TYPICAL ASPHALT PAVEMENT STRUCTURE
SCALE: NTS

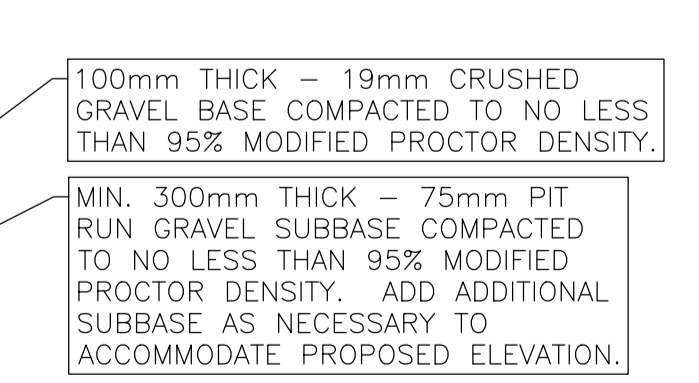

ASPHALT PAVEMENT STRUCTURE OVER MDS CABLE
SCALE: NTS

Revision/	Description/Description	Date/Date
5	ISSUED FOR TENDER	2011/06

Client/client
CORRECTIONAL SERVICE CANADA

Project title/Titre du projet
PACIFIC REGION PERIMETER FENCE UPGRADES

Consultant Signature Only
 Designed by/Concept par
S. VERKAIK

Drawn by/Dessiné par
T. ASHBURY

PWGSC Project Manager/Administrateur de Projets TPSGC
DARYL SINCLAIR / TONY TANG

Regional Manager, Architectural and Engineering Services
 Gestionnaire régionale, Services d'architectural et de génie, TPSGC
PREETIPAL PAUL

Drawing title/Titre du dessin
MISSION INSTITUTION GATE 13 & 14

Project No./No. du projet	Sheet/Feuille	Revision no./La Révision no.
R.071529.001	MI-C302	5



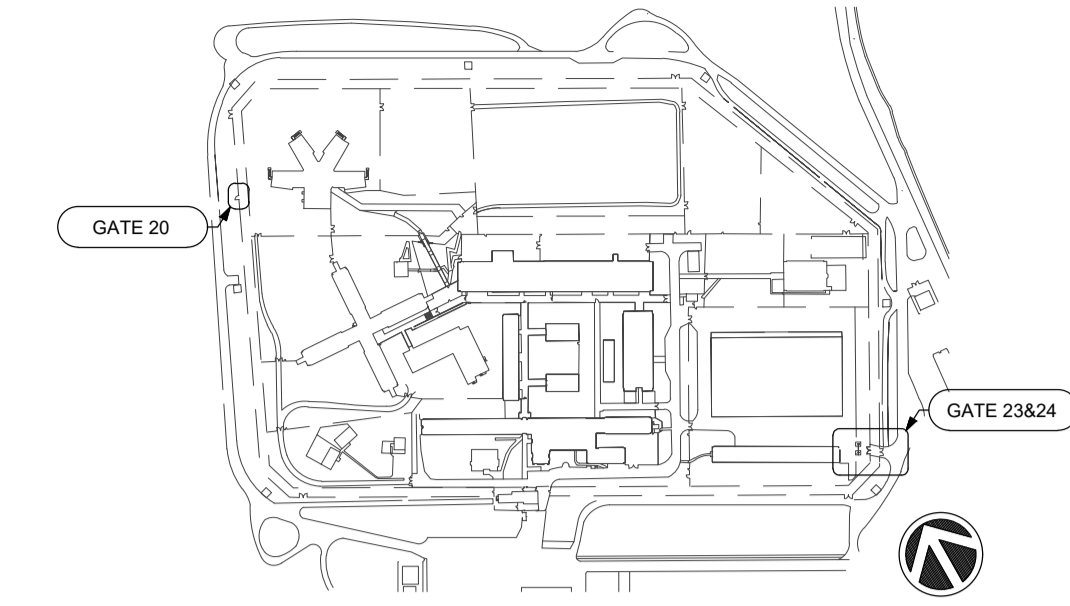
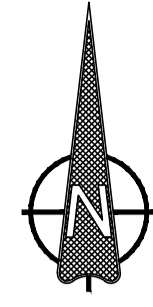

KEY PLAN - MASTQUI
SCALE 1:5000



GATE 20
SCALE 1:100

LEGEND	
PR. ASPHALT	
PR. ASPHALT OVER MDS	
EX. ASPHALT	
PR. CONCRETE	
EX. CONCRETE	
PR. GRAVEL	
EX. GRAVEL	
EX. ELECTRICAL	E
EX. GAS	G
EX. DRAINAGE	D
EX. WATER	W
EX. SANITARY	S
EX. FENCE LINE	X
EX. EDGE OF PAVEMENT	
EX. FENCE POST	
EX. EDGE OF BUILDING	
EX. VALVE	
EX. STREET LIGHT	
EX. UTILITY POLE	
EX. SIGN	
PR. ELEVATION	XX.XX
PR. GRADING	X.X%



Revision/	Description/Description	Date/Date
7	ISSUED FOR TENDER	20/11/06

CORRECTIONAL SERVICE CANADA

Project title/Titre du projet
PACIFIC REGION PERIMETER FENCE UPGRADES

Consultant Signature Only
Designed by/Concept par
S. VERKAIK
Drawn by/Dessiné par
T. ASHBURY
PWGSC Project Manager/Administrateur de Projets TPSGC
DARYL SINCLAIR / TONY TANG
Regional Manager, Architectural and Engineering Services
Gestionnaire régionale, Services d'architectural et de génie, TPSGC
PREETIPAL PAUL
Drawing title/Titre du dessin

MATSQUI INSTITUTION
GATES 20 & 21

Project No./No. du projet R.071529.001	Sheet/Feuille MA-C301	Revision no./La Révision no. 7
--	---------------------------------	--



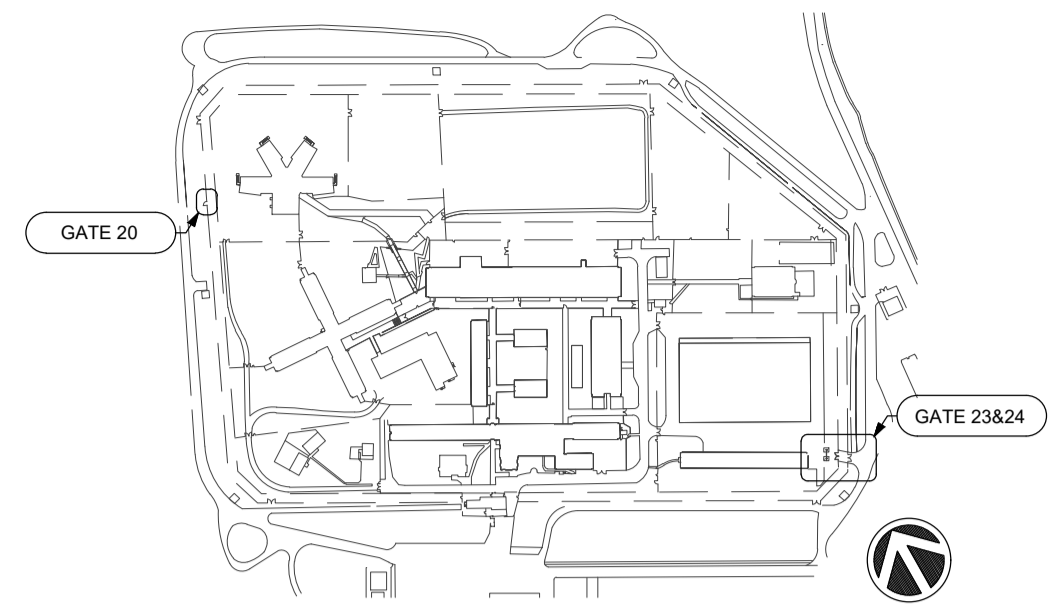

KEY PLAN - MASTQUI
SCALE 1:5000

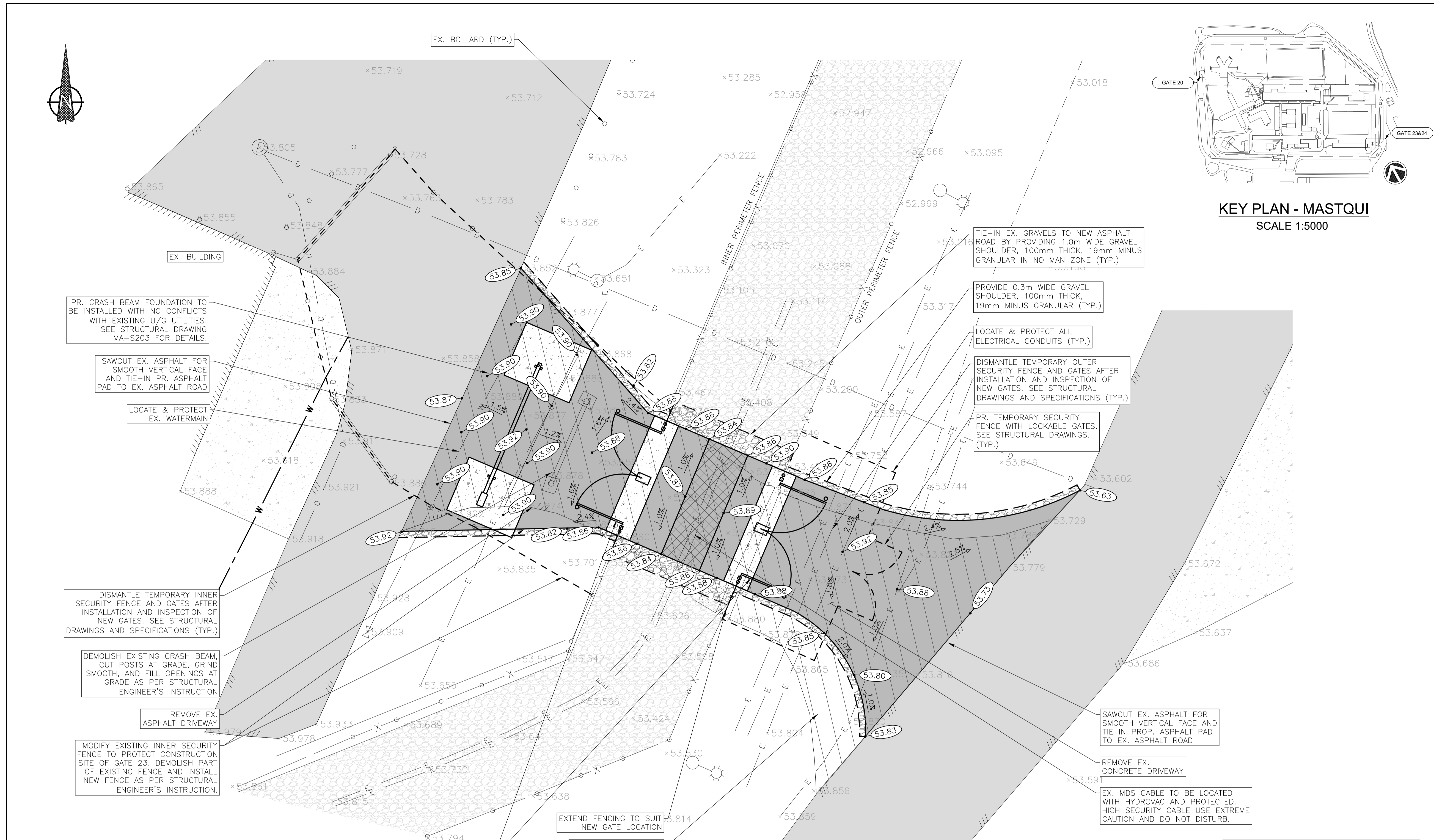

GATES 23 & 24
SCALE 1:100

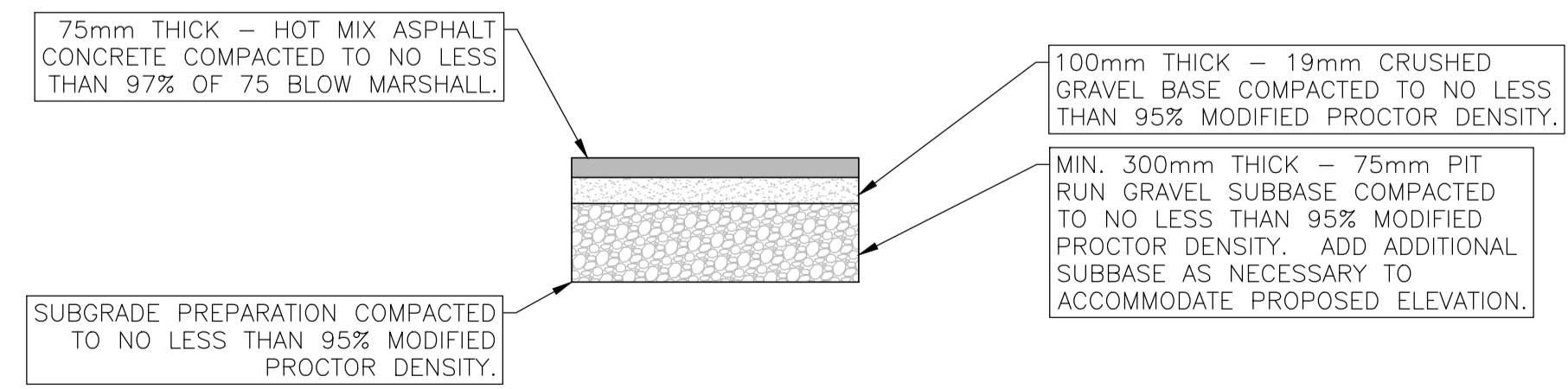

TYPICAL ASPHALT PAVEMENT STRUCTURE
SCALE: NTS

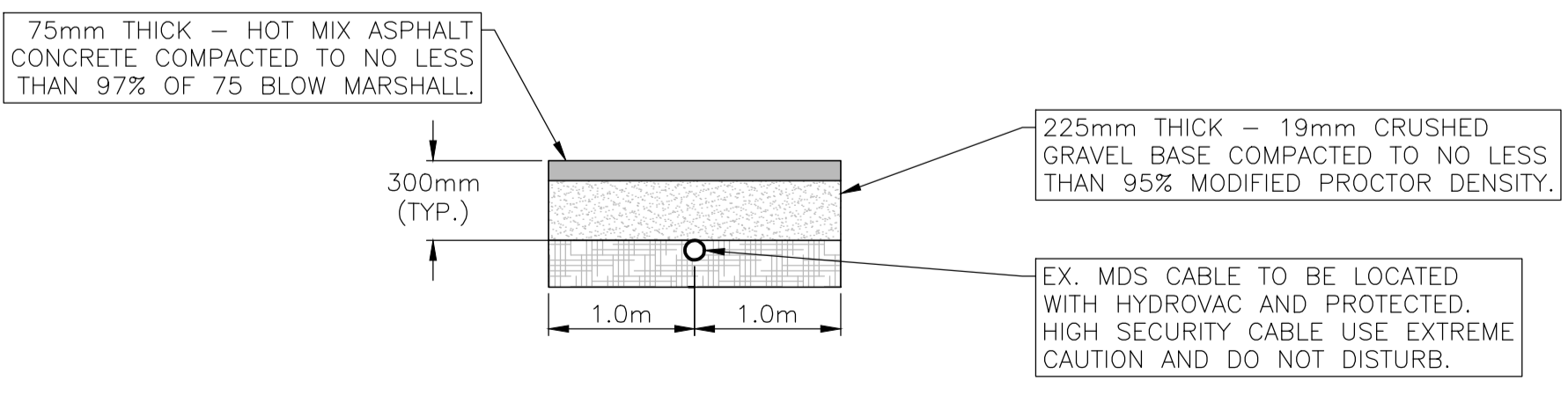

ASPHALT PAVEMENT STRUCTURE OVER MDS CABLE
SCALE: NTS

LEGEND

PR. ASPHALT	[Pattern]
PR. ASPHALT OVER MDS	[Pattern]
EX. ASPHALT	[Pattern]
PR. CONCRETE	[Pattern]
EX. CONCRETE	[Pattern]
PR. GRAVEL	[Pattern]
EX. GRAVEL	[Pattern]
REMOVE EX. ASPHALT	[Pattern]
EX. ELECTRICAL	E
EX. GAS	G
EX. DRAINAGE	D
EX. WATER	W
EX. SANITARY	S
EX. FENCE LINE	X
EX. EDGE OF PAVEMENT	[Symbol]
EX. FENCE POST	[Symbol]
EX. EDGE OF BUILDING	[Symbol]
EX. VALVE	[Symbol]
EX. STREET LIGHT	[Symbol]
EX. UTILITY POLE	[Symbol]
EX. SIGN	[Symbol]
PR. ELEVATION	XX.XX
PR. GRADING	X.XX

8	ISSUED FOR TENDER	20/11/06
Revision/	Description/Description	Date/Date

Client/client
CORRECTIONAL SERVICE CANADA

Project title/Titre du projet
PACIFIC REGION PERIMETER FENCE UPGRADES

Consultant Signature Only
Designed by/Concept par
S. VERKAIK
Drawn by/Dessiné par
T. ASHBURY
PWGSC Project Manager/Administrateur de Projets TPSGC
DARYL SINCLAIR / TONY TANG
Regional Manager, Architectural and Engineering Services
Gestionnaire régionale, Services d'architectural et de génie, TPSGC
PREETIPAL PAUL
Drawing title/Titre du dessin

MATSQUI INSTITUTION
GATES 23 & 24

Project No./No. du projet	Sheet/Feuille	Revision no./La Révision no.
R.071529.001	MA-C302	8

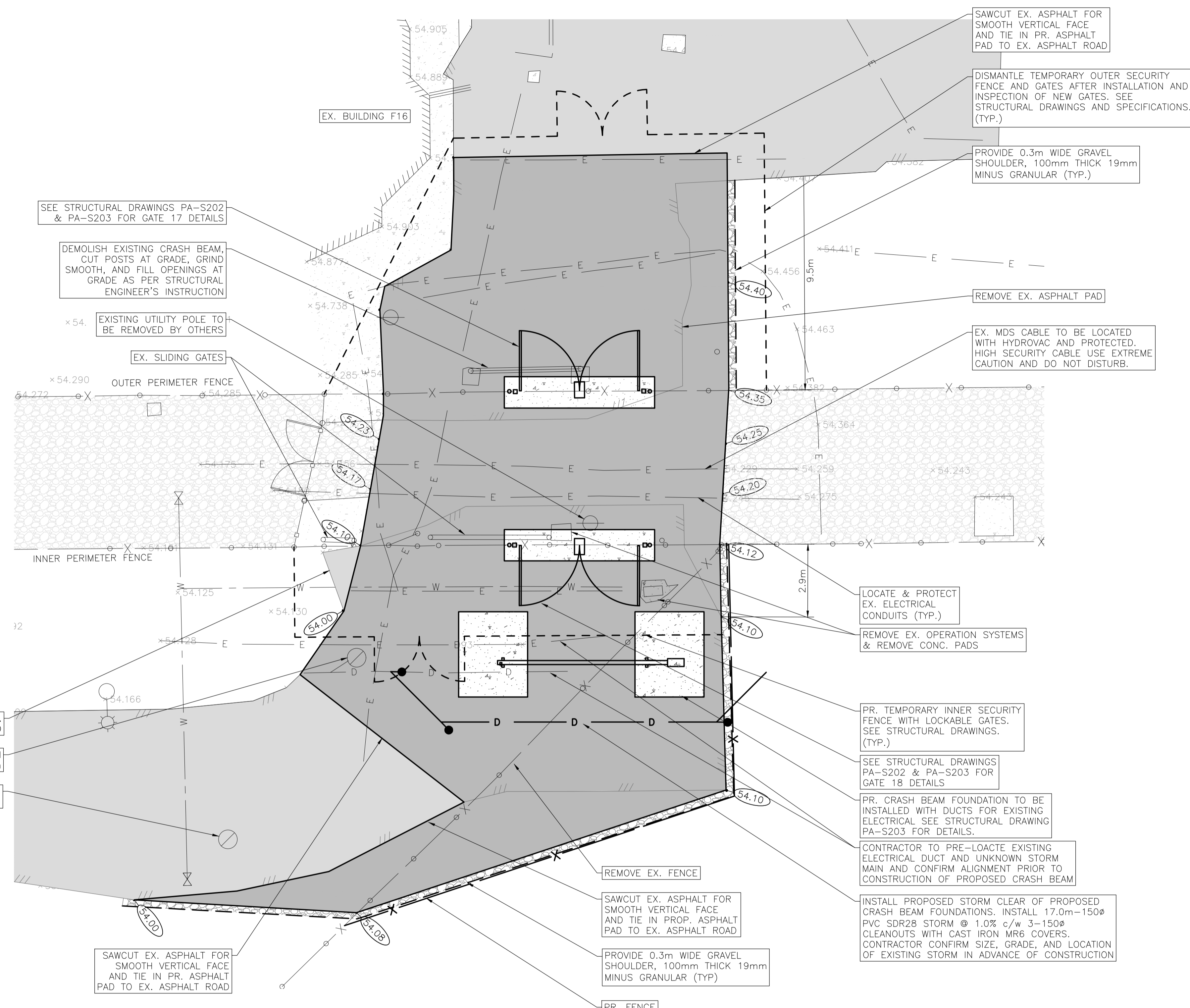
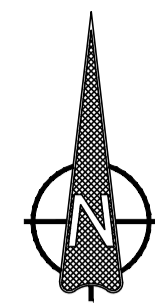

PACIFIC NORTH GATES 17 & 18

SCALE 1:100

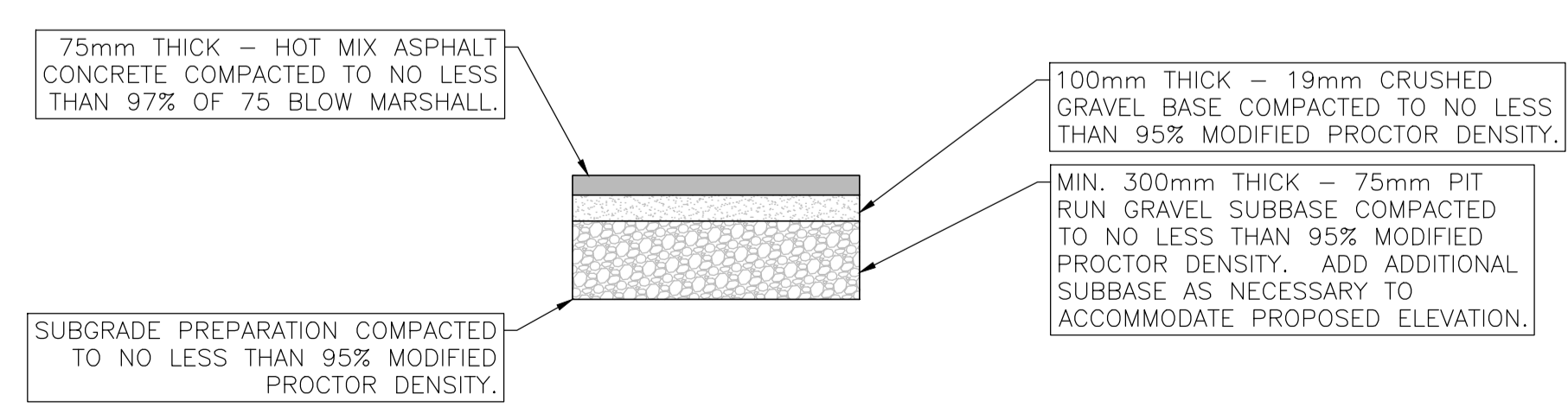

TYPICAL ASPHALT PAVEMENT STRUCTURE

SCALE: NTS

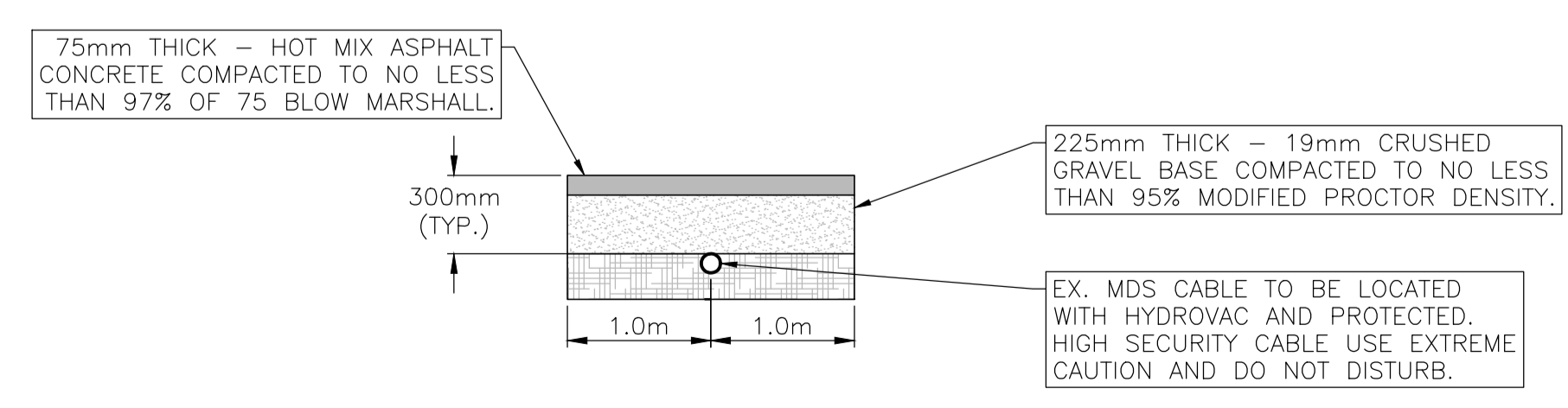

ASPHALT PAVEMENT STRUCTURE OVER MDS CABLE

SCALE: NTS

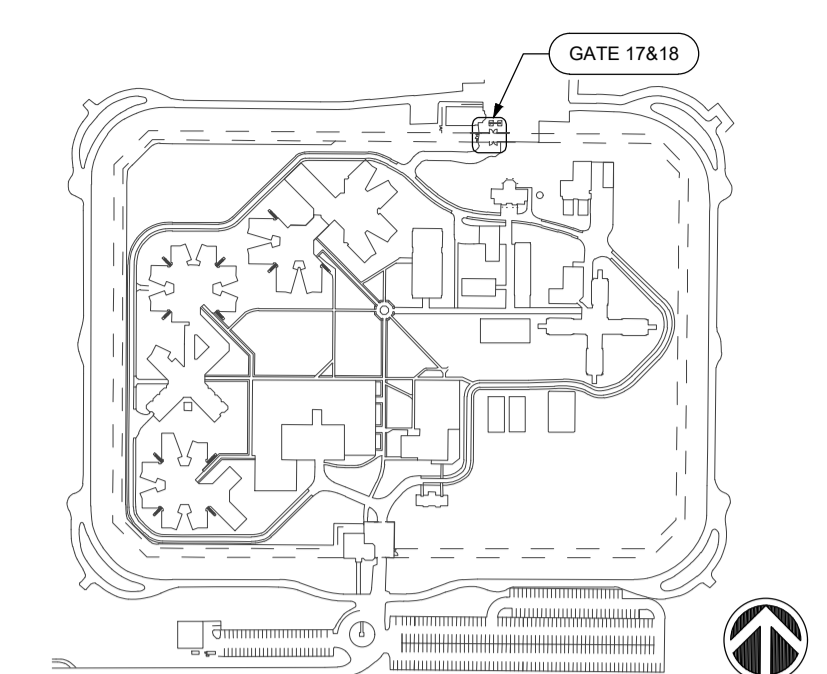

KEY PLAN - PACIFIC
SCALE 1:5000

LEGEND

PR. ASPHALT	
PR. ASPHALT OVER MDS	
EX. ASPHALT	
PR. CONCRETE	
EX. CONCRETE	
PR. GRAVEL	
EX. GRAVEL	
EX. ELECTRICAL	E
EX. GAS	G
EX. DRAINAGE	D
EX. WATER	W
EX. SANITARY	S
EX. FENCE LINE	X
EX. EDGE OF PAVEMENT	
EX. FENCE POST	
EX. EDGE OF BUILDING	
EX. VALVE	
EX. STREET LIGHT	
EX. UTILITY POLE	
EX. SIGN	
PR. ELEVATION	XX.XX
PR. GRADING	X.X%



7	ISSUED FOR TENDER	20/11/06
Revision/	Description/Description	Date/Date

Client/client
CORRECTIONAL SERVICE CANADA

Project title/Titre du projet
PACIFIC REGION PERIMETER FENCE UPGRADES

Consultant Signature Only
Designed by/Concept par
S. VERKAIK
Drawn by/Dessiné par
T. ASHBURY
PWGSC Project Manager/Administrateur de Projets TPSGC
DARYL SINCLAIR / TONY TANG
Regional Manager, Architectural and Engineering Services
Gestionnaire régionale, Services d'architectural et de génie, TPSGC
PREETIPAL PAUL

Drawing title/Titre du dessin
PACIFIC INSTITUTION NORTH GATES 17 & 18

Project No./No. du projet R.071529.001	Sheet/Feuille PA-C301	Revision no./La Révision no. 7
--	---------------------------------	--

