



National Defence

Défense nationale

National Defence Headquarters
Ottawa, Ontario
K1A 0K2

Quartier général de la Défense nationale
Ottawa (Ontario)
K1A 0K2

REQUEST FOR PROPOSAL DEMANDE DE PROPOSITION

RETURN BIDS TO: RETOURNER LES SOUMISSIONS À :

Via e-mail to :

Cristian Ardila Buitrago
Contracting Authority
DLP 4-2-1-1
cristian.ardilabuitrago@forces.gc.ca

Proposal To: National Defence Canada

We hereby offer to sell to Her Majesty the Queen in right of Canada, in accordance with the terms and conditions set out herein, referred to herein or attached hereto, the goods and services listed herein and on any attached sheets at the price(s) set out therefore.

Proposition à : Défense nationale Canada

Nous offrons par la présente de vendre à Sa Majesté la Reine du chef du Canada, aux conditions énoncées ou incluses par référence dans la présente et aux annexes ci-jointes, les biens et services énumérés ici et sur toute feuille ci-annexée, au(x) prix indiqués(s).

Solicitation Closes – L'invitation prend fin

At – à : 14:00 EDT / 14h00 HAE

On - le : 2021-05-14

Title/Titre Leopard 1 Conversion Targets	Solicitation No – N° de l'invitation W8486-217668/B
Date of Solicitation – Date de l'invitation 2021-04-29	
Address Enquiries to – Adresser toutes questions à Cristian Ardila Buitrago Contracting Authority DLP 4-2-1-1 Department of National Defence Assistant Deputy Minister Materiel Director General Land Equipment Program Management 101 Colonel By Drive Ottawa, ON K1A 0K2 E-mail address: cristian.ardilabuitrago@forces.gc.ca	
Telephone No. – N° de téléphone 819-939-3830	FAX No – N° de fax N/A
Destination see herein / voir à l'intérieur	

Instructions: Municipal taxes are not applicable. Unless otherwise specified herein all prices quoted must include all applicable Canadian customs duties, GST/HST, excise taxes and are to be delivered Delivery Duty Paid including all delivery charges to destination(s) as indicated. The amount of the Goods and Services Tax/Harmonized Sales Tax is to be shown as a separate item.

Instructions: Les taxes municipales ne s'appliquent pas. Sauf indication contraire, les prix indiqués doivent comprendre les droits de douane canadiens, la TPS/TVH et la taxe d'accise. Les biens doivent être livrés « rendu droits acquittés », tous frais de livraison compris, à la ou aux destinations indiquées. Le montant de la taxe sur les produits et services/taxe de vente harmonisée doit être indiqué séparément.

Delivery required - Livraison exigée see herein / voir à l'intérieur	Delivery offered - Livraison proposée
Vendor Name and Address - Raison sociale et adresse du fournisseur	
Name and title of person authorized to sign on behalf of vendor (type or print) - Nom et titre de la personne autorisée à signer au nom du fournisseur (caractère d'imprimerie)	
Name/Nom _____	Title/Titre _____
Signature _____	Date _____

TABLE OF CONTENTS

TABLE OF CONTENTS	1
PART 1 - GENERAL INFORMATION	3
1.1 SECURITY REQUIREMENTS	3
1.2 STATEMENT OF WORK.....	3
1.3 DEBRIEFINGS.....	3
1.4 TRADE AGREEMENTS	3
1.5 CANADIAN CONTENT	3
1.6 REISSUE OF BID SOLICITATION.....	3
PART 2 - BIDDER INSTRUCTIONS	4
2.1 STANDARD INSTRUCTIONS, CLAUSES AND CONDITIONS.....	4
2.2 SUBMISSION OF BIDS.....	4
2.3 FORMER PUBLIC SERVANT.....	5
2.4 ENQUIRIES - BID SOLICITATION	6
2.5 APPLICABLE LAWS.....	6
PART 3 - BID PREPARATION INSTRUCTIONS	7
3.1 BID PREPARATION INSTRUCTIONS	7
PART 4 - EVALUATION PROCEDURES AND BASIS OF SELECTION	8
4.1 EVALUATION PROCEDURES	8
4.2 BASIS OF SELECTION	9
PART 5 – CERTIFICATIONS AND ADDITIONAL INFORMATION	11
5.1 CERTIFICATIONS REQUIRED WITH THE BID	11
5.2 CERTIFICATIONS PRECEDENT TO CONTRACT AWARD AND ADDITIONAL INFORMATION.....	11
PART 6 - RESULTING CONTRACT CLAUSES	13
6.1 SECURITY REQUIREMENTS	13
6.2 STATEMENT OF WORK.....	13
6.3 STANDARD CLAUSES AND CONDITIONS.....	13
6.4 TERM OF CONTRACT	13
6.5 AUTHORITIES.....	13
6.6 PROACTIVE DISCLOSURE OF CONTRACTS WITH FORMER PUBLIC SERVANTS.....	15
6.7 PAYMENT.....	15
6.8 INVOICING INSTRUCTIONS	15
6.9 CERTIFICATIONS	15
6.10 APPLICABLE LAWS.....	16
6.11 PRIORITY OF DOCUMENTS	16
6.12 DEFENCE CONTRACT	16
6.13 FOREIGN NATIONALS (CANADIAN CONTRACTOR).....	16
6.14 INSURANCE REQUIREMENTS.....	16
6.15 CONTROLLED GOODS.....	16
6.16 QUALITY ASSURANCE	16
ANNEX A	18
APPENDIX 1 TO ANNEX A,	27
APPENDIX 2 TO ANNEX A,	29

APPENDIX 3 TO ANNEX A,	31
APPENDIX 4 TO ANNEX A,	37
APPENDIX 5 TO ANNEX A	46
APPENDIX 6 TO ANNEX A	52
ANNEX "B"	58
ANNEX "C"	59
ANNEX "D"	60

PART 1 - GENERAL INFORMATION

1.1 Security Requirements

There is no security requirement.

1.2 Statement of Work

The requirement is detailed in Annex "A", Statement of Work.

1.3 Debriefings

Bidders may request a debriefing on the results of the bid solicitation process. Bidders should make the request to the Contracting Authority within 15 working days from receipt of the results of the bid solicitation process. The debriefing may be in writing, by telephone or in person.

1.4 Trade Agreements

The requirement is subject to the provisions of the Canadian Free Trade Agreement (CFTA).

1.5 Canadian Content

The requirement is subject to a preference for Canadian goods and/or services.

1.6 Reissue of Bid Solicitation

This bid solicitation cancels and supersedes previous bid solicitation number W8486-217668/A dated 2021-01-25 with a closing of 2021-03-09 at 14:00 Eastern Standard Time (EST). A debriefing or feedback session will be provided upon request to bidders/offerors/suppliers who bid on the previous solicitation.

PART 2 - BIDDER INSTRUCTIONS

2.1 Standard Instructions, Clauses and Conditions

All instructions, clauses and conditions identified in the bid solicitation by number, date and title are set out in the Standard Acquisition Clauses and Conditions Manual (<https://buyandsell.gc.ca/policy-and-guidelines/standard-acquisition-clauses-and-conditions-manual>) issued by Public Works and Government Services Canada.

Bidders who submit a bid agree to be bound by the instructions, clauses and conditions of the bid solicitation and accept the clauses and conditions of the resulting contract.

The 2003 (2020-05-28) Standard Instructions – Goods and Services – Competitive Requirements, are incorporated by reference into and form part of the bid solicitation, with the following modifications:

- a) Section 02, Procurement Business Number is deleted in its entirety.
- b) Section 20(2), Further Information is deleted in its entirety.
- c) Section 05, Submission of Bids – Subsection 3 is deleted.
- d) Subsection 2.d. of Section 05, Submission of Bids, is deleted in its entirety and replaced with the following:

Send its bid only to the address specified in the bid solicitation.

- e) Section 06, Late Bids, Is deleted in its entirety;
- f) The text under Section 07, Delayed Bids, is deleted in its entirety and replaced with the following:

It is the Bidder's responsibility to ensure that the Contracting Authority has received the entire submission. Misrouting or other electronic delivery issues resulting in late submission of bids will not be accepted.
- g) Subsection 1 of Section 08, Transmission by facsimile or by epost Connect, is deleted in its entirety.
- h) Subsection 5.4 of 2003, Standard Instructions - Goods or Services –Competitive Requirements, is amended as follows:

Delete: 60 days

Insert: 90 days

2.1.1 SACC Manual Clauses

2.1.1.2 SACC Manual clause [A9130T](#) (2014-11-27), Controlled Goods Program

2.2 Submission of Bids

Bids must be submitted only to the Contracting Authority by electronic mail by the date and time indicated on page 1 of the Bid Solicitation. Bids must be received electronically as noted below:

Electronic Submissions: Individual e-mails exceeding five (5) megabytes, or that includes other factors such as embedded macros and/or links, may be rejected by the DND e-mail system and/or firewall(s)

without notice to the Bidder or Contracting Authority. Larger bids may be submitted through more than one email. The Contracting Authority will confirm receipt of documents. It is the Bidder's responsibility to ensure that the Contracting Authority has received the entire submission. Bidders should not assume that all documents have been received unless the Contracting Authority confirms receipt of each document. In order to minimize the potential for technical issues, Bidders are requested to allow sufficient time before the closing time and date to confirm receipt. Technical and financial documents received after the closing time and date will not be accepted.

Due to the nature of the bid solicitation, bids transmitted by facsimile and ePost Connect will not be accepted.

2.3 Former Public Servant

Contracts awarded to former public servants (FPS) in receipt of a pension or of a lump sum payment must bear the closest public scrutiny, and reflect fairness in the spending of public funds. In order to comply with Treasury Board policies and directives on contracts awarded to FPSs, bidders must provide the information required below before contract award. If the answer to the questions and, as applicable the information required have not been received by the time the evaluation of bids is completed, Canada will inform the Bidder of a time frame within which to provide the information. Failure to comply with Canada's request and meet the requirement within the prescribed time frame will render the bid non-responsive.

2.3.1 Definitions

For the purposes of this clause, "former public servant" is any former member of a department as defined in the [Financial Administration Act](#), R.S., 1985, c. F-11, a former member of the Canadian Armed Forces or a former member of the Royal Canadian Mounted Police. A former public servant may be:

- a. an individual;
- b. an individual who has incorporated;
- c. a partnership made of former public servants; or
- d. a sole proprietorship or entity where the affected individual has a controlling or major interest in the entity.

"lump sum payment period" means the period measured in weeks of salary, for which payment has been made to facilitate the transition to retirement or to other employment as a result of the implementation of various programs to reduce the size of the Public Service. The lump sum payment period does not include the period of severance pay, which is measured in a like manner.

"pension" means a pension or annual allowance paid under the [Public Service Superannuation Act](#) (PSSA), R.S., 1985, c. P-36, and any increases paid pursuant to the [Supplementary Retirement Benefits Act](#), R.S., 1985, c. S-24 as it affects the PSSA. It does not include pensions payable pursuant to the [Canadian Forces Superannuation Act](#), R.S., 1985, c. C-17, the [Defence Services Pension Continuation Act](#), 1970, c. D-3, the [Royal Canadian Mounted Police Pension Continuation Act](#), 1970, c. R-10, and the [Royal Canadian Mounted Police Superannuation Act](#), R.S., 1985, c. R-11, the [Members of Parliament Retiring Allowances Act](#), R.S. 1985, c. M-5, and that portion of pension payable to the [Canada Pension Plan Act](#), R.S., 1985, c. C-8.

2.3.2 Former Public Servant in Receipt of a Pension

As per the above definitions, is the Bidder a FPS in receipt of a pension? **Yes** () **No** ()

If so, the Bidder must provide the following information, for all FPSs in receipt of a pension, as applicable:

- a. name of former public servant;
- b. date of termination of employment or retirement from the Public Service.

By providing this information, Bidders agree that the successful Bidder's status, with respect to being a former public servant in receipt of a pension, will be reported on departmental websites as part of the published proactive disclosure reports in accordance with [Contracting Policy Notice: 2012-2](#) and the [Guidelines on the Proactive Disclosure of Contracts](#).

2.3.3 Work Force Adjustment Directive

Is the Bidder a FPS who received a lump sum payment pursuant to the terms of the Work Force Adjustment Directive? **Yes** () **No** ()

If so, the Bidder must provide the following information:

- a. name of former public servant;
- b. conditions of the lump sum payment incentive;
- c. date of termination of employment;
- d. amount of lump sum payment;
- e. rate of pay on which lump sum payment is based;
- f. period of lump sum payment including start date, end date and number of weeks;
- g. number and amount (professional fees) of other contracts subject to the restrictions of a work force adjustment program.

For all contracts awarded during the lump sum payment period, the total amount of fees that may be paid to a FPS who received a lump sum payment is \$5,000, including Applicable Taxes.

2.4 Enquiries - Bid Solicitation

All enquiries must be submitted in writing to the Contracting Authority no later than five (5) calendar days before the bid closing date. Enquiries received after that time may not be answered.

Bidders should reference as accurately as possible the numbered item of the bid solicitation to which the enquiry relates. Care should be taken by Bidders to explain each question in sufficient detail in order to enable Canada to provide an accurate answer. Technical enquiries that are of a proprietary nature must be clearly marked "proprietary" at each relevant item. Items identified as "proprietary" will be treated as such except where Canada determines that the enquiry is not of a proprietary nature. Canada may edit the question(s) or may request that the Bidder do so, so that the proprietary nature of the question(s) is eliminated, and the enquiry can be answered to all Bidders. Enquiries not submitted in a form that can be distributed to all Bidders may not be answered by Canada.

2.5 Applicable Laws

Any resulting contract must be interpreted and governed, and the relations between the parties determined, by the laws in force in Ontario.

Bidders may, at their discretion, substitute the applicable laws of a Canadian province or territory of their choice without affecting the validity of their bid, by deleting the name of the Canadian province or territory specified and inserting the name of the Canadian province or territory of their choice. If no change is made, it acknowledges that the applicable laws specified are acceptable to the Bidders.

PART 3 - BID PREPARATION INSTRUCTIONS

3.1 Bid Preparation Instructions

Canada requests that Bidders provide their bid in separate sections as follows:

Section I: Technical Bid (1 electronic copy)

Section II: Financial Bid (1 electronic copy)

Section III: Certifications (1 electronic copy)

Prices must appear in the financial bid only. No prices must be indicated in any other section of the bid.

Canada requests that Bidders follow the format instructions described below in the preparation of their bid:

- (a) use 8.5 x 11 inch (216 mm x 279 mm) format;
- (b) use a numbering system that corresponds to the bid solicitation.

Section I: Technical Bid

In their technical bid, Bidders should demonstrate their understanding of the requirements contained in the bid solicitation and explain how they will meet these requirements. Bidders should demonstrate their capability and describe their approach in a thorough, concise and clear manner for carrying out the work.

The technical bid should address clearly and in sufficient depth the points that are subject to the evaluation criteria against which the bid will be evaluated. Simply repeating the statement contained in the bid solicitation is not sufficient. In order to facilitate the evaluation of the bid, Canada requests that Bidders address and present topics in the order of the evaluation criteria under the same headings. To avoid duplication, Bidders may refer to different sections of their bids by identifying the specific paragraph and page number where the subject topic has already been addressed.

Section II: Financial Bid

Bidders must submit their financial bid as follows:

Bidders must submit firm prices, Delivered Duty Paid (DDP) at 4 Wing Cold Lake, Incoterms 2010, Applicable Taxes excluded. The total amount of Applicable Taxes must be shown separately. The bidders firm price will include any and all costs associated with the movement of the vehicles as required in Annex A.

Unless the bid solicitation specifically requires bids to be submitted in Canadian currency, bids submitted in foreign currency will be converted to Canadian currency for evaluation purposes. The rate given by the Bank of Canada in effect on the bid solicitation closing date, or on another date specified in the bid solicitation, will be applied as a conversion factor to the bids submitted in foreign currency.

3.1.1 Electronic Payment of Invoices – Bid

If you are willing to accept payment of invoices by Electronic Payment Instruments, complete Annex "C" Electronic Payment Instruments, to identify which ones are accepted.

If Annex "C" Electronic Payment Instruments is not completed, it will be considered as if Electronic Payment Instruments are not being accepted for payment of invoices.

Acceptance of Electronic Payment Instruments will not be considered as an evaluation criterion.

3.1.2 Exchange Rate Fluctuation

C3011T (2013-11-06), Exchange Rate Fluctuation

3.1.3 SACC Manual Clauses

Section III: Certifications

Bidders must submit the certifications and additional information required under Part 5.

PART 4 - EVALUATION PROCEDURES AND BASIS OF SELECTION

4.1 Evaluation Procedures

- (a) Bids will be assessed in accordance with the entire requirement of the bid solicitation including the technical and financial evaluation criteria.
- (b) An evaluation team composed of representatives of Canada will evaluate the bids.
- (c) A3070T (2020-07-30), Evaluation Procedures for Procurement Conditionally Limited to Canadian Content

4.1.1 Technical Evaluation

4.1.1.1 Mandatory Technical Criteria

Bidders will technically assessed based on the following mandatory criteria:

Criteria	Evaluation Criteria	Requirement
M0	The Contractor must provide a detailed program management plan, work breakdown structure, and schedule that describes their understanding of the SOW. This must include their proposed approach for conducting the required work and a demonstration on how similar work was completed on previous projects. While the documents will be revised, if the bidder is awarded the contract, these documents must be submitted with the technical bid in order for the bidder to be further assessed in this process.	The Contractor must provide a draft version of the Data Items Deliverables (DIDs) as noted in Annex A Section 4.2
M1	The bidder must certify that they have an area with a lockable barrier enclosure of at least 6 feet high and under 24 hour surveillance. The surveillance can be electronic or physical. The minimum dimensions of the secure area must enclose a minimum of 4 vehicles. The vehicle footprint can be found at Annex A, Para 2, Sub-para 2.1.1	Bidders must provide a separate letter on company letterhead certifying that the secure area is as noted in Annex A para 4.5.1 and be signed by an officer of the company or they simply insert a state in their bid.
M2	The bidder must certify that the hazardous materials including the PCBs & Asbestos are removed and disposed in accordance with the applicable municipal and federal regulations.	Bidders must provide a separate letter on company letterhead certifying that all hazardous materials, including PCBs & Asbestos are removed and disposed of in accordance

		with any and all applicable municipal and federal regulations.
M3	The bidder must provide documented proof of being certified by the Canadian Welding Bureau (CWB) or proof that the hired Welder is certified by the CWB.	Certificate or applicable documentation from CWB.
M4	The bidder's must certify that the facility where the work will be performed is located within a 500 kilometers radius from the Edmonton Military base.	The bid must specify the address where the work is to be performed.
M5	The bidder must certify that they access to the special tools and equipment required to perform: the 1) movement, 2) un-loading, 3) loading, 4) towing the vehicle and 5) lifting the turret, at their facility.	Bidders must provide a separate letter on company letterhead certifying they access to the special tools and equipment required to perform: the 1) movement, 2) un-loading, 3) loading, 4) towing the vehicle and 5) lifting the turret, at their facility.
M6	The bidder must certify that they have access to special PPE and/or ventilation system required for the stripping and manipulation of CARC paint at their facility.	Bidders must provide a separate letter on company letterhead certifying that they have access to special PPE and/or ventilation system required for the stripping and manipulation of CARC paint at their facility.
M7	The bidder must provide documented proof of being certified ISO 9001:2015 Or the Contractor's quality management system must address all requirements appropriate to the scope of the Work. Only exclusions in accordance with clause 1.2 of ISO 9001 are acceptable.	Certificate or applicable documentation to demonstrate ISO 90001:2015 requirements are satisfied.

4.1.2 Financial Evaluation

The price of the bid will be evaluated in Canadian dollars, Delivered Duty Paid (DDP) at the destination identified in Section 4.1.12 of the Statement of Work, Incoterms 2010, Canadian customs duties and excise taxes included, Applicable Taxes excluded.

4.2 Basis of Selection

A bid must comply with the requirements of the bid solicitation and meet all mandatory technical evaluation criteria to be declared responsive. The responsive bid with the lowest evaluated price will be recommended for award of a contract.

The lowest evaluated price will be determined as the sum of:

- 1) The Unit Price of the item number 1 of the Annex "B" multiplied by 22;

- 2) The Unit Price of the item number 2 of the Annex "B" multiplied by 21; and,
- 3) The Unit Price of the item number 3 of the Annex "B" multiplied by 6.

PART 5 – CERTIFICATIONS AND ADDITIONAL INFORMATION

Bidders must provide the required certifications and additional information to be awarded a contract.

The certifications provided by Bidders to Canada are subject to verification by Canada at all times. Unless otherwise specified, Canada will declare a bid non-responsive, or will declare a contractor in default if any certification made by the Bidder is found to be untrue whether made knowingly or unknowingly, during the bid evaluation period or during the contract period.

The Contracting Authority will have the right to ask for additional information to verify the Bidder's certifications. Failure to comply and to cooperate with any request or requirement imposed by the Contracting Authority will render the bid non-responsive or constitute a default under the Contract.

5.1 Certifications Required with the Bid

Bidders must submit the following duly completed certifications as part of their bid.

5.1.1 Canadian Content Certification

This procurement is conditionally limited to Canadian services.

Subject to the evaluation procedures contained in the bid solicitation, bidders acknowledge that only bids with a certification that the service offered is a Canadian service, as defined in clause A3050T, may be considered.

Failure to provide this certification completed with the bid will result in the service offered being treated as a non-Canadian service.

The Bidder certifies that:

() the service offered is a Canadian service as defined in paragraph 2 of clause A3050T.

5.2 Certifications Precedent to Contract Award and Additional Information

The certifications and additional information listed below should be submitted with the bid, but may be submitted afterwards. If any of these required certifications or additional information is not completed and submitted as requested, the Contracting Authority will inform the Bidder of a time frame within which to provide the information. Failure to provide the certifications or the additional information listed below within the time frame provided will render the bid non-responsive.

5.2.1 Integrity Provisions – Required Documentation

In accordance with the *[Ineligibility and Suspension Policy](http://www.tpsgc-pwgsc.gc.ca/ci-if/politique-policy-eng.html)* (<http://www.tpsgc-pwgsc.gc.ca/ci-if/politique-policy-eng.html>), the Bidder must provide the required documentation, as applicable, to be given further consideration in the procurement process.

5.2.2 Federal Contractors Program for Employment Equity - Bid Certification

By submitting a bid, the Bidder certifies that the Bidder, and any of the Bidder's members if the Bidder is a Joint Venture, is not named on the Federal Contractors Program (FCP) for employment equity "FCP Limited Eligibility to Bid" list available at the bottom of the page of the [Employment and Social](#)

[Development Canada \(ESDC\) - Labour's website](http://www.esdc.gc.ca/en/jobs/workplace/human_rights/employment_equity/federal_contractor_program.page?&_ga=1.229006812.1158694905.1413548969#afed)
(http://www.esdc.gc.ca/en/jobs/workplace/human_rights/employment_equity/federal_contractor_program.page?&_ga=1.229006812.1158694905.1413548969#afed).

Canada will have the right to declare a bid non-responsive if the Bidder, or any member of the Bidder if the Bidder is a Joint Venture, appears on the "FCP Limited Eligibility to Bid" list at the time of contract award.

Canada will also have the right to terminate the Contract for default if a Contractor, or any member of the Contractor if the Contractor is a Joint Venture, appears on the "[FCP Limited Eligibility to Bid](#)" list during the period of the Contract.

The Bidder must provide the Contracting Authority with a completed annex D [Federal Contractors Program for Employment Equity - Certification](#), before contract award. If the Bidder is a Joint Venture, the Bidder must provide the Contracting Authority with a completed annex Federal Contractors Program for Employment Equity - Certification, for each member of the Joint Venture.

PART 6 - RESULTING CONTRACT CLAUSES

The following clauses and conditions apply to and form part of any contract resulting from the bid solicitation.

6.1 Security Requirements

6.1.1 There is no security requirement applicable to this Contract.

6.2 Statement of Work

The Contractor must perform the Work in accordance with the Statement of Work at Annex "A".

6.3 Standard Clauses and Conditions

All clauses and conditions identified in the Contract by number, date and title are set out in the [Standard Acquisition Clauses and Conditions Manual](https://buyandsell.gc.ca/policy-and-guidelines/standard-acquisition-clauses-and-conditions-manual) (https://buyandsell.gc.ca/policy-and-guidelines/standard-acquisition-clauses-and-conditions-manual) issued by Public Works and Government Services Canada.

6.3.1 General Conditions

2035 (2016-04-04), General Conditions - Higher Complexity - Services, apply to and form part of the Contract, with the following modifications:

a. Definition of Minister is modified as follows:

"Canada", "Crown", "Her Majesty" or "the Government" means Her Majesty the Queen in right of Canada as represented by the Minister of National Defence and any other person duly authorized to act on behalf of that minister or, if applicable, an appropriate minister to whom the Minister of National Defence has delegated his or her powers, duties or functions and any other person duly authorized to act on behalf of that minister.

6.4 Term of Contract

6.4.1 Period of the Contract

The period of the Contract is from date of Contract to _____ (to be completed at contract award).

6.4.4 Shipping Instructions

Services will be delivered at the location specified in the Annex A, Statement of Work.

6.5 Authorities

6.5.1 Contracting Authority

The Contracting Authority for the Contract is:

Name: Cristian Ardila Buitrago
Title: Procurement Officer
Department of National Defence
Directorate General Land Equipment Program Management
Directorate Land Procurement
Adresse: 101 Colonel By Dr.,
Ottawa (ON), K1A 0K2

Attention: DLP 4-2-1-1
Telephone: 819-939-3830
E-mail address: Cristian.ardilabuitrago@forces.gc.ca

The Contracting Authority is responsible for the management of the Contract and any changes to the Contract must be authorized in writing by the Contracting Authority. The Contractor must not perform work in excess of or outside the scope of the Contract based on verbal or written requests or instructions from anybody other than the Contracting Authority.

6.5.2 Technical Authority

The Technical Authority for the Contract is:

Name: _____
Title: _____
Organization: _____
Address: _____
Telephone: ____ - ____ - ____
Facsimile: ____ - ____ - ____
E-mail: _____.

The Technical Authority named above is the representative of the department or agency for whom the Work is being carried out under the Contract and is responsible for all matters concerning the technical content of the Work under the Contract. Technical matters may be discussed with the Technical Authority, however the Technical Authority has no authority to authorize changes to the scope of the Work. Changes to the scope of the Work can only be made through a contract amendment issued by the Contracting Authority.

Quality Assurance Authority

The National Defence Quality Assurance Authority is:

DQA - Directorate of Quality Assurance
Att: DQA 4-3 - Mr. Claude Trepanier
National Defence Headquarters
Mgen George R. Pearkes Building
101 Colonel By Drive
Ottawa, ON K1A 0K2
Tel: (819)-939-0176 or IP Tel: (819) 939-8614
Fax: (819) 939-0381 or IP Fax: (819) 939-8625
E-mail: claudetrepanier@forces.gc.ca

DQA is the Quality Assurance Authority of the Department of National Defence for whom the work is being carried out under this Contract. DQA is responsible to monitor the Supplier's Quality Management System to provide confidence that the Supplier has the ability to fulfill the quality requirements in the contract.

DQA Authority may be represented on-site by a designated Government of Canada, Quality Assurance Representative (QAR) who may be assigned in support of the Technical Authority.

6.5.3 Contractor's Representative

General Enquiries:

Name: _____
Telephone Number: _____
Facsimile Number: _____
E-mail Address: _____

6.6 Proactive Disclosure of Contracts with Former Public Servants

By providing information on its status, with respect to being a former public servant in receipt of a [Public Service Superannuation Act](#) (PSSA) pension, the Contractor has agreed that this information will be reported on departmental websites as part of the published proactive disclosure reports, in accordance with [Contracting Policy Notice: 2012-2](#) of the Treasury Board Secretariat of Canada

6.7 Payment

6.7.1 Basis of Payment

In consideration of the Contractor satisfactorily completing all of its obligations under the Contract, the Contractor will be paid firm unit prices as specified in Annex "B" for a cost of \$ _____. Customs duties are included and Applicable Taxes are extra.

Canada will not pay the Contractor for any design changes, modifications or interpretations of the Work, unless they have been approved, in writing, by the Contracting Authority before their incorporation into the Work.

6.7.2 SAAC Manual Clauses

C2000C (2007-11-30), Taxes – Foreign-based Contractor

6.7.5 Electronic Payment of Invoices – Contract

The Contractor accepts to be paid using any of the following Electronic Payment Instrument(s):

- a. Direct Deposit (Domestic and International);
- b. Electronic Data Interchange (EDI);
- c. Wire Transfer (International Only);

6.8 Invoicing Instructions

The Contractor must submit invoices in accordance with the section entitled "Invoice Submission" of the general conditions. Invoices cannot be submitted until all work identified in the invoice is completed.

Invoices must be distributed as follows:

- a. The original and one (1) copy must be forwarded to the address shown on page 1 of the Contract for certification and payment.

6.9 Certifications

6.9.1 Compliance

Unless specified otherwise, the continuous compliance with the certifications provided by the Contractor in its bid or precedent to contract award, and the ongoing cooperation in providing additional information are conditions of the Contract and failure to comply will constitute the Contractor in default. Certifications are subject to verification by Canada during the entire period of the Contract.

6.9.2 Federal Contractors Program for Employment Equity - Default by the Contractor

The Contractor understands and agrees that, when an Agreement to Implement Employment Equity (AIEE) exists between the Contractor and Employment and Social Development Canada (ESDC)-Labour, the AIEE must remain valid during the entire period of the Contract. If the AIEE becomes invalid, the

name of the Contractor will be added to the "[FCP Limited Eligibility to Bid](#)" list. The imposition of such a sanction by ESDC will constitute the Contractor in default as per the terms of the Contract.

6.10 Applicable Laws

The Contract must be interpreted and governed, and the relations between the parties determined, by the laws in force in _____.

6.11 Priority of Documents

If there is a discrepancy between the wordings of any documents that appear on the list, the wording of the document that first appears on the list has priority over the wording of any document that subsequently appears on the list.

- (a) the Articles of Agreement;
- (b) the general conditions [2035](#) (2016-04-04), General Conditions - Higher Complexity - Services
- (c) Annex A, Statement of Work;
- (d) Annex B, Basis of Payment;
- (e) Annex C, Electronic Payment Instruments;
- (f) Annex D, Federal Contractors Program for Employment Equity - Certification
- (g) the Contractor's bid dated _____,

6.12 Defence Contract

SACC Manual clause [A9006C](#) (2012-07-16) Defence Contract

6.13 Foreign Nationals (Canadian Contractor)

SACC Manual clause [A2000C](#) (2006-06-16), Foreign Nationals (Canadian Contractor)

OR

SACC Manual Clause [A2001C](#) (2006-06-16), Foreign Nationals (Foreign Contractor)

6.14 Insurance Requirements

SACC Manual clause [G1005C](#) (2016-01-28), Insurance - No Specific Requirement

6.15 Controlled Goods

SACC Manual clause [A9131C](#) (2014-11-27), Controlled Goods Program

SACC Manual clause [B4060C](#) (2011-05-16), Controlled Goods

6.16 Quality Assurance

SACC Manual clause [D5540C](#) (2019-05-30), ISO 9001:2015 – Quality Management Systems Requirement (Quality Assurance Code Q)

SACC Manual clause [D5510C](#) (2017-08-17), Quality Assurance Authority (Department of National Defence) Canadian Based Contractor

OR

SACC Manual clause [D5515C](#) (2010-01-11), Quality Assurance Authority (Department of National Defence) – Foreign-based and Unites States Contractor

SACC Manual clause [D5606C](#) (2017-11-28), Release Documents (Department of National Defence) – Canadian Based States based Contractor

OR

SACC Manual clause [D5605C](#) (2010-01-11), Release Documents (Department of National Defence) – United States-based Contractor

OR

SACC Manual clause [D5604C](#) (2008-12-12), Release Documents (Department of National Defence) – Foreign-based Contractor

6.17 Release Documents - Distribution

The Contractor must prepare the release documents in a current electronic format and distribute them as follows:

- a. One (1) copy mailed to consignee marked: "Attention: Receipts Officer";
- b. Two (2) copies with shipment (in a waterproof envelope) to the consignee;
- c. One (1) copy to the Contracting Authority;
- d. One (1) copy to:

*National Defence Headquarters
Mgen George R. Pearkes Building
101 Colonel By Drive
Ottawa, ON K1A 0K2
Attention: DLP 4-2-6*

- e. One (1) copy to the Quality Assurance Representative;
- f. One (1) copy to the Contractor; and
- g. For all non-Canadian contractors, one (1) copy to:

*DQA/Contract Administration
National Defence Headquarters
Mgen George R. Pearkes Building
101 Colonel By Drive
Ottawa, ON K1A 0K2*

E-mail: ContractAdmin.DQA@forces.gc.ca.

ANNEX A

STATEMENT OF WORK (SOW)

LEOPARD 1C2 TANK CONVERSION TO TARGET

Requisition Number:
DND Document # 12350-130-18(DASPM 4)

Date: 15-09-2020
RDIMS# 5548596

Prepared by:

LCMM Leopard 1 FoV
National Defence Headquarters
Major General George R. Pearkes Building
Ottawa, Ontario
K1A 0K2

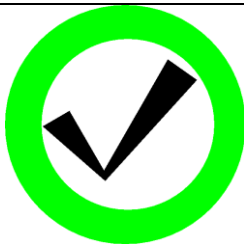

NOTICE

This documentation has been reviewed by the Technical Authority and does not contain controlled goods.

AVIS

Cette documentation a été révisée par l'Autorité technique et ne contient pas de marchandises contrôlées.

1. SCOPE

The purpose of this document is to provide the general and specific requirements for the conversion to be performed to transform the Leopard 1C2 Main Battle Tank (MBT), assemblies and sub-assemblies into an environmentally safe range target. The Contractor will pick-up, prepare, manufacture, convert, dispose/destroy of equipment and deliver up to 49 Leopard 1C2 MBT range targets to Canadian Forces Base (CFB) Cold Lake Air Weapons Range (CLAWR), Alberta.

1.1. Background

In 1978, Canada acquired the Leopard 1 MBT fleet. In 2015 The Army Commander and Vice Chief of Defence Staff (VCDS) approved the disposal of the Leopard 1 Family of Vehicles (FoV). The Army Commander and Vice Chief of Defence Staff (VCDS) approved the conversion of up to 49 Leopard 1C2

MBTs into range targets. 22 of the Leopard 1C2 MBTs are presently stowed at 7 Canadian Forces Supply Depot (CFSD) Edmonton, Alberta and 27 Leopard 1C2 MBTs are stowed at Army Equipment Fielding Centre (AEFC) Montreal, Québec.

1.2. Terminology

Abbreviation

ACM	Asbestos Containing Material
AFES	Automatic Fire Extinguishing System
BMT	Bromotrifluoromethane
CAF	Canadian Armed Force
CARC	Chemical Agent Resisting Coating
CFB	Canadian Forces Base
CFSD	Canadian Forces Supply Depot
CFTO	Canadian Forces Technical Order
CGP	Controlled Goods Program
CLAWR	Cold Lake Air Weapons Range
CPA	Custodian Project Authority
CTAT	Controlled Technology Access and Transfer
DAOD	Defence Administrative Orders and Directives
DMC	Demilitarization Code
DND	Department of National Defence
EA	Environmental Assessment
EHS	Environmental Health and Safety
EMT	Equipment Management Team
FES	Fire Extinguishing System
FoV	Family of Vehicles
GWP	Global Warming Potential
IAW	In Accordance With
MBT	Main Battle Tank
NBC	Nuclear, Biological, Chemical
NPIR	National Pollutant Release Inventory
NSN	Nato Stock Number
N2	Nitrogen Gas
ODP	Ozone Depleting Potential
ODS	Ozone Depleting Substances
PCB	Polychlorinated Biphenyls
PPE	Personal Protective Equipment

RCAF	Royal Canadian Air Forces
SOW	Statement of Work
TA	Technical Authority
VCDS	Vice Chief Defence Staff
WPN	Weapon

2. APPLICABLE DOCUMENTS

2.1. The Contractor must notify the Technical Authority (TA) of any discrepancies discovered between the referenced documents, this SOW, and the equipment undergoing preparation and conversion. The following are the applicable documents for this SOW. In the event of a conflict between the text of this document and the referenced applicable documents listed, this SOW will take precedence over the referenced applicable documents. DND will provide an e-copy of the following document upon request:

2.1.1. C-30-731-000/MA-001 Data summary tank leopard 1;

2.1.2. C-71-345-000/MA-001 data summary - turret, leopard C2 tank;

2.1.3. Environmental Assessments (EA) for Leopard 1 MBT 2184-01267-02 VOL 0002 (DLEPS 6/DGLEPM – 2843) 31 Jul 2014;

2.1.4. C-01-008-000/MD-000 Generic Demilitarization Process – For Controlled Goods Recorded with a Demilitarization Code (DMC) of 'B' or 'D';

2.1.5. D-LM-008-036/SF-000 – Canadian Forces Packaging Specification.

2.1.6. A-LM-184-001/JS-001 Special Instructions for repair and overhaul for contractors.

3. REGULATIONS AND POLICIES

3.1. C-04-005-054/AG-001, Technical Management Policy and Procedures, Land Maintenance System Guidelines for the use of Chemical Agent Resistant Coating (CARC), 1997-05-12;

3.2. Canadian Environmental Protection Act, 1999, c.33 and associated regulations;

3.3. Canada Labour Code Part II and associated Canada Occupational Health and Safety Regulations (SOR/86-304);

3.4. Hazardous Products Act and associated regulations;

3.5. List of Toxic Substances, CEPA 1999, Schedule 1;

3.6. Environment Canada's National Pollutant Release Inventory (NPRI), 2014;

3.7. Federal Halocarbon Regulations, 2003;

3.8. Ozone-depleting Substances and Halocarbon Alternatives Regulations;

3.9. PCB Regulations (SOR/2008-273);

3.10. Asbestos Regulations (SOR/2007-260);

3.11. DAOD 3003-0, Controlled Goods, Policy direction and the authorities for matters related to controlled goods;

3.12. DAOD 4003-0 Environmental Protection and Stewardship, 1993-03-31;

3.13. DAOD 4003-1 Hazardous Material Management; and

3.14. Transport of Dangerous goods Act, 1992, c 34.

4. REQUIREMENTS

The contractor must provide the labour, material, tools, equipment and storage facilities to conduct all tasks detailed in this Statement of Work. This requirement also include transport, parts production, welding, removal and disposal of hazardous material. The conversion of the Leopard 1C2 MBT will involve controlled good items that are strictly regulated under the Department of National Defence (DND) Controlled Technology Access and Transfer (CTAT) program. All Federal and applicable Provincial policies and regulations with regards to Transportation, Health & Safety, Environment and Disposal requirements will apply. The intent is also to emphasize recycling and to minimize waste materials (solid and liquid) as much as possible in order to reduce the quantity of waste materials destined for landfill.

4.1. Scope of Work

4.1.1. The Contractor must pick-up 22 Leopard 1C2 MBTs from DND facilities at 7 Canadian Forces Supply Depot (CFSD) in Edmonton (195 Ave. 82 St, PO Box 10500 Stn Forces, Edmonton AB, T5J 4J5) and transport the vehicles to the Contractor's facility. Another group of 21 Leopard 1C2 MBTs with an option of 6 additional vehicles, for a maximum of 27 Leopard 1C2 MBTs, located in Montreal will be directly shipped by the Department of National Defence (DND) to the Contractor's location.

4.1.2. All assets identified as controlled must be secured until they are fully destroyed or demilitarized in accordance with the generic or specific instructions.

4.1.3. The Contractor must inspect the vehicles upon arrival at their facility for their general condition and confirm that all radios, communication equipment, weapon and weapon mounts, automatic fire extinguisher bottles (8) have been removed. If any of this equipment is found in the vehicle, the TA will be advised and the equipment will be processed as per TA instructions, Ref Para 2.1.6 Ch. 2.0 for complete instruction on how to process receipts.

4.1.4. The Contractor must remove all hazardous material from the Leopard 1C2 MBTs as part of the conversion process as per this SOW and the Environment Assessment, Ref. para 2.1.3.

4.1.5. The Contractor must remove, demilitarize/destroy and dispose of many items as specified in the appendices. The Contractor must ensure that the demilitarization/destruction of any controlled item removed must render the material non-reusable for its intended purpose, Ref Para 2.1.6 Ch. 2 and 8.9 for complete instructions.

4.1.6. For any controlled items demilitarize/destroy and dispose, the contractor must fill the DND 2556 – Certificate Of Destruction / Demilitarization (Ref Appendix 1 to Annex A, Statement of Work), Refer to Para 2.1.6, Chapter 8.9 for further explanation and detail on scrap materiel.

4.1.7. All destruction should be performed on the contractor's premises. Alternate destruction location may be acceptable but it must be pre-approved by CTAT representative and the TA. For controlled items, contractor specific destruction process may require pre-approval or may have to take place under the supervision and to the satisfaction of the TA or appointed government representative, as requested.

4.1.8. In the event that removed parts cannot be destroyed by the Contractor, the part may have to be return to 7 CFSD Edmonton. The Contractor will notify the TA of the situation and with the support of

DND personnel will be responsible to complete a CF 942 for items returned to DND/CFSD. In preparation for the return of designated pieces of equipment, each piece must be cleaned and identified by the Contractor then inspected by the DND Technical Representative. Upon inspection, the Contractor must prepare the return parts for delivery in accordance with the latest issue of the Canadian Forces Packaging Specification D-LM-008-036/SF-000, DND Minimum Requirements for Manufacturer's Standard Pack, Ref para 2.1.5. The Contractor must package the equipment in quantity of one (1) per package. The equipment will be returned to 7 CFSD as per the Technical Representative instructions.

4.1.9. The Contractor will be responsible to dispose of any residual materials in accordance with all environmental regulations mentioned in the regulations and policies section.

4.1.10. All contaminants, such as oil, grease and fuel must be removed to comply with The Canadian Environmental Protection Act, 1999, C.33. The vehicle will require cleaning to remove any residual hazardous fuels, hydraulic fluids, lubricants, dirt and grime that may have accumulate during the conversion. This will prevent future leaks.

4.1.11. The Contractor must produce/manufacture parts for the conversion of the MBT into a target as per Appendices 2 and 3.

4.1.12. The Contractor will be responsible for the delivery of the total of the (up to 49 for with options) converted Leopard 1C2 targets to CFB Cold Lake at the following location:

AFTTC (Bldg 104)
4 Wing Cold Lake
PO Box 4280 STN Forces
Cold Lake, AB
T9M 2C6

4.2. Schedule and Coordination

4.2.1. The Contractor must be able to prepare and convert vehicles at a minimum rate of 4 vehicles per month.

4.2.2. To confirm that 4.2.1 can be achieved, the Contractor must prepare and deliver a detailed program management plan (PMP) in accordance with CDRL 101 / DID PM-001 that details how the work under the SOW will be managed. The Contractor must implement the approved PMP and ensure that all program management activities are fully integrated with all other plans and activities, such that all schedule, cost and risk elements associated with the work are fully managed and controlled in accordance with the approved plan.

4.2.3. To support the establishment of the PMP, the Contractor must prepare and deliver a Work Breakdown Structure (WBS) in accordance with CDRL 102 / DID PM-002. The Contractor must prepare the WBS in sufficient detail for Canada to monitor the progress of contract deliverables.

4.2.4. The WBS must also be used to establish a Master Program Schedule (MPS) in accordance with CDRL 103 / DID PM-003. The Contractor must amend the approved MPS throughout the term of the contract to reflect current and planned contract activities subject to approval by the TA and CA.

4.2.5. The Contractor may combine the MPS with the WBS.

4.2.6. For every pick-up and delivery the Contractor will prepare a unique transport schedule in the contractor's proposed format. The Contractor will also advise any proposed changes to this schedule a minimum of 30 days in advance. The Contractor will also prepare a delivery schedule for the 27 vehicles that DND will deliver from Montreal to his location. Special provisions will be agreed upon to cater for the thaw period, Ref para 4.3 below.

4.2.7. Project Meetings will be required to ensure Canada is kept up to date on the schedule and progress of the Work.

4.2.7.1. A Kick-off Meeting between Canada and the Contractor will be conducted to go through the PMP, MPS, and WBS and discuss the overall working plan for the contract.

4.2.7.2. The Contractor must host, at its facility, the Kick-off Meeting, co-chaired by the CA, approximately 30 calendar days after Contract award. The Contractor must forward a list of meeting attendees and an agenda for this meeting to the CA no later than seven (7) calendar days prior to the meeting. The TA, or a person with delegated authority, must attend the Kick-off Meeting.

4.2.7.3. Additional informal meetings may be required to discuss the progress of the contract until completion of the Work. The Contractor must host all meetings at its facility unless mutually agreed to by the parties.

4.2.7.4. The Contractor may propose video or telephone conferences in lieu of face-to-face meetings where they may be more convenient. Videoconferences are usually more convenient for meetings of short (less than one (1) day) duration and not requiring hands-on access to equipment or data. Telephone conferences are appropriate when there are few people involved and the duration is not more than about one (1) hour.

4.3. Constraints

4.3.1. Due to the weight of the vehicles and provincial restrictions, transport may not be possible during the thaw period, normally between the end of March and May. The Contractor shall plan the pick-up and delivery of the vehicles according to the thaw period to minimise impact on production.

4.3.2. All Work must be conducted in accordance with the Acts, Regulations, and laws of Canada and those of the province(s) applicable to the contractors' facility in which the Work is conducted.

4.4. DND Support

4.4.1 DND will deliver up to 27 additional vehicles to the contractors location, based on the contractors proposed schedule.

4.4.2 DND will provide training to the contractor in two possible ways:

4.4.2.1 The first and preferred option will be to send to the contractor's location two qualified technicians from Montreal 202 Workshop for a period of one week to train contractor's personnel.

4.4.2.2 The second/alternate option will be for the contractor to send one or two of his technicians to a DND facility in Montreal (202 Workshop Montreal) for their training. The duration of the training will be 5 days on site.

4.4.2.3 Depending on travel restrictions and requirements related to current pandemic, Canada may propose an alternative approach to training if required.

4.4.3 The equipment and the operators required at 7 CFSD Edmonton to place each vehicle onto the transportation truck designated by the Contractor.

4.4.4 Leopard 1 special tooling may be provided (if required and if available).

4.4.5 Technical publications listed in section 2 to support the task (E format).

4.4.6 Coordination between the Contractor and the recipient.

4.4.7 Visit Clearance Request for the pick-up and delivery locations.

4.4.8 Off-loading at CFB Cold Lake.

4.4.9 Technical guidance, as necessary.

4.5. Security requirement

4.5.1. The Contractor must provide a security perimeter with restricted access to the equipment. The Contractor must provide a parking area fenced (6 feet high) with a locked barrier, or provide a hangar where all pieces of equipment will be inside the contractor's premises.

4.6. Space requirement

4.6.1. The Contractor must be capable of receiving large vehicles and multiple assets weighing several tons. The MBTs are of oversize dimensions and will require a large footprint area to work on and to store (for dimensions see Ref. 2.1.1). The contractor's facility must be capable to accommodate up-to 4 Leopard 1C2.

4.7. Hazardous material

4.7.1. The main environmental risks associated with the disposal of the Leopard 1 include polychlorinated biphenyls (PCBs), Asbestos, Ozone Depleting Substances (ODS) (Halon 1301 and 1211), Global Warming Potential (GWP) substance (HFC-134A), Chemical Agent Resistant Coating (CARC), heavy metals, rubber, plastic and electronic wastes in the end item as well as consumables such as fuel, lubricants, adhesives, sealants, batteries, solvents and cleaners used in the maintenance and operation of the end-item. Notwithstanding, there is no significant impact on the environment expected with the appropriate engineering controls in place, the use of qualified personnel, the wearing of required Personal Protective Equipment (PPE), and the use of Environmental Health and Safety (EHS) compliant facilities.

4.7.2. Prior to conversion, demilitarization/destruction of components/assemblies containing hazardous materials must be removed and their hazardous material removed and disposed of IAW the specific rules and regulations for hazardous material, mentioned in paragraph 3 of this SOW. These components are identified in Appendix 2 to Annex A, Statement of Work, Table 1 and also in the Environmental Assessment. It is acceptable that these components be removed concurrently during the conversion provided that precautions are taken to ensure that the components are not damaged are properly disposed of IAW the section 4.7.

4.7.3. Polychlorinated Biphenyls (PCBs). Review of the supporting documentation identified several PCB containing parts (Appendix 2 to Annex A, Statement of Work) within the Leopard MBT which must be removed and disposed as part of this SOW. The bidder must ensure that PCB containing items are removed from the vehicle and disposed in accordance with the *PCB Regulations*. Disposal of PCB items with concentration of 50mg/kg or more must be reported to Environment and Climate Change Canada (ECCC), and a copy provided to DND.

4.7.4. Asbestos. Asbestos Containing Materials (ACMs) may be present in the different configurations of the Leopard 1C2, including the MBT as identified in Appendix 2 to Annex A, Statement of Work. The bidder must ensure that removal of Asbestos is done using proper precautions to prevent exposure to asbestos fibers. The applicable provincial and municipal regulations for asbestos disposal must be consulted and followed.

4.7.4.1. The MBTs' crew compartment fire-extinguishing system (FES) consists of four (4) cylinders (NSN: 1377-21-899-9011) containing 3.5-kg (each) of Halon 1301 (Bromotrifluoromethane or BTM), otherwise known as Freon 13B1. Halon 1301 has an Ozone Depleting Potential (ODP) of 10 and a Global Warming Potential (GWP) of 5,600, (Appendix 2 to Annex A, Statement of Work).

4.7.4.2. The AFES system for the engine compartment consists of four (4) steel cylinders (NSN: 4210-12-148-6952) containing 5.53-kg (each) of Halon 1211 (Bromochlorodifluoromethane), also known

as Freon 12B1. Halon 1211 has an ODP of 3 and a GWP of 1,300 (Appendix 2 to Annex A, Statement of Work).

NOTE: All fire-extinguishing system will be removed prior to the contractor picking up the vehicles. The contractors will NOT have to demilitarise any fire-extinguishing system.

4.7.4.3. Compressed nitrogen gas. Nitrogen Gas (N2) is located in the commander's hatch, the recuperator, the fording (submergence) hydraulics and the pressure accumulator, the turret hydraulic system (main and hand elevation) and the service brake.

4.7.5. Chemical Agent Resistant Coating (CARC). The Leopard 1 may have several different variants of a CARC on the exterior (i.e. American, Canadian and/or German). Some of the primers used in CARC may contain hexavalent chromium, a known carcinogen. If CARC topcoats are heated above 170°C, for instance during welding, grinding or sanding activities, the urethane chemical linkages start to decompose and hazardous decomposition products (isocyanates) are released. If the primer contains hexavalent chromium, it may also be liberated.

4.7.5.1. A cured CARC topcoat is not considered a hazardous material (hazmat). The curing also means that the CARC has been demilitarized (and thus CTAT does not apply). As such, the coating need not be removed. The hazards associated with CARC are present only when heat is applied or if incineration of CARC treated items is undertaken.

4.7.5.2. If the items are to be scrapped, this must be done in accordance with Ref para 2.1.6 Chap. 8. Further, the coating need not be removed and waste metal scrap can be disposed of through contractors who then process the metal for recycling versus landfills.

4.7.6. Fluids, Lubricants and Compressed Gas. The fluids and lubricants utilized by the Leopard 1 are predominantly commercially available products. All fuel, oil and hydraulic fluids must be removed from all vehicles. The following components and their pipelines and/or hoses, must be drained:

- 4.7.6.1. Power Pack (Engine and Transmission);
- 4.7.6.2. Cooling System complete;
- 4.7.6.3. Final Drives;
- 4.7.6.4. Fuel Tanks (Fuel tanks must be purged);
- 4.7.6.5. Brake System (drain oil and nitrogen);
- 4.7.6.6. Fording Hydraulics;
- 4.7.6.7. Commander's Seat Hydraulics;
- 4.7.6.8. Traverse Drive Unit (must be purged);
- 4.7.6.9. Hydraulic Pump Unit (including Main and Hand Elevation Accumulators);
- 4.7.6.10. Elevation Cylinder (including Elevation and Azimuth Servo block);
- 4.7.6.11. Recuperator; and
- 4.7.6.12. Recoil Cylinder.

4.7.7. The volume capacities of fluids was compiled from the data summary as follows and are representative of approximate quantities:

Table 1: Volume of fluid

COMPONENT	QUANTITY (L)
Engine	54
Transmission	105
Final Drive	3.5
Cooling System	165

Fuel Feeder Tank	30
Right Fuel Tank	475
Left Fuel Tank	480
Brake System	105
Turret Hydraulic System	20
Commander's Seat	0.34
Fording Hydraulics	1.5

NOTE: The Leopard 1 has been known to leak fuel and lubricants. The residue must be recovered and disposed of as hazardous waste.

4.7.8. Batteries

4.7.8.1. The batteries must be removed and disposed of IAW Hazmat specific instructions.

5. **LEOPARD 1 ITEMS DEMILITARIZATION/DESTRUCTION PROCEDURES.**

5.1. Demilitarization is costly and should be avoided where possible. The demilitarization only applies to controlled goods. Where necessary, the preferred method of demilitarization/destruction is by mechanical shearing or by torch cutting with metal displacement. All cuts will completely sever the item, the item will be made non-repairable for its intended use. Shearing, crushing or melting may be utilized when such methods of demilitarization/destruction are deemed more cost effective and/or practicable, Ref Appendix 2 table 1 and Appendix 3 table 1 components.

5.2. Return of designated pieces of equipment

5.3.1 In the event that removed parts cannot be destroyed by the Contractor, the parts will be returned to CFSD. In preparation for the return of designated pieces of equipment, each piece must be cleaned and identified by the Contractor then inspected by the DND Technical Representative. Upon inspection, the Contractor must prepare the return parts for delivery in accordance with the latest issue of the Canadian Forces Packaging Specification D-LM-008-036/SF-000, DND Minimum Requirements for Manufacturer's Standard Pack, Ref para 2.1.5. The Contractor must package the equipment in quantity of one (1) per package. The equipment will be returned to CFSD as per the Technical Authority instructions.

5.3. Disposal of Residual Equipment

5.3.1 The Contractor will be responsible to dispose of all items in accordance with directives and regulations.

Appendix 1 to Annex A, Statement of Work DND2556 – Certificate of Destruction / Demilitarization

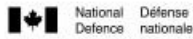

Certificate of Destruction / Demilitarization

Part 1 - Identification

Part 1-A (applicable only to items with a DMC A or Q)

Stock code	Quantity	Applicable references (i.e. CFTO, DIR, etc.)
Destruction method used (i.e. crushing, shredding, smelting, etc.)		
Destruction criteria used (i.e. break in two pieces, shred to a size of... etc.)		
Remarks: Destruction for DMC "A" items is not a requirement, unless there are contractual obligations or other directives requiring their destruction. DMC "Q" items are subject to export control. Destruction is required, unless the items can be transferred to an authorized person.		

Part 1-B (applicable only to items with a DMC D)

Stock code	Quantity	Applicable references (i.e. CFTO, DIR, etc.)
Demilitarization method used (i.e. crushing, shredding, smelting, etc.)		
Demilitarization criteria used (i.e. break in two pieces, shred to a size of... etc.)		
Remarks: DMC D items are subject to the Defense Production Act. Full demilitarization is required, unless the items can be transferred to an authorized person. Informal demilitarization instructions from the item's TA or the use of Generic Demilitarization Instructions is required.		

Part 1-C (applicable only to items with a DMC F)

Stock code	Quantity	Applicable references (i.e. CFTO, DIR, etc.)
Remarks: Remarks: DMC F items are subject to the Defense Production Act. Full demilitarization is required, unless the items can be transferred to an authorized person. Formal demilitarization instructions from the item's TA is required.		

Part 2 - Certification

Part 2-A (applicable only to Part 1-A)

I certify that the above item/items (attached list) was/were destroyed in accordance with the Technical Authority's instructions prior to disposing of them as scrap.

Part 2-B (applicable only to Part 1-B)

I certify that the above item/items (attached list) was/were fully demilitarized in accordance with CFTO "C-01-008-000/MD-000, GENERIC DEMILITARIZATION INSTRUCTIONS" or informal demilitarization instructions received or authorized by the item's TA.

Part 2-C (applicable only to Part 1-C)

I certify that the above item/items (attached list) was/were demilitarized in accordance with FORMAL demilitarization instructions provided or authorized by the item's TA.

Part 3 - Signatures

Destruction / Demilitarization performed by:		Destruction / Demilitarization witnessed by:	
Print name:		Print name:	
Position title:		Position title:	
Organization name:		Organization name:	
Date of destruction / demilitarization (yyyy-mm-dd):		Date witnessed (yyyy-mm-dd):	
Signature:		Signature:	

Instructions

Part 1 - Identification

Part 1-A (use for DMC "A" or "Q" only)

<u>Stock code:</u>	List the NSN(s)/PSCN(s) or part number for destruction.
<u>Quantity:</u>	Indicate the number of items (same stock code) slated for destruction.
<u>Applicable references:</u>	Record reference(s) used for the destruction of the item(s), i.e. destruction instructions, directives, technical orders, etc.
<u>Destruction method used:</u>	Record the chosen method of destruction. Examples of methods include, but are not limited to: Breaking, crushing, cutting (metal displacement), cutting (other types), neutralizing, punching, shattering/pulverizing, shredding, smelting, or burning.
<u>Destruction criteria used:</u>	Record the destruction' criteria. Examples of criterion may include size and/or quantity, such as 1/4 inch pieces or 10 pieces, etc.
When multiple line items are being destroyed, a list of items, with their quantity, reference, method and criteria (recorded for each); shall be attached as an annex to the certificate.	
Important: For weapons, in addition to the NSN/PSCN, the serial numbers must be recorded.	

Part 1-B (use for DMC "D" only)

<u>Stock code:</u>	List the NSN(s)/PSCN(s) or part number for demilitarization.
<u>Quantity:</u>	Indicate the number of items (same stock code) being demilitarized.
<u>Applicable references:</u>	Record reference(s) used for the demilitarization of the item(s), i.e. demilitarization instructions, directives, technical orders, etc.
<u>Destruction method used:</u>	Record the method of demilitarization used. Examples of methods include, but are not limited to: Breaking, crushing, cutting (metal displacement), cutting (other types), neutralizing, punching, shattering/pulverizing, shredding, smelting, or burning.
<u>Destruction criteria used:</u>	Record the demilitarization' critena. Examples of criterion may include size and/or quantity, such as 1/4 inch pieces or 10 pieces, etc.
When multiple line items are being destroyed, a list of items, with their quantity, reference, method and criteria (recorded for each); shall be attached as an annex to the certificate.	
Important: For weapons, in addition to the NSN/PSCN, the serial numbers must be recorded.	

Part 1-C (use for DMC "F" only)

<u>Stock code:</u>	List the NSN(s)/PSCN(s) or part number for demilitarization.
<u>Quantity:</u>	Indicate the number of items (same stock code) being demilitarized.
<u>Applicable references:</u>	Record reference(s) used for the demilitarization of the item(s) i.e. demilitarization instructions, directives, technical orders, etc. Reference to formal demilitarization instructions is mandatory.

Part 2 - Certification

Part 2-A (applicable only to Part 1-A)

Check the certification that correspond to your selection in Part 1, i.e. check certification 2-A where Part 1-A was fill, 2-B if 1-B, or 2-C if 1-C
--

Part 3 - Signatures

<u>Performed by:</u>	This block must be signed by the individual who destroyed or demilitarized the materiel.
<u>Witnessed by:</u>	This block must be signed by the individual who witnessed the destruction or demilitarization of the materiel.
N.B.: There is no need to witness destruction for DMC "A" or "Q" items, unless specified otherwise. However, demilitarization of DMC D and F shall be witnessed. The requirement to have DND/CAF personnel physically witnessing the demilitarization is only required where the person/company performing the demilitarization is not authorized to access controlled goods. If the party selected to demilitarize the items is authorized, the witnessing can be done by an entity other than DND/CAF.	

**Appendix 2 to Annex A,
Statement of Work - SUMMARY OF HAZARDOUS MATERIAL**

The following items in table 1 includes hazardous materials that must be removed from all the Leopard 1 and disposed according to regulations and laws.

Table 1: Items that contain hazmat that can be found on the vehicles

NSN	DESCRIPTION	HAZMAT	CFTO
5910-12-152-4388	capacitor part of scavenger motor NSN 1015-12-341-9929	PCB	C71278000MX000
5910-12-158-1682	Capacitor part of bilge pump NSN 4320-12-142-9975 (Power pack compartment and Crew)	PCB	C30731K22MY001
5910-12-163-0349	capacitor, part of heater NSN 2540-12-311-6771	PCB	C30731K22MY001
5910-12-173-7824 5910-12-173-9010 6105-12-158-1674	capacitor, part of the Dust Ejection NBC blower motor	PCB	C30731K22MY001
5910-12-175-2860 5910-12-151-5082 6105-12-158-1675	capacitor, part of NBC Main blower motor	PCB	C30731K22MY001
4210-12-148-6952	cylinder halon 1211(should already be removed)	ODS	C30730000MN001
1377-21-899-9011	cylinder halon 1301, (should already be removed)	ODS	C30730000MN001
1015-12-177-1658	thermal barrel jacket upper(may have been replaced by non- asbestos part)	ASBESTOS	C71345000MD001
1015-12-156-1381	thermal barrel jacket lower, (may have been replaced by non- asbestos part)	ASBESTOS	C71345000MD001
1015-12-156-1379	thermal barrel jacket upper, (may have been replaced by non- asbestos part)	ASBESTOS	C71345000MD001
1015-12-146-9442	thermal barrel jacket assy, (may have been replaced by non- asbestos part)	ASBESTOS	C71345000MD001
2990-12-143-0297	pipe exhaust, (may have been replaced by non-asbestos part)	ASBESTOS	C30730000MY000
2990-12-142-8800	manifold exhaust, (may have been replaced by non-asbestos part)	ASBESTOS	C30730A00MY001
2990-12-142-8801	manifold exhaust, (may have been replaced by non-asbestos part)	ASBESTOS	C30730A00MY001
2990-12-142-8798	manifold exhaust, (may have been replaced by non-asbestos part)	ASBESTOS	C30730A00MY001
2990-12-142-8799	manifold exhaust, (may have been replaced by non-asbestos part)	ASBESTOS	C30730A00MY001
2990-12-142-8797	collar exhaust, (may have been replaced by non-asbestos part)	ASBESTOS	C30730A00MY001

For the PCB, the vehicles may be labelled with the below stickers:

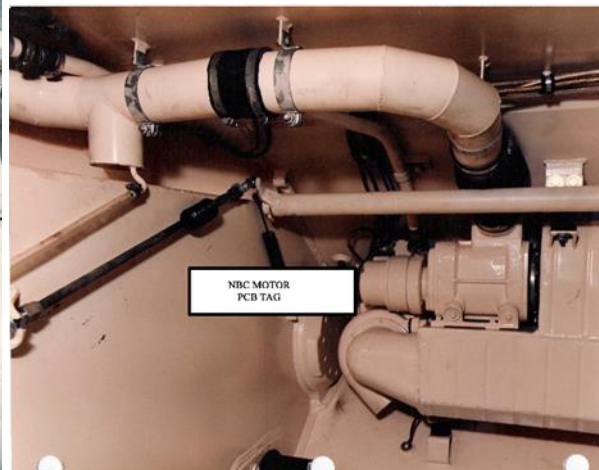
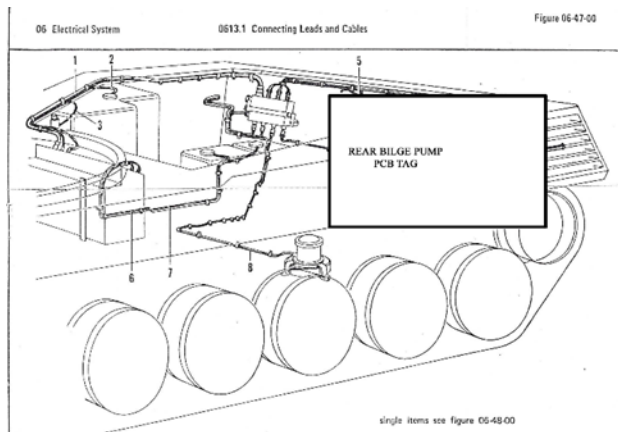
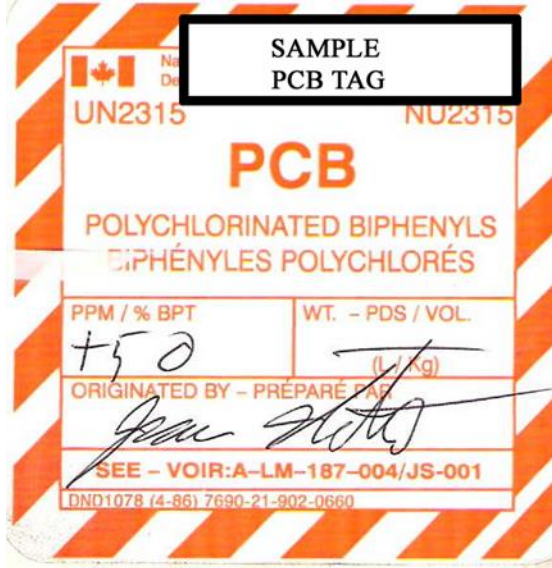

**Appendix 3 to Annex A,
Statement of Work - LEOPARD FAMILY OF VEHICLES CHASSIS**

Reference documents:

Environmental assessment NSN 2350-21-920-4873 Leopard 1C2, Main Battle Tank (MBT)
Including NSN 2510-12-346-9544 MBT Turret, 2184-01267-02 VOL 0002 (DLEPS 6/DGLEPM – 2843),
31 July 2014

C-30-730-000/MN-001, First and second line maintenance instructions leopard 1

C-30-730-000/MS-001, Operating and maintenance instructions - test equipment hydraulic systems

C-30-730-000/MX-001, LEOPARD C1 family of vehicles common items

C-30-730-000/MY-000, LEOPARD C1 Illustrated parts list

C-30-730-000/TP-002, LEOPARD 1 Fuel Tanks

C-30-731-000/MN-001, First and Second line maintenance instructions leopard 1C2 MBT

C-30-731-000/MX-000, LEOPARD C1, Main Battle Tank

C-30-731-000/MY-000, LEOPARD C1 - illustrated parts list for hull and suspension main battle tank

1. The following components in table 1 must be removed from all Leopard 1C2 chassis.

Table 1: Parts removal

NSN	NOMENCLATURE	Remarks	DMC
2815-12-142-0226	Power pack	Remove pack from hull, remove Hazmat and then secure back in hull	Q
6140-12-190-9027	Batteries	Remove and dispose	A
2910-12-155-8344	Bladder fuel cell left	Remove fluids, destroy	Q
2910-12-155-8345	Bladder fuel cell right	Remove fluids, destroy	Q
2910-12-156-5163	Feeder tank	Remove fluids, destroy	Q
2540-12-311-6771	Heater	Remove Hazmat and dispose	A

Required Modification and Material production

2. The following modifications are required to be completed as part of the vehicle conversion.
 - 2.1. In order to prevent water build-up and prevent rodents from entering the vehicle the following will be completed:
 - 2.1.1. Secure the crew escape hatch by welding the handle in position, as shown in the picture below.
 - 2.1.2. Cut the drain plug and lever.

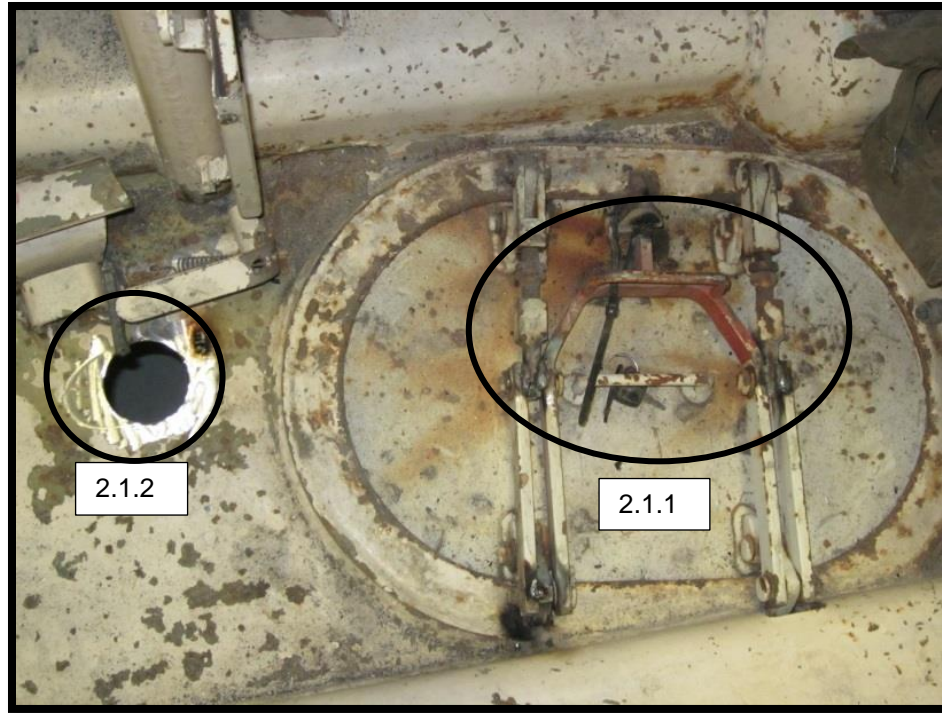

2.1.3. Three drainage plates will require fabrication, 1 x 5 inches plate and 2 x 9 inches plate, (alternative solution will be considered):

2.1.3.1. The 5 inches plate will be installed and welded in the crew compartment and the 2 x 9 inches will be welded in the engine compartment, as per pictures below.

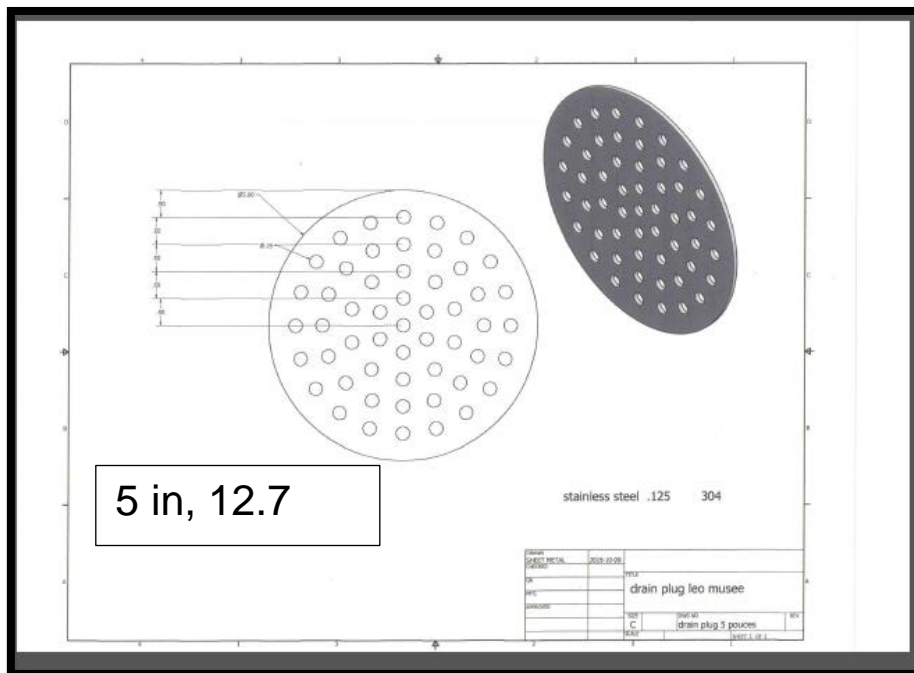

- 2.1.3.3. Install on the opposite side the 9 inches plate (22.8 cm) # 108083353 at the back as shown below. Weld in three locations at angle with 3/16 (4.8mm) diameter and 2.5 in (6.3cm) long.

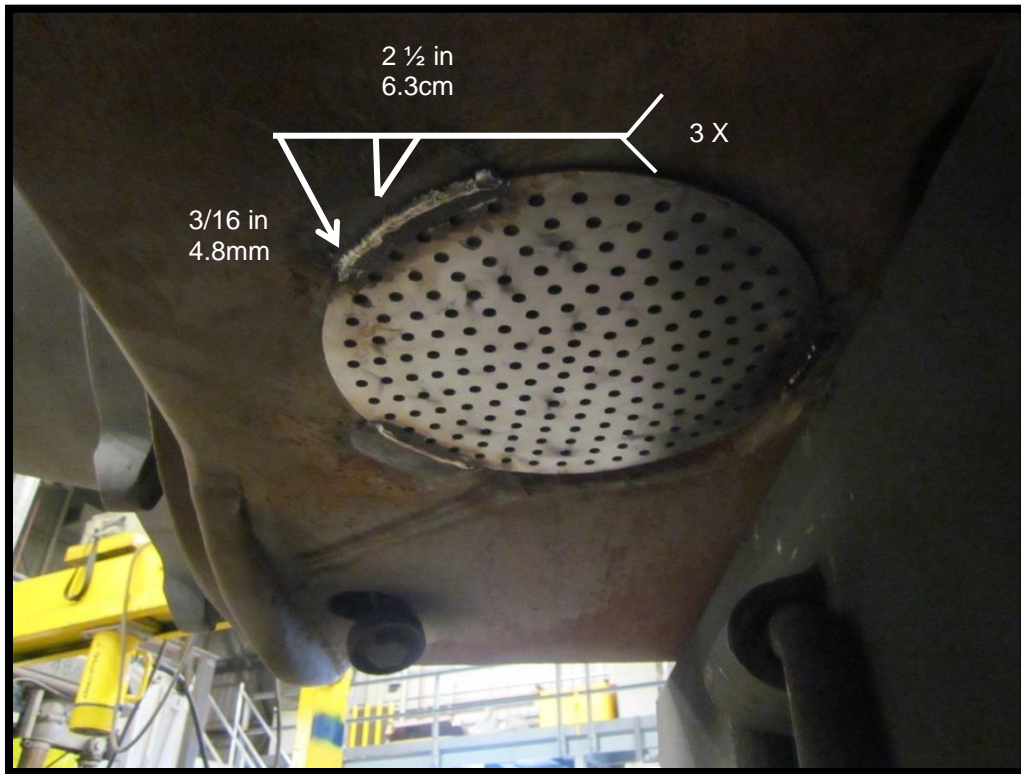

- 2.1.3.4. Install the 5 in plate (12.7 cm) # 108129547 in the crew compartment by the escape hatch.

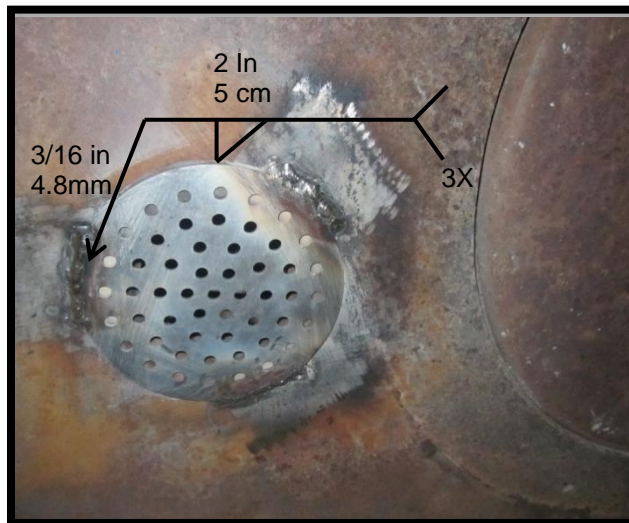

- 2.2. The last part to complete will be to weld the hatches and stowage compartment closed. For the Commander and Loader hatches, weld three plates in order to secure the hatch. Cut the locking part of the handle and weld in place. (Appendix 3 need to be completed before this step).

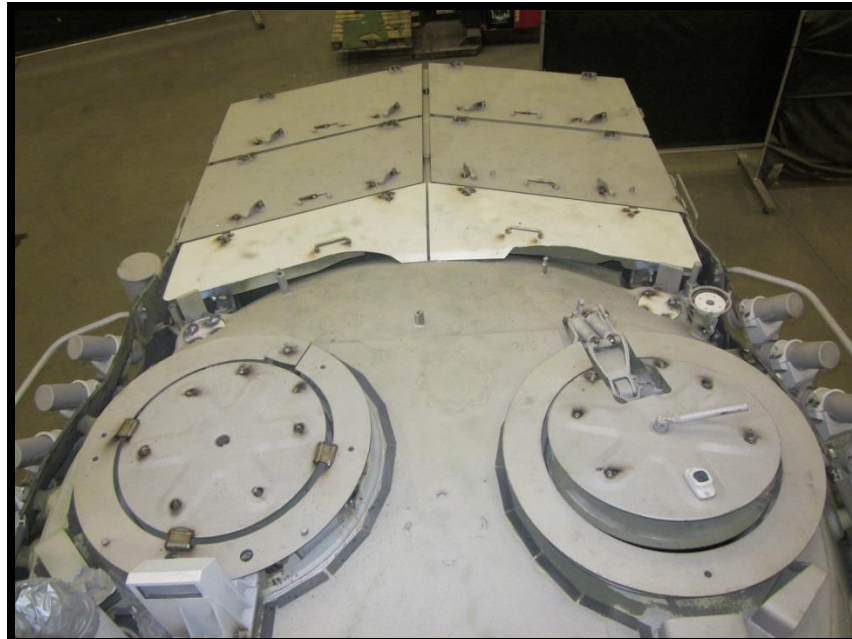

- 2.3. For the Drivers hatch, close the hatch and weld the hatch locking mechanism in place.



Appendix 4 to Annex A, Statement of Work - LEOPARD 1C2 TURRET

Reference Documents

Environmental assessment NSN 2350-21-920-4873 Leopard 1C2, Main Battle Tank (MBT) Including NSN 2510-12-346-9544 MBT Turret, 2184-01267-02 VOL 0002 (DLEPS 6/DGLEPM – 2843), 31 July 2014;

C-71-345-000/MA-001 data summary - turret, leopard C2 tank;
C-71-345-000/MD-001 equipment description - leopard C2 tank;
C-71-345-000/MM-001 first line maintenance - leopard C2 turret;
C-71-345-000/NR-001 first line inspections - leopard C2 turret;
C-71-278-000/MA-000 data summary - ordnance 105 mm tank gun;
C-71-278-000/MD-000 equipment description - leopard C1, MBT;
C-71-278-000/MM-000 first line maintenance instructions;
C-71-278-000/MN-000 second line maintenance instructions;
C-71-278-000/MX-000 leopard C1, armament;
C-71-278-000/MY-000 illustrated parts list - leopard C1 arm;
C-71-278-000/MY-001 data summary - telescope panoramic trp2a;
C-73-244-000/MY-000 illustrated parts list for telescope pan;
C-73-244-000/MY-001 illustrated parts list leopard C1 MBT;
C-73-255-000/MD-000 equipment description - telescope articulated;
C-73-255-000/NP-001 telescope articulated tzf 1A 1240-12-172;
C-73-256-000/MA-000 data summary - electrical slave drive TE;
C-73-256-000/MD-000 equipment description - TEW 1A synchro servo;
C-73-259-000/MD-000 equipment description - leopard C1, MBT;
C-73-259-000/MX-001 leopard C1 turret; and
C-73-244-000/MA-000 leopard C1 tank 105 mm ordnance, 17A3.

1. In order to prepare the turret as a target the following will need to be completed:
2. Inspect the turret interior for any Wpn and Wpn mounts. All small arms and their respective mounts should have been removed prior to shipment to the contractor. If any small arms and/or their respective mounts are found in the vehicle, the TA will be advised and the equipment will be processed as per TA instructions;
3. The turret will need to be secure in place by welding the gun, the mantlet and turret to the hull.
4. The Breech Rings, Breech Chambers, Breech Couplings, Breech Blocks, Breech Housings, Breech Yokes, Breech Plugs, and Firing Mechanisms must be cut through with the Breech Block in the closed position and through the firing mechanism. Equivalent cutting of the breech ring, breech chamber, breechblock and firing mechanism as separate items is acceptable;
5. Demilitarisation of the cannon external part:
 - 5.1. In order to block the cannon, install a 4 x 3/16 inches (10.1 cm X 4.8mm) steel plate ½ in (13mm) inside the cannon muzzle end and weld it. The weld should be of ¼ in (6.4mm). at a 45 deg. angle.

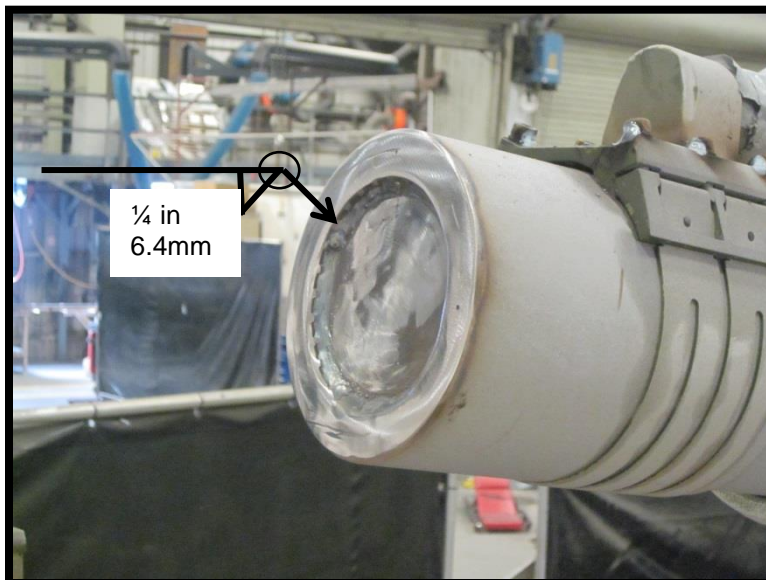

5.2. Drill a hole then cut a $2\frac{1}{2}$ '' X $5\frac{1}{2}$ '' in the gun chamber as shown below.

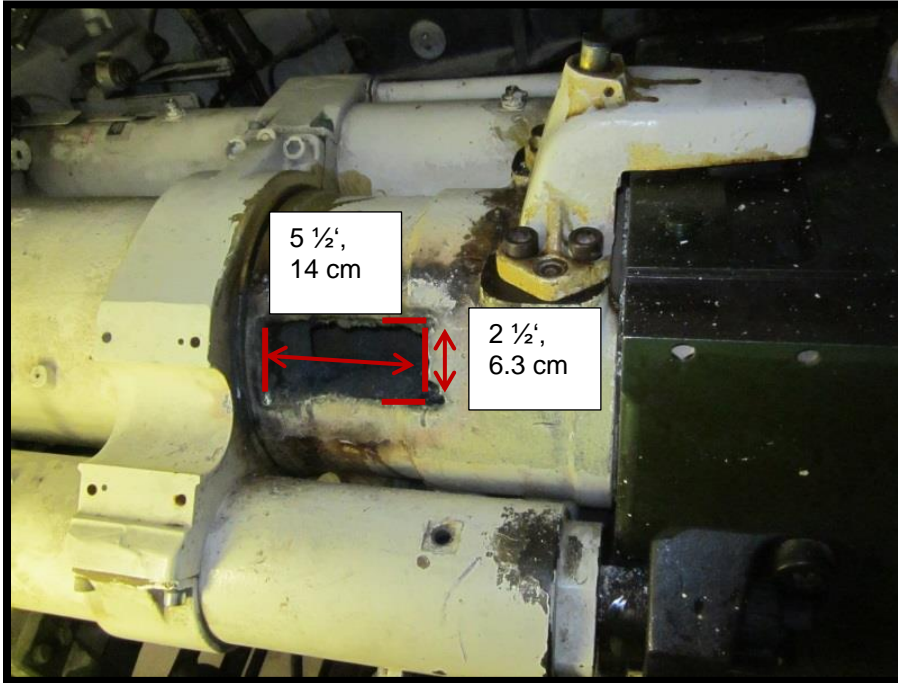

5.3. Weld the Breech Ring to the Mount, Lenght approx 5cm (2 1/2in.)

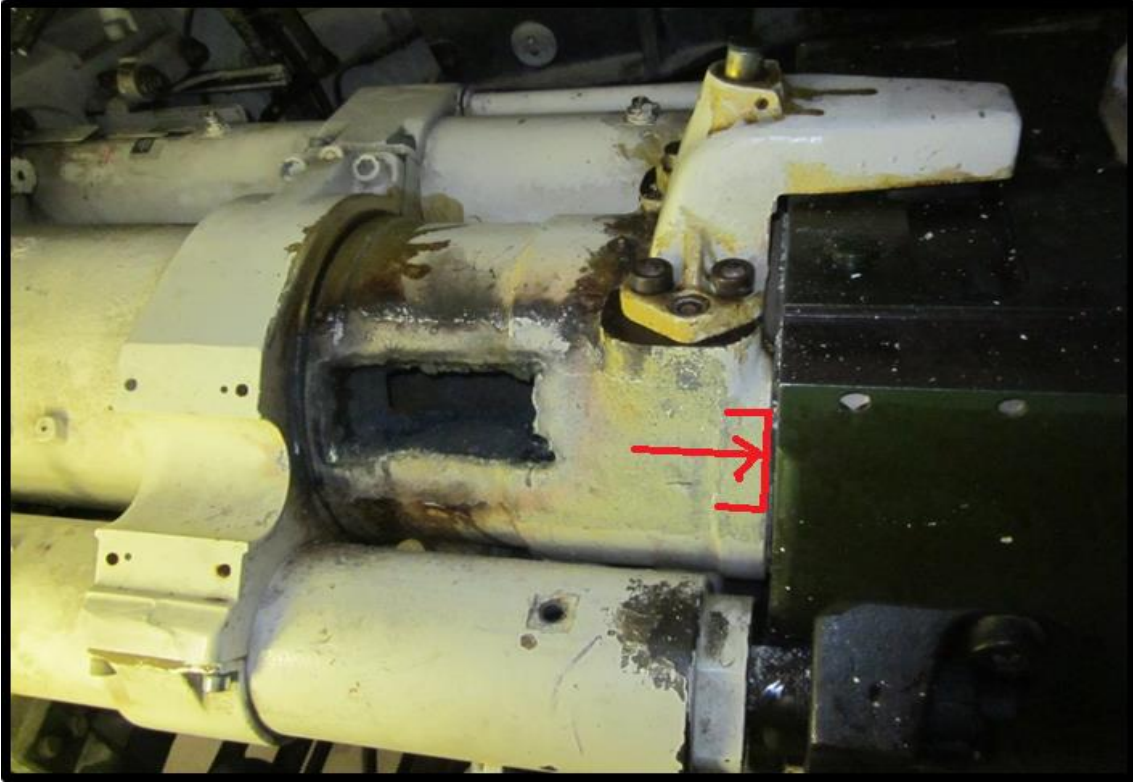

5.4. Remove the breech block, remove the cap item 37, remove and discard needle assy item 39, see diagram at para 5.6 below.

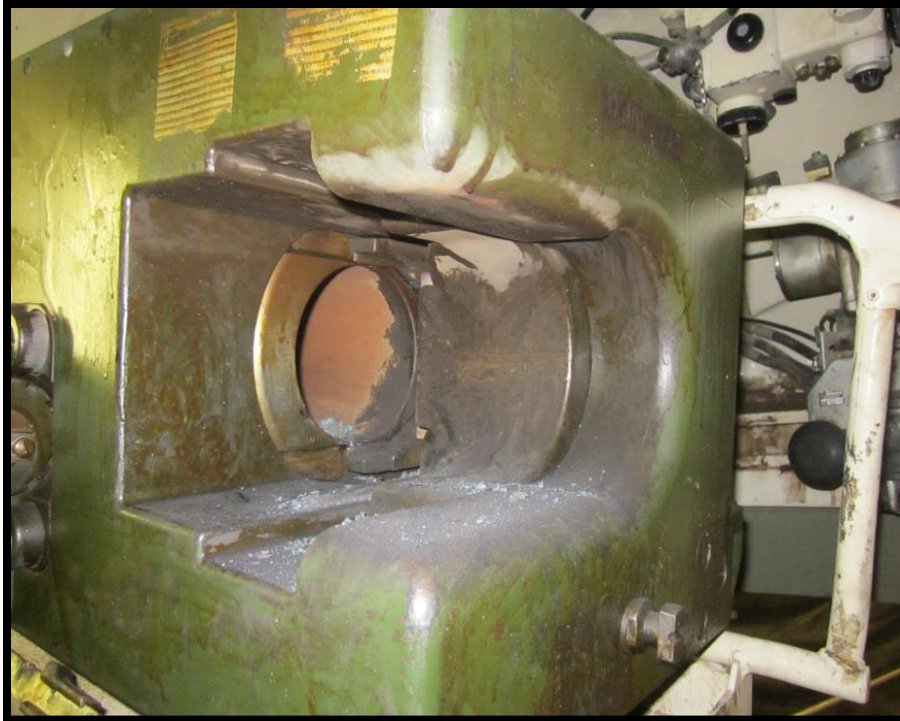

5.5. Replace the cap item 37 and weld the cap to the breech block, replace the breech block and weld the breech block (closed position) to the breech ring.

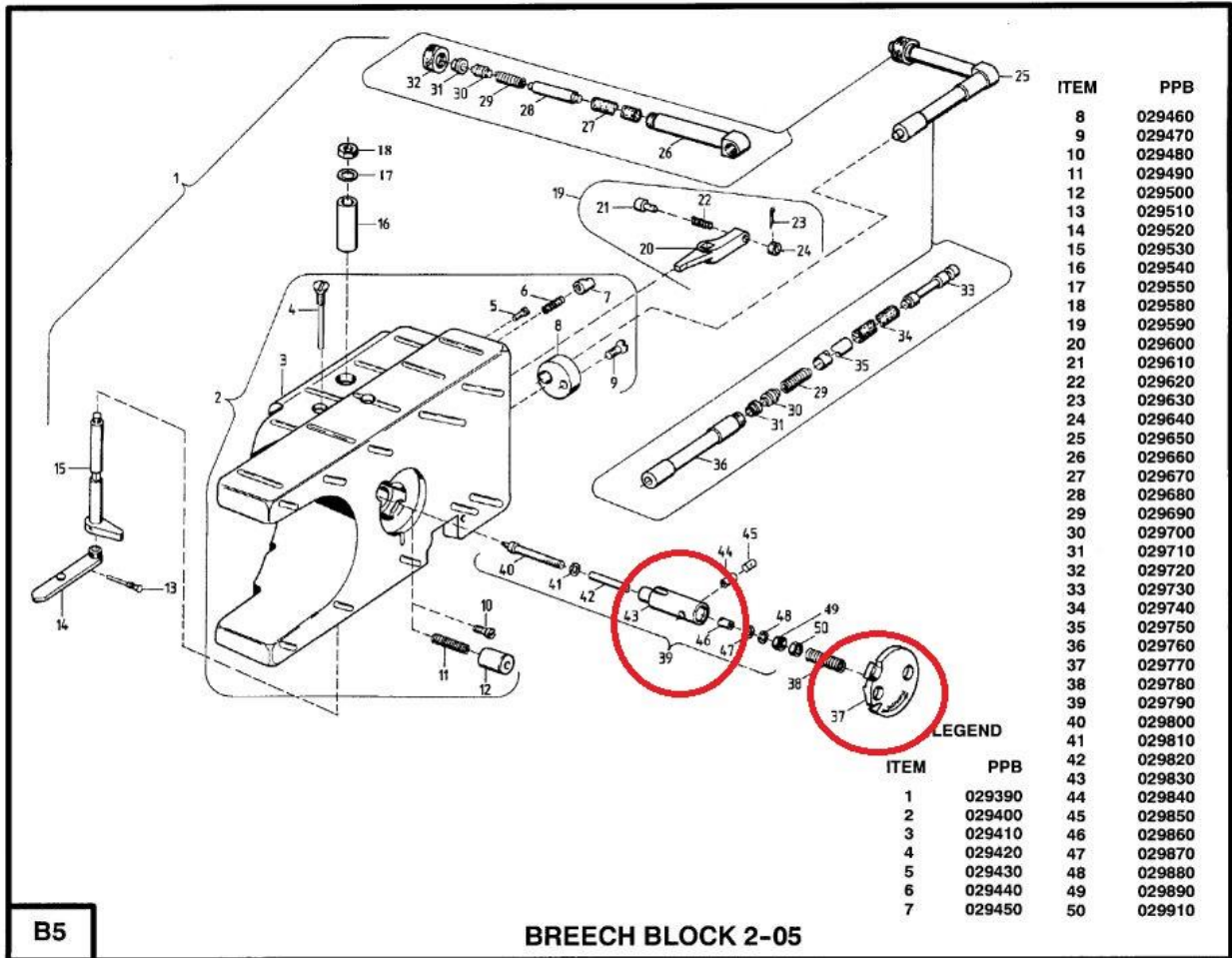

B5

BREECH BLOCK 2-05

5.6. Cut 8 teeth for the turret gear.



5.7. For the MBT targets the main gun will be secured in place at 0 Deg elevation. In order to secure the gun a support will be installed between the breech ring and the turret roof:

5.7.1. For a Gun elevation of 0 Deg use the 7 ½ in (19 cm) support below.

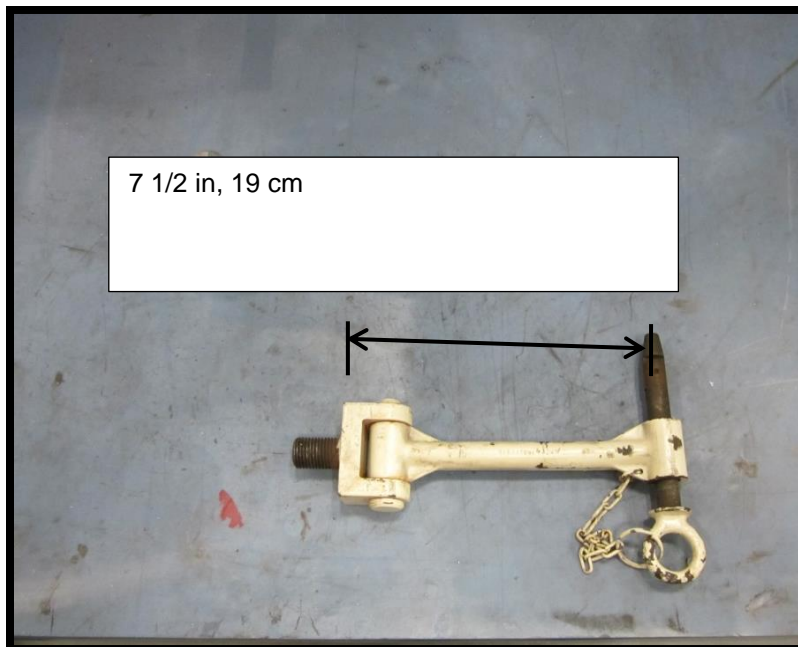
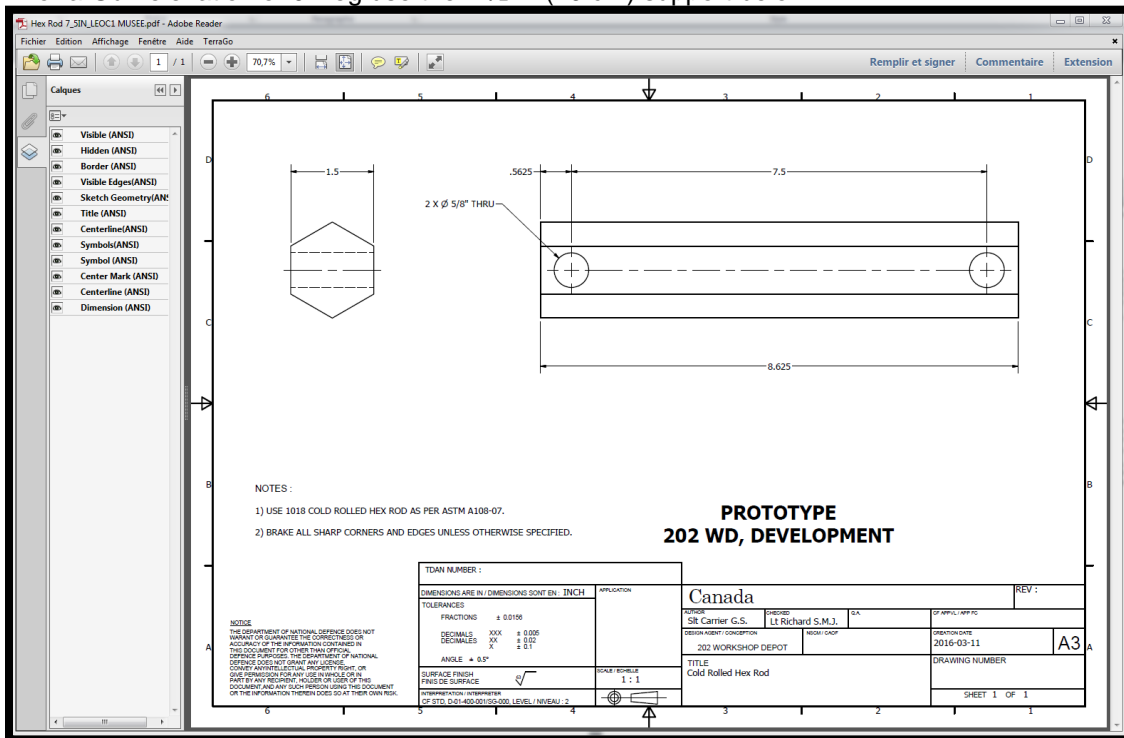

length of 7 ½", 19 cm.

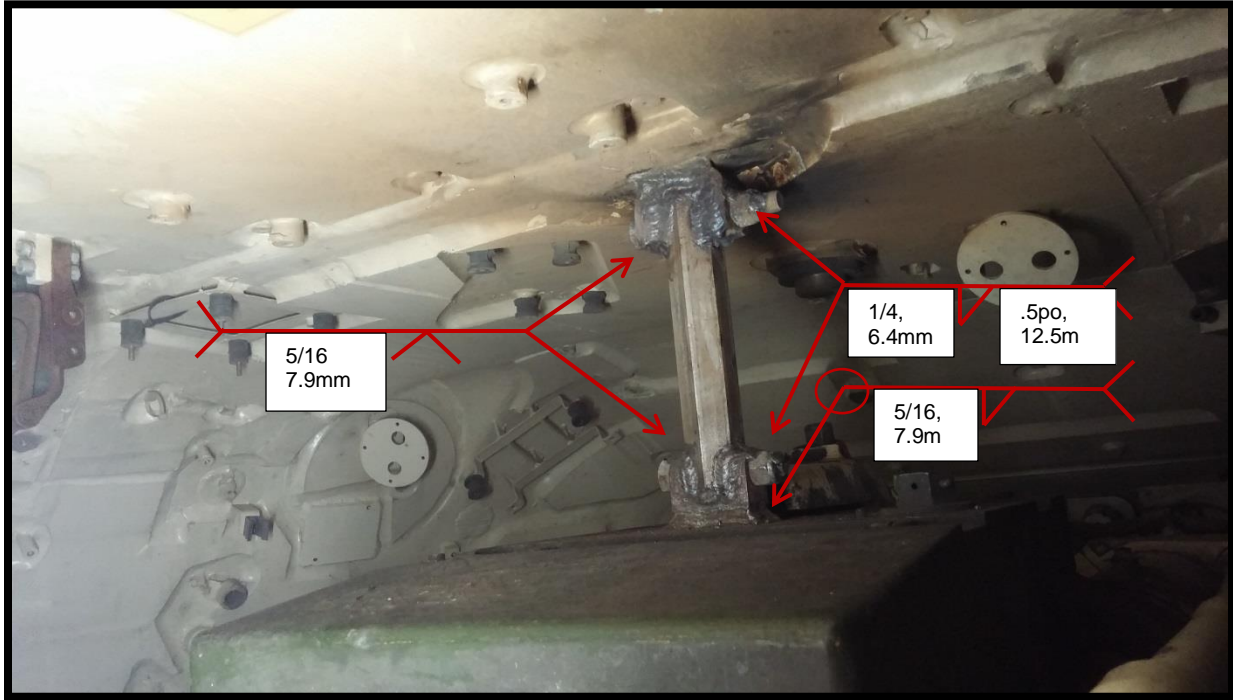

5.8. Fix the turret at the desired position and weld the turret locking mechanism in place.

5.8.1. Weld in 2 places at angle as shown below.

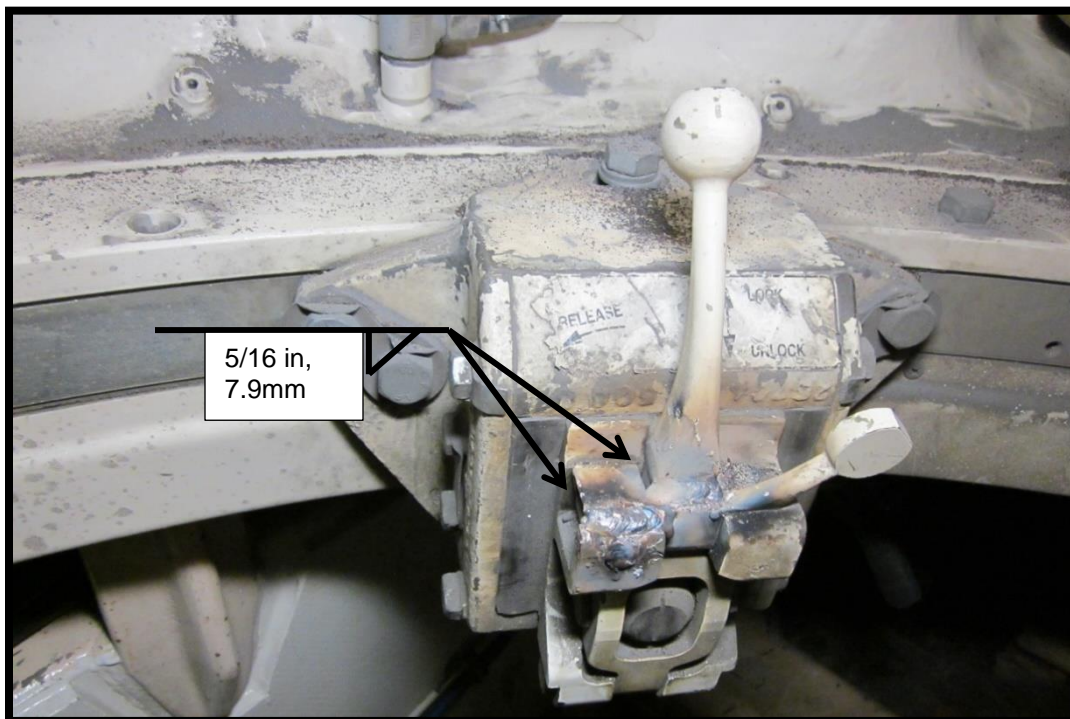

5.9. The Sight and the MG hole in the mantlet will require to be plugged. A plug will need to be fabricated to plug the holes.

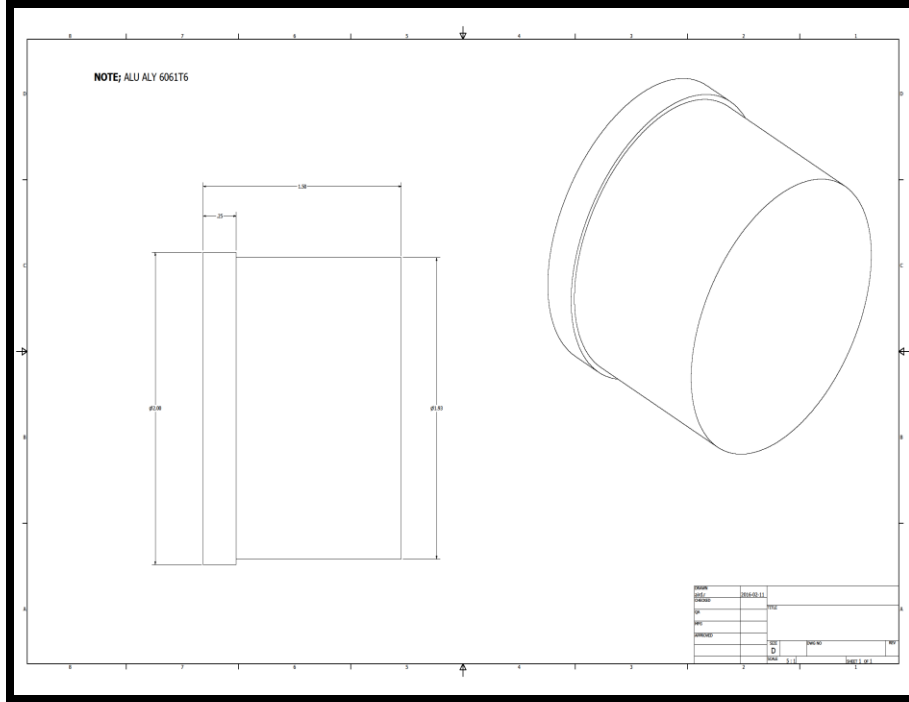

5.10. The plugs will be installed and welded in place



Appendix 5 to Annex A

Contract Data Requirements List (CDRLs)

LEOPARD 1C2 TANK CONVERSION TO TARGET

Requisition Number:

DND Document # W8486-217668/A

Date: 20-11-2020

RDIMS #

	NOTICE This documentation has been reviewed by the technical authority and does not contain controlled goods.
	AVIS Cette documentation a été révisée par l'autorité technique et ne contient pas de marchandises contrôlées.

Prepared by:

National Defence Headquarters
Major General George R. Pearkes Building
Ottawa, Ontario
K1A 0K2

LIST OF CDRLs and DIDs

CDRL	DID	Title	Short title
101	PM-001	Project Management Plan	PMP
102	PM-002	Work Breakdown Structure	WBS
103	PM-003	Master Program Schedule	MPS

CONTRACT DATA REQUIREMENTS LIST (1Data Item) DND Form 1413											
A. SYSTEM / ITEM LEOPARD 1C2 TANK CONVERSION TO TARGET				B. CONTRACT / RFP NUMBER							
C. SOW IDENTIFIER SOW_ID		D. DATA CATEGORY Program Management		E. CONTRACTOR							
1. ITEM NUMBER 101		2. TITLE OR DESCRIPTION OF DATA Program Management Plan		3. SUBTITLE PMP							
4. AUTHORITY (Data Item Number) PM-001		5. CONTRACT REFERENCE SOW Paragraph 4.2		6. REQUIRING OFFICE DND PM (TA)							
7. INSPECTION SD	9. INPUT	10..FREQUENCY See Section 16	12. DATE OF 1 st SUBMISSION ASGEN	14. DISTRIBUTION and ADDRESSEES							
8. APP CODE	11. AS OF DATE See section 16	13. DATE OF next SUBMISSIONS See section 16	A. ADDRESS	B. COPIES							
				DRAFT		FINAL					
				Hard	Soft	Hard	Soft				
16. REMARKS <u>Timelines:</u> <ul style="list-style-type: none"> The proposed PMP will be reviewed during the kick-off meeting. The Contractor shall finalize and submit the PMP within ten (10) working days of the kick-off meeting. Response Time: Canada will provide comments on the PMP within ten (10) working days of receipt. The Contractor shall update and re-submit the PMP on as necessary. 				DND PM	1	1	1	1			
PREPARED BY XXX		APPROVED BY PM									
DATE		DATE									
17. CONTRACT FILE/DOC NUMBER	18. ESTIMATED NO OF PAGES	19. ESTIMATED PRICE	15. TOTAL	1	1	1	1				

CONTRACT DATA REQUIREMENTS LIST (1Data Item) DND Form 1413							
A. SYSTEM / ITEM LEOPARD 1C2 TANK CONVERSION TO TARGET				B. CONTRACT / RFP NUMBER			
C. SOW IDENTIFIER SOW_ID		D. DATA CATEGORY Program Management		E. CONTRACTOR			
1. ITEM NUMBER 102		2. TITLE OR DESCRIPTION OF DATA Work Breakdown Structure		3. SUBTITLE WBS			
4. AUTHORITY (Data Item Number) PM-002		5. CONTRACT REFERENCE SOW Paragraph 4.2		6. REQUIRING OFFICE DND PM (TA)			
7. INSPECTION SD	9. INPUT	10..FREQUENCY See section 16	12. DATE OF 1 st SUBMISSION ASGEN	14. DISTRIBUTION and ADDRESSEES			
8. APP CODE		11. AS OF DATE See section 16	13. DATE OF next SUBMISSIONS See section 16	A. ADDRESS		B. COPIES	
16. REMARKS <u>Timelines:</u> <ul style="list-style-type: none"> The proposed WBS will be reviewed during the kick-off meeting. The Contractor shall finalize and submit the WBS at least ten (10) working days before the kick-off meeting. Response Time: Canada will provide comments on the WBS within ten (10) working days of receipt. The Contractor shall update and re-submit the WBS on a monthly basis and after each milestone change. 							
				DND PM		1	1
PREPARED BY XXX		APPROVED BY PM					
DATE		DATE					
17. CONTRACT FILE/DOC NUMBER		18. ESTIMATED NO OF PAGES		19. ESTIMATED PRICE		15. TOTAL	
						1	1
						1	1

CONTRACT DATA REQUIREMENTS LIST (1Data Item) DND Form 1413							
A. SYSTEM / ITEM LEOPARD 1C2 TANK CONVERSION TO TARGET				B. CONTRACT / RFP NUMBER			
C. SOW IDENTIFIER SOW_ID		D. DATA CATEGORY Program Management		E. CONTRACTOR			
1. ITEM NUMBER 103		2. TITLE OR DESCRIPTION OF DATA Master Project Schedule (MPS)		3. SUBTITLE MPS			
4. AUTHORITY (Data Item Number) PM-003		5. CONTRACT REFERENCE SOW Paragraph 4.2		6. REQUIRING OFFICE DND PM (TA)			
7. INSPECTION SD	9. INPUT	10..FREQUENCY See section 16	12. DATE OF 1 st SUBMISSION ASGEN	14. DISTRIBUTION and ADDRESSEES			
8. APP CODE		11. AS OF DATE See section 16	13. DATE OF next SUBMISSIONS See section 16	A. ADDRESS		B. COPIES	
16. REMARKS <u>Timelines:</u> <ul style="list-style-type: none"> The proposed MPS will be reviewed during the kick-off meeting. The Contractor shall finalize and submit the MPS at least ten (10) working days before the kick-off meeting. Response Time: Canada will provide comments on the MPS within ten (10) working days of receipt. The Contractor shall update and re-submit the MPS on a monthly basis and after each milestone change. 							
				DND PM		1	1
PREPARED BY XXX				APPROVED BY PM			
DATE				DATE			
17. CONTRACT FILE/DOC NUMBER		18. ESTIMATED NO OF PAGES		19. ESTIMATED PRICE		15. TOTAL	
						1	1
						1	1

Appendix 6 to Annex A

Data Item Descriptions (DIDs)

LEOPARD 1C2 TANK CONVERSION TO TARGET

Requisition Number:
DND Document # W8486-217668/A

Date: 20-11-2020

RDIMS #

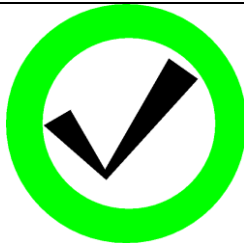

NOTICE

This documentation has been reviewed by the technical authority and does not contain controlled goods.

AVIS

Cette documentation a été révisée par l'autorité technique et ne contient pas de marchandises contrôlées.

Prepared by:
National Defence Headquarters
Major General George R. Pearkes Building
Ottawa, Ontario
K1A 0K2

LIST OF CDRLs and DIDs

CDRL	DID	Title	Short title
101	PM-001	Project Management Plan	PMP
102	PM-002	Work Breakdown Structure	WBS
103	PM-003	Master Project Schedule	MPS

DATA ITEM DESCRIPTION		DND Form 1409
1. TITLE Program Management Plan (PMP)		2. IDENTIFICATION NUMBER PM-001
3. DESCRIPTION The PMP describes the Contractor's processes and organization to carry the activities necessary to complete the Work within the schedule and costs proposed, while meeting all contractual requirements.		
4. APPROVAL DATE	5. OFFICE OF PRIMARY INTEREST DND PM	6. GIDEP APPLICABLE N/A
7. APPLICATION / INTERRELATIONSHIP CDRL 101		
8. ORIGINATOR XXX		9. APPLICABLE FORMS
10. PREPARATION INSTRUCTIONS 10.1 <u>FORMAT</u> 10.1.1 The PMP may be in the Contractor's format. 10.1.2 It should be concise, simple and direct. 10.2 <u>CONTENT</u> 10.2.1 The PMP shall describe the Contractor's plan for organizing, staffing, controlling and directing all of Project activities, including Subcontractor activities, necessary to deliver compliant Systems, Engineering Drawings, Integrated Logistics Support, and Contract Data Requirements within schedule, resource and budgetary constraints. 10.2.2 The following items shall be addressed: 10.2.2.1 Overview: a) Purpose, Background, Scope and Objectives; b) Assumptions, Constraints and Risks; c) Program Deliverables; d) Organization Summary; and e) Schedule Summary. 10.2.2.2 Organization: a) Program Management Organizational Chart, including internal and external organizations as it pertains to this Contract; b) Roles and Responsibilities, including internal and external organizations; and c) Escalating Lines of Communications. 10.2.2.3 Management Processes (list of options but please include those applicable): a) Project Management Approach and Procedures; b) Sub-Contractor Management; c) Schedule Control;		

- d) Resource Allocation;
- e) Budget Control;
- f) Quality Assurance;
- g) Performance Monitoring;
- h) Reporting;
- i) Communications;
- j) Problem Resolution;
- k) Project Work Tasks/Elements Closing;
- l) Process Improvement;
- m) Risk Identification and Management;
- n) Environmental, Health and Safety Issues Management;
- o) Information Management (IM);
- p) Change Control Processes; and
- q) Production Management, Procurement and Subcontract Management

10.2.3 The PMP shall include disaster recovery for all program data.

10.2.4 The PMP shall describe the Contractor's program management organisation and discuss their interfaces with and access to corporate senior management, other necessary corporate resources, and each other. The PMP shall also include organisation charts illustrating these relationships.

DATA ITEM DESCRIPTION		
1. TITLE Work Breakdown Structure (WBS)		2. IDENTIFICATION NUMBER PM 002
3. DESCRIPTION The CWBS comprises of a complete hierarchical representation of the goods, services and other tasks to be performed during the Program. It forms the framework for planning, management and status reporting and for estimating costs, schedule, risk, and Program performance assessments.		
4. APPROVAL DATE	5. OFFICE OF PRIMARY INTEREST DND PM	6. ORIGINATOR XXX
7. APPLICATION / INTERRELATIONSHIP CDRL 102		8. APPLICABLE FORMS
9. PREPARATION INSTRUCTIONS 9.1. The contractor must prepare a CWBS that reflects the entire scope of the Program. 9.2. The Contractor must propose the CWBS format for approval by DND. 9.3. The CWBS must comprise of a Work Breakdown Structure (WBS) index, a WBS graphic, and a WBS dictionary. 9.4. Every record of the WBS index must include the following information: a. WBS element number; b. WBS element title; c. WBS element revision date and revision number; d. Cross references to the conditions of contract and Statement of Work; and e. Any other information required of the WBS index by the Contractor. 9.5. The CWBS must show the complete hierarchical breakdown, including the element and sub-element descriptions and codes, down to the lowest product end item deliverable. The descriptions must be indented to indicate the CWBS level for each element. Where applicable, RFP paragraph numbers and any other identifiers such as article numbers, specification numbers and Program end item numbers must also be shown.		

DATA ITEM DESCRIPTION		
9. TITLE Program Master Schedule (MPS)	10. IDENTIFICATION NUMBER PM 003	
11. DESCRIPTION Program schedule management includes the processes required to manage the timely completion of the Program of which the Program Master Schedule presents linked activities with planned dates, durations, milestones, and resources.		
12. APPROVAL DATE	13. OFFICE OF PRIMARY INTEREST DND PM	14. ORIGINATOR XXX
15. APPLICATION / INTERRELATIONSHIP CDRL 103		16. APPLICABLE FORMS
<p>9. PREPARATION INSTRUCTIONS</p> <p>9.1. The contractor must prepare the Program Master Schedule.</p> <p>9.2. The Contractor must propose the Program Master Schedule format for approval by DND.</p> <p>9.3. The requirements of the Program Master Schedule are as follows:</p> <ul style="list-style-type: none"> a. A Gantt Chart; b. Identification of the critical path; c. The baseline schedule must be retained for each work activity, event and milestone along with the start/finish dates and total duration, for comparison to a current schedule; and d. The current schedule must be shown for each work activity, event and milestone along with the start/finish dates and total duration. <p>9.4. The Contractor must include any sub-plans that break down the activities below those listed in the Master Schedule.</p> <p>9.5. The Contractor must provide a monthly schedule progress update including.</p> <ul style="list-style-type: none"> a. A line extending from the appropriate point of the time scale showing the "as of date" ; and b. Progress indications and planned or actual schedule slippage/accelerations of the current schedule clearly shown in relation to the baseline schedule. 		

ANNEX “B”

BASIS OF PAYMENT

Item No	Conversion	Origin	Quantity	Unit Price*
1	Leopard 1C2 MBTs NSN: 2350-21-920-4873	7 Canadian Forces Supply Depot (CFSD) Edmonton, Alberta	22	\$ _____
2	Leopard 1C2 MBTs NSN: 2350-21-920-4873	Army Equipment Fielding Centre (AEFC) Montreal, Québec	21	\$ _____
3	(OPTION) Leopard 1C2 MBTs NSN: 2350-21-920-4873	Army Equipment Fielding Centre (AEFC) Montreal, Québec	6	\$ _____

Item No. 1: This Unit Price is inclusive of all costs for the Conversion work as described in Annex A, including pickup and delivery transportation, training, and any required associated meetings and deliverables. This includes the price of sending technicians to 202 Workshop if this method to perform the work is used. The Contractor will not be paid any additional fee or reimbursed for costs above the Unit Price.

Item No. 2: This Unit Price is inclusive of all costs for the Conversion work as described in Annex A, including delivery transportation, training, and any required associated meetings and deliverables. This includes the price of sending technicians to 202 Workshop if this method to perform the work is used. If the Contractor is conducting the work at their facility, shipment to their location will coordinated and paid for by Canada. The Contractor will not be paid any additional fee or reimbursed for costs above the Unit Price. The quantity of this item may vary in accordance with the paragraph 4.1.1 of the Annex A – Statement of Work.

Item No. 3: This Unit Price for the Optional qty 6 is inclusive of all costs for the Conversion work as described in Annex A, including delivery transportation, training, and any required associated meetings and deliverables. This includes the price of sending technicians to 202 Workshop if this method to perform the work is used. If the Contractor is conducting the work at their facility, shipment to their location will coordinated and paid for by Canada. The Contractor will not be paid any additional fee or reimbursed for costs above the Unit Price. The quantity of this item may vary in accordance with the paragraph 4.1.1 of the Annex A – Statement of Work.

ANNEX "C"

ELECTRONIC PAYMENT INSTRUMENTS

The Bidder accepts any of the following Electronic Payment Instrument(s):

- Direct Deposit (Domestic and International);
- Electronic Data Interchange (EDI);
- Wire Transfer (International Only);

ANNEX "D"

FEDERAL CONTRACTORS PROGRAM FOR EMPLOYMENT EQUITY - CERTIFICATION

I, the Bidder, by submitting the present information to the Contracting Authority, certify that the information provided is true as of the date indicated below. The certifications provided to Canada are subject to verification at all times. I understand that Canada will declare a bid non-responsive, or will declare a contractor in default, if a certification is found to be untrue, whether during the bid evaluation period or during the contract period. Canada will have the right to ask for additional information to verify the Bidder's certifications. Failure to comply with any request or requirement imposed by Canada may render the bid non-responsive or constitute a default under the Contract.

For further information on the Federal Contractors Program for Employment Equity visit [Employment and Social Development Canada \(ESDC\)-Labour's](#) website.

Date: _____ (YYYY/MM/DD) (If left blank, the date will be deemed to be the bid solicitation closing date.)

Complete both A and B.

A. Check only one of the following:

- A1. The Bidder certifies having no work force in Canada.
- A2. The Bidder certifies being a public sector employer.
- A3. The Bidder certifies being a [federally regulated employer](#) being subject to the [Employment Equity Act](#).
- A4. The Bidder certifies having a combined work force in Canada of less than 100 employees (combined work force includes: permanent full-time, permanent part-time and temporary employees [temporary employees only includes those who have worked 12 weeks or more during a calendar year and who are not full-time students]).
- A5. The Bidder has a combined workforce in Canada of 100 or more employees; and
 - A5.1. The Bidder certifies already having a valid and current [Agreement to Implement Employment Equity](#) (AIEE) in place with ESDC-Labour.

OR

- A5.2. The Bidder certifies having submitted the [Agreement to Implement Employment Equity](#) (LAB1168) to ESDC-Labour. As this is a condition to contract award, proceed to completing the form Agreement to Implement Employment Equity (LAB1168), duly signing it, and transmit it to ESDC-Labour.

B. Check only one of the following:

- B1. The Bidder is not a Joint Venture.

OR

- B2. The Bidder is a Joint Venture and each member of the Joint Venture must provide the Contracting Authority with a completed annex Federal Contractors Program for Employment Equity - Certification. (Refer to the Joint Venture section of the Standard Instructions)