



A1. CONTRACT ADVISOR

Ms. Meghan Andrews
 Contract Advisor
 Real Property – Projects
 Mission Procurement (AAO)
 Email: *(see below)*
 realproperty-contracts@international.gc.ca
 Telephone: +1 613 290 7847

Construction

Request for Proposals (RFP)

for

Performance of the work as described in Appendix “A” – Statement of Work.

A2. TITLE Restoration of the Official Residence at the Embassy of Canada to Norway in Oslo		
A3. SOLICITATION NUMBER 21-183221	A4. PROJECT NUMBER Not Applicable.	A5. DATE 22 June, 2021
A6. RFP DOCUMENTS 1. Request for Proposals (RFP) title page 2. Submission Requirements (Section “I”) 3. Evaluation and Basis of Selection (Section “II”) 4. Tender Form (Section “III”) 5. General Instructions (Section “IV”) 6. Draft Construction Contract 7. Statement of Work (Appendix “A”) 8. Drawings and Specifications 9. Photographs 10. Security Requirements Check List In the event of discrepancies, inconsistencies or ambiguities of the wording of these documents, the document that appears first on the above list shall prevail.		
A7. PROPOSAL DELIVERY In order for the proposal to be valid, it must be received no later than 14h00 (Eastern Daylight Time) on Monday, 09 July 2021 referred to herein as the “Closing Date”. Electronic proposals must be sent only to the following email address: realproperty-contracts@international.gc.ca		
A8. TENDER FORM All the information required in section 2.4 must appear in Section “III” – Tender Form ONLY and must be included in a separate attachment named “Tender Form”. Failure to comply may result in the proposal being declared non-compliant and rejected from further consideration.		
A9. PROPONENTS’ CONFERENCE A Proponents’ conference will be held virtually on Friday, 25 June, 2021 . The conference will begin at TBD (local time in Oslo, Norway) . The purpose of the proponents’ conference is to provide instructions and assistance to the Proponents in preparing the documentation required for the proposal. The scope of the requirement outlined in the bid solicitation will be reviewed during the conference and questions will be answered. It is recommended that Proponents who intend to submit a proposal attend or send a representative. Proponents are requested to communicate with the Contract Advisor no later than three (3) calendar days prior to confirm attendance and provide the name(s) of the person(s) who will attend. Proponents who do not attend or do not send a representative will not be given an alternative appointment but they will not be precluded from submitting a bid. Any clarifications or changes to the bid solicitation resulting from the proponents’ conference will be included as an amendment to the bid solicitation.		
A10. ENQUIRIES All enquiries or issues concerning this RFP must be submitted in writing to the Contract Advisor no later than three (3) calendar days prior to the Closing Date and Time in order to allow sufficient time to provide a response.		
A11. LANGUAGE Proposals shall be submitted in English or French only.		
A12. CONTRACT DOCUMENTS The draft contract which the selected Proponent will be expected to execute is included with this RFP. Proponents are advised to review it in detail and identify any problematic clauses to the Contract Advisor in accordance with A10 - Enquiries. Her Majesty reserves the right not to make any amendment(s) to the Contract Documents.		

SECTION “I” – SUBMISSION REQUIREMENTS**1.0 SUBMISSION OF PROPOSAL**

- 1.1 Proposals must be received by DFATD at the email address identified and by the date and time specified on page 1 of the solicitation.
- 1.2 Proponents should ensure that their name and the solicitation number is clearly referenced in the email subject line. It is the responsibility of the Proponent to confirm that their submission has been received on time and to the correct email address.
- 1.3 More than one (1) e-mail can be sent if necessary. If the same file is sent twice, the latest file received will be used for evaluation purposes and the previous one(s) will not be opened.
- 1.4 Her Majesty requests that Proponents provide their electronic proposals in Portable Document Format (.pdf) software application files or Microsoft office version 2003 or greater files.
- 1.5 Proponents should follow the specifications format instructions described below, during the preparation of their proposal:
 - Minimum type face of 10 points.
 - All material be formatted to print on 8.5” x 11” or A4 paper.
 - For clarity and comparative evaluation, the Proponent should respond using the same subject headings and numbering structure as in this RFP document.
- 1.6 Proposals may be modified or resubmitted only before the solicitation Closing Date and Time, and must be done in writing. The latest proposal received will supersede any previously received proposals.
- 1.7 Her Majesty will take no responsibility if a proposal is not received on time because the e-mail was refused by a server for the following reasons:
 - The size of attachments exceeds 10 MB.
 - The e-mail was rejected or put in quarantine because it contains executable code (including macros).
 - The e-mail was rejected or put in quarantine because it contains files that are not accepted by DFATD server, such as, but not limited to, .rar, encrypted .zip, encrypted .pdf, .exe., etc.
- 1.8 Links to an online storage service (such as Google Drive™, Dropbox™, etc.) or to another website, a File Transfer Protocol (FTP) service access, or any other means of transferring files, will not be accepted. All documents submitted must be attached to the e-mail.
- 1.9 It is strongly recommended that Proponents confirm with the Contract Advisor that their complete proposal was received. For this same reason, it is recommended that in cases where more than one e-mail containing documents comprising the quote is submitted, the emails be numbered and the total number of emails sent in response to the solicitation also be identified.
- 1.10 Her Majesty requires that each proposal, at Closing Date and Time or upon request from the Contract Advisor, be signed by the Proponent or by an authorized representative of the Proponent. If any required signature(s) are not submitted as requested, the Contract Advisor may inform the Proponent of a time frame within which to provide the signature(s). Failure to comply with the request of the Contract Advisor and to provide the signature(s) within the time frame provided may render the proposal non-responsive.

- 1.11** It is the Proponent's responsibility to:
- obtain clarification of the requirements contained in the RFP, if necessary, before submitting a proposal;
 - prepare its proposal in accordance with the instructions contained in the RFP;
 - submit by Closing Date and Time a complete proposal;
 - send its proposal only to the email address specified on page 1 of the bid solicitation;
 - ensure that the Proponent's name, and the solicitation number are in the subject line of the email containing the proposal; and,
 - provide a comprehensible and sufficiently detailed proposal, including all requested pricing details, that will permit a complete evaluation in accordance with the criteria set out in the RFP.
- 1.12** Unless specified otherwise in the RFP, Her Majesty will evaluate only the documentation provided with a Proponent's proposal. Her Majesty will not evaluate information such as references to Web site addresses where additional information can be found, or technical manuals or brochures not submitted with the proposal.
- 1.13** A proposal cannot be assigned or transferred in whole or in part.
- 1.14 Approval of alternative Material**

The proposal must be based on using materials specified by trade or manufacturer's names where specified in the tender documentation.

Alternatives to materials and equipment specified by trade or manufacturer's names will be considered during the bid period if full descriptive data on proposed alternatives is submitted in writing to the Contract Advisor as specified in A10. Enquiries.

The Contract Advisor must approve any alternative material in writing. Approved alternatives will be incorporated in the specification by issuance of addenda to the tender documents.

SECTION "II" – EVALUATION AND BASIS OF SELECTION

2.0 TECHNICAL PROPOSAL

- 2.1 The evaluation will be based solely on the content of the responses and any correctly submitted amendment. No assumptions should be made that Her Majesty has any previous knowledge of the Proponents' qualifications other than that supplied pursuant to this RFP.
- 2.2 The Proponent's Technical response **must not** exceed thirty (30) single-sided pages of 8½ "x 11" paper, minimum type face 10 pts., including organization charts and schedule. Material exceeding the thirty (30) page maximum will **NOT** be considered.

2.3 TECHNICAL EVALUATION

2.3.1 MANDATORY REQUIREMENTS

Failure to comply with any of the mandatory requirements will render the Proposal non-compliant and the Proposal will receive no further consideration.

SECTION 1 – PROPONENT EXPERIENCE

CORPORATE		
Item	DESCRIPTION	COMPLIANCE
M1	Proponent must have a minimum of five (5) years' experience in restoration and/ or renovation of residential and/or commercial buildings, in the past ten (10) years to bid closing date.	Proponent must provide the following: <ul style="list-style-type: none"> • a summary of their experience; • demonstration of 5+ years' experience; and • demonstration that experience is gained within the last ten (10) years.
M2	Proponent must possess accredited Norwegian construction membership to one of the registered associations. Acceptable registered associations and their respective websites are: 1. The Federation of Norwegian Construction Industries (BNL) ○ https://www.bnl.no/in-english/ 2. ByggMesterforbundet ○ https://www.byggmesterforbundet.no/ 3. Norwegian Green Building Council ○ https://www.worldgbc.org/member-directory/norwegian-green-building-council 4. Norwegian Building Authority. ○ https://www.regjeringen.no/	Proponent must provide a copy of their classification licence and/or proof of membership obtained from one of the listed registered associations.

SECTION 2 – PERSONNEL EXPERIENCE

PROJECT MANAGER		
Item	DESCRIPTION	COMPLIANCE

M3	The proposed Site Manager must have a minimum of five (5) years' experience as a site manager in restoration and/or renovation projects for residential and/or commercial properties in the past ten (10) years to bid closing date.	Proponent should provide the following: <ul style="list-style-type: none"> • summary of the Project Manager's experience; • demonstration of 5+ years' experience; and • demonstration that experience is within the last 10 years.
-----------	--	--

2.3.2 POINT-RATED CRITERIA (MAXIMUM TOTAL OF 62 POINTS)

2.3.2.1 Work Plan (20 points)

Intent: Evaluate the Proponent's strategy for delivering the Project.

Information to be submitted:

- 1) the name and role of key Proponent team members (ex – Site Manager, foreman, leads for masonry, window works, etc.) for each category of the works;
- 2) a project organization chart showing names and titles of all Proponent team resources named for the Project; and
- 3) a short description of the roles of key stake-holders: Proponent Team, sub-consultants and other specialists and describe how this team will work together to execute the various phases of the Work.

Rating:

Score	Evaluation	Definition
20	Outstanding	Innovative, comprehensive and complete in all details; exceeds all requirements and objectives.
15	Excellent	Substantial response in clearly definable detail; meets all critical requirements; demonstrates full understanding.
10	Good	Meets all minimum requirements; demonstrates partial understanding.
5	Poor	Misses some requirements, demonstrates partial understanding; some detail missing.
0	Unsatisfactory	No data/incomplete bid; lacks understanding.

2.3.2.2 Corporate Experience (10 points per project. Total of 30 points)

Intent: Evaluate the Proponent's recent corporate experience on projects of similar size and scope as described in the Statement of Work.

"Recent" is defined as work in the past five (5) years to bid closing date.

"Similar" is defined as property restorations and/or renovations including works such as replacement of windows, exterior cladding, major refurbishments, landscape works, or garage construction.

Information to be submitted:

Proponent must submit **three (3)** recent projects of similar size and scope. Each project must have included coordination with occupants to maintain the system operation with the occupants remaining in the building and continuing with their office functions.

- 1) The following should be provided for each project:
 - Title of project;
 - Client name;
 - Year property was built;
 - Brief description of project scope;
 - Description of restoration and/ or renovation* services provided;
 - Work period;
 - Start date of work (month, year)
 - End date of work (month, year)
 - Corporate role in the project;
 - Description of coordination with occupants.

Rating:

Score	Evaluation	Definition
7	Outstanding	Innovative, comprehensive and complete in all details; exceeds all requirements and objectives.
5	Excellent	Substantial response in clearly definable detail; meets all critical requirements; demonstrates full understanding.
3	Good	Meets all minimum requirements; demonstrates partial understanding.
1	Poor	Misses some requirements, demonstrates partial understanding; some detail missing.
0	Unsatisfactory	No data/incomplete bid; lacks understanding.

- 2) For each project, Proponent should identify the location (city, country) where the work took place, as well as the year the building/structure being worked on was built.

Work located in Norway – **1 points per project**

Work done on a building constructed in or prior to 1950 – **2 points per project**

2.3.2.3 Experience of Site Manager (4 points per project. Total of 12 points)

Intent: Evaluate the recent site management experience of the proposed Site Manager on projects of similar size and scope as described in the Statement of Work.

“Recent” is defined as work in the past five (5) years to bid closing date.

“Similar” is defined as property restorations and/or renovations including works such as replacement of windows, exterior cladding, major refurbishments, landscape works, or garage construction.

Information to be submitted:

- 1) The Site Manager should submit **three (3)** recent projects of similar size and scope that they have been the site manager on. The following should be provided for each project:
 - Title of project
 - Location of project (city, country)
 - Client name
 - Brief description of project scope
 - Work period
 - Start date of work (month, year)
 - End date of work (month, year)
 - Description of services provided by Site Manager

Rating:

Score	Evaluation	Definition
4	Outstanding	Innovative, comprehensive and complete in all details; exceeds all requirements and objectives.
3	Excellent	Substantial response in clearly definable detail; meets all critical requirements; demonstrates full understanding.
2	Good	Meets all minimum requirements; demonstrates partial understanding.
1	Poor	Misses some requirements, demonstrates partial understanding; some detail missing.
0	Unsatisfactory	No data/incomplete bid; lacks understanding.

2.4 TENDER FORM

2.4.1 All the information required in section 2.4 must appear on Section “III” – Tender Form and ONLY and must be included in a separate attachment named “Tender Form”. Failure to comply may result in the proposal being declared non-compliant and rejected from further consideration.

2.4.2 Firm Price

2.4.2.1 Proponents shall quote an all inclusive Firm Price (excluding the cost of The Minister’s services and equipment\ furniture) on the form attached as Section “IV” – Tender Form. The Firm Price must include, but not necessarily be limited to, all costs resulting from the performance of the Work as described in this RFP, all costs resulting from the performance of any additional Work described in the Proponent’s Proposal (unless clearly described as an option), all travel, living costs and all overhead costs including disbursements;

2.4.2.2 Proponents shall estimate the value of the taxes (including VAT as per 2.4.3) expected to be payable by Her Majesty as a result of entering into a contract with the Proponent on the Tender Form;

- 2.4.2.3 All payments shall be made according to the terms of payment set out in the attached draft contract;
- 2.4.2.4 Exchange rate fluctuation protection is not offered; and
- 2.4.2.5 Tender Forms not meeting the above requirements may not be given any further consideration.

2.4.3 Taxes & Duties

- 2.4.3.1 Proponents are to provide full details concerning the applicability, amount and administration of the payment of all taxes (including VAT as described below) and duties (including import duties) payable in respect of the Work, as well as any possible exemption from all or part of same.
- 2.4.3.2 Her Majesty will pay the VAT specified in the Tender Form provided:
 - 2.5.3.2.1 that amount is applicable to the Work provided by the Contractor to Her Majesty under the Contract. Her Majesty will not be responsible for the payment of any VAT payable by the Contractor to any third party (including Subcontractors);
 - 2.5.3.2.2 Her Majesty is unable to procure an exemption from VAT in respect of the Work;
 - 2.5.3.2.3 the Contractor agrees to
 - 2.5.3.2.4 render every reasonable assistance to Her Majesty in obtaining reimbursement of all VAT paid in respect of the Work from the appropriate Government Agency;
 - 2.5.3.2.5 the VAT is shown separately on all of the Contractor's invoices and progress claims; and
 - 2.5.3.2.6 the Contractor agrees to remit to the appropriate Government Agency any amounts of VAT legally required to be remitted by the Contractor pursuant to applicable tax laws.

2.4.4 Price Breakdown

Her Majesty reserves the right to request a breakdown of the components of the Tender Form should it believe that the price is unreasonable. Failure to provide an adequate breakdown, describing the rationale and assumptions used to determine the cost of each component of the Work, may lead to disqualification.

2.5 BASIS OF SELECTION

- 2.5.1 To be declared responsive, a bid must:
 - a. comply with all the requirements of the bid solicitation; and
 - b. meet all mandatory criteria.
- 2.5.2 Bids not meeting (a) or (b) will be declared non-responsive.
- 2.5.3 The selection will be based on the highest responsive combined rating of technical merit and price. The ratio will be 60 % for the technical merit and 40 % for the price.
- 2.5.4 To establish the technical merit score, the overall technical score for each responsive bid will be determined as follows: total number of points obtained / maximum number of points available multiplied by the ratio of 60 %.
- 2.5.5 To establish the pricing score, each responsive bid will be prorated against the lowest evaluated price and the ratio of 40 %.
- 2.5.6 For each responsive bid, the technical merit score and the pricing score will be added to determine its combined rating.

2.5.7 In the case of a tie for the highest total score, the Proponent submitting the lowest price will be selected. In the case of a tie for the total score and a tie for the price proposal score, the Proponent with the highest score for the "Technical Proposal" will be selected.

2.5.8 Neither the responsive bid obtaining the highest technical score nor the one with the lowest evaluated price will necessarily be accepted. The responsive bid with the highest combined rating of technical merit and price will be recommended for award of a contract.

The table below illustrates an example where all three bids are responsive and the selection of the Contractor is determined by a 60/40 ratio of technical merit and price, respectively. The total available points equals 135 and the lowest evaluated price is \$45,000 (45).

Basis of Selection - Highest Combined Rating Technical Merit (60%) and Price (40%)

		Proponent 1	Proponent 2	Proponent 3
Overall Technical Score		115/135	89/135	92/135
Bid Evaluated Price		\$55,000.00	\$50,000.00	\$45,000.00
Calculations	Technical Merit Score	$115/135 \times 60 = 51.11$	$89/135 \times 60 = 39.56$	$92/135 \times 60 = 40.89$
	Pricing Score	$45/55 \times 40 = 32.73$	$45/50 \times 40 = 36.00$	$45/45 \times 40 = 40.00$
Combined Rating		83.84	75.56	80.89
Overall Rating		1st	3rd	2nd

2.6 PHASED BID COMPLIANCE PROCESS (PBCP)

2.6.1 General

- (a) Her Majesty is conducting the PBCP described below for this requirement.
- (b) Notwithstanding any review by Her Majesty at Phase I or II of the PBCP, Proponents are and will remain solely responsible for the accuracy, consistency and completeness of their Bids and Her Majesty does not undertake, by reason of this review, any obligations or responsibility for identifying any or all errors or omissions in Bids or in responses by a Proponent to any communication from Her Majesty.

The Proponent acknowledges that the reviews in Phase I and II of this PBCP are preliminary and do not preclude a finding in Phase III that the bid is non-responsive, even for mandatory requirements which were subject to review in Phase I or II and notwithstanding that the bid had been found responsive in such earlier phase. Her Majesty may deem a bid to be non-responsive to a mandatory requirement at any phase.

The Proponent also acknowledges that its response to a notice or a Compliance Assessment Report (CAR) (each defined below) in Phase I or II may not be successful in rendering its bid responsive to the mandatory requirements that are the subject of the notice or CAR, and may render its bid non-responsive to other mandatory requirements.

- (c) Her Majesty may, in its discretion, request and accept at any time from a Proponent and consider as part of the Bid, any information to correct errors or deficiencies in the Bid that are clerical or administrative, such as, without limitation, failure to sign the Bid or any part or to checkmark a box in a form, or other failure of format or form or failure to acknowledge; failure to provide a

procurement business number or contact information such as names, addresses and telephone numbers; inadvertent errors in numbers or calculations that do not change the amount the Proponent has specified as the price or of any component thereof that is subject to evaluation. This shall not limit Her Majesty’s right to request or accept any information after the bid solicitation closing in circumstances where the bid solicitation expressly provides for this right. The Proponent will have the time period specified in writing by Her Majesty to provide the necessary documentation. Failure to meet this deadline will result in the Bid being declared non-responsive.

- (d) The PBCP does not limit Her Majesty’s rights to request or accept any information during the solicitation period or after bid solicitation closing in circumstances where the bid solicitation expressly provides for this right, or in the circumstances described in subsection (c).
- (e) Her Majesty will send any Notice or CAR by any method Her Majesty chooses, in its absolute discretion. The Proponent must submit its response by the method stipulated in the Notice or CAR. Responses are deemed to be received by Her Majesty at the date and time they are delivered to Her Majesty by the method and at the address specified in the Notice or CAR. An email response permitted by the Notice or CAR is deemed received by Her Majesty on the date and time it is received in Her Majesty’s email inbox at Her Majesty’s email address specified in the Notice or CAR. A Notice or CAR sent by Her Majesty to the Proponent at any address provided by the Proponent in or pursuant to the Bid is deemed received by the Proponent on the date it is sent by Her Majesty. Her Majesty is not responsible for late receipt by Her Majesty of a response, however caused.

2.6.2 Phase I: Financial Bid

- (a) After the closing date and time of this bid solicitation, Her Majesty will examine the Bid to determine whether it includes a Financial Bid and whether any Financial Bid includes all information required by the solicitation. Her Majesty’s review in Phase I will be limited to identifying whether any information that is required under the bid solicitation to be included in the Financial Bid is missing from the Financial Bid. This review will not assess whether the Financial Bid meets any standard or is responsive to all solicitation requirements.
- (b) Her Majesty’s review in Phase I will be performed by officials of the Department of Foreign Affairs, Trade and Development Canada.
- (c) If Her Majesty determines, in its absolute discretion that there is no Financial Bid or that the Financial Bid is missing all of the information required by the bid solicitation to be included in the Financial Bid, then the Bid will be considered non-responsive and will be given no further consideration.
- (d) For Bids other than those described in c), Her Majesty will send a written notice to the Proponent (“Notice”) identifying where the Financial Bid is missing information. A Proponent, whose Financial Bid has been found responsive to the requirements that are reviewed at Phase I, will not receive a Notice. Such Proponents shall not be entitled to submit any additional information in respect of their Financial Bid.
- (e) The Proponents who have been sent a Notice shall have the time period specified in the Notice (the “Remedy Period”) to remedy the matters identified in the Notice by providing to Her Majesty, in writing, additional information or clarification in response to the Notice. Responses received after the end of the Remedy Period will not be considered by Her Majesty, except in circumstances and on terms expressly provided for in the Notice.

- (f) In its response to the Notice, the Proponent will be entitled to remedy only that part of its Financial Bid which is identified in the Notice. For instance, where the Notice states that a required line item has been left blank, only the missing information may be added to the Financial Bid, except that, in those instances where the addition of such information will necessarily result in a change to other calculations previously submitted in its Financial Bid, (for example, the calculation to determine a total price), such necessary adjustments shall be identified by the Proponent and only these adjustments shall be made. All submitted information must comply with the requirements of this solicitation.
- (g) Any other changes to the Financial Bid submitted by the Proponent will be considered to be new information and will be disregarded. There will be no change permitted to any other Section of the Proponent’s Bid. Information submitted in accordance with the requirements of this solicitation in response to the Notice will replace, in full, only that part of the original Financial Bid as is permitted above, and will be used for the remainder of the bid evaluation process.
- (h) Her Majesty will determine whether the Financial Bid is responsive to the requirements reviewed at Phase I, considering such additional information or clarification as may have been provided by the Proponent in accordance with this Section. If the Financial Bid is not found responsive for the requirements reviewed at Phase I to the satisfaction of Her Majesty, then the Bid shall be considered non-responsive and will receive no further consideration.
- (i) Only Bids found responsive to the requirements reviewed in Phase I to the satisfaction of Her Majesty, will receive a Phase II review.

2.6.3 Phase II: Technical Bid

- (a) Her Majesty’s review at Phase II will be limited to a review of the Technical Bid to identify any instances where the Proponent has failed to meet any Eligible Mandatory Criterion. This review will not assess whether the Technical Bid meets any standard or is responsive to all solicitation requirements. Eligible Mandatory Criteria are all mandatory technical criteria that are identified in this solicitation as being subject to the PBCP. Mandatory technical criteria that are not identified in the solicitation as being subject to the PBCP, will not be evaluated until Phase III.
- (b) Her Majesty will send a written notice to the Proponent (Compliance Assessment Report or “CAR”) identifying any Eligible Mandatory Criteria that the Bid has failed to meet. A Proponent whose Bid has been found responsive to the requirements that are reviewed at Phase II will receive a CAR that states that its Bid has been found responsive to the requirements reviewed at Phase II. Such Proponent shall not be entitled to submit any response to the CAR.
- (c) A Proponent shall have the period specified in the CAR (the “Remedy Period”) to remedy the failure to meet any Eligible Mandatory Criterion identified in the CAR by providing to Her Majesty in writing additional or different information or clarification in response to the CAR. Responses received after the end of the Remedy Period will not be considered by Her Majesty, except in circumstances and on terms expressly provided for in the CAR.
- (d) The Proponent’s response must address only the Eligible Mandatory Criteria listed in the CAR as not having been achieved, and must include only such information as is necessary to achieve such compliance. Any additional information provided by the Proponent which is not necessary to achieve such compliance will not be considered by Her Majesty, except that, in those instances where such a response to the Eligible Mandatory Criteria specified in the CAR will necessarily result in a consequential change to other parts of the Bid, the Proponent shall identify such additional changes, provided that its response must not include any change to the Financial Bid.

- (e) The Proponent’s response to the CAR should identify in each case the Eligible Mandatory Criterion in the CAR to which it is responding, including identifying in the corresponding section of the original Bid, the wording of the proposed change to that section, and the wording and location in the Bid of any other consequential changes that necessarily result from such change. In respect of any such consequential change, the Proponent must include a rationale explaining why such consequential change is a necessary result of the change proposed to meet the Eligible Mandatory Criterion. It is not up to Her Majesty to revise the Proponent’s Bid, and failure of the Proponent to do so in accordance with this subparagraph is at the Proponent’s own risk. All submitted information must comply with the requirements of this solicitation.
- (f) Any changes to the Bid submitted by the Proponent other than as permitted in this solicitation, will be considered to be new information and will be disregarded. Information submitted in accordance with the requirements of this solicitation in response to the CAR will replace, in full, only that part of the original Bid as is permitted in this Section.
- (g) Additional or different information submitted during Phase II permitted by this section will be considered as included in the Bid, but will be considered by Her Majesty in the evaluation of the Bid at Phase II only for the purpose of determining whether the Bid meets the Eligible Mandatory Criteria. It will not be used at any Phase of the evaluation to increase or decrease any score that the original Bid would achieve without the benefit of such additional or different information. For instance, an Eligible Mandatory Criterion that requires a mandatory minimum number of points to achieve compliance will be assessed at Phase II to determine whether such mandatory minimum score would be achieved with such additional or different information submitted by the Proponent in response to the CAR. If so, the Bid will be considered responsive in respect of such Eligible Mandatory Criterion, and the additional or different information submitted by the Proponent shall bind the Proponent as part of its Bid, but the Proponent’s original score, which was less than the mandatory minimum for such Eligible Mandatory Criterion, will not change, and it will be that original score that is used to calculate any score for the Bid
- (h) Her Majesty will determine whether the Bid is responsive for the requirements reviewed at Phase II, considering such additional or different information or clarification as may have been provided by the Proponent in accordance with this Section. If the Bid is not found responsive for the requirements reviewed at Phase II to the satisfaction of Her Majesty, then the Bid shall be considered non-responsive and will receive no further consideration.
- (i) Only Bids found responsive to the requirements reviewed in Phase II to the satisfaction of Her Majesty, will receive a Phase III evaluation.

2.6.4 Phase III: Final Evaluation of the Bid

- (a) In Phase III, Her Majesty will complete the evaluation of all Bids found responsive to the requirements reviewed at Phase II. Bids will be assessed in accordance with the entire requirement of the bid solicitation including the technical and financial evaluation criteria.
- (b) A Bid is non-responsive and will receive no further consideration if it does not meet all mandatory evaluation criteria of the solicitation.

2.6.5 Technical Evaluation

2.6.5.1 The Phased Bid Compliance Process will apply to all mandatory technical criteria.

SECTION "III" – TENDER FORM

CONTACT INFORMATION

Name of Firm: _____

Address: _____

Contact Person: _____

Phone number: (____) ____-____ Fax number: (____) ____-____

Email: _____

The FIRM PRICE (*exclusive of VAT*) will be used for evaluation purposes.

TF1 FIRM PRICE

Firm Price (*exclusive of VAT*): _____
(in accordance with 2.4.2)

Applicable taxes: _____
(in accordance with 2.4.3)

Total Price: _____
(Firm Price + Applicable Taxes)

All amounts are in Norwegian Krone (Kr).

Signature

Date

Print Name and Capacity

TF3 ACCEPTANCE AND ENTRY INTO CONTRACT

I/We undertake, within fourteen (14) calendar days of receipt of notification of acceptance of my/our bid, to sign a contract contained in the RFP incorporating all the relative elements of this project, for the performance of the Work provided I/We are notified, by Her Majesty, of the acceptance of my/our bid within one hundred and twenty (120) days of the tender closing date.

TF4 CONSTRUCTION TIME

I/We agree to complete the Work within the time stipulated in the specification from the date of notification of acceptance of my/our bid.

TF5 INSURANCE

Within fourteen (14) calendar days after receipt of written notification of acceptance of my/our bid, I/We will furnish an insurance certificate in accordance with article C9 respectively of the draft Construction Contract.

SIGNED, ATTESTED TO AND DELIVERED on the _____ day of _____ on behalf of:

Print the legal name of the Proponent

Signature of authorized signatory

Signature of authorized signatory

Print name(s) & titles of authorized signatory

Print name(s) & titles of authorized signatory

Signature of Witness

SECTION "IV" - GENERAL INSTRUCTIONS

G11 RESPONSIVENESS

- 1.1 For a proposal to be considered valid, it must comply with all the requirements of this RFP identified as mandatory. Mandatory criteria are also expressed by using imperative verbs such as "shall", "must" and "will".

G12 ENQUIRIES - SOLICITATION STAGE

- 2.1 All enquiries or issues concerning this RFP must be submitted in writing to the Contract Advisor as early as possible within the solicitation period. Enquiries and issues must be received within the timeframe described in article A10 to allow sufficient time to provide a response. Enquiries received after that time will not be answered prior to the Closing Date.
- 2.2 To ensure consistency and quality of information provided to Proponents, the Contract Advisor will give notice, in the same manner as this RFP, of any additional information in response to significant enquiries received without revealing the sources of the enquiries.
- 2.3 All enquiries and other communications with government officials throughout the solicitation period shall be directed ONLY to the Contract Advisor named herein. Non-compliance with this condition during the solicitation period may (for that reason alone) result in the disqualification of your proposal.

G13 PROPONENT'S SUGGESTED IMPROVEMENTS DURING SOLICITATION PERIOD

- 3.1 Should any Proponent consider that the specifications or Statement of Work contained in this RFP can be improved technically or technologically, the Proponent is invited to make suggestions, in writing, to the Contract Advisor named herein. The Proponent must clearly outline the suggested improvements as well as the reason for the suggestion. Suggestions which do not restrict the level of competition nor favour a particular Proponent will be given consideration provided they are received by the Contract Advisor within the timeframe described in A10 to allow sufficient time to provide a response. Her Majesty reserves the right to accept or reject any or all suggestions.

G14 PROPOSAL PREPARATION COST

- 4.1 The costs, including travel incurred by the Proponent in the preparation of its proposal and/or the negotiation (if applicable) of any resulting contract will be the sole responsibility of the Proponent and will not be reimbursed by Her Majesty.

G15 PROPOSAL DELIVERY

- 5.1 Proposals and/or amendments thereto, will only be accepted by the Minister if they are received at the address indicated in A7, on or before the Closing Date and Time specified in A7.
- 5.2 Responsibility for proposal delivery: The Proponent has sole responsibility for the timely receipt of a proposal by Her Majesty and cannot transfer this responsibility to the Government of Canada. Her Majesty will not assume responsibility for proposals that are directed to an email address other than the one stipulated in A7.

G16 VALIDITY OF PROPOSAL

- 6.1 Any proposal must remain open for acceptance for a period of not less than one hundred and twenty (120) calendar days after the Closing Date.

G17 RIGHTS OF CANADA

- 7.1 Her Majesty reserves the right:
- 7.1.1 during the evaluation, to submit questions to or conduct interviews with Proponents, at Proponents cost, upon forty eight (48) hours written notice, to seek clarification or to verify any or all information provided by the Proponent with respect to this RFP;
- 7.1.2 to reject all proposals received in response to this RFP if it/they fail to meet the objectives of the requirement within the boundaries imposed by Her Majesty's different stakeholders;
- 7.1.3 to accept any proposal in whole or in part without prior negotiation;
- 7.1.4 to cancel and/or re-issue this RFP at any time;
- 7.1.5 to award one or more contracts, if applicable;
- 7.1.6 to retain all proposals submitted in response to this RFP;
- 7.1.7 not to accept any deviations from the stated terms and conditions;
- 7.1.8 to incorporate all, or any portion of the Statement of Work, Request for Proposals and the successful proposal in any resulting contract; and
- 7.1.9 not to contract at all.

G18 INCAPACITY TO CONTRACT WITH GOVERNMENT

- 8.1 Canada may reject a proposal where the Proponent, including the Proponent's officers, agents and employees, has been convicted of an offence under the following provisions of the Criminal Code:
- 8.1.1 Section 121, Frauds upon the Government;
- 8.1.2 Section 124, Selling or Purchasing Office; or
- 8.1.3 Section 418, Selling Defective Stores to Her Majesty.
- (Subsection 750 (3) of the Criminal Code prohibits anyone who has been so convicted from holding public office, contracting with the government or benefiting from a government contract.)
- 8.2 Where Canada intends to reject a proposal pursuant to a provision of paragraph 8.1, the Contract Advisor will so inform the Proponent and provide the Proponent ten (10) calendar days within which to make representations, prior to making a final decision on the proposal rejection.

G19 INCURRING OF COST

- 9.1 No costs incurred before receipt of a signed Contract or specified written authorization from the Contract Advisor can be charged to any resulting Contract. In addition, the Contractor is not to perform Work in excess of or outside the scope of any resulting Contract based on verbal or written requests or instructions from any government personnel other than the Contract Advisor. The Proponent's attention is drawn to the fact that the Contract Advisor is the only authority which can commit Her Majesty to the expenditure of the funds for this requirement.

G110 PROPERTY OF HER MAJESTY

- 10.1 All correspondence, documents and information provided to the Minister by any Proponent in connection with this RFP will become the property of Her Majesty and may be released pursuant to the Canadian Federal Access to Information Act and the Privacy Act.

GI11 RIGHTS OF UNSUCCESSFUL PROPONENTS

11.1 Proponents are reminded that all materials submitted by them in either paper or electronic form, including architectural and engineering design drawings, specifications, photographs, etc. shall, upon opening of the proposal by Canadian officials become the property of the Canadian government. In consequence, they will not be returned to the unsuccessful Proponents of this tender competition. The keeping of such information by Canada is necessary to ensure that, in the event of a future internal audit of the tender process, or in the event of a challenge by one of the unsuccessful Proponents to this tender process, all the documents submitted by competing Proponents are available and not tampered with. Nevertheless, complete copyright in those materials will of course remain with the copyright owners of the materials submitted; Canada assures Proponents that it will at no time use those materials for any commercial purposes without the written consent of the authors.

GI12 PRICE SUPPORT

12.1 In the event that the Proponent's bid is the sole responsive proposal received, the Proponent must provide, on the Minister's request, one or more of the following price support if applicable:

- 12.1.1** a current published price list indicating the percentage discount available to the Minister;
- 12.1.2** copies of paid invoices for like services performed for other customers or for like items (same quantity and quality) sold to other customers;
- 12.1.3** a price breakdown showing the cost of direct labour, direct materials, purchased items, engineering and plant overheads, general and administrative overhead, transportation, etc., profit;
- 12.1.4** price or rate certification; and
- 12.1.5** any other supporting documentation as requested by the Minister.

GI13 PROPONENTS NOT TO PROMOTE THEIR INTEREST IN THIS PROJECT

13.1 Proponents must not make any public comment, respond to questions in a public forum or carry out any activities to publicly promote or advertise their interest in this Project, except for their response to Her Majesty pursuant to this RFP.

GI14 ACCEPTANCE OF BIDS

14.1 Proponents must meet and adhere to the architectural and design standards contained in the bid documentation.

14.2 Proponents must submit a list of sub-contractors on TF2 they propose to use on the Works. The successful Proponent shall not be allowed any subsequent substitution of the submitted list of sub-contractors, unless authorized, in advance in writing by Her Majesty.

GI15 SIGNATURES

15.1 The following requirements are to be adhered to when signing the Tender Form:

15.1.1 Corporation

The signatures of the authorized signatories shall be affixed and their names and titles typed or printed.

15.1.2 Partnership

The signatures of the partners shall be affixed and their names typed or printed. If not all of the partners sign or if the signatory is not a partner then a certified true copy of the agreement signed by all partners authorizing such person or persons to execute the document on their behalf shall accompany the bid.

15.1.3 Sole Proprietorship

The signature of the sole proprietor shall be affixed and the name typed or printed. In the event that the signatory is not the sole proprietor then a certified true copy of the agreement signed by the sole proprietor authorizing such person or persons to execute the document shall accompany the bid.

15.1.4 Joint Venture

The signatures of the authorized signatories of each member of the joint venture shall be affixed and their names and titles typed or printed. Each of the participating signatories shall sign the document in the manner applicable to their particular business arrangement which is more particularly described in 15.1.1 to 15.1.3 above.

GI16 RETURN OF DOCUMENTS

16.1 Unsuccessful Proponents must, if requested by the Contract Advisor, return all bid documents (e.g. Working Drawings, Specifications and Bills of Quantities) intact and in good condition within fourteen (14) calendar days of notification. Any copies of the Working Drawings, Specifications and Bill of Quantities are to be returned along with the original bid documents.

GI17 PROPONENT'S CONFERENCE

17.1 Proponents, or their representative(s), are requested to attend a Proponent's conference as described in A9. during which the requirements outlined in this RFP document will be reviewed and any questions will be answered.

17.2 Proponents are advised that any clarifications or changes resulting from the Proponents' conference shall be included as an amendment to the bid solicitation document.

17.3 No expenses will be reimbursed by Her Majesty pursuant to the Proponent's Conference.

GI18 INTERPRETATION

In this RFP, “Her Majesty”, “the Minister” or “Canada” means Her Majesty the Queen in right of Canada, as represented by the Minister of Foreign Affairs.



C. ARTICLES OF AGREEMENT

C1. DEPARTMENTAL REPRESENTATIVE

[Information to be provided at contract award]

DRAFT

Construction Contract

Between

Her Majesty the Queen in right of Canada
(referred to herein as "Her Majesty")
represented by the Minister of Foreign Affairs
(referred to herein as the "Minister")

and

[Information to be provided at contract award]
(referred to herein as the "Contractor")

for

Performance of the Work described in
Appendix "A" – Statement of Work

C2. TITLE Restoration of the Official Residence at the Embassy of Canada to Norway in Oslo		
C3. CONTRACT PERIOD Start: contract award date		Completion Date: October 29, 2021
C4. CONTRACT NUMBER	C5. PROJECT NUMBER Not Applicable.	C6. DATE
C7. CONTRACT DOCUMENTS <ol style="list-style-type: none"> 1. Articles of Agreement 2. Supplementary Conditions (Section "I") 3. Terms of Payment (Section "II") 4. General Conditions (Section "III") 5. Insurance Conditions (Section "IV") 6. Contract Security Conditions (Section "V") 7. Labour Conditions (Section "VI") 8. Statement of Work (Appendix "A") 9. Drawings and Specifications 10. Photographs 11. Request for Proposals 12. Security Requirements Check List 13. Contractor's Proposal <p>In the event of discrepancies, inconsistencies or ambiguities of the wording of these documents, the document that appears first on the above list shall prevail.</p>		
C8. CONTRACT AMOUNT Her Majesty shall pay the contractor a fixed amount of _____kr. The firm amount is: <ol style="list-style-type: none"> a. inclusive of all applicable duties, costs and taxes (other than contractor's Output VAT payable on the Contract price). b. Exclusive of VAT c. in Norwegian Kroner Payments shall be made in accordance with Section "II" Terms of Payment		
C9. INSURANCE The Contractor shall provide a comprehensive general liability insurance of \$1,000,000 CAD in accordance with the Insurance Conditions (Section "IV").		
C10. CONTRACT SECURITY The Contractor shall provide an acceptable contract security of \$0.00 in accordance with the Contract Security Conditions (Section "V").		
C11. MOBILIZATION ADVANCE Not Applicable.		
C12. HOLDBACK Her Majesty shall withhold a holdback, as described in article TP 4.4, of 10% of all progress payments.		
C13. INVOICES One (1) copy to be sent to the Departmental Representative showing: <ol style="list-style-type: none"> a. the amount of the progress payment being claimed for Work satisfactorily performed; b. the amount for any tax (including VAT) calculated in accordance with the applicable legislation; c. the date; d. the name and address of the consignee; e. description of the Work performed; f. the project name; and g. the contract number. 		
C14. GOVERNING LAWS Laws in force in the Province of Ontario, Canada		
FOR THE CONTRACTOR _____ SIGNATURE _____ PRINT NAME AND CAPACITY		_____ DATE Corporate Seal
FOR THE MINISTER _____ SIGNATURE _____ PRINT NAME AND CAPACITY		

SECTION "I" – SUPPLEMENTARY CONDITIONS**1. SECURITY REQUIREMENTS**

The Contractor and/or all other personnel involved in the Work must be properly supervised on the premises of the Mission, Official Residence or Staff quarter. No access to the restricted zones of the Mission will be permitted. See the attached Security Requirements Checklist for further details.

2. HEALTH AND SAFETY

The Contractor must comply with all requirements of applicable Canadian (federal, provincial, municipal), foreign and local environmental, health and safety laws and regulations. The Contractor must follow the prevention and infection control measures of the workplace or put in place by the Canadian mission (i.e. practise physical distancing, practise proper hand washing, avoid touching face with unwashed hands, etc.) and follow the proper protocols to complete the required work such as utilizing the appropriate equipment and personal protective equipment (PPE) as necessary. The Contractor is responsible for all costs associated with the compliance to protective measures and any other costs related to the general health and safety of its employees and agents.

SECTION "II" – TERMS OF PAYMENT**TP1 AMOUNT PAYABLE - GENERAL**

- 1.1** Subject to any other provisions of this Contract, Her Majesty shall pay the Contractor, at the times and in the manner hereinafter set out, the amount by which:
- 1.1.1** the aggregate of the amounts described in TP2 exceeds; and
 - 1.1.2** the aggregate of the amounts described in TP3;
- and the Contractor shall accept that amount as payment in full satisfaction for everything furnished and done by him in respect of the Work to which the payment relates.
- 1.2** Subject to any other provisions in this Contract, "Days" shall mean continuous calendar days including weekends and statutory public holidays.

TP2 AMOUNT PAYABLE TO THE CONTRACTOR

- 2.1** The amounts referred to in TP1.1.1 are the aggregate of:
- 2.1.1** The contract amount referred to in C8 of the Articles of Agreement; and
 - 2.1.2** The amounts, if any, that are payable to the Contractor pursuant to the General Conditions.

TP3 AMOUNT PAYABLE TO HER MAJESTY

- 3.1** The amounts referred to in TP1.1.2 are the aggregate of the amounts, if any, that the Contractor is liable to pay Her Majesty pursuant to the Contract.
- 3.2** When making any payment to the Contractor, the failure of Her Majesty to deduct an amount referred to in TP3.1 from an amount referred to in TP2 shall not constitute a waiver of the right to do so, or an admission of lack of entitlement to do so in any subsequent payment to the Contractor.

TP4 TIME OF PAYMENT

- 4.1** In these Terms of Payment:
- 4.1.1** The "payment period" means a period of thirty (30) consecutive days or such other longer period as is agreed between the Contractor and the Departmental Representative;
 - 4.1.2** An amount is "due and payable" when it is due and payable by Her Majesty to the Contractor according to TP4.4, TP4.7 or TP4.10;
 - 4.1.3** An amount is overdue when it is unpaid on the first day following the day upon which it is due and payable;
 - 4.1.4** The "date of payment" means the date of the negotiable instrument of an amount due and payable by the Receiver General for Canada and given for payment; and
 - 4.1.5** The "Bank Rate" means the discount rate of interest set by the Bank of Canada in effect at the opening of business on the date of payment.

Progress Payments

- 4.2** The Contractor shall, on the expiration of a payment period, deliver to the Departmental Representative in respect of that payment period a written progress claim in a form acceptable to the Departmental Representative that fully describes any part of the Work that has been completed (including its percentage of the total Work), and any material that was delivered to the work site but not incorporated into the Work, during that payment period.
- 4.3** The Departmental Representative shall, not later than ten days after receipt by him of a progress claim referred to in TP4.2:
- 4.3.1** Inspect, or cause to have inspected, the part of the Work and the material described in the progress claim; and
 - 4.3.2** Determine the value of the part of the Work and the material described in the progress claim that, in the opinion of the Departmental Representative:
 - 4.3.2.1** is in accordance with the Contract, and
 - 4.3.2.2** was not paid for in any other progress claim relating to the Contract.

- 4.4 Subject to TP1 and TP4.5 Her Majesty shall, no later than thirty (30) days after the receipt by the Departmental Representative of a progress claim referred to in TP4.2, pay the Contractor an amount that is equal to the value that is determined under TP4.3.2 less a holdback as stated in C12.
- 4.5 It is a condition precedent to Her Majesty's obligation under TP4.4 that the Contractor has made and delivered to the Departmental Representative a statutory declaration in respect of a progress claim referred to in TP4.2.
- 4.6 A statutory declaration referred to in TP4.5 shall contain a deposition by the Contractor that up to the date immediately preceding the Contractor's latest progress claim, all lawful obligations of the Contractor with regard to subcontractors and suppliers of material in respect of the Work under the Contract have been fully discharged.

Interim Certificate of Completion

- 4.7 Subject to TP1 and TP4.8, Her Majesty shall, not later than thirty (30) days after the date of issue of an Interim Certificate of Completion referred to in GC44.2, pay to the Contractor an amount that is equal to the amount referred to in TP1, less the aggregate of:
- 4.7.1 An amount that is equal to the Departmental Representative's estimate of the cost to Her Majesty of rectifying defects and deficiencies described in the Interim Certificate of Completion; and
- 4.7.2 an amount that is equal to the total of all payments made by Her Majesty under TP4.4.
- 4.8 It is a condition precedent to Her Majesty's obligation under TP4.7 that the Contractor has made and delivered to the Departmental Representative a statutory declaration described in TP4.9 in respect of an Interim Certificate of Completion referred to in GC44.2.
- 4.9 A statutory declaration referred to in TP4.8 shall contain a deposition by the Contractor that up to the date of the Interim Certificate of Completion the Contractor has:
- 4.9.1 Discharged all of the Contractor's lawful obligations to the subcontractors and suppliers of material in respect of the Work under the Contract; and
- 4.9.2 Discharged the Contractor's obligations referred to in GC14.6.

Final Certificate of Completion

- 4.10 Subject to TP1 and TP4.11, Her Majesty shall, not later than sixty (60) days after the date of issue of a Final Certificate of Completion referred to in GC44.1, pay the Contractor the amount referred to in TP1 less the sum of all payments that were made pursuant to TP4.4 and TP4.7.
- 4.11 It is a condition precedent to Her Majesty's obligation under TP4.10 that the Contractor has made and delivered a statutory declaration described in TP4.12 to the Departmental Representative.
- 4.12 A statutory declaration referred to in TP4.11 shall, in addition to the depositions described in TP4.9, contain a deposition by the Contractor that all of the Contractor's lawful obligations and any lawful claims against the Contractor that arose out of the performance of the Contract have been discharged and satisfied.

TP5 PROGRESS REPORT AND PAYMENT THEREUNDER NOT BINDING ON HER MAJESTY

Neither a progress claim referred to in TP4.3 nor any payment made by Her Majesty pursuant to these Terms of Payment shall be construed as an admission by Her Majesty that the Work, material or any part thereof is complete, is satisfactory or is in accordance with the Contract.

TP6 DELAY IN MAKING PAYMENT

- 6.1 Notwithstanding GC7 any delay by Her Majesty in making any payment when it is due pursuant to these Terms of Payment shall not be a breach of the Contract by Her Majesty.
- 6.2 Her Majesty shall be liable to pay to the Contractor simple interest at the average Bank Rate as defined in TP9.2.2 plus three percent (3%) per annum on any amount that is overdue, from the date such amount becomes overdue until the day prior to the date of payment, inclusive. No interest will be payable or paid in respect of payment unless the Contractor so requests after payment has become due.

6.3 Interest shall not be payable or paid unless the amount referred to in TP6.2 has been overdue for more than fifteen (15) days following:

6.3.1 The date the said amount became due and payable; or

6.3.2 The receipt by the Departmental Representative of the statutory declaration referred to in TP4.5, TP4.8 or TP4.11;
whichever is the later, and

6.3.3 Interest shall not be payable or paid on overdue advance payments if any.

TP7 RIGHT OF SET-OFF

7.1 Without limiting any right of set-off or deduction given or implied by law or elsewhere in the Contract, Her Majesty may set-off any amount payable to Her Majesty by the Contractor under this Contract or under any current contract against any amount payable to the Contractor under this Contract.

7.2 For the purposes of TP7.1, "current contract" means a contract between Her Majesty and the Contractor:

7.2.1 under which the Contractor has an undischarged obligation to perform or supply work, labour or material; or

7.2.2 In respect of which Her Majesty has, since the date on which the Articles of Agreement were made, exercised any right to take the Work that is the subject of the Contract out of the Contractor's hands.

TP8 PAYMENT IN EVENT OF TERMINATION

If the Contract is terminated pursuant to GC41, Her Majesty shall pay the Contractor any amount that is lawfully due and payable to the Contractor as soon as is practicable under the circumstances.

TP9 INTEREST ON SETTLED CLAIMS

9.1 Her Majesty shall pay to the Contractor simple interest on the amount of a settled claim at an average Bank of Canada Rate plus one and a quarter percent (1.25%) from the date the settled claim was outstanding until the day prior to the date of payment.

9.2 For the purposes of TP9.1:

9.2.1 A claim is deemed to have been settled when an agreement in writing is signed by the Departmental Representative and the Contractor setting out the amount of the claim to be paid by Her Majesty and the items of work for which the said amount is to be paid.

9.2.2 An "average Bank Rate" means the discount rate of interest set by the Bank of Canada in effect at the end of each calendar month averaged over the period the settled claim was outstanding.

9.2.3 A settled claim is deemed to be outstanding from the day immediately following the date the said claim would have been due and payable under the Contract had it not been disputed.

9.2.4 A claim means a disputed amount subject to negotiation between Her Majesty and the Contractor under the Contract.

TP10 TAXES

10.1 If applicable, the VAT or Canadian Goods and Services Tax (GST) is to be shown separately on all invoices and progress claims for Work performed, and will be paid by Her Majesty. The Contractor agrees to remit any GST due to Revenue Canada.

10.2 THE GOVERNMENT OF CANADA GST REGISTRATION NUMBER IS 121491807.

TP11 MOBILIZATION ADVANCE (IF ANY)

Not applicable.

Section "III" - General Conditions

GC1 INTERPRETATION**1.1** In the Contract:

- 1.1.1** Where reference is made to a part of the Contract by means of numbers receded by letters, the reference shall be construed to be a reference to the particular part of the Contract that is identified by that combination of letters and numbers and to any other part of the Contract referred to therein;
- 1.1.2** "Contract" means the Contract Documents referred to in the Articles of Agreement;
- 1.1.3** "Contract security" means any security given by the Contractor to Her Majesty in accordance with the Contract;
- 1.1.4** "Days" means continuous calendar days, including weekends and statutory public holidays;
- 1.1.5** "Departmental Representative" means the officer, employee or person engaged by Her Majesty who is designated pursuant to the Articles of Agreement and includes a person specially authorized by him to perform, on his behalf, any of his functions under the Contract and is so designated in writing to the Contractor;
- 1.1.6** "Former Public Office Holder" means an employee of the executive or senior manager categories who was employed by the Canadian federal public service during the period of one (1) year immediately preceding the date of this Contract;
- 1.1.7** "Material" includes all commodities, articles and things required to be furnished by or for the Contractor under the Contract for incorporation into the Work;
- 1.1.8** "Minister" includes a person acting for, or if the office is vacant, in place of the Minister and his successors in the office, and his or their lawful deputy and any of his or their representatives appointed for the purposes of the Contract;
- 1.1.9** "Person" includes, unless the context otherwise requires, a partnership, proprietorship, firm, joint venture, consortium and a corporation;
- 1.1.10** "Plant" includes all animals, tools, implements, machinery, vehicles, buildings, structures, equipment and commodities, articles and things other than material, that are necessary for the due performance of the Contract;
- 1.1.11** "Subcontractor" means a person to whom the Contractor has, subject to GC4, subcontracted the whole or any part of the Work;
- 1.1.12** "Superintendent" means the employee of the Contractor who is designated by the Contractor to act pursuant to GC19;
- 1.1.13** "Technical documentation" means designs, reports, photographs, surveys, drawings, plans, specifications, computer software, computer printouts, calculations and other data, information and material, prepared, collected, computed, drawn, or produced for the Work; and
- 1.1.14** "Work" includes, subject only to any express stipulation in the Contract to the contrary,

everything that is necessary to be done, furnished or delivered by the Contractor to perform the Contract.

- 1.2** The headings in the Contract documents, other than in the Plans and Specifications, form no part of the Contract but are inserted for convenience of reference only.
- 1.3** In interpreting the Contract, in the event of discrepancies or conflicts between anything in the Plans and Specifications and the General Conditions, the General Conditions govern.
- 1.4** Words importing the singular only also include the plural, and vice versa, where the context requires;
- 1.5** Headings or notes in the Contract shall not be deemed to be part thereof, or be taken into consideration in its interpretation;
- 1.6** "Herein," "hereby," "hereof," "hereunder" and similar expressions refer to the Contract as a whole and not to any particular subdivision or part thereof.
- 1.7** In interpreting the Plans and Specifications, in the event of discrepancies or conflicts between:
- 1.7.1** The Plans and Specifications, the Specifications govern;
- 1.7.2** The Plans, the Plans drawn with the largest scale govern; and
- 1.7.3** Figured dimensions and scaled dimensions, the figured dimensions govern.

GC2 SUCCESSORS AND ASSIGNS

The Contract shall inure to the benefit of and be binding upon the parties hereto and their lawful heirs, executors, administrators, successors and assigns.

GC3 ASSIGNMENT OF CONTRACT

The Contract may not be assigned by the Contractor, either in whole or in part, without the written consent of the Minister.

GC4 SUBCONTRACTING BY CONTRACTOR

- 4.1** Subject to this General Condition, the Contractor may subcontract any part of the Work.
- 4.2** The Contractor shall notify the Departmental Representative in writing of his intention to subcontract.
- 4.3** A notification referred to in GC4.2 shall identify the part of the Work, and the subcontractor with whom it is intended to subcontract.
- 4.4** The Departmental Representative may object to the intended subcontracting by notifying the Contractor in writing within six (6) days of receipt by the Departmental Representative of a notification referred to in GC4.2.
- 4.5** If the Departmental Representative objects to a subcontracting pursuant to GC4.4, the Contractor shall not enter into the intended subcontract.
- 4.6** The Contractor shall not, without the written consent of the Departmental Representative, change a subcontractor who has been engaged by him in accordance with this General Condition.
- 4.7** Every subcontract entered into by the Contractor shall adopt all of the terms and conditions of this Contract that are of general application.
- 4.8** Neither a subcontracting nor the Departmental Representative's consent to a subcontracting by the

Contractor shall be construed to relieve the Contractor from any obligation under the Contract or to impose any liability upon Her Majesty.

GC5 AMENDMENTS

No amendment or change in any of the provisions of the Contract shall have any force or effect until it is reduced to writing and signed by both parties.

GC6 NO IMPLIED OBLIGATIONS

- 6.1** No implied terms or obligations of any kind by or on behalf of Her Majesty shall arise from anything in the Contract and the express covenants and agreements therein contained and made by Her Majesty are the only covenants and agreements upon which any rights against Her Majesty are to be founded.
- 6.2** The Contract supersedes all communications, negotiations and agreements, either written or oral, relating to the Work that were made prior to the date of the Contract.

GC7 TIME OF THE ESSENCE

- 7.1** Time is of the essence of the Contract.

GC8 INDEMNIFICATION BY CONTRACTOR

- 8.1** The Contractor shall indemnify and save Her Majesty harmless from and against all claims, demands, losses, costs, damages, actions, suits, or proceedings by whomever made, brought or prosecuted and in any manner based upon, arising out of, related to, occasioned by or attributable to the activities of the Contractor, his servants, agents, subcontractors and sub-subcontractors in performing the Work including an infringement or an alleged infringement of a patent of invention or any other kind of intellectual property.
- 8.2** For the purposes of GC8.1, "activities" includes any act improperly carried out, any omission to carry out an act and any delay in carrying out an act.

GC9 INDEMNIFICATION BY HER MAJESTY

- 9.1** Her Majesty shall, subject to the Crown Liability Act, the Patent Act, and any other law that affects Her Majesty's rights, powers, privileges or obligations, indemnify and save the Contractor harmless from and against all claims, demands, losses, costs, damage, actions, suits or proceedings arising out of his activities under the Contract that are directly attributable to:
- 9.1.1** Lack of or a defect in Her Majesty's title to the work site whether real or alleged; or
- 9.1.2** An infringement or an alleged infringement by the Contractor of any patent of invention or any other kind of intellectual property occurring while the Contractor was performing any act for the purposes of the Contract employing a model, plan or design or any other thing related to the Work that was supplied by Her Majesty to the Contractor.

GC10 MEMBERS OF HOUSE OF COMMONS NOT TO BENEFIT

As required by the Parliament of Canada Act, it is an

express condition of the Contract that no member of the Canadian House of Commons shall be admitted to any share or part of the Contract or to any benefit arising therefrom.

GC11 NOTICES

- 11.1** Any notice, consent, order, decision, direction or other communication, other than a notice referred to in GC11.4, that may be given to the Contractor pursuant to the Contract may be given in any manner.
- 11.2** Any notice, consent, order, decision, direction or other communication required to be given in writing, to any party pursuant to the Contract shall, subject to GC11.4, be deemed to have been effectively given:
- 11.2.1** to the Contractor, if delivered personally to the Contractor or the Contractor's superintendent, or forwarded by mail, email or facsimile to the Contractor at the address set out in the Articles of Agreement; or
- 11.2.2** to Her Majesty, if delivered personally to the Departmental Representative, or forwarded by mail, email or facsimile to the Departmental Representative at the address set out in C1.
- 11.3** Any such notice, consent, order, decision, direction or other communication given in accordance with GC11.2 shall be deemed to have been received by either party:
- 11.3.1** If delivered personally, on the day that it was delivered;
- 11.3.2** If forwarded by mail, on the earlier of the day it was received and the sixth (6th) day after it was mailed; and
- 11.3.3** If forwarded by email or facsimile, twenty-four (24) hours after it was transmitted.
- 11.4** A notice given under GC38.1.1, GC40 and GC41, if delivered personally, shall be delivered to the Contractor if the Contractor is doing business as a sole proprietor or, if the Contractor is a partnership or corporation, to an officer thereof.

GC12 MATERIAL, PLANT AND REAL PROPERTY SUPPLIED BY HER MAJESTY

- 12.1** Subject to GC12.2, the Contractor is liable to Her Majesty for any loss of or damage to material, plant or real property that is supplied or placed in the care, custody and control of the Contractor by Her Majesty for use in connection with the Contract, whether or not that loss or damage is attributable to causes beyond the Contractor's control.
- 12.2** The Contractor is not liable to Her Majesty for any loss or damage to material, plant or real property referred to in GC12.1 if that loss or damage results from and is directly attributable to reasonable wear and tear.
- 12.3** The Contractor shall not use any material, plant or real property referred to in GC12.1 except for the purpose of performing this Contract.
- 12.4** If the Contractor fails to make good any loss or damage for which he is liable under GC12.1 within a reasonable time after being required to do so by the Departmental Representative, the Departmental

- Representative may cause the loss or damage to be made good at the Contractor's expense, and the Contractor shall thereupon be liable to Her Majesty for the cost thereof and shall, on demand, pay to Her Majesty an amount equal to that cost.
- 12.5** The Contractor shall keep such records of all material, plant and real property referred to in GC12.1 as the Departmental Representative from time to time requires and shall satisfy the Departmental Representative, when requested, that such material, plant and real property are at the place and in the condition in which they ought to be.
- GC13 MATERIAL, PLANT AND REAL PROPERTY BECOME PROPERTY OF HER MAJESTY**
- 13.1** Subject to GC14.7 all material and plant and the interest of the Contractor in all real property, licences, powers and privileges purchased, used or consumed by the Contractor for the Contract shall become the property of Her Majesty for the purposes of the Work and they shall continue to be the property of Her Majesty:
- 13.1.1** In the case of material, until the Departmental Representative indicates that he is satisfied that it will not be required for the Work; and
- 13.1.2** In the case of plant, real property, licenses, powers and privileges, until the Departmental Representative indicates that he is satisfied that the interest vested in Her Majesty therein is no longer required for the purposes of the Work.
- 13.2** Material or plant that is the property of Her Majesty by virtue of GC13.1 shall not be taken away from the work site or used or disposed of except for the purposes of the Work without the written consent of the Departmental Representative.
- 13.3** Her Majesty is not liable for loss of or damage from any cause to the material or plant referred to in GC13.1 and the Contractor is liable for such loss or damage notwithstanding that the material or plant is the property of Her Majesty.
- GC14 PERMITS AND TAXES PAYABLE**
- 14.1** The Contractor shall, within fifteen (15) days after the date of the Contract, tender to a municipal authority an amount equal to all fees and charges that would be lawfully payable to that municipal authority in respect of building permits as if the Work were being performed for a person other than Her Majesty.
- 14.1.1** The Contractor shall be responsible for obtaining and pay for all necessary permits for all the Work to be undertaken under the Contract. He shall give all notices and comply with all laws, rules and regulations bearing on the conduct of the Work as drawn and specified.
- 14.2** Within ten (10) days of making a tender pursuant to GC14.1, the Contractor shall notify the Departmental Representative of his action and of the amount tendered and whether or not the municipal authority has accepted that amount.
- 14.3** If the municipal authority does not accept the amount tendered pursuant to GC14.1 the Contractor shall pay that amount to Her Majesty within six (6) days after the time stipulated in GC14.2.
- 14.4** For the purposes of GC14.1 to GC14.3 "municipal authority" means any authority that would have jurisdiction respecting permission to perform the Work if the owner were not Her Majesty.
- 14.5** The Contractor shall pay any and all applicable taxes arising from or relating to the performance of the Work under the Contract. The Contractor shall also determine the extent of, and apply for, any and all exemptions that are, or may be, available due to the status of Her Majesty as a sovereign entity. Where the Contractor procures goods for incorporation into the Work, for such purposes, the Contractor shall be an agent of Her Majesty. Any such exemptions that are available shall be applied to the benefit of Her Majesty. The Contractor shall obtain and provide sufficient documentation from the relevant authorities as to the availability of such exemptions.
- 14.6** In performing the Work under the Contract, the Contractor shall abide by all of the laws in force in the local jurisdiction. Should the Contractor fail to pay any dues or taxes payable under those laws, the Minister, after giving the Contractor seven (7) days prior written notice of his intention so to do, shall have the right to pay directly any such dues or taxes claimed, and deduct same from any payment due to the Contractor.
- 14.7** For the purpose of the payment of any and all applicable taxes or the furnishing of security for the payment of any and all applicable taxes arising from or related to the performance of the Work under the Contract, the Contractor shall, notwithstanding the fact that all material, plant and interest of the Contractor in all real property, licences, powers and privileges, have become the property of Her Majesty after the time of purchase, be liable, as a user or consumer, for the payment or for the furnishing of security for the payment of any and all applicable taxes payable, at the time of the use or consumption of that material, plant or interest of the Contractor in accordance with the relevant legislation.
- GC15 PERFORMANCE OF WORK UNDER DIRECTION OF DEPARTMENTAL REPRESENTATIVE**
- The Contractor shall:
- 15.1.1** Permit the Departmental Representative to have access to the Work and its site at all times during the performance of the Contract;
- 15.1.2** Furnish the Departmental Representative with such information respecting the performance of the Contract as he may require; and
- 15.1.3** Give the Departmental Representative every possible assistance to enable the Departmental Representative to carry out his duty to see that the Work is performed in accordance with the Contract and to carry out any other duties and exercise any powers specially imposed or conferred on the Departmental Representative under the Contract.

- GC16 COOPERATION WITH OTHER CONTRACTORS**
- 16.1** Where, in the opinion of the Departmental Representative, it is necessary that other contractors or workers with or without plant and material, be sent onto the Work or its site, the Contractor shall, to the satisfaction of the Departmental Representative, allow them access and cooperate with them in the carrying out of their duties and obligation.
- 16.2** If:
- 16.2.1** the sending onto the Work or its site of other contractors or workers pursuant to GC16.1 could not have been reasonably foreseen or anticipated by the Contractor when entering into the Contract;
- 16.2.2** the Contractor incurs, in the opinion of the Departmental Representative, extra expense in complying with GC16.1; and
- 16.2.3** the Contractor has given the Departmental Representative written notice of his claim for the extra expense referred to in GC16.2.2 within thirty (30) days of the date that the other contractors or workers were sent onto the Work or its site;
- 16.3** Her Majesty shall pay the Contractor the cost, calculated in accordance with GC48 to GC50, of the extra labour, plant and material that was necessarily incurred.
- GC17 EXAMINATION OF WORK**
- 17.1** If, at any time after the commencement of the Work but prior to the expiry of the warranty or guarantee period, the Departmental Representative has reason to believe that the Work or any part thereof has not been performed in accordance with the Contract, the Departmental Representative may have that Work examined by an expert of his choice.
- 17.2** If, as a result of an examination of the Work referred to in GC17.1, it is established that the Work was not performed in accordance with the Contract, then, in addition to and without limiting or otherwise affecting any of Her Majesty's rights and remedies under the Contract either at law or in equity, the Contractor shall pay Her Majesty, on demand, all reasonable costs and expenses that were incurred by Her Majesty in having that examination performed.
- GC18 CLEARING OF SITE**
- 18.1** The Contractor shall maintain the Work and its site in a tidy condition and free from the accumulation of waste material and debris, in accordance with any directions of the Departmental Representative.
- 18.2** Before the issue of an Interim Certificate of Completion referred to in GC44.2, the Contractor shall remove all the plant and material not required for the performance of the remaining Work, and all waste material and other debris, and shall cause the Work and its site to be clean and suitable for occupancy by Her Majesty's servants, unless otherwise stipulated in the Contract.
- 18.3** Before the issue of a Final Certificate of Completion referred to in GC44.1, the Contractor shall remove from the Work and its site all of the surplus plant and material and any waste material and other debris.
- 18.4** The Contractor's obligations described in GC18.1 to GC18.3 do not extend to waste material and other debris caused by Her Majesty's servants or contractors and workers referred to in GC16.1
- GC19 CONTRACTOR'S SUPERINTENDENT**
- 19.1** The Contractor shall, forthwith upon the award of the Contract, designate a superintendent.
- 19.2** The Contractor shall forthwith notify the Departmental Representative of the name, address and telephone number of a superintendent designated pursuant to GC19.1.
- 19.3** A superintendent designated pursuant to GC19.1 shall be in full charge of the operations of the Contractor in the performance of the Work and is authorized to accept any notice, consent, order, direction, decision or other communication on behalf of the Contractor that may be given to the superintendent under the Contract.
- 19.4** The Contractor shall, until the Work has been completed, keep a competent superintendent at the work site during working hours.
- 19.5** The Contractor shall, upon the request of the Departmental Representative, remove any superintendent who, in the opinion of the Departmental Representative, is incompetent or has been conducting himself improperly and shall forthwith designate another superintendent who is acceptable to the Departmental Representative.
- 19.6** Subject to GC19.5, the Contractor shall not substitute a superintendent without the written consent of the Departmental Representative.
- 19.7** A breach by the Contractor of GC19.6 entitles the Departmental Representative to refuse to issue any certificate referred to in GC44 until the superintendent has returned to the work site or another superintendent who is acceptable to the Departmental Representative has been substituted.
- GC20 NATIONAL SECURITY**
- 20.1** If the Minister is of the opinion that the Work is of a class or kind that involves the national security of Canada, he may order the Contractor:
- 20.1.1** To provide him with any information concerning persons employed or to be employed by him for purposes of the Contract; and
- 20.1.2** To remove any person from the Work and its site if, in the opinion of the Minister, that person may be a risk to the national security.
- 20.2** The Contractor shall, in all contracts with persons who are to be employed in the performance of the Contract, make provision for his performance of any obligation that may be imposed upon him under GC19 to GC21.
- 20.3** The Contractor shall comply with an order of the Minister under GC20.1.
- GC21 UNSUITABLE WORKERS**
- The Contractor shall, upon the request of the Departmental Representative, remove any person employed by him for purposes of the Contract who, in the opinion of the Departmental Representative,

	is incompetent or has conducted himself improperly, and the Contractor shall not permit a person who has been removed to return to the work site.		Representative to be taken to ensure the maintenance of the degree of security that is ascribed to that rating.
GC22	INCREASED OR DECREASED COSTS	24.3	The Contractor shall provide all facilities necessary for the purpose of maintaining security, and shall assist any person authorized by the Minister to inspect or to take security measures in respect of the Work and its site.
22.1	The amount set out in the Articles of Agreement shall not be increased or decreased by reason of any increase or decrease in the cost of the Work that is brought about by an increase or decrease in the cost of labour, plant or material or any wage adjustment.	24.4	The Departmental Representative may direct the Contractor to do such things and to perform such additional Work as the Departmental Representative considers reasonable and necessary to ensure compliance with or to remedy a breach of GC24.1 to GC24.3.
22.2	Notwithstanding GC22.1 and GC35, an amount set out in the Articles of Agreement shall be adjusted in the manner provided in GC22.3, if any change occurs in a tax imposed under any sales tax legislation applicable under the governing law of this Contract relative to the purchase of tangible personal property to be incorporated into Real Property:	GC25	PUBLIC CEREMONIES AND SIGNS
22.2.1	Occurs after the date of the submission by the Contractor of his tender for the Contract;	25.1	The Contractor shall not permit any public ceremony in connection with the Work without the prior written consent of the Departmental Representative.
22.2.2	Applies to material; and	25.2	The Contractor shall not erect or permit the erection of any sign or advertising on the Work or its site without the prior written consent of the Departmental Representative.
22.2.3	Affects the cost to the Contractor of that material.	GC26	PRECAUTIONS AGAINST DAMAGE, INFRINGEMENT OF RIGHTS, FIRE, AND OTHER HAZARDS
22.3	If a change referred to in GC22.2 occurs, the appropriate amount set out in the Articles of Agreement shall be increased or decreased by an amount equal to the amount that is established by an examination of the relevant records of the Contractor referred to in GC51 to be the increase or decrease in the cost incurred that is directly attributable to that change.	26.1	The Contractor shall, at his own expense, do whatever is necessary to ensure that:
22.4	For the purpose of GC22.2, where a tax is changed after the date of submission of the tender but public notice of the change has been given by the appropriate local tax authorities before that date, the change shall be deemed to have occurred before the date of submission of the tender.	26.1.1	No person, property, right, easement or privilege is injured, damaged or infringed by reasons of the Contractor's activities in performing the Contract;
GC23	LABOUR AND MATERIAL	26.1.2	Pedestrian and other traffic on any public or private road or waterway is not unduly impeded, interrupted or endangered by the performance or existence of the Work or plant;
23.1	The Contractor shall at all time enforce strict discipline and good order amongst his employees, professional consultants and subcontractors and shall not employ on the Work any unfit person nor anyone unskilled in the Work assigned to him.	26.1.3	Fire hazards in or about the Work or its site are eliminated and, subject to any direction that may be given by the Departmental Representative, any fire is promptly extinguished;
23.2	The Contractor warrants that all materials and workmanship to be supplied by him shall be of a quality consistent with the specifications of the Contract.	26.1.4	The health and safety of all persons employed in the performance of the Work are not endangered by the method or means of its performance;
GC24	PROTECTION OF WORK AND DOCUMENTS	26.1.5	Adequate medical services are available to all persons employed on the Work or its site at all times during the performance of the Work;
24.1	The Contractor shall guard or otherwise protect the Work and its site, and protect the Contract, specifications, plans, drawings, information, material, plant and real property, whether or not they are supplied by Her Majesty to the Contractor, against loss or damage from any cause, and he shall not use, issue, disclose or dispose of them without the written consent of the Minister, except as may be essential for the performance of the Work.	26.1.6	Adequate sanitation measures are taken in respect of the Work and its site; and
24.2	If any document or information given or disclosed to the Contractor is assigned a security rating by the person who gave or disclosed it, the Contractor shall take all measures directed by the Departmental	26.1.7	All stakes, buoys and marks placed on the Work or its site by or under the authority of the Departmental Representative are protected and are not removed, defaced, altered or destroyed.
		26.2	The Departmental Representative may direct the Contractor to do such things and to perform such additional Work as the Departmental Representative considers reasonable and necessary to ensure compliance with or to remedy a breach of GC26.1.
		26.3	The Contractor shall, at his own expense, comply

	with a direction of the Departmental Representative made under GC26.2.		
GC27	INSURANCE		
27.1	The Contractor shall, at his own expense, obtain and maintain insurance contracts in respect of the Work and shall provide evidence thereof to the Departmental Representative in accordance with the requirements of the Insurance Conditions in Section "IV."	28.6	If an election is not made pursuant to GC28.1.2 the Contractor shall, subject to GC28.7, clear and clean the Work and its site and restore and replace the part of the Work that was lost, damaged or destroyed at his own expense as if that part of the Work had not yet been performed.
27.2	The insurance Contracts referred to in GC27.1 shall:	28.7	When the Contractor clears and cleans the Work and its site and restores and replaces the Work referred to in GC28.6, Her Majesty shall pay him out of the monies referred to in GC28.1 so far as they will there unto extend.
27.2.1	be in a form, of the nature, in the amounts, for the periods and containing the terms and conditions specified in Insurance Conditions in Section "IV"; and	28.8	Subject to GC28.7, payment by Her Majesty pursuant to GC28.7 shall be made in accordance with the Contract but the amount of each payment shall be one hundred percent (100%) of the amount claimed notwithstanding TP4.4.
27.2.2	Provide for the payment of claims under such insurance Contracts in accordance with GC28.		
GC28	INSURANCE PROCEEDS	GC29	CONTRACT SECURITY
28.1	In the case of a claim payable under a Builders Risk/Installation (All Risks) insurance Contract maintained by the Contractor pursuant to GC27, the proceeds of the claim shall be paid directly to Her Majesty, and:	29.1	The Contractor shall obtain and deliver contract security to the Departmental Representative in accordance with the provisions of the document attached hereto, marked Section "V" and entitled Contract Security Conditions.
28.1.1	the monies so paid shall be held by Her Majesty for the purposes of the Contract; or	29.2	If the whole or a part of the contract security referred to in GC29.1 is in the form of a security deposit, it shall be held and disposed of in accordance with GC43 and GC45.
28.1.2	Her Majesty elects, shall be retained by Her Majesty, in which event they vest in Her Majesty absolutely.	29.3	If a part of the contract security referred to in GC29.1 is in the form of a labour and material payment bond, the Contractor shall post a copy of that bond on the work site.
28.2	In the case of a claim payable under a General Liability insurance Contract maintained by the Contractor pursuant to GC27, the proceeds of the claim shall be paid by the insurer directly to the claimant.	GC30	CHANGES IN THE WORK
28.3	If an election is made pursuant to GC28.1, the Minister may cause an audit to be made of the accounts of the Contractor and of Her Majesty in respect of the part of the Work that was lost, damaged or destroyed for the purpose of establishing the difference, if any, between:	30.1	Subject to GC5, the Departmental Representative may, at any time before he issues the Final Certificate of Completion:
28.3.1	the aggregate of the amount of the loss or damage suffered or sustained by Her Majesty, including any costs incurred in respect of the clearing and cleaning of the Work and its site and any other amount that is payable by the Contractor to Her Majesty under the Contract, minus any monies retained pursuant to GC28.1.2; and	30.1.1	Order Work or material in addition to that provided for in the Plans and Specifications; and
28.3.2	The aggregate of the amounts payable by Her Majesty to the Contractor pursuant to the Contract up to the date of the loss or damage.	30.1.2	Delete or change the dimensions, character, quantity, quality, description, location or position of the whole or any part of the Work or material provided for in the Plans and Specifications or in any order made pursuant to GC30.1.1, if that additional Work or material, deletion, or change is, in his opinion, consistent with the general intent of the original Contract.
28.4	A difference that is established pursuant to GC28.3 shall be paid forthwith by the party who is determined by the audit to be the debtor to the party who is determined by the audit to be the creditor.	30.2	The Contractor shall perform the Work in accordance with such orders, deletions and changes that are made by the Departmental Representative pursuant to GC30.1 from time to time as if they had appeared in and been part of the Plans and Specifications.
28.5	When payment of a deficiency has been made pursuant to GC28.4, all rights and obligations of Her Majesty and the Contractor under the Contract shall, with respect only to the part of the Work that was the subject of the audit referred to in GC28.3, be deemed to have been expended and discharged.	30.3	The Departmental Representative shall determine whether or not anything done or omitted by the Contractor pursuant to an order, deletion or change referred to in GC30.1 increased or decreased the cost of the Work to the Contractor.
		30.4	If the Departmental Representative determines pursuant to GC30.3 that the cost of the Work to the Contractor has been increased, Her Majesty shall pay the Contractor the increased cost that the Contractor necessarily incurred for the additional

<p>30.5 Work calculated in accordance with GC49 or GC50. If the Departmental Representative determines pursuant to GC30.3 that the cost of the Work to the Contractor has been decreased, Her Majesty shall reduce the amount payable to the Contractor under the contract by an amount equal to the decrease in the cost caused by the deletion or change referred to in GC30.1.2 and calculated in accordance with GC49.</p> <p>30.6 GC30.3 to GC30.5 are applicable only to a contract or a portion of a contract for which a Fixed Price Arrangement is stipulated in the Contract.</p> <p>30.7 An order, deletion or change referred to in GC30. 1 shall be in writing, signed by the Departmental Representative and given to the Contractor in accordance with GC11.</p> <p>GC31 INTERPRETATION OF CONTRACT BY DEPARTMENTAL REPRESENTATIVE</p> <p>31.1 If, at any time before the Departmental Representative has issued a Final Certificate of Completion referred to in GC44.1, any question arises between the parties about whether anything has been done as required by the Contract or about what the Contractor is required by the Contract to do, and, in particular but without limiting the generality of the foregoing, about:</p> <p>31.1.1 the meaning of anything in the Plans and Specifications;</p> <p>31.1.2 the meaning to be given to the Plans and Specifications in case of any error therein, omission therefrom, or obscurity or discrepancy in their wording or intention;</p> <p>31.1.3 whether or not the quality or quantity of any material or workmanship supplied or proposed to be supplied by the Contractor meets the requirements of the Contract;</p> <p>31.1.4 the Work and carrying out the Contract are adequate to ensure that the Work will be performed in accordance with the Contract and that the Contract will be carried out in accordance with its terms;</p> <p>31.1.5 what quantity of any kind of Work has been completed by the Contractor; or</p> <p>31.1.6 the timing and scheduling of the various phases of the performance of the Work, the question shall be decided by the Departmental Representative whose decision shall be final and conclusive in respect of the Work.</p> <p>31.2 The Contractor shall perform the Work in accordance with any decisions of the Departmental Representative that are made under GC31.1 and in accordance with any consequential directions given by the Departmental Representative.</p> <p>GC32 WARRANTY AND RECTIFICATION OF DEFECTS IN WORK</p> <p>32.1 Without restricting any warranty or guarantee implied or imposed by law or contained in the contract documents, the Contractor shall, at his own expense:</p> <p>32.1.1 Rectify and make good any defect or fault that</p>	<p>appears in the Work or comes to the attention of the Minister with respect to those parts of the Work accepted in connection with the Interim Certificate of Completion referred to GC44.2 within twelve (12) months from the date of the Interim Certificate of Completion; and</p> <p>32.1.2 Rectify and make good any defect or fault that appears in or comes to the attention of the Minister in connection with those parts of the Work described in the Interim Certificate of Completion referred to in GC44.2 within twelve (12) months from the date of the Final Certificate of Completion referred to in GC44.1.</p> <p>32.2 The Departmental Representative may direct the Contractor to rectify and make good any defect or fault referred to in GC32.1 or covered by any other expressed or implied warranty or guarantee.</p> <p>32.3 A direction referred to in GC32.2 shall be in writing, may include a stipulation in respect of the time within which a defect or fault is required to be rectified and made good by the Contractor, and shall be given to the Contractor in accordance with GC11.</p> <p>32.4 The Contractor shall rectify and make good any defect or fault described in a direction given pursuant to GC32.2 within the time stipulated therein.</p> <p>GC33 NON-COMPLIANCE BY CONTRACTOR</p> <p>33.1 If the Contractor fails to comply with any decision or direction given by the Departmental Representative pursuant to GC18, GC24, GC26, GC31 or GC32, the Departmental Representative may employ such methods as he deems advisable to do that which the Contractor failed to do.</p> <p>33.2 The Contractor shall, on demand, pay Her Majesty an amount that is equal to the aggregate of all costs, expenses and damage incurred or sustained by Her Majesty by reason of the Contractor's failure to comply with any decision or direction referred to in GC33.1, including the cost of any methods employed by the Departmental Representative pursuant to GC33.1.</p> <p>GC34 PROTESTING DEPARTMENTAL REPRESENTATIVE'S DECISIONS</p> <p>34.1 The Contractor may, within ten (10) days after the communication to him of any decision or direction referred to in GC30.3 or GC33.1, protest that decision or direction.</p> <p>34.2 A protest referred to in GC34.1 shall be in writing, contain full reasons for the protest, be signed by the Contractor and be given to Her Majesty by delivery to the Departmental Representative.</p> <p>34.3 If the Contractor gives a protest pursuant to GC34.2, any compliance by the Contractor with the decision or direction that was protested shall not be construed as an admission by the Contractor of the correctness of that decision or direction, or prevent the Contractor from taking whatever action he considers appropriate in the circumstances.</p>
---	---

- 34.4 The giving of a protest by the Contractor pursuant to GC34.2 shall not relieve him from complying with the decision or direction that is the subject of the protest.
- 34.5 Subject to GC34.6, the Contractor shall take any action referred to in GC34.3 within three (3) months after the date that a Final Certificate of Completion is issued under GC44.1, and not afterwards.
- 34.6 The Contractor shall take any action referred to in GC34.3 resulting from a direction under GC32 within three (3) months after the expiry of a warranty or guarantee period and not afterwards.
- 34.7 Subject to GC34.8, if Her Majesty determines that the Contractor's protest is justified, Her Majesty shall pay the Contractor the cost of the additional labour, plant and material necessarily incurred by the Contractor in carrying out the protested decision or direction.
- 34.8 Costs referred to in GC34.7 shall be calculated in accordance with GC48 to GC50.
- GC35 CHANGES IN SOIL CONDITIONS AND NEGLECT OR DELAY BY HER MAJESTY**
- 35.1 Subject to GC35.2 no payment, other than a payment that is expressly stipulated in the contract, shall be made by Her Majesty to the Contractor for any extra expense or any loss or damage incurred or sustained by the Contractor.
- 35.2 If the Contractor incurs or sustains any extra expense or any loss or damage that is directly attributable to:
- 35.2.1 a substantial difference between the information relating to soil conditions at the work site that is contained in the Plans and Specifications or other documents supplied to the Contractor for his use in preparing his tender or a reasonable assumption of fact based thereon made by the Contractor, and the actual soil conditions encountered by the Contractor at the work site during the performance of the Contract; or
- 35.2.2 Any neglect or delay that occurs after the date of the Contract on the part of Her Majesty in providing any information or in doing any act that the Contract either Her Majesty to do or that would ordinarily be done by an owner in accordance with the usage of the trade, he shall, within ten (10) days of the date the actual soil conditions described in GC35.2.1 were encountered or the neglect or delay described in GC35.2.2 occurred, give the Departmental Representative written notice of his intention to claim for that extra expense or that loss or damage.
- 35.3 When the Contractor has given a notice referred to in GC35.2, he shall give the Departmental Representative a written claim for extra expense or loss or damage within thirty (30) days of the date that a Final Certificate of Completion referred to in GC44.1 is issued and not afterwards.
- 35.4 A written claim referred to in GC35.3 shall contain a sufficient description of the facts and circumstances of the occurrence that is the subject of the claim to enable the Departmental Representative to determine whether or not the claim is justified and the Contractor shall supply such further and other information for that purpose as the Departmental Representative requires from time to time.
- 35.5 If the Departmental Representative determines that a claim referred to in GC35.3 is justified, Her Majesty shall make an extra payment to the Contractor in an amount that is calculated in accordance with GC47 to GC50.
- 35.6 If, in the opinion of the Departmental Representative, an occurrence described in GC35.2.1 results in a savings of expenditure by the Contractor in performing the Contract, the amount set out in the Articles of Agreement shall, subject to GC35.7, be reduced by an amount that is equal to the saving.
- 35.7 The amount of the saving referred to in GC35.6 shall be determined in accordance with GC47 to GC49.
- 35.8 If the Contractor fails to give a notice referred to in GC35.2 and a claim referred to in GC35.3 within the times stipulated, an extra payment shall not be made to him in respect of the occurrence.
- GC36 EXTENSION OF TIME**
- 36.1 Subject to GC36.2, the Departmental Representative may, on the application of the Contractor made before the day fixed by the Articles of Agreement for completion of the Work or before any other date previously fixed under this General Condition, extend the time for its completion by fixing a new date if, in the opinion of the Departmental Representative, causes beyond the control of the Contractor have delayed its completion.
- 36.2 An application referred to in GC36.1 shall be accompanied by the written consent of the bonding company whose bond forms part of the contract security.
- GC37 ASSESSMENTS AND DAMAGES FOR LATE COMPLETION**
- 37.1 For the purposes of this General Condition:
- 37.1.1 the Work shall be deemed to be completed on the date that an Interim Certificate of Completion referred to in GC44.2 is issued; and
- 37.1.2 "Period of delay" means the number of days commencing on the day fixed by the Contract for completion of the Work and ending on the day immediately preceding the day on which the Work is completed but does not include any day within a period of extension granted pursuant to GC36. 1, and any other day on which, in the opinion of the Departmental Representative, completion of the Work was delayed for reasons beyond the control of the Contractor.
- 37.2 If the Contractor does not complete the Work by the day fixed for its completion by the Articles of Agreement but completes it thereafter, the

		Contractor's failure to complete the Work.
37.2.1 All salaries, wages and travelling expenses incurred by Her Majesty in respect of persons overseeing the performance of the Work during the period of delay;	38.3	If the whole or any part of the Work that is taken out of the Contractor's hands pursuant to GC38.1 is completed by Her Majesty, the Departmental Representative shall determine the amount, if any, of the holdback or a progress claim that had accrued and was due prior to the date on which the Work was taken out of the Contractor's hands and that is not required for the purposes of having the Work performed or of compensating Her Majesty for any other loss or damage incurred or sustained by reason of the Contractor's default.
37.2.2 The cost incurred by Her Majesty as a result of the inability to use the completed Work for the period of delay; and		38.4 Her Majesty shall pay the Contractor the amount determined not to be required pursuant to GC38.3.
37.2.3 All other expenses and damages incurred or sustained by Her Majesty during the period of delay as a result of the Work not being completed by the day fixed for its completion.		GC39 EFFECT OF TAKING THE WORK OUT OF THE CONTRACTOR'S HANDS
37.3 The Minister may waive the right of Her Majesty to the whole or any part of the amount payable by the Contractor pursuant to GC37.2 if, in the opinion of the Minister, it is in the public interest to do so.	39.1	The taking of the Work or any part thereof out of the Contractor's hands pursuant to GC38 does not operate so as to relieve or discharge him from any obligation under the Contract or imposed upon him by law except the obligation to complete the performance of that part of the Work that was taken out of his hands.
37.3.1 Her Majesty may, without prejudice to any other method of recovery, deduct the amount of such damages from any monies due or become due to the Contractor. The payment or deduction of such damages shall not relieve the Contractor from his obligation to complete the Works, or from any other of his obligations and liabilities under the Contract.	39.2	If the Work or any part thereof is taken out of the Contractor's hands pursuant to GC38, all plant and material and the interest of the Contractor in all real property, licences, powers and privileges acquired, used or provided by the Contractor under the Contract shall continue to be the property of Her Majesty without compensation to the Contractor.
GC38 TAKING THE WORK OUT OF THE CONTRACTOR'S HANDS	39.3	When the Departmental Representative certifies that any plant, material, or any interest of the Contractor referred to in GC39.2 is no longer required for the purposes of the Work, or that it is not in the interests of Her Majesty to retain that plant, material, or interest, it shall revert to the Contractor.
38.1 The Minister may, at his sole discretion, by giving a notice in writing to the Contractor in accordance with GC11, take all or any part of the Work out of the Contractor's hands, and may employ such means as he sees fit to have the Work completed if the Contractor:		GC40 SUSPENSION OF WORK BY MINISTER
38.1.1 Has not, within six (6) days of the Minister or the Departmental Representative giving notice to the Contractor in writing in accordance with GC11, remedied any delay in the commencement or any default in the diligent performance of the Work to the satisfaction of the Departmental Representative;	40.1	The Minister may, when in his opinion it is in the public interest to do so, require the Contractor to suspend performance of the Work either for a specified or an unspecified period by giving a notice of suspension in writing to the Contractor in accordance with GC11.
38.1.2 Has defaulted in the completion of any part of the Work within the time fixed for its completion by the Contract;	40.2	When a notice referred to in GC40.1 is received by the Contractor in accordance with GC11, he shall suspend all operations in respect of the Work except those that, in the opinion of the Departmental Representative, are necessary for the care and preservation of the Work, plant and material.
38.1.3 Has become insolvent;	40.3	The Contractor shall not, during a period of suspension, remove any part of the Work, plant or material from its site without the written consent of the Departmental Representative.
38.1.4 Has committed an act of bankruptcy;	40.4	If a period of suspension is thirty (30) days or less, the Contractor shall, upon the expiration of that period, resume the performance of the Work and he is entitled to be paid the extra cost, calculated in accordance with GC48 to GC50, of any labour, plant and material necessarily incurred by him as a result of the suspension.
38.1.5 Has abandoned the Work;	40.5	If, upon the expiration of a period of suspension of
38.1.6 Has made an assignment of the contract without the consent required by GC3; or		
38.1.7 Has otherwise failed to observe or perform any of the provisions of the Contract.		
38.2 If the whole or any part of the Work is taken out of the Contractor's hands pursuant to GC38.1:		
38.2.1 the Contractor's right to any further payment that is due or accruing under the Contract is, subject only to GC38.4, extinguished; and		
38.2.2 The Contractor is liable to pay Her Majesty, upon demand, an amount that is equal to the amount of all loss and damage incurred or sustained by Her Majesty in respect of the		

	more than thirty (30) days, the Minister and the Contractor agree that the performance of the Work will be continued by the Contractor, the Contractor shall resume performance of the Work subject to any terms and conditions agreed upon by the Minister and the Contractor.		
40.6	If, upon the expiration of a period of suspension of more than thirty (30) days, the Minister and the Contractor do not agree that performance of the Work will be continued by the Contractor or upon the terms and conditions under which the Contractor will continue the Work, the notice of suspension shall be deemed to be a notice of termination pursuant to GC41.		
GC41	TERMINATION OF CONTRACT		
41.1	The Minister may terminate the Contract at any time by giving a notice of termination in writing to the Contractor in accordance with GC11.		
41.2	When a notice referred to in GC41.1 is received by the Contractor in accordance with GC11, he shall, subject to any conditions stipulated in the notice, forthwith cease all operations in performance of the Contract.		
41.3	If the Contract is terminated pursuant to GC41.1, Her Majesty shall pay the Contractor, subject to GC41.4 an amount equal to:		
	41.3.1 the cost to the Contractor of all labour, plant and material supplied by him under the Contract up to the date of termination in respect of a contract or part thereof for which a Unit Price Arrangement is stipulated in the Contract; or the lesser of:		
	41.3.2 An amount, calculated in accordance with the Terms of Payment, that would have been payable to the Contractor had he completed the Work; and		
	41.3.3 An amount that is determined to be due to the Contractor pursuant to GC49 in respect of a contract or part thereof for which a Fixed Price Arrangement is stipulated in the Contract less the aggregate of all amounts that were paid to the Contractor by Her Majesty and all amounts that are due to Her Majesty from the Contractor pursuant to the Contract.		
41.4	If Her Majesty and the Contractor are unable to agree about an amount referred to in GC41.3 that amount shall be determined by the method referred to in GC50.		
GC42	CLAIMS AGAINST AND OBLIGATIONS OF THE CONTRACTOR OR SUBCONTRACTOR		
42.1	Her Majesty may, in order to discharge lawful obligations of and satisfy claims against the Contractor or a Subcontractor arising out of the performance of the Contract, pay any amount that is due and payable to the Contractor pursuant to the Contract directly to the obligees of and the claimants against the Contractor or the Subcontractor but such amount if any, as is paid by Her Majesty shall not exceed that amount which the Contractor would have been obliged to pay to such claimant pursuant to legislation applicable under the governing law of		
		42.2	the Contract. Any such claimant need not comply with the provisions of such legislation setting out the steps by way of notice, registration or otherwise as might have been necessary to preserve or perfect any claim for lien or privilege which claimant might have had, however Her Majesty shall, prior to paying any such claims, provide the Contractor with ten (10) days prior written notice to the effect that She will be so doing.
			Her Majesty will not make any payment as described in GC42.1 unless and until that claimant shall have delivered to Her Majesty:
		42.2.1	A binding and enforceable Judgment or Order of a court of competent jurisdiction setting forth such amount as would have been payable by the Contractor to the claimant pursuant to the provisions of the legislation applicable under the governing law of this Contract;
		42.2.2	A final and enforceable award of an arbitrator setting forth such amount as would have been payable by the Contractor to the claimant pursuant to the provisions of the legislation applicable under the governing law of this Contract; or
		42.2.3	The consent of the Contractor authorizing a payment.
		42.3	For the purposes of determining the entitlement of a claimant pursuant to GC42.2.1 and GC42.2.2, the notice required by GC42.8 shall be deemed to replace the registration or provision of notice after the performance of Work as required by any applicable legislation and no claim shall be deemed to have expired, become void or unenforceable by reason of the claimant not commencing any action within the time prescribed by any applicable legislation.
		42.4	The Contractor shall, by the execution of this Contract, be deemed to have consented to submit to binding arbitration at the request of any claimant those questions that need be answered to establish the entitlement of the claimant to payment pursuant to the provisions of GC42.1 and such arbitration shall have as parties to it any Subcontractor to whom the claimant supplied material, performed Work or rented equipment should such Subcontractor wish to be adjoined and Her Majesty shall not be a party to such arbitration and, subject to any agreement between the Contractor and the claimant to the contrary, the arbitration shall be conducted in accordance with the applicable legislation governing arbitration.
		42.5	A payment made pursuant to GC42.1 is, to the extent of the payment, a discharge of Her Majesty's liability to the Contractor under the Contract and may be deducted from any amount payable to the Contractor under the Contract.
		42.6	The Contractor shall comply with all laws in force in the jurisdiction where the Work is being performed relating to payment period, mandatory holdbacks, and creation and enforcement of mechanics' liens, builder's liens, privileges or similar legislation.
		42.7	The Contractor shall discharge all his lawful obligations and shall satisfy all lawful claims against him arising out of the performance of the Work at

- least as often as the Contract requires Her Majesty to pay the Contractor.
- 42.8** The Contractor shall, whenever requested to do so by the Departmental Representative, make a statutory declaration deposing to the existence and condition of any obligations and claims referred to in GC42.6.
- 42.9** GC42.1 shall only apply to claims and obligations:
- 42.9.1** The notification of which has been received by the Departmental Representative in writing before payment is made to the Contractor pursuant to TP4.10 and within one hundred and twenty (120) days of the date on which the claimant;
- 42.9.1.1** Should have been paid in full under the claimant's contract with the Contractor or Subcontractor where the claim is for money that was lawfully required to be held back from the claimant; or
- 42.9.1.2** Performed the last of the services, Work or labour, or furnished the last of the material pursuant to the claimant's contract with the Contractor or Subcontractor where the claim is not for money referred to in GC42.9.1.1; and
- 42.9.2** The proceedings to determine the right to payment of which, pursuant to GC42.2, shall have commenced within one year from the date that the notice referred to in GC42.9.1 was received by the Departmental Representative, and the notification required by GC42.9.1 shall set forth the amount claimed to be owing and the person who by contract is primarily liable.
- 42.10** Her Majesty may, upon receipt of a notice of claim under GC42.9.1, withhold from any amount that is due and payable to the Contractor pursuant to the Contract the full amount of the claim or any portion thereof.
- 42.11** The Departmental Representative shall notify the Contractor in writing of receipt of any claim referred to in GC42.9.1 and of the intention of Her Majesty to withhold funds pursuant to GC42.10 and the Contractor may, at any time thereafter and until payment is made to the claimant, be entitled to post, with Her Majesty, security in a form acceptable to Her Majesty in an amount equal to the value of the claim, the notice of which is received by the Departmental Representative and upon receipt of such security Her Majesty shall release to the Contractor any funds which would be otherwise payable to the Contractor, that were withheld pursuant to the provisions of GC42.10 in respect of the claim of any claimant for whom the security stands.
- GC43 SECURITY DEPOSIT - FORFEITURE OR RETURN**
- 43.1** If:
- 43.1.1** The Work is taken out of the Contractor's hands pursuant to GC38;
- 43.1.2** The Contract is terminated pursuant to GC41; or
- 43.1.3** The Contractor is in breach of or in default
- under the Contract;
- 43.2** Her Majesty may convert the security deposit, if any, to Her own use.
- 43.3** If Her Majesty converts the contract security pursuant to GC43.1, the amount realized shall be deemed to be an amount due from Her Majesty to the Contractor under the Contract.
- 43.4** Any balance of an amount referred to in GC43.3 that remains after payment of all losses, damage and claims of Her Majesty and others shall be paid by Her Majesty to the Contractor if, in the opinion of the Departmental Representative, it is not required for the purposes of the Contract.
- GC44 DEPARTMENTAL REPRESENTATIVE'S CERTIFICATES**
- 44.1** On the date that:
- 44.1.1** the Work has been completed; and
- 44.1.2** The Contractor has complied with the Contract and all orders and directions made pursuant thereto, both to the satisfaction of the Departmental Representative, the Departmental Representative shall issue a Final Certificate of Completion to the Contractor.
- 44.2** If the Departmental Representative is satisfied that the Work is substantially complete he shall, at any time before he issues a certificate referred to in GC44.1, issue an Interim Certificate of Completion to the Contractor, and for the purposes of GC44.2 the Work will be considered to be substantially complete:
- 44.2.1** When the Work under the Contract or a substantial part thereof is, in the opinion of the Departmental Representative, ready for use by Her Majesty or is being used for the purposes intended; and
- 44.2.2** when the Work remaining to be done under the Contract is, in the opinion of the Departmental Representative, capable of completion or correction at a cost of not more than:
- 44.2.2.1** Three percent (3%) of the first \$500,000;
- 44.2.2.2** Two percent (2%) of the next \$500,000, and
- 44.2.2.3** One percent (1%) of the balance of the value of the Contract at the time this cost is calculated.
- 44.3** For the sole purpose of GC44.2.2, where the Work or a substantial part thereof is ready for use or is being used for the purposes intended and the remainder of the Work or a part thereof cannot be completed by the time specified in C3, or as amended pursuant to GC36, for reasons beyond the control of the Contractor or where the Departmental Representative and the Contractor agree in writing not to complete a part of the Work within the specified time, the cost of that part of the Work which was either beyond the control of the Contractor to complete or the Departmental Representative and the Contractor have agreed in writing not to complete by the time specified shall

<p>be deducted from the value of the Contract referred to GC44.2.2 and the said cost shall not form part of the cost of the Work remaining to be done in determining substantial completion.</p> <p>44.4 An Interim Certificate of Completion referred to in GC44.2 shall describe the parts of the Work not completed to the satisfaction of the Departmental Representative and all things that must be done by the Contractor:</p> <p>44.4.1 before a Final Certificate of Completion referred to in GC44.1 will be issued; and</p> <p>44.4.2 Before the twelve (12) month period referred to in GC32.1.2. shall commence for the said parts and all the said things.</p> <p>44.5 The Departmental Representative may, in addition to the parts of the Work described in an Interim Certificate of Completion referred to in GC44.2, require the Contractor to rectify any other parts of the Work not completed to his satisfaction and to do any other things that are necessary for the satisfactory completion of the Work.</p> <p>44.6 If the Contract or a part thereof is subject to a Unit Price Arrangement, the Departmental Representative shall measure and record the quantities of labour, plant and material, performed, used and supplied by the Contractor in performing the Work and shall, at the request of the Contractor, inform him of those measurements.</p> <p>44.7 The Contractor shall assist and cooperate with the Departmental Representative in the performance of his duties referred to in GC44.6 and shall be entitled to inspect any record made by the Departmental Representative pursuant to GC44.6.</p> <p>44.8 After the Departmental Representative has issued a Final Certificate of Completion referred to in GC44.1, he shall, if GC44.6 applies, issue a Final Certificate of Measurement.</p> <p>44.9 A Final Certificate of Measurement referred to in GC44.8 shall:</p> <p>44.9.1 contain the aggregate of all measurements of quantities referred to in GC44.6; and</p> <p>44.9.2 Be binding upon and conclusive between Her Majesty and the Contractor as to the quantities referred to therein.</p> <p>GC45 RETURN OF SECURITY DEPOSIT</p> <p>45.1 After an Interim Certificate of Completion referred to in GC44.2 has been issued, Her Majesty shall, if the Contractor is not in breach of or in default under the Contract, return to the Contractor all or any part of the security deposit that, in the opinion of the Departmental Representative, is not required for the purposes of the Contract.</p> <p>45.2 After a Final Certificate of Completion referred to in GC44.1 has been issued, Her Majesty shall return to the Contractor the remainder of any security deposit unless the Contract stipulates otherwise.</p> <p>45.3 If the security deposit was paid into the Consolidated Revenue Fund of Canada, Her Majesty shall pay interest thereon to the Contractor at a rate established from time to time pursuant to section 21(2) of Canada's Financial Administration Act.</p>	<p>GC46 CLARIFICATION OF TERMS IN GC47 TO GC50</p> <p>46.1 For the purposes of GC47 to GC50:</p> <p>46.1.1 "Unit Price Table" means the table set out in the Contract; and</p> <p>46.1.2 "Plant" does not include tools customarily provided by a tradesman in practising his trade.</p> <p>GC47 ADDITIONS OR AMENDMENTS TO UNIT PRICE TABLE</p> <p>47.1 Where a Unit Price Arrangement applies to the Contract or a part thereof the Departmental Representative and the Contractor may, by an agreement in writing:</p> <p>47.1.1 Add classes of labour, plant or material, and units of measurement, prices per unit and estimated quantities to the Unit Price Table if any labour, plant or material that is to be included in the Final Certificate of Measurement referred to in GC44.8 is not included in any class of labour, plant or material set out in the Unit Price Table; or</p> <p>47.1.2 subject to GC47.2 and GC47.3, amend a price per unit set out in the Unit Price Table for any class of labour, plant or material included therein if the Final Certificate of Measurement referred to in GC44.8 shows or is expected to show that the total quantity of that class of labour, plant or material actually, used or supplied by the Contractor in performing the Work is:</p> <p>47.1.2.1 Less than eighty-five percent (85%) of that estimated total quantity; or</p> <p>47.1.2.2 In excess of one hundred and fifteen percent (115%) of that estimated total quantity.</p> <p>47.2 In no event shall the total cost of an item set out in the Unit Price Table that has been amended pursuant to GC47.1.2.1. exceed the amount that would have been payable to the Contractor had the estimated total quantity actually been performed, used or supplied.</p> <p>47.3 An amendment that is made necessary by GC47.1.2.2 shall apply only to the quantities that are in excess of one hundred and fifteen percent (115%).</p> <p>47.4 If the Departmental Representative and the Contractor do not agree as contemplated in GC47.1, the Departmental Representative shall determine the class and the unit of measurement of the labour, plant or material and, subject to GC47.2 and GC47.3, the price per unit therefor shall be determined in accordance with GC50.</p> <p>GC48 DETERMINATION OF COST - UNIT PRICE TABLE</p> <p>Whenever, for the purposes of the Contract it is necessary to determine the cost of labour, plant or material, it shall be determined by multiplying the quantity of that labour, plant or material expressed in the Unit Price Table by the price of that unit set out by agreement in a unit price table which will be included in the Contract prior to signing.</p>
---	--

GC49 DETERMINATION OF COST - NEGOTIATION

49.1 If the method described in GC48 cannot be used because the labour, plant or material is of a kind or class that is not set out in the Unit Price Table, the cost of that labour, plant or material for the purposes of the Contract shall be the amount agreed upon from time to time by the Contractor and the Departmental Representative.

49.2 For the purposes of GC49.1, the Contractor shall submit to the Departmental Representative any necessary cost information requested by the Departmental Representative in respect of the labour, plant and material referred to in GC49.1.

GC50 DETERMINATION OF COST - FAILING NEGOTIATION

50.1 If the methods described in GC47, GC48 or GC49 fail for any reason to achieve a determination of the cost of labour, plant and material for the purposes referred to therein, that cost shall be equal to the aggregate of:

50.1.1 all reasonable and proper amounts actually expended or legally payable by the Contractor in respect of the labour, plant and material that falls within one of the classes of expenditure described in GC50.2 that are directly attributable to the performance of the Contract;

50.1.2 an allowance for profit and all other expenditures or costs, including overhead, general administration costs, financing and interest charges, and every other cost, charge and expenses, but not including those referred to in GC50.1.1 or GC50.1.3 or of a class referred to in GC50.2, in an amount that is equal to ten percent (10%) of the sum of the expenses referred to in GC50.1.1, and interest on the costs determined under GC50.1.1 and GC50.1.3, which interest shall be calculated in accordance with TP9.

50.1.3 provided that the total cost of an item set out in the Unit Price Table that is subject to the provisions of GC47.1.2 does not exceed the amount that would have been payable to the Contractor had the estimated total quantity of the said item actually been performed, used or supplied.

50.2 For purposes of GC50.1.1, the classes of expenditure that may be taken into account in determining the cost of labour, plant and material are:

50.2.1 Payments to subcontractors;

50.2.2 Wages, salaries and travelling expenses of employees of the Contractor while they are actually and properly engaged on the Work, other than wages, salaries, bonuses, living and travelling expenses of personnel of the Contractor generally employed at the head office or at a general office of the Contractor unless they are engaged at the work site with the approval of the Departmental

Representative;

50.2.3 Assessments payable under any statutory authority relating to workmen's compensation, employment insurance, pension plan or holidays with pay;

50.2.4 Rent that is paid for plant or an amount equivalent to the said rent if the plant is owned by the Contractor that is necessary for and used in the performance of the Work, if the rent or the equivalent amount is reasonable and use of that plant has been approved by the Departmental Representative;

50.2.5 Payments for maintaining and operating plant necessary for and used in the performance of the Work, and payments for effecting such repairs thereto as, in the opinion of the Departmental Representative, are necessary to the proper performance of the Contract other than payments for any repairs to the plant arising out of defects existing before its allocation to the Work;

50.2.6 Payments for material that is necessary for and incorporated in the Work, or that is necessary for and consumed in the performance of the Contract;

50.2.7 Payments for preparation, delivery, handling, erection, installation, inspection, protection and removal of the plant and material necessary for and used in the performance of the Contract; and

50.3 Any other payments made by the Contractor with the written approval of the Departmental Representative that are necessary for the performance of the Contract.

GC51 RECORDS TO BE KEPT BY CONTRACTOR

51.1 The Contractor shall:

51.1.1 Maintain full records of his estimated and actual cost of the Work together with all tender calls, quotations, contracts, correspondence, invoices, receipts and vouchers relating thereto;

51.1.2 Make all records and material referred to in GC51.1.1 available to audit and inspection by the Minister and the Deputy Receiver General for Canada or by persons acting on behalf of either or both of them, when requested;

51.1.3 Allow any of the persons referred to in GC51.1.2 to make copies of and to take extracts from any of the records and material referred to in GC51.1.1; and

51.1.4 Furnish any person referred to in GC51.1.2 with any information he may require from time to time in connection with such records and material.

51.2 The records maintained by the Contractor pursuant to GC51.1.1 shall be kept intact by the Contractor until the expiration of two (2) years after the date that a Final Certificate of Completion referred to in GC44.1 was issued or until the expiration of such other period of time as the Minister may direct.

51.3 The Contractor shall cause all subcontractors and all

	other persons directly or indirectly controlled by or affiliated with the Contractor and all persons directly or indirectly having control of the Contractor to comply with GC51.1 and GC51.2 as if they were the Contractor.		
GC52	CONFLICT OF INTEREST It is a term of this Contract that no former public office holder who is not in compliance with the Government of Canada's Conflict of Interest and Post-Employment Code for Public Office Holders shall derive a direct benefit from this Contract.		
GC53	CONTRACTOR STATUS		
53.1	The Contractor shall be engaged under the contract as an independent Contractor.		
53.2	The Contractor or any employee of the said Contractor is not engaged by the Contract as an employee, servant or agent of Her Majesty.		
53.3	For the purposes of GC53.1 and GC53.2 the Contractor shall be solely responsible for any and all payments and deductions required to be made by law including those required for pension plans, employment insurance, workers' compensation or income tax.		
GC54	GOVERNING LAWS The Contract shall be governed by the laws in force in the jurisdiction defined in section C14 of the Articles of Agreement.		
GC55	SOVEREIGN IMMUNITY Notwithstanding any provision in this Contract, Her Majesty the Queen in Right of Canada, does not waive any immunity to which she is or may be entitled to by virtue of domestic or international law.		
GC56	HUMAN REMAINS, ARCHAEOLOGICAL REMAINS AND ITEMS OF HISTORICAL OR SCIENTIFIC INTEREST		
56.1	For the purposes of this clause:		
56.1.1	Human remains means the whole or any part of a deceased human being, irrespective of the time that has elapsed since death;		
56.1.2	Archaeological remains are items, artefacts or things made, modified or used by human beings in antiquity and may include, but not are limited to, stone, wood, or iron structures; monuments, bump deposits, bone artifacts, weapons, tools, coins, or pottery; and		
56.1.3	Items of historical or scientific interest are naturally occurring or manufactured objects or things of any age that are not archaeological remains but may be of interest to society because of their historical or scientific significance, value, rarity, natural beauty, or other quality.		
56.2	If, during the course of the Work, the Contractor encounters any object, item or thing which is described in clause GC56.1, or which resembles any object, item or thing described in clause GC56.1, the Contractor shall:		
		56.2.1	take all reasonable steps, including immediately stopping the Work in the affected area, to protect and preserve the object, item or thing;
		56.2.2	immediately notify the Departmental Representative of the circumstances in writing; and
		56.2.3	Take all reasonable steps to minimize additional costs which may accrue as a result of any work stoppage.
		56.3	Upon receipt of a notification in accordance with GC56.2.2, the Departmental Representative shall, in a timely manner, determine whether the object, item, or things is one described in, or contemplated by, clause GC56.1, and shall notify the Contractor in writing of any action to be performed, or Work to be carried out, by the Contractor as a result of the Departmental Representative's determination.
		56.4	The Departmental Representative may, at any time, enlist the services of experts, particularly an archaeologist or historian as appropriate, to assist in the investigation, examination, taking of measurements or other such recordings, placing of permanent protection around or removing of the object, item or thing encountered by the Contractor, and monitoring in case of further discoveries, and the Contractor shall, to the satisfaction of the Departmental Representative, allow them access and cooperate with them in the carrying out of their duties and obligations.
		56.5	Human remains, archaeological remains and items of historical or scientific interest encountered at the site of the Work shall remain the property of her Majesty.
		56.6	Accept as may be otherwise provided for in the contract, the provisions of GC30 shall apply.
		GC57	CONTAMINATED SITE CONDITIONS
		57.1	For the purposes of this clause, a contaminated site condition exists when toxic, radioactive or other hazardous substances or materials, or other pollutants, are found to be present at the site of the Work to the extent that they constitute a hazard, or potential hazard, to the environment, property, or the health or safety of any person.
		57.2	If the Contractor encounters a contaminated site condition, or has reasonable grounds to believe that a contaminated site condition exists at the site of the Work, the Contractor shall:
		57.2.1	take all reasonable steps, including stopping the Work, to ensure that no person suffers injury, sickness or death, and that neither property nor the environment is injured or destroyed as a result of the contaminated site condition;
		57.2.2	immediately notify the Departmental Representative of the circumstances in writing; and
		57.2.3	Take all reasonable steps to minimize additional costs which may accrue as a result of any work stoppage.
		57.3	Upon receipt of a notification in accordance with GC57.2.2, the Departmental Representative shall, in a timely manner, determine whether a contaminated site condition as described in, or contemplated by,

- clause GC57.1, exists, and shall notify the Contractor in writing of any action to be taken, or Work to be performed, by the Contractor as a result of the Departmental Representatives determination.
- 57.4 If the Contractor's services are required by the Departmental Representative, the Contractor shall follow the direction of the Departmental Representative with regard to any excavation, treatment and disposal of the contaminated substances or materials.
- 57.5 The Departmental Representative may at any time, and at the Departmental Representative's sole discretion, enlist the services of experts and specialty contractors to assist in determining the existence of, and the extent and treatment of the contaminated site condition, and the Contractor shall, to the satisfaction of the Departmental Representative, allow them access and cooperate with them in the carrying out of their duties and obligations.
- 57.6 Accept as may be otherwise provided for in the Contract, the provisions of GC30 shall apply.

GC58 CERTIFICATION - CONTINGENCY FEES

- 58.1 The Contractor certifies that it has not directly or indirectly paid or agreed to pay and covenants that it will not directly or indirectly pay or agree to pay a contingency fee for the solicitation, negotiation or obtaining of this Contract to any person other than an employee acting in the normal course of the employee's duties.
- 58.2 All accounts and records pertaining to payments of fees or other compensation for the solicitation, obtaining or negotiation of the Contract shall be subject to the accounts and audit provisions of the Contract.
- 58.3 If the Contractor certifies falsely under GC58.1 or is in default of the obligations contained therein, Her Majesty may either take the Work out of the Contractor's hands in accordance with the provisions of the Contract to recover from the Contractor by way of reduction to the Contract amount or otherwise the full amount of the contingency fee.
- 58.4 For the purposes of GC58:
- 58.4.1 "Contingency fee" means any payment or other compensation that is contingent upon or is calculated upon the basis of a degree of success in soliciting or obtaining a Government contract or negotiation the whole or any part of its terms;
- 58.4.2 "Employee" means a person with whom the Contractor has an employer/employee relationship; and
- 58.4.3 "Person" includes an individual or a group of individuals, a corporation, a partnership, an organization and an association and, without restricting the generality of the foregoing, includes any individual who is required to file a return with the registrar pursuant to section 5 of the Lobbyist Registration Act R.S. 1985 c.44 (4th Supplement) as the same may be amended from time to time.

GC59 DISPUTE SETTLEMENT

59.1 Mutual Discussions

The Contractor and Her Majesty, which for the purpose of this GC 59.1 shall jointly be referred to as the "Parties" and severally as the "Party," agree that if any dispute arises out of or in connection with this Contract, including without limitation any question regarding its existence, validity, termination of rights or obligation of any party, the Parties shall attempt, for a period of thirty (30) days after receipt by one Party of a notice from the other Party of indicating:

- 59.1.1 the existence of the dispute
- 59.1.2 its basic substance; and
- 59.1.3 The other Party's decision to refer the dispute to arbitration in accordance with GC59 of the Contract, the Parties shall attempt to settle the dispute by mutual discussions between them.

59.2 Referral to Arbitration

Any such dispute that cannot be settled amicably by mutual discussion within the thirty (30) day period referred to above, shall be settled by arbitration under the arbitration of the Province of Ontario (the "Rules"). The venue of the arbitration shall be conducted in the province of Ontario, Canada. Any notice of arbitration, response or other communication given to or by a party to the arbitration shall be given and deemed received as provided in the Rules. The costs of the arbitration shall be determined and paid by the parties to the arbitration as provided in the Rules.

59.3 Appointments of Arbitrators

Each of the Parties has the right to appoint one (1) arbitrator. The two (2) arbitrators will in turn appoint the third arbitrator. Should either Party fail to appoint its respective arbitrator within thirty (30) days from the date requested by the other Party, or should the two (2) arbitrators so appointed fail to appoint the third arbitrator within thirty (30) days from the date of appointment of the second arbitrator then such arbitrator(s) shall be appointed by the chairman of the Attribution of the Association of Chartered Engineers in the Province of Ontario, Canada.

59.4 No Legal Proceedings

Each Party agrees that it will not institute any legal proceedings arising out of or in connection with this Contract, except only as provided in this GC34 and each party agrees that it will apply to the court having jurisdiction to homologate for legal enforcement the decision rendered by the arbitral tribunal. In the event any legal proceedings are instituted in any court to enforce any arbitration award, the person or persons against whom enforcement of that arbitration award is sought shall pay all costs, including without limitation the costs of legal counsel and translation fees, of the person or persons seeking to enforce the arbitration award.

59.5 Award Binding

The arbitration must be held within six (6) months of the date of appointment of the arbitrator and the

- arbitrator is authorized to assess costs against a party who has caused delay or who has failed to comply with any rules of the arbitration. The decision of the arbitrator shall be final, binding and incontestable and may be used as a basis for judgement thereon in the Province of Ontario, Canada, or elsewhere.
- 59.6 Waivers**
The Parties expressly agree to waive Article 48.1 of Law No. 30 Year 1999 on Arbitration and Alternative Dispute Resolution, so that the mandate of the arbitrators duly constituted in accordance with the terms of this Contract shall remain in effect until a final arbitration award has been issued by the arbitrators.
- 59.7 Enforcement of Awards**
For the purpose of enforcing any arbitration award, the Parties choose the general, permanent and not-exclusive domicile of the Office of the Registrar of the Province of Ontario, Canada, without prejudice to the Parties' rights to enforce any arbitration award in any court having jurisdiction over the other Party or its assets.
- GC60 FORCE MAJEURE**
- 60.1 Relief from Performance**
Neither Her Majesty nor the Contractor shall be liable to the other for any delay in or failure to render, any act or thing to be performed pursuant to this Contract, to the extent that such delay or failure is caused by an event of force majeure. The effected party must use its best endeavours to eliminate the effects of the force majeure as soon as possible and resume performance hereunder.
- 60.2 No termination**
This Contract must not be terminated by temporary force majeure and the rights and obligations of the Contractor and Her Majesty must be restored in full after any period of force majeure has ended.
- 60.3 Payment of Moneys**
- 60.3.1** If as a consequence of money that is required to be paid by one Party pursuant to the terms and conditions of this Contract cannot be so paid in the manner directed by this Contract due to an event of force majeure, then the Party required to pay must notify the Party entitled to receive the money of the former's inability to pay and the reasons for it.
- 60.3.2** The Party entitled to receive the money will designate to the Party required to pay an alternative place for payment and the latter will remit the funds to that place for the Party entitled to receive the funds.
- 60.4 Force Majeure Events**
Force majeure events shall include, without limitation, any act of God, civil commotion or delays caused by governmental restriction affecting all or any portion of the Work which prevents or materially restricts either party from performing its obligations hereunder for which such party is responsible
- GC61 HEALTH AND SAFETY**
- 61.1** The Contractor shall ensure, in fulfilling its contractual obligations under this Contract, that its employees and agents are appropriately equipped with all safety clothing and equipment required to perform the Work.
- 61.2** The Contractor shall further ensure that its employees and agents adhere to and follow all applicable health and safety regulations, standards and procedures in force in the jurisdiction and have been trained and will use all mandatory safety equipment imposed by local law when completing the Work under this Contract.

SECTION "IV" – INSURANCE CONDITIONS**IC1 PROOF OF INSURANCE**

- 1.1** The Contractor shall, at its own expense, obtain and maintain insurance as provided hereunder with companies subject to approval in writing by Her Majesty.
- 1.2** Immediately following notification of Contract award and preceding the start of any on-site Work, the Contractor shall have its insurance broker, agency or underwriter inform the Departmental Representative in writing that all insurance required hereunder is in force.
- 1.3** Within thirty (30) days after acceptance of the Contractor's tender, the Contractor shall, unless otherwise directed in writing by the Departmental Representative, deposit with the Departmental Representative an Insurer's Certificate of Insurance in the form displayed in this document and, if requested by the Departmental Representative, the originals or certified true copies of all contracts of insurance maintained by the Contractor pursuant to the Insurance Coverage Requirements shown hereunder.

IC2 RISK MANAGEMENT

- 2.1** The provisions of the Insurance Coverage Requirements contained hereunder are not intended to cover all of the Contractor's obligations under GC8 of the General Conditions Section "III" of the Contract. Any additional risk management measures or additional insurance coverages the Contractor may deem necessary to fulfill its obligations under GC8 shall be at its own discretion and expense.

IC3 PAYMENT OF DEDUCTIBLE

- 3.1** The payment of monies up to the deductible amount made in satisfaction of a claim shall be borne by the Contractor.

IC4 TYPES OF INSURANCE REQUIRED

- 4.1** The Contractor will obtain the following types of commercial insurance coverage:
- 4.1.1** Comprehensive General Liability Insurance ("CGL"); and
 - 4.1.2** Builder's Risk - Direct Damage Insurance ("BR").

IC5 ADDITIONAL NAMED INSURED

- 5.1** Each insurance policy shall insure the Contractor, and shall include as Additional Named Insured, the Owner, being Her Majesty the Queen in right of Canada, represented by the Minister of Foreign Affairs and the Employees or servants of both Her Majesty and the Contractor.

IC6 PERIOD OF INSURANCE COVERAGE

- 6.1** Unless otherwise directed in writing by the Departmental Representative, the policies required hereunder shall attach from the date of contract award and shall be maintained until the day of issue of the Final Certificate of Completion.

IC7 NOTIFICATION

- 7.1** Each insurance policy shall contain a provision that thirty (30) days prior written notice shall be given by the Insurer to the Departmental Representative in the event of any material change in, cancellation of, or expiration of coverage. Any notice affecting a material change in, cancellation of, or expiration of coverage received by the Contractor shall be transmitted forthwith to the Departmental Representative.

PART I - COMPREHENSIVE GENERAL LIABILITY (CGL)**CGL1 LIMITS**

- 1.1 The policy shall be written on a form similar to that known and referred to in the insurance industry as IBC 2100 - Commercial General Liability policy (Occurrence form) and shall provide for limit of liability of not less than the amount stated in C9, inclusive of Bodily Injury and Property Damage for any one occurrence or series of occurrences arising out of one cause. Legal or defence costs incurred in respect of a claim or claims shall not operate to decrease the limit of liability.

CGL2 COVERAGES

- 2.1 The policy shall include but not necessarily be limited to the following coverages:
- 2.1.1 All premises, property and operations necessary or incidental to the performance of this Contract;
 - 2.1.2 Personal injury;
 - 2.1.3 Bodily injury and Property Damage on an "occurrence" basis;
 - 2.1.4 "Broad Form" Property Damage including the loss of use of property;
 - 2.1.5 Removal or weakening of support of any property, building or land whether such support be natural or otherwise;
 - 2.1.6 Elevator Liability (including Escalators, Hoists and Similar Devices);
 - 2.1.7 Contingent Employer's Liability;
 - 2.1.8 Owner's and Contractor's Protective Liability;
 - 2.1.9 Contractual and Assumed Liabilities under this Contract;
 - 2.1.10 Completed Operations and Products Liability;
The insurance shall continue for a period of at least two (2) years beyond the date of the Departmental Representative's Final Certificate of Completion for the Completed Operations Hazard.
 - 2.1.11 Cross Liability;
The clause shall be written as follows:
Cross Liability
The insurance as is afforded by this policy shall apply in respect to any claim or action brought against any one Insured by any other Insured. The coverage shall apply in the same manner and to the same extent as though a separate policy had been issued to each Insured. The inclusion herein of more than one Insured shall not operate to increase the limit of the Insurer's liability.
 - 2.1.12 Severability of Interests Clause;
The clause shall be written as follows:
Severability of Interests
This policy, subject to the limits of liability stated herein, shall apply separately to each Insured in the same manner and to the same extent as it a separate policy had been issued to each. This inclusion herein of more than one insured shall not increase the limit of the Insurer's liability.
- 2.2 Period of Insurance Coverage:
The period of required insurance coverage for all insurance elements listed in CGL2: Coverages shall be from the date of execution of this contract until the date of issuance by the Departmental Representative of the Final Certificate of Completion.

CGL3 ADDITIONAL EXPOSURES

- 3.1 The policy shall be endorsed to include the following exposures or hazards if the Work is subject thereto:
- 3.1.1 Blasting;
 - 3.1.2 Pile driving and caisson work;
 - 3.1.3 Underpinning;
 - 3.1.4 Risks associated with the activities of the contractor on an active airport;
 - 3.1.5 Radioactive contamination resulting from the use of commercial isotopes; and

- 3.1.6 Damage to the portion of an existing building beyond that directly associated with an addition, renovation or installation contract. (The care, custody and control exclusion shall not apply).

CGL4 INSURANCE PROCEEDS

- 4.1 Insurance Proceeds from this policy are payable directly to a Claimant/Third Party.

CGL5 DEDUCTIBLE

- 5.1 The policy shall be issued with a deductible amount of not more than \$500.00 per occurrence applying to Property Damage claims only.

PART II - BUILDER'S RISK - DIRECT DAMAGE (BR)**BR1 SCOPE OF POLICY**

- 1.1 The policy shall be written on an "All Risks" basis granting coverage similar to that provided by the form known and referred to in the Insurance Industry as "Builders' Risk Comprehensive Form."

BR2 PROPERTY INSURED

- 2.1 The property insured shall include:
- 2.1.1 The Work and all property, equipment and materials intended to become part of the finished Work at the site of the project while awaiting, during and after installation, erection or construction including testing;
 - 2.1.2 Expenses incurred in the removal from the construction site of debris of the property insured, including demolition of damaged property, de-icing and de-watering, occasioned by loss, destruction or damage to such property and in respect of which insurance is provided by this policy; and
 - 2.1.3 Equipment and materials required for the execution or temporary protection of the Work.

BR3 INSURANCE PROCEEDS

- 3.1 Insurance Proceeds from this policy are payable in accordance with GC28 of the General Conditions of the Contract.
- 3.2 The policy shall provide that the proceeds thereof are payable to Her Majesty or as the Minister may direct.
- 3.3 The Contractor shall do such things and execute such documents as are necessary to effect payment of the proceeds.

BR4 AMOUNT OF INSURANCE

- 4.1 The amount of insurance shall not be less than the sum of the contract value plus the declared value (if any) set forth in the contract documents of all material and equipment supplied by Her Majesty at the site of the project to be incorporated into and to form part of the finished Work.

BR5 DEDUCTIBLE

- 5.1 The policy shall be issued with a deductible amount of not more than \$1,000.00 CAD.

BR6 EXCLUSION QUALIFICATIONS

- 6.1 The policy may be subject to the standard exclusions but the following qualifications shall apply:
- 6.1.1 Faulty materials, workmanship or design may be excluded only to the extent of the cost of making good thereof and shall not apply to loss or damage resulting therefrom;
 - 6.1.2 Loss or damage caused by contamination by radioactive material may be excluded except for loss or damage resulting from commercial isotopes used for industrial measurement, inspection, quality control, radiographic or photographic use; and
 - 6.1.3 Use and occupancy of the project or any part or section thereof shall be permitted where such is for the purposes for which the project is intended upon completion.

BROKER'S CERTIFICATE OF INSURANCE

(TO BE DELIVERED TO THE DEPARTMENTAL REPRESENTATIVE BEFORE THE
START OF ANY ON-SITE WORK)

COVERING:

DESCRIPTION OF WORK: _____

LOCATION OF WORK: _____

ISSUED BY:

BROKER/AGENT: _____

ADDRESS: _____

ISSUED TO: FOREIGN AFFAIRS, TRADE AND DEVELOPMENT CANADA

ADDRESS: 125 SUSSEX DRIVE, OTTAWA, ONTARIO CANADA K1A 0G2

NAMED INSURED:

CONTRACTOR: _____

ADDRESS: _____

This document certifies that the following policies of Insurance are at present in force covering all operations of the Insured, effective from _____ 20__ in connection with Foreign Affairs, Trade and Development Canada, for the _____ made between the Named Insured and Foreign Affairs, Trade and Development Canada.

TYPE	POLICY NUMBER	EXPIRY DATE OF LIABILITY			LIMITS	DEDUCTIBLE
		DAY	MONTH	YEAR		
Comprehensive General Liability						
Builder's Risk "All Risks"						

Each of these policies provides coverages as specified in Insurance Conditions Section "IV" which form part of this Contract.

The Insurer agrees to notify Her Majesty and the Named Insured in writing thirty (30) days prior to any material change in, cancellation of, or expiration of any policy or coverage.

Name - Broker/Agent's
Authorized Representative

Signature-Broker/Agent's
Authorized Representative

Date

Telephone Number

ISSUANCE OF THIS CERTIFICATE SHALL NOT LIMIT OR RESTRICT THE RIGHT OF HER MAJESTY TO REQUEST AT ANY TIME DUPLICATE CERTIFIED COPIES OF SAID INSURANCE POLICIES.

INSURER'S CERTIFICATE OF INSURANCE

(TO BE DELIVERED TO THE DEPARTMENTAL REPRESENTATIVE BEFORE THE
START OF ANY ON-SITE WORK)

COVERING:

DESCRIPTION OF WORK: _____

LOCATION OF WORK: _____

ISSUED BY:

BROKER/AGENT: _____

ADDRESS: _____

ISSUED TO: FOREIGN AFFAIRS, TRADE AND DEVELOPMENT CANADA

ADDRESS: 125 SUSSEX DRIVE, OTTAWA, ONTARIO CANADA K1A 0G2

NAMED INSURED:

CONTRACTOR: _____

ADDRESS: _____

This document certifies that the following policies of Insurance are at present in force covering all operations of the Insured, effective from _____ 20__ in connection Foreign Affairs, Trade and Development Canada, for the _____ made between the Named Insured and Foreign Affairs, Trade and Development Canada.

TYPE	POLICY NUMBER	EXPIRY DATE OF LIABILITY			LIMITS	DEDUCTIBLE
		DAY	MONTH	YEAR		
Comprehensive General Liability						
Builder's Risk "All Risks"						

Each of these policies provides coverages as specified in Insurance Conditions Section "IV" which form part of this Contract.

The Insurer agrees to notify Her Majesty and the Named Insured in writing thirty (30) days prior to any material change in, cancellation of, or expiration of any policy or coverage.

Name - Insurer's
Authorized Representative

Signature- Insurer's
Authorized Representative

Date

Telephone Number

ISSUANCE OF THIS CERTIFICATE SHALL NOT LIMIT OR RESTRICT THE RIGHT OF HER MAJESTY TO REQUEST AT ANY TIME DUPLICATE CERTIFIED COPIES OF SAID INSURANCE POLICIES.

SECTION “V” – CONTRACT SECURITY CONDITIONS**CS1 OBLIGATION TO PROVIDE CONTRACT SECURITY**

- 1.1** Where the contract amount referred to in the Contract is:
- 1.1.1** less than CDN \$25,000.00, the Departmental Representative may require the Contractor to provide contract security prescribed in CS2; and
 - 1.1.2** CDN \$25,000.00 or more, the Contractor shall, at his own expense, provide one or more of the forms of contract security prescribed in CS2.
- 1.2** The Contractor is required to provide contract security pursuant to CS2 and such security shall be delivered to the Departmental Representative within fourteen (14) days after the date that the Contractor receives notice that his tender or offer was accepted by Her Majesty.

CS2 DESCRIPTION OF ACCEPTABLE CONTRACT SECURITY

- 2.1** If the Contractor is required to provide contract security pursuant to CS1, Her Majesty shall accept from the Contractor one or more of the forms of security prescribed in CS2.2 to CS2.6.
- 2.2** A Contractor shall deliver to the Departmental Representative:
- 2.2.1** a performance bond and a labour and material payment bond each in an amount that is equal to not less than the amount stated in C10 of the Articles of Agreement; or
 - 2.2.2** a labour and material payment bond in an amount that is equal to not less than the amount stated in C9 of the Articles of Agreement, and a security deposit in an amount that is equal to:
 - 2.2.2.1** not less than 10% of the contract amount referred to in the Articles of Agreement where that amount does not exceed CDN \$250,000.00; or
 - 2.2.2.2** CDN \$25,000.00 plus 5% of the part of the contract amount referred to in the Articles of Agreement that exceeds CDN \$250,000.00; or
 - 2.2.2.3** a security deposit in an amount prescribed by CS2.2.2 plus an additional amount that is equal to 10% of the contract amount referred to in the Articles of Agreement.
- 2.3** A performance bond and a labour and material payment bond referred to in CS2.2 shall be in a form and be issued by a bonding or surety company that is approved by Her Majesty.
- 2.4** The amount of a security deposit referred to in CS2.2.2 shall not exceed CDN \$250,000.00 regardless of the contract amount referred to in the Articles of Agreement.
- 2.5** A security deposit referred to in CS2.2.2 and CS2.2.2.3 shall be in the form of:
- 2.5.1** a certified cheque payable to the Receiver General of Canada and drawn on a member of the Canadian Payments Association or a local cooperative credit society that is a member of a central cooperative credit society having membership in the Canadian Payments Association; or
 - 2.5.2** bonds of or unconditionally guaranteed as to principal and interest by the Government of Canada.
- 2.6** A bond referred to in CS2.5.2 shall be:
- 2.6.1** payable to bearer;
 - 2.6.2** accompanied by a duly executed instrument of transfer to the Receiver General for Canada in the form prescribed by the Domestic Bonds of Canada Regulations; or
 - 2.6.3** registered as to principal or as to principal and interest in the name of the Receiver General for Canada.

MODEL PERFORMANCE BOND

No. _____ \$

KNOW ALL PERSONS BY THESE PRESENTS, That

as Principal, hereinafter called the Principal, and

as Surety, hereinafter called the Surety, are, subject to the conditions hereinafter contained, held and firmly bound unto

as Obligee, hereinafter called the Crown, in the amount of _____ Dollars (_____ \$), lawful money of , for the payment of which sum, well and truly to be made, the Principal and the Surety bind themselves, their heirs, executors, administrators, successors and assigns, jointly and severally, or, where this bond is subject to the law of the Ontario, Canada, as solidary debtors, and firmly by these presents.

SIGNED AND SEALED this ____ day _____ of 20____

WHEREAS, the Principal has entered into a Contract with Her Majesty, dated the ____ day of _____ 20____
for _____

which Contract is by reference made a part hereof, and is hereinafter referred to as the Contract.

NOW, THEREFORE, THE CONDITIONS OF THIS OBLIGATION are such that if the Principal shall well and faithfully observe and perform all the obligations on the part of the Principal to be observed and performed in connection with the Contract, then this obligation shall be void; otherwise it shall remain in full force and effect, subject, however, to the following conditions:

1. Whenever the Principal shall be, and declared by Her Majesty to be, in default under the Contract the Surety shall:
 - 1) If the Work is not taken out of the Principal's hands, remedy the default of the Principal;
 - 2) If the Work is taken out of the Principal's hands as per GC38 & GC39 and the Crown directs the surety to undertake the completion of the Work, complete the Work in accordance with the Contract provided that if a contract is entered into for the completion of the Work:
 - i. it shall be between the Surety and the completing Contractor; and
 - ii. the selection of such completing Contractor shall be subject to the approval of Her Majesty;
 - 3) If the work is taken out of the Principal's hands as per GC38 & GC39 and Her Majesty, after reasonable notice to the Surety, does not direct the Surety to undertake the completion of the Work, assume the financial responsibility for the cost of completion in excess of the moneys available to Her Majesty under the Contract;
 - 4) Be liable for and pay all the excess costs of completion of the Contract; and
 - 5) Not be entitled to any contract moneys earned by the Principal, up to the date of its default on the Contract and any holdbacks relating to such earned contract moneys held by Her Majesty, and the liability of the Surety under this Bond shall remain unchanged provided, however, and without restricting the generality of the foregoing, upon the completion of the Contract to the satisfaction of Her Majesty, any contract moneys earned by the Principal or holdbacks related thereto held by Her Majesty may be paid to the Surety by Her Majesty.
2. The Surety shall not be liable for a greater sum than the amount specified in this Bond.

No suit or action shall be instituted by Her Majesty herein against the Surety pursuant to the Domestic Bonds of Canada Regulations.

These presents after the expiration of two (2) years from the date on which final payment under the Contract is due and payable.

IN TESTIMONY WHEREOF, the Principal has hereto set its hand and affixed its seal, and the Surety has caused these presents to be sealed with its corporate seal duly attested by the signature of its authorized signing authority, the day and year first above written.

SIGNED, SEALED AND DELIVERED
in the presence of:

Witness

Principal

Surety

Note: Affix corporate seal if applicable

MODEL LABOUR AND MATERIAL PAYMENT BOND

No. _____

KNOW ALL PERSONS BY THESE PRESENTS, That

as Principal, hereinafter called the Principal, and

as Surety, hereinafter called the Surety, are, subject to the conditions hereinafter contained, held and firmly bound unto HER MAJESTY THE QUEEN IN RIGHT OF CANADA AS REPRESENTED BY THE MINISTER OF FOREIGN AFFAIRS & INTERNATIONAL TRADE.

as Obligee, hereinafter called Her Majesty, in the amount of _____ Dollars (_____ \$), lawful money of Ontario, Canada, for the payment of which sum, well and truly to be made, the Principal and the Surety bind themselves, their heirs, executors, administrators, successors and assigns, jointly and severally, firmly by these presents.

SIGNED AND SEALED this ____ day _____ of _____ 20____.

WHEREAS, the Principal has entered into a Contract with Her Majesty, dated the ____ day of _____ 20____ for _____

which Contract is by reference made a part hereof, and is hereinafter referred to as the Contract.

NOW, THEREFORE, THE CONDITIONS OF THIS OBLIGATION are such that, if payment is promptly made to all Claimants who have performed labour and services or supplied material in connection with the Contract and any and all duly authorized modifications and extensions of the Contract that may hereafter be made, notice of which modifications and extensions to the Surety being hereby waived, then this obligation shall be void; otherwise it shall remain in full force and effect, subject, however, to the following conditions:

For the purpose of this bond, a Claimant is defined as one having a direct contract with the Principal or any Sub-Contractor of the Principal for labour, material or both, used or reasonably required for use in the performance of the Contract, labour and material being construed to include that part of water, gas, power, light, heat, oil, gasoline, telephone service or rental of equipment (but excluding rental of equipment where the rent pursuant to an agreement is to be applied towards the purchase price thereof) directly applicable to the Contract.

1. For the purpose of this bond, no payment is required to be made in respect of a claim for payment for labour or services performed or material supplied in connection with the Contract that represents a capital expenditure, overhead or general administration costs incurred by the Principal during the currency or in respect of the Contract.
2. The Principal and the Surety hereby jointly and severally agree with Her Majesty that if any Claimant has not been paid as provided for under the terms of his contract with the Principal or a Subcontractor of the Principal before the expiration of a period of ninety (90) days after the date on which the last of such Claimant's labour or service was done or performed or materials were supplied by such Claimant, Her Majesty may sue on this bond, have the right to prosecute the suit to final judgment for such sum or sums as may be due and have execution thereon; and such right of Her Majesty is assigned by virtue of Part VIII of the Financial Administration Act of Canada to such Claimant.
3. For the purpose of this bond, the liability of the Surety and the Principal to make payment to any claimant not having a contract directly with the Principal shall be limited to that amount which the

- Principal would have been obliged to pay to such claimant had the provisions of the applicable provincial or territorial legislation on lien or privileges been applicable to the Work. A claimant need not comply with provisions of such legislation setting out steps by way of notice, registration or otherwise as might have been necessary to preserve or perfect any claim for lien or privilege which the claimant might have had. Any such claimant shall be entitled to pursue a claim and to recover judgment hereunder subject to the terms and notification provisions of the Bond.
4. Any material change in the Contract between the Principal and Her Majesty shall not prejudice the rights or interest of any Claimant under this Bond who is not instrumental in bringing about or has not caused such change.
 5. No suit or action shall be commenced hereunder by any Claimant:
 - 1) Unless such Claimant shall have given written notice within the time limits hereinafter set forth to the Principal and the Surety above named, stating with substantial accuracy the amount claimed. Such notice shall be served by mailing the same by registered mail to the Principal and the Surety at any place where an office is regularly maintained for the transaction of business by such persons or served in which legal process may be served in Ontario, Canada, in which the subject matter of the contract is located. Such notice shall be given:
 - i. in respect of any claim for the amount or any portion thereof required to be held back from the Claimant by the Principal or by the Sub-Contractor of the Principal under either the terms of the Claimant's contract with the Principal or the Claimant's Contract with the Sub-Contractor of the Principal within one hundred and twenty (120) days after such Claimant should have been paid in full under his contract;
 - ii. In respect of any claim other than for the holdback or portion thereof referred to above within one hundred and twenty (120) days after the date upon which such Claimant did or performed the last of the service, work or labour or furnished the last of the materials for which such claim is made under the Claimant's Contract with the Principal or a Subcontractor of the Principal;
 - 2) After the expiration of one (1) year following the date on which the Principal ceased work on the said contract, including work performed under the guarantees provided in the Contract; and
 - 3) Other than in a court of competent jurisdiction in Ontario, Canada, in which the subject matter of the Contract or any part thereof is situated and not elsewhere, and the parties hereto hereby agree to submit to the jurisdiction of such court.
 6. The amount of this Bond shall be reduced by and to the extent of any payment or payments made in good faith hereunder.
 7. The Surety shall not be entitled to claim any moneys relating to the Contract and the liability of the Surety under this Bond shall remain unchanged and, without restricting the generality of the foregoing, the Surety shall pay all valid claims of Claimants under this Bond before any moneys relating to the Contract held by Her Majesty are paid to the Surety by Her Majesty.
 8. The Surety shall not be liable for a greater sum than the amount specified in this bond.

IN TESTIMONY WHEREOF, the Principal has hereto set its hand and affixed its seal, and the Surety has caused these presents to be sealed with its corporate seal duly attested by the signature of its authorized signing authority, the day and year first above written.

SIGNED, SEALED AND DELIVERED
in the presence of:

Witness

Principal

Surety

Note: Affix corporate seal if applicable

SECTION "VI" – LABOUR CONDITIONS**LC1 NON-DISCRIMINATION IN HIRING AND EMPLOYMENT OF LABOUR**

1.1 The Contractor agrees that:

1.1.1 in the hiring and employment of workers to perform any Work under the Contract, the Contractor will not refuse to employ and will not discriminate in any manner against any person because:

1.1.1.1 of that person's race, national origin, colour, religion, age, sex or marital status;

1.1.1.2 of the race, national origin, colour, religion, age, sex, or marital status of any person having any relationship or association with that person; or

1.1.1.3 a complaint has been made or information has been given by or in respect of that person relating to an alleged failure by the Contractor to comply with subparagraph (LC1.1.1.1.) or (LC1.1.1.2);

1.2 If any question arises as to whether the Contractor has failed to comply with the provision described in paragraph (LC1.1), the Minister or any person designated by the Minister shall decide the question and his decision shall be final for the purposes of the Contract; and

1.3 Failure to comply with the aforementioned clauses (LC1.1.1) and (LC1.1.2) regarding non-discrimination shall constitute a material breach of the Contract.

LC2 LABOUR

2.1 The Contractor further agrees to pay in employing labour, wages that are in conformity with all applicable legislation and norms in force in the place in which the Work is being performed.

Appendix A – Statement of Work

Title	2
Background.....	2
Objective	2
Project General Requirements.....	2
Scope of Work.....	3
1 Garage Works	3
2 Main Building Works.....	4
3 Exterior Works	6
Annex A – A4-63-01-01 Garage Details	7
Annex B – Garage Dimensions	7
Annex C – A4-61-01-01 – Window Diagram, Plan 01	7
Annex D – A4-61-02-01 – Window Diagram, Plan 02	7
Annex E – A4-62-01-01 – Entrance Steps and Ramp.....	7
Annex F – A4-52-00-01 – Repair Detail Front Porch.....	7
Annex G – A4-62-01-02 – Storage Shed	7
Annex H – Courtyard Improvement Area	7
Annex I – Photos of existing building conditions.....	7

SOW1. Title

Restoration of the Official Residence at the Embassy of Canada to Norway in Oslo.

SOW2. Background

The Official Residence at the Embassy of Canada to Norway, herein referred to as the “Official Residence”, dates as far back as 1923. Due to the buildings’ age and long-term exposure to weather conditions, there are several deficiencies identified as in need of improvements, such as window restoration, cladding replacement, and retrofits to improve building efficiencies.

The Official Residence and surrounding property has also undergone an assessment conducted by Oslo Municipality’s Cultural Heritage Management Office, Byantikvaren. This assessment concluded with the Official Residence and certain portions of the surrounding property being placed on Byantikvaren’s Yellow List of Heritage Sites and Buildings Worthy of Conservation, herein referred to as the “Yellow List”.

In the name of conserving the building’s unique design and character, there are certain limitations prescribed by Byantikvaren that the Department of Foreign Affairs, Trade, and Development (“DFATD”) must comply with. These limitations have the greatest impact on the garage; in order to carry out the retrofits deemed necessary by DFATD, the garage must be dismantled and reconstructed at a new location on the property. This will require a new concrete slab to be cast in preparation for the garage’s relocation.

In addition to this, windows on the garage and main building must be restored rather than replaced to the greatest extent possible.

SOW3. Objective

The objective of the works is to restore and retrofit several elements of the Official Residence, while conserving the building’s original design and character, the main focus being on the garage, main building, and auxiliary structures. Restoration of the building elements will provide embassy staff, clients, and visitors, safer and more practical working conditions, whilst respecting the building’s character.

To support the objectives of the project, DFATD requires the Contractor to undertake several key tasks, all of which are identified herein.

SOW4. Project General Requirements

Language of Work

The Contractor must have at a minimum one (1) representative able to communicate verbally and in writing in English.

All communications with Government of Canada staff, as well as any submittals, must be in English or French.

Communications

All communication must be directed through the Departmental Representative.

If the communication is technical in nature, then the communication may be directed to the Technical Authority, the Departmental Representative must be copied if communication is in Email format.

Hours of Work

The hours of work for this project are 08h00 to 17h00, local time in Oslo, Norway, Monday – Friday.

Drawings and Specifications

All required drawings and specifications attached in the Annexes have been created by Hille Melbye arkitekter AS for the purpose of this work. The documents were originally created in Norwegian and have been translated to English.

Constraints

As detailed in the background of this document, Byantikvaren has deemed the Official Residence and portions of the surrounding property on its official 'Yellow List' of cultural monuments. Byantikvaren has provided their constraints regarding the renovation of the Official Residence, to which DFATD must comply with. Any deviations required from this Statement of Work, or, details provided in the specifications, must be proposed to the Departmental Representative in writing.

The Departmental Representative will be responsible for presenting proposed alterations to the plan to Byantikvaren for approval. The Contractor must not proceed with any deviations until they have received written confirmation from the Departmental Representative that Byantikvaren is in agreement with the proposed deviations, or, the deviation provides no conflict with Byantikvaren's recommendations.

SOW5. Scope of Work

All work described herein is to be undertaken by the Contractor in accordance with drawings and specifications included in the annexes of this document. The Contractor shall carry-out to the satisfaction of the Departmental Representative the following tasks described in each section below.

All restoration work must be carried out with the upmost care for preserving original detailing and ornamental profiles of the building.

Prior to commencing the works specified below, the Contractor must attend a Site Survey with representatives from DFATD to assess the property and confirm all measurements required for the works.

The Site Survey will be organized by a representative of DFATD within one (1) week of contract award at a time mutually convenient for DFATD and the Contractor.

1 Garage Works

1.1 Dismantling

- 1.1.1 Dismantle the garage into sections in preparation for transportation to the new site.
- 1.1.2 Precautions must be taken to ensure window panes are not damaged in the dismantling process.

1.2 Relocation

Cast concrete slab for new garage at the location identified by DFATD. The location where the new concrete slab is to be cast will be identified during the Site Survey.

1.3 Retrofits

- 1.3.1 All retrofits to the garage described in the sections below must be completed in accordance with the drawings and specifications provided in Annexes A and B.
- 1.3.2 See Annex I for photos depicting the existing garage conditions.

Gate Widening

- 1.3.3 Replace centre column of driveway entrance with single beam spanning the opening.

- 1.3.4 Replace existing gate door with vertically hung bi-fold doors.
- 1.3.5 New gate doors must be designed based on drawings found in Annex A.
- 1.3.6 Install remote-activated automated gate opener.
- 1.3.7 Dimensions required for the works can be found in Annex B.

Hidden Side Door

- 1.3.8 Install new hidden side door to the garage.
- 1.3.9 Positioning and dimensions of hidden side door are described in Annex A.
- 1.3.10 Hidden side door must be produced with same exterior cladding as the garage.

Window Restoration

- 1.3.11 Garage windows are to be removed, restored, and reinstalled, following the same method identified for windows under the Main Building Works (section 2.1 – Window Restoration).

2 Main Building Works

2.1 Window Restoration

Conditions and Specifications

- 2.1.1 See Annex I for photos depicting the existing window conditions.
- 2.1.2 Windows identified as in need of refurbishment are identified in Annexes C and D.

Method

- 2.1.3 The Contractor must install new inward-opening, insulating, glass units prior to the original windows being dismantled for security reasons.
- 2.1.4 Following the install of the new insulating glass units, the Contractor must carry out the following tasks:
 - 2.1.4.1 Remove window panes from their respective structure (garage or main building);
 - 2.1.4.2 Transport glass to an off-site location for restoration;
 - 2.1.4.3 Restore glass at an off-site location with the intention of restoring the original windows to the greatest extent possible by:
 - Carefully scrape windows to remove debris; and
 - Keeping old layers of paint that do not loosen in order to avoid the risk of damaging the glass.
- 2.1.5 Any glass not cracked, or damaged, is to be kept.
- 2.1.6 Restore the window frames, following the methods below:
 - Carry out puttying and painting work based on original design; and
 - Paint window frames to match original colour.
- 2.1.7 Reinstall restored window panes and frames in their original position.

2.2 Façade Cladding Replacement

Conditions and Specifications

- 2.2.1 See Annex I for photos depicting the existing cladding conditions.
- 2.2.2 The approximate size of the area to be inspected and restored is 255m², excluding window openings.

Cladding Board Inspection

- 2.2.3 The façade cladding must be inspected by the Contractor during the Site Survey with Byantikvaren identified in section SOW 4. Project General Requirements, of this document.
- 2.2.4 During the Site Survey, the Contractor must identify to Byantikvaren which cladding boards must be replaced and which may be retained.

Cladding Board Renovations

- 2.2.5 Replace cladding boards identified as non-viable during the site survey with new cladding boards.
- 2.2.6 Replacement cladding boards must:
- Display the same physical profile (material, colour, and size) of the existing cladding; and
 - Be laid in the same pattern as the existing cladding.
- 2.2.7 The Contractor must take care to ensure existing detailing and ornamentation are preserved, or, where applicable, restored, to match the original building design.

2.3 Kitchen Deck and Hedge Construction

- 2.3.1 Construct new deck to main building's kitchen entrance, located along the main building's North-East facing façade, as described below:
- Approximate size of deck: 55m²;
 - Material to be used for deck build: traditional quarry slate; and
 - Landscaping fabric must be laid under base layer of deck to prevent weed growth between deck slates.
- 2.3.2 The Contractor will plant a hedge along boundary to adjoining property for the purpose of privacy screening between driveway and rear garden, as described below:
- Maximum height of matured hedge must not exceed 2000mm; and
 - Hedge type must be suitable for its planted location and climate.
- 3.3.3 The Contractor must obtain approval from the Departmental Representative confirming the proposed hedge type is suitable prior to planting the hedge.

2.4 Entrance Step and Ramp Installation

Conditions and Specifications

- 2.4.1 See Annex E for dimensions and specifications of entrance steps and ramp, heating cables, and railing.
- 2.4.2 See Annex I for photos depicting the existing steps and ramp.
- 2.4.3 Construct new entrance steps and ramp, attached to the main building's main entrance, located along the North-West façade, as described below.

Masonry

- 2.4.4 Cast new concrete foundation and side walls.
- 2.4.5 Face foundation, side walls, steps, ramp run, and landing, with granite of the same colour and design of existing foundation walls of main building.
- 2.4.6 Install quarry stones in front of steps.

Underground Heating

- 2.4.7 Lay heating cables under granite flagstones of steps, ramp run, and landing.

Iron Railing Installation

- 2.4.8 Install dark wrought iron railing of approximately 20m in length.
- 2.4.9 The profile of the railing is to be in the thinnest profile manufactured.

2.5 Front Veranda Floor Improvements

- 2.5.1 See Annex F for veranda floor improvement specifications.
- 2.5.2 The Contractor must replace the existing wooden veranda flooring and screed, following the details listed below:
 - Approximate area covered 20m²;
 - New screed must be laid with 50mm cavities;
 - New screed membrane must be drawn around and down past the lower edge of the screed for the purpose of creating a continuous dip edge, as identified in Annex F;
 - Replacement flooring must be constructed of new composite terrace flooring (ex- Kebony Clear, Megawood, or product equivalent in fit, form, function, and quality) and hidden fasteners; and
 - The flooring must be installed as per the manufacturer's directions.
- 2.5.3 The Contractor must fabricate and install a white wooden panel at front of veranda with the purpose of making the drip edge as discrete as possible.

3 Exterior Works

3.1 Storage Shed

- 3.1.1 Construct a new storage shed parallel to the North-East facing façade of the main building.
- 3.1.2 See Annex G for specifications of new storage shed.
- 3.1.3 Design of the new storage shed must match the cladding, doors, and ornamentation of the garage and main building.
- 3.1.4 Prefabricated roof trusses (ex- Jattak or product equivalent in fit, form, function, and quality) must be installed for the purpose of correct load bearing.

3.2 Courtyard area Improvements

Asphalt

- 3.2.1 Lay new asphalt on groundwork and in new pathways; approximate area to be covered is 335m².
- 3.2.2 New asphalt must be laid to slope outwards from the centre of the courtyard for the purpose of leading water away from the courtyard area.

Underground Heating

- 3.2.3 Install underground heating in pedestrian areas, as displayed in red shading in Annex H.
- 3.2.4 Approximate area covered is 45m²

Landscaping

- 3.2.5 Lay topsoil and turf rolls in affected green spaces; approximate area 35m²
- 3.2.6 Apply shingles to affected areas in closest proximity to the main house; approximate area 25m²

Annex A – A4-63-01-01 Garage Details

Annex B – Garage Dimensions

Annex C – A4-61-01-01 – Window Diagram, Plan 01

Annex D – A4-61-02-01 – Window Diagram, Plan 02

Annex E – A4-62-01-01 – Entrance Steps and Ramp

Annex F – A4-52-00-01 – Repair Detail Front Porch

Annex G – A4-62-01-02 – Storage Shed

Annex H – Courtyard Improvement Area

Annex I – Photos of existing building conditions

Annex A- A4-63-01-01 Garage Details

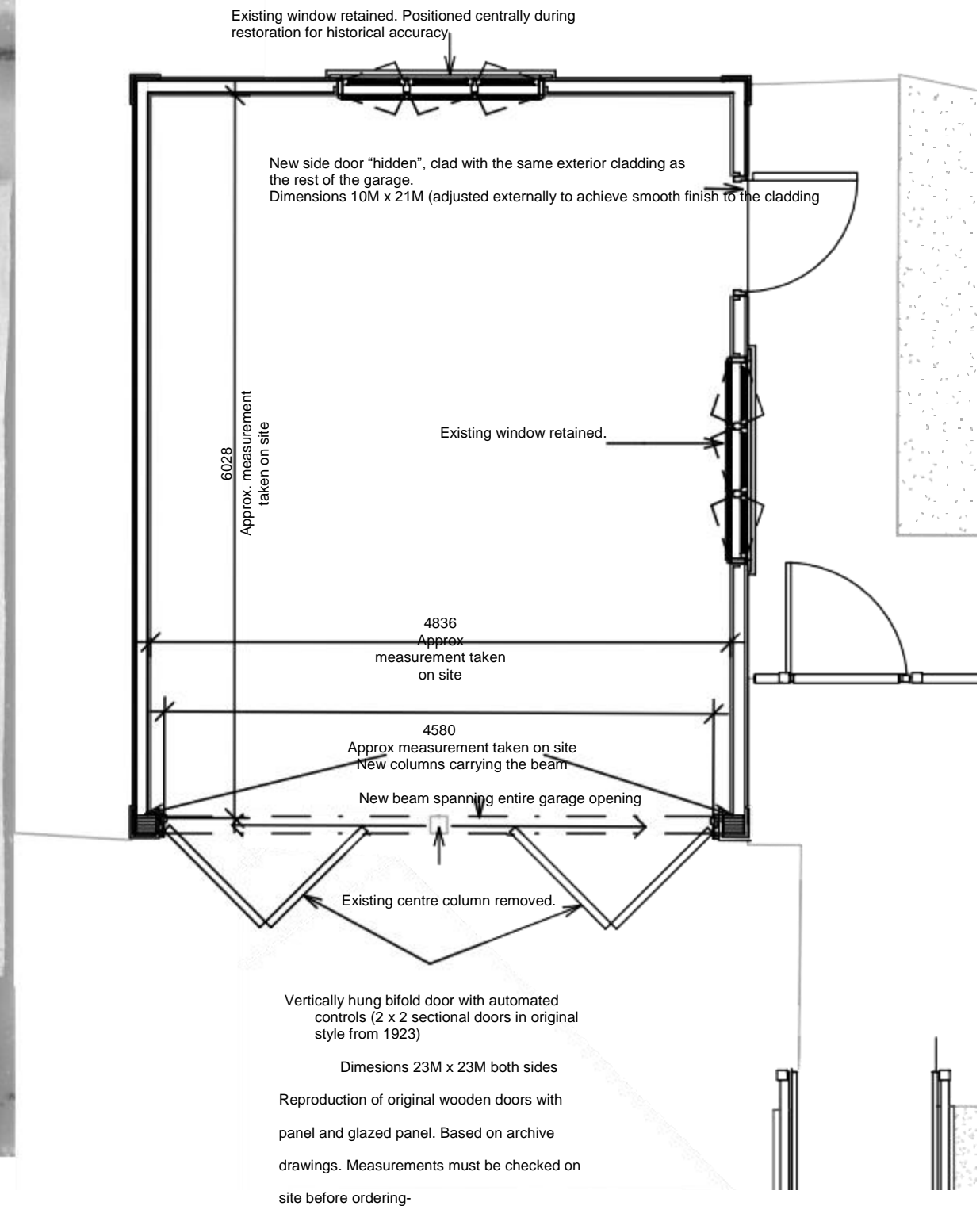
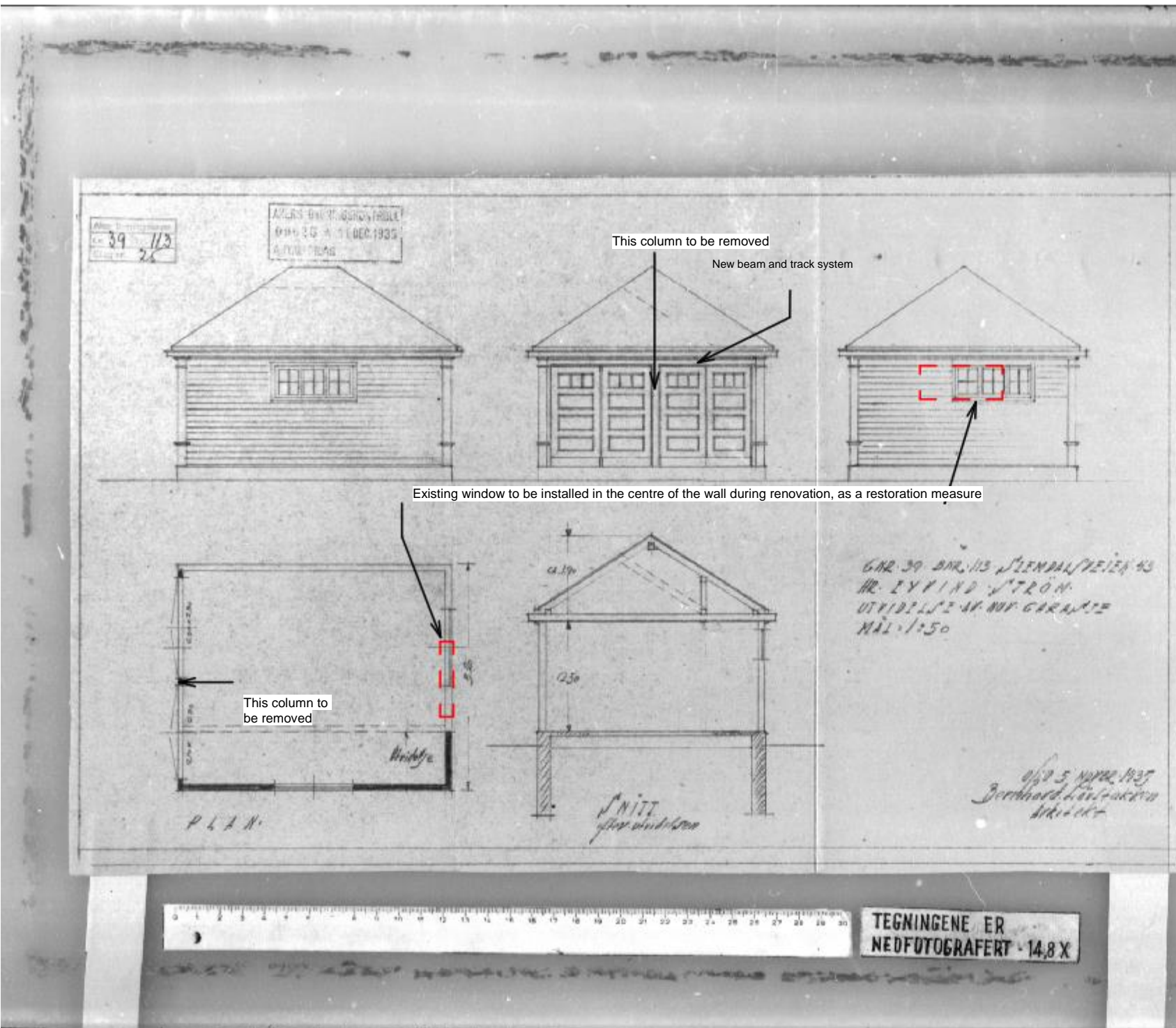

Saksnr.	Prosjekt:	Tittel:	PRO	KPR	Tegn.	Mål - A3:	Dato:	Tegn.nr.	Rev.
6625-00	Slemdalsveien 43	Garasjeskjema - ny åpning	MGA	TW	MGA		10.01.2020	A4.63.01.01	

GNR /
BNR:

G:\6625-00 Slemdalsveien 43 - Oslo\A11 Revit\Slemdalsveien 43.rvt

Annex B- Garage Works - Dimensions

EMBASSY OF CANADA TO NORWAY
Slemdalsveien 45, Oslo

MOVING AND RENOVATION OF THE GARAGE

The buildings on the plot are listed on the City of Oslo's Cultural Heritage Management Office's Yellow List of heritage sites and buildings worthy of conservation, and the garage must therefore be dismantled and re-erected on a new site, on a newly cast concrete slab. The existing windows will be restored; see restoration of windows in the façades of the main building.

Wider door opening

The column in the centre of the entrance will be removed and replaced with a beam that spans the entire opening. (140 mm x 270 mm laminated wooden beam on two 90 mm x 135 mm columns. Quality GL32). New vertically hung bifold garage doors with automated controls, produced based on archive drawings of original doors.

Dimensions:

Load distribution area, new beam.

1.4 m wide x 4.6 m long.

Dead load and snow load

Permanent load from roof structure and dead load estimated at 0.5 kN/m²

Dead load beam x partial coefficient

$$q_k = (b \times g) \times \gamma_g \Rightarrow (1.4 \times 0.5) \times 1.2 = 0.8 \text{ kN/m}$$

Snow load x partial coefficient

$$q_{k2} = (b \times Q) \times \gamma_q \Rightarrow (1.4 \times 3.0) \times 1.6 = 6.7 \text{ kN/m}$$

$$\text{Total load } q = 0.8 + 6.7 = 7.5 \text{ kN/m}$$

The moment will thus be:

$$M = \frac{q \times l^2}{8} = \frac{7.5 \times 4.6^2}{8} = 19.8 \text{ kNm}$$

Point load, suspension doors in the centre of the beam and assumed to be 1.2 kN

Moment at column will thus be:

$$M = \frac{q \times l}{2} = \frac{1.2 \times 4.6}{2} = 2.7 \text{ kNm}$$

Total moment on the beam will thus be:

$$19.8 + 2.7 = 22.5 \text{ kNm.}$$

Capacity in ultimate limit state will thus be:

$$M = \frac{q \times l^2}{8} \Rightarrow 22.5 = \frac{q \times 4.6^2}{8} \Rightarrow \frac{22.5 \times 8}{4.6^2} = q \Rightarrow q = 8.5$$

According to SINTEF Building Research Design Guide, Chapter 520.000, Table 21 c:

Laminated wooden beam 140 mm x 270 mm span width 4.5 m = 9.0 kN/m

$$\underline{8.5 < 9.0 = \text{ok}}$$

Deflection criterion:

$$\frac{l}{300} = \frac{4.6}{300} = 0.015 \text{ m} \Rightarrow 1.5 \text{ cm}$$

Columns:

Calculated based on total load 8.5 kN/m

Beam length 5 m (4.6 + eaves)

Two columns

$$\frac{q \times l}{2} = \frac{8.5 \times 5}{2} = 21.25 \text{ kN}$$

Capacity according to SINTEF Building Research Design Guide, Chapter 520.233, Table 21 b:

Column 90 mm x 135 mm, buckling length 2.7 m, has a capacity of 79.7 kN.

Columns are therefore oversized in relation to load, but will simplify fastening and installation of beam. That is why columns of this size were selected.

Annex C- A4-61-01-01 – Window Diagram, Plan 01

Window	01-01 A
Width	495
Height	1490
Glass area	0.57 m ²
Qty.	1

Window	01-01 B
Width	505
Height	1490
Glass area	0.58 m ²
Qty.	1

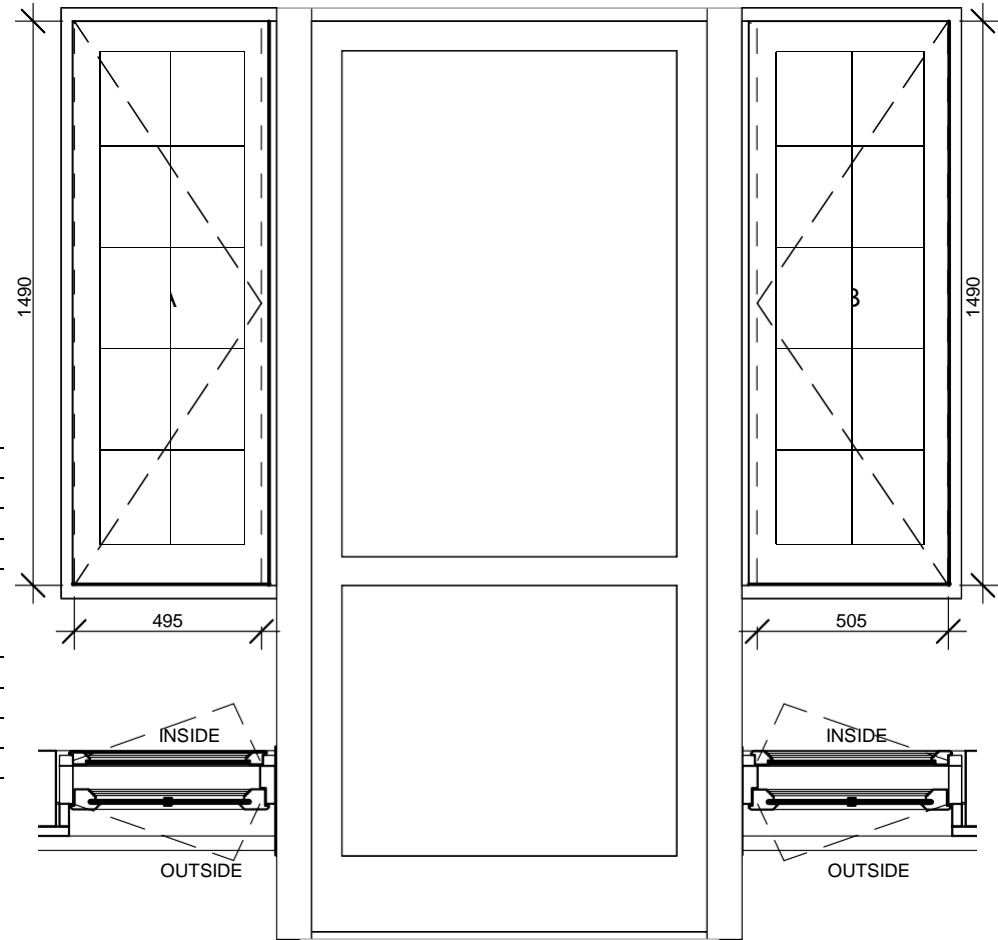

Window	01-02
Width	2310
Height	1490
Glass area	2.69 m ²
Qty.	

Inner pane screwed (not hinged)

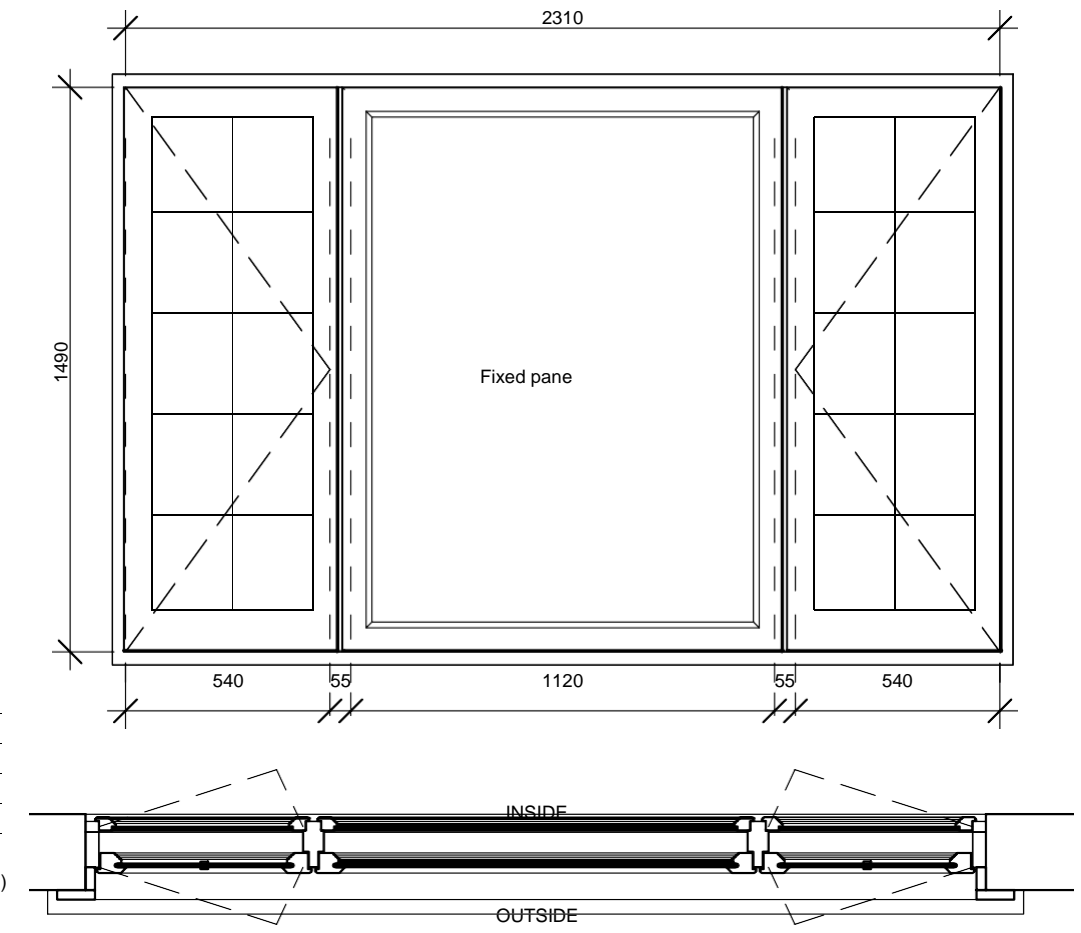

Original window taken down, restored at workshop and reinstalled exactly the same as original appearance and position. No external changes.

Inner pane replaced with insulating window due to moisture and future damage from damp caused by the current low insulating properties.

Window	01-03
Width	485
Height	1490
Glass area	2.69 m ²
Qty.	

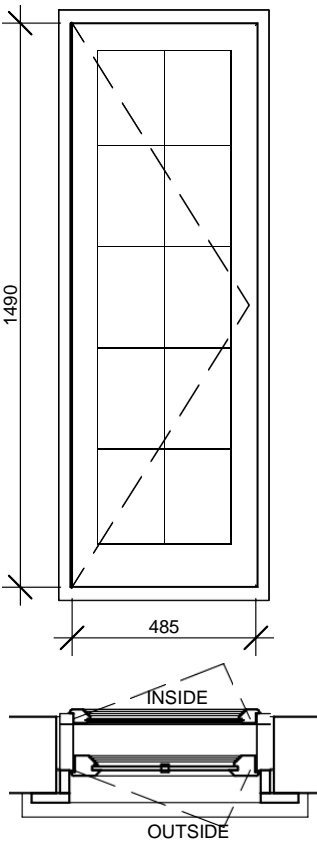

Window	01-04
Width	2294
Height	1490
Glass area	2.67 m ²
Qty.	1

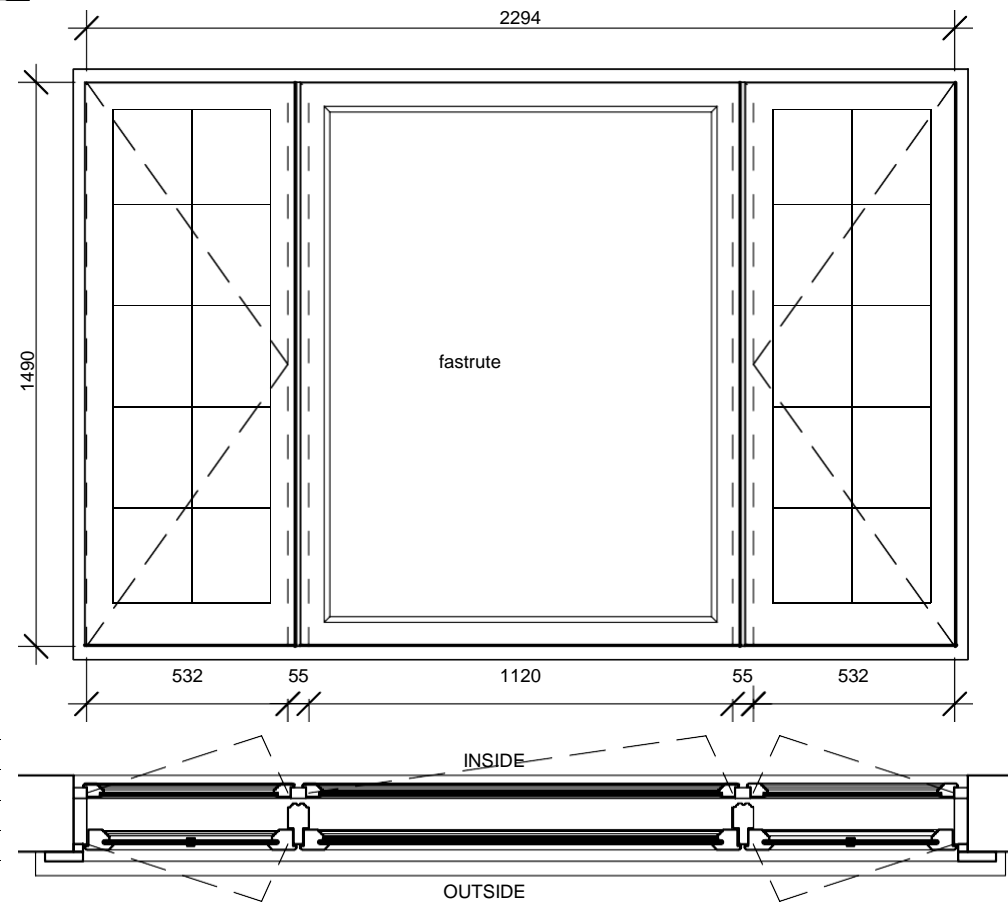

Window	01-05
Width	487
Height	1490
Glass area	2.69 m ²
Qty.	

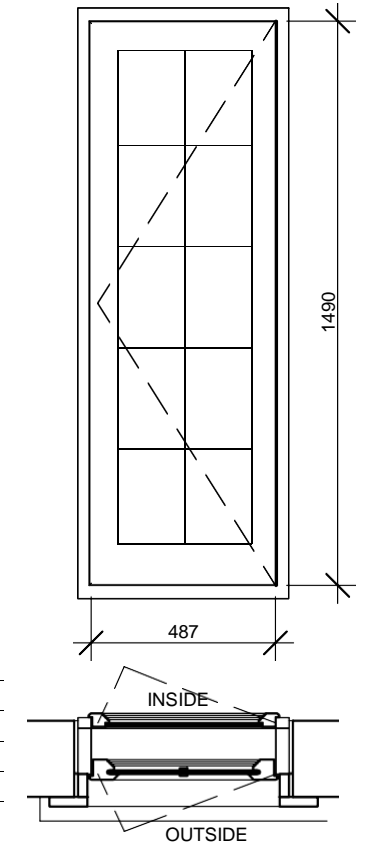

Case no. Project: Title: PRO KPR Drawing. Dim - A3: Date: Drawing no. Rev.

6625-00 Slemdalsveien 43 Window diagram Plan 01 MGA TW MGA 1:10 10.01.2020 A4.61.01.01

Approx measurements taken on site

G:\6625-00 Slemdalsveien 43 - Oslo\A11 Revit\Slemdalsveien 43.rvt

GNR /
BNR: 39/113 OSLO

Window	02-01 A
Width	485
Height	1370
Glass area	0.57 m ²
Qty.	1

Window	02-01 B
Width	485
Height	1370
Glass area	0.57 m ²
Qty.	1

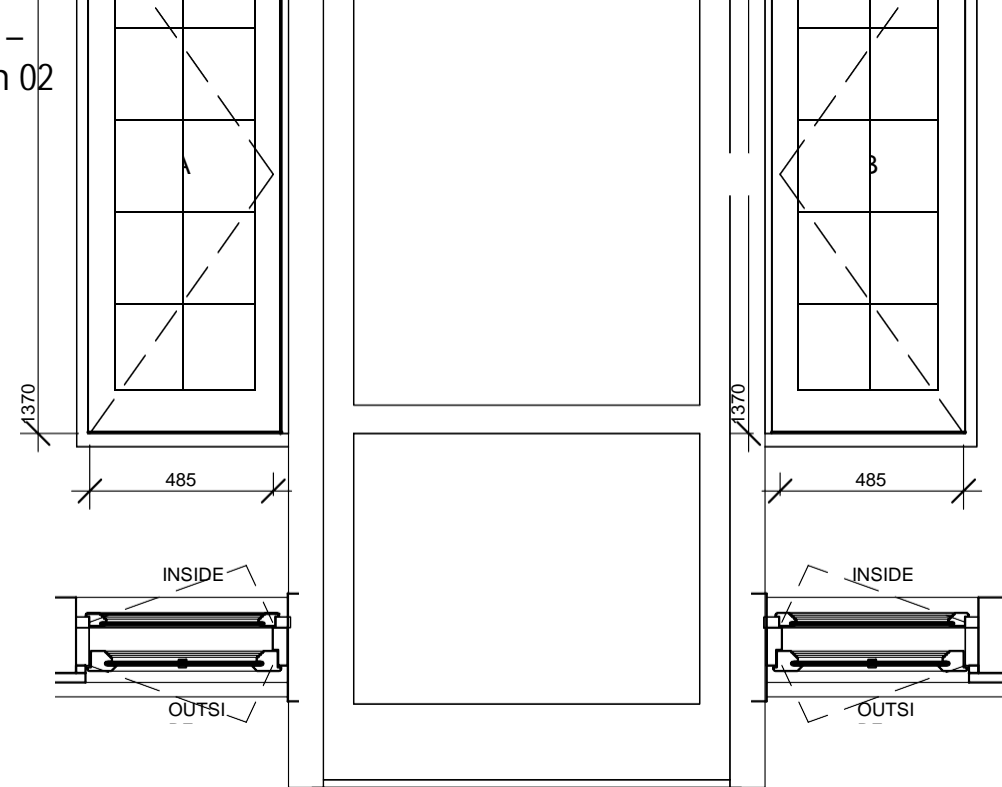

Original windows taken down, restored at workshop and reinstalled to give exactly the same appearance and position. No changes to exterior.

Inner window to be replaced with insulating window due to moisture and future damage from damp caused by current low insulating properties.

Window	02-04
Width	2295
Height	1389
Glass area	2.48 m ²
Qty.	1

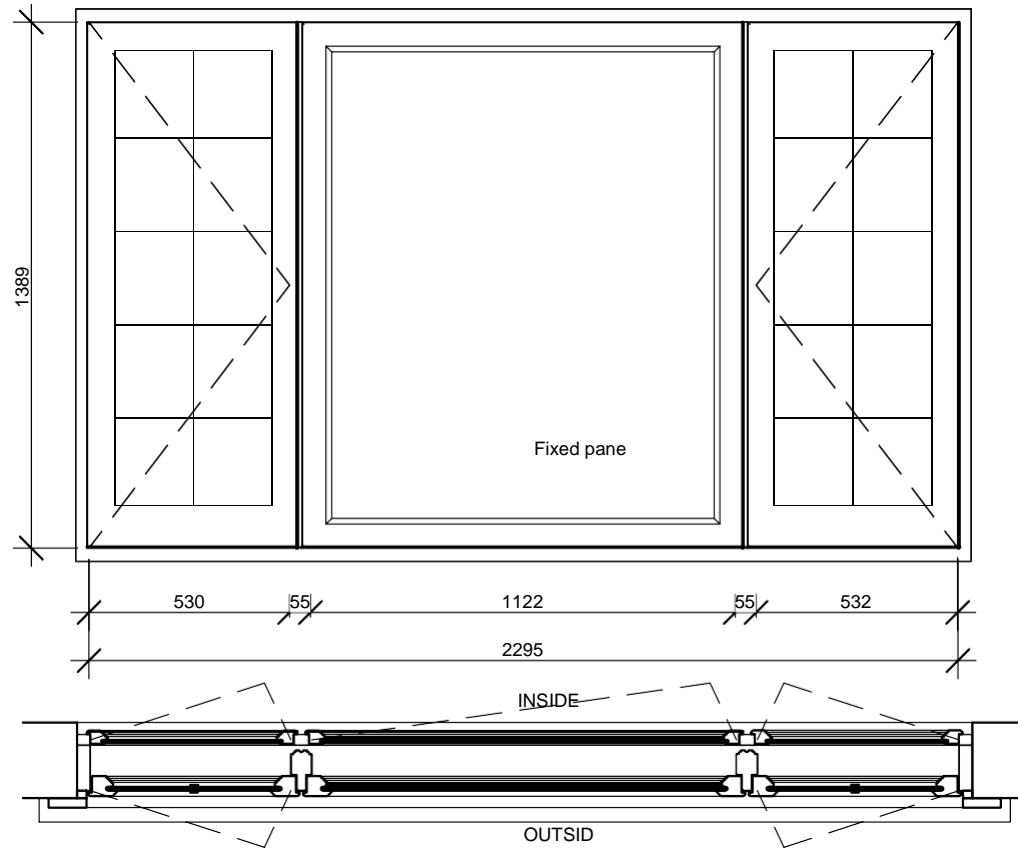

Window	02-02 A
Width	487
Height	1388
Glass area	0.58 m ²
Qty.	1

Window	02-02 B
Width	472
Height	1388
Glass area	0.56 m ²
Qty.	1

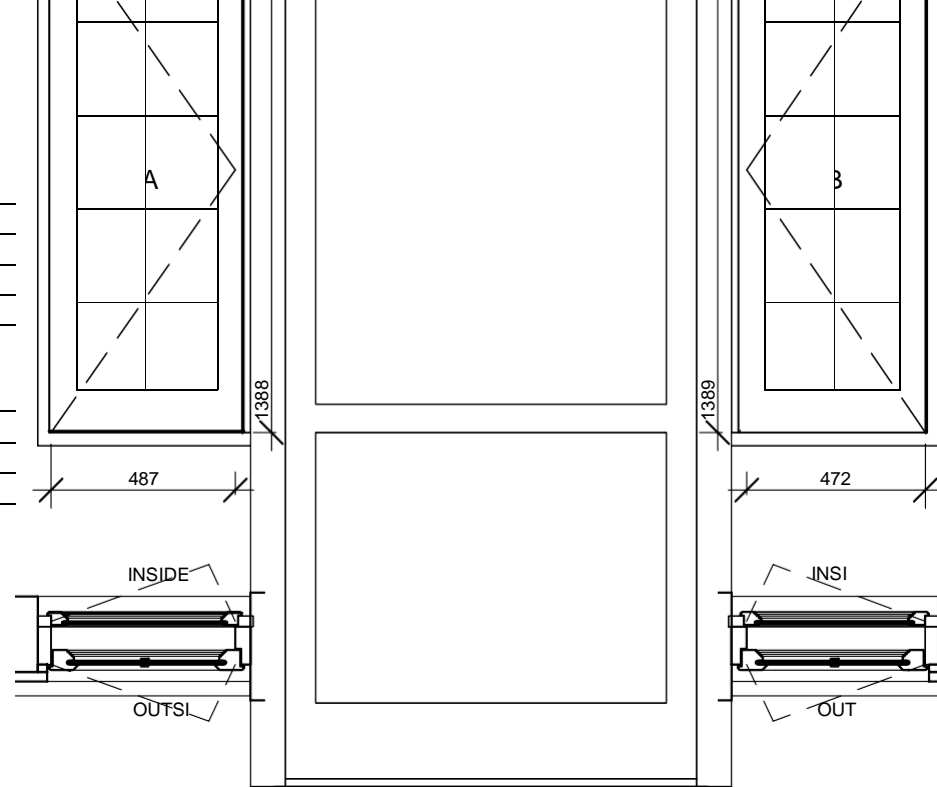

Window	02-06
Width	1136
Height	1388
Glass area	0.95 m ²
Qty.	1

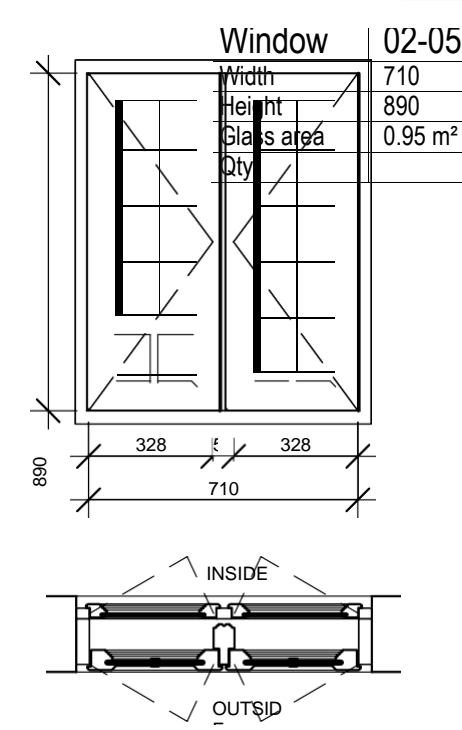
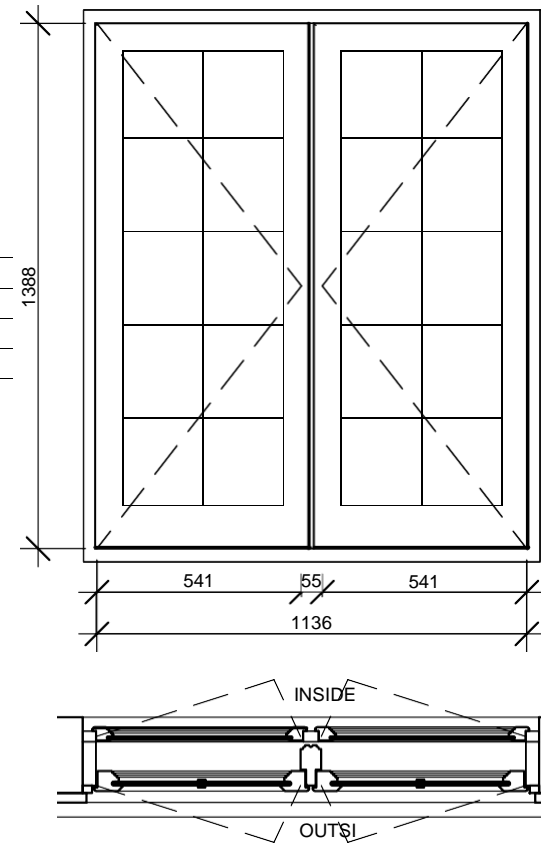

Window	02-07
Width	1640
Height	630
Glass area	0.64 m ²
Qty.	1

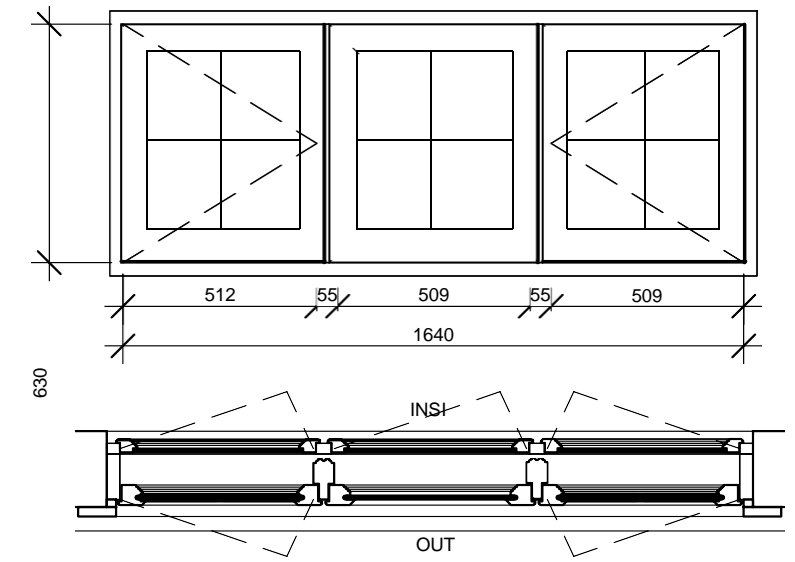

Case no. Project: Title: PRO KPR Drawing. Dim - A3: Date: Drawing no. Rev.

6625-00

Slemdalsveien 43

Window drawing Plan 02

MGA

TW

MGA

1:20

10.01.2020

A4.61.02.01

GNR / 39/113 OSLO
BNR:

APPROX
MEASUREMENTS TAKEN
ON SITE

G:\6625-00 Slemdalsveien 43 – Oslo\A11 Revit\Slemdalsveien 43.rvt



ARKITEKTER
WWW.HMARK.NO +47 23 32 72 00

Annex E – A4-62-01-01 – Entrance Steps and Ramp

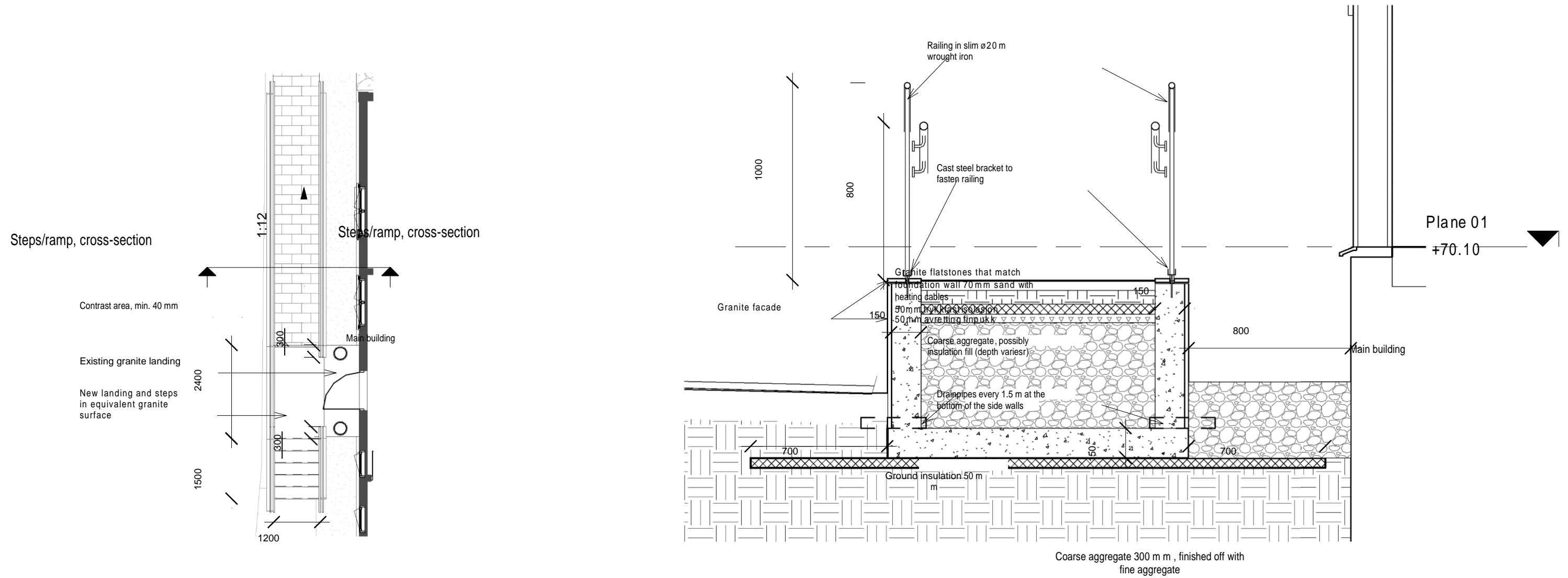

Annex F – A4-52-00-01 – Repair Detail Front Porch

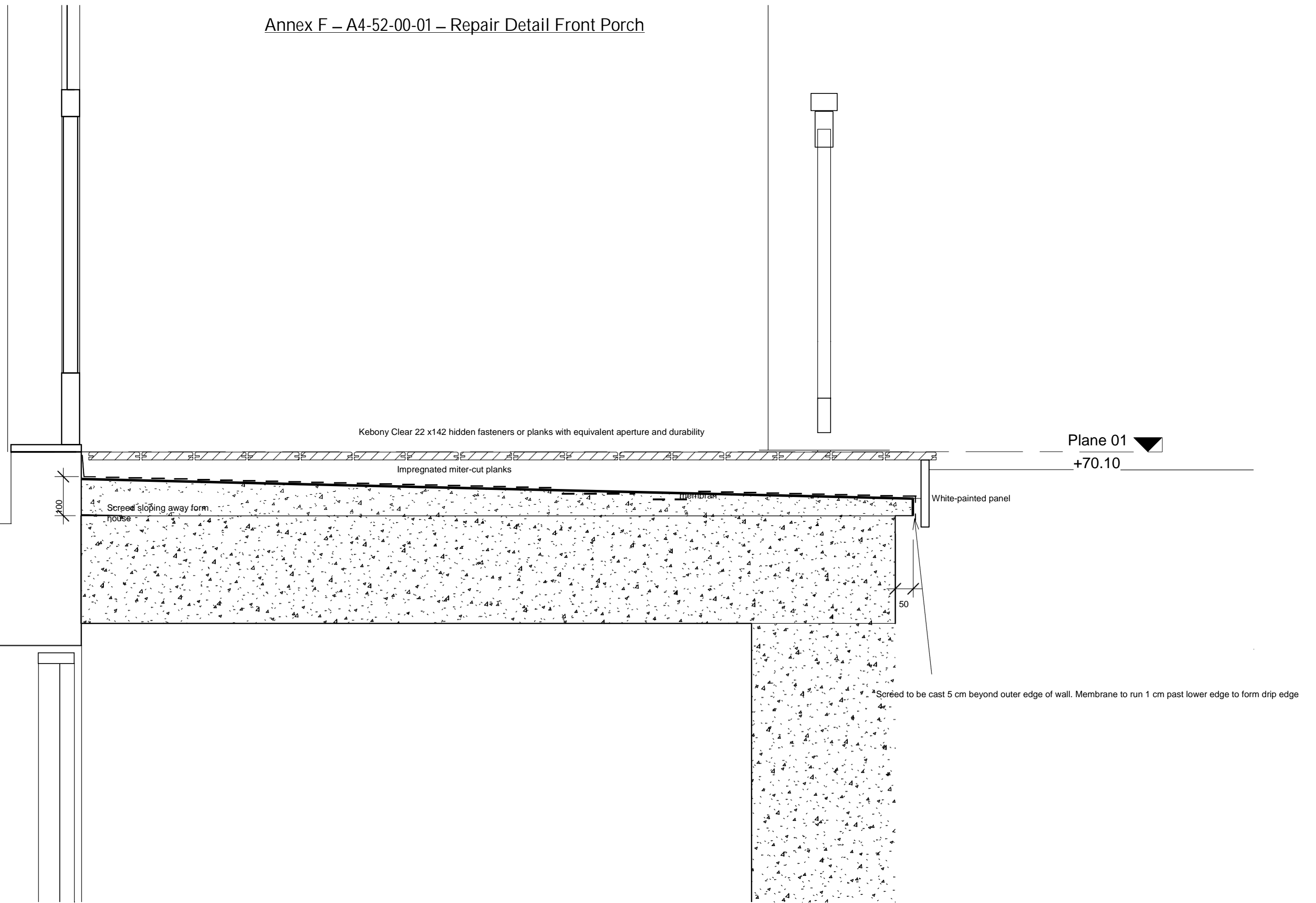

Case no.	Project	Title	PRO	KPR	Drawing	Dim - A3:	Date:	Drawing no..	Rev.
6625-00	Slemdalsveien 43	Repair detail front porch	MGA	Tore	MGA	1:10	04.11.2019	A4.52.00.01	

GNR / 39/113 OSLO

Drawing based on defect archive drawings

BNR:

Annex G – A4-62-01-02 – Storage Shed

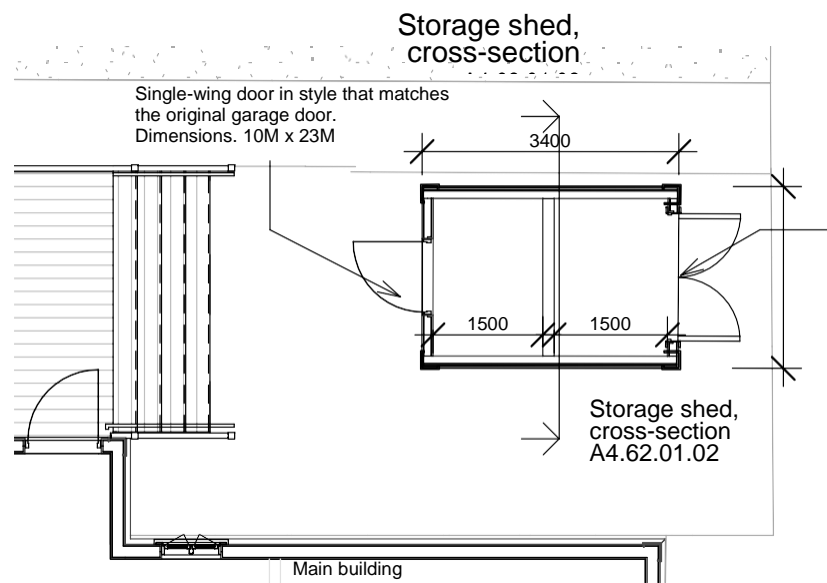

2400

Double-wing door in style matching original garage door. Dimensions 17M x 23 M

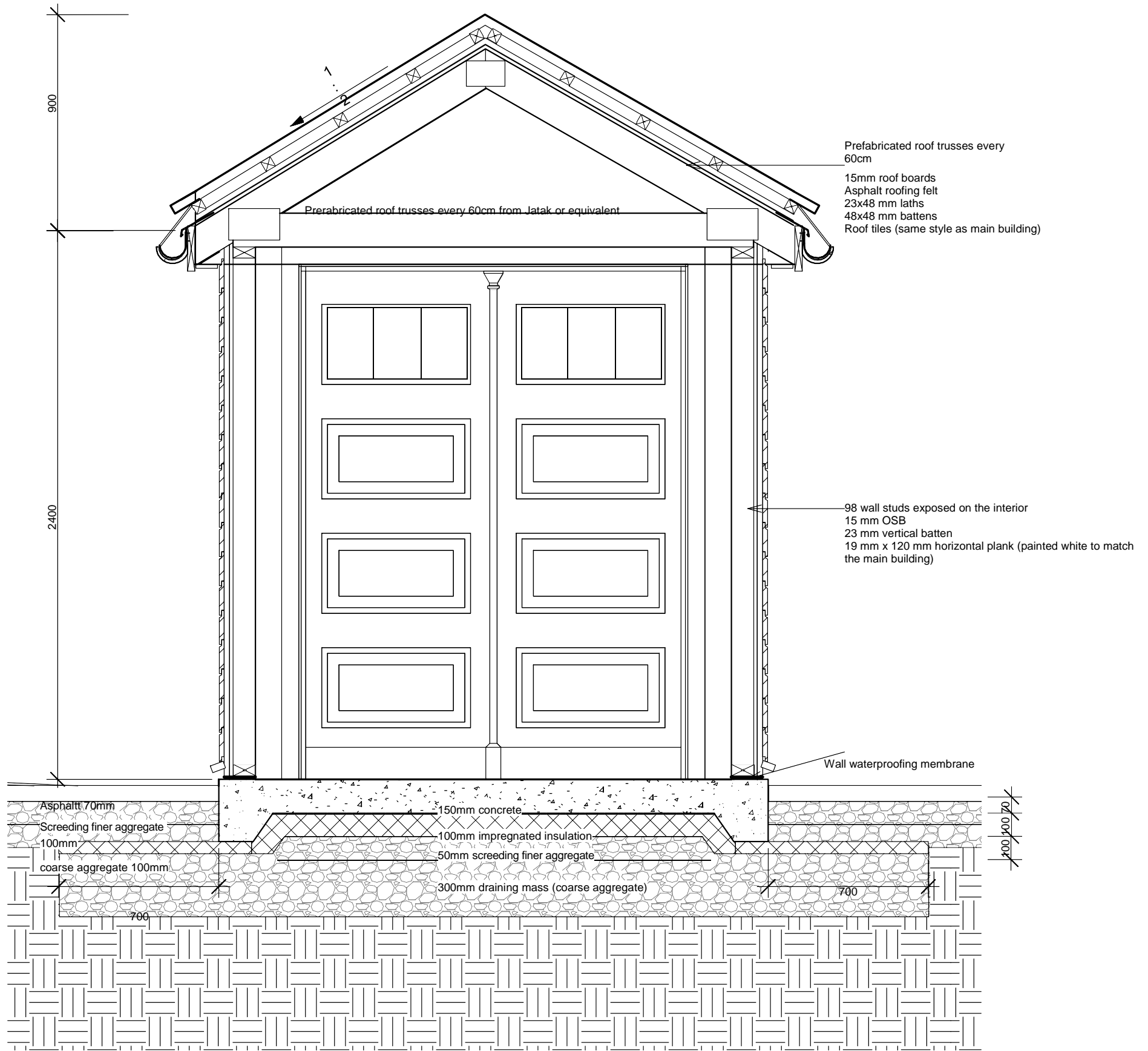

Storage shed, cross-section

1 : 20

Annex H – Court Yard Improvement Area

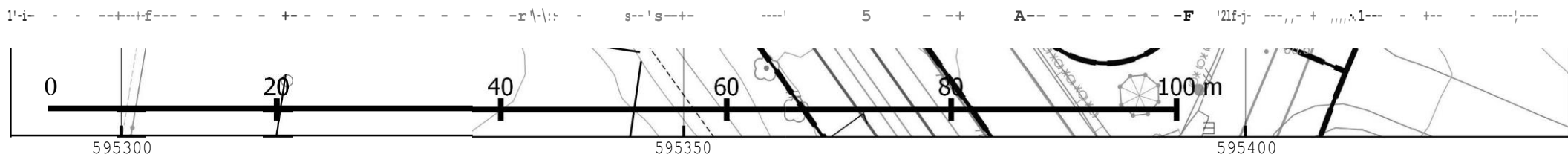

Agency for Planning & Building Services		Address: SLEMDALSVEIEN 43	
Date: 07.10.2019	Cadastral unit no./property unit no.: 39/113	Plot ID/Order no.: 119658 / 86391000	
User: svgr		Your ref.:	
Scale 1:500	This map was prepared for: Building application	Comments:	
Equidistance 1m		Applicable municipal sector plans: KDP-17	
Coordinates system: EUREF89 - UTM zone 32	Reference plane height: Zoning plan: See registered order. Background map: NN2000 Original format: A3	Biodiversity in map section. See separate map	
Original format: A3		© Agency for Planning & Building Services, City of Oslo	
		Description: NIR: 66 25 Date 08.01.2019 Revised date 20.04.2020 HILLEMELBYEARKITETERAS	

Annex I - Photos of Existing Conditions

1935 Garage Design

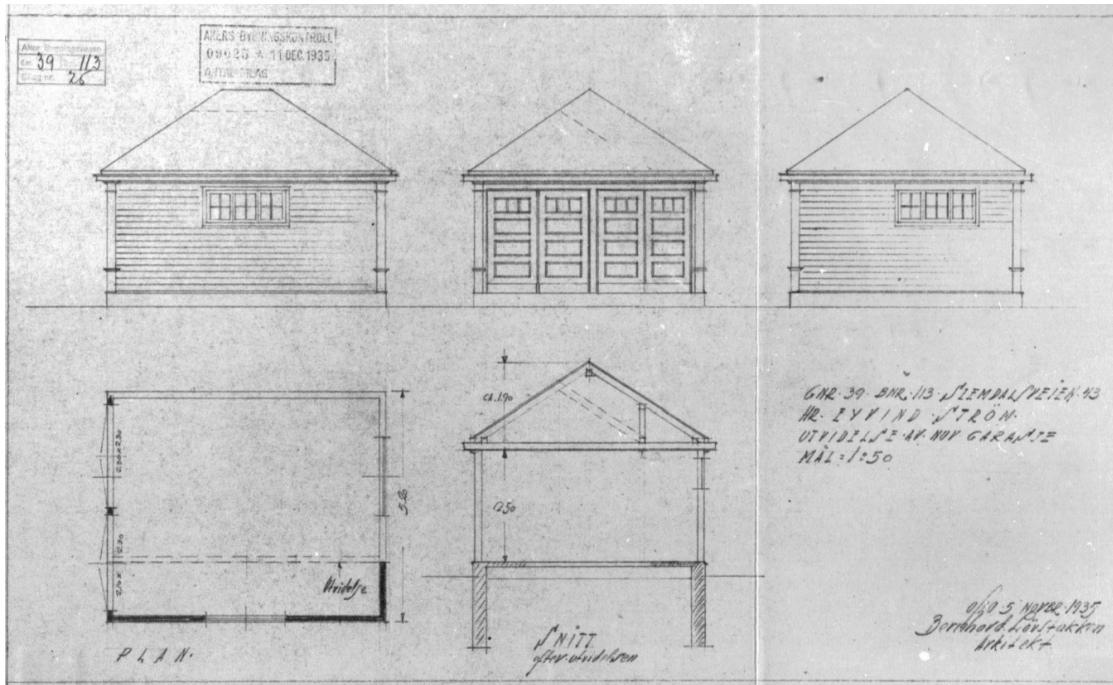

Existing Garage



Window Conditions



Kitchen Deck



Entrance Steps



Cladding



Rear and Front of Official Residence



Front Veranda



SECURITY REQUIREMENTS CHECK LIST (SRCL)
LISTE DE VÉRIFICATION DES EXIGENCES RELATIVES À LA SÉCURITÉ (LVERS)

PART A - CONTRACT INFORMATION / PARTIE A - INFORMATION CONTRACTUELLE			
1. Originating Government Department or Organization / Ministère ou organisme gouvernemental d'origine		2. Branch or Directorate / Direction générale ou Direction	
GAC		Embassy of Canada - Oslo	
3. a) Subcontract Number / Numéro du contrat de sous-traitance		3. b) Name and Address of Subcontractor / Nom et adresse du sous-traitant	
4. Brief Description of Work / Brève description du travail			
The contract consists of construction work carried out at the Official Residence in Oslo, consisting of			
<ul style="list-style-type: none"> • Taking down the existing garage and building a new one, including a new outhouse • Rehabilitating the old windows (11) • Changing of the damaged wood panels on the 4 facades 			
+			
5. a) Will the supplier require access to Controlled Goods? Le fournisseur aura-t-il accès à des marchandises contrôlées?			<input checked="" type="checkbox"/> No Non <input type="checkbox"/> Yes Oui
5. b) Will the supplier require access to unclassified military technical data subject to the provisions of the Technical Data Control Regulations? Le fournisseur aura-t-il accès à des données techniques militaires non classifiées qui sont assujetties aux dispositions du Règlement sur le contrôle des données techniques?			<input checked="" type="checkbox"/> No Non <input type="checkbox"/> Yes Oui
6. Indicate the type of access required / Indiquer le type d'accès requis			
6. a) Will the supplier and its employees require access to PROTECTED and/or CLASSIFIED information or assets? Le fournisseur ainsi que les employés auront-ils accès à des renseignements ou à des biens PROTÉGÉS et/ou CLASSIFIÉS? (Specify the level of access using the chart in Question 7. c) (Préciser le niveau d'accès en utilisant le tableau qui se trouve à la question 7. c)			<input checked="" type="checkbox"/> No Non <input type="checkbox"/> Yes Oui
6. b) Will the supplier and its employees (e.g. cleaners, maintenance personnel) require access to restricted access areas? No access to PROTECTED and/or CLASSIFIED information or assets is permitted. Le fournisseur et ses employés (p. ex. nettoyeurs, personnel d'entretien) auront-ils accès à des zones d'accès restreintes? L'accès à des renseignements ou à des biens PROTÉGÉS et/ou CLASSIFIÉS n'est pas autorisé.			<input type="checkbox"/> No Non <input checked="" type="checkbox"/> Yes Oui
6. c) Is this a commercial courier or delivery requirement with no overnight storage? S'agit-il d'un contrat de messagerie ou de livraison commerciale sans entreposage de nuit?			<input checked="" type="checkbox"/> No Non <input type="checkbox"/> Yes Oui
7. a) Indicate the type of information that the supplier will be required to access / Indiquer le type d'information auquel le fournisseur devra avoir accès			
Canada <input type="checkbox"/>	NATO / OTAN <input type="checkbox"/>		Foreign / Étranger <input type="checkbox"/>
7. b) Release restrictions / Restrictions relatives à la diffusion			
No release restrictions Aucune restriction relative à la diffusion <input type="checkbox"/>	All NATO countries Tous les pays de l'OTAN <input type="checkbox"/>		No release restrictions Aucune restriction relative à la diffusion <input type="checkbox"/>
Not releasable À ne pas diffuser <input type="checkbox"/>			
Restricted to: / Limité à: <input type="checkbox"/>	Restricted to: / Limité à: <input type="checkbox"/>		Restricted to: / Limité à: <input type="checkbox"/>
Specify country(ies): / Préciser le(s) pays:	Specify country(ies): / Préciser le(s) pays:		Specify country(ies): / Préciser le(s) pays:
7. c) Level of information / Niveau d'information			
PROTECTED A PROTÉGÉ A <input type="checkbox"/>	NATO UNCLASSIFIED NATO NON CLASSIFIÉ <input type="checkbox"/>		PROTECTED A PROTÉGÉ A <input type="checkbox"/>
PROTECTED B PROTÉGÉ B <input type="checkbox"/>	NATO RESTRICTED NATO DIFFUSION RESTREINTE <input type="checkbox"/>		PROTECTED B PROTÉGÉ B <input type="checkbox"/>
PROTECTED C PROTÉGÉ C <input type="checkbox"/>	NATO CONFIDENTIAL NATO CONFIDENTIEL <input type="checkbox"/>		PROTECTED C PROTÉGÉ C <input type="checkbox"/>
CONFIDENTIAL CONFIDENTIEL <input type="checkbox"/>	NATO SECRET NATO SECRET <input type="checkbox"/>		CONFIDENTIAL CONFIDENTIEL <input type="checkbox"/>
SECRET SECRET <input type="checkbox"/>	COSMIC TOP SECRET COSMIC TRÈS SECRET <input type="checkbox"/>		SECRET SECRET <input type="checkbox"/>
TOP SECRET TRÈS SECRET <input type="checkbox"/>			TOP SECRET TRÈS SECRET <input type="checkbox"/>
TOP SECRET (SIGINT) TRÈS SECRET (SIGINT) <input type="checkbox"/>			TOP SECRET (SIGINT) TRÈS SECRET (SIGINT) <input type="checkbox"/>

**PART A (continued) / PARTIE A (suite)**

8. Will the supplier require access to PROTECTED and/or CLASSIFIED COMSEC information or assets?
Le fournisseur aura-t-il accès à des renseignements ou à des biens COMSEC désignés PROTÉGÉS et/ou CLASSIFIÉS? No / Non Yes / Oui
If Yes, indicate the level of sensitivity:
Dans l'affirmative, indiquer le niveau de sensibilité :
9. Will the supplier require access to extremely sensitive INFOSEC information or assets?
Le fournisseur aura-t-il accès à des renseignements ou à des biens INFOSEC de nature extrêmement délicate? No / Non Yes / Oui
- Short Title(s) of material / Titre(s) abrégé(s) du matériel :
Document Number / Numéro du document :

PART B - PERSONNEL (SUPPLIER) / PARTIE B - PERSONNEL (FOURNISSEUR)

10. a) Personnel security screening level required / Niveau de contrôle de la sécurité du personnel requis
- | | | | |
|---|---|---|--|
| <input checked="" type="checkbox"/> RELIABILITY STATUS
COTE DE FIABILITÉ | <input type="checkbox"/> CONFIDENTIAL
CONFIDENTIEL | <input type="checkbox"/> SECRET
SECRET | <input type="checkbox"/> TOP SECRET
TRÈS SECRET |
| <input type="checkbox"/> TOP SECRET-SIGINT
TRÈS SECRET - SIGINT | <input type="checkbox"/> NATO CONFIDENTIAL
NATO CONFIDENTIEL | <input type="checkbox"/> NATO SECRET
NATO SECRET | <input type="checkbox"/> COSMIC TOP SECRET
COSMIC TRÈS SECRET |
| <input type="checkbox"/> SITE ACCESS
ACCÈS AUX EMPLACEMENTS | | | |
- Special comments:
Commentaires spéciaux : _____
- NOTE: If multiple levels of screening are identified, a Security Classification Guide must be provided.
REMARQUE : Si plusieurs niveaux de contrôle de sécurité sont requis, un guide de classification de la sécurité doit être fourni.
10. b) May unscreened personnel be used for portions of the work?
Du personnel sans autorisation sécuritaire peut-il se voir confier des parties du travail? No / Non Yes / Oui
If Yes, will unscreened personnel be escorted?
Dans l'affirmative, le personnel en question sera-t-il escorté? No / Non Yes / Oui

PART C - SAFEGUARDS (SUPPLIER) / PARTIE C - MESURES DE PROTECTION (FOURNISSEUR)**INFORMATION / ASSETS / RENSEIGNEMENTS / BIENS**

11. a) Will the supplier be required to receive and store PROTECTED and/or CLASSIFIED information or assets on its site or premises?
Le fournisseur sera-t-il tenu de recevoir et d'entreposer sur place des renseignements ou des biens PROTÉGÉS et/ou CLASSIFIÉS? No / Non Yes / Oui
11. b) Will the supplier be required to safeguard COMSEC information or assets?
Le fournisseur sera-t-il tenu de protéger des renseignements ou des biens COMSEC? No / Non Yes / Oui

PRODUCTION

11. c) Will the production (manufacture, and/or repair and/or modification) of PROTECTED and/or CLASSIFIED material or equipment occur at the supplier's site or premises?
Les installations du fournisseur serviront-elles à la production (fabrication et/ou réparation et/ou modification) de matériel PROTÉGÉ et/ou CLASSIFIÉ? No / Non Yes / Oui

INFORMATION TECHNOLOGY (IT) MEDIA / SUPPORT RELATIF À LA TECHNOLOGIE DE L'INFORMATION (TI)

11. d) Will the supplier be required to use its IT systems to electronically process, produce or store PROTECTED and/or CLASSIFIED information or data?
Le fournisseur sera-t-il tenu d'utiliser ses propres systèmes informatiques pour traiter, produire ou stocker électroniquement des renseignements ou des données PROTÉGÉS et/ou CLASSIFIÉS? No / Non Yes / Oui
11. e) Will there be an electronic link between the supplier's IT systems and the government department or agency?
Disposera-t-on d'un lien électronique entre le système informatique du fournisseur et celui du ministère ou de l'agence gouvernementale? No / Non Yes / Oui

**PART C - (continued) / PARTIE C - (suite)**

For users completing the form **manually** use the summary chart below to indicate the category(ies) and level(s) of safeguarding required at the supplier's site(s) or premises.

Les utilisateurs qui remplissent le formulaire **manuellement** doivent utiliser le tableau récapitulatif ci-dessous pour indiquer, pour chaque catégorie, les niveaux de sauvegarde requis aux installations du fournisseur.

For users completing the form **online** (via the Internet), the summary chart is automatically populated by your responses to previous questions.

Dans le cas des utilisateurs qui remplissent le formulaire **en ligne** (par Internet), les réponses aux questions précédentes sont automatiquement saisies dans le tableau récapitulatif.

SUMMARY CHART / TABLEAU RÉCAPITULATIF

Category Catégorie	PROTECTED PROTÉGÉ			CLASSIFIED CLASSIFIÉ			NATO				COMSEC					
	A	B	C	CONFIDENTIAL CONFIDENTIEL	SECRET	TOP SECRET TRÈS SECRET	NATO RESTRICTED NATO DIFFUSION RESTREINTE	NATO CONFIDENTIAL NATO CONFIDENTIEL	NATO SECRET	COSMIC TOP SECRET COSMIC TRÈS SECRET	PROTECTED PROTÉGÉ			CONFIDENTIAL	SECRET	TOP SECRET TRÈS SECRET
											A	B	C			
Information / Assets Renseignements / Biens Production																
IT Media / Support TI																
IT Link / Lien électronique																

12. a) Is the description of the work contained within this SRCL PROTECTED and/or CLASSIFIED?

La description du travail visé par la présente LVERS est-elle de nature PROTÉGÉE et/ou CLASSIFIÉE?

No
Non

Yes
Oui

If Yes, classify this form by annotating the top and bottom in the area entitled "Security Classification".

Dans l'affirmative, classifiez le présent formulaire en indiquant le niveau de sécurité dans la case intitulée « Classification de sécurité » au haut et au bas du formulaire.

12. b) Will the documentation attached to this SRCL be PROTECTED and/or CLASSIFIED?

La documentation associée à la présente LVERS sera-t-elle PROTÉGÉE et/ou CLASSIFIÉE?

No
Non

Yes
Oui

If Yes, classify this form by annotating the top and bottom in the area entitled "Security Classification" and indicate with attachments (e.g. SECRET with Attachments).

Dans l'affirmative, classifiez le présent formulaire en indiquant le niveau de sécurité dans la case intitulée « Classification de sécurité » au haut et au bas du formulaire et indiquez qu'il y a des pièces jointes (p. ex. SECRET avec des pièces jointes).



Contract Number / Numéro du contrat 21-183221
Security Classification / Classification de sécurité UNCLASSIFIED

PART D - AUTHORIZATION / PARTIE D - AUTORISATION

13. Organization Project Authority / Chargé de projet de l'organisme

Name (print) - Nom (en lettres moulées) Mihaela Marin	Title - Titre Common Services Officer	Signature
Telephone No. - N° de téléphone 22995352	Facsimile No. - N° de télécopieur	E-mail address - Adresse courriel mihaela.marin@international.gc.ca
		Date 28 Sept. 2020

14. Organization Security Authority / Responsable de la sécurité de l'organisme

Name (print) - Nom (en lettres moulées) Barbara Mendel	Title - Titre Mission Security Officer	Signature
Telephone No. - N° de téléphone 22995312	Facsimile No. - N° de télécopieur	E-mail address - Adresse courriel barbara.mendel@international.gc.ca
		Date 28 Sept. 2020

15. Are there additional instructions (e.g. Security Guide, Security Classification Guide) attached?
 Des instructions supplémentaires (p. ex. Guide de sécurité, Guide de classification de la sécurité) sont-elles jointes?

No / Non Yes / Oui

16. Procurement Officer / Agent d'approvisionnement

Name (print) - Nom (en lettres moulées) Meghan Andrews	Title - Titre Contract Advisor	Signature
Telephone No. - N° de téléphone	Facsimile No. - N° de télécopieur	E-mail address - Adresse courriel
		Date

17. Contracting Security Authority / Autorité contractante en matière de sécurité

Name (print) - Nom (en lettres moulées) Jacques Saumur	Title - Titre Quality Assurance Officer	Signature Saumur, Jacques 0
Telephone No. - N° de téléphone	Facsimile No. - N° de télécopieur	E-mail address - Adresse courriel jacques.saumur@tpsgc-pwgsc.gc.ca
		Date

Digitally signed by Saumur, Jacques 0
Date: 2019.10.30 08:11:47 -04'00'