



# LaSalle Causeway Bascule Bridge Main Trunnion Rehabilitation Study - Design Concept Report



Project Number: R. 099350.002



# **Lasalle Causeway Bascule Bridge Main Trunnion Rehabilitation Study – Design Concept Report**

# TABLE OF CONTENTS

<b>EXECUTIVE SUMMARY .....</b>	<b>EX-I</b>
<b>1 INTRODUCTION .....</b>	<b>1</b>
<b>2 STRUCTURE DESCRIPTION.....</b>	<b>1</b>
<b>3 PROPOSED SCOPE OF WORK .....</b>	<b>3</b>
3.1 General .....	3
3.2 Connecting Members of the Main Trunnion Assemblies .....	3
3.3 Gusset Plates and Fasteners .....	5
3.4 Pins of the Main Trunnions.....	7
<b>4 DESIGN CRITERIA.....</b>	<b>7</b>
<b>5 REHABILITATION CONCEPTS AND CONSTRUCTION STAGING.....</b>	<b>9</b>
5.1 General .....	9
5.1.1 Structural steel coating system .....	9
5.1.2 Temporary Removals.....	10
5.1.3 Implications on the bridge balance .....	11
5.2 Connecting Members of the Main Trunnion Assemblies .....	11
5.2.1 General.....	11
5.2.2 Diagonals 13-16 .....	12
5.2.3 Bottom Chords 14-16.....	15
5.2.4 Struts 14-15.....	16
5.2.5 Fixed Diagonals 15-17 .....	18
5.3 Gusset Plates and Fasteners .....	18
5.3.1 Strengthening in overstressed areas not caused by corrosion.....	19
5.3.2 Strengthening in overstressed areas caused by corrosion .....	20
5.3.3 Other strengthening due to corrosion .....	23
5.4 Summary of the proposed strengthening.....	26
<b>6 CONSTRUCTION CONSTRAINTS, STAGING AND TRAFFIC MANAGEMENT, STAGING AREAS AND SCHEDULE ...</b>	<b>26</b>
6.1 Construction Timing and Operational Constraints .....	26
6.2 Construction Staging and Traffic Management.....	27
6.3 Construction Staging Areas and Access .....	28

6.4 Construction Schedule.....	28
7 CONSTRUCTION COST ESTIMATE.....	29
8 CLOSURE .....	30
REFERENCES .....	31
APPENDIX A – WISS, JANNEY, ELSTNER ASSOCIATES’ RECOMMENDATIONS .....	32
APPENDIX B – LOCATION OF THE PROPOSED STRENGTHENING FOR THE CONNECTING MEMBERS OF THE MAIN TRUNNION ASSEMBLIES.....	37
APPENDIX C – LOCATION OF THE PROPOSED STRENGTHENING FOR THE GUSSET PLATES OF THE MAIN TRUNNION ASSEMBLIES.....	39
APPENDIX D – CONSTRUCTION SCHEDULE .....	41



---

**LIST OF FIGURES**

Figure 1 – South elevation..... 2

Figure 2 – Dimensions and Truss Member Designation..... 2

Figure 3 - Main Trunnion Assembly (a) Left: Moveable part (b) Right: Fixed part..... 3

Figure 4 – Excerpt from Table 7 of the Structural Evaluation Report (2020) showing D/C ratios for all connecting members .... 4

Figure 5 - Gusset plate expected yielding and fasteners with insufficient resistance at undeteriorated state for ULS B1 to B3 (a) Left: with loads taken according to S6-14 (b) Right: with restrictions during bridge operation..... 5

Figure 6 - Gusset plate expected yielding for ULS B1 to B3 according to S6-14 considering deterioration (a) South exterior plate (b) South interior plate (c) North exterior plate (d) North interior plate..... 6

Figure 7 – Temporary removal on the inner side of the main trunnions..... 10

Figure 8 - Temporary removal of the sidewalk (photo from 2010 rehabilitation)..... 11

Figure 9 – Existing (left) and reinforced (right) sections of 13-16 members..... 12

Figure 10 – Reinforcing side plate at node 16..... 13

Figure 11 – Intermediate bracing of two existing channels if work is performed with vehicular traffic over the bridge..... 14

Figure 12 – Wide lacing alternative..... 15

Figure 13 – Current (left) and reinforced (right) sections of 14-16 members..... 16

Figure 14 – Position of permanent diaphragms and side plates close to node 14 ..... 16

Figure 15 – Current (left) and reinforced (right) sections of 14-15 members..... 17

Figure 16 – Position of angles at the connections with nodes 14 and 15 ..... 17

Figure 17 – Current (left) and reinforced (right) sections of 15-17 members..... 18

Figure 18 – Gusset Plate Strengthening Type A1 (a) Left: View from inside the trunnion (b) Right: View from outside. .... 19

Figure 19 –Gusset Plate Strengthening Type A2 Alternative (a) Left: Plate extending to the edge angle (b) Right: Plate serving as a shim placed first ..... 20

Figure 20 – Gusset Plate Strengthening Type B ..... 21

Figure 21 - Gusset Plate Strengthening Type C (a) Left: View from inside the trunnion (b) Right: View from outside ..... 22

Figure 22 - Gusset Plate Strengthening Type D (a) Left: View from inside the trunnion (b) Right: View from outside ..... 23

Figure 23 – Significant corrosion on the bottom chord connection of the south side of the north interior plate ..... 24

Figure 24 - Gusset Plate Strengthening Type F ..... 25

Figure 25 - Interior plate of the south trunnion located in the splash zone (a) Left: Bridge opened to traffic (b) Right: Bridge during operation ..... 26

---

**LIST OF TABLES**

Table 1 - Design Criteria for the Rehabilitation of the Main Trunnion Assemblies..... 7

Table 2 - Class ‘C’ Construction Cost Estimate ..... 29

## Executive Summary

In September 2019, Public Services and Procurement Canada (PSPC) retained Parsons to provide professional engineering services related to the rehabilitation of the main trunnion bearings of the LaSalle Causeway Bascule Bridge. The scope of work for the current mandate includes: a detailed close-up inspection (including ultrasonic thickness testing) of the main trunnion assemblies and six adjacent steel members and connections; measuring the dynamic amplification of the bridge during opening and closing of the bridge using strain gauges; a structural evaluation of the main trunnion assemblies and adjacent steel members and connections in accordance with the Canadian Highway Bridge Design Code CAN/CSA S6-14 (CHBDC); development of repair and/or replacement concepts, steel coating requirements, construction staging strategies, including Class 'C' cost and working day estimates; and a traffic impact analysis.

This report presents the repair concepts for the bridge components that were found to be overstressed or deficient in the 2020 Detailed Inspection Memorandum and the 2020 Structural Evaluation Report. Out of the six connecting members that were evaluated, the findings of these studies recommended the strengthening of four (4) truss members. Moreover, all the main trunnion gusset plates were found to be locally overstressed and have some section losses. In order to keep the bridge in service for 30 years, strengthening is recommended at some locations of the main trunnion plates. The condition of the pins is determined acceptable for the targeted remaining service life of the bridge; thus, no retrofitting is required.

Design criteria are proposed for the rehabilitation work and include a deviation from the Canadian Highway Bridge Design Code, CSA-S6-19 (CHBDC) such as a maximum permissible wind speed of 69 km/h for the bridge operation. These design criteria will need to be confirmed in the detailed design stage, and the installation of wind speed monitoring equipment is strongly recommended as the 2017 Bridge motor and drive rehabilitation design was also based on operational wind speed restriction of 69 km/h. Moreover, the involvement of a wind specialist is recommended at the detailed design phase to ensure a rigorous approach in order to determine the exact pressures on the structure.

As the general condition of the members and the gusset plates is still reasonably fair, the proposed strengthening consists of adding new material to the existing steel elements. At this stage, a probable Class 'C' construction cost is estimated at \$2.6M. It is intended that the rehabilitation work will take place during the off-peak season, from December to April. The preferred construction staging option at this time is to have two stages, maintaining a single alternating traffic lane throughout construction, except for short duration full road closures (regardless of the Third Crossing opening). In Stage 1, proposed rehabilitation works would be performed on the north side of the bridge allowing traffic on the opposite lane, and inversely for Stage 2. A temporary sidewalk will be required to accommodate pedestrians during Stage 2 as the existing sidewalk will be temporarily dismantled near the trunnion to carry out the work. Cyclists could travel in the single alternating traffic lane or dismount and walk their bike on the sidewalk provided for pedestrians.

## 1 Introduction

The LaSalle Causeway, owned and operated by Public Services and Procurement Canada (PSPC), carries Highway 2 across the Cataraqui River within the City of Kingston, providing a critical transportation link between the downtown area on the west side of the river with the Barriefield/CFB Kingston area on the east side of the river. Approximately 23,000 vehicles cross the Causeway daily. The Causeway consists of five (5) interconnecting structures: The West Bridge (including its west approach), the West Wharf, the Bascule Bridge, the East Wharf, and the East Bridge (including its east approach). The Bascule Bridge also provides marine access to the inner harbour of Kingston, lifting an average of 900 times per year, and access to the southern entrance of the Rideau Canal.

In September 2019, Parsons was retained by PSPC to provide professional engineering services related to the Main Trunnion Bearings Rehabilitation of the LaSalle Causeway Bascule Bridge. The mandate includes the following tasks: a detailed close-up inspection (including ultrasonic thickness testing) of the main trunnion assemblies and adjacent steel members and connections; measuring the dynamic amplification of the bridge during opening and closing of the bridge using strain gauges; a structural analysis of the main trunnion assemblies; development of repair and/or replacement concepts; steel coating requirements; construction staging strategies, including Class 'C' cost and working day estimates; and a traffic impact analysis. This report presents the repair concepts for the bridge components that were found to be overstressed or deficient in the 2020 Detailed Inspection Memorandum and the 2020 Structural Evaluation Report. Mechanical movable bridge specialist engineers from Stafford Bandlow Engineering, a division of Wiss, Janney, Elstner Associates (WJE), have collaborated with Parsons to assess the condition of the pins and to determine if any retrofitting of the pins is required from the remaining service life of 30 years. Finally, this report discusses the steel coating requirements, the construction staging as well as probable construction cost estimate.

## 2 Structure Description

The Bascule Bridge is a single-leaf Strauss heel trunnion bascule bridge, designed by The Strauss Bascule Bridge Co. of Chicago (Figure 1 and Figure 2). Construction of the bridge was completed in April 1917. The structure is supported on two concrete abutments (also known as piers) founded on timber piles (based on available original drawings), the front faces of which are protected with steel sheet piling.

The main leaf truss span of the bridge spans between the East Wharf and West Wharf and consists of a Modified Warren through truss with a span length of 48.77 m (160'). The centre-to-centre truss width is 8.23 m (27') and the centre of bottom chord to centre of top chord height varies from the east to the west end from 6.10 m (20') to 7.92 m (26'). The bridge has a posted vertical clearance of 4.2 m and a vertical clearance above the water of approximately 0.6 m.

The roadway width on the bridge is 7.32 m (24') and carries one eastbound and one westbound vehicular traffic lane on an open steel deck grating. The deck grating is supported by a floor system comprised of transverse sills, nine longitudinal stringers, and transverse floor beams located at each panel point. A 1.2 m (4') wide timber plank sidewalk is cantilevered from the exterior of the south truss.

The fixed tower truss supports the counterweight truss and machinery room. The lower members of the north and south trusses are located directly adjacent to the roadway. The counterweight truss above supports the concrete counterweight.

The top chords, bottom chords, verticals, diagonals, cantilevered sidewalk floor beams, sway bracing and struts, top lateral bracing, fixed tower, counterweight link, operating strut, and counterweight truss members consist of built-up sections of plates, channels, angles, and/or lattice. Repairs carried out under previous contracts have strengthened or repaired some deteriorated members and replaced lattices with cut out steel plates on others.

The concrete counterweight weighs approximately 550 tons (1,220,000 lbs.) and is suspended from the counterweight truss. The counterweight has an internal steel truss structure and is reinforced at the exterior faces by steel bars and wire mesh. There are steel plates mounted on the north and south faces which are secured in place by threaded steel rods.

Two pockets are provided in both the east and top faces of the counterweight, which can accommodate additional dead load required to balance the bridge.

The machinery room containing the span drive machinery (brakes, motors, open gearing, etc.) is located over the roadway and is supported within the fixed tower truss. Access to the machinery room, top of the counterweight, bearings and pins is provided by various catwalks, stairs, and access ladders. The operator’s control house containing the electrical systems for bridge operations is located at the northwest of the structure on the east end of the West Wharf. The building containing the PSPC office and workshop is located on the West Wharf.



Figure 1 – South elevation

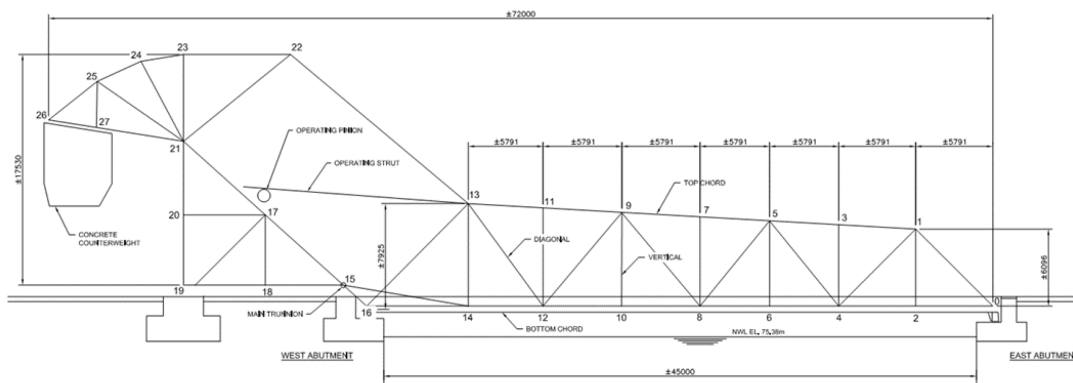

Figure 2 – Dimensions and Truss Member Designation

The main trunnion assemblies consist of 6 truss members: the diagonal 13-16, the strut 14-15, the bottom chord 14-16 (all through-truss members), the fixed diagonal 15-17 and tie 15-18 (both tower truss members) and the post (Figure 3). The main trunnion pin is located at node 15.



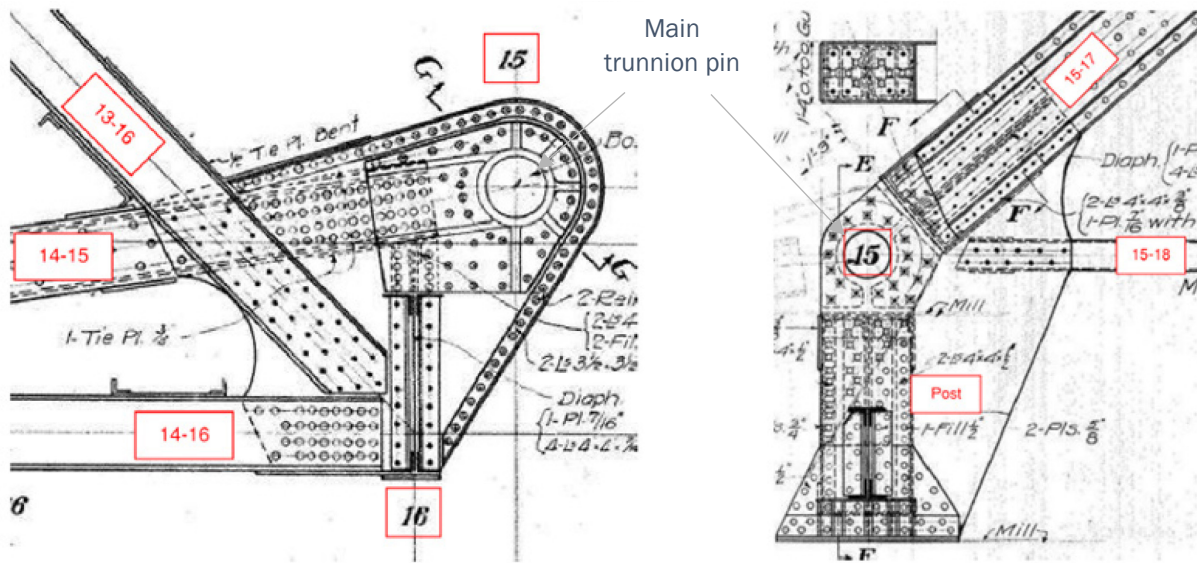

Figure 3 - Main Trunnion Assembly  
(a) Left: Moveable part (b) Right: Fixed part

## 3 Proposed Scope of Work

### 3.1 General

The following works are recommended based on the findings of the 2020 Detailed Inspection Memorandum and the 2020 Structural Evaluation Report, both carried out by Parsons. The latter evaluation was only performed on the four main trunnion gusset plates and on the six connecting members of the main trunnion assemblies.

All other members of the bridge, other gusset plates and all other components are outside the scope of this Concept design report. The following sections summarize the findings of the two studies referenced above and describe the extent and the targeted service life of the proposed strengthening for the connecting members of the main trunnion assemblies (Section 3.2) and the main trunnion gusset plates (Section 3.3). The condition of the pins of the main trunnion assemblies is discussed in section 3.4.

### 3.2 Connecting Members of the Main Trunnion Assemblies

The structural evaluation of the connecting members (Parsons 2020) established that the Posts (see Figure 3) have sufficient capacity (see Figure 4). At the same time, the demand over capacity ratio (D/C), determined for members 15-18 (Ties) is exactly at 1.00, however this ratio becomes much lower for the load cases where wind speed is limited. As such, no strengthening works are proposed for these members.

Furthermore, the evaluation determined that members 13-16, 14-16, 14-15 and 15-17 have insufficient structural capacity and need to be reinforced when the bridge is in the open position. Figure 4 presents an excerpt of the results presented in the structural evaluation report. The scope of work for these four members will consider the reinforcement of the overstressed areas to keep the bridge in service for the next 30 years.

Member	Failure mode	Load combinations per CHBDC		Deviation from CHBDC (limited to 60 km/h winds)
		ULS 1	ULS B1 to B4	ULS B1 to B4
1 DIAGONALS (MEMBER 13-16)	TENSION INTERACTION	0.58	1.64	1.26
	COMPRESSION INTERACTION	0.71	1.10	0.54
2 BOTTOM CHORDS (MEMBER 14-16)	TENSION INTERACTION	0.74	0.84	0.44
	COMPRESSION INTERACTION	0.51	2.11	1.68
3 STRUTS (MEMBER 14-15)	TENSION INTERACTION	N/A	1.06	0.59
	COMPRESSION INTERACTION	0.77	1.87	1.26
4 FIXED DIAGONALS (MEMBER 15-17)	TENSION INTERACTION	N/A	N/A	N/A
	COMPRESSION INTERACTION	0.71	1.62	1.33
TIES (MEMBER 15-18)	TENSION INTERACTION	0.17	1.00	0.59
	COMPRESSION INTERACTION	N/A	0.90	0.37
POSTS (AT NODE 15)	TENSION INTERACTION	N/A	0.76	0.34
	COMPRESSION INTERACTION	0.19	0.81	0.44

Figure 4 – Excerpt from Table 7 of the Structural Evaluation Report (2020) showing D/C ratios for all connecting members

### 3.3 Gusset Plates and Fasteners

As mentioned in the 2020 structural evaluation report, strengthening of the gusset plates is required to:

- Reinforce the areas that are overstressed due to the design loads (see blue areas in Figure 5); and
- Reinforce the areas that are overstressed due to the corrosion (see other blue areas in Figure 6).

Figures 5 and 6 show the expected yielding on the gusset plates as determined using the *von Mises* yield criterion. In addition to the expected yielding areas, areas with significant section losses identified in the 2020 Detailed Inspection Memorandum should be repaired, in order to keep the bridge in service for 30 years.

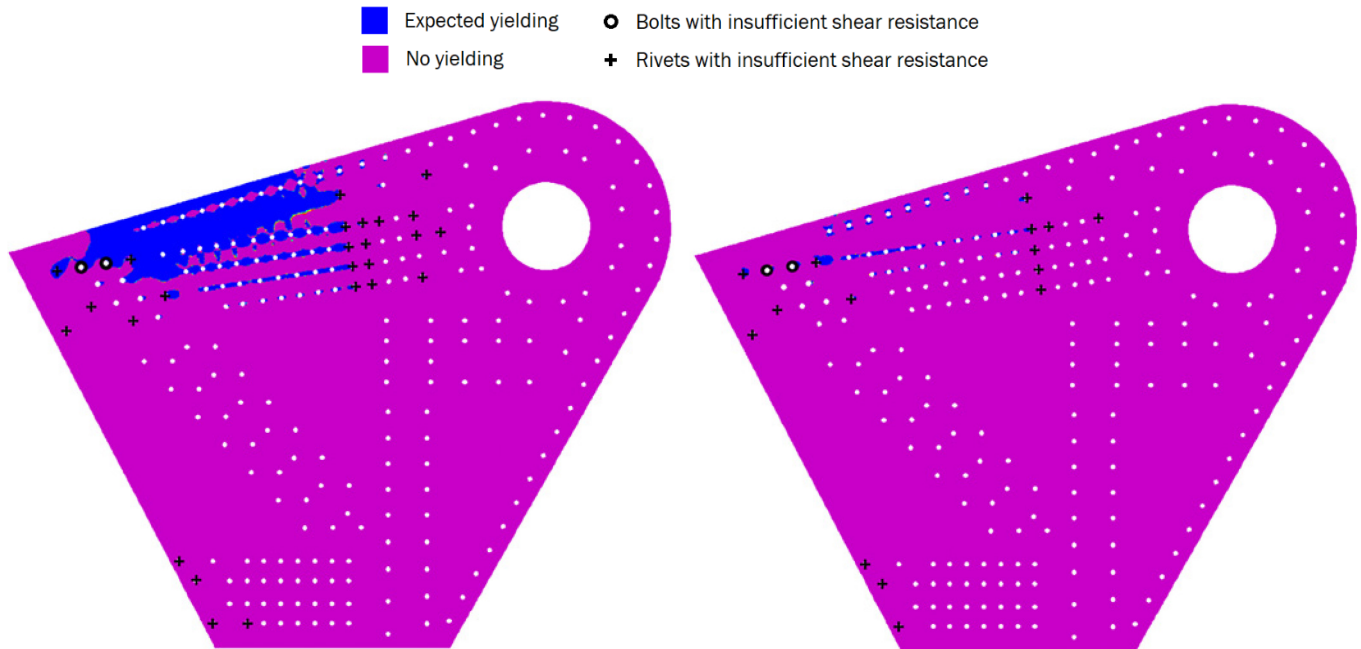

Figure 5 - Gusset plate expected yielding and fasteners with insufficient resistance at undeteriorated state for ULS B1 to B3 <sup>1</sup>  
 (a) Left: with loads taken according to S6-14 (b) Right: with restrictions during bridge operation

<sup>1</sup> Figure 5 is a reproduction of Figure 38 of the 2020 Structural Evaluation report. Refer to this report for more information.

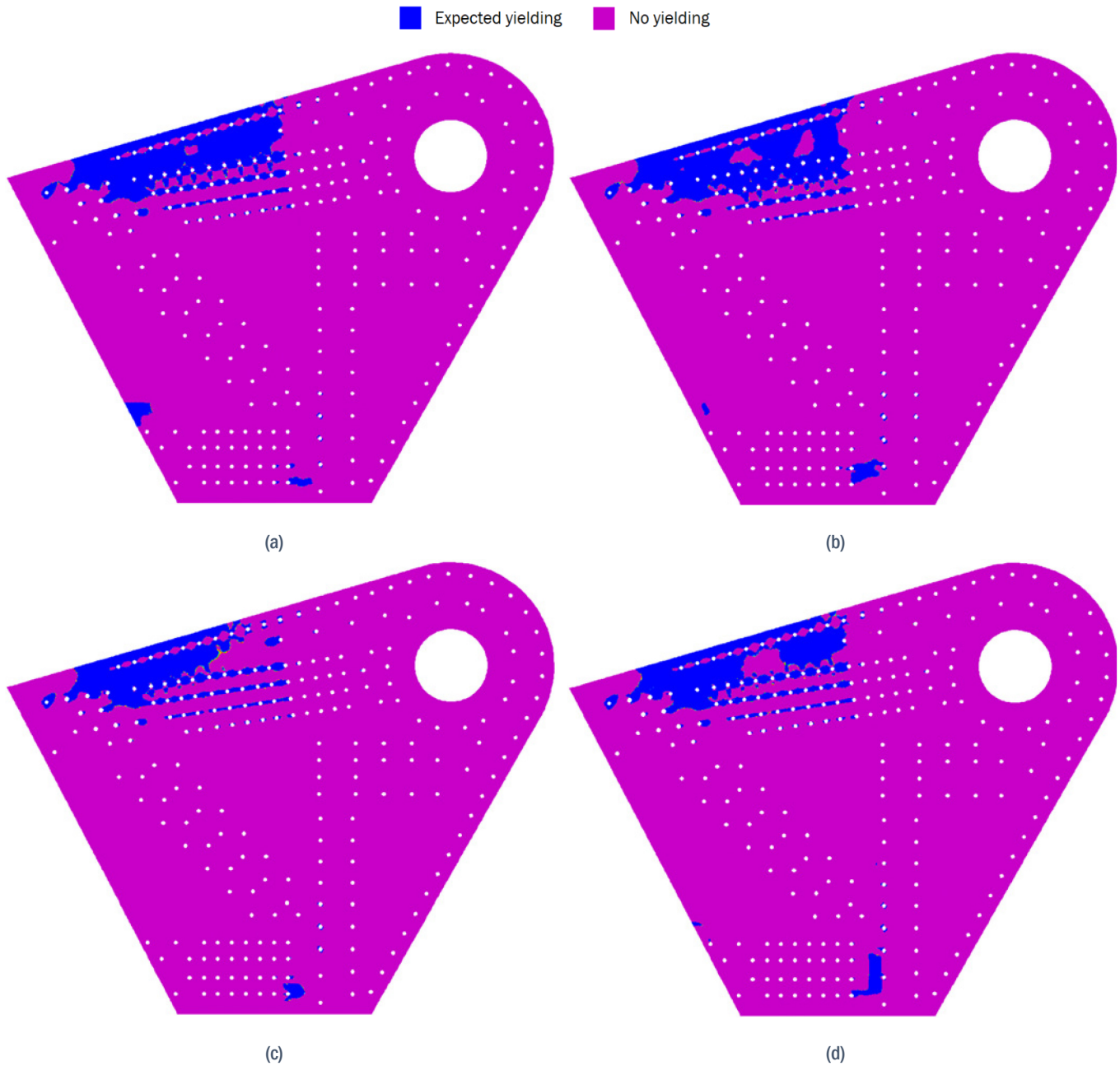

Figure 6 - Gusset plate expected yielding for ULS B1 to B3 according to S6-14 considering deterioration <sup>2</sup>  
 (a) South exterior plate (b) South interior plate  
 (c) North exterior plate (d) North interior plate

The following work is recommended for the main trunnion gusset plates and fasteners:

- Clean, sandblast, strengthen, repair and re-coat the four Main trunnion gusset plates; and
- Replace corroded / loose / identified rivets and bolts.

<sup>2</sup> Figure 6 is a reproduction of Figure 37 of the 2020 Structural Evaluation report. Refer to this report for more information.



### 3.4 Pins of the Main Trunnions

The pins of the main trunnions were evaluated by WJE. Their recommendations are presented in Appendix A. According to WJE, no replacement or work is required on the main trunnion pins for the remaining service life. However, several points should be noted, and their findings are summarized in the following:

- The bearing pressure of the pins exceeds the requirements of the CHBDC for a new design, by 10% in motion and 19% at rest considering the dead load only. Considering the live load when the bridge is at rest, the percentage over allowable is 37%. Considering the operating loads during motion that are based on the restricted wind load, the percentage over allowable is 53%. Therefore, if the pins were replaced using CHBDC requirements, the size of the shaft and bearing would need to be increased;
- The bronze material constituting the bearing bushing isn't explicitly defined by the CHBDC and given the time of manufacture, the physical properties are unknown without removal and testing;
- As such, the most appropriate means of evaluating the condition of the bearing is based on their physical performance, i.e. noise, heat or vibration during operation, and if there is excessive friction;
- Performed past testing using dynamic strain gages indicated that total system friction (which includes trunnion friction) is very low. Furthermore, the pins have been observed during operational tests during the annual CDI without any indications of noise, vibration, or heat up;
- Therefore, no evidence to suggest that replacement of these bearings is warranted, and the main trunnion bearings may remain in service as-is without modification; and
- While the existing bearings appear to have performed well under the current loading, it is not recommended increase the bearing loads beyond the current levels due to the uncertainty about how this bearing material will respond.

## 4 Design Criteria

The design criteria for the rehabilitation work are summarized in Table 1. The criteria shall be revalidated in the detailed design phase, as changes may occur, particularly with regards to other current and future rehabilitation projects for the bridge. Note the identified deviations from the Canadian Highway Bridge Design Code, CSA S6-19 (CHBDC).

Table 1 - Design Criteria for the Rehabilitation of the Main Trunnion Assemblies

<b>1</b>	The structural rehabilitation of the main trunnion assemblies and adjacent steel members and connections will be developed in accordance with the Canadian Highway Bridge Design Code (CHBDC) CSA S6-19 and the current editions of the MTO <i>Structural Manual (SM)</i> , MTO <i>Structure Rehabilitation Manual (SRM)</i> , MTO <i>Structural Steel Coating Manual (SSCM)</i> and TAC <i>Geometric Design Guide for Canadian Roads (GDGCR)</i> .
<b>2</b>	30-year design life is required for the structural rehabilitation.
<b>3</b>	Requirements for steel coating are established to achieve a maintenance free service life of 10 years.
<b>4</b>	For the development of construction staging strategies, long-term traffic disruption shall be limited to single lane closures only. Complete long-term closure of the bridge to vehicular and pedestrian traffic is not permitted; however, regular short-term overnight or weekend complete closures may be required. Furthermore, the bridge shall remain fully operational during the marine navigational season (May to November).
<b>5</b>	The ultimate tensile strength ( $F_u$ ) of the existing rivets will be assumed to be 320 MPa as per Cl. 14.7.4.6 of the CSA S6-19, and the yield strength ( $F_y$ ) and ultimate tensile strength ( $F_u$ ) of the structural steel will be assumed to be 210 MPa and 420 MPa respectively, as per Cl. 14.7.4.2 of the CSA S6-19.

6	<p>The main trunnion pins do not meet the maximum bearing pressure requirements of Cl. 13.7.3.3 of CSA S6-19. However, given its performance history and the on-going rigorous inspection program, the pins will not be replaced but will continue to be monitored.</p>
	<p><b>Design Loads</b></p>
7	<p><u>Special Wind load case <math>W_0</math>:</u></p> <p>Based on Cl. 13.6.4.1 of CSA S6-19, the wind loads for the bridge in the open position should be determined in accordance with Section 3 using 50-year reference wind pressure, but not greater than 450 Pa. For Kingston, Annex A3.1 provides a wind pressure of 465 Pa. Thus, a wind pressure of 450 Pa is retained and a total wind pressure of 2.16 kPa is obtained considering the other coefficients of Section 3 (<math>C_e=1.2</math>, <math>C_g=2.0</math> and <math>C_h=2.0</math>).</p> <p>However, a maximum permissible wind speed of 69 km/h for the bridge operation has been established in 2017 based on the capacity of the existing mechanical system and new motor controls. Therefore, for this structural rehabilitation, the same criteria are used to reduce the extent of the strengthening. Assuming a mean hourly wind speed of 69 km/h, the corresponding total wind pressure is 1.08 kPa using the commentary CA3.1 to derive the reduce wind pressure (240 Pa) and including the other applicable coefficients of Section 3 (<math>C_e=1.2</math>, <math>C_g=2.0</math> and <math>C_h=2.0</math>). Wind speed monitoring equipment shall be installed, operated and maintained to ensure wind speed is below the permissible limit during the operation of the bridge. Moreover, the implication of a wind specialist is strongly recommended at the detailed design phase to ensure a rigorous approach in order to determine the exact pressures on the structure and confirm that the limitation is adequate regarding operational disruptions.</p>
8	<p><u>Special Operation of Machinery load case <math>M_0</math>:</u></p> <p>The maximum force caused by the operation of machinery (<math>M_0</math>) is taken in accordance with CSA S6-19 Cl. 13.7.3.1 (a) and AASHTO LRFD for Movable Bridges Cl. 2.4.1.2.3 which is 150% of the full load motor torque for the service limit state of the machinery design. This corresponds to an unfactored value of 256 kN in the operating struts.</p> <p>Regarding the impact caused by the operation of machinery, CSA S6-19 specified that the <math>M_0</math> force should be increased by 100%. The possibility to deviate from the Code has been looked and it is decided to keep as specified by CSA S6-19, as recommended by WJE (see WJE's recommendations in Appendix A).</p>
9	<p><u>Special Operating Impact load case <math>I_0</math>:</u></p> <p>An operating impact factor of 20% of the dead load is considered, in accordance with CSA S6-19 Cl. 13.6.10.2, as recommended by Parsons structural evaluation report dated May 2020.</p>
10	<p><u>Other loads:</u></p> <p>The other loads considered for the rehabilitation include relevant dead and live loads, as well as construction loads and construction staging. For live loads, the CL-625-ONT truck is considered, as well as the pedestrian load on the sidewalk.</p> <p>Seismic loads and vessel collision loads are not considered.</p>
11	<p>Factors and combinations:</p> <ul style="list-style-type: none"> <li>• Load factors for the load combination ULS 1 are taken in accordance with Section 3 of the CSA S6-19, as specified in Cl. 15.5.2.1 of CSA S6-19.</li> <li>• Special load factors and combinations for bascule bridges (ULS B1 to ULS B5) are considered in accordance with Cl. 13.6.10.2 of the CSA S6-19.</li> </ul>

Construction will be carried out in accordance with the latest version of PSPC's National Master Specification (NMS) and reference applicable Ontario Provincial Standard Specifications (OPSS) and Ontario Provincial Standard Drawings (OPSD). Materials will be sourced from the MTO's Designated Sources of Materials (DSM) list, if applicable.

## 5 Rehabilitation Concepts and Construction Staging

This section presents the proposed rehabilitation concepts and construction staging strategies.

It should be noted that the replacement of the bridge is not considered in this study, as our understanding is that a full replacement of the bridge is not considered by PSPC in the short term.

### 5.1 General

---

The replacement of the connecting members and the main trunnion gusset plates are excluded from the proposed concepts because it is not necessary to achieve the design criteria and it is more complex and riskier than simply strengthening. In order to completely replace a connecting member or a gusset plate, one of the following two methods would need to be used: (1) completely close the bridge to vehicular traffic and remove or support the counterweight; or (2) install temporary members to create an alternative load path while replacing the deteriorated or overstressed parts. Either of these options is difficult, time-consuming, and costly and would result in significant traffic disruption. Also, the general condition of the members and gusset plates is still in reasonably fair condition that can accommodate the connection of a new material to it. For these reasons, strengthening is preferable to replacement.

It should be noted that the strengthening design will likely be influenced by the special load cases considered, which were explained in Section 4. One of the important recommendations from the 2020 Parsons Structural Evaluation Report is to consult a wind specialist during detailed design to refine the wind loads and determine how frequent as well as how long the shutdowns would be due to limiting the wind speed for bridge operation. Therefore, the strengthening will be ultimately dependent on the assessed wind loads and on the measures that will be implemented to ensure restrictions are in place for the operation of the bridge under wind loads. The installation of wind speed monitoring equipment was also strongly recommended in the 2020 Parsons Structural Evaluation Report, not only for the structural resistance of the bridge, but also because the 2017 Bridge motor and drive rehabilitation design was also based on a reduced operational wind speed.

#### 5.1.1 STRUCTURAL STEEL COATING SYSTEM

Prior to coating operations, existing structural steel shall be cleaned to SSPC-SP11 Power Tool Cleaning to Bare Metal using abrasive blasting and, if necessary a bristle blaster tool (MBX or equivalent), which will require a Class 1A containment system (i.e. full enclosure with negative air pressure) according to SSPC-Guide 6 Guide for Containing Surface Preparation Debris Generated During Paint Removal Operations.

A three-coat system shall be used to match the existing system. Paint for existing and new steel shall be comprised of the following coating system components known to be compatible with the existing bridge coating system. Other products equivalent to those listed could be accepted if proved to be compatible with existing system. The recommended system is the following:

- Primer Coat 1: Carbozinc 11HS to minimum dry film thickness of 75 µm and to a maximum of 150 µm;
- Intermediate Coat 2: Carboguard 893 to minimum dry film thickness of 100 µm; and
- Topcoat 3: Carbothane 134HG to a minimum dry film thickness of 50 µm.

As explained in Section 5.3.3, it is recommended to add a fourth clear coat on the interior faces adjacent to the roadway to aid in long-term protection of the steel members. On the faying surfaces of the existing and the new steel, only a prime coat should be used.

It is recommended that caulking is applied to all edges except downward facing edges of joints and connections between all mating members using a silicone-based sealant. Caulking shall be applied after the finish coat has cured and shall extend downward at each end of horizontal/inclined seals.

It is not known if lead or asbestos are present in the existing coating system of the main trunnion assemblies with concentrations exceeding the acceptable limit defined in the applicable regulations. Therefore, sampling and testing the existing coating system is recommended before preparing the Contract Documents for the Main Trunnion Rehabilitation. As steel repairs will likely be performed in the meantime (Project No. R.097736.002), it is recommended to perform the sampling and testing prior to these works and confirm lead and asbestos concentrations.

### 5.1.2 TEMPORARY REMOVALS

It is anticipated at this stage that it will be necessary to temporarily remove and reinstate sections of the deck grating, curb, and top of abutments, as shown in red in Figure 7, to permit work on the interior trunnion plates and members. It should be noted that parts of the abutment were temporarily removed in 2009 to perform the welding of the triangular reinforcement plate on the interior trunnion plates. The area marked in red in Figure 7 is for reference only, and the exact dimensions will be determined by the contractor according to the construction methods that will be adopted.

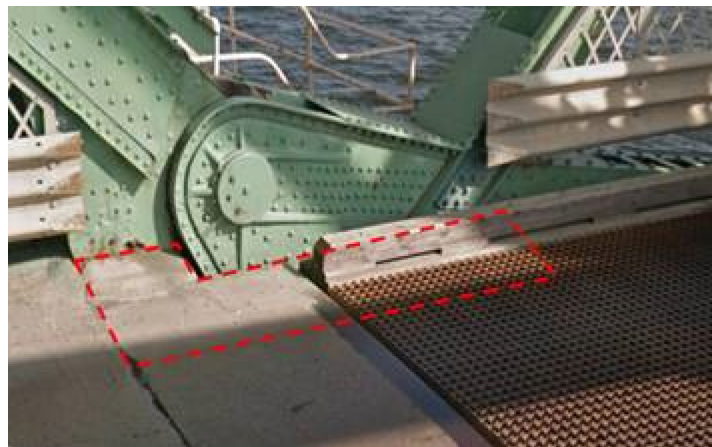

Figure 7 - Temporary removal on the inner side of the main trunnions

On the south side of the bridge, the sidewalk needs to be removed locally, in the area of the main trunnion, to permit work on the exterior side of the exterior gusset plate and connecting members of the south trunnion. To accommodate pedestrians, it is recommended to install a temporary sidewalk similar to the one installed during the last major rehabilitation contract in 2010 (Figure 8). However, it will not be necessary to install it over the entire length of the bridge but most likely only over a section around the main trunnion.





Figure 8 - Temporary removal of the sidewalk (photo from 2010 rehabilitation)

### 5.1.3 IMPLICATIONS ON THE BRIDGE BALANCE

The proposed repairs will add extra weight to the members, so a bridge balancing check should be performed during detailed design to check the effects on the balancing of the additional dead loads. Consequently, some drive tuning adjustments would be possibly needed during construction.

## 5.2 Connecting Members of the Main Trunnion Assemblies

---

### 5.2.1 GENERAL

Since the goal of the rehabilitation is to extend the service life of the main trunnions and connecting members by 30 years, it is important to clean and paint these components, including areas that are generally not normally accessible. This will lengthen the duration of the work on each member, but it is the ideal opportunity to extend their lifespan. The following two steps will apply to all the members to be reinforced:

- All members shall be cleaned and sandblasted prior to reinforcement in order to remove the current paint and any corroded material (this includes the inside of closed sections such as struts 14-15); and
- Reinforced members shall be coated with at least a three-coat system, the same color as the original and with a system compatible with the existing.

Note that all members are identified by the nodes at their ends (e.g. 13-16) and that there are always two, corresponding to the north and south sides of the bridge.

## 5.2.2 DIAGONALS 13-16

### 5.2.2.1 Capacity

These members have insufficient capacity in tension ( $D/C = 1.64$ ) and in compression ( $D/C = 1.10$ ) when the bridge is in the open (raised) position. The capacity is sufficient when the bridge is in the closed position and open for vehicular traffic ( $D/C = 0.71$ ).

Moreover, the lacings (lattice) are overstressed and were found to have a less than optimal detailing as the centroidal axes of the lacing members at their ends do not intersect at a common point causing a connection eccentricity and additional stresses in the channels.

Finally, at the intersection with member 14-15, an area of significant localized section loss was found in the two original channels. This section loss approaches 25%, but it has been compensated by a prior strengthening detail shown in Figure 10.

### 5.2.2.2 Rehabilitation

The following work is recommended and is shown on Figure 9:

- Replacement of the top and bottom lacing with perforated cover plates;
- Replacement of rivets with bolts when rivets must be removed for the replacement of components; and
- Installation of additional plates on the exterior face of the channels at discontinuities of the new perforated plates and at both ends.

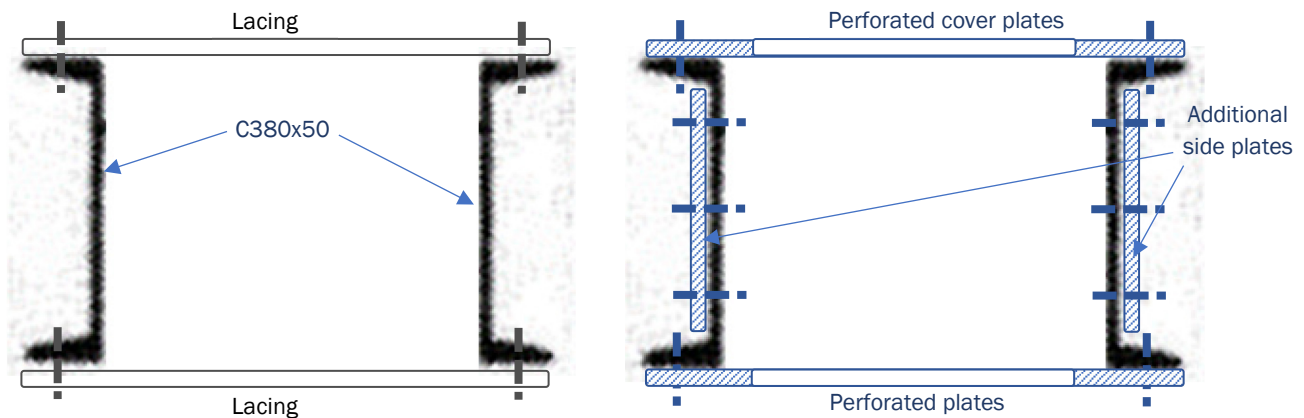

Figure 9 – Existing (left) and reinforced (right) sections of 13-16 members

Since these members are mainly in tension, the new perforated cover plates alone cannot be efficient for these loads over the entire length of these members. As members 14-15 intersect members 13-16 at deck level and therefore, the cover plates have to be interrupted. The perforated plates will have to stop before nodes 13 and 16 and most likely at the connection with the bottom chord of the portal (i.e. the transverse truss connecting the two members 13-16 in their upper portion to stabilize them laterally). These are the locations where the additional side plates are required to increase capacity under tension loads.

At node 16, where the diagonal members are attached to the gusset plates., the members are severely corroded, and a plate has been previously installed to reinforce this area (see Figure 10). Since new side plates will be installed, the existing small reinforcing plates are no longer required and will be removed.

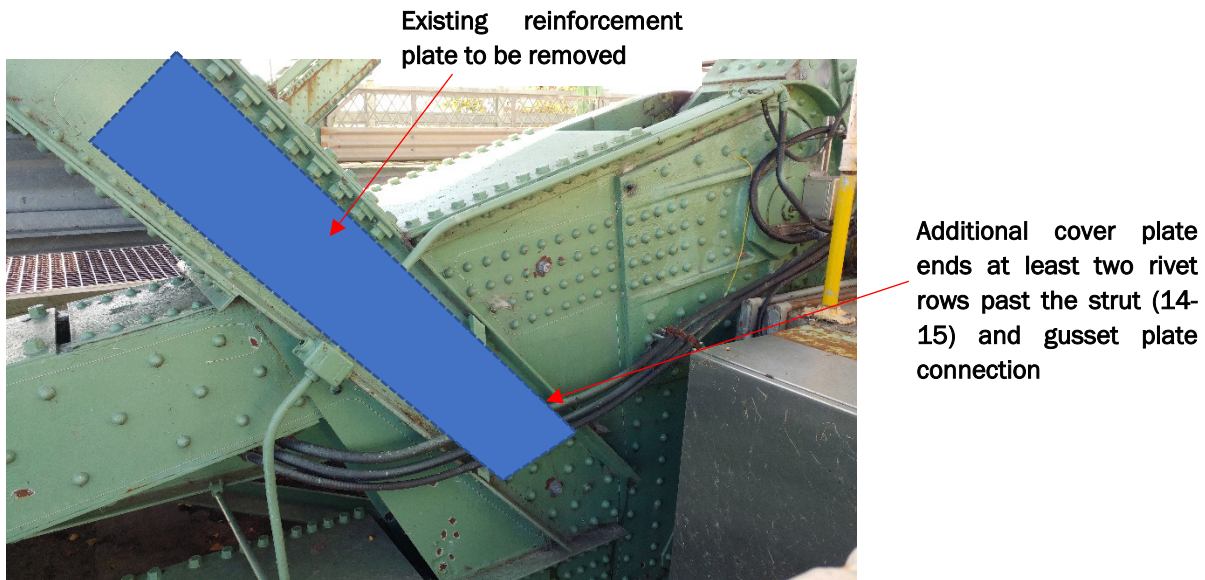

Figure 10 - Reinforcing side plate at node 16

### 5.2.2.3 Constructability Constraints

Under dead loads, members 13-16 are in tension. This is true whether the bridge is in the open (raised) position or is in the closed position. However, when the bridge is open to vehicular traffic, live loads induce compression in these diagonals and the total factored force becomes in compression. While the D/C ratio under ULS1 was found to be 0.71, this value is only valid if each of the individual channels of this section is properly braced.

If during the work, the bridge can be closed to vehicular traffic for a sufficient period of time, the removal of the existing lacing and the installation of the new perforated cover plates and additional side plates can be performed without any temporary reinforcement measure. On the other hand, if road traffic is maintained, removal of the lacings only can be performed if temporary plates are installed on the inside of the members to reduce their weak-axis unbraced length and maintain the stability of the members in compression (see Figure 11). There is no need to remove the temporary plates after the repair work if they are properly protected against corrosion, as they are detailed to ensure they do not hold water and they do not interfere with the passage of cables or other electrical or mechanical components of the bridge.

It should be noted that the temporary plates shown on Figure 11 are only one possible option and alternative bracing options can be developed during the detailed design stage.

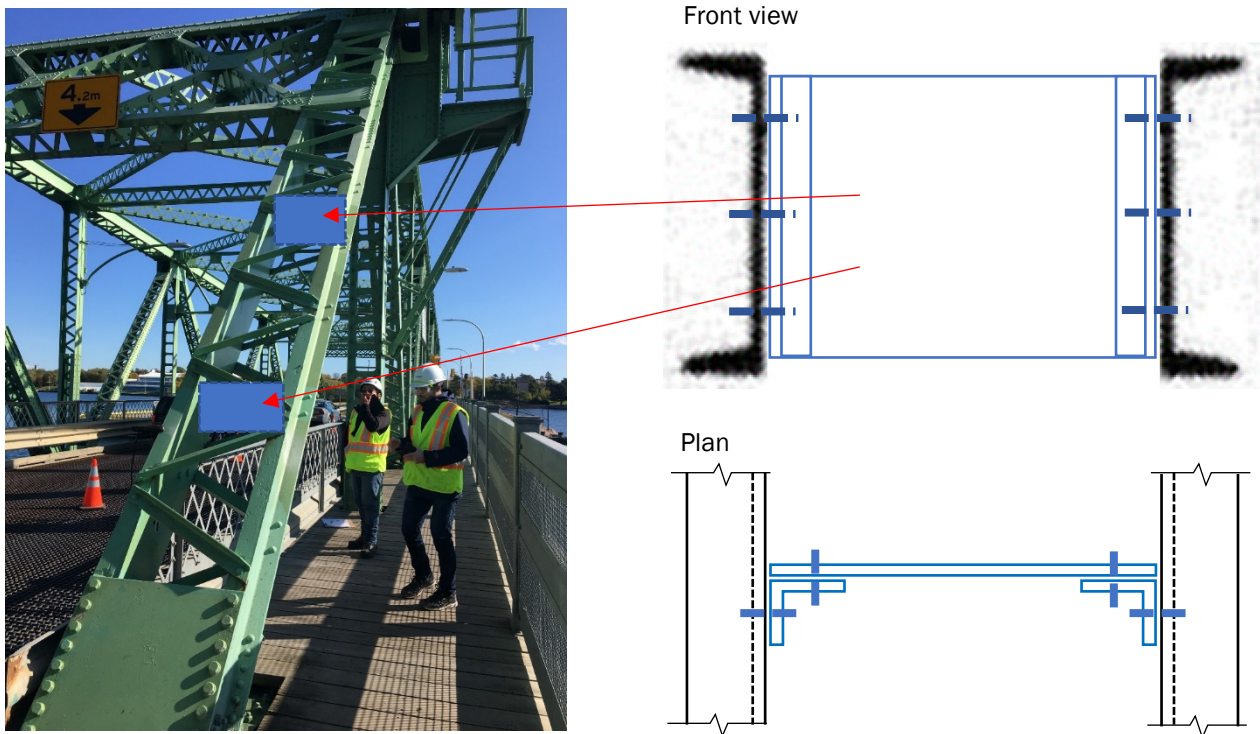

Figure 11 - Intermediate bracing of two existing channels if work is performed with vehicular traffic over the bridge

### 5.2.2.4 Alternative Options

One disadvantage of the proposed method of rehabilitation is that the perforated cover plates would reduce the transparency of member 13-16 which would locally reduce the visibility on the sidewalk. To avoid this issue, it would be important, during detailed design, to make sure the openings of the cover plates on both sides of this inclined member align horizontally together in a way that a pedestrian will be able to see through the member.



An alternative to the perforated plates would be to replace the existing lacing with a wider lacing that attaches to the channels with a regular pattern without an eccentric connection, meaning the centerline of each lacing intersects at a single point (see Figure 12).

However, it is unclear that the visibility would be improved significantly with wide lacing compared to perforated plates. A comparison can be made during detailed design when the exact plate sizes would be determined.

At this concept stage, the perforated plate solution appears to be more convenient if the perforated areas are properly aligned.



Figure 12 - Wide lacing alternative

### 5.2.3 BOTTOM CHORDS 14-16

#### 5.2.3.1 Capacity

The bottom chords have insufficient capacity in compression when the bridge is in the open position ( $D/C = 2.11$ ). However, their capacity is sufficient when the bridge is in the closed position and open for vehicular traffic ( $D/C = 0.74$ ).

In the open position, the  $D/C$  ratio of member 14-16 exceeds 2.0 at the location where this member intersects the struts (members 14-15). At this location, close to node 14, the two channels of 14-16 are unsupported over a length of approximately 2.2 m as the top cover plate is interrupted to allow the passage of member 14-15 (see Figure 10). Elsewhere, even if the section can be considered braced, the capacity of the member stays insufficient with a  $D/C$  ratio of 1.65.

#### 5.2.3.2 Rehabilitation

The following work is recommended:

- Replacement of the top and bottom perforated cover plates with thicker plates and smaller openings to fully comply to the CHBDC requirements and to add compression capacity;
- Replacement of rivets with bolts when rivets must be removed for replacement of components;
- Provide continuity between the perforated cover plates and the main trunnion gusset plates by installing angles that directly connect the top cover plate to the outside of the gusset plates to ensure an efficient load transfer

(this reinforcement would be perpendicular to the one illustrated in red in Figure 20 and would be on the outside to avoid conflict);

- Installation of additional plates on the exterior face of the channels (see Figure 14); and
- Installation of two or more permanent diaphragms on the inside of the members to reduce their weak-axis unbraced length close to node 14, where no perforated plates can be installed at the top of the section.

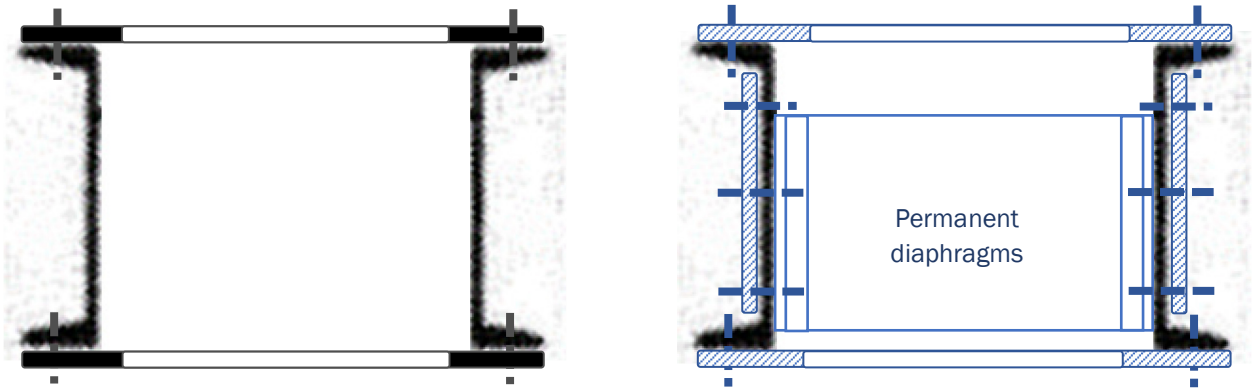

Figure 13 – Current (left) and reinforced (right) sections of 14-16 members

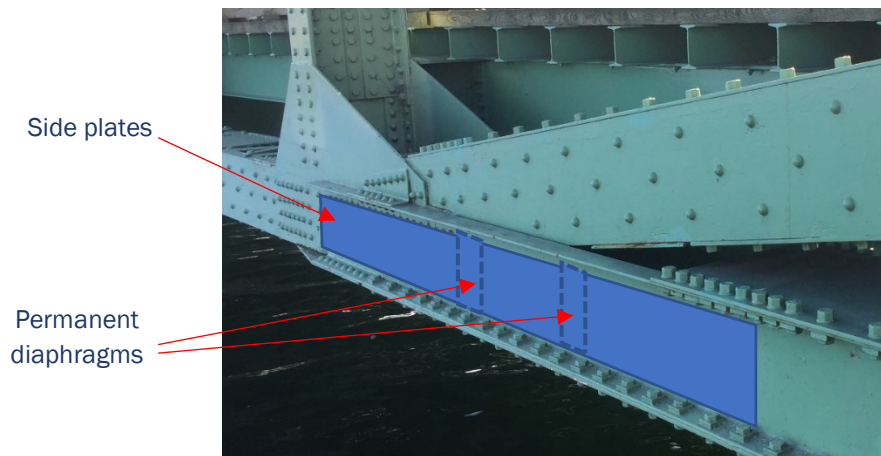

Figure 14 – Position of permanent diaphragms and side plates close to node 14

### 5.2.3.3 Constructability Constraints

The bottom chords are in compression for any position of the bridge (open or closed) and even if only dead loads are applied. Removal of the existing perforated plates can only be performed if temporary diaphragms are installed on the inside of the members to reduce their weak-axis unbraced length as described in Section 5.2.2.3.

## 5.2.4 STRUTS 14-15

### 5.2.4.1 Capacity

The members have insufficient capacity in tension ( $D/C = 1.06$ ) and in compression ( $D/C = 1.87$ ) when the bridge is in the open position. However, their capacity is sufficient when the bridge is in the closed position and open for vehicular traffic ( $D/C = 0.77$ ). Furthermore, the tension capacity is sufficient when reduced wind load is considered.

### 5.2.4.2 Rehabilitation

The following work is recommended:

- Replacement of the existing top and bottom perforated cover plates with thicker plates to add compression capacity;
- Replacement of rivets with bolts when rivets must be removed for replacement of components; and
- Addition of angles on the interior face of both channels at both ends to increase tension capacity where the perforated cover plates stop.

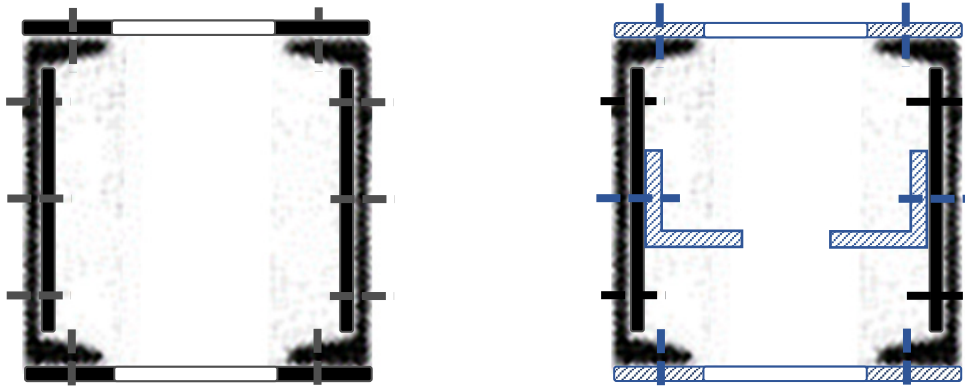

Figure 15 – Current (left) and reinforced (right) sections of 14-15 members

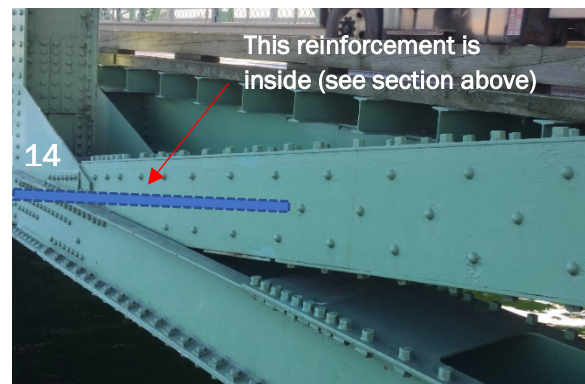
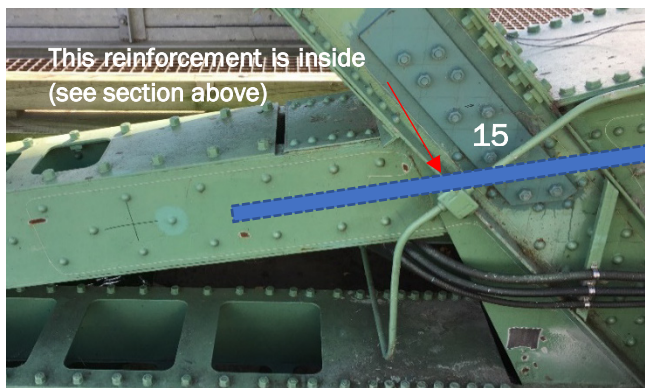

Figure 16 – Position of angles at the connections with nodes 14 (right) and 15 (left)

### 5.2.4.3 Constructability Constraints

The removal of the existing perforated plates can only be performed if temporary diaphragms are installed on the inside of the members to reduce their weak-axis unbraced length as described in section 5.2.2.3.

The addition of the angles only requires the removal of one row of rivets without any temporary reinforcement measures. Nevertheless, it is important to field measure precisely the position of the rivets before and in the area of attachment of the struts to the gusset plates (nodes 14 and 15), to ensure that drilling of new holes is not necessary.

It is important that the angles are compatible with the type of reinforcement chosen for the main trunnion gusset plates. To ensure this, the angles may have to be positioned differently or even replaced by plates.

## 5.2.5 FIXED DIAGONALS 15-17

### 5.2.5.1 Capacity

The members have insufficient capacity in compression when the bridge is in the open position ( $D/C = 1.62$ ). Their capacity is however sufficient when the bridge is in the closed position and open for vehicular traffic ( $D/C = 0.71$ ).

### 5.2.5.2 Rehabilitation

The following work is recommended and is shown on Figure 17:

- Replacement of the existing lacing with new perforated top and bottom cover plates to add compression capacity; and
- Replacement of rivets with bolts when rivets must be removed for replacement of components.

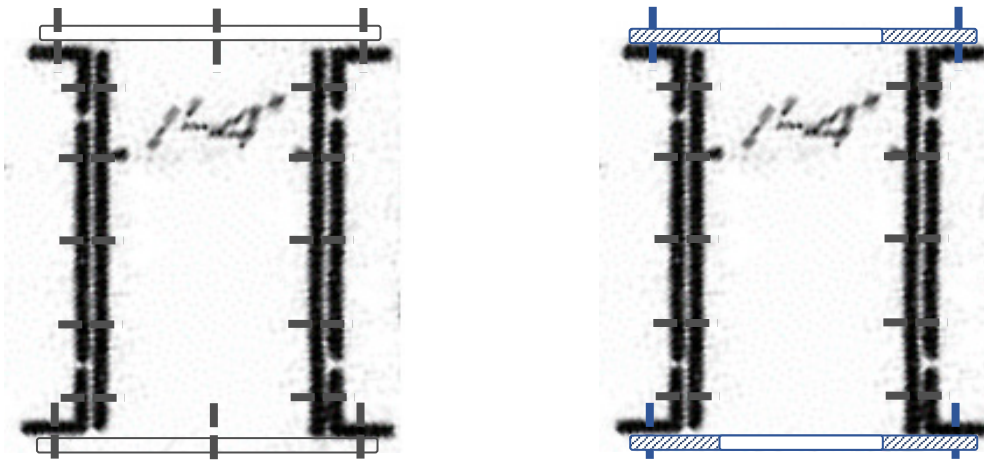

Figure 17 - Current (left) and reinforced (right) sections of 15-17 members

### 5.2.5.3 Constructability Constraints

The removal of the existing perforated cover plates only can be performed if temporary diaphragms are installed on the inside of the members to reduce their weak-axis unbraced length as described in Section 5.2.2.3.

As described in section 5.2.2.4, one disadvantage of the proposed method of rehabilitation is that perforated cover plates would reduce the transparency of the members, which may cause personal security issues due to reduced visibility on the sidewalk. Similar measures (as identified in Section 5.2.2.4) should be taken at the detailed design stage to overcome the visibility issue.

Special attention should be paid to the steps installed on these members which are used to access the mechanical room.

## 5.3 Gusset Plates and Fasteners

This section presents the design concepts for the rehabilitation of the main trunnion gusset plates. As mentioned previously, the strengthening is preferable over the replacement of the whole plate, which is deemed unnecessary considering that only localized overstresses were found in well identified areas.

Before any strengthening work, a complete cleaning by sandblasting should be performed and a primer coat applied.

As a general approach for the strengthening, it is preferable to strengthen only one side of the same plate rather than both sides to be able to inspect the plate in the future from the other side.



As explained in Section 3.3, the design concepts are separated into the three following categories:

- Strengthening in overstressed areas due to design loads, i.e. not caused by corrosion;
- Strengthening in overstressed areas caused by corrosion; and
- Other strengthening / repairs due to corrosion.

### 5.3.1 STRENGTHENING IN OVERSTRESSED AREAS NOT CAUSED BY CORROSION

#### Strengthening Type A1

This strengthening aims to reinforce the area located between the intersection of diagonal 13-16 and strut 14-15 and the trunnion pin, which was identified by the structural evaluation as overstressed in an undeteriorated state. Figure 18 shows the location of the proposed strengthening.



Figure 18 – Gusset Plate Strengthening Type A1  
(a) Left: View from inside the trunnion (b) Right: View from outside.

Description:

- Add two bolted angles that are placed on the inner side of the channels of the strut 14-15 (Figure 18 (a)).
- The angle extends from the intersection with the diagonal 13-16 to the connection with the collar plate (Figure 18 (b)).
- This strengthening applies for all four gusset plates.
- Note that the angles can also be substituted with plates for constructability purposes. This will be determined in the detailed design phase. Moreover, as this strengthening also reinforces strut 14-15, it will also be investigated to determine, if these angles or plates can be extended on the member to ensure a continuity at the connection gusset-strut and therefore replace the strengthening proposed in Figure 16 (left).

Construction staging:

- Remove the rivets located in the lower row outlined in red in Figure 18 (b) and replace each rivet with a high-strength bolt.
- Take detailed measurements of bolt locations, for example by inserting a plexiglass panel on the inside and marking them.



- Drill the holes in the angle according to the measured pattern.
- Install the angle on the inner side of the strut 14-15, then the nuts and tighten the bolts.
- Repeat for the top row.
- Repeat for the other gusset plates.

Alternative considered (**Strengthening Type A2**):

- Add a plate on the outside of the gusset plate, in the area of the connection with the strut 14-15 (Figure 19).
- This plate should extend to the upper edge on the gusset and be bolted over the existing edge angle as shown in red in Figure 19 (a).
- As the edge angle is riveted on the gusset plate, a shim plate (in blue) will be required on the surface of the gusset plate to create a surface flush with the edge angle, permitting installation of the second plate (in red) over the edge angle, as shown in Figure 19 (b).
- This alternative permits the strengthening, and better protection for durability purposes, of the area at the upper edge of the gusset plate, with access from the outside that is much easier than from the inside of the member. However, it does not strengthen the area of the gusset plate that is at the intersection of the diagonal 13-16 and the strut 14-15. Therefore, the proposed strengthening shown in Figure 18 is more favorable and it is our recommendation, because it creates a continuity on the gusset upper edge and transfers the forces directly to the collar plate.

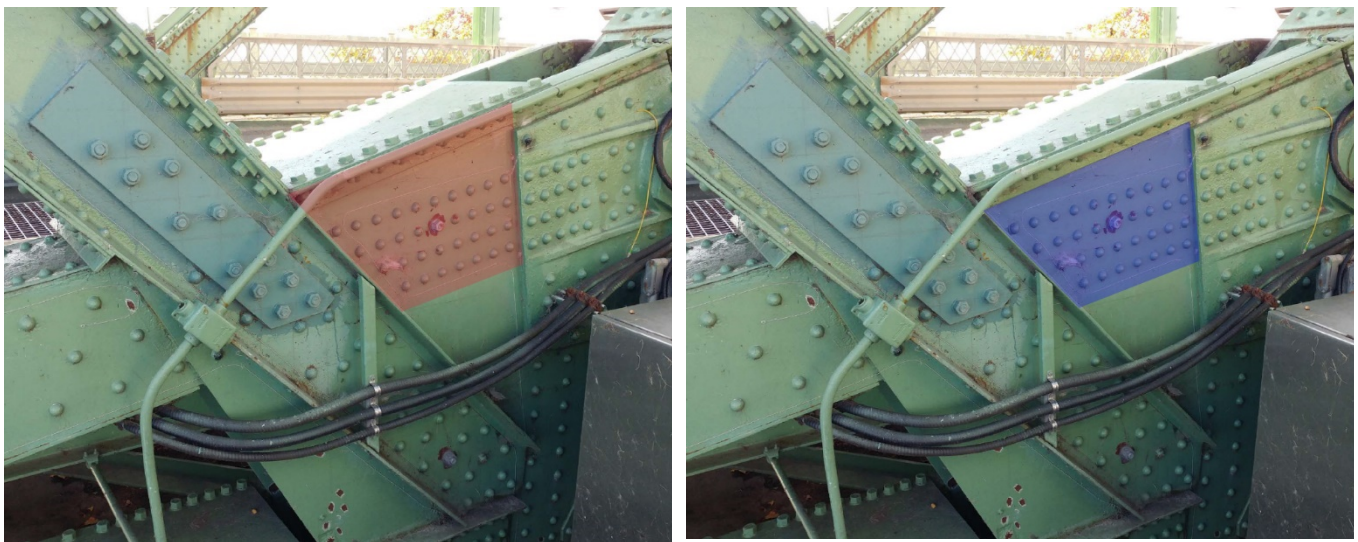

Figure 19 –Gusset Plate Strengthening Type A2 Alternative  
 (a) Left: Plate extending to the edge angle (b) Right: Plate serving as a shim placed first

### 5.3.2 STRENGTHENING IN OVERSTRESSED AREAS CAUSED BY CORROSION

#### Strengthening Type B

This strengthening aims to reinforce the area located at the edge of the gusset plate just above the connection with the bottom chord 14-16. This area was identified by the structural evaluation as overstressed due to the reduced thickness caused by the corrosion, for the four gusset plates. Figure 20 shows the location of the proposed strengthening. Figure 20 shows the exterior gusset plate of the north trunnion at foreground and the three cables at the top are the same that the ones shown in Figure 18 and Figure 19.



Figure 20 - Gusset Plate Strengthening Type B

Description:

- Add one bolted angle that is placed on the inner side of the gusset plate, along the edge of the gusset.
- The angle shall cover the corroded area and extend to the centerline of the bottom chord 14-16.
- This strengthening is to be implemented for all four gusset plates.
- Note that the angles can also be substituted with plates for constructability purposes. This will be determined in the detailed design phase.

Construction staging:

- Remove the two rivets located in the connection between the gusset plate and the bottom chord 14-16 (not shown on Figure 20) and replace each of them with a bolt.
- Drill two aligned holes above the corroded area in the gusset plate.
- Install two bolts in the drilled holes, the angle on the inner side of the gusset plate, the nuts and tighten the bolts.
- Note that the strengthening of the bottom chord 14-16 (not shown in Figure 20 but discussed at Section 5.2.3) should be done at the same time.
- Repeat for the other gusset plates.

Note this area has also been identified by the 2019 Steel Repair Project No. R.097736.002 to be repaired. Small cracks have been detected in the north plate of the south trunnion and it is planned to remove the crack by grinding a radius, thereby minimizing stress concentrations. Therefore, the rehabilitation should coordinate with the 2020 Steel Repair Contract to design the strengthening and minimize the interventions on the gusset plates.

**Strengthening Type C**

This strengthening aims to reinforce the area located between the connection of the bottom chord 14-16 and the interior diaphragm in the gusset plate. This area exhibits significant corrosion and localized perforations and was identified by the structural evaluation as overstressed due to the reduced thickness caused by the corrosion for the four gusset plates. Figure 21 shows the location of this strengthening.





Figure 21 - Gusset Plate Strengthening Type C  
 (a) Left: View from inside the trunnion (b) Right: View from outside

Description:

- Add one plate that is placed on the inner side of the gusset plate, as shown in red in Figure 21.
- This plate shall cover the corroded/perforated area between the end of the bottom chord 14-16 and the connection with the floorbeam / interior diaphragm.
- A shim plate (in blue) should be placed first against the gusset plate to create a surface flush with the angle of the interior diaphragm, permitting installation of the new plate in red.
- This strengthening applies for the four gusset plates.

Construction staging:

- Cut the end of the bottom flange of the interior diaphragm to allow the installation of the plate.
- Remove the existing fasteners (typically six fasteners in the bottom chord connection and three in the interior diaphragm connection) and replace them with bolts.
- Add the shim and the plate on the inner side of the gusset plate, the nuts and tighten the bolts.
- Repeat for the other gusset plates.

Note this area has also been identified by the 2019 Steel Repair Project No. R.097736.002 to be repaired. Small cracks and perforations have been detected in three gusset plates and it is planned to remove the cracks by grinding a radius, thereby minimizing stress concentrations. Therefore, the rehabilitation should coordinate with the 2019 Steel Repair Contract to design the strengthening and minimize the interventions on the gusset plates.

### 5.3.3 OTHER STRENGTHENING DUE TO CORROSION

#### Strengthening type D

This strengthening aims to reinforce the area located in the triangle formed by the diagonal 13-16 and the interior diaphragm connection. This area exhibits high stresses and significant corrosion in both interior gusset plates. It is not yielding according to the structural evaluation (stress in this region reaches 178 MPa<sup>3</sup> which gives a D/C ratio of 0.94), but strengthening is recommended to provide a 30-year service life of the gusset plates. Figure 22 shows the location of this strengthening.



Figure 22 - Gusset Plate Strengthening Type D  
(a) Left: View from inside the trunnion (b) Right: View from outside

#### Description:

- Add a plate that is placed on the inner side of the gusset plate as shown in red in Figure 22.
- This plate shall cover the corroded area of the interior gusset plate above the diagonal 13-16.
- A shim plate (in blue) should be placed first against the gusset plate to create a surface flush with the angle of the interior diaphragm, permitting installation of the new plate in red.
- This strengthening applies for the interior gusset plates of the south and north trunnions.

#### Construction staging:

- Remove the existing fasteners (typically three fasteners in the diagonal connection and four in the interior diaphragm connection) and replace them with bolts.
- Add the shim plate and the plate on the inner side of the gusset plate, the nuts and tighten the bolts.
- Repeat for the other gusset plate.

<sup>3</sup> Refer to Table 8 of the 2020 Structural Evaluation report.

### Strengthening Type E

This strengthening aims to repair the connection between the bottom chord 14-16 and the gusset plate for the north interior trunnion plate. This connection exhibits significant corrosion with very severe section loss of several rivet heads. Figure 23 shows the location of this strengthening and identifies examples of rivet heads with very severe section losses.



Figure 23 – Significant corrosion on the bottom chord connection of the south side of the north interior plate

#### Description:

- Replace all the rivets connecting the member to the bottom chord channel web.
- This repair only applies for the interior plate of the north trunnion.

#### Construction staging:

- Remove one existing rivet at a time and replace it with a new bolt.
- Repeat for all the fasteners of the connection.
- This strengthening should be done at the same time than the strengthening Type B and the strengthening of the bottom chord 14-16 (Figure 9).

### Strengthening Type F

This strengthening aims to repair the connection between the strut 14-15 and the gusset plate for the interior plate of the south trunnion. This connection exhibits significant corrosion with severe section loss of several rivet heads. Figure 24 shows the location of this strengthening.



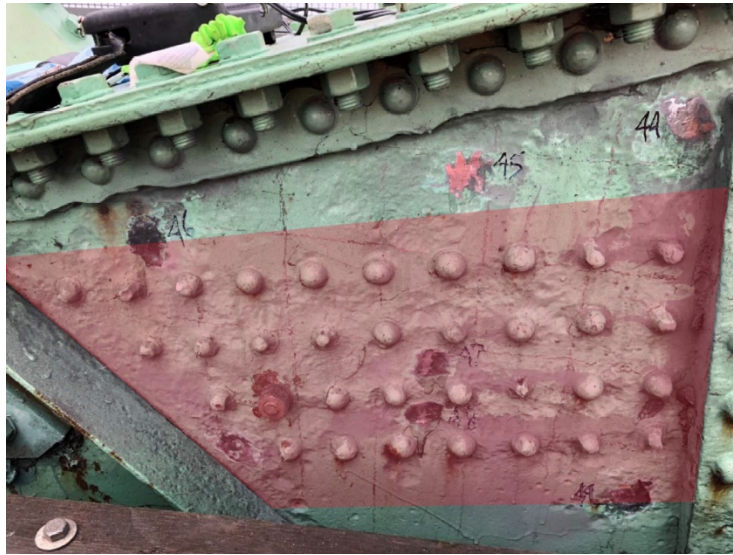

Figure 24 - Gusset Plate Strengthening Type F

Description:

- Replace all the rivets of the group that connect the strut to the gusset plate (this does not apply to the group of rivets that connect also the collar plate at the end of the strut).
- Add a sacrificial plate to protect the gusset plate against further deterioration in this area.
- This repair only applies for the south interior plate.

Construction staging<sup>4</sup>:

- This strengthening should be done at the same time than strengthening Type A, as strengthening type A and type F share the same fasteners (Type A is inside the gusset and type F is outside).
- Remove one existing rivet at a time and replace it with a special bolt or a hole-alignment pin. The pattern and the number of the special bolts and hole-alignment (drift) pins will be determined in detailed design. The special bolts should have a nut which has a smaller diameter and a longer height compared to a regular nut for A325/A490 bolts. Special bolts should be tightened to transfer the loads from the strut 14-15 to the gusset plate.
- Add the sacrificial plate on the north side of the south interior gusset plate. This new plate should have oversized holes at the location of the special bolts, so that the special nuts pass through it and that a new plate can be placed in contact with the gusset plate.
- Remove one hole-alignment pin at a time and replace it with a bolt and a nut.
- Once all hole-alignment pins (but no special bolts) have been replaced, tighten the bolts.
- Replace the special bolts with a bolt, a washer and a nut and tighten the bolts.

Note that the significant section loss in this part of the gusset plate is only observed on the north side of the interior plate of the south trunnion because it is located in the splash zone as shown in Figure 25, and is therefore exposed to de-icing salts used on the west approach roadway. The south trunnion is exposed to more de-icing salts than the north trunnion because of the traffic direction on this side of the bridge; on the north side, westbound traffic has to pass over the open steel deck grating before reaching the main trunnion, and the majority of de-icing salts would have already fallen through the grating.

<sup>4</sup> This staging is similar to the staging performed for the strengthening of the gusset plates of the Honoré-Mercier Bridge (Quebec) in 2011 [7].

At this conceptual stage, considering the current state of deterioration, it is recommended to strengthen the south interior plate by adding a sacrificial plate on the exposed area. Consideration during detailed design should be done to check the influence of future corrosion on the stresses in the gusset plate and validate plate geometry and proposed strengthening against other strengthening Type A1 and Type A2 for constructability purposes.



Figure 25 - Interior plate of the south trunnion located in the splash zone  
 (a) Left: Bridge opened to traffic (b) Right: Bridge during operation

In addition to the strengthening, and to prevent further deterioration due to splashing, it is recommended to use a properly applied four-coat paint system on the exterior side (roadside) of the two interior gusset plates. Moreover, it should be noted that the traffic barrier is interrupted at the trunnion to allow movement between leaf and rear spans as shown in Figure 25 (b). However, this leaves the trunnion, and particularly the pin, vulnerable to an impact with a vehicle, which could damage the pin and have consequences on the bridge serviceability and safety. It is therefore proposed to add a curb on both sides along the entire length of the approach under the bridge. Consideration should be given in detailed design to ensure the design of the current applicable road standards.

## 5.4 Summary of the proposed strengthening

The recommended strengthening, detailed in sections 5.2 and 5.3 for the rehabilitation of the Main Trunnion Assemblies, is summarized in Appendix B for the connecting members and in Appendix C for the gusset plates and fasteners.

Note that some strengthening's aim to repair the same members and areas previously identified in the 2020 Steel Repair Project No. R.097736.002. Coordination between the Main Trunnion Rehabilitation and the 2020 Steel Repairs is required.

# 6 Construction Constraints, Staging and Traffic Management, Staging Areas and Schedule

## 6.1 Construction Timing and Operational Constraints

The following restrictions and operational constraints should be considered during detailed design and construction:

- As the bridge cannot be operational during most of the rehabilitation duration, the work will be done during winter shutdown (December to April) and winter constructions constraints shall be considered including:
  - A heated enclosure for coating operations;
  - As the river does freeze during winter, barge installation will be more difficult; and
  - Construction cost premiums.

- Any construction activities must ensure that no degradation of water quality and aquatic habitat occurs from construction materials, debris, fuels, chemicals, etc. If the proposed work is deemed to meet the definition of a “project” as per the Impact Assessment Act 2019, then a Federal Impact Assessment may be required.
- As it will be discussed in the next section, one vehicular traffic lane with alternating direction must be maintained at all times throughout construction with the exception that full road closures can be considered for short term work (e.g. occasional weekend closures). Accommodation of pedestrians shall also be considered throughout construction.
- The Main Trunnion Rehabilitation project shall take other planned rehabilitation projects for the bridge into consideration with regards to repairs design, construction staging areas, access to/from the work zone, and sequence of work. In particular, the 2020 Steel Repair Project No. R.097736.002 aims to repair some parts of the same members. Consideration should be given to combining this work.

## 6.2 Construction Staging and Traffic Management

---

As the LaSalle Causeway is an important link across the river, the selected construction staging option for the main trunnion rehabilitation of the bascule bridge will have significant impacts on users and adjacent stakeholders.

The LaSalle Causeway separates Kingston's inner and outer harbours, while connecting the east side of the Cataraqui River to downtown Kingston via Highway 2. The Causeway permits intermittent seasonal access to the inner harbour at specific times of day and has a critical role during the peak summer season in facilitating and managing both roadway and river traffic. Therefore, it is intended that the rehabilitation work occurs during the off-peak season, December to April.

There are currently only two major crossings of the Cataraqui River: the LaSalle Causeway in the south, and Highway 401 in the north. A small local road also crosses further north of Highway 401 on Kingston Mills Road/Highway 21.

At this time, the City of Kingston is working to construct a new crossing of the Cataraqui River – the Third Crossing – that is expected to open sometime in the window of 2022-2023. This facility will provide important extra capacity and redundancy in the transportation network across the river, especially for prolonged construction on the crossings.

According to the 2020 Strategic Transportation Analysis report for the main trunnion rehabilitation, four options have been considered to modify the capacity across the LaSalle Causeway to accommodate the rehabilitation work:

- Closure of the eastbound lane – Reducing capacity of the bridge to one lane and allowing only westbound vehicles to cross;
- Closure of the westbound lane – Reducing capacity of the bridge to one lane and allowing only eastbound vehicles to cross;
- Full closure of the bridge – This removes all access across the bridge; and
- Alternating access – Reducing capacity of the bridge to one lane and allowing westbound and eastbound vehicles to cross in an alternating fashion via the existing traffic signals at the bridge or flaggers.

These four options were considered with and without the Third Crossing in place, to provide insight into how it impacts traffic during rehabilitation works. The report recommended that the Alternating Access alternative be pursued with respect to performance of the transportation network in the City of Kingston. It was also recommended that the rehabilitation of the LaSalle Causeway Bascule Bridge occurs after the opening of the Third Crossing.

Therefore, the preferred construction staging option at this time is to have a two-stage construction, maintaining an alternating traffic lane throughout construction, except for short duration full road closures, and regardless of the Third Crossing opening. In Stage 1, proposed rehabilitation works would be performed on one side (north or south) of the bridge allowing traffic on the opposite lane, and inversely for Stage 2.

In determining which side of the bridge should be rehabilitated first, pedestrian accommodation should be taken into consideration, as it is a main constraint throughout construction works. A section of the existing sidewalk on the south side needs to be temporarily removed during the work on the south trunnion and connecting members. As the preferred

approach is to install a temporary sidewalk to accommodate pedestrians (see Section 5.1.2), it was determined that the north trunnion should be rehabilitated first, allowing traffic on the westbound lane and pedestrians on the existing sidewalk. The south trunnion should be rehabilitated in the second stage, with the installation of the temporary sidewalk to accommodate pedestrians and allowing traffic on the eastbound lane.

As discussed in Section 6.4, the construction schedule works in two stages, but there is very little float as the bridge must be reopened on May 1<sup>st</sup>. An alternative staging option would be to position the alternating lane in the middle of the bridge and work simultaneously on both sides. Using a minimum lane width of 3.34 m and concrete barriers on either side to protect the workers, there would be a remaining space of approximately 1.5 m on each side. This would be sufficient to locally demolish the backwall and remove some steel grating to access the main trunnion gusset plates and the members. While the construction cost of this staging option may be higher as the contractor will need to provide accessing equipment (platforms, barges, heated enclosure) simultaneously on both sides, it provides much more room in the schedule for unexpected delays.

Cyclists could travel in the single alternating traffic lane or dismount and walk their bike on the sidewalk provided for pedestrians.

### 6.3 Construction Staging Areas and Access

---

The East and West Wharfs can be used as staging and storage areas. For the access to the underside of the bridge, either a barge moored at the west abutment or a suspended working platform is expected to be used by the contractor. To access member 13-16 and construct an enclosure, scaffolding will most likely be erected. As mentioned in Section 5.1.2, some sections of the curb, the guardrail and the steel grating will be removed to access the gusset plates and the members.

### 6.4 Construction Schedule

---

The construction schedule has been developed for the preferred staging option discussed in Section 6.2 which consists of two stages, one for each side of the bridge. The detailed schedule is presented in Appendix D. It is estimated that the rehabilitation work for each stage roughly takes 2 months to be completed, excluding mobilization and demobilization required for each stage. Considering shutdown period is comprised of 5 months, there is little float for any schedule slippage. It is crucial that the contract is awarded early in September to allow the successful contractor to take field measurements well in advance of the shutdown season and start the preparation of the shop drawings.

The driving factor for the schedule length is not the amount of work, but the fact that multiple strengthening cannot occur at the same time in order to ensure the bridge remains within its capacity during construction. For example, each truss member needs to be strengthened one after the other. The same applies for the strengthening of gusset plates. A significant level of effort will be required at detailed design to ensure the main trunnion gusset plates and the connecting members are not overstressed while some rivets and bolts are temporarily disconnected. If deemed acceptable by the structural analyses carried out at detailed design, some simultaneous strengthening could be authorized to help shorten the duration of each stage. As discussed in Section 6.2, an alternative staging option that would help the construction schedule would be to perform the work in only one stage by positioning the alternating traffic lane in the middle of the bridge. As the detailed design is developed and the exact staging of each strengthening is determined, it will become possible to compare in detail the two construction staging options and decide. The final choice could also be given to the contractor by allowing the two scenarios.



## 7 Construction Cost Estimate

A probable Class 'C' cost estimate to carry out the required strengthening as recommended in this report is estimated at \$2,6 M. The cost estimate is based on 2020 construction prices, excludes HST and includes a 25% contingency allowance. A detailed breakdown of the work items and the cost estimate is provided in Table 2. The cost estimate is based on recent construction costs available from the MTO, and Parsons' own cost database of recently tendered construction projects. The total construction cost is rounded to the nearest \$100,000.

Table 2 - Class 'C' Construction Cost Estimate

Item No.	Item Description	Unit	Qty	Unit Price	Total Cost
1	Traffic Control	LS	1	\$200,000	\$200,000
2	Mobilization/Demobilization	LS	1	\$150,000	\$150,000
3	Access to Work Area	LS	1	\$100,000	\$100,000
4	Environmental Protection (including Winter Heating)	Ea.	2	\$75,000	\$150,000
5	Roadway Protection	LS	1	\$50,000	\$50,000
6	Localized Removal and Reinstatement of Sidewalk and Pedestrian Railing	LS	1	\$10,000	\$10,000
7	Temporary Sidewalk	LS	1	\$50,000	\$50,000
8	Localized Removal and Reinstatement of Steel Deck Grating, Timber Curbs, and Traffic Railing	LS	1	\$40,000	\$40,000
9	Demolition and Reconstruction of Ends of West Abutment	Ea.	2	\$15,000	\$30,000
10	Strengthening Member 13-16	Ea.	2	\$140,000	\$280,000
11	Strengthening Member 14-16	Ea.	2	\$100,000	\$200,000
12	Strengthening Member 14-15	Ea.	2	\$60,000	\$120,000
13	Strengthening Member 15-17	Ea.	2	\$90,000	\$180,000
14	Strengthening Main Trunnion Gusset Plate - Type A1	Ea.	4	\$30,000	\$120,000
15	Strengthening Main Trunnion Gusset Plate - Type B	Ea.	4	\$5,000	\$20,000
16	Strengthening Main Trunnion Gusset Plate - Type C	Ea.	4	\$15,000	\$60,000
17	Strengthening Main Trunnion Gusset Plate - Type D	Ea.	2	\$30,000	\$60,000
18	Strengthening Main Trunnion Gusset Plate - Type E	Ea.	1	\$10,000	\$10,000
19	Strengthening Main Trunnion Gusset Plate - Type F	Ea.	1	\$40,000	\$40,000
20	Structural Steel Coating Repairs	LS	1	\$150,000	\$150,000
21	Bridge Balancing	LS	1	\$50,000	\$50,000
				<b>Sub-Total</b>	<b>\$2,070,000</b>
				Contingency (25%)	\$517,500
				<b>TOTAL CONSTRUCTION COST (ROUNDED TO THE NEAREST \$100,000)</b>	<b>\$2,600,000</b>



## 8 Closure

We trust that this report contains enough information for your present purposes. If you have any questions regarding this report, please do not hesitate to contact us.

Yours truly,  
PARSONS INC.

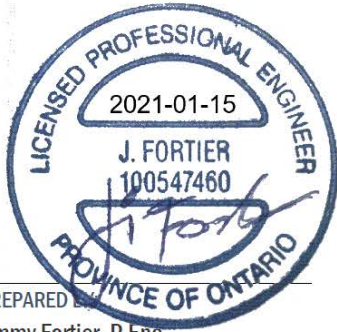

PREPARED BY:  
Jimmy Fortier, P.Eng.  
Structural Engineer

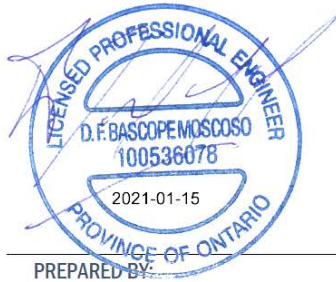

PREPARED BY:  
Dennis Bascope, P.Eng.  
Structural Engineer



PREPARED BY:  
Kevin Serre, ing.  
Structural Engineer

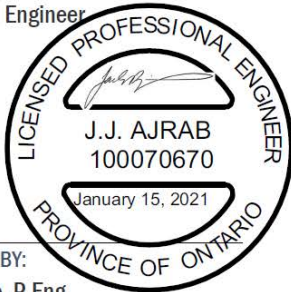

REVIEWED BY:  
Jack Ajrab, P.Eng.  
Structural Engineer



REVIEWED BY:  
Peter Harvey, P.Eng.  
Structural Engineer

## References

- [1] CAN/CSA S6-19 Canadian Highway Bridge Design Code (CHBDC), Canadian Standards Association (CSA), 2019
- [2] LaSalle Causeway Bascule Bridge Main Trunnion Rehabilitation Study- Detailed Inspection Memorandum (Revision 1), PSPC Project Number: R.099350.002, 2020
- [3] LaSalle Causeway Bascule Bridge Main Trunnion Rehabilitation Study- Structural Evaluation Report, PSPC Project Number: R.099350.002, 2020.
- [4] LaSalle Causeway Bridge Engineering Services - Draft Technical Memorandum, PWGSC Project No. R.0977036.002 – Structural Steel Repairs, January 6, 2020.
- [5] LaSalle Causeway Bridge – Asbestos and Lead Reassessment Survey, AET Group Inc., Project No. PUB\_EC1718\_040, March 27, 2018.
- [6] LaSalle Causeway Bridge – 2018 Fatigue Inspection and Evaluation Report, Parsons, March 1<sup>st</sup>, 2019.
- [7] Bessette et Fay, Renforcement des goussets du pont Honoré-Mercier, 19<sup>e</sup> colloque sur la progression de la recherche québécoise sur les ouvrages d’art, 2012.
- [8] LaSalle Causeway Bascule Bridge Main Trunnion Rehabilitation – Strategic Transportation Analysis, PSPC Project Number: R.099350.002, 2020.

## Appendix A – Wiss, Janney, Elstner Associates' Recommendations



January 7, 2021

Peter Harvey  
Project Manager  
Parsons Corporation  
1223 Michael Street North  
Suite 100  
Ottawa Ontario, K1J 7T2

## **LaSalle Causeway Bridge Heel Trunnion Rehabilitation**

WJE No. OSBE.0790.H

Dear Mr. Harvey

As part of the LaSalle Causeway Bridge main trunnion bearings rehabilitation project, the existing trunnion bearings were evaluated based on available criteria and the machinery loads were evaluated as the basis for structural repairs.

Calculations were prepared to determine the existing heel trunnion reactions, effective bearing area and resultant bearing pressures when at rest and in motion. The existing heel trunnion bearing pressures are 2,292 psi in motion and 2,737 psi at rest.

The current edition of the CAN/CSA S6-19 Canadian Highway Bridge and Design Code (CHBDC) specifies various alloys for bronze plain bearings, all of which fall under ASTM B22. Per CHBDC Table 13.7 "Maximum bearing pressures," the specified material to be used for trunnion bearings of bascule bridges is ASTM B22 Alloy 911. This is a "high tin bronze." The allowable pressure for ASTM B22 alloy 911 when bearing on a rolled or forged steel trunnion is 1,500 psi in motion and 2,000 psi at rest. The existing main trunnion bearings exceed these pressures by 53% and 37%, respectively. As such, if the trunnions and bushings were to be replaced with a new design, using the materials and maximum bearing pressures specified in the in the CHBDC, the size of the shaft and bearing would need to be increased.

The existing main trunnion bearings date back to the original installation. The original drawings note the bearing bushing material to be "phosphor bronze". At the time of manufacture, circa 1916 there were numerous proprietary phosphor bronze alloys as well as different classes and it is not possible to know the physical properties without removal and lab testing. From a design standpoint we do not have an explicit "maximum bearing pressure" for this bronze material defined within the CHBDC.

The primary function of bearings is to support their matching shaft, both in a fixed position and throughout operation, and to provide a smooth, low friction interface. These are wearing components. Due to the arrangement of the structure and bearings, the bushings are inaccessible for direct measurement and evaluation of wear. As such, the most appropriate means of evaluating the condition of the bearing is based on their physical performance. For example, do the bearings exhibit unusual noise, heat or vibration during operation, and is there excessive friction. We have performed testing at this structure on several occasions where strain gages were used to monitor operating loads and total system

friction was calculated. The results of this testing indicate that total system friction for this bridge is very low. Additionally, we have not noted any unusual noise, heat, or vibration. On the basis of this information we can conclude that there is no evidence to suggest that replacement of these bearings is warranted and the main trunnion bearings may remain in service as-is without modification. While the existing bearings appear to have performed well under the current loading, it is not recommended increase the bearing loads beyond the current levels due to the uncertainty about how this bearing material will respond.

In order to evaluate the existing structure and to design the necessary structural repairs the loads at the operating struts must be considered. It should be noted that as part of the motor and drive replacement project circa 2018, the capacity of the original motors was evaluated against the CSA/S6-14 design criteria and it was found that they were overloaded. Further analysis indicated that the motor capacity could not be increased without replacement of the other machinery components. As such, the new motors were sized to accommodate the existing machinery and do not meet the requirements of the CHBDC regarding wind loading during operation. Restrictions have been imposed to limit operation to periods when the wind pressure is equal or less than 0.24 kPa (equivalent to a speed of 69 km/hr). The letter documenting this deviation is attached for reference. The forces applied to the operating struts are limited to the loads which can be developed by the motors and the brakes. If there are external loads that are greater than the maximum capacity of the motors or brakes, the machinery will pull through them and result in movement of the span. This means that the operating strut loads are effectively limited.

Per CHBDC 13.7.3.1.a, *"machinery driven by electric motors shall be designed for 150% of the rated full-load torque of the motor or motors at normal unit stresses."* This corresponds to an unfactored load of 256 kN in each operating strut.

It is our recommendation that an impact of 100% of the  $M_0$  force be considered as specified by the CHBDC. For special load combinations with wind loads (ULS B2 and B3) a reduced design wind pressure should be used which would deviate from the CHBDC and AASHTO LRFD Movable Highway Bridge Design Specifications.

Sincerely,

**WISS, JANNEY, ELSTNER ASSOCIATES, INC.**



Michael P. Broglie  
Associate III



John Williams, P. Eng.  
Associate Principal





**STAFFORD BANDLOW ENGINEERING, INC.**

---

July 24, 2017

**Via E-Mail**

[Maurice.Mansfield@parsons.com](mailto:Maurice.Mansfield@parsons.com)

Mr. Maurice Mansfield  
Parsons  
1223 Michael St., Suite 100  
Ottawa, ON K1J 7T2

Maurice,

As part of the LaSalle Causeway Bridge motor and drive rehabilitation design, the existing machinery and prime mover were evaluated with regard to the 2014 edition of the CAN/CSA S6 Canadian Highway Bridge and Design Code (CHBDC), Section 13 requirements. It was determined that the current prime mover, which consists of two 50 HP at 585 RPM motors operating together, were overloaded by a factor of 1.50.

The existing gears, shafts, keys, and bearings were evaluated with regard to the current prime mover using the information provided by the original and 1966 rehab drawings. There was sufficient legible to evaluate the capacity of the gears, shafts and bearings. It was determined that these existing machinery components are appropriately sized for the existing prime mover. However, there is little reserve capacity in the existing gears and therefore increasing the capacity of the prime mover as part of the motor and drive replacement project is not possible unless the scope of the replacement work is increased to include virtually all of the existing gearing.

It should be noted that there is limited legible information on the key sizes and lengths on the available drawings. As such any evaluation of the existing keys is considered preliminary until such time that the existing key dimensions can be verified at the bridge.

Although the existing prime mover is overloaded per Code requirements, the bridge is routinely operated on a single motor and there are no reported issues of the existing motors (individually or operating as a pair) failing to operate the bascule leaf in the recent past or over its' history of operating since circa 1915. As such, it would appear to be reasonable to maintain the current capacity of the motors with the replacement motors which would provide for reliable operation without exceeding the capacity of the existing machinery.

The loads on the prime mover during operation of a bascule leaf are caused by imbalance, friction, inertia, wind and ice as follows per Article 13.7.14.7.2 of the CHBDC:

- (a) Maximum starting torque ( $T_s$ ) shall be determined for span operation against static frictional resistance, unbalanced conditions (if any), a wind load of 0.48 kPa (10 psf) on any vertical projection, and an ice loading of 0.12 kPa (2.5 psf) on the area specified in Clause 13.6.4.5 and shall include inertial resistance due to acceleration.

- (b) Maximum constant velocity torque ( $T_{cv}$ ) shall be determined for span operation against dynamic frictional resistances, unbalanced conditions (if any), and a wind load of 0.12 kPa (2.5 psf) acting normal to the floor on the area specified in Clause 13.6.4.5.

Maximum starting torque is the limiting case for sizing the prime mover. Imbalance, friction, inertia are not practical to modify. As such, limitations on wind pressure (and therefore maximum wind speeds) must be modified if the prime mover does not have adequate capacity to fully comply with CHBDC requirements. The existing (and proposed new) prime mover has sufficient capacity to operate the span with a wind pressure of 0.24 kPa (5 psf).

Wind loads for movable bridge operation are given in the Code as a wind pressure. The commentary on Annex CA3.1 – Climate and environmental data in CAN/CSA S6-14 provides a formula describing the relationship between the reference pressure,  $q$  (in Pa), and the corresponding mean hourly wind speed,  $v$  (in km/h):

$$q = 0.05 v^2$$

Using this formula, the wind speed corresponding to the Code required design wind pressure (480 Pa) is 98 km/hr and the wind speed corresponding to the proposed maximum permissible wind pressure (240 Pa) is 69 km/hr.

In order to implement the wind speed restrictions for the bascule leaf operation it would be necessary to revise operating procedures to check wind speeds. This may be done using dedicated wind speed monitoring equipment installed at the bridge (which does not presently exist), or by checking wind speeds at a nearby weather station via the internet.

Please advise if it is acceptable to deviate from CAN/CSA S6-14 Canadian Highway Bridge and Design Code requirements and design the new motors and drives with the same capacity as the existing prime movers at the bridge which will require implementation of operating restrictions to periods when the wind speeds are less than 69 km/hr and adopting new operating procedures for verifying acceptable wind speeds.

If you have any questions or would like to discuss any of the above in further detail, please do not hesitate to contact me at (215) 340-5830.

Sincerely,

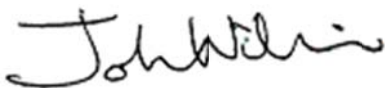

John Williams, P.Eng.

## Appendix B – Location of the Proposed Strengthening for the Connecting Members of the Main Trunnion Assemblies

# Location of Proposed Strengthening elements for Connecting Members

Strengthening elements are in blue if installed outside and in red if installed inside of the member

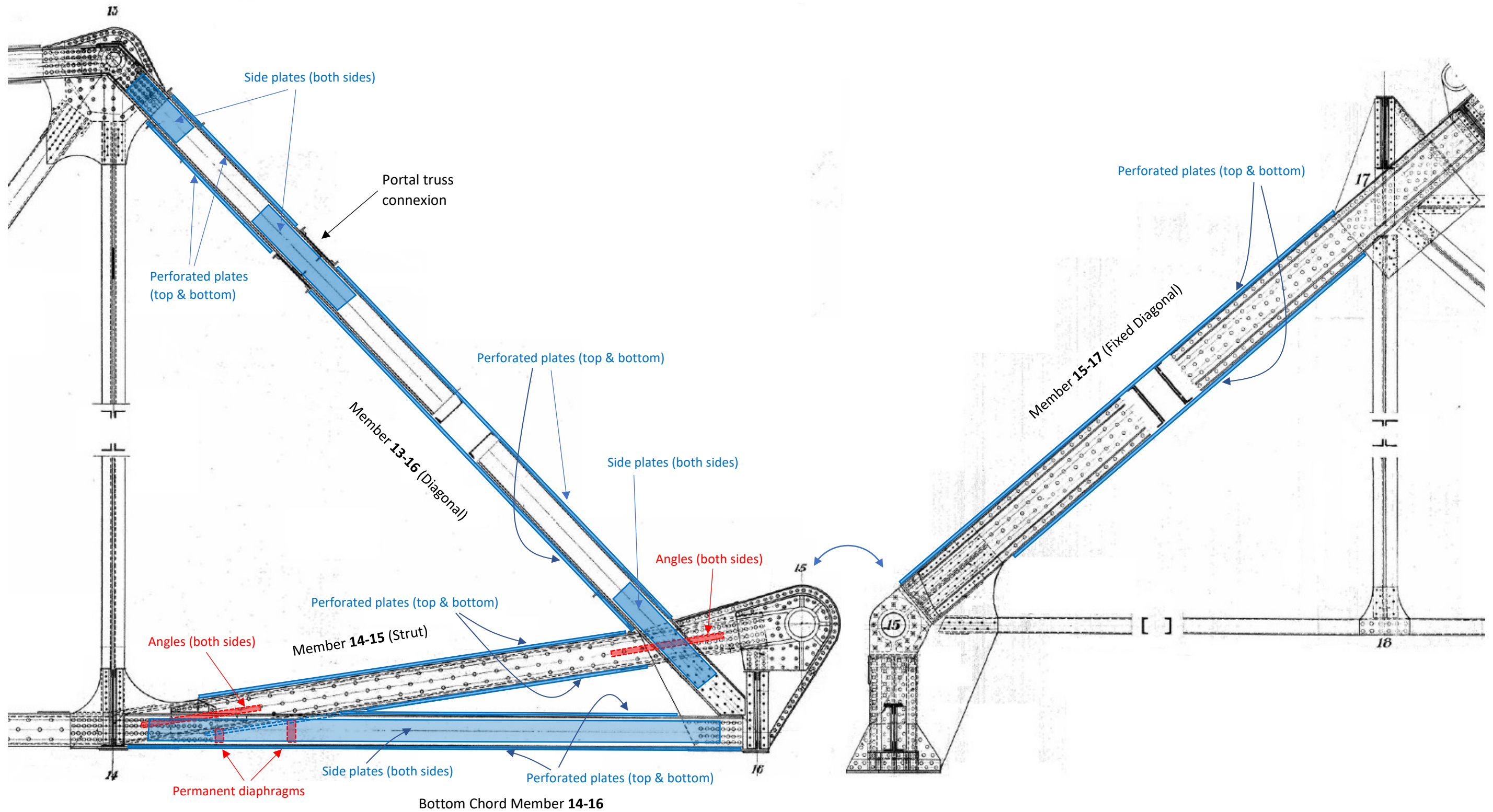

## Appendix C – Location of the Proposed Strengthening for the Gusset Plates of the Main Trunnion Assemblies



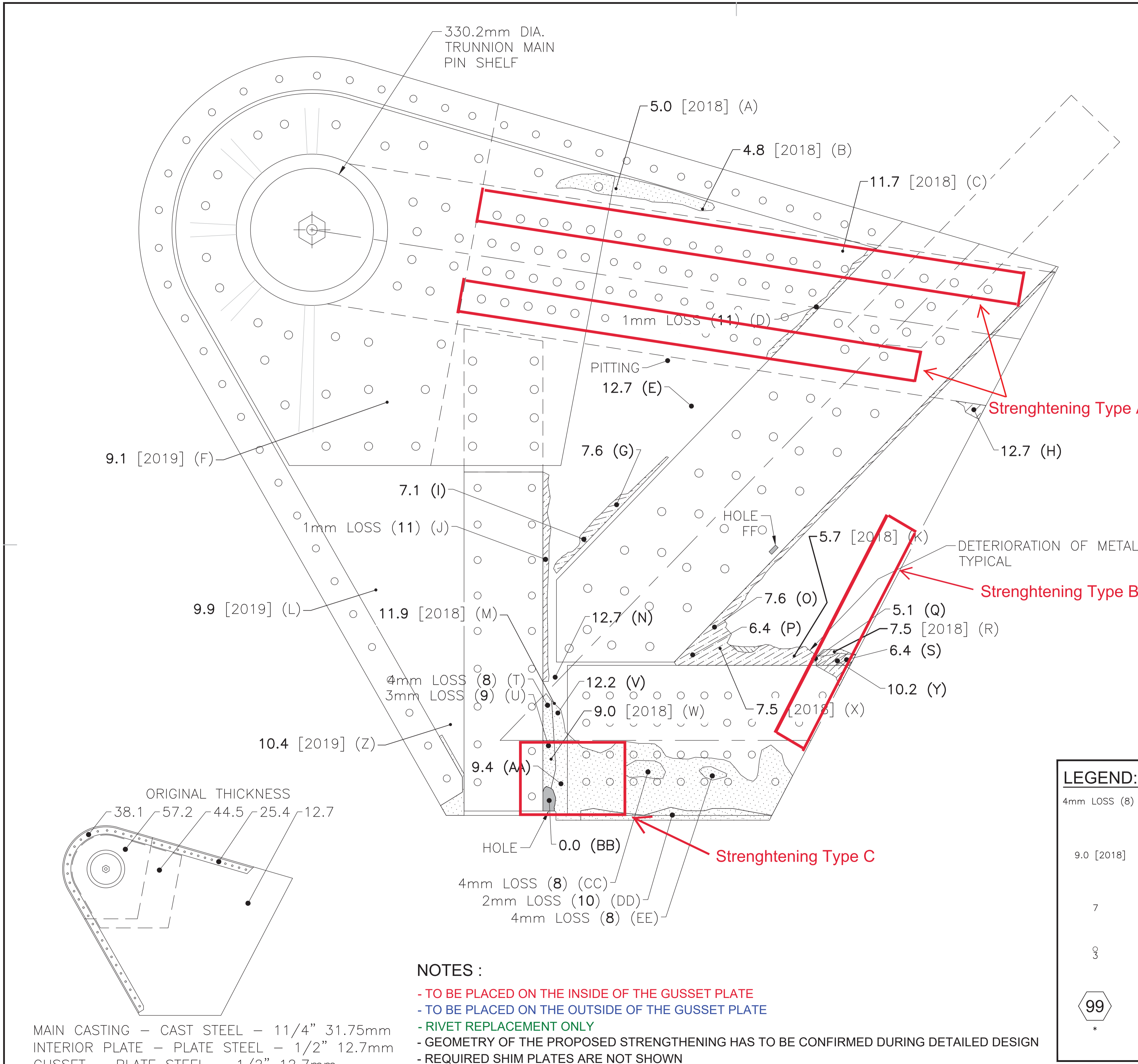

SOUTH TRUNNION EXTERIOR PLATE			
READING	ORIGINAL THICKNESS (mm)	REMAINING THICKNESS (mm)	PERCENT LOSS (%)
A	12.7	5	60.6
B	12.7	4.8	62.2
C	12.7	11.7	7.9
D	12.7	11	13.4
E	12.7	12.7	0.0
F	12.7	9.1	28.3
G	12.7	7.6	40.2
H	12.7	12.7	0.0
I	12.7	7.1	44.1
J	12.7	11	13.4
K	12.7	5.7	55.1
L	12.7	9.9	22.0
M	12.7	11.9	6.3
N	12.7	12.7	0.0
O	12.7	7.6	40.2
P	12.7	6.4	49.6
Q	12.7	5.1	59.8
R	12.7	7.5	40.9
S	12.7	6.4	49.6
T	12.7	8	37.0
U	12.7	9	29.1
V	12.7	12.2	3.9
W	12.7	9	29.1
X	12.7	7.5	40.9
Y	12.7	10.2	19.7
Z	12.7	10.4	18.1
AA	12.7	9.4	26.0
BB	12.7	0	100.0
CC	12.7	8	37.0
DD	12.7	10	21.3
EE	12.7	8	37.0
FF	12.7	0	100.0

**Canada**

THIS DRAWING IS AN UPDATED VERSION OF THE 2015 DRAWINGS FROM THE REPORT "TRUNNION JOINT INSPECTION AND ANALYSIS" BY MMM GROUP LIMITED. PARSONS RESPONSIBILITY IS LIMITED TO NEW [2018] INFORMATION ADDED ON THE DRAWING.

**PARSONS**

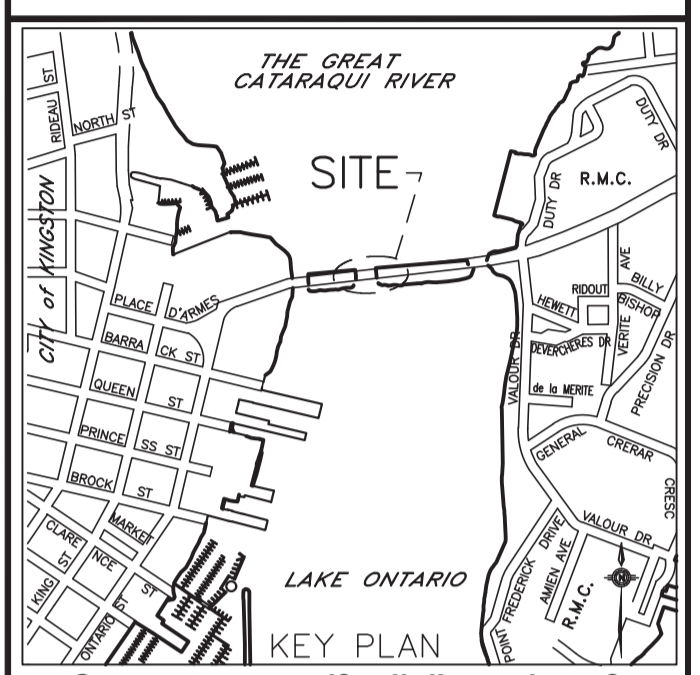

**Contractor to verify all dimensions & conditions on site and immediately notify the engineer of all discrepancies.**

**dimensions et conditions sur le site et toute divergence.**

revisions	description	date

A	B	C
A detail no. / no. du détail	A	A
B location drawing no. / sur dessin no.	B	B
C drawing no. / dessin no.	C	C

project / projet

**LASALLE CAUSEWAY TRUNNION EVALUATION**

drawing / dessin

**SOUTH TRUNNION FULL EXTERIOR PLATE DETERIORATION A B**

Designed By	.....
Date	(yyyy/mm/dd)
Drawn By	.....
Date	22 JAN 2020 (yyyy/mm/dd)
Reviewed By	.....
Date	22 JAN 2020 (yyyy/mm/dd)
Approved By	.....
Date	(yyyy/mm/dd)
Tender	Soumission
Project Manager	Administrateur de projets
Project no.	No. du projet
<b>R.099350.002</b>	
Drawing no.	No. du dessin
<b>0000-1</b>	

**LEGEND:**

4mm LOSS (8) PLATE SECTION LOSS (REMAINING THICKNESS IN MILLIMETRES BASED ON 12mm THICKNESS)

9.0 [2018] REMAINING THICKNESS IN MILLIMETRES BASED ON ULTRASONIC MEASUREMENTS [YEAR MEASUREMENT TAKEN]

7 REMAINING THICKNESS IN MILLIMETRES. BASED ON ULTRASONIC MEASUREMENTS

3 DETERIORATED RIVETS PERCENT SECTION REMAINING DIVIDED BY 10 (i.e. 1=10%, 2=20%, 3=30%, ETC.)

99 PHOTOGRAPH KEY

\* PHOTO FROM 2015 MMM GROUP LIMITED REPORT

- NOTES :**
- TO BE PLACED ON THE INSIDE OF THE GUSSET PLATE
  - TO BE PLACED ON THE OUTSIDE OF THE GUSSET PLATE
  - RIVET REPLACEMENT ONLY
  - GEOMETRY OF THE PROPOSED STRENGTHENING HAS TO BE CONFIRMED DURING DETAILED DESIGN
  - REQUIRED SHIM PLATES ARE NOT SHOWN

MAIN CASTING – CAST STEEL – 11/4” 31.75mm  
 INTERIOR PLATE – PLATE STEEL – 1/2” 12.7mm  
 GUSSET – PLATE STEEL – 1/2” 12.7mm



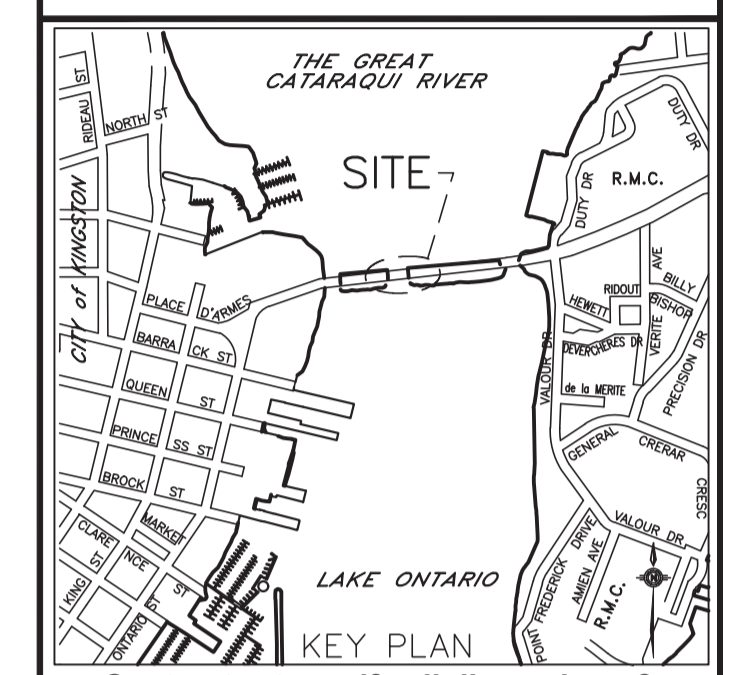

Contractor to verify all dimensions & conditions on site and immediately notify the engineer of all discrepancies.  
 dimensions et conditions sur le site et toute divergence.

SOUTH TRUNNION INTERIOR PLATE			
READING	ORIGINAL THICKNESS (mm)	REMAINING THICKNESS (mm)	PERCENT LOSS (%)
A	12.7	3.3	74.0
B	12.7	6.6	48.0
C	12.7	7.6	40.2
D	12.7	9.6	24.4
E	12.7	8.3	34.6
F	12.7	8.2	35.4
G	12.7	6.1	52.0
H	12.7	6.9	45.7
I	12.7	6.4	49.6
J	12.7	6.0	52.8
K	23.8	17.5	26.5
L	12.7	5.0	60.6
M	12.7	3.0	76.4
N	12.7	7.4	41.7
O	12.7	6.7	47.2
P	12.7	6.4	49.6
Q	12.7	10.7	15.7
R	12.7	5.7	55.1
S	23.8	18.8	21.0
T	12.7	12.7	0.0
U	12.7	5.7	55.1
V	12.7	9.7	23.6
W	12.7	12.7	0.0
X	12.7	11.6	8.7
Y	12.7	9.0	29.1
Z	12.7	10.0	21.3
AA	12.7	12.7	0.0
BB	12.7	10.0	21.3
CC	12.7	11.0	13.4

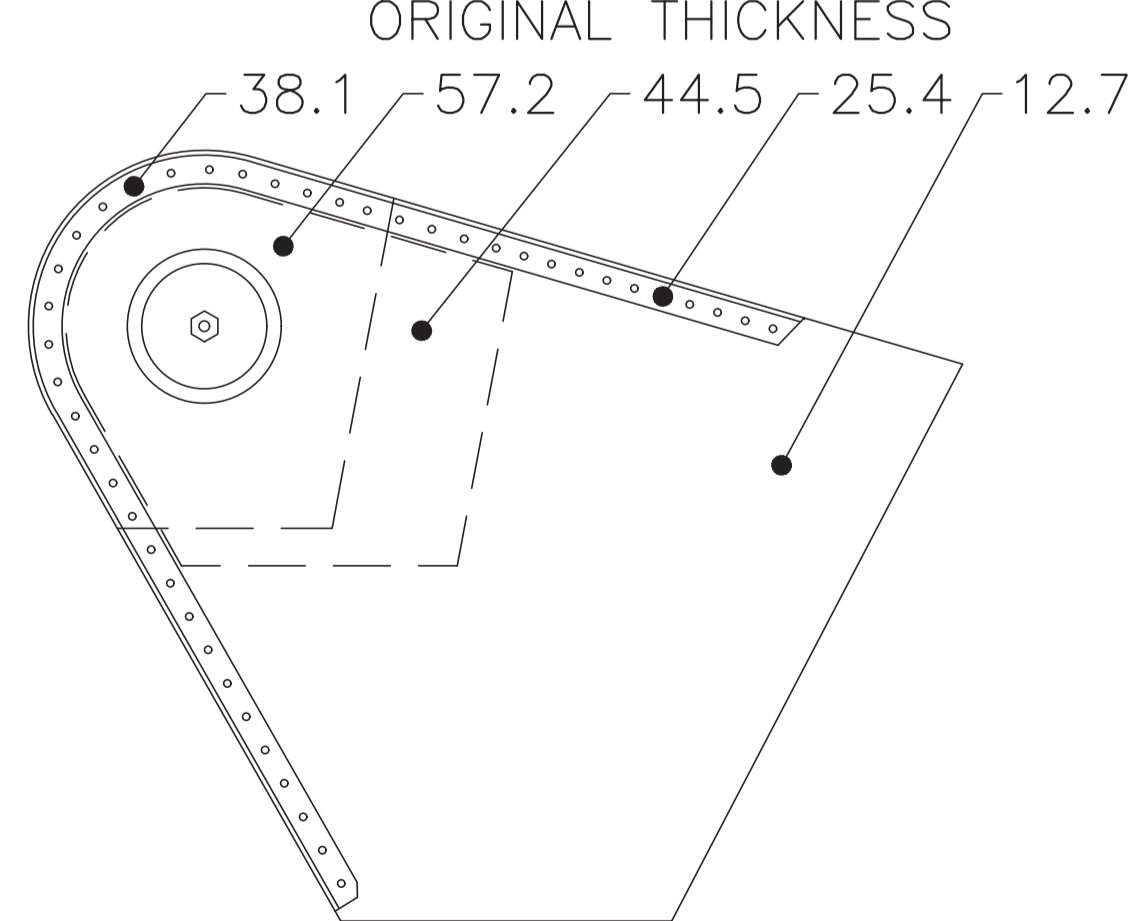
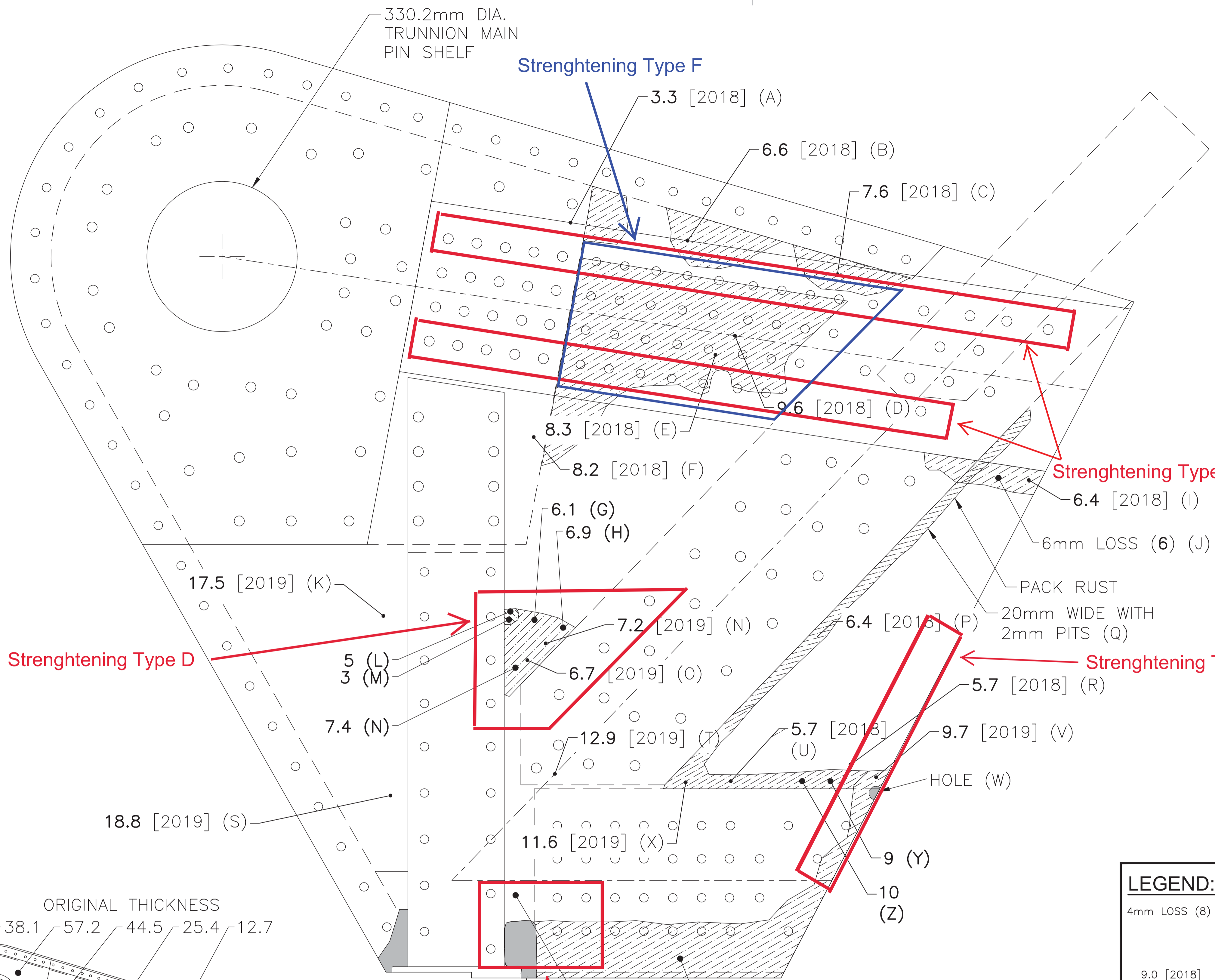

MAIN CASTING – CAST STEEL – 11/4" 31.75mm  
 INTERIOR PLATE – PLATE STEEL – 1/2" 12.7mm  
 GUSSET – PLATE STEEL – 1/2" 12.7mm

- NOTES :**
- TO BE PLACED ON THE INSIDE OF THE GUSSET PLATE
  - TO BE PLACED ON THE OUTSIDE OF THE GUSSET PLATE
  - RIVET REPLACEMENT ONLY
  - GEOMETRY OF THE PROPOSED STRENGTHENING HAS TO BE CONFIRMED DURING DETAILED DESIGN
  - REQUIRED SHIM PLATES ARE NOT SHOWN

**LEGEND:**

- 4mm LOSS (8) PLATE SECTION LOSS (REMAINING THICKNESS IN MILLIMETRES BASED ON 12mm THICKNESS)
- 9.0 [2018] REMAINING THICKNESS IN MILLIMETRES BASED ON ULTRASONIC MEASUREMENTS [YEAR MEASUREMENT TAKEN]
- 7 REMAINING THICKNESS IN MILLIMETRES. BASED ON ULTRASONIC MEASUREMENTS
- 3 DETERIORATED RIVETS PERCENT SECTION REMAINING DIVIDED BY 10 (i.e. 1=10%, 2=20%, 3=30%, ETC.)
- 99 PHOTOGRAPH KEY
- \* PHOTO FROM 2015 MMM GROUP LIMITED REPORT

revisions	description	date

project		dessin	
LASALLE CAUSEWAY TRUNNION EVALUATION			
SOUTH TRUNNION FULL INTERIOR PLATE DETERIORATION C D			
Designed By	.....		
Date	(yyyy/mm/dd)		
Drawn By	.....		
Date	R.D.	22 JAN 2020 (yyyy/mm/dd)	
Reviewed By	.....		
Date	B.R.M.	22 JAN 2020 (yyyy/mm/dd)	
Approved By	.....		
Date	(yyyy/mm/dd)		
Tender	Soumission		
Project Manager	Administrateur de projets		
Project no.	No. du projet		
R.099350.002			
Drawing no.	No. du dessin		
0000-2			









THIS DRAWING IS AN UPDATED VERSION OF THE 2015 DRAWINGS FROM THE REPORT "TRUNNION JOINT INSPECTION AND ANALYSIS" BY MMM GROUP LIMITED. PARSONS RESPONSIBILITY IS LIMITED TO NEW [2018] INFORMATION ADDED ON THE DRAWING.

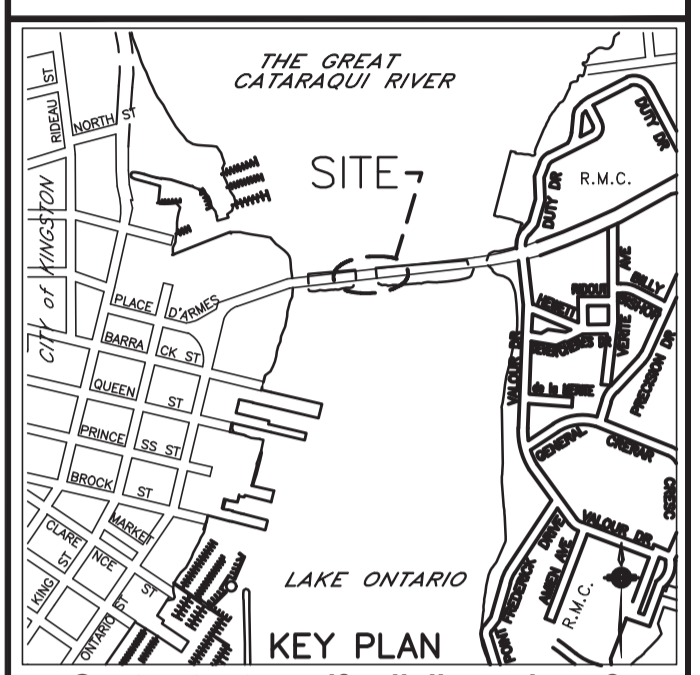

Contractor to verify all dimensions & conditions on site and immediately notify the engineer of all discrepancies.  
 dimensions et conditions sur le site et toute divergence.

NORTH TRUNNION EXTERIOR PLATE			
READING	ORIGINAL THICKNESS (mm)	REMAINING THICKNESS (mm)	PERCENT LOSS (%)
A	12.7	9.0	29.1
B	12.7	8.0	37.0
C	12.7	9.0	29.1
D	12.7	12.7	0.0
E	12.7	11.0	13.4
F	12.7	9.3	26.8
G	12.7	12.7	0.0
H	12.7	12.7	0.0
I	12.7	11.8	7.1
J	12.7	8.0	37.0
K	12.7	10.9	14.2
L	12.7	12.7	0.0
M	12.7	9.9	22.0
N	12.7	8.4	33.9
O	12.7	12.7	0.0
P	12.7	8.6	32.3
Q	12.7	9.4	26.0
R	12.7	12.5	1.6
S	12.7	10.5	17.3
T	12.7	9.0	29.1
U	12.7	8.0	37.0
V	12.7	7.0	44.9
W	12.7	9.0	29.1
X	12.7	10.5	17.3
Y	12.7	8.0	37.0
Z	12.7	11.1	12.6
AA	12.7	9.0	29.1
BB	12.7	12.7	0.0
CC	12.7	11.2	11.8
DD	12.7	11.0	13.4
EE	12.7	8.0	37.0
FF	12.7	12.7	0.0
GG	12.7	4.0	68.5
HH	12.7	5.0	60.6
II	12.7	8.0	37.0
JJ	12.7	4.0	68.5

revisions	description	date

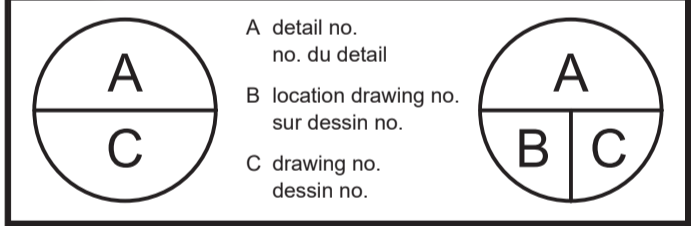

project LASALLE CAUSEWAY TRUNNION EVALUATION

drawing NORTH TRUNNION FULL EXTERIOR PLATE DETERIORATION G H

Designed By: \_\_\_\_\_ Date: (yyyy/mm/dd)

Drawn By: R.D. Date: 22 JAN 2020 (yyyy/mm/dd)

Reviewed By: B.R.M. Date: 22 JAN 2020 (yyyy/mm/dd)

Approved By: \_\_\_\_\_ Date: (yyyy/mm/dd)

Tender: Soumission

Project Manager: Administrateur de projets

Project no. R.099350.002

Drawing no. 0000-4

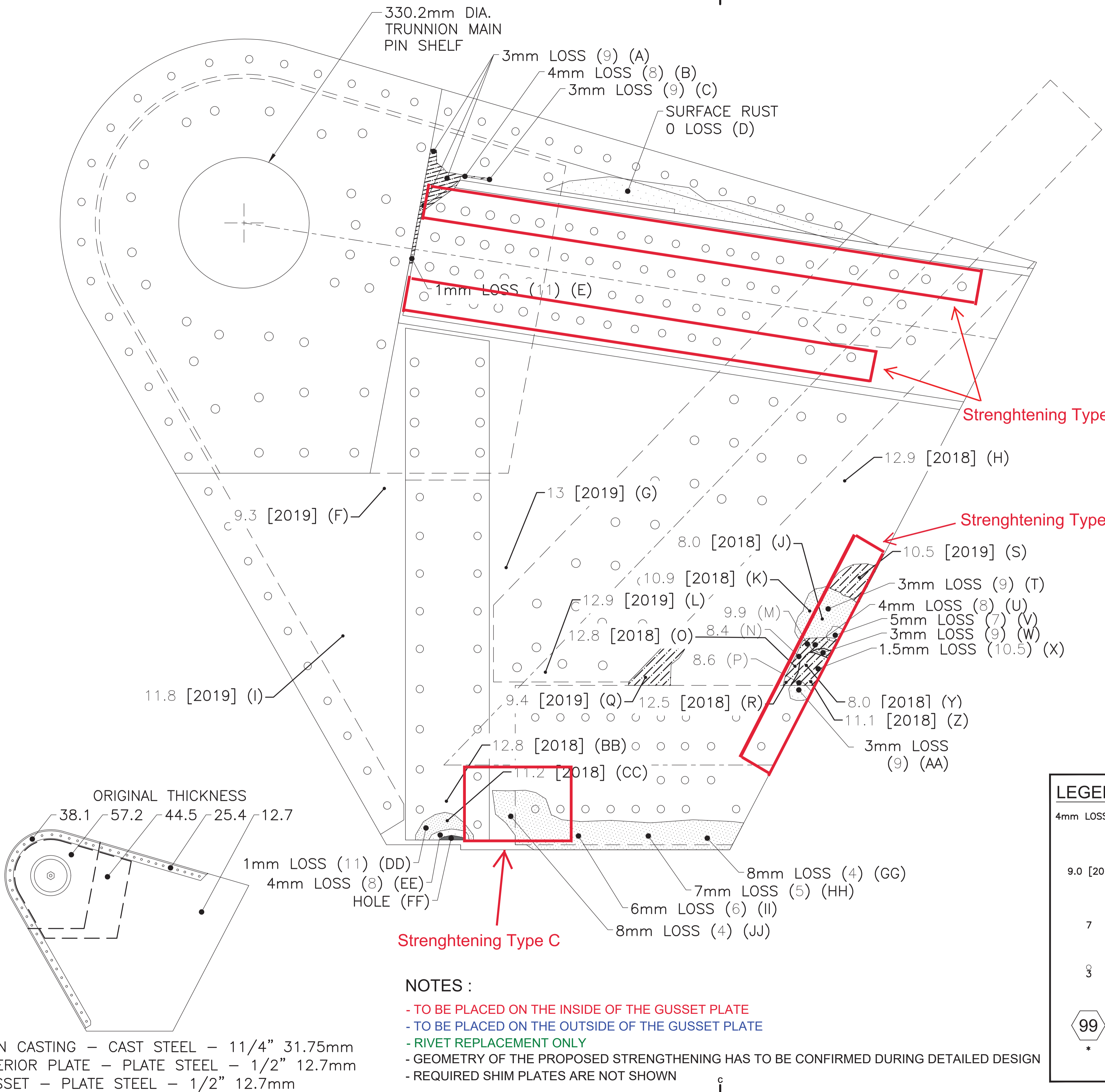

**NOTES :**

- TO BE PLACED ON THE INSIDE OF THE GUSSET PLATE
- TO BE PLACED ON THE OUTSIDE OF THE GUSSET PLATE
- RIVET REPLACEMENT ONLY
- GEOMETRY OF THE PROPOSED STRENGTHENING HAS TO BE CONFIRMED DURING DETAILED DESIGN
- REQUIRED SHIM PLATES ARE NOT SHOWN

**LEGEND:**

4mm LOSS (8) PLATE SECTION LOSS (REMAINING THICKNESS IN MILLIMETRES BASED ON 12mm THICKNESS)

9.0 [2018] REMAINING THICKNESS IN MILLIMETRES BASED ON ULTRASONIC MEASUREMENTS [YEAR MEASUREMENT TAKEN]

7 REMAINING THICKNESS IN MILLIMETRES. BASED ON ULTRASONIC MEASUREMENTS

3 DETERIORATED RIVETS PERCENT SECTION REMAINING DIVIDED BY 10 (i.e. 1=10%, 2=20%, 3=30%, ETC.)

99 PHOTOGRAPH KEY

\* PHOTO FROM 2015 MMM GROUP LIMITED REPORT



## Appendix D – Construction Schedule





# Lasalle Causeway Bascule Bridge Main Trunnion Rehabilitation Study – Design Concept Report

---

**Jimmy Fortier, P.Eng.**

1800 McGill College Avenue,  
Suite 510  
Montréal, QC H3A 3J6  
514.375.4949

**Dennis Bascopé, P.Eng.**

1800 McGill College Avenue,  
Suite 510  
Montréal, QC H3A 3J6  
514.375.4949

**Kevin Serre, ing.**

1800 McGill College Avenue,  
Suite 510  
Montréal, QC H3A 3J6  
514.375.4949

**Jack Ajrab, P.Eng.**

1223 Michael Street North,  
Suite 100  
Ottawa, ON K1N 7X4  
613.738-4160

**Peter Harvey, P.Eng.**

1223 Michael Street North,  
Suite 100  
Ottawa, ON K1N 7X4  
613.738-4160



5875 Trinity Parkway, Suite 300  
Centreville, Virginia 20120  
Direct: +1 703.988.8500  
parsons.com

© Copyright 2020 Parsons Corporation.  
All Rights Reserved.