



National Defence

National Defence Headquarters
Ottawa, Ontario
K1A 0K2

Défense nationale

Quartier général de la Défense nationale
Ottawa (Ontario)
K1A 0K2

REQUEST FOR PROPOSAL DEMANDE DE PROPOSITION

**AMENDMENT NO.
N° DE LA MODIFICATION**
003

**RETURN BIDS TO:
RETOURNER LES SOUMISSIONS À :**

Adam Lee, DLP 3-2-5-1
adam.lee@forces.gc.ca

Proposal To: National Defence Canada

We hereby offer to sell to Her Majesty the Queen in right of Canada, in accordance with the terms and conditions set out herein, referred to herein or attached hereto, the goods and services listed herein and on any attached sheets at the price(s) set out therefore.

Proposition à : Défense nationale Canada

Nous offrons par la présente de vendre à Sa Majesté la Reine du chef du Canada, aux conditions énoncées ou incluses par référence dans la présente et aux annexes ci-jointes, les biens et services énumérés ici et sur toute feuille ci-annexée, au(x) prix indiqué(s).

**Solicitation Closes –
L'invitation prend fin**

At: – à :
14h00 EDT-HAE

On: – le :
21 September 2021 / 21 Septembre 2021

| | |
|--|---|
| Title/Titre Gas Mask Carrier | Solicitation No – N° de l'invitation W8486-217451/A |
| Date of Solicitation – Date de l'invitation 02 September 2021 / 02 Septembre 2021 | |
| Address Enquiries to – Adresser toutes questions à Adam Lee Adam.Lee@forces.gc.ca | |
| Telephone No. – N° de téléphone 819-939-3250 | FAX No – N° de fax |
| Destination See Herein | |

Instructions: Municipal taxes are not applicable. Unless otherwise specified herein all prices quoted must include all applicable Canadian customs duties, GST/HST, excise taxes and are to be delivered Delivery Duty Paid including all delivery charges to destination(s) as indicated. The amount of the Goods and Services Tax/Harmonized Sales Tax is to be shown as a separate item.

Instructions : Les taxes municipales ne s'appliquent pas. Sauf indication contraire, les prix indiqués doivent comprendre les droits de douane canadiens, la TPS/TVH et la taxe d'accise. Les biens doivent être livrés « rendu droits acquittés », tous frais de livraison compris, à la ou aux destinations indiquées. Le montant de la taxe sur les produits et services/taxe de vente harmonisée doit être indiqué séparément.

| |
|--|
| Delivery Required – Livraison exigée |
| Vendor Name and Address – Raison sociale et adresse du fournisseur |
| Name and title of person authorized to sign on behalf of vendor (type or print) – Nom et titre de la personne autorisée à signer au nom du fournisseur (caractère d'imprimerie) |
| Name – Nom _____ Title – Titre _____ |
| Signature _____ Date _____ |

Amendment 003 is raised to address the following:

NOTE (4) – English: Change to the Solicitation Closes –
L’invitation prend fin

Delete :

At: – à :
14h00 EDT

On: – le :
07 September 2021

Insert :

At: – à :
14h00 EDT

On: – le :
21 September 2021

REMARQUE (4) – French : Changement L’invitation prend fin

Supprimer:

At: – à :
14h00 EDT

On: – le :
07 Septembre 2021

Insérer:

At: – à :
14h00 EDT

On: – le :
21 Septembre 2021

NOTE (3) - English: Correction to section 2.6 Availability of Drawings

Delete:

In order to receive a TDP, the proposed Bidder must return a signed copy of **Annex E** to the Contracting Authority on page 1 of this Request for Proposal.

Insert:

In order to receive a TDP, the proposed Bidder must return a signed copy of **Annex F** to the Contracting Authority on page 1 of this Request for Proposal.

REMARQUE (3) - French: Correction à section 2.6 Disponibilité des dessins

Supprimer:

Afin de recevoir un dossier de données techniques, le soumissionnaire proposé doit envoyer une copie signée de l’**annexe E** à l’autorité contractante figurant à la page 1 de la présente demande de propositions.

Insérer:

Afin de recevoir un dossier de données techniques, le soumissionnaire proposé doit envoyer une copie signée de l'**annexe F** à l'autorité contractante figurant à la page 1 de la présente demande de propositions.

Question 7:

English:

Here are some questions regarding Solicitation No. W8486-217451/A:

- a) 2.2 (Page 5) – For the sample we need to send, can we drop it off in person ? If so, what date and time would be appropriate to drop the sample?
- b) 3.1 (Page 7) Section I Technical Bid – Is it possible to have an example of what you want exactly? “Bidders should explain and demonstrate how they propose to meet the requirements and how they will carry out the work”. Do you want to know how we will manage the production?
- c) 4.12.2 (Page 32) Package labelling – In the packaging instructions, it does not mention how you want the items to be packed? Does it need to be individually packed or in bulk?

French:

- a) 2.2 (Page 5) – Pour l'échantillon que nous devons envoyer, pouvons-nous le déposer en personne ? Si oui, quelle date et heure seraient appropriées pour déposer l'échantillon ?
- b) 3.1 (Page 7) Section I Soumission technique – Est-il possible d'avoir un exemple de ce que vous voulez exactement ? « Les soumissionnaires doivent expliquer et démontrer comment ils entendent répondre aux exigences et comment ils réaliseront les travaux ». Voulez-vous savoir comment nous allons gérer la production?
- c) 4.12.2 (Page 32) Étiquetage de l'emballage – Dans les instructions d'emballage, il ne mentionne pas comment vous souhaitez que les articles soient emballés ? Doit-il être emballé individuellement ou en vrac ?

Answer 7:

English:

- a) At this time samples will be mailed in as per the RFP
- b) Please refer to the request for proposal and Annex A to Annex F.
- c) The carrier and belt shall be packaged individually. The items shall be laid flat and packaged individually, in a polyethylene (or other transparent film) bag or envelope, made of material not less than one (1) mil thickness. The bags shall be taped or stapled to effect closure and shall be marked (labelled) as follows:
NATO Stock Number (NSN) * As specified on contract

Nomenclature * As specified on contract
Quantity / Unit of Issue - 1 EA
Bulk packaging for shipment to Depot shall be in accordance with D-LM-008-036/SF-000

French:

- a) À ce stade, des échantillons seront envoyés par la poste conformément au RFP
- b) Reportez-vous à la demande de proposition et à l'annexe A à l'annexe F.
- c) Le porte-masque et la ceinture doivent être emballés individuellement. Les articles doivent être posés à plat et emballés individuellement, dans un sac ou une enveloppe en polyéthylène (ou autre film transparent), fait d'un matériau d'au moins un (1) mil d'épaisseur. Les sacs doivent être scotchés ou agrafés pour effectuer la fermeture et doivent être marqués (étiquetés) comme suit :
Numéro de nomenclature OTAN (NSN) * Comme spécifié sur le contrat
Nomenclature * Comme spécifié sur le contrat
Quantité / Unité d'émission - 1 EA

L'emballage en vrac pour l'expédition au dépôt doit être conforme à D-LM-008-036/SF-000

Question 6:

English:

We have a couple of questions.

We are running into some material issues:

1. Buckle Centre-Bar, 1", Per Sealed Pattern DSSPM 411-08, 12-2-3A PLASTIC TO DWG #2839 CUS#21, good visual match to Coyote Brown 476/498
2. Loop, Strap Fastening, 1", Per Sealed Pattern DSSPM 411-08, (#19) UNIT 12-2-8A DWG #2840, good visual match to Coyote Brown 476/498
3. Webbing, Polyester, 14.2mm (\pm 1.0mm), DSSPM 2-2-80-151, Class II, Coyote Brown 476/498

The buckles appear to be obsolete and the webbing is a very uncommon size. We cannot find a source for pricing or samples.

Can we deviate to a more off the shelf solution? We could deviate to buckles and webbing that is currently used on other DND pouches.

French:

Nous avons quelques questions.

Nous rencontrons des problèmes matériels :

1. Boucle de fixation - barre centrale, 1", selon le modèle réglementaire DSSPM 411-08, 12-2-3A PLASTIC TO DWG #2839 CUS#21, bonne correspondance visuelle avec Brun Coyote 476/498
2. Boucle de fixation à courroie, 1", par modèle scellé DSSPM 411-08, (#19) UNIT 12-2-8A DWG #2840, bonne correspondance visuelle avec Brun Coyote 476/498

3. Sangle, Polyester, 14,2 mm (\pm 1,0 mm), DSSPM 2-2-80-151, Classe II, Brun Coyote 476/498

Les boucles semblent obsolètes et la sangle est d'une taille très rare. Nous ne pouvons pas trouver une source pour les prix ou les échantillons.

Pouvons-nous dévier vers une solution plus standard ? Nous pourrions nous écarter des boucles et des sangles actuellement utilisées sur d'autres pochettes du MDN.

Answer 6:

English:

Buckles: They must be Acetal. The resin properties of all Acetal parts must be in accordance with DuPont™ Delrin® 500AL NC010 Acetal Resin or equivalent and a good visual match to Coyote Brown 476/498. No sealed samples can be provided.

Webbing: A webbing that is 1/2" (12.7mm) or 5/8" (15.87mm) can be used as a substitution for the bid sample only, as per instructions listed in Annex D, para 2.6.

French:

Boucles: Elles doivent être en Acétal. Les propriétés de la résine de toutes les pièces en acétal doivent être conformes à la résine acétal DuPont™ Delrin® 500AL NC010 ou l'équivalent et une bonne correspondance visuelle avec Brun Coyote 476/498. Aucun échantillon réglementaire ne peut être fourni.

Sangle: Une sangle de 1/2" (12,7 mm) ou 5/8" (15,87 mm) peut être utilisée en remplacement seulement pour l'échantillon de soumission conformément aux instructions énumérées à l'annexe D, para 2.6.

Question 5 :

English

1. We are interested in applying for the gas mask carrier tender. I'm not very familiar with the process, are samples/materials provided that we can use to create samples for the application?
2. Also, the application deadline for this is currently Sept 9th, is that correct?

French

1. Nous aimerions présenter une soumission dans le cadre de l'appel d'offres pour le porte-masque à gaz. Toutefois, je ne connais pas bien le processus. Est-ce que des échantillons ou des matériaux sont fournis que nous pouvons utiliser pour fabriquer les échantillons pour la soumission?
2. La date limite pour présenter une soumission est actuellement fixée au 9 septembre, est-ce exact?

Answer 5:

English

1. As stated in section 2.6 of the RFP, a Technical Data Package (TDP) is available upon request. You will need to provide a completed copy of Annex F in the RFP, to the Contracting Authority.
2. The deadline to submit bids for this requirement is 21 September 2021 at 14h00 EDT

French

1. Comme il est mentionné au paragraphe 2.6 de la demande de propositions, un ensemble de données techniques est offert sur demande. Vous devez soumettre une copie dûment remplie de l'annexe F de la demande de propositions à l'autorité contractante.
2. La date limite pour présenter une soumission en réponse à ce besoin est le 21 Septembre 2021 à 14 h (HAE).

Question 4:

English

1. In the event we cannot source material in time that is compliant with the specifications, may we submit samples comprised of a similar material provided that we submit a letter confirming that all pre-production samples will be made in accordance with the contract requirements?

French

1. Dans le cas où nous ne pouvons pas nous procurer à temps des matériaux conformes aux spécifications, pouvons-nous soumettre des échantillons composés d'un matériau similaire à condition que nous soumettions une lettre confirmant que tous les échantillons de pré-production seront fabriqués conformément aux exigences du contrat?

Answer 4:

English

1. As per Annex D – Technical evaluation requirements, para 2.6 Material substitution, substitutions may be used.

French

1. Conformément à l'annexe D – Exigences d'évaluation technique, para 2.6 Substitution de matériaux, des substitutions peuvent être utilisées.

Question 3:

English

I have some questions concerning the request for proposal: W8486-217451/A.

1. When we will send you the sample with our bid, does it have to be in all the required materials? If we don't have the material on hand right now, is it possible to use other materials?

2. Is it possible for you to send us a sample of the gas mask carrier and the belt?
3. Also, I saw that we can have all the drawings upon request, can you send it to me please?

French

J'ai quelques questions concernant la demande de proposition: W8486-217451/A.

1. Lorsque nous vous enverrons l'échantillon avec notre offre, doit-il être dans tous les matériaux requis ? Si nous n'avons pas le matériel sous la main, est-il possible d'utiliser d'autres matériaux ?
2. Est-il possible pour vous de nous envoyer un échantillon du porte-masque à gaz et de la ceinture?
3. J'ai également vu qu'il était possible d'obtenir tous les dessins sur demande; pourriez-vous me les envoyer?

Answer 3:

English

1. As per Annex D – Technical evaluation requirements, para 2.6 Material substitution, substitutions may be used.
2. No sealed samples are available
3. Drawings will be sent once a completed copy of Annex F in the RFP is provided to the Contracting Authority.

French

1. Conformément à l'annexe D – Exigences d'évaluation technique, para 2.6 Substitution de matériaux, des substitutions peuvent être utilisées.
2. Aucun échantillon n'est disponible.
3. Les dessins seront envoyés dès qu'une copie dûment remplie de l'annexe F de la demande de propositions sera soumise à l'autorité contractante.

**NOTE (2) – English: Change to the Solicitation Closes –
L’invitation prend fin**

Delete :

At: – à :
14h00 EDT

On: – le :
23 August 2021

Insert :

At: – à :
14h00 EDT

On: – le :
07 September 2021

REMARQUE (2) – French : Changement L’invitation prend fin

Supprimer:

At: – à :
14h00 EDT

On: – le :
23 Août 2021

Insérer:

At: – à :
14h00 EDT

On: – le :
07 Septembre 2021

Question 2:

English

1. Para. 4.8.2 Marking of Belt; requests the information be stamped? Due to the pronounced texture of webbing DSSPM 2-2-80-151, can this information be stenciled using indelible ink?
Stamps do not work on textured webbings, because there is no “full surface contact” which leaves the marking unclear; even the sealed sample does not have any marking. Is Stamped vs Stenciled considered interchangeable in this case?
2. We have reviewed the paper patterns provided for the solicitation.
For the Left Side Carrier
The Belt Loop Reinforcement # 892 matches the profile placement set out on the main panel Piece# 881. Which also matches the sealed samples provided.

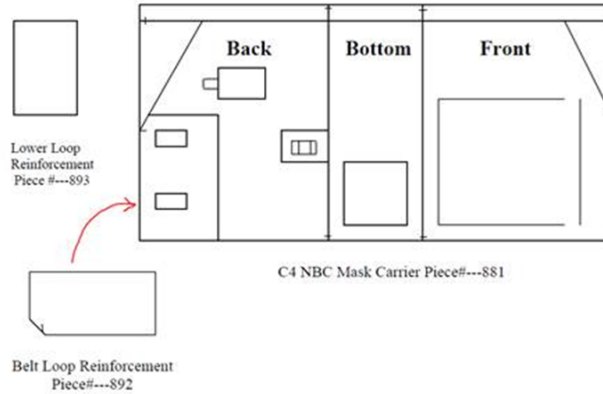

However on the Right Side Carrier patterns the main panel #881 is reversed but the Reinforcement # 892 is not, which does not match the construction of the sealed samples provided.
Should pattern # NBCMCRS892 be flipped and be a mirror image of NBCMCLS892?

French

1. Par. 4.8.2 Marquage de la ceinture ; demande que les informations soient estampé? En raison de la texture prononcée de la sangle DSSPM 2-2-80-151, cette information peut-elle être marquer au pochoir à l'aide d'une encre indélébile ?
Les estampe ne fonctionnent pas sur les sangles texturées, car il n'y a pas de « contact sur toute la surface » qui laisse le marquage peu clair ; même l'échantillon scellé n'a aucun marquage.
Est-ce que estampé vs au pochoir est-il considéré comme interchangeable dans ce cas?
2. Nous avons examiné les patrons de papier fournis pour la sollicitation.
Pour le porte-masque gauche
Le renfort du passant de ceinture n° 892 correspond à l'emplacement du profil indiqué sur le panneau principal, pièce n° 881. Ce qui correspond également aux échantillons scellés fournis.

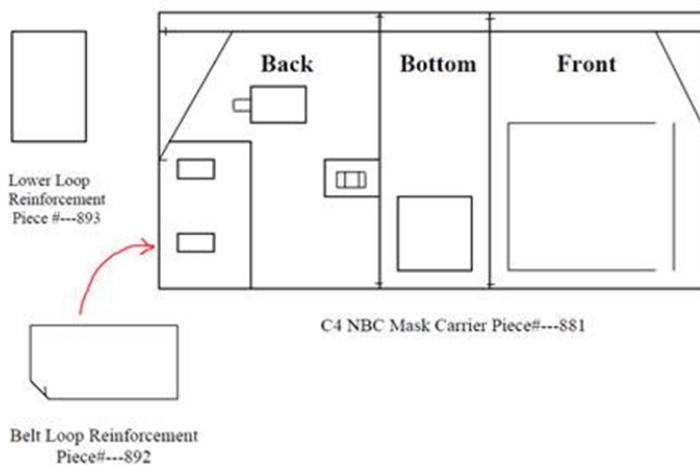

Cependant, sur les patrons de papier pour le porte-masque du côté droit, le panneau principal #881 est inversé mais le renfort #892 ne l'est pas, ce qui ne correspond pas à

la construction des échantillons scellés fournis. Le modèle # NBCMCRS892 devrait-il être inversé et être une image miroir de NBCMCLS892 ?

Answer 2 :

English

1. Yes, Stamped or stenciled can but used for marking purposes for the belt only.
2. Correct, The Belt Loop Reinforcement #892 should be flipped (mirror image) to coincide with the pattern for the right side only.

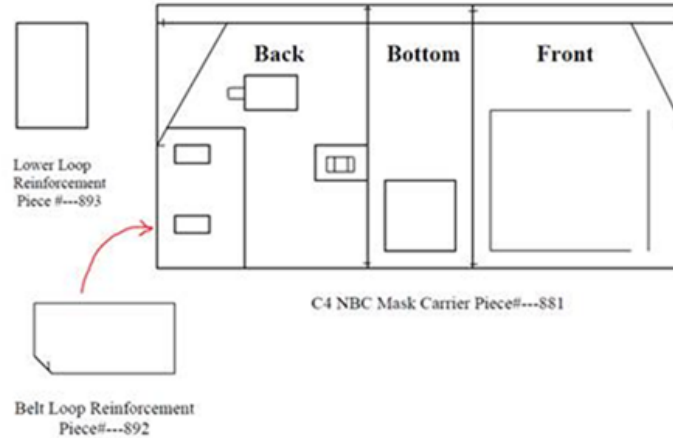

French

1. Oui, uniquement pour la ceinture, il peut être estampé ou au pochoir pour le marquage.
2. Correct, le renfort de boucle de ceinture #892 doit être inversé (image miroir) pour coïncider avec le patron pour le côté droit uniquement.

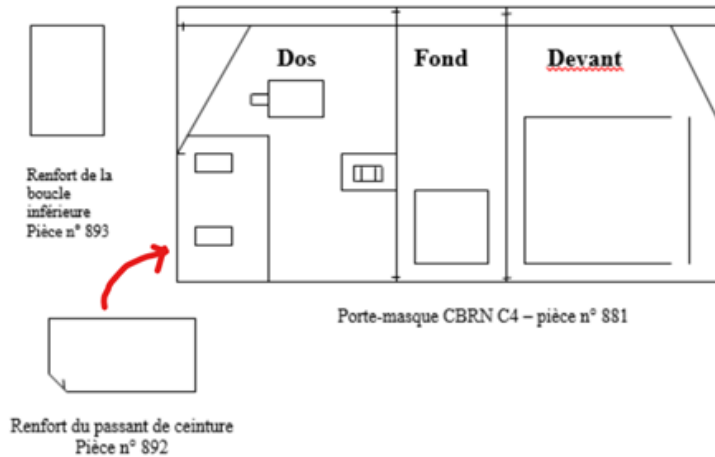

NOTE (1) - English: Correction to the Solicitation by adding appendices I, II, III, IV, V, VI, VII to ANNEX B (Manufacturing Data) – refer to page #9 below.

REMARQUE (1) - French: Correction à l'invitation en ajoutant les appendices I, II, III, IV, V, VI, VII à l'ANNEXE B (Données de fabrication) – reportez-vous à la page #9 ci-dessous.

Question 1:

English

Can you please assist with some answers?

In the Annex B (Manufacturing Data):

1. Para. 4.2.3 Webbing Nylon 25mm Coyote Brown; does the webbing require Infrared Reflectance per DSSPM 3-6-80-001?
2. Para. 4.2.4 Webbing Polyester 14.2mm; does the webbing require Infrared Reflectance per DSSPM 3-6-80-001?
3. Para. 4.2.5 c) Nylon Loop, 45mm wide; Specification A-A-55216 does not include 45mm fastener, should this be changed to 50mm fastener?
4. Para. 4.3.1 Webbing Polyester 25.4mm; does the webbing require Infrared Reflectance per DSSPM 3-6-80-001?
5. Para. 4.3.2 Buckle Center Bar; Is there a drawing available? does the Buckle require Infrared Reflectance per DSSPM 3-6-80-001?
6. Para. 4.3.3 Loop Strap Fastening; Is there a drawing available? does the Loop require Infrared Reflectance per DSSPM 3-6-80-001?
7. Para. 4.8.2 Marking of Belt; requests the information be stamped? Due to the pronounced texture of webbing DSSPM 2-2-80-151, can this information be stenciled, or affixed as a Sew-On Label?

French

1. Para 4.2.3 Sangle Brun coyote 25mm en nylon; la sangle nécessite-t-elle une réflectance infrarouge selon DSSPM 3-6-80-001 ?
2. Para 4.2.3 Sangle Polyester 14,2 mm; la sangle nécessite-t-elle une réflectance infrarouge selon DSSPM 3-6-80-001 ?
3. Para. 4.2.5 c) Rubans autoagrippants, 45 mm de large; La spécification A-A-55216 n'inclut pas la fixation de 45 mm, doit-elle être remplacée par une fixation de 50 mm?
4. Para 4.2.3 Sangle Polyester 25.4mm; la sangle nécessite-t-elle une réflectance infrarouge selon DSSPM 3-6-80-001 ?
5. Para 4.3.2 Boucle de fixation de barre centrale; Y a-t-il un dessin disponible? la boucle nécessite-t-elle une réflectance infrarouge selon DSSPM 3-6-80-001 ?

6. Para 4.3.3 Boucle de fixation à courroie; Y a-t-il un dessin disponible? la boucle nécessite-t-elle une réflectance infrarouge selon DSSPM 3-6-80-001 ?
7. Para. 4.8.2 Marquage de la ceinture; demande que les informations soient tamponnées? En raison de la texture prononcée de la sangle DSSPM 2-2-80-151, ces informations peuvent-elles être imprimées au pochoir ou apposées sous forme d'étiquette à coudre?

Answer 1:

English

1. Webbing does not fall under referenced specification and does not require infrared reflectance.
2. Webbing does not fall under referenced specification and does not require infrared reflectance.
3. 45mm tape is the equivalent of 1.75 inch tape. 50mm (2 inch) tape fastener may be used but will be cut with a hotknife or similar process to ensure no fraying occurs. It should be cut to shape to match the profile of the front pouch flap. Please refer to Appendix I (see page 6 below) and the sealed sample for further information and example. Webbing does not fall under referenced specification and does not require infrared reflectance.
4. Webbing does not fall under referenced specification and does not require infrared reflectance.
5. - Buckle center bar does not fall under referenced specification and does not require infrared reflectance.
 - No drawings are available for the 1 inch center bar, refer to the sealed sample if more information is required.
 - A photo has been provided as reference only. The buckle must meet all specifications and be representative of the sealed sample.



6. - Loop strap fastening does not fall under referenced specification and does not require infrared reflectance.
 - No drawings are available for the 1 inch loop strap fastener, refer to the sealed sample if more information is required.
 - Contrary to Annex B para 4.3.3, Three (3) loop strap fasteners will be required for the construction.

- A photo has been provided as reference only. The loop strap fastener must meet all specifications and be representative of the sealed sample.



7. No, the markings shall be made with indelible ink markings.

French

1. La sangle ne s'applique pas aux spécifications référencées et ne nécessite pas de réflectance infrarouge.
2. La sangle ne s'applique pas aux spécifications référencées et ne nécessite pas de réflectance infrarouge.
3. Les rubans autoagrippants de 45 mm équivaut à un ruban de 1,75 pouce. Un ruban autoagrippant de 50 mm (2 pouces) peut être utilisé mais doit être coupé avec un couteau à chaud ou un procédé similaire pour éviter tout effilochage. Il doit être découpé pour correspondre au profil du rabat avant de la poche. Veuillez-vous référer à l'appendice I (voir page 6 ci-dessous) et au modèle réglementaire pour plus d'informations et exemple.
4. La sangle ne s'applique pas aux spécifications référencées et ne nécessite pas de réflectance infrarouge.
5. - La Boucle de fixation de barre centrale ne s'applique pas aux spécifications référencées et ne nécessite pas de réflectance infrarouge.
 - Aucun dessin n'est disponible pour la barre centrale de 1 pouce, référez-vous au modèle réglementaire si plus d'informations sont nécessaires.
 - Une photo a été fournie à titre de référence seulement. La boucle doit répondre à toutes les spécifications et être représentative au modèle réglementaire.



6. - La Boucle de fixation à courroie ne s'applique pas aux spécifications référencées et ne nécessite pas de réflectance infrarouge.
- Aucun dessin n'est disponible pour fixation à courroie, référez-vous à l'échantillon scellé si plus d'informations sont nécessaires.
- Contrairement à l'Annexe B para 4.3.3, trois (3) attaches à boucle seront nécessaires pour la construction.
- Une photo a été fournie à titre de référence seulement. La boucle de fixation à courroie doit répondre à toutes les spécifications et être représentative de l'échantillon scellé.



7. Non, les marquages doivent être réalisés avec des marquages à l'encre indélébile.

Appendices I, II, III, IV, V, VI, VII to ANNEX B (Manufacturing Data)

APPENDIX I to ANNEX B

ASSEMBLY MANUAL FOR THE CBRN MASK CARRIER AND HARNESS ASSEMBLY

PAPER PATTERNS

The following pattern thumbnails are for guidance only. Proper paper will be supplied to contractor upon request.

I. CBRN Carrier Main Piece

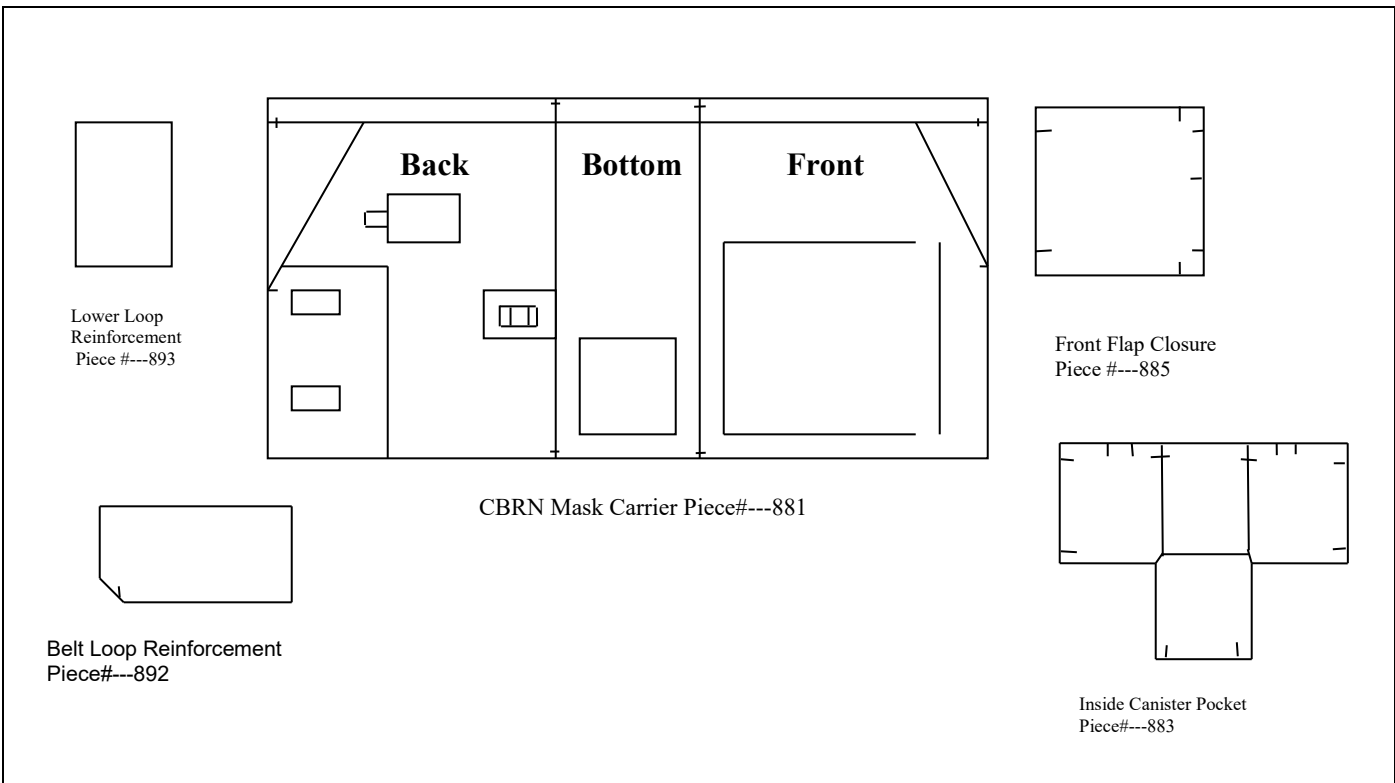

II. CBRN Carrier Side Pockets

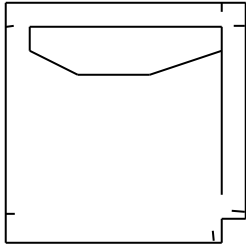

Top Side Pocket Piece#---882

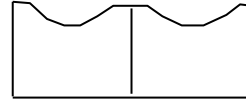

Chemical Agent Detector Pocket
Piece#---884

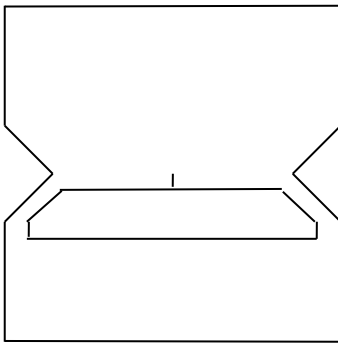

Side Pocket Flap
Piece #---890

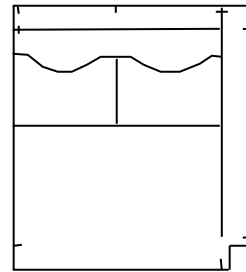

Side pocket Piece#---891

III. CBRN Carrier Back Wall Pocket

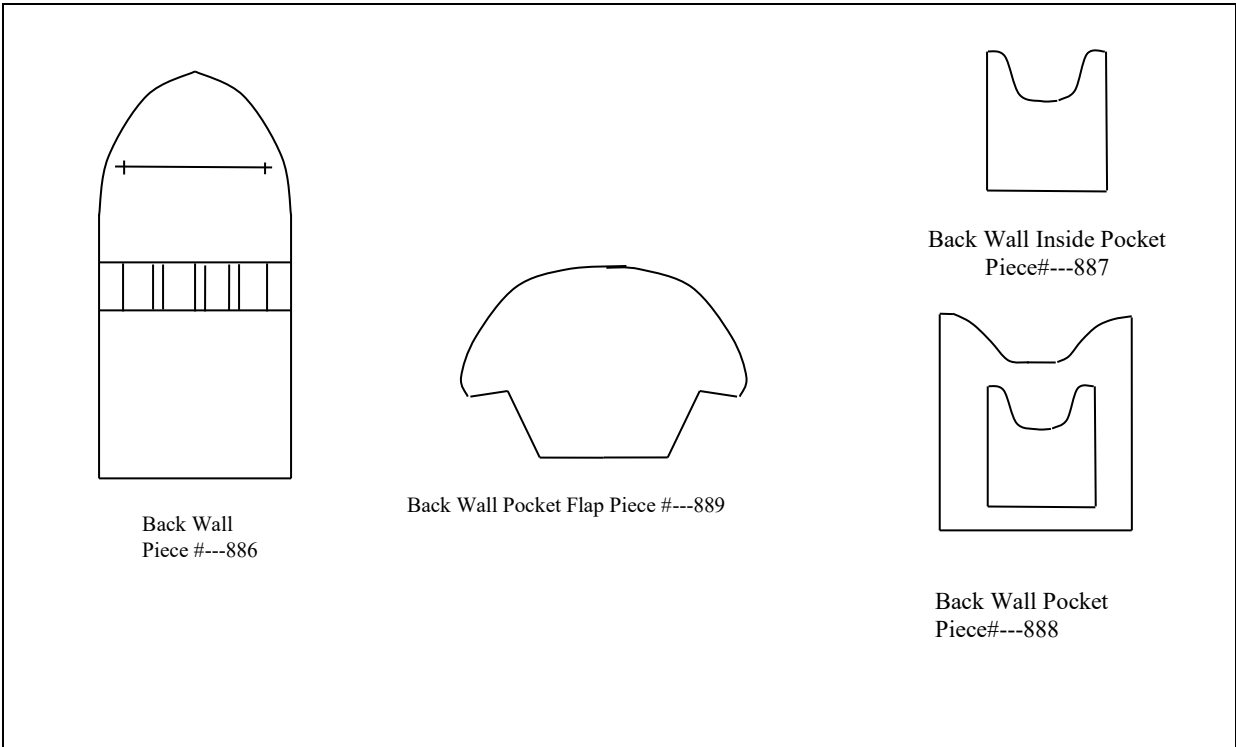

Instructions for manufacturing the CBRN Mask Carrier and Harness Assembly are provided for guidance only. The contractor is responsible for streamlining the production of the carrier and harness.

These assembly instructions refer to a left mounted carrier for a right handed person.

1. CBRN MASK CARRIER

1.1 Side pocket.

1.1.1 Sew 24.1 cm (9-½") length of binding onto the curved edge of the Chemical Agent Detector Pocket (piece #---884).

1.1.2 Using the guidelines on the pattern, sew the Chemical Agent Detector Pocket onto the wrong side of the Side Pocket (piece #--- 891).

1.1.3 Fold 2.5 cm (1") hem to the wrong side and stitch.

1.1.4 Prepare Pull Tab by sewing a 22.8 cm (9") length of 15.9 mm (5/8") webbing in half lengthwise and sewing around three sides. With the wrong side facing, sew the Pull Tab at the notch marked at the centre of the hem, inserting it 10 mm (25/64") in from the edge.

1.1.5 Centre a 2.5 cm (1") wide x 17.8 cm (7") length of hook tape over the hem and 4.8 mm (3/16") down from the top of the pocket. Sew all around, backstitching over the Pull Tab to secure.

1.1.6 Fold the Pull Tab over to the right side of the Side Pocket and stitch again, following the previous line of stitching used on the hook tape.

1.1.7 Sew the corner of the Side Pocket, right sides together and using the notches as a guide. Turn to the right side.

1.1.8 Fold the Side Pocket, wrong sides together, along the pattern lines. Edgestitch to corner, pivot and edgestitch to the other side of the pocket using the notch as a guide. This forms the partial cargo pocket.

1.1.9 Fold and "press" the two sides forming the cargo pocket under 10 mm (25/64").

1.2 Top side pocket.

1.2.1 Fold the hem as indicated by the notches on the pattern (piece #--- 882) to the wrong side and sew across.

1.2.2 Trim the corners of a 4.4 cm (1-¾") wide x 21.3 cm (8-⅜") length of loop tape to match the markings on the pattern. Sew all around.

1.2.3 Sew the corner of the Top Side Pocket, right sides together and using the notches as a guide. Turn to the right side.

1.2.4 Fold the Top Side Pocket, wrong sides together, along the pattern lines. Edgestitch to corner, pivot and edgestitch to the other side of the pocket using the notch as a guide. This forms the partial cargo pocket.

1.2.5 Fold and "press" the two sides forming the cargo pocket under 10 mm (25/64").

1.3 Side pocket flap.

1.3.1 Fold the Side Pocket Flap (piece #--- 890) in half with the right sides together and sew along the two short sides. Turn to the right side, turning out edges well.

1.3.2 Edgestitch all four sides.

1.3.3 Cut a 2.5 cm (1") wide x 14 cm (5-½") long length of loop tape fastener. Position on the right side

of the Side Pocket Flap, centered and 3.5 cm (1- $\frac{3}{8}$ ") down from the unstitched side. Lockstitch all around. This is to attach a name tag.

1.3.4 Prepare Pull Tab by sewing a 20.3 cm (8") length of 15.9 mm (5/8") webbing in half lengthwise and sewing around three sides. With the wrong side of the flap facing, sew the Pull Tab at the centre of the flap bottom edge, inserting it 2.5 cm (1") in from the edge.

1.3.5 Cut the corners of 2.5 cm (1") wide x 21.6 cm (8- $\frac{1}{2}$ ") length of hook tape to the angles indicated on the pocket flap. Centre over the Pull Tab on the wrong side of the flap and 10 mm (25/64") from the edges, as indicated on the pattern piece.

1.4 Assemble side pocket.

1.4.1 Place the prepared Top Side Pocket on top of the Side pocket, matching the lower edges exactly. Baste down the left side of the pocket assembly.

1.4.2 Edgestitch the right sides together, all the way down the bottom sides, lining up the edges carefully.

1.4.3 Place this pocket assembly on the right side of the Carrier Shell according to the placement lines on the pattern. Edgestitch around the two sides stopping at bottom left corner.

1.4.4 Fold right side of the pocket assembly under 10 mm (25/64") and edgestitch to the bottom, following the placement lines on the pattern.

1.4.5 Pivot as you turn the corner and stitch through all layers of the pocket for 3.8 cm (1- $\frac{1}{2}$ ").

1.4.6 Reinforce with another vertical row of stitching 6.4 mm ($\frac{1}{4}$ ") away from the first row and for a distance of 19.1 mm ($\frac{3}{4}$ ").

1.4.7 Place Side Pocket Flap on the placement lines according to the pattern. Sew using a 6.4 mm ($\frac{1}{4}$ ") seam allowance. Fold down and topstitch.

1.5 Inside canister pocket.

1.5.1 Place a 2.5 cm (1") wide x 12.7 cm (5") long piece of elastic between one pair of notches on pattern piece #---883.

1.5.2 Sew on a 31.1 cm (12- $\frac{1}{4}$ ") length of binding, covering the elastic end, sewing around to the other side and placing the remaining end of elastic under the binding between the notches. The elastic should go over the top of the canister pocket.

1.5.3 With wrong sides together, fold along the lines as indicated on the pattern and edgestitch both sides.

1.5.4 Fold the canister pocket to sew the corners, with wrong sides together and sew.

1.5.5 Place the Inside Canister Pocket on the wrong side of the Carrier Shell according to the markings on the pattern. Sew around the three sides of the pocket, maintaining a distance of 4.8 mm (3/16") minimum. There is no need to finish or tuck under the raw edges of the fabric.

1.6 Back of carrier.

1.6.1 Sew on the Belt Loop Reinforcement (piece #---892) and the Lower Loop Reinforcement (piece #---893) to the markings on the wrong side of the Carrier Shell (piece #---881). The right side of the reinforcement should be in contact with the wrong side of the carrier.

1.6.2 Prepare Belt Loop by cutting a length of 2.5 cm (1") wide webbing x 24.7 cm (9 ¾"). Fold one end up 19.1 mm (¾") and place a 2.5 cm (1") wide x 8.9 cm (3-½") length of hook tape on the webbing, 6.4 mm (¼") from the folded edge. Sew all around.

1.6.3 Fold the remaining end of the webbing under 19.1 mm (¾") and place a 2.5 cm (1") x 8.9 cm (3-½") length of loop tape even with the folded edge. Sew a 5.1 cm (2") box through the loop tape and webbing. This should leave a 3.8 cm (1-½") length of loop tape hanging free. Turn the end of the loop tape under 9.5 mm (¾") and sew edges securely.

1.6.4 Repeat Steps 1.6.2 and 1.6.3 to make a second Belt Loop.

1.6.5 Place the Belt Loops on the right side of the Carrier according to the marks on the pattern. The loop tape should be closest to the Leg Strap. Sew with a full box stitch.

1.6.6 Cut a 2.5 cm (1") wide x 7.9 cm (3-1/8") length of webbing for the guide for the Leg Strap. Fold edges under 15.9 mm (5/8") and stitch with two rows of lockstitch placed 3.2 mm (1/8") from the folded edges and 6.4 mm (¼") apart. The 2.5 cm (1") Leg Strap must run freely through the guide.

1.6.7 Cut a 2.5 cm (1") wide x 22.2 cm (8-¾") length of webbing for the Security Closure Strap. Fold one end 9.5 mm (¾") two times and lockstitch through all three layers of webbing. Place a 2.5 cm (1") wide x 6 cm (2-¾") length of hook tape 19.1 mm (¾") from the folded edge and stitch all around. The folds should not show from the hook tape side.

1.6.8 Cut a 10.2 cm (4") wide x 5.1 cm (2") length of loop tape and place on the right side of the Carrier. Insert the strap prepared at Step 1.6.7 under the loop tape directly opposite the marking for the hook tape. Sew the loop tape all around.

1.6.9 Cut a 2.5 cm (1") wide x 5.7 cm (2-¼") length of loop tape, place on the right side of the Carrier according to the marks on the pattern and sew all around.

1.6.10 Fold the top edge of the Carrier opening under 6.4 mm (¼") to the wrong side. Fold again to the wrong side at 3.2 cm (1-¼") and stitch 2 mm (1/16") from the double folded edge.

1.6.11 Fold the Carrier with wrong sides together, along the lines indicated on the pattern, defining the bottom of the Carrier. Edge stitch from the opening to within 2.5 cm (1") of the notch on the other side.

1.6.12 Fold the Carrier right sides together, lining up the hem and the edge stitching defining the bottom of the Carrier. Edgestitch for a length of 8.5 cm (3-11/32") and backstitch well.

1.6.13 Insert the Duraflex strip cut to a 2.5 cm (1") width with one end angled to meet the pattern lines. There should be one on either side of the edge stitching made at Step 1.6.11.

1.6.14 Fold the Carrier with wrong sides together along the diagonal lines indicated on the pattern. Edgestitch.

1.7 **Back wall pocket.**

1.7.1 On the right side of the Back Wall (piece #---886) sew a 5.1 cm (2") wide x 30.5 cm (12") length

of elastic to the lines indicated on the pattern. Sew the first line, mark the elastic at 6.3 cm (2-½") and bring this mark to meet the next line on the pattern. Sew with two rows of lockstitch spaced 6.4 mm (¼"). Mark the elastic at 6.3 cm (2-½") and bring this mark to the next line on the pattern, Sew with two rows of lockstitch spaced 6.4 mm (¼") apart. Repeat until there are four bubbles of elastic.

1.7.2 Sew a 33 cm (13") binding on the top edges of the Back Wall Pocket (piece #---888) and a 14 cm (5-½") length of the Back Wall Inside Pocket (piece #---887).

1.7.3 Sew 4.4 cm (1-¾") wide x 12.1 cm (4-¾") loop tape to the right side of the Back Wall Pocket.

1.7.4 Topstitch the Back Wall inside Pocket to the wrong side of the Back Wall Pocket, 4.8 mm (3/16") away from the cut edges. There is no need to turn under the raw edges.

1.7.5 Pleat the bottom edges of the Back Wall Pocket, matching the notches. Sew/Baste to the right side of the Back Wall.

1.7.6 Sew 33.7 cm (13-¼") length of binding to the outer edge of the Back Wall Pocket Flap (piece #---889).

1.7.7 Prepare a Pull Tab by folding a 20.3 cm (8") length of 15.9 mm (5/8") webbing in half and stitching around three sides.

1.7.8 With the wrong side of the Back Wall Pocket Flap facing up, place the Pull Tab at the centre with a 2.5 cm (1") overlap. Sew securely 3 times with a back and forth lockstitch.

1.7.9 Place a 2.5 cm (1") wide x 11.4 cm (4-½") long piece of hook tape over the Pull Tab., centering it. Sew all around.

1.7.10 With right sides together, sew the corners with a 10 mm (25/64") seam. Turn to right side, fold seam allowance to the centre of the pocket flap and edgestitch.

1.7.11 Place the right side of the Back Wall Pocket Flap to the right side of the Back Wall according to the placement lines on the pattern and using a 6.4 mm (¼") seam allowance. Turn down and topstitch flap in place.

1.8 Assemble carrier.

1.8.1 Place the point of the Back Wall to the long side of the Carrier, right sides together. Starting at a point 10 mm (25/64") from either side, sew the Back Wall to the Carrier, matching the notches on the Carrier to the corners of the Back Wall, and continuing around to the starting point. On that same edge, sew binding tape to the length required, cut, fold end of binding tape under and then sew and backstitch.

1.8.2 Fold seam allowances to the Carrier side and topstitch all around.

1.8.3 With right sides together, sew across to the top of the carrier. On that same edge, sew binding tape to the length required, cut, fold end of binding tape under and then sew and backstitch. Turn to the right side and fold the bound edge toward the Side Pocket and topstitch.

1.8.4 Fold three edges of the Front Flap Closure (piece #---885) 10 mm (25/64") to the wrong side. Cut a 33 cm (13") length of 15.9 mm (5/8") webbing. Fold in half and sew all around. Sew to Front Flap at notch, with the wrong side facing. Cut a 10.2 cm (4") wide x 10.2 cm (4") length of hook tape. Place hook tape on the wrong side of the Front Flap Closure. Sew all around, securing the folded edges and the Tab well. Fold the Tab to the right side of the flap and stitch 12.7 mm (½") away with 3x back and forth. Place the right side of the prepared flap to the opening of the Carrier 7 cm (2-¾") from the bottom of the Carrier on the side with the Side Pocket. Sew following the stitching line on the hem and again 3.2

mm (1/8") from the opening of the Carrier.

1.9 Leg strap.

1.9.1 Cut a 2.5 cm (1") wide x 101.6 cm (40") length of webbing. Fold one end under 3.5 cm (1-3/8"). Slide on a Female Side Release Buckle. Fold again to 5.1 cm (2") Sew through all three layers of webbing with a 3.3 cm (1-5/16") long full box stitch. Cut a 2.5 cm (1") wide x 7.6 cm (3") length of elastic, fold in half and sew with a 10 mm (25/64") seam allowance, anchoring stops and starts well. Sew a second row 3.2 mm (1/8") from cut edges to reinforce. Thread a Male Side Release Buckle on the remaining end. Fold end up twice at 15.9 mm (5/8") and stitch through the centre of all three layers 3 times with a back and forth stitch. Thread Leg Strap through the Leg Strap Guide on the Carrier.

1.10 Name tag.

1.10.1 Cut 2.5 cm (1") wide hook tape x 14 cm (5-1/2") long. Cut a length of 2.5 cm (1") webbing x 14 cm (5-1/2") long. Heat seal the cut edges. Lockstitch the webbing to the hook tape. This will be used as a name tag for the Gas Mask Carrier.

2. HARNESS ASSEMBLY

2.1 Waist strap.

2.1.1 Cut a length of the 2.5 cm (1") webbing to measure 176.5 cm (69-1/2") long.

2.1.2 Make a mark 15.2 cm (6") from one end of the webbing. Thread the webbing end over the center post of the Slip Lock Buckle and bring to mark. Sew with a 38 mm (1-1/2") Full Box Stitch, lined up to the cut webbing end.

2.1.3 Slide a Male Stealth Warrior Buckle onto the other end of the webbing, pushing it close to the Full Box Stitch.

2.1.4 Thread the free webbing end back through the Slip Lock Buckle.

2.1.5 Mark the remaining end of the webbing at 12.7 cm (5"). Slip on a female buckle and bring end to meet mark, folding to the right side of the waist strap. Sew with a 3.8 cm (1-1/2") Full Box Stitch. Sew back and forth three times with a single line of lockstitch close to buckle.

2.2 Shoulder strap.

2.2.1 Cut 2.5 cm (1") webbing to measure 27.3 cm (10-3/4") long.

2.2.2 Make a mark 10.8 cm (4-1/4") from one end. Slide on Common Loop A and bring webbing to meet the mark.

2.2.3 Slide Common Loop B onto the other end of the webbing. Fold webbing to meet Common Loop A, tucking it between the two layers. Stitch the end of the webbing down 3 times with a back and forth lockstitch.

2.2.4 Move the Common Loops to either end of the webbing loop, matching up marks made earlier. Sew close to the Common Loop A with a 2.5 cm (1") Full Box Stitch.

- 2.2.5 Make a 3x back and forth line of lockstitch close to Common Loop B.
- 2.2.6 Cut a length of 2.5 cm (1") webbing that measures 160 cm (63") long.
- 2.2.7 Make a mark 12.7 cm (5") from one end of the webbing. Thread the webbing around the center post of the Slip Lock Buckle and bring to mark. Sew with a 2.5 cm (1") Full Box Stitch, lined up to the webbing end.
- 2.2.8 Slide the end of the webbing through Common Loop A. Thread the webbing back through the Slip Lock Buckle.
- 2.2.9 Make a mark 20 cm (8") from the remaining end of the webbing. Thread a Common Loop on to the webbing, folding the webbing under to meet the mark.
- 2.2.10 Sew a 2.5 cm (1") full box stitch 3.2 mm (1/8") away from the cut end.
- 2.2.11 With the Common Loop pulled against the fold in the webbing, stitch three times with a back and forth lockstitch. There should be 5.1 cm (2") space between the stitching at the Common loop and the full box stitch to allow the Waist strap of the Harness to run freely.

2.3 **Assemble harness.**

- 2.3.1 Insert the Waist Strap into the Shoulder Harness.

Note that the Harness is suitable for left handed and right handed individuals by reversing the direction the Waist Strap is fed through the Shoulder Harness.

APPENDIX II to ANNEX B

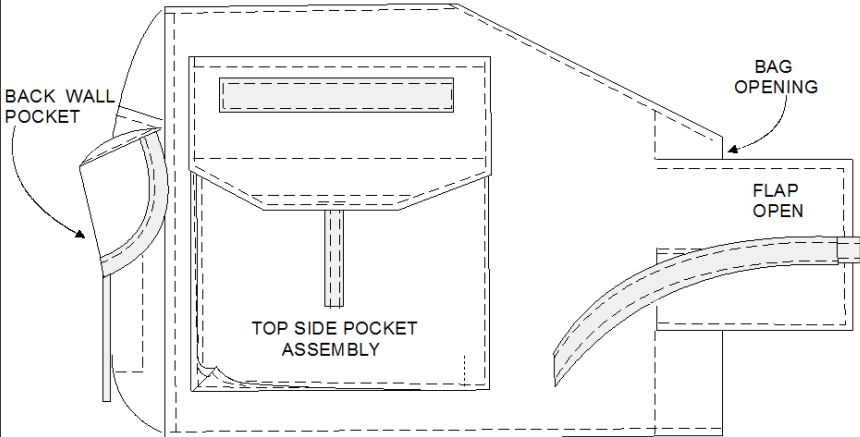
| CBRN MASK CARRIER | |
|---|---|
| STYLE CODE: | NBCMCRS0 (RIGHT) NBCMCLS0 (LEFT) |
| DESIGN: | <p>Front flap closure fastened with hook and loop, with pull-tab and security strap for quick access and accidental opening; self-hemmed pocket inside with a one-inch length of elastic to secure the spare canister; two belt loops for attachment to harness assembly or a belt; leg strap with a side release buckle to anchor the carrier; partial cargo design pockets with hook and loop closure and pull-tab closure for storage of chemical agent detectors and syringes; carrier is available in a version of right side and left side, printed in CADPAT™.</p> |
| |  |
|  <p align="center">FRONT VIEW OF RIGHT SIDE CARRIER</p> <p align="center">*ALL DRAWINGS SHOWN ARE OF THE RIGHT SIDE CARRIER VIEW (LEFT SIDE CARRIER IS THE MIRROR OPPOSITE)</p> | |

CBRN MASK CARRIER

STYLE CODE: NBCMCRS0 (RIGHT) NBCMCLS0 (LEFT)



PATTERN PIECE REFERENCE

| Pattern Piece Description | Piece ID Code | QTY | Pattern Piece Description | Piece ID Code | QTY |
|----------------------------------|---------------|-----|----------------------------------|---------------|-----|
| Material A: Shell | | | | | |
| RIGHT SIDE BAG | | | LEFT SIDE BAG | | |
| CBRN GAS MASK CARRIER BAG (BODY) | NBCMCRS881 | 1 | CBRN GAS MASK CARRIER BAG (BODY) | NBCMCLS881 | 1 |
| TOP SIDE POCKET | NBCMCRS882 | 1 | TOP SIDE POCKET | NBCMCLS882 | 1 |
| INSIDE CANISTER POCKET | NBCMCRS883 | 1 | INSIDE CANISTER POCKET | NBCMCLS883 | 1 |
| CHEMICAL AGENT DETECTOR POCKET | NBCMCRS884 | 1 | CHEMICAL AGENT DETECTOR POCKET | NBCMCLS884 | 1 |
| FRONT FLAP CLOSURE | NBCMCRS885 | 1 | FRONT FLAP CLOSURE | NBCMCLS885 | 1 |
| BACK WALL | NBCMCRS886 | 1 | BACK WALL | NBCMCLS886 | 1 |
| BACK WALL INSIDE POCKET | NBCMCRS887 | 1 | BACK WALL INSIDE POCKET | NBCMCLS887 | 1 |
| BACK WALL POCKET | NBCMCRS888 | 1 | BACK WALL POCKET | NBCMCLS888 | 1 |
| BACKWALL POCKET FLAP | NBCMCRS889 | 1 | BACKWALL POCKET FLAP | NBCMCLS889 | 1 |
| SIDE POCKET FLAP | NBCMCRS890 | 1 | SIDE POCKET FLAP | NBCMCLS890 | 1 |
| SIDE POCKET | NBCMCRS891 | 1 | SIDE POCKET | NBCMCLS891 | 1 |
| BELT LOOP REINFORCEMENT | NBCMCRS892 | 1 | BELT LOOP REINFORCEMENT | NBCMCLS892 | 1 |
| LOWER LOOP REINFORCEMENT | NBCMCRS893 | 1 | LOWER LOOP REINFORCEMENT | NBCMCLS893 | 1 |
| | | | | | |
| | | | | | |

THE NUMBER IN THE QUANTITY COLUMN REFERS TO THE NUMBER OF PIECES REQUIRED TO CONSTRUCT ONE SAMPLE.

CBRN MASK CARRIER

STYLE CODE: NBCMCRS0 (RIGHT) NBCMCLS0 (LEFT)



TECHNICAL DRAWINGS CARRIER FRONT

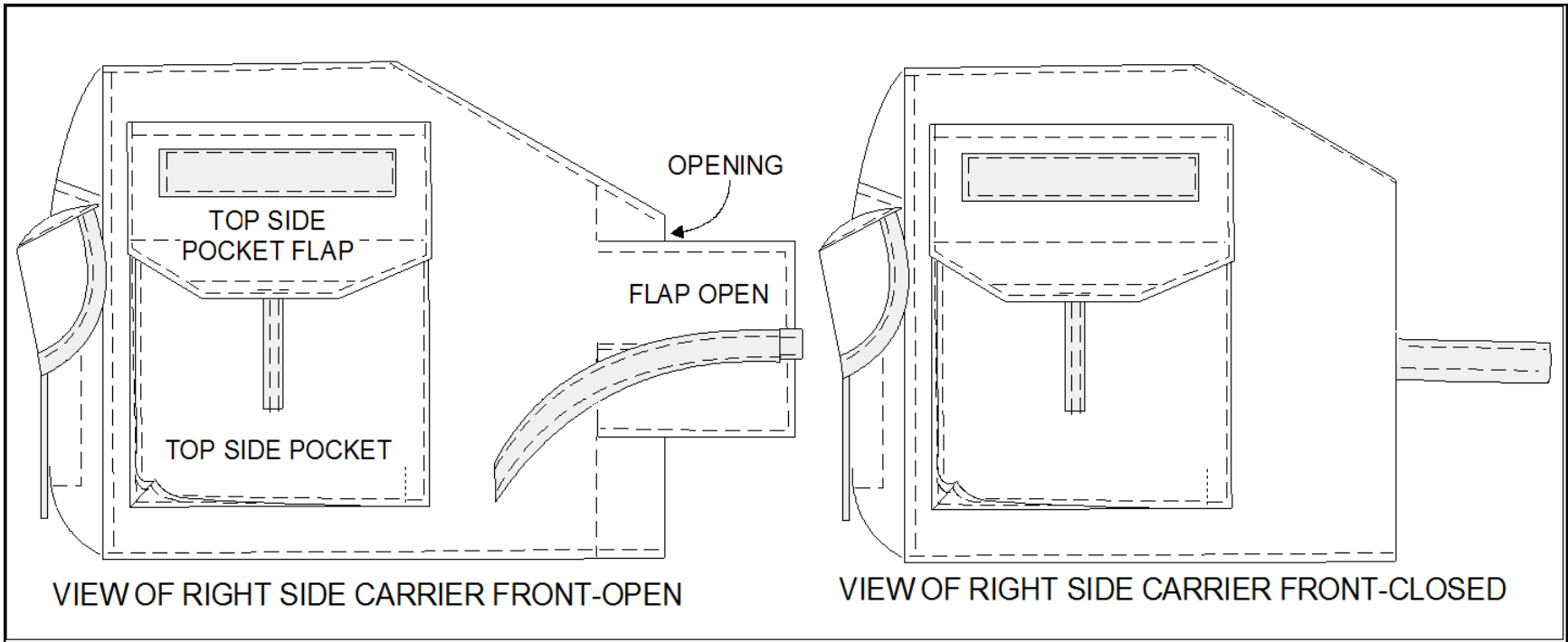

CBRN MASK CARRIER

STYLE CODE: NBCMCRS0 (RIGHT) NBCMCLS0 (LEFT)

TECHNICAL DRAWINGS CARRIER BACK

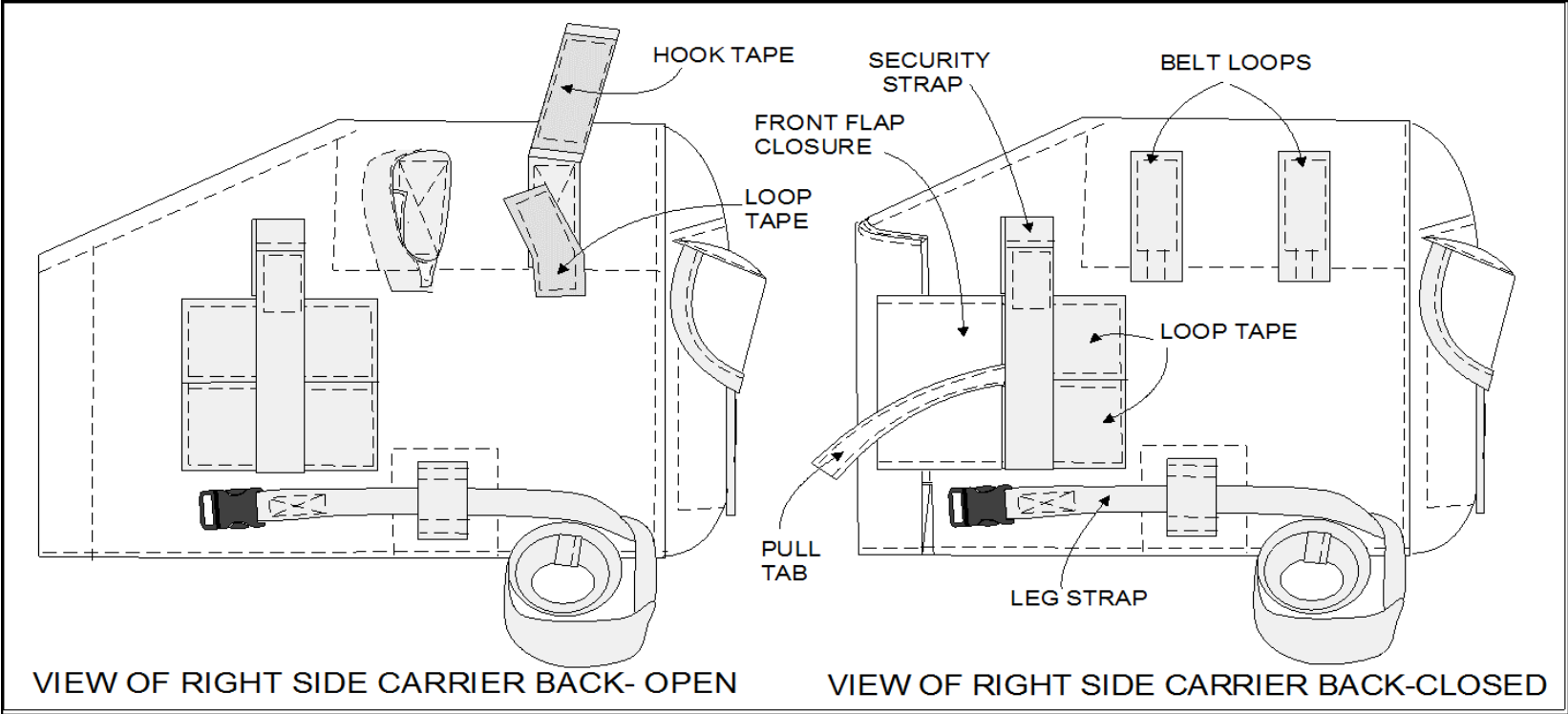

CBRN MASK CARRIER

STYLE CODE: NBCMCRS0 (RIGHT) NBCMCLS0 (LEFT)

TECHNICAL DRAWINGS BACKWALL POCKET

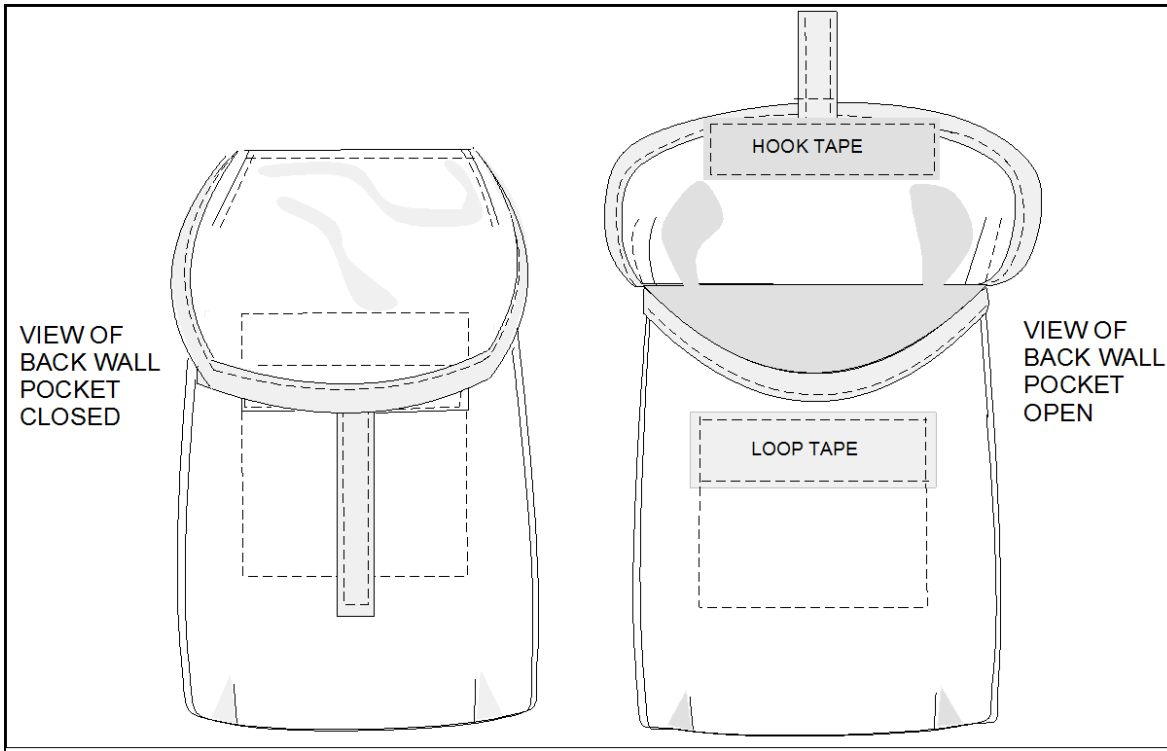

CBRN MASK CARRIER

STYLE CODE: NBCMCRS0 (RIGHT) NBCMCLS0 (LEFT)

TECHNICAL DRAWINGS BACK WALL POCKET ASSEMBLY AND INTERIOR

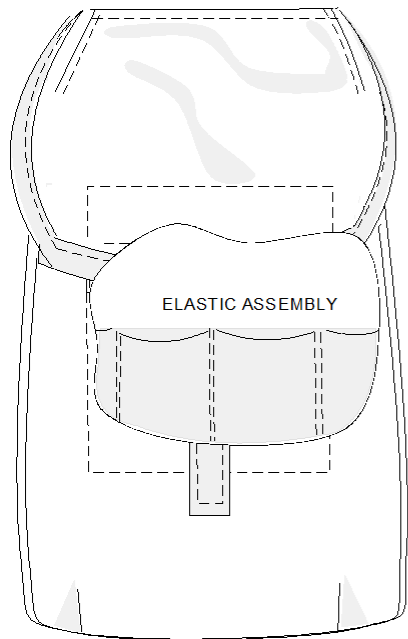

**CUT-AWAY VIEW OF
BACKWALL POCKET**

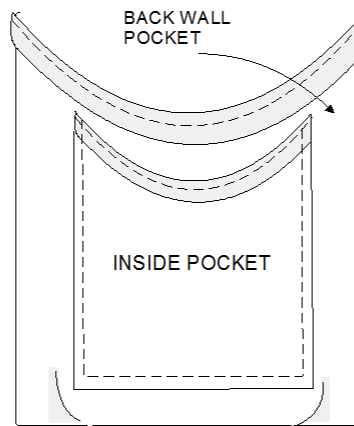

**VIEW OF BACK WALL
POCKET WRONG SIDE**

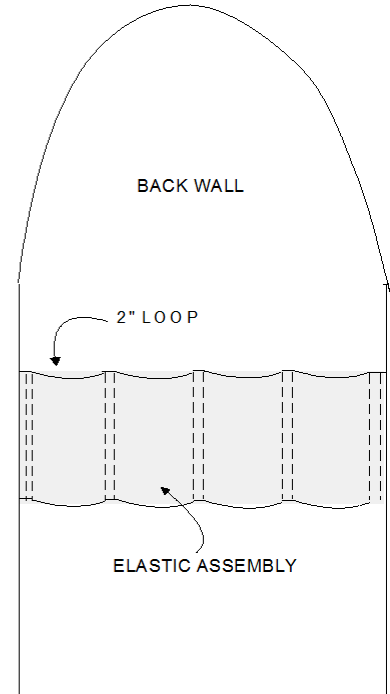

**VIEW OF BACK WALL
ELASTIC ASSEMBLY**

CBRN MASK CARRIER

STYLE CODE: NBCMCRS0 (RIGHT) NBCMCLS0 (LEFT)

TECHNICAL DRAWINGS CARRIER BOTTOM AND CARRIER TOP

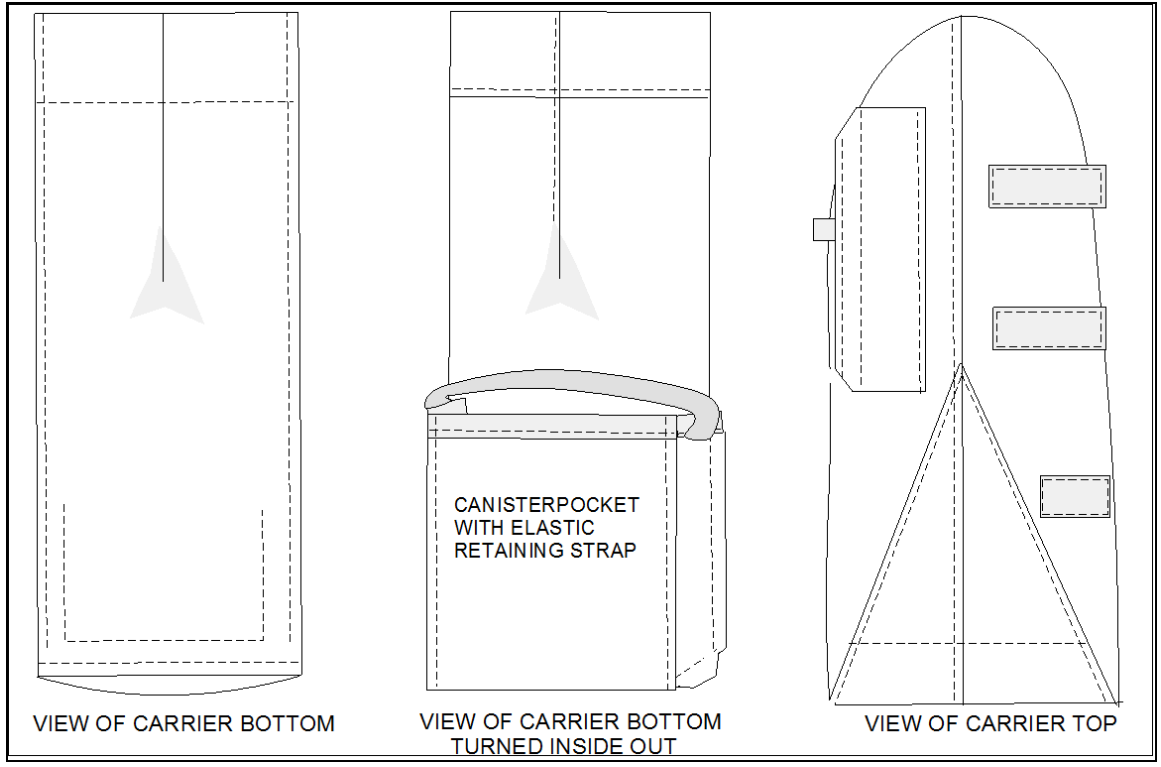

CBRN MASK CARRIER

STYLE CODE: NBCMCRS0 (RIGHT) NBCMCLS0 (LEFT)

TECHNICAL DRAWINGS TOP SIDE POCKET ASSEMBLY

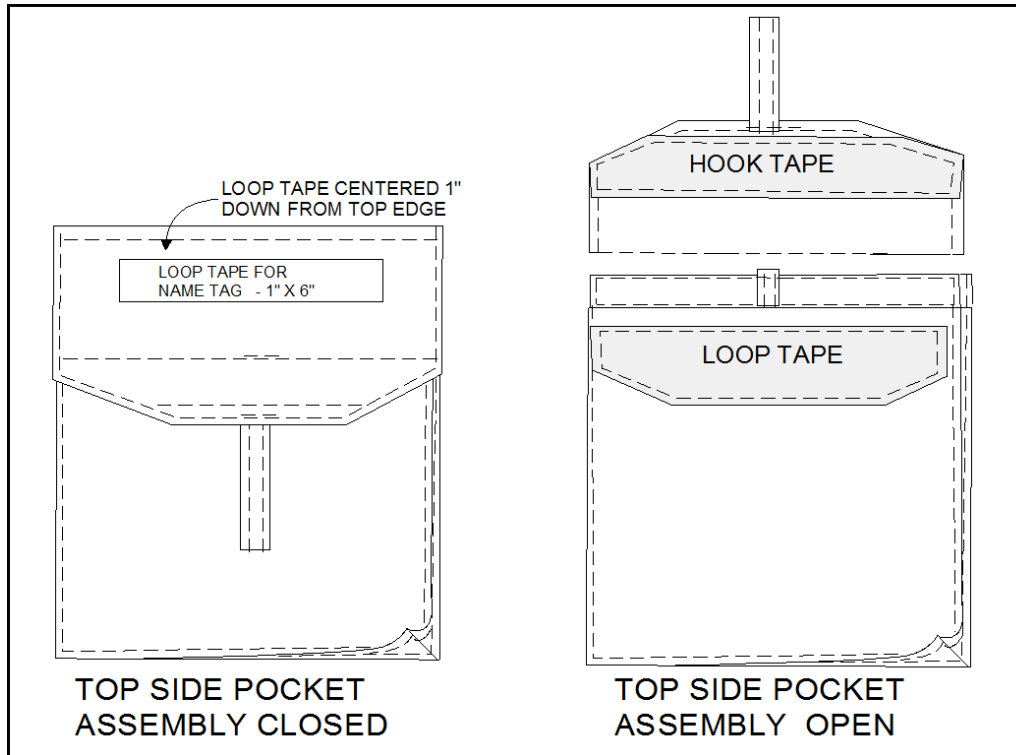

CBRN MASK CARRIER

STYLE CODE: NBCMCRS0 (RIGHT) NBCMCLS0 (LEFT)

TECHNICAL DRAWINGS TOP SIDE POCKET ASSEMBLY LAYERS

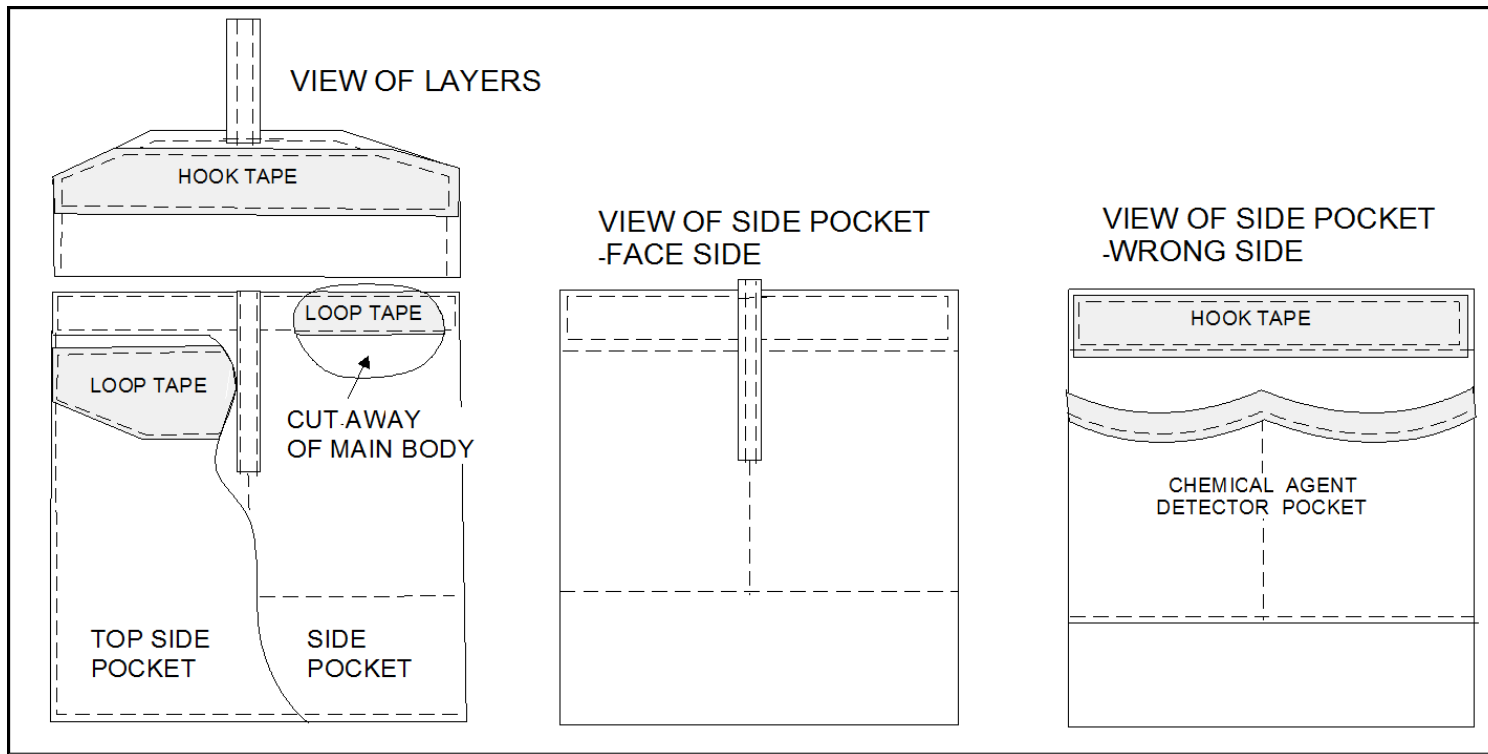

CBRN MASK CARRIER

STYLE CODE: NBCMCRS0 (RIGHT) NBCMCLS0 (LEFT)

TECHNICAL DRAWINGS FRONT OPENING STIFFENER



LOCATION AND SIZE

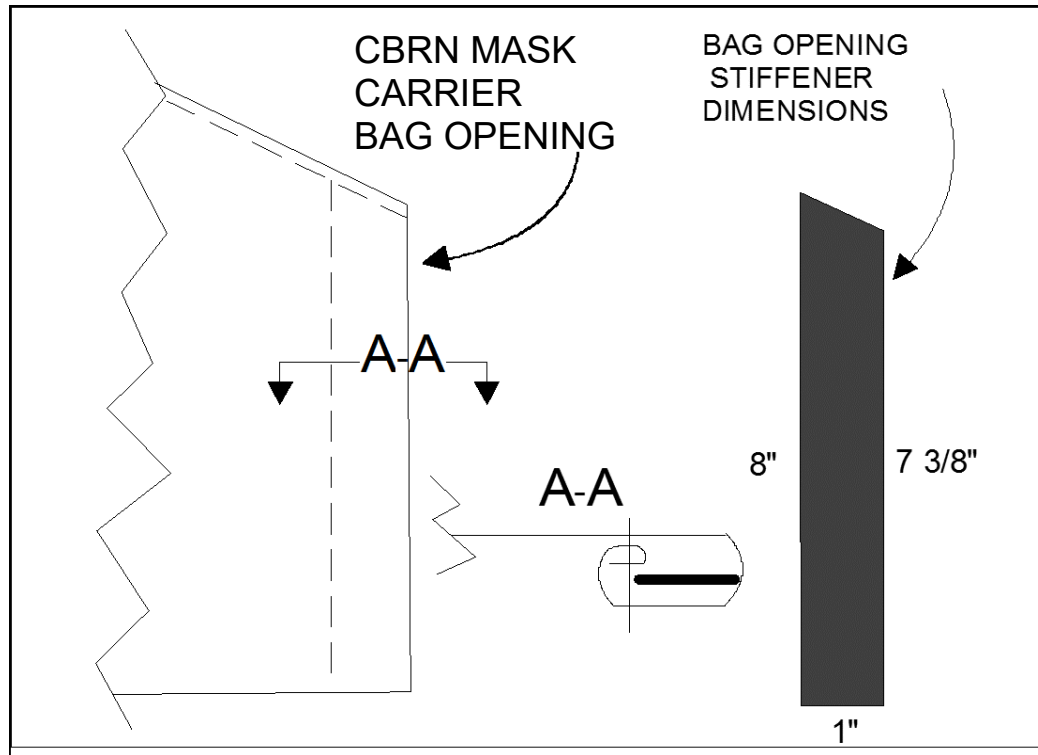

APPENDIX III to ANNEX B

**LINEAR PROPERTIES
CM (Inches)**

CBRN MASK CARRIER

2. 5 cm (1) wide, Nylon Webbing

| ITEM | CUT LENGTH | # OF PIECES | TOTAL LENGTH | FINISH LENGTH |
|--------------------------------|-------------------|------------------------|---------------------|----------------------|
| Belt Loops | 25 (9.75) | 2 | 50 (19.5) | 20.3 (8) |
| Leg Strap | 100 (39.5) | 1 | 100 (39.5) | 88.2 (34.75) |
| Security Strap - Front Closure | 22.2 (8.75) | 1 | 22.2 (8.75) | 19 (7.5) |
| Guide for Leg Strap | 8 (3.125) | 1 | 8 (3.25) | 5.4 (2.125) |
| Name Tag | 14 (5.5) | 1 | 14 (5.5) | 14 (5.5) |

2 cm (3/4) wide Binding Tape

| ITEM | CUT LENGTH | # OF PIECES | TOTAL LENGTH | FINISH LENGTH |
|-----------------------------|-------------------|------------------------|---------------------|----------------------|
| Chemical Agent Detector Pkt | 24.0 (9.5) | 1 | 24.0 (9.5) | 24.0 (9.5) |
| Flap – Back Wall Pocket | 33.7 (13.25) | 1 | 33.7 (13.25) | 33.7 (13.25) |
| Back Wall Pocket | 33 (13) | 1 | 33 (13) | 33 (13) |
| Inside Pocket, Back Wall | 14 (5.5) | 1 | 14 (5.5) | 14 (5.5) |
| Inside Canister Pocket | 31.1 (12.25) | 1 | 31.1 (12.25) | 31.1 (12.25) |

1.6 cm (5/8) wide, CADPAT™ Print Webbing

| ITEM | CUT LENGTH | # OF PIECES | TOTAL LENGTH | FINISH LENGTH |
|--------------------------|-------------------|------------------------|---------------------|----------------------|
| Front Tab, Opening Tab | 33 (13) | 1 | 33 (13) | 15.9 (6.25) |
| Side Pocket Opening Flap | 20.3 (8) | 1 | 20.3 (8) | 7.9 (3.125) |
| Back Wall Pocket Tab | 20.3 (8) | 1 | 20.3 (8) | 7.9 (3.125) |
| Side Pocket Tab | 22.8 (8) | 1 | 22.8 (8) | 9.5 (3.75) |

2. 5 cm (1) wide Elastic

| ITEM | CUT LENGTH | # OF PIECES | TOTAL LENGTH | FINISH LENGTH |
|--------------------|-------------------|------------------------|---------------------|----------------------|
| Keeper – Leg Strap | 7.6 (3) | | 7.6 (3) | 7.6 (3) |
| Canister Pocket | 12.7 (5) | | 12.7 (5) | 12.7 (5) |

4.5 cm (2) wide Elastic

| ITEM | CUT LENGTH | # OF PIECES | TOTAL LENGTH | FINISH LENGTH |
|------------------|-------------------|------------------------|---------------------|----------------------|
| Back Wall Pocket | 30.5 (12) | 1 | 30.5 (12) | 30.5 (12) |

2.5 cm (1) Tape Fastener, Hook

| ITEM | CUT LENGTH | # OF PIECES | TOTAL LENGTH | FINISH LENGTH |
|-----------------------|-------------------|------------------------|---------------------|----------------------|
| Side Pocket Flap | 21.6 (8.5) | 1 | 21.6 (8.5) | 21.6 (8.5) |
| Side Pocket | 17.8 (7) | 1 | 17.8 (7) | 17.8 (7) |
| Back Wall Pocket | 11.5 (4.5) | 1 | 11.5 (4.5) | 11.5 (4.5) |
| Belt Loops | 8.9 (3.5) | 2 | 17.8 (7) | 8.9 (3.5) |
| Security Closure Flap | 6.0 (2.375) | 1 | 6.0 (2.375) | 6.0 (2.375) |
| Name Tag | 14 (5.5) | 1 | 14 (5.5) | 14 (5.5) |

2.5 cm (1) Tape Fastener, Loop

| ITEM | CUT LENGTH | # OF PIECES | TOTAL LENGTH | FINISH LENGTH |
|-----------------------|-------------------|------------------------|---------------------|----------------------|
| Shell – Inside Pocket | 17.8 (7) | 1 | 17.8 (7) | 17.8 (7) |
| Belt Loops | 8.9 (3.5) | 2 | 17.8 (7) | 8.9 (3.5) |
| Security Closure Flap | 5.7 (2.25) | 1 | 5.7 (2.25) | 5.7 (2.25) |
| Name Tag | 14 (5.5) | 1 | 14 (5.5) | 14 (5.5) |

4.5 cm (1 ¾) Tape Fastener, Loop

| ITEM | CUT LENGTH | # OF PIECES | TOTAL LENGTH | FINISH LENGTH |
|------------------|-------------------|------------------------|---------------------|----------------------|
| Top Side Pocket | 21.3 (8.375) | 1 | 21.3 (8.375) | 21.3 (8.375) |
| Back Wall Pocket | 12 (4.75) | 1 | 12 (4.75) | 12 (4.75) |

10 cm (4) Tape Fastener, Hook

| ITEM | CUT LENGTH | # OF PIECES | TOTAL LENGTH | FINISH LENGTH |
|--------------------------|-------------------|------------------------|---------------------|----------------------|
| Front Flap Closure – Tab | 10.2 (4) | 1 | 10.2 (4) | 10.2 (4) |

10 cm (4) Tape Fastener, Loop

| ITEM | CUT LENGTH | # OF PIECES | TOTAL LENGTH | FINISH LENGTH |
|----------------------------|-------------------|------------------------|---------------------|----------------------|
| Front Closure Flap – Shell | 10.2 (4) | 1 | 10.2 (4) | 10.2 (4) |

HARNESS ASSEMBLY

| ITEM | CUT LENGTH | # OF PIECES | TOTAL LENGTH | FINISH LENGTH |
|------------------------------------|-------------------|------------------------|-------------------------|----------------------|
| Waist Strap | 165 (65) | 1 | 165 (65) | 150 (50) |
| Shoulder Strap | 160 (63) | 1 | 160 (63) | 145 (57) |
| Shoulder/Waist Attachment Strap | 25.4 (10) | 1 | 25.4 (10) | 10.2 (4) |

APPENDIX IV to ANNEX B

**HIGH DENSITY POLYETHYLENE PHYSICAL PROPERTIES
(DURAFLEX)**

| PROPERTY | METHOD | SPECIFIED REQUIREMENT |
|-------------------------|---------------|------------------------------|
| TENSILE YIELD STRENGTH | *D 638 | 34 Mpa ±3 |
| ULTIMATE ELONGATION | *D 638 | >800% |
| FLEXURAL MODULUS | *D 790 | 1240 Mpa ±15 |
| HARDNESS | *D 2240 | 69 Shore D ±4 |
| BRITTLENESS TEMPERATURE | *D 746 | 125°C ± 5 |
| DENSITY | *D1505 | 2.1 G/CM ³ ± 0.06 |

* ASTM – American Society of Testing & Materials

APPENDIX V to ANNEX B

SIDE RELEASE BUCKLE REQUIREMENTS

Introduction

This Appendix outlines the Side Release Buckle technical and operational description, tests methods and the performance requirements that the buckle must meet..

The contractor shall ensure that the buckle he will supply under this contract must conform to the performance requirements of Tables I and II and III and Appendix VII. An accredited laboratory familiar with buckle testing shall conduct all testing. Should a non-accredited laboratory be required for specific tests, approval shall be sought and received in writing from the Design Authority in advance.

Design and Operational Characteristics

Dimensions

The SR buckle should have safe designed pull strength of no less than 80kg \pm 5 (180 lbs \pm 12). The overall dimensions shall be as per table 1.

| 25 mm Side Release Buckle Overall dimensions: Tolerances unless otherwise specified \pm 0.4 mm | | | | |
|--|---------------|---------------|--------------|-----------------|
| Part | Length | Height | Width | Comments |
| Buckle | 60 | 14 | 35 | |
| Male | 50 | 10 | 35 | |
| Female | 42 | 14 | 35 | |

Table 1 – Buckle Dimensions

Buckle Test Preparation

Prior to testing, the buckles shall be conditioned for a minimum of 40 hours at 23 \pm 2°C and 50 \pm 5% RH, as per ASTM D638. A deviation in the conditioning environment to 65 \pm 2% relative humidity and 20 \pm 2°C is permitted.

The tests required are pull test, chemical resistance test, chemical exposure + pull test, and low-temperature/wet test.

Test Procedures

Pull Test

This test consists of pulling the buckle apart at a rate of 50mm/min (2 inch/min); the maximum sustained load shall be reported for every buckle. The test will be performed at room temperature (23°C), low temperature (-40°C), and high temperature (+45°C). Buckles will conditioned at the test temperature for a minimum of 30 minutes prior to testing. Five (5) buckles will be used at each temperature. An average of the 5 maximum sustained loads shall be calculated at each temperature.

II. Chemical Resistance Test

This test method consists of applying a small amount of the contaminant, hereby referenced as test fluid, onto the buckle surface for a given period of time, removing the contaminant, and examining the contaminated surface for any defect. An exposure time of 2 hours shall be used to represent the accidental aspect of the contamination. The test fluids are listed in table II.

| Test Fluids | |
|---------------------|------------------------|
| JP-4 turbine fluid | (MIL-DTL-5624) |
| Diesel fuel | (CGSB 3.6) |
| DEET – liquid | (NSN 6840-21-903-0036) |
| DEET – cream | (NSN 6840-01-284-3982) |
| Methyl Ethyl Ketone | (MEK) |

Table III - Test Fluids

One (1) buckle will be tested in each fluid. Testing will be performed at room temperature (23°C).

Prepare a test pad that will consist of a glass microfiber filter, 2.1 cm in diameter, such as Whatman's 934-AH (catalog number 1827 021). In addition, prepare a microscope slide cover glass of sufficient area to cover the test pad, such as a No. 2 [18mm sq.] cover glass by Corning Glass Works.

Thoroughly wet the test pad by drenching it in the test fluid. Immediately, place the test pad on the horizontal specimen (buckle). Cover with the cover glass to minimise evaporation. The test pad shall be kept thoroughly wet during the exposure time. Check for degradation of the buckle material.

III. Chemical Exposure + Pull Test

This test consists of immersing the complete buckle in the test fluid for one (1) hour at room temperature (23°C), and subjecting it to the pull test detailed paragraph 5 while still wet. This test will indicate if the buckle is prone to environmental stress cracking. One (1) buckle shall be used for each test fluid and pull test. The maximum sustained load shall be recorded.

IV. Low Temperature/Wet Test (ease of operation)

This test will evaluate the buckle's ease of one-handed operation when cold and wet. Testing shall be performed at -40°C. Three (3) buckles shall be used for this test.

The buckle shall be immersed in distilled water and immediately placed in a temperature chamber set at -40°C. After soaking at this temperature for 1 hour, the buckle shall be operated in the chamber (i.e. one-hand release attempted), and a qualitative evaluation shall be reported. A dry/cold buckle shall be used as a reference for this test.

Buckle Requirements

Table III outlines the performance requirements of the buckle after exposure to the above tests.

| Test | Test Conditions | # of Buckles | Minimum Requirement |
|---|------------------------|---------------------|---|
| I. Pull Test | 23°C | 5 | 210 lbs average, with individual value not less than 200 lbs |
| | -40°C | 5 | 310 lbs average, with individual value not less than 290 lbs |
| | +45°C | 5 | 195 lbs average, with individual value not less than 180 lbs |
| II. Chemical Resistance | Turbine fluid/ 23°C | 1 | No degradation in buckle material |
| | Diesel / 23°C | 1 | No degradation in buckle material |
| | DEET / 23°C | 1 | No degradation in buckle material |
| | MEK / 23°C | 1 | No degradation in buckle material |
| III. Chemical Exposure + Pull Test | Turbine fluid/ 23°C | 1 | 200 lbs |
| | Diesel / 23°C | 1 | 200 lbs |
| | DEET / 23°C | 1 | 200 lbs |
| | MEK / 23°C | 1 | 200 lbs |
| IV. Low Temp / wet, "Ease of operation" test | Wet / -40°C | 3 | Release of the buckle with one hand operation Buckle must remain operational |

TABLE III - BUCKLE REQUIREMENTS

APPENDIX VI to ANNEX B

Colour of Materials - CBRN Mask Carrier and Harness Assembly

| C4 Gas Mask Carrier | CADPAT™ (TW) 8465-20-002-5354 8465-20-002-5355 | CADPAT™ (AR) 8465- 20-002-5351 8465- 20-002-5352 | CADPAT™ (MT) NSN:TBD NSN:TBD |
|---|---|---|---|
| Carrier Fabric | CADPAT™ (TW) | CADPAT™ (AR) | CADPAT™ (MT) |
| Print Specification | DSSPM 3-6-80-001 | DSSPM 3-6-80-001 | DSSPM 3-6-80-001 |
| Thread | Canadian Average Green | Light Sand | Coyote Brown |
| Tab Openings | CADPAT™ (TW) | CADPAT™ (AR) | CADPAT™ (MT) |
| Webbing – MIL-W-17337 | Canadian Average Green | Light Sand | Coyote Brown |
| Tape Fastener | Canadian Average Green | Light Sand | Coyote Brown |
| Elastic Keeper MIL-T-17964 | Canadian Average Green | Light Sand | Coyote Brown |
| 25mm Elastic- Commercial | Black or White | Black or White | Black or White |
| 50mm Elastic- Commercial | Black or White | Black or White | Black or White |
| Binding Tape MIL-T-5038 | Canadian Average Green | Light Sand | Coyote Brown |
| Side Release Buckles Male and Female | Canadian Average Green | Light Sand | Coyote Brown |

| Harness Assembly | For Carriers in CADPAT™ (TW) and (AR) 8465-20-002-5356 | For Carriers in CADPAT™ (MT) NSN:TBD |
|---|---|---|
| Webbing D-80-001-151/SF-001 | Canadian Average Green | Coyote Brown |
| Thread | Canadian Average Green | Coyote Brown |
| Sliplock buckle | Canadian Average Green | Coyote Brown |
| Common Loop | Canadian Average Green | Coyote Brown |
| Side Release Buckles Male and Female | Canadian Average Green | Coyote Brown |

APPENDIX VII to ANNEX B
Acetal (Delrin®) Specifications for
Buckle/ Cordlock/ Common Loop & Zipper pull

Properties and Characteristics

The characteristics of Delrin® resins include:

- a. High tensile strength, impact resistance, and stiffness.
- b. Outstanding fatigue endurance.
- c. Excellent resistance to moisture, gasoline, solvents, and many other neutral chemicals.
- d. Excellent dimensional stability.
- e. Good electrical insulating characteristics.
- f. Good resilience and resistance to creep.
- g. Natural lubricity.
- h. Wide end-use temperature range

Acetal (Delrin® 500 AL NC010)

| Property | Test Method | Units | Value |
|---|-------------|----------------|------------------------|
| Mechanical | | | |
| Tensile strength at yield 5mm/min (0.2in/min) | ASTM D 638 | Mpa (kpsi) | 66 (9.6) |
| Elongation at Yield 5mm/min (0.2in/min) | ASTM D 638 | % | 10 |
| Elongation at Break 5mm/min (0.2in/min) | ASTM D 638 | % | 30 |
| Tensile Modulus 5mm/min (0.2in/min) | ASTM D 638 | Mpa (kpsi) | 3170 (460) |
| Flexural Modulus | ASTM D 790 | Mpa (kpsi) | 2970 (430) |
| Flexural Stress | ASTM D 790 | Mpa (kpsi) | |
| Strain 5% | | | 88 (12.8) |
| Izod Impact | ASTM D 256 | J/m (ft lb/in) | 58 (1.1) |
| Thermal | | | |
| Heat Deflection Temperature 0.45MPa (66psi), Not annealed | ASTM D 648 | °C (°F) | 169 (336) 108 (226) |
| 1.8MPa (264psi), Not Annealed | ASTM E 831 | E-4/C | 1.18 |
| CLTE, Parallel 25 – 55°C (73-130°F) | ASTM E 831 | E-4/C | 1.16 |
| CLTE, Parallel 25 – 55°C (73-130°F) | ASTM D 3418 | °C (°F) | 178 (352) |
| Melting Point | | | |
| Flow | | | |
| Melt Flow Rate 1.05kg at 190C | ASTM D 1238 | g/10 min | 6 |
| Electrical | | | |
| Surface Resistivity | ASTM D 257 | ohm | 4 E15 |
| Volume Resistivity | ASTM D 257 | ohm cm | 7 E17 |
| Dielectric Strength, Short Time | ASTM D 149 | kV/mm (V/mil) | 17.7 (450) |
| 3.2mm (0.126in) | ASTM D 150 | | 3.6 |
| Dielectric Constant 1E6 Hz | ASTM D 150 | | 0.006 |
| Dissipation Factor 1E6 Hz | | | |
| Flammability | | | |
| Rating @ Min. Thickness | UL94 | | HB |
| Min. Thickness Tested | UL94 | Mm (in) | 0.75 (0.03) |
| Other | | | |
| Specific Gravity | ASTM D 792 | | 1.39 |
| Mold Shrinkage | ASTM D 955 | % | |
| Flow, 24h, 3.2mm (0.126in) | | | 1.7-2.0 |
| Transverse, 24h, 3.2mm (0.126in) | | | 1.7-2.0 |
| Processing | | | |
| Melt Temperature Range | | °C (°F) | 210-220 (410-430) |
| Mols Temperature Range | | °C (°F) | 80-100 (175-210) |
| Processing Moisture Content | | % | <0.2 |