

**RETURN BIDS TO:****RETOURNER LES SOUMISSIONS À:**

See Section 1.

Voir Section 1.

**STANDARD REQUEST FOR BID****INVITATION À SOUMISSIONNER - STANDARD**

The Bidder offers to provide to Canada the goods, services or both listed in the bid solicitation in accordance with the conditions set out in the bid solicitation and the prices set out in the bid.

This bid solicitation is issued in accordance with the conditions of the Supply Arrangement E60PQ-140003/PQ.

Le soumissionnaire offre de fournir au Canada les biens, services ou les deux énumérés dans la demande de soumissions aux conditions prévues dans la demande de soumissions et aux prix indiqués dans la soumission.

Cette demande de soumissions est émise conformément aux conditions de l'arrangement en matière d'approvisionnement E60PQ-140003/PQ.

Solicitation No. - N° de la demande <b>5000061175</b>	Amendment No. - N° de modification
Supplier SA No. E60PQ-140003/___	

Solicitation closes – La demande prend fin :	File No. - N° de dossier
at – à See Section 1 Voir Section 1	<b>5000061175</b>
on – le See Section 1 Voir Section 1	

No of Page/

N° de page 1/14

Date of Solicitation – Date de la demande

**07 September 2021**

Address inquiries to – Adresser toute demande de renseignement à :

See Section 2, Article 4.1.

Voir Section 2, Article 4.1

Destination

See Section 2, Annex A.

Voir Section 2, Annexe A.

Instructions:

Municipal taxes are not applicable.

Unless otherwise specified in the bid solicitation, all prices quoted must be net prices in Canadian funds including Canadian customs duties, excise taxes, must be FOB, including all delivery charges to destination(s) as indicated. The amount for Applicable Taxes is to be shown as a separate item.

Instructions:

Les taxes municipales ne s'appliquent pas.

Sauf indication contraire dans la demande de soumissions, tous les prix indiqués doivent être des prix nets, en dollars canadiens, comprenant les droits de douane canadiens, la taxe d'accise et doivent être FAB, y compris tous frais de livraison à la (aux) destination(s) indiqué(s). Le montant des taxes applicables doit apparaître séparément.

Supplier Name and Address – Nom et adresse du fournisseur

Telephone No. - N° de téléphone

Facsimile No. - N° de télécopieur

Name and title of person authorized to sign on behalf of supplier (type or print)

Nom et titre de la personne autorisée à signer au nom du fournisseur (caractère d'impression)

Signature : \_\_\_\_\_ Date : \_\_\_\_\_

## TABLE OF CONTENTS

Section 1 – Invitation and Instructions to Bidders

Section 2 – Resulting Contract including a list of required goods and services

### SECTION 1 – INVITATION AND INSTRUCTIONS TO BIDDERS

**Step 1. For Tier 2 and Tier 3 only (If Tier 1, skip this step and proceed with step 2)**

**Step 2.  Competitive or  Non-Competitive**

For competitive Requirements when only one bid is received:

A bid must comply with the requirements of the bid solicitation and meet all mandatory technical evaluation criteria to be declared responsive. The responsive bid with the lowest evaluated price will be recommended for award of a contract.

For Competitive Requirements when only one bid is received:

The Bidder must provide the following information AFTER bid closing, if requested to do so by Canada:

- One or more of the following price justifications:
  1. a current published price list indicating the percentage discount available to Canada; or
  2. a copy of paid invoices for the like quality and quantity of the goods, services or both sold to other customers; or
  3. a price breakdown showing the cost of direct labour, direct materials, purchased items, engineering and plant overheads, general and administrative overhead, transportation, etc., and profit; or
  4. any other supporting documentation as requested by Canada.

For Non-Competitive Requirements:

The Bidder must provide the following information WITH the bid:

- One or more of the following price justifications:
  1. a current published price list indicating the percentage discount available to Canada; or
  2. a copy of paid invoices for the like quality and quantity of the goods, services or both sold to other customers; or
  3. a price breakdown showing the cost of direct labour, direct materials, purchased items, engineering and plant overheads, general and administrative overhead, transportation, etc., and profit; or
  4. any other supporting documentation as requested by Canada.

**Step 3.  General or  PSAB**

#### **Terms of the RFB:**

This RFB is issued pursuant to the Supplier's Furniture for Workspaces Supply Arrangement (SA) that forms part of the series of SAs issued by PWGSC with the number **E60PQ-140003/PQ**. The terms and conditions in the Supplier's SA apply to and form part of this RFB. Bidders who submit a bid agree to be bound by those terms and conditions as well as the terms and conditions in this RFB.

The WTCM is the Workspaces Terms and Conditions Manual that contains all terms and conditions in full text that form part of individual RFBs under this SA. The Bidder must provide the following information WITH the bid:

- The information requested by Canada in Annex A herein.

**Bid Evaluation**

An evaluation team composed of representatives of Canada and will evaluate the bids.

<b>RFB Issued by:</b>	
Identified User's (IU) Department/Agency/Crown Corporation: Contact for this RFB:	See Section 2, article 4.1 below.
<b>RFB Closing - Submit Bid:</b> Bids must be submitted on the date and at the time indicated below.	
By no later than date and time:	a. <b>21 September 2021</b> b. <b>14:00 EDT</b>
To physical location (if applicable)	Not applicable
To e-mail address (if applicable)	<b>moufid.samri@ec.gc.ca</b>
<b>RFB Enquiries</b>	
Unless a different period is listed in the adjacent column, Bidders may submit enquires about the RFB to the Contracting Authority two business days prior to the RFB closing date. Enquiries received after the timeline indicated may not be answered.	<b>02 business days</b>

**SECTION 2 - RESULTING CONTRACT CLAUSES**

<b>1.</b>	<b>Terms and Conditions of the Contract</b>	
	The terms and conditions of Parts 6B and 6C of the Supplier's SA within the series E60PQ-140003/PQ apply to and form part of this Contract.	
<b>2.</b>	<b>Security Requirement</b> (the checked article applies)	
2.1	The applicable security requirement(s) is (are) set out in the Security Requirement Check List attached as Annex B of this contract. The Contractor must fulfill the security requirements by meeting the terms below.	
a.		<b>Contractor may be escorted; possession of security clearance not required.</b> Contractor personnel MAY NOT ENTER NOR PERFORM WORK ON sites where PROTECTED or CLASSIFIED information or assets are kept, without an escort provided by the department or agency for which the work is being performed.
b.		<b>Possession of security clearance(s) is required.</b> The Contractor must meet the security clearance requirements contained in the clausing in Annex B herein.
c.	X	<b>There is no security requirement associated with this contract.</b>
<b>3.</b>	<b>Requirement</b>	
3.1	The Contractor must perform the Work listed in Annex A herein.	
<b>4.</b>	<b>Authorities</b>	
4.1	<b>Contracting Authority (IU)</b>	
	Name:	<b>Moufid Samri</b>
	Title:	Procurement Specialist
	Department/Agency/Crown Corporation:	Environnement et Changement climatique Canada
	Address:	105, McGill, 5 <sup>th</sup> flr Montreal (Québec) - H2Y 2E7
	Telephone No.:	514-496-2617
	E-mail address:	<a href="mailto:moufid.samri@ec.gc.ca">moufid.samri@ec.gc.ca</a>
4.2	<b>Project Authority</b> [ <i>To be completed at contract award</i> ]	

	<p><i>The Project Authority (PA) is the representative of the department or agency for whom the Work is being carried out under the Contract including the provision to approve the authority to proceed for delivery and installation and is responsible for all matters concerning the technical content of the Work under the Contract.</i></p> <p><i>In addition, the PA is also responsible for ensuring that the Supplier's employees and subcontractors requiring access to the site adhere to the allocated time for the Supplier to access the site to deliver and install the furniture in accordance with the master schedule held by the General Contractor (a representative of Canada or a service provider(s) under contract with the Government of Canada).</i></p>	
	Name:	
	Title:	
	Department/Agency/Crown Corporation:	
	Address:	
	Telephone No.:	
	E-mail address:	
4.3	<b>Contractor's Representative</b>	
	As set out in Annex A, Table 9 below.	
5.	<b>Method of Payment</b>	
	The checked box applies. If the Contractor's SA indicates acceptance for payment by credit card, that method may be used in conjunction with the following.	
	<input type="checkbox"/>	Single Payment
	<input type="checkbox"/>	Multiple Payment
6.	<b>Invoicing <i>(optional)</i></b>	
	Further to the Invoicing terms of the WTCM document, the Contractor will deliver the original and one copy of the invoice to the following address for certification and payment:	
	Name of the organization and contact: <i>[To be completed at contract award]</i>	
	Address:	
7.	<b>SACC Manual Clauses</b>	
	<input type="checkbox"/>	Not applicable

**ANNEX A  
REQUIREMENT and BASIS OF PAYMENT**

1. Category Selection

**Combined Categories Rule:**

For reasons of compatibility, the following categories will be combined for evaluation and contract award purposes:

The rule only applies to the categories below that are checked. The unchecked categories will be evaluated separately and may be awarded to multiple suppliers;

*(IU must identify which of the following categories will be combined for reasons of compatibility)*

- Category 1**
- Category 2**
- Category 5**

**\* Exception: when using the Cat 1, 2, 5 combined categories rule, IU's may calculate the percentage of NSA product allowed (as defined in their solicitation document) against the total quantity of the combined categories.**

**Design Upgrade Rule:**

The IU may exercise an option to upgrade products up to 20% of each Category product total before Applicable Taxes after contract award.

The Design Upgrade amount is used at the discretion of the Project Authority (PA) **prior to the manufacturing/ordering of the products**, the PA will provide the Contractor with a written notice of Canada's Design Upgrade choices for each of the product(s) to be upgraded. The Contractor will provide the pricing of the upgraded product(s) to a maximum of 20% of each Category Contract Price of Table 8. The Contracting Authority will issue an amendment to the contract with the Design Upgrades and pricing.

The Supplier certifies that all the Design Upgraded products offered will conform to all specifications and meet the testing requirements detailed in the Specifications of the Supply Arrangement.

Design Upgrade: is the process of replacing a product with a more innovative or enhanced version of the same product.

**NSA:**

NSA products can be incorporated in the RFB and must not exceed 30% of the firm quantity by category. NSA items must be added to the category that is most closely related and must be generic.

The requirement includes the following category (ies) of work (es):

a. Category 1 – Interconnecting Panels and Freestanding Systems

Category 1a – Interconnecting Panels (Refer to Annex C)

Category 1b – Supporting components and freestanding furniture

**RULE:** Metal Storage

Identified Users may procure metal storage products forming part of Category 1 when the metal storage products will be part of a requirement for a workstation(s)/work point(s). If this rule does not apply, Category 3 must be used for the metal storage products forming part of this category.

b.  Category 2 – Freestanding Height Adjustable Desk / Table Products

c.  Category 3 – Metal Filing and Storage Cabinets

Identifying the maximum height of the Personal Storage Towers, Wardrobes and Storage Cabinets is acceptable as per 6B. 4.1 of the SA (table 1 Additional product details)

d.  Category 4 – Wood Veneer – Freestanding Products

e.  Category 5 – Ancillary and Lighting Products

f.  Category 6 - Support Space – Collaborative Furniture

**RULE:** Category 6 can be further subdivided by space or like product in order to increase or allow competition. Space is defined as a location available for a particular purpose such as a meeting room space or a collaborative space. Like products are defined as products with similar design and construction. If NSA products form part of the requirement, the IU must validate the 30% NSA prior to subdividing the category. NSA products can be added to any subdivide or in its own subdivide.

The IU must identify how Category 6 will be subdivided in the Product Table for Category 6.

g.  NSA Product(s) – Category(ies): \_\_\_\_\_

## 2. Product and Pricing Tables

**Site Inspection Date:** To be coordinated with Project Authority after contract award. (Refer to Annex A article 4 of the SA for Site Inspection and Documentation instructions.)

**INSTRUCTIONS TO BIDDERS:** Bidders are to complete Sections B of the tables identified by the IU in this article as well as Tables 8 and 9. **Bidders must provide a complete product offering for each category, or CAT 6 sub-divide they wish to submit a bid in order to be compliant.**

**\*\*Refer to article 6A.7 for instructions on how to submit products that are not approved in product listing.\*\***

In a resulting contract, the term “Bid” means the Supplier’s commitment, the term “Bidder” means “Contractor”.

Product Category: 3

Table 1 – Product Table

Section A - IU REQUIREMENT				Section B – SUPPLIER'S BID			
#	GoCUID	Description of Product <i>(Additional product details may be inserted, if required as per 6B. 4.1 of the SA)</i>	QTY	** Provide additional Information Yes/No	Supplier Part Number	Firm Unit Price \$	Extended Total [Qty x Price] \$
1	3LSL1HXXLM18D20XHXS	<ul style="list-style-type: none"> <li>Elevated Single Locker with Solid Back and Full Left Swing Doors</li> <li>51"h, 20"d, 18"w.</li> <li>One adjustable shelf in top with double hook</li> <li>Built-in digital lock with integrated handle</li> <li>Integrated Interpret handles.</li> </ul>	120	Yes		\$	\$
2	Component	KEY-NM-PRG-00-01 <b>Programming Key</b>	2	Yes		\$	\$
3	Component	CLÉ-NM-MGR-00-01. <b>Manager Key</b>	2	Yes		\$	\$
					Product Total		\$

\*\*Provide additional information:

Canada is requesting bidders: to provide drawings and/or pictures including descriptive literature for these products with your bid submission.

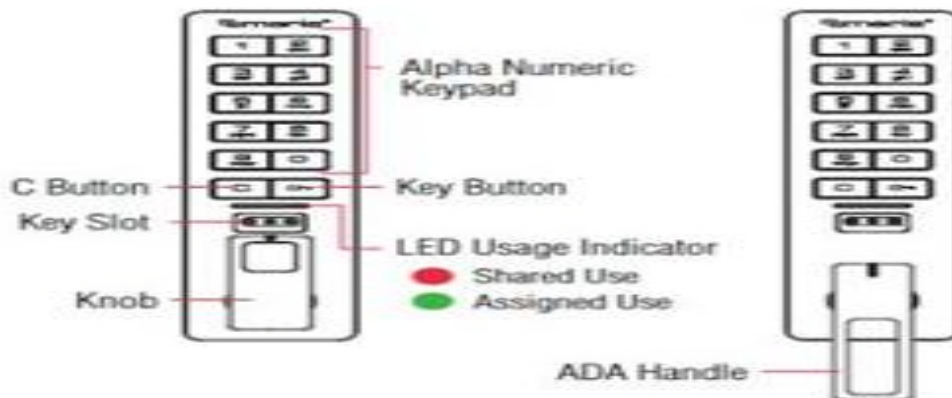

Vertical with Knob on Bottom

# Locker specifications

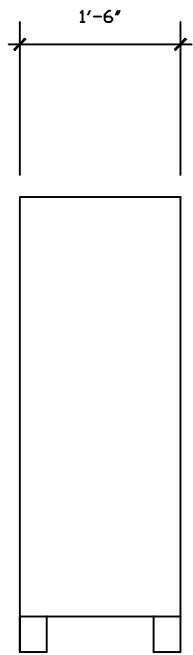

Side

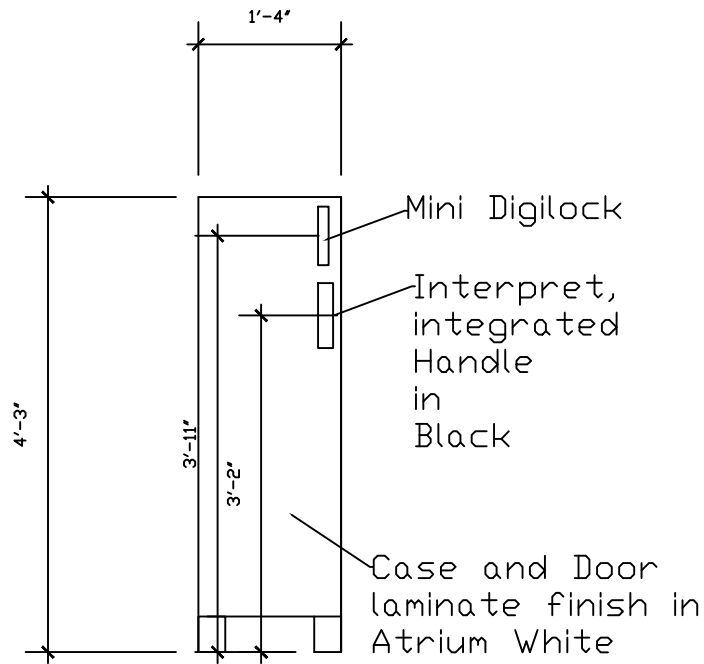

Front

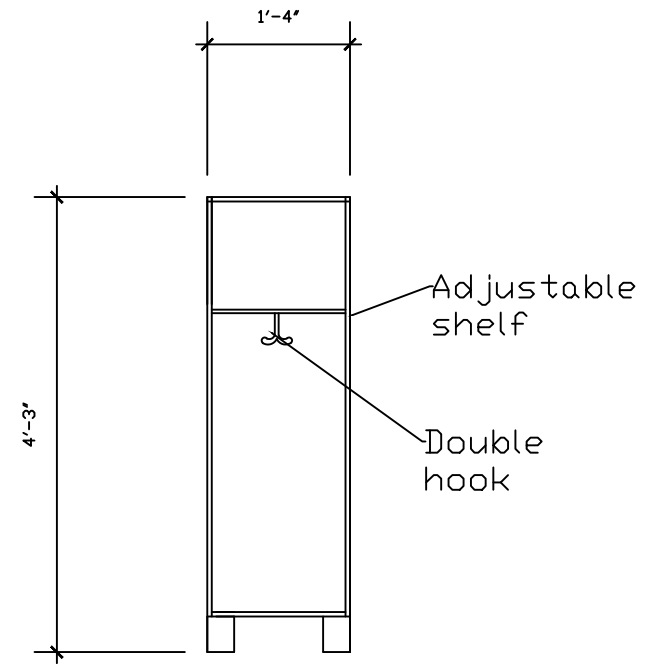

Inside



Table 2 - Delivery

Section A - IU REQUIREMENT				Section B – SUPPLIER'S BID	
Product Item # from Table 1	Location	Desired Date** (Y/M/D)	Desired Time: Normal Business Hours Or Outside Normal Business Hours *	Supplier will supply and deliver as per below**	Firm Lot Price \$
1	Environment and Climate Change Canada  <b>Fontaine</b> 200 Sacré-Cœur Gatineau (Québec) J8X 4C6  Floor : <b>03</b>	2021/10/30  Quantity : <b>54</b>	Normal Business Hours	_____ : weeks  <i>Standard Lead time is between 6-10 weeks for furniture delivery and installation.</i>	\$
2	Environment and Climate Change Canada  <b>Place Vincent Massey (PVM)</b> 351 Boul. St-Joseph Gatineau (Québec) J8Y 3Z5  Floor : <b>18</b>	2021/10/30  Quantity : <b>66</b>	Normal Business Hours	_ : weeks  <i>Standard Lead time is between 6-10 weeks for furniture delivery and installation.</i>	\$
*Normal Business Hours 8:00 – 17:00, as per SA, Annex A, article 5  **The Project Authority (PA) will provide the supplier the authority to proceed prior to the finalized delivery date taking into consideration the delivery time provided by the supplier. Canada will not be responsible if the supplier chooses to proceed without the PA authorization.				Delivery Total:	\$

Table 3 – Installation

Section A - IU REQUIREMENT				Section B – SUPPLIER’S BID	
Product Item # from Table 1	Location	Desired Date** (Y/M/D)	Desired Time: Normal Business Hours Or Outside Normal Business Hours *	Supplier will install as per below**	Firm Lot Price \$
1	Environment and Climate Change Canada  <b>Fontaine</b> 200 Sacré-Cœur Gatineau (Québec) J8X 4C6  Floor : <b>03</b>	2021/10/30  Quantity : <b>54</b>	Normal Business Hours	_____ : weeks from date of supply and delivery  <i>Standard Lead time is between 6-10 weeks for furniture delivery and installation.</i>	\$
2	Environment and Climate Change Canada  <b>Place Vincent Massey (PVM)</b> 351 Boul. St-Joseph Gatineau (Québec) J8Y 3Z5  Floor : <b>18</b>	2021/10/30  Quantity : <b>66</b>	Normal Business Hours	_____ : weeks from date of supply and delivery  <i>Standard Lead time is between 6-10 weeks for furniture delivery and installation.</i>	\$
*Normal Business Hours 8:00 – 17:00, as per SA, Annex A, article 5  **The Project Authority (PA) will provide the supplier the authority to proceed prior to the finalized installation date taking into consideration the installation time provided by the supplier. Canada will not be responsible if the supplier chooses to proceed without the PA authorization.				Installation Total:	\$

Table 4 – Optional Product

Section A - IU REQUIREMENT				Section B – SUPPLIER'S BID			
#	GoCUID	Description of Product <i>(Additional product details may be inserted, if required as per 6B. 4.1 of the SA)</i>	QTY	** Provide additional Information Yes/No	Supplier Part Number	Firm Unit Price \$	Extended Total [Qty x Price] \$
1	3LSL1HXXLM18D20XHXS	<ul style="list-style-type: none"> <li>Elevated Single Locker with Solid Back and Full Left Swing Doors</li> <li>51"h, 20"d, 18"w.</li> <li>One adjustable shelf in top with double hook</li> <li>Built-in digital lock with integrated handle</li> <li>Integrated Interpret handles.</li> </ul> 	110	Yes		\$	\$
2	Component	KEY-NM-PRG-00-01 <b>Programming Key</b>	3	Yes		\$	\$
3	Component	KEY-NM-MGR-00-01. <b>Manager Key</b>	3	Yes		\$	\$
						Product Total	\$
<b>**Provide additional information:</b> Canada is requesting bidders: to provide drawings and/or pictures including descriptive literature for these products with your bid submission.							

Table 5 – Optional Delivery

Section A - IU REQUIREMENT				Section B – SUPPLIER'S BID	
Product Item # from Table 1	Location	Desired Date** (Y/M/D)	Desired Time: Normal Business Hours Or Outside Normal Business Hours *	Supplier will supply and deliver as per below**	Firm Lot Price \$
1	Environment and Climate Change Canada  <b>Fontaine</b> 200 Sacré-Cœur Gatineau (Québec) J8X 4C6  Floor : <b>To be determinate (TBD)</b>	Date : TBD  On or before 31 marsh 2022  Quantity : TBD	Normal Business Hours	_____ : weeks  <i>Standard Lead time is between 6-10 weeks for furniture delivery and installation.</i>	\$
2	Environment and Climate Change Canada  <b>Place Vincent Massey (PVM)</b> 351 Boul. St-Joseph Gatineau (Québec) J8Y 3Z5  Floor : <b>To be determinate (TBD)</b>	Date : TBD  On or before 31 marsh 2022  Quantity : TBD	Normal Business Hours	_ : weeks  <i>Standard Lead time is between 6-10 weeks for furniture delivery and installation.</i>	\$
*Normal Business Hours 8:00 – 17:00, as per SA, Annex A, article 5  **The Project Authority (PA) will provide the supplier the authority to proceed prior to the finalized delivery date taking into consideration the delivery time provided by the supplier. Canada will not be responsible if the supplier chooses to proceed without the PA authorization.				Delivery Total:	\$

Table 6 – Optional Installation

Section A - IU REQUIREMENT				Section B – SUPPLIER'S BID	
Product Item # from Table 1	Location	Desired Date** (Y/M/D)	Desired Time: Normal Business Hours Or Outside Normal Business Hours *	Supplier will install as per below**	Firm Lot Price \$
1	Environment and Climate Change Canada  <b>Fontaine</b> 200 Sacré-Cœur Gatineau (Québec) J8X 4C6  Floor : <b>To be determinate (TBD)</b>	Date : TBD  On or before 31 marsh 2022  Quantity : TBD	Normal Business Hours	_____ : weeks from date of supply and delivery  <i>Standard Lead time is between 6-10 weeks for furniture delivery and installation.</i>	\$
2	Environment and Climate Change Canada  <b>Place Vincent Massey (PVM)</b> 351 Boul. St-Joseph Gatineau (Québec) J8Y 3Z5  Floor : <b>To be determinate (TBD)</b>	Date : TBD  On or before 31 marsh 2022  Quantity : TBD	Normal Business Hours	_____ : weeks from date of supply and delivery  <i>Standard Lead time is between 6-10 weeks for furniture delivery and installation.</i>	\$
*Normal Business Hours 8:00 – 17:00, as per SA, Annex A, article 5  **The Project Authority (PA) will provide the supplier the authority to proceed prior to the finalized installation date taking into consideration the installation time provided by the supplier. Canada will not be responsible if the supplier chooses to proceed without the PA authorization.				Installation Total:	\$

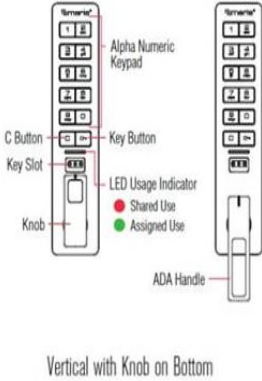
Table 7 – Standard Finishes and Canada's Facilities to Accommodate the Delivery and Certifications

<b>1.</b>	<b>Standard Finishes</b>	
1.1	IU is to consult the Supplier's Website identified in Part 6A of the SA to view the available finishes.  Within ten business days of the contract award, the Project Authority will provide the Contractor with a written notice of Canada's finish choices for each of the product(s) in Annex A.  The Contractor will deliver the products corresponding to Canada's choice of specific finishes(s). No additional charge will be applied to Canada.	
<b>2.</b>	<b>Canada's Facilities to Accommodate the Delivery</b> <i>The Supplier's employees and subcontractors requiring access to the site must adhere to the health and safety plans established for the site, in addition to any laws in effect in the jurisdiction where the work is being performed.</i>  <i>During the period of the contract, a representative of Canada or a service provider(s) under contract with the Government of Canada may request the list of employees and subcontractors requiring access to the site to perform the work and their security statuses. Information must be provided in the timeframe prescribed in order to ensure that the supply, delivery and installation of the furniture aligns with the master schedule.</i>	
2.1	Loading Dock/Location	
A	Location	<b>Fontaine</b> 200 Sacré-Cœur Gatineau (Québec) J8X 4C6
		<b>Place Vincent Massey (PVM)</b> 351 Boul. St-Joseph Gatineau (Québec) J8Y 3Z5

B	Dock	Yes
C	Lift	Yes
D	Door	41 inches W and et 82 inches H
E	Freight Elevator	Non
F	Other (specify, if any)	
<b>3.</b>	<b>Continuance of Certifications</b>	
	The Bidder certifies that by submitting a bid in response to the RFB, the Bidder, and any of the Bidder's members if the Bidder is a Joint Venture, continues to comply with all of the following certifications listed in Parts 6A and 6B of the Bidder's SA for Work Spaces.	
	Canada may request copies of environmental certification(s) prior to contract award within a time period specified by the Identified User.	
3.1	Integrity Provisions	
3.2	Federal Contractor's Program for Employment Equity	
3.4	Product Conformance	
3.5	Price Certification (In accordance with the SA, Part 6B)	

**Table 8 - Bid Evaluation and Contract Total (Canada may complete if not completed by the Bidder)**

1	<b>Firm Product Total (Table 1)</b>	\$
2	<b>Firm Delivery Total (Table 2)</b>	\$
3	<b>Firm Installation Total (Table 3)</b>	\$
4	<b>Optional Product Total (Table 4) (Applicable if Option is exercised)</b>	\$
5	<b>Optional Delivery Total (Table 5) (Applicable if Option is exercised)</b>	\$
6	<b>Optional Installation Total (Table 6) (Applicable if Option is exercised)</b>	\$
7	Hardware Total as per article 1.5 of Annex A-1 of SA (if Applicable)	\$
8	<b>Total Evaluated (Bid) Price* (1 + 2 + 3 + 4 + 5 + 6+ 7) [to be removed at contract award]</b>	\$
9	<b>Contract Price(1+2+3+7): [applicable at contract award only]</b>	\$
10	<b>Applicable Tax(es): [applicable at contract award only]</b>	\$
11	<b>Total Estimated Cost (9+10): [applicable at contract award only]</b>	\$

\* Applicable taxes extra.

**Table 9 – Bidder's Authorized Representative**

1.	<b>Bidder's Authorized Representative for the Bid and the Contract</b>		
	Name:	Telephone:	
		E-Mail:	
		PBN:	