

BACKGROUND:

- SOUTH OF THE POOL AREA IS AN EXIST. MASS RET. WALL CONSTRUCTED FROM STONE MASONRY. REFER TO DET. 1/S1.
- THE SHORT STRAIGHT NORTH-SOUTH LEG IS APPROX. 4 M LG.. THE LONGER CURVILINEAR LEG IS APPROX. 19 M LG.. THE HEIGHT VARIES B/W 0.7 M & 3.1 M. REFER TO DET'S 1/S5 TO 1/S7.
- IN RECENT YEARS, PARKS CANADA USED THE UPPER GRADE AS A SNOW STORAGE AREA, WHICH INCREASED THE OVERBURDEN & THE HYDROSTATIC PRESS. ON THE WALL.
- THE INCREASE IN LAT'L LOAD CAUSED DAMAGE TO THE WALL, WHICH REQUIRES REMEDIATION. REFER TO DET'S 5/S2 & 6/S2.
- AS A HERITAGE SITE, PARKS CANADA IS REQUIRED TO MAINTAIN THE 'FABRIC' (OR OUTWARD APPEARANCE) OF THE WALL. AND AS SUCH, REBUILDING THE STONE MASONRY SHALL BE MINIMIZED.

OVERALL SCOPE OF WORK:

1

1. REMOVE ALL ASPHALT PAVEMENT IN THE IMMEDIATE AREA. REMOVE THE STONE PLANTER. REMOVE THE EXIST. STORMWATER DRAIN. REFER TO DET. 1/S3 (DEMOLITION PLAN).
2. EXCAVATE DOWN THE INSIDE FACE TO THE BASE OF THE STONE WALL.
3. REPOINT THE INSIDE FACE OF THE THE DAMAGED PORTION OF THE STONE WALL.
4. INSTALL A NEW C.I.P. CONC. RET. WALL ALONG THE INSIDE FACE OF THE STONE WALL. THE CONC. WALL WILL BE CAST IN 4 POURS (STRIP FTG., WALL, CANT. SLAB & CURB).
5. REPAIR THE OUTSIDE FACE OF THE DAMAGED PORTION OF THE STONE WALL.
6. INSTALL RIGID INSUL. & A DRAINAGE SYSTEM ALONG THE INSIDE FACE OF THE NEW CONC. WALL.
7. INSTALL A NEW PLANTER W/ A C.I.P. CONC. BASE & RUNDLE STONE MASONRY WALLS. (THE PLANTER WALLS SHALL MATCH THE RET. WALL).
8. INSTALL A NEW STORMWATER DRAIN.
9. INSTALL NEW ASPHALT PAVEMENT.
10. REMOVE ALL LOOSE STONES & LOOSE MORTAR FROM THE TOP OF THE STONE RET. WALL & REINSTALL ALL LOOSE STONE (APPROX. 25% OF THE STONE ALONG THE T.O. WALL).

NOTE: THE DAMAGED PORTION OF THE STONE WALL SHALL BE REPAIRED / REBUILT. THE EXTENT OF THE DAMAGE WILL BE BETTER UNDERSTOOD ONCE THE INSIDE FACE OF THE STONE WALL HAS BEEN EXCAVATED.

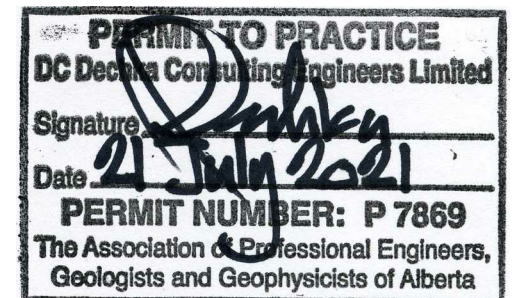
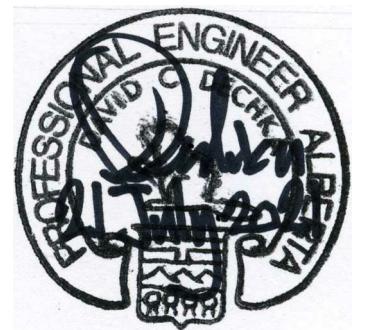

REV.	DESCRIPTION	DATE
1	POURS REVISED	27 JULY 2021
0	ISSUED FOR TENDER	21 JULY 2021

DC D.C. DECHKA CONSULTING ENGINEERS LIMITED
 27 Silverview Place N.W., Calgary, AB, T3B 3K5
 Phone: (403) 204 - 2234
 E-mail: dechka@telus.net

**PARKS CANADA - UPPER BANFF HOT SPRINGS
 STONE BLOCK RETAINING WALL UPGRADES**

KEY PLAN & OVERALL SCOPE OF WORK

PROJECT NUMBER:	21-153-01
DATE:	6 JULY 2021
SCALE:	AS SHOWN
DRAWN:	D.C.
CHECKED:	D.D.

DRAWING NUMBER:
S1



DET. 1/S2 - UPPER LEVEL OF CURVILINEAR LEG OF STONE RET. WALL (LOOKING SOUTH).



DET. 2/S2 - NORTHERN '3RD' OF CURVILINEAR LEG OF STONE RET. WALL (LOOKING WEST).



DET. 3/S2 - MIDDLE '3RD' OF CURVILINEAR LEG OF STONE RET. WALL (LOOKING NORTHWEST).



DET. 4/S2 - WESTERN '3RD' OF CURVILINEAR LEG OF STONE RET. WALL (LOOKING WEST).



DET. 5/S2 - NORTHERN '3RD' OF CURVILINEAR LEG OF STONE RET. WALL (LOOKING SOUTHWEST). DASHED LINE SHOWS 'BULGE' IN STONE RET. WALL, INDICATIVE OF OVERLOAD.



DET. 6/S2 - PORTION OF CURVILINEAR LEG OF STONE RET. WALL. DASHED LINE SHOWS 'BULGE' IN STONE RET. WALL, INDICATIVE OF OVERLOAD.

REV.	DESCRIPTION	DATE
0	ISSUED FOR TENDER	21 JULY 2021

D.C. DECHKA CONSULTING ENGINEERS LIMITED
 27 Silverview Place N.W., Calgary, AB, T3B 3K5
 Phone: (403) 204 - 2234
 E-mail: dechka@telus.net

PARKS CANADA - UPPER BANFF HOT SPRINGS
STONE BLOCK RETAINING WALL UPGRADES

EXISTING STONE RETAINING WALL

PROJECT NUMBER:	21-153-01
DATE:	6 JULY 2021
SCALE:	AS SHOWN
DRAWN:	D.C.
CHECKED:	D.D.

DRAWING NUMBER:

S2

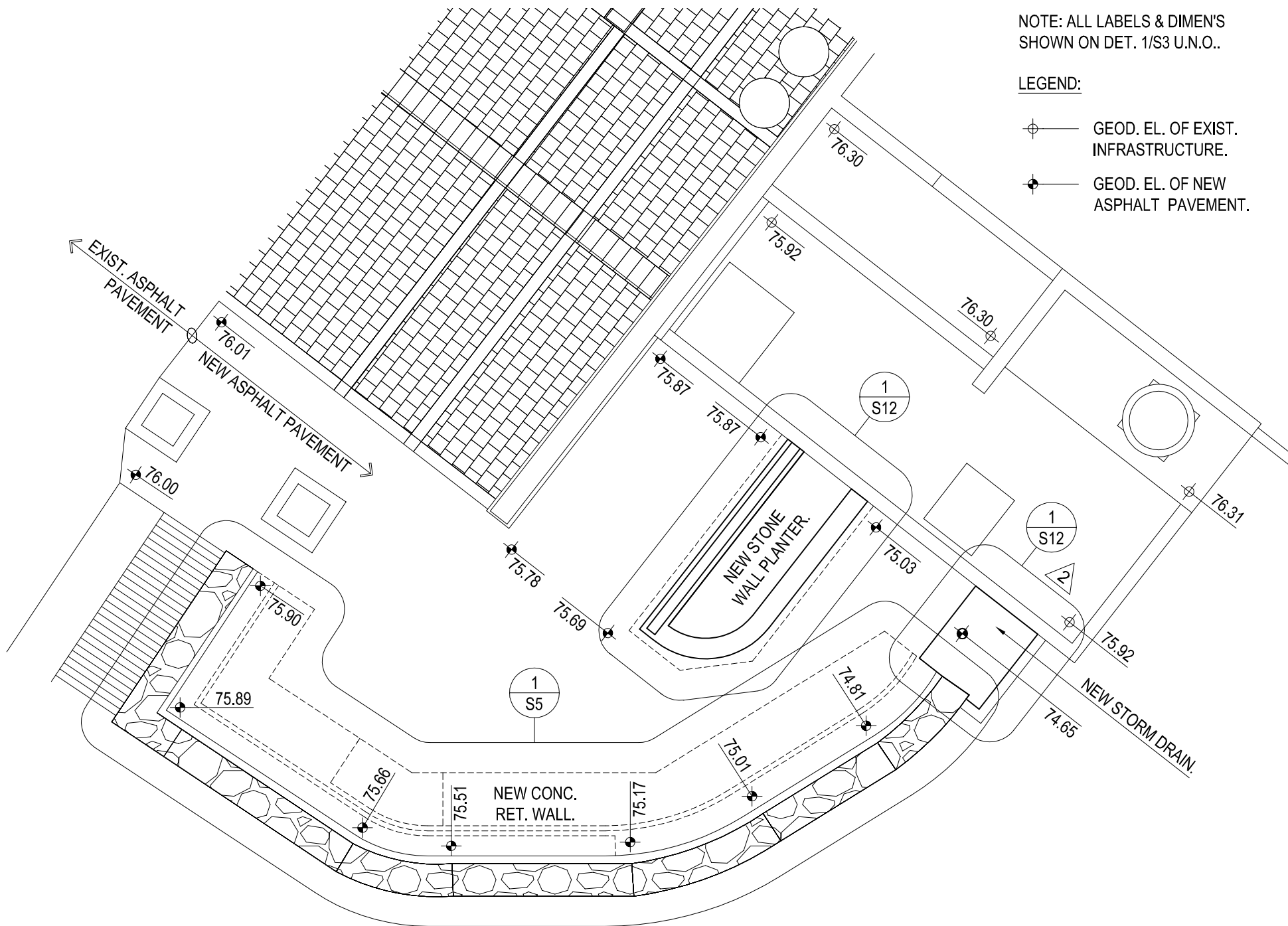

NOTE: ALL LABELS & DIMEN'S SHOWN ON DET. 1/S3 U.N.O..

LEGEND:

- ⊕ GEOD. EL. OF EXIST. INFRASTRUCTURE.
- ⊕ GEOD. EL. OF NEW ASPHALT PAVEMENT.

SCOPE OF NEW WORK:

1. EXCAVATE DOWN THE INSIDE FACE TO THE BASE OF THE STONE WALL. EXCAVATE FOR CONC. BASE OF NEW STONE WALL PLANTER.
2. DAMAGE TO EXIST. STONE RET. WALL ALONG I.F. OF WALL SHALL BE REVIEWED BY STRUC. ENG'R, @ WHICH TIME STRUC. ENG'R WILL DETERMINE THE EXTENT THE STONE BLOCK TO BE REPOINTED FROM I.F.. REFER TO DET. 1/S15.
3. INSTALL NEW C.I.P. CONC. RET. WALL ALONG THE I.F. OF STONE WALL. THE CONC. WALL WILL BE CAST IN 4 POURS (STRIP FTG., WALL, CANT. SLAB & CURB). REFER TO DET'S 1/S5 TO 1/S7.
4. INSTALL RIGID INSUL. & WEeping TILE ALONG I.F. OF NEW CONC. WALL. WEeping TILE SHALL DAYLIGHT @ N. END OF EXIST. STONE WALL. (THRU EXIST. CONC. FDN. WALL).
5. INSTALL NEW PLANTER (W/ A C.I.P. CONC. BASE & RUNDLE STONE MASONRY WALLS). PLANTER WALLS SHALL MATCH RET. WALL. REFER TO DET. 1/S12.
6. INSTALL NEW STORMWATER DRAIN. CONN. NEW DRAIN TO EXIST. DISCHARGE LINE. REFER TO DET. 1/S12.
7. B/FILL NEW RET. WALL AS SHOWN ON DET'S 1/S7 TO 1/S11.
8. INSTALL NEW ASPHALT PAVEMENT. REFER TO GEN. NOTES FOR TYPE OF ASPHALT & TYPE OF GRAVEL BASE. REFER TO DET. 1/S5 FOR T.O. PAVEMENT EL'S.
9. REPAIR DAMAGE TO EXIST. STONE RET. WALL ALONG O.F. OF WALL. REFER TO DET. 1/S15.
10. REMOVE ALL LOOSE STONES & LOOSE MORTAR FROM T.O. STONE RET. WALL & REINSTALL LOOSE STONE (APPROX. 25% OF STONE ALONG T.O. WALL).

1 PARTIAL PLAN @ EXIST. STONE RET. WALL SHOWING NEW WORK.
S4 SCALE - 1 : 100

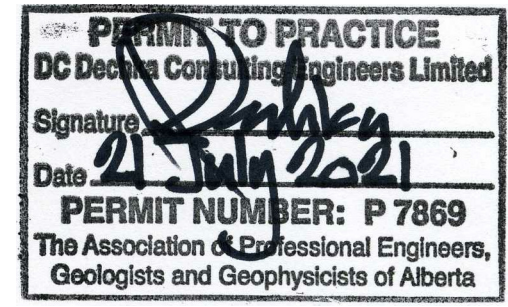
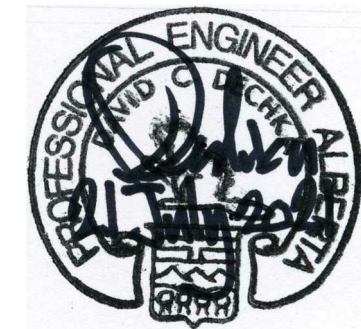

REV.	DESCRIPTION	DATE
2	SIZE OF STORM DRAIN SLAB INCREASED	13 SEPT. 2021
1	POURS REVISED	27 JULY 2021
0	ISSUED FOR TENDER	21 JULY 2021

DC D.C. DECHKA CONSULTING ENGINEERS LIMITED
 27 Silverview Place N.W., Calgary, AB, T3B 3K5
 Phone: (403) 204 - 2234
 E-mail: dechka@telus.net

PARKS CANADA - UPPER BANFF HOT SPRINGS
 STONE BLOCK RETAINING WALL UPGRADES

NEW WORK PLAN

PROJECT NUMBER:	21-153-01
DATE:	6 JULY 2021
SCALE:	AS SHOWN
DRAWN:	D.C.
CHECKED:	D.D.

DRAWING NUMBER:
S4

1 PARTIAL PLAN OF NEW CONC. RET. WALL.
 S5 SCALE - 1 : 60

NOTES:

1. ALL DIMEN'S ARE APPROX..
2. PRIOR TO PROCEEDING WITH THE WORK, THE CONTRACTOR SHALL REVIEW THE CONTRACT DWG'S, REPORT ANY DISCREPANCIES &/OR DEFICIENCIES TO THE STRUC. ENGR, & THEN WAIT FOR FURTHER INSTRUCTIONS.

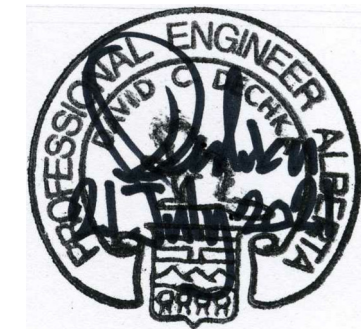
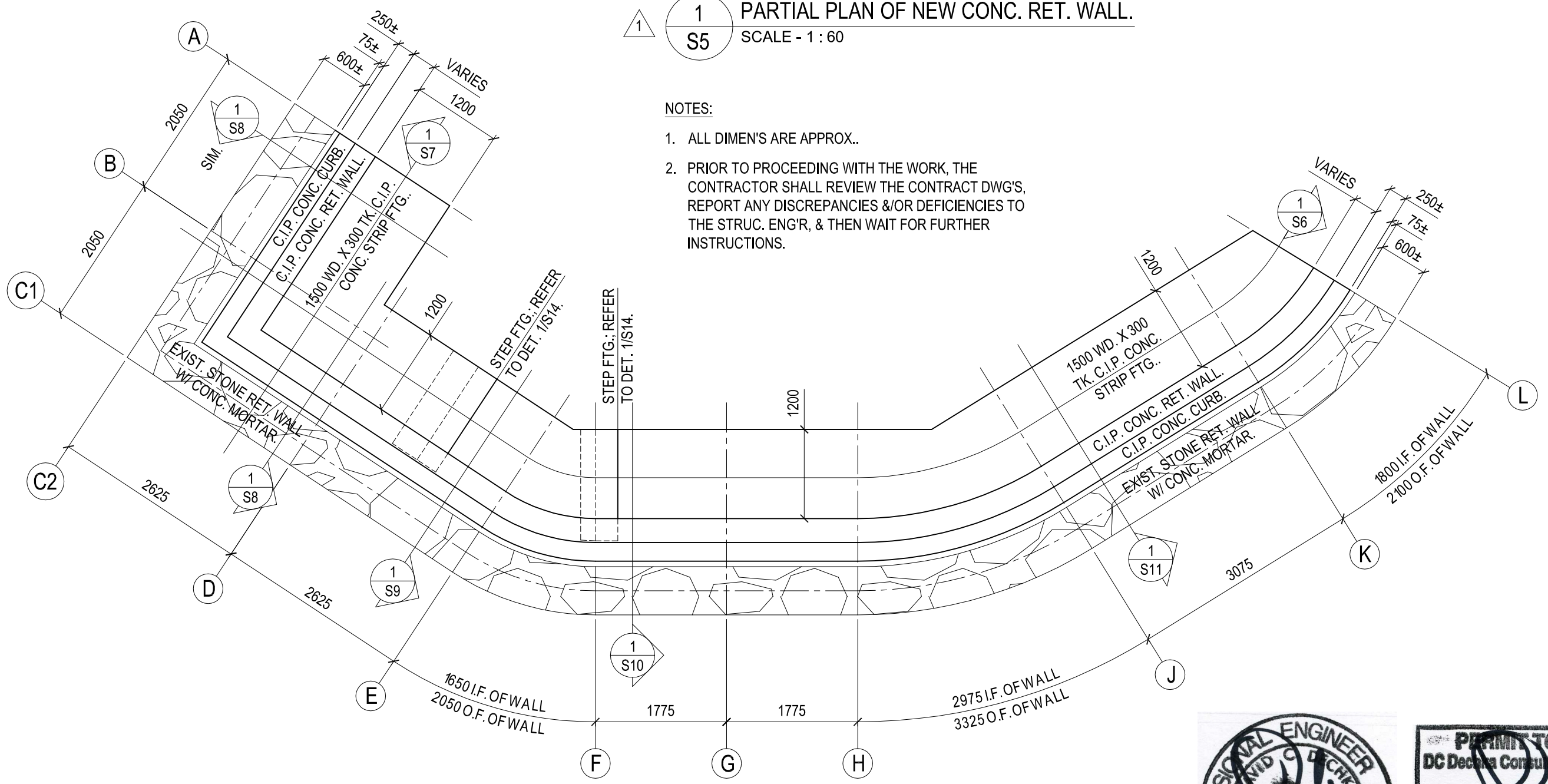

PERMIT TO PRACTICE
 DC Dechka Consulting Engineers Limited
 Signature: *[Signature]*
 Date: 21 July 2021
PERMIT NUMBER: P 7869
 The Association of Professional Engineers,
 Geologists and Geophysicists of Alberta

REV.	DESCRIPTION	DATE
1	GENERAL REVISIONS	27 JULY 2021
0	ISSUED FOR TENDER	21 JULY 2021

DC D.C. DECHKA CONSULTING ENGINEERS LIMITED
 27 Silverview Place N.W., Calgary, AB, T3B 3K5
 Phone: (403) 204 - 2234
 E-mail: dechka@telus.net

PARKS CANADA - UPPER BANFF HOT SPRINGS
 STONE BLOCK RETAINING WALL UPGRADES

PLAN

PROJECT NUMBER:	21-153-01
DATE:	6 JULY 2021
SCALE:	AS SHOWN
DRAWN:	D.C.
CHECKED:	D.D.

DRAWING NUMBER:
S5

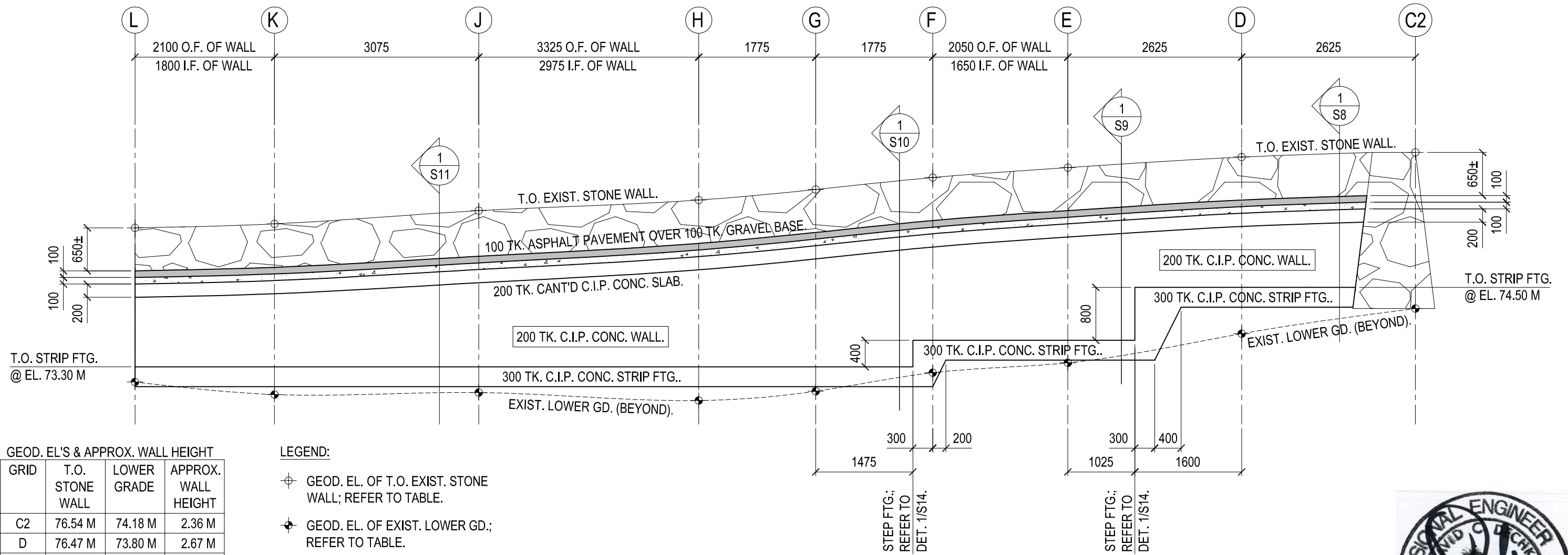

GEOD. EL'S & APPROX. WALL HEIGHT

GRID	T.O. STONE WALL	LOWER GRADE	APPROX. WALL HEIGHT
C2	76.54 M	74.18 M	2.36 M
D	76.47 M	73.80 M	2.67 M
E	76.31 M	73.36 M	2.95 M
F	76.16 M	73.21 M	2.95 M
G	75.98 M	72.93 M	3.05 M
H	75.82 M	72.79 M	3.03 M
J	75.66 M	72.91 M	2.75 M
K	75.46 M	72.88 M	2.58 M
L	75.40 M	73.07 M	2.33 M

LEGEND:

- ⊕ GEOD. EL. OF T.O. EXIST. STONE WALL; REFER TO TABLE.
- ⊕ GEOD. EL. OF EXIST. LOWER GD.; REFER TO TABLE.

NOTES:

1. ALL DIMEN'S ARE APPROX..
2. PRIOR TO PROCEEDING WITH THE WORK, THE CONTRACTOR SHALL REVIEW THE CONTRACT DWG'S, REPORT ANY DISCREPANCIES &/OR DEFICIENCIES TO THE STRUC. ENG'R, & THEN WAIT FOR FURTHER INSTRUCTIONS.
3. CONC. CURB (ALONG I.F. OF STONE RET. WALL) NOT SHOWN FOR CLARITY; REFER TO DET'S 1/S8 TO 1/S11
4. FOR T.O. PAVEMENT EL'S ALONG I.F. OF STONE WALL REFER TO DET. 1/S4.

1 S6 ELEV. SHOWING NEW CONC. RET. WALL.
SCALE - 1 : 60

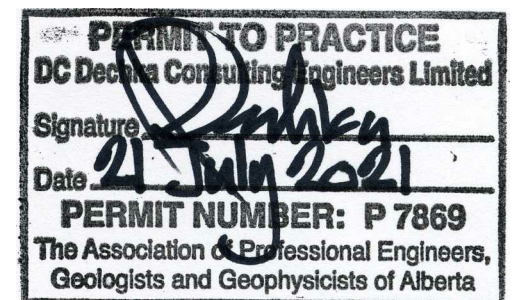
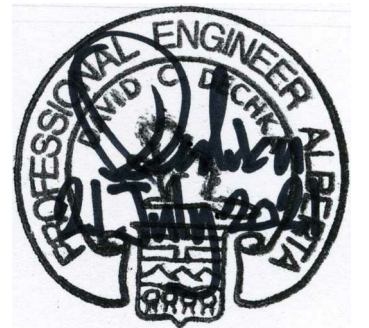

REV.	DESCRIPTION	DATE
1	GENERAL REVISIONS	27 JULY 2021
0	ISSUED FOR TENDER	21 JULY 2021

DC D.C. DECHKA CONSULTING ENGINEERS LIMITED
27 Silverview Place N.W., Calgary, AB, T3B 3K5
Phone: (403) 204 - 2234
E-mail: dechka@telus.net

**PARKS CANADA - UPPER BANFF HOT SPRINGS
STONE BLOCK RETAINING WALL UPGRADES**

ELEVATION

PROJECT NUMBER:	21-153-01
DATE:	6 JULY 2021
SCALE:	AS SHOWN
DRAWN:	D.C.
CHECKED:	D.D.

DRAWING NUMBER:
S6

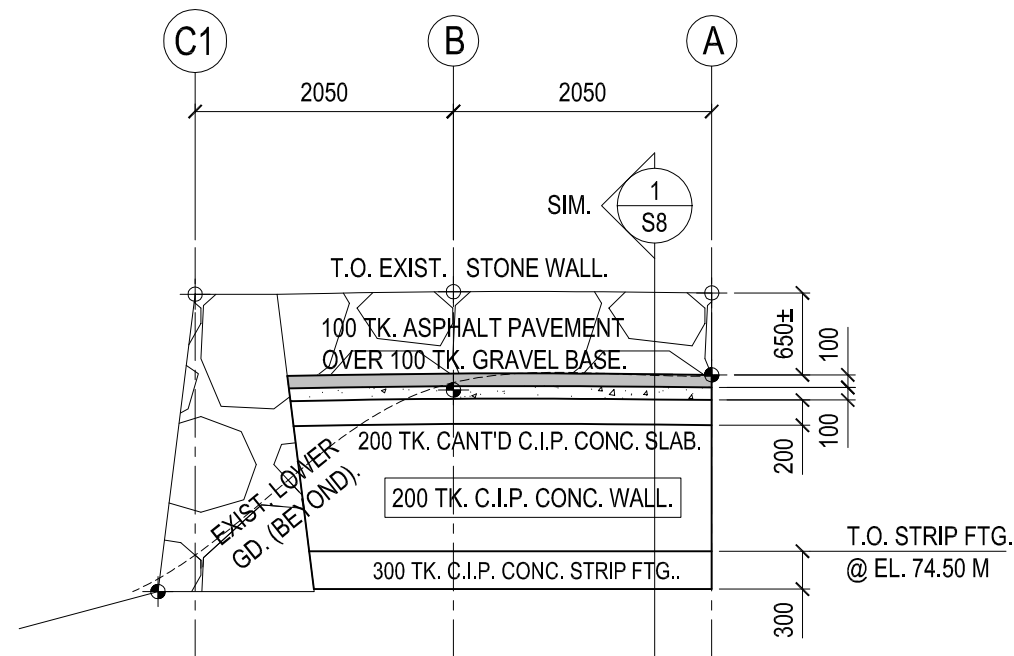

LEGEND:

- ⊕ GEOD. EL. OF T.O. EXIST. STONE WALL; REFER TO TABLE.
- ⊙ GEOD. EL. OF EXIST. LOWER GD.; REFER TO TABLE.

GEOD. EL'S & APPROX. WALL HEIGHT

GRID	T.O. STONE WALL	LOWER GRADE	APPROX. WALL HEIGHT
A	76.55 M	75.89 M	0.66 M
B	76.56 M	75.78 M	0.78 M
C1	76.54 M	74.18 M	2.36 M

1
S7 **ELEV. SHOWING NEW CONC. RET. WALL.**
SCALE - 1 : 60

NOTES:

1. ALL DIMEN'S ARE APPROX..
2. PRIOR TO PROCEEDING WITH THE WORK, THE CONTRACTOR SHALL REVIEW THE CONTRACT DWG'S, REPORT ANY DISCREPANCIES &/OR DEFICIENCIES TO THE STRUC. ENG'R, & THEN WAIT FOR FURTHER INSTRUCTIONS.
3. CONC. CURB (ALONG I.F. OF STONE RET. WALL) NOT SHOWN FOR CLARITY; REFER TO DET. 1/S8.
4. FOR T.O. PAVEMENT EL'S ALONG I.F. OF STONE WALL REFER TO DET. 1/S4.

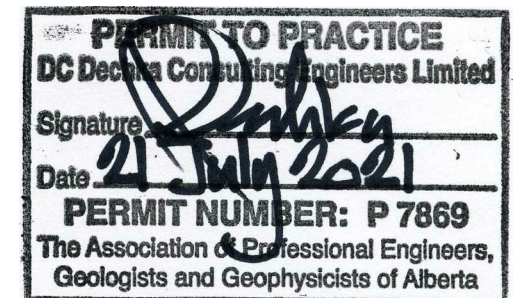
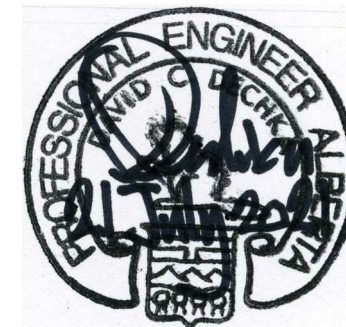

REV.	DESCRIPTION	DATE
1	GENERAL REVISIONS	27 JULY 2021
0	ISSUED FOR TENDER	21 JULY 2021

DC D.C. DECHKA CONSULTING ENGINEERS LIMITED
27 Silverview Place N.W., Calgary, AB, T3B 3K5
Phone: (403) 204 - 2234
E-mail: dechka@telus.net

**PARKS CANADA - UPPER BANFF HOT SPRINGS
STONE BLOCK RETAINING WALL UPGRADES**

ELEVATION

PROJECT NUMBER:	21-153-01
DATE:	6 JULY 2021
SCALE:	AS SHOWN
DRAWN:	D.C.
CHECKED:	D.D.

DRAWING NUMBER:
S7

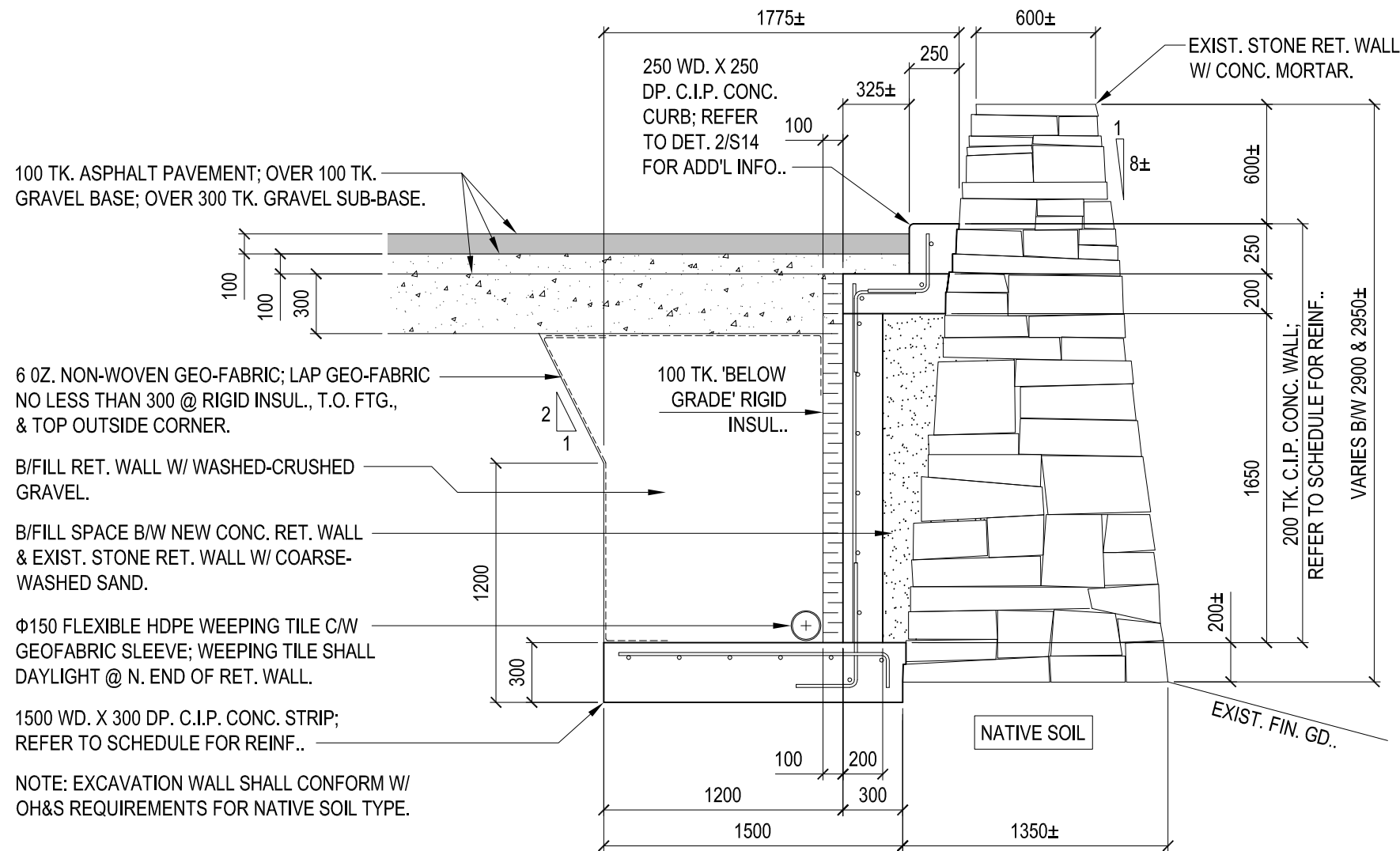

100 TK. ASPHALT PAVEMENT; OVER 100 TK. GRAVEL BASE; OVER 300 TK. GRAVEL SUB-BASE.

6 OZ. NON-WOVEN GEO-FABRIC; LAP GEO-FABRIC NO LESS THAN 300 @ RIGID INSUL., T.O. FTG., & TOP OUTSIDE CORNER.

B/FILL RET. WALL W/ WASHED-CRUSHED GRAVEL.

B/FILL SPACE B/W NEW CONC. RET. WALL & EXIST. STONE RET. WALL W/ COARSE-WASHED SAND.

Φ150 FLEXIBLE HDPE WEEPING TILE C/W GEOFABRIC SLEEVE; WEEPING TILE SHALL DAYLIGHT @ N. END OF RET. WALL.

1500 WD. X 300 DP. C.I.P. CONC. STRIP; REFER TO SCHEDULE FOR REINF..

NOTE: EXCAVATION WALL SHALL CONFORM W/ OH&S REQUIREMENTS FOR NATIVE SOIL TYPE.

1775±
250 WD. X 250 DP. C.I.P. CONC. CURB; REFER TO DET. 2/S14 FOR ADD'L INFO..

EXIST. STONE RET. WALL W/ CONC. MORTAR.

200 TK. C.I.P. CONC. WALL: REFER TO SCHEDULE FOR REINF..
VARIES BW 2900 & 2950±

NATIVE SOIL

EXIST. FIN. GD..

1 X-SECTION THRU. STONE RET. WALL. SCALE - 1 : 30

NOTES:

- AS-BUILT DIMEN'S OF EXIST. STONE RET. WALL ARE APPROX. & SHALL BE CONFIRMED BY CONTRACTOR.
- PRIOR TO PROCEEDING WITH THE WORK, THE CONTRACTOR SHALL REVIEW THE CONTRACT DWG'S, REPORT ANY DISCREPANCIES &/OR DEFICIENCIES TO THE STRUC. ENGR, & THEN WAIT FOR FURTHER INSTRUCTIONS.
- IN NEW CONC. WALL, CLR. CONC. COVER TO REINF. SHALL BE 50 MM.
- IN NEW CONC. FTG., CLR. CONC. COVER TO REINF. SHALL BE 50 MM @ TOP & 75 MM @ SIDES & BOT..
- FACTORS OF SAFETY INCLUDES CONTRIBUTION FROM EXIST. STONE RET. WALL; FS (SLIDING) = 2.2; FS (OVERTURNING) = 2.9.
- REFER TO GEN. NOTES FOR COMPACTION OF ASPHALT & GRAVEL.

SCHEDULE FOR STRIP FTG. REINF.

POUR	LONG'L REINF.	TRANSV. REINF.
FTG.	7 - 15M CONT.; 6 TOP (LL) & 1 CORNER BAR @ BOT. HK. OF 15M DWL'S (WALL)	15M (C/W 150 HK.) @ 200 O/C (UL)

SCHEDULE FOR WALL REINF.

POUR	HORIZ. REINF.	VERT. REINF.
WALL	15M CONT. @ 300 O/C	15M DWL'S (825 LG. W/ 300 HK.) @ 200 O/C BOT. (EMBED HK. 225 INTO FTG.); 15M @ 200 O/C
SLAB	2 - 15M CONT. (@ CORNERS OF DWL'S)	15M DWL'S (400 LG. W/ 300 HK.) @ 200 O/C (EMBED VERT. LEG 300 INTO WALL)
CURB	1 - 15M CONT.	15M DWL'S (300 LEGS) @ 400 O/C (EMBED HORIZ. LEG 100 INTO SLAB)

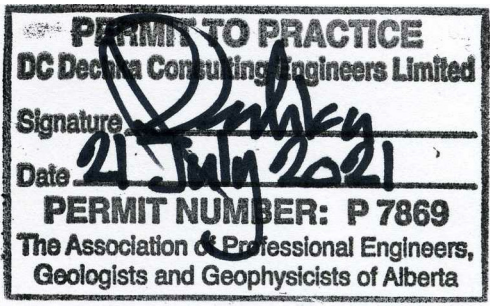
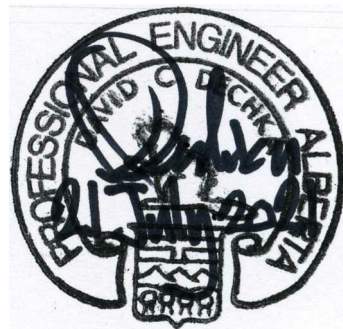

REV.	DESCRIPTION	DATE
1	GENERAL REVISIONS	27 JULY 2021
0	ISSUED FOR TENDER	21 JULY 2021

DC D.C. DECHKA CONSULTING ENGINEERS LIMITED
27 Silverview Place N.W., Calgary, AB, T3B 3K5
Phone: (403) 204 - 2234
E-mail: dechka@telus.net

PARKS CANADA - UPPER BANFF HOT SPRINGS
STONE BLOCK RETAINING WALL UPGRADES

CROSS-SECTION

PROJECT NUMBER:	21-153-01
DATE:	6 JULY 2021
SCALE:	AS SHOWN
DRAWN:	D.C.
CHECKED:	D.D.

DRAWING NUMBER:

S9

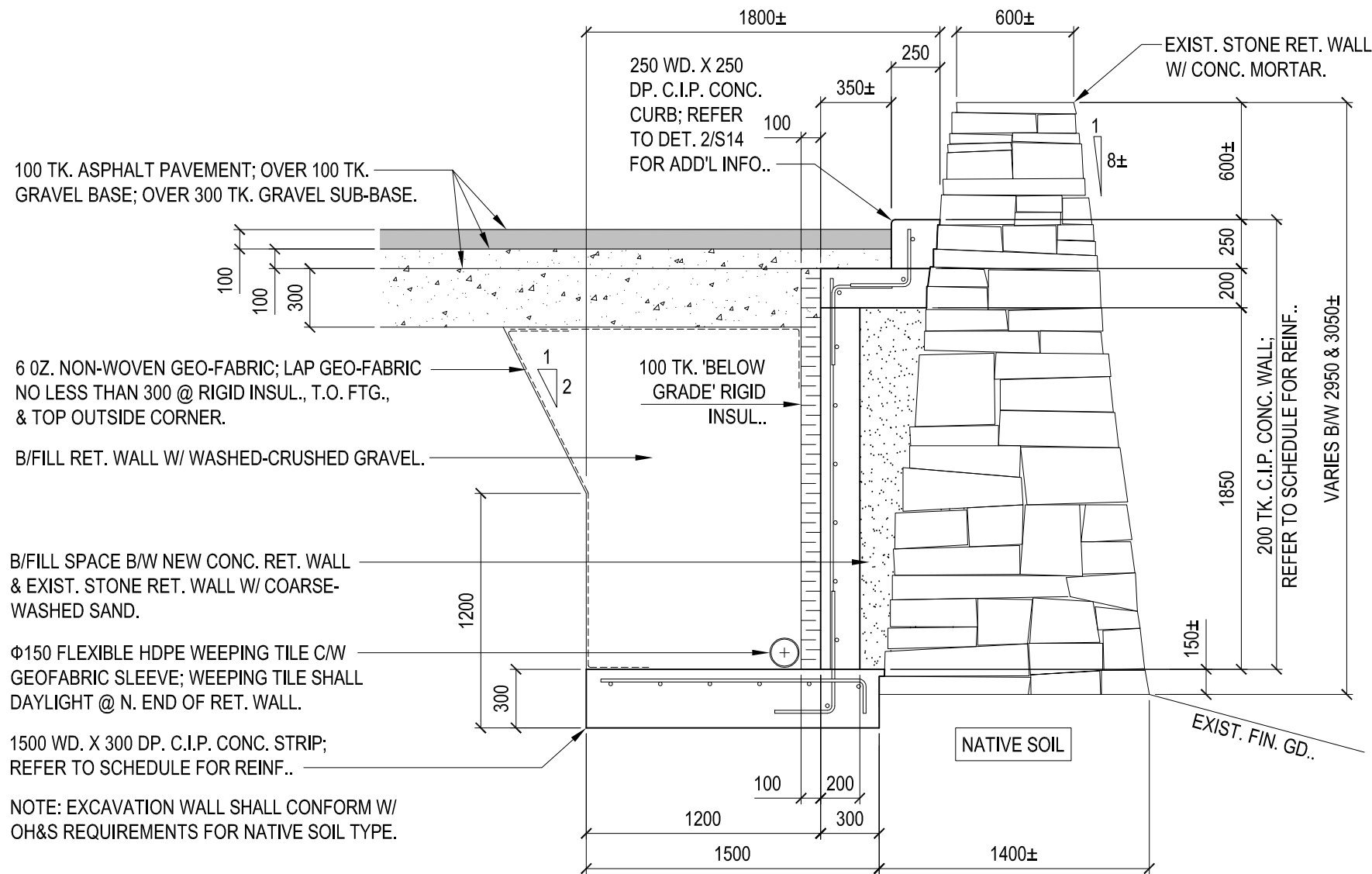

NOTES:

- AS-BUILT DIMEN'S OF EXIST. STONE RET. WALL ARE APPROX. & SHALL BE CONFIRMED BY CONTRACTOR.
- PRIOR TO PROCEEDING WITH THE WORK, THE CONTRACTOR SHALL REVIEW THE CONTRACT DWG'S, REPORT ANY DISCREPANCIES &/OR DEFICIENCIES TO THE STRUC. ENGR, & THEN WAIT FOR FURTHER INSTRUCTIONS.
- IN NEW CONC. WALL, CLR. CONC. COVER TO REINF. SHALL BE 50 MM.
- IN NEW CONC. FTG., CLR. CONC. COVER TO REINF. SHALL BE 50 MM @ TOP & 75 MM @ SIDES & BOT..
- FACTORS OF SAFETY INCLUDES CONTRIBUTION FROM EXIST. STONE RET. WALL; FS (SLIDING) = 2.0; FS (OVERTURNING) = 2.6.
- REFER TO GEN. NOTES FOR COMPACTION OF ASPHALT & GRAVEL.

SCHEDULE FOR STRIP FTG. REINF.

POUR	LONG'L REINF.	TRANSV. REINF.
FTG.	7 - 15M CONT.; 6 TOP (LL) & 1 CORNER BAR @ BOT. HK. OF 15M DWL'S (WALL)	15M (C/W 150 HK.) @ 150 O/C (UL)

SCHEDULE FOR WALL REINF.

POUR	HORIZ. REINF.	VERT. REINF.
WALL	15M CONT. @ 300 O/C	15M DWL'S (825 LG. W/ 300 HK.) @ 150 O/C BOT. (EMBED HK. 225 INTO FTG.); 15M @ 150 O/C
SLAB	2 - 15M CONT. (@ CORNERS OF DWL'S)	15M DWL'S (400 LG. W/ 300 HK.) @ 150 O/C (EMBED VERT. LEG 300 INTO WALL)
CURB	1 - 15M CONT.	15M DWL'S (300 LEGS) @ 400 O/C (EMBED HORIZ. LEG 100 INTO SLAB)

1 X-SECTION THRU. STONE RET. WALL.

S10 SCALE - 1 : 30

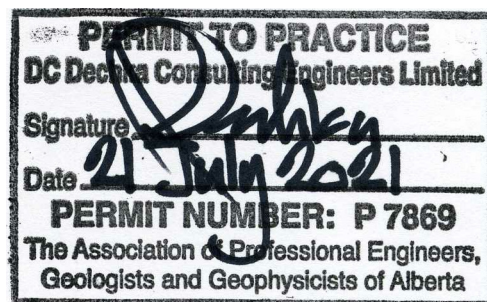
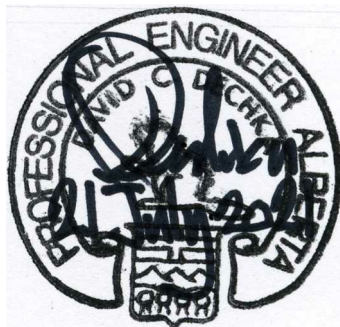

REV.	DESCRIPTION	DATE
1	GENERAL REVISIONS	27 JULY 2021
0	ISSUED FOR TENDER	21 JULY 2021

DC D.C. DECHKA CONSULTING ENGINEERS LIMITED
 27 Silverview Place N.W., Calgary, AB, T3B 3K5
 Phone: (403) 204 - 2234
 E-mail: dechka@telus.net

**PARKS CANADA - UPPER BANFF HOT SPRINGS
 STONE BLOCK RETAINING WALL UPGRADES**

CROSS-SECTION

PROJECT NUMBER:	21-153-01
DATE:	6 JULY 2021
SCALE:	AS SHOWN
DRAWN:	D.C.
CHECKED:	D.D.

DRAWING NUMBER:
S10

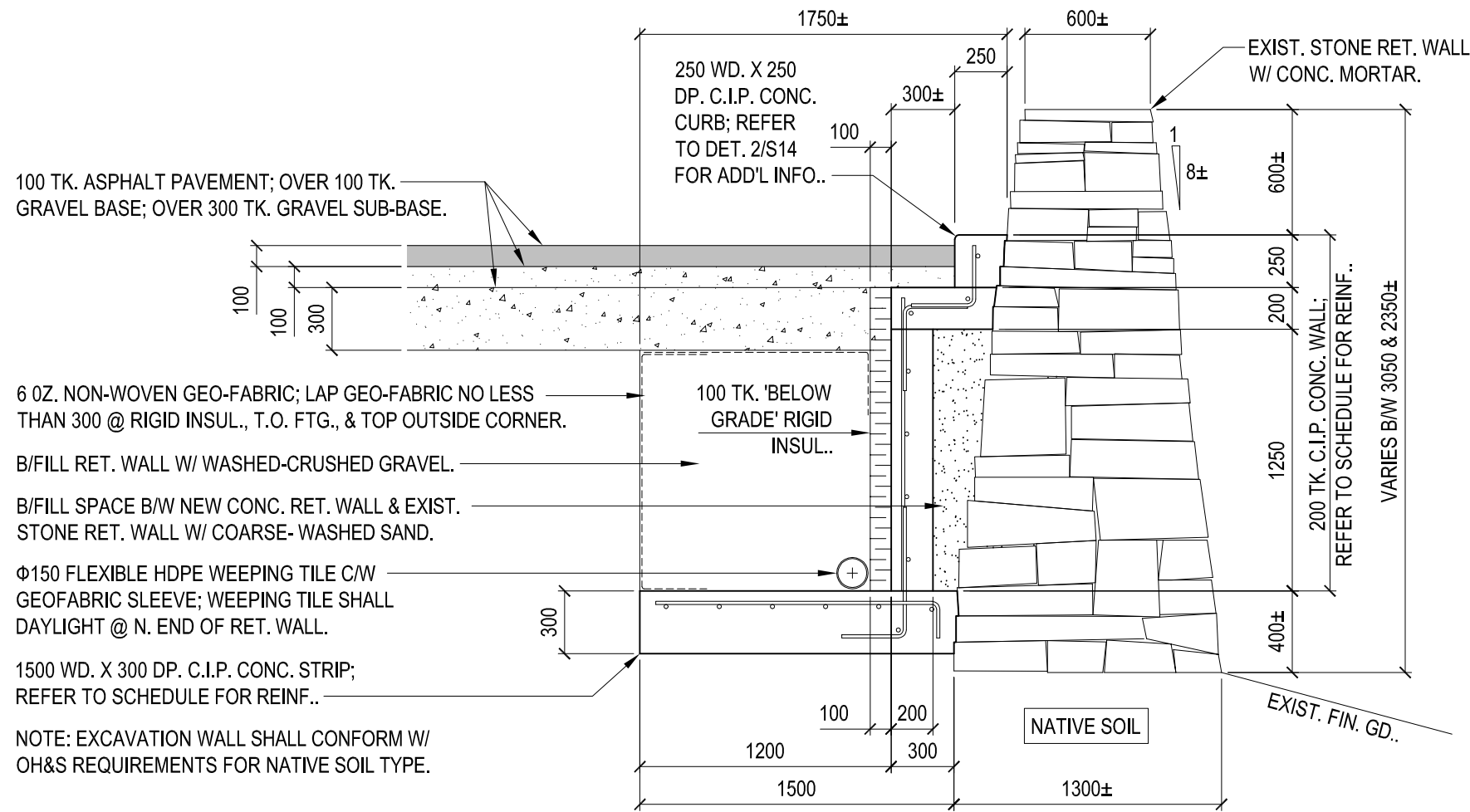

1 X-SECTION THRU. STONE RET. WALL.
S11 SCALE - 1 : 30

NOTES:

- AS-BUILT DIMEN'S OF EXIST. STONE RET. WALL ARE APPROX. & SHALL BE CONFIRMED BY CONTRACTOR.
- PRIOR TO PROCEEDING WITH THE WORK, THE CONTRACTOR SHALL REVIEW THE CONTRACT DWG'S, REPORT ANY DISCREPANCIES &/OR DEFICIENCIES TO THE STRUC. ENG'R, & THEN WAIT FOR FURTHER INSTRUCTIONS.
- IN NEW CONC. WALL, CLR. CONC. COVER TO REINF. SHALL BE 50 MM.
- IN NEW CONC. FTG., CLR. CONC. COVER TO REINF. SHALL BE 50 MM @ TOP & 75 MM @ SIDES & BOT..
- FACTORS OF SAFETY INCLUDES CONTRIBUTION FROM EXIST. STONE RET. WALL; FS (SLIDING) = 2.5; FS (OVERTURNING) = 3.8.
- REFER TO GEN. NOTES FOR COMPACTION OF ASPHALT & GRAVEL.

SCHEDULE FOR STRIP FTG. REINF.

POUR	LONG'L REINF.	TRANSV. REINF.
FTG.	7 - 15M CONT.; 6 TOP (LL) & 1 CORNER BAR @ BOT. HK. OF 15M DWL'S (WALL)	15M (C/W 150 HK.) @ 400 O/C (UL)

SCHEDULE FOR WALL REINF.

POUR	HORIZ. REINF.	VERT. REINF.
WALL	15M CONT. @ 300 O/C	15M DWL'S (825 LG. W/ 300 HK.) @ 400 O/C BOT. (EMBED HK. 225 INTO FTG.); 15M @ 400 O/C
SLAB	2 - 15M CONT. (@ CORNERS OF DWL'S)	15M DWL'S (400 LG. W/ 300 HK.) @ 400 O/C (EMBED VERT. LEG 300 INTO WALL)
CURB	1 - 15M CONT.	15M DWL'S (300 LEGS) @ 400 O/C (EMBED HORIZ. LEG 100 INTO SLAB)

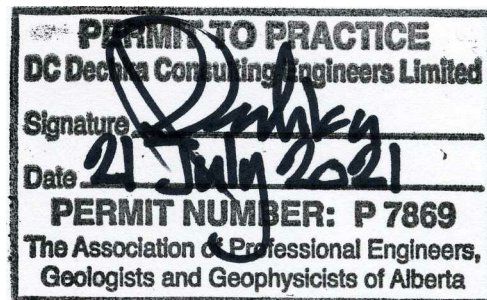
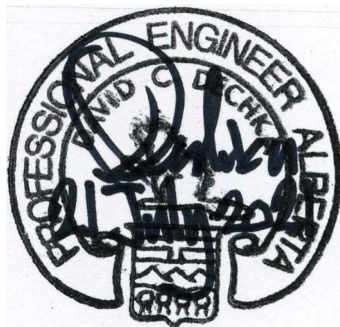

REV.	DESCRIPTION	DATE
1	GENERAL REVISIONS	27 JULY 2021
0	ISSUED FOR TENDER	21 JULY 2021

DC D.C. DECHKA CONSULTING ENGINEERS LIMITED
27 Silverview Place N.W., Calgary, AB, T3B 3K5
Phone: (403) 204 - 2234
E-mail: dechka@telus.net

PARKS CANADA - UPPER BANFF HOT SPRINGS
STONE BLOCK RETAINING WALL UPGRADES

CROSS-SECTION

PROJECT NUMBER:	21-153-01
DATE:	6 JULY 2021
SCALE:	AS SHOWN
DRAWN:	D.C.
CHECKED:	D.D.

DRAWING NUMBER:

S11

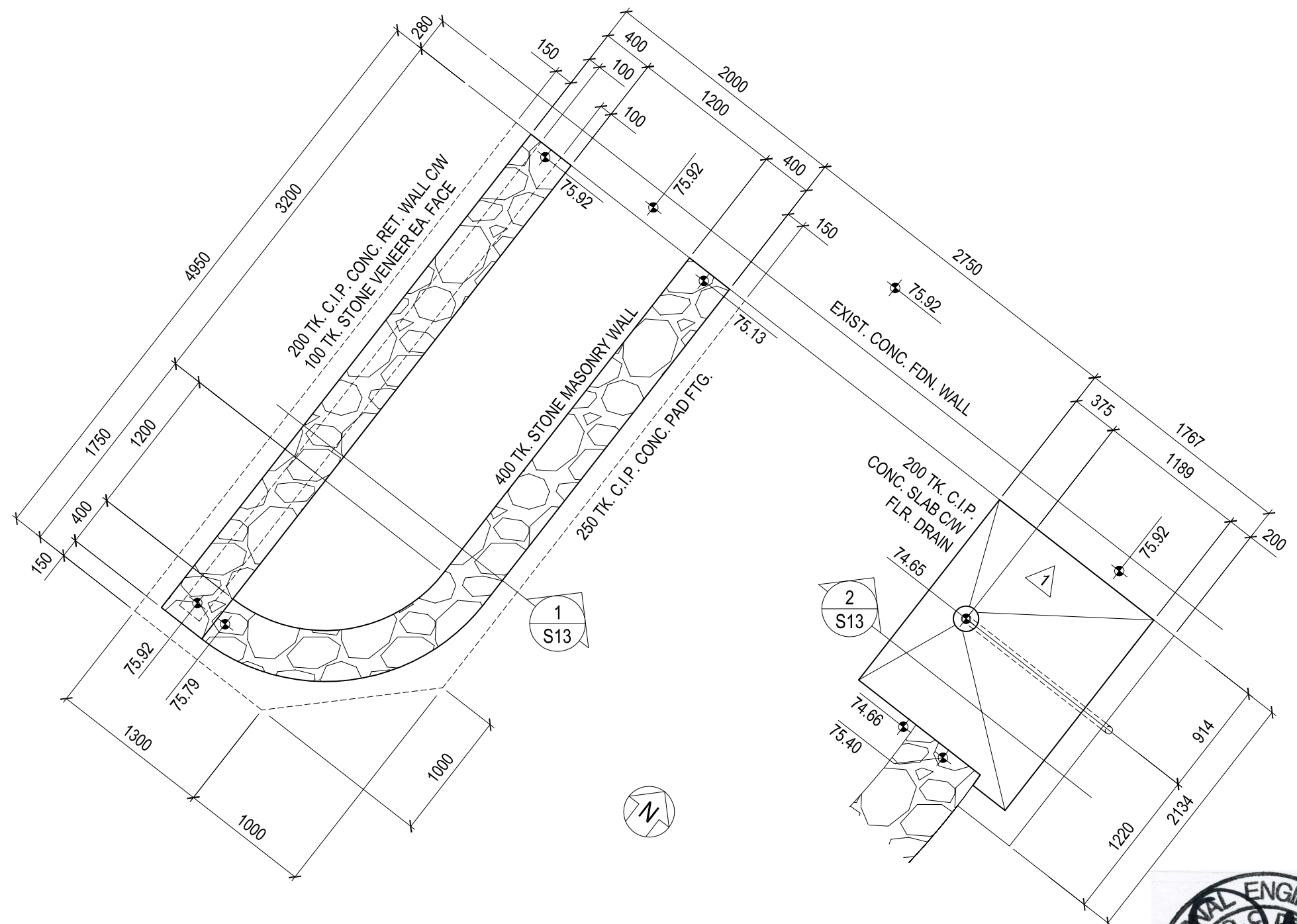

1 PARTIAL PLAN SHOWING NEW STONE WALL PLANTER & STORMWATER DRAIN.
 S12 SCALE - 1 : 40

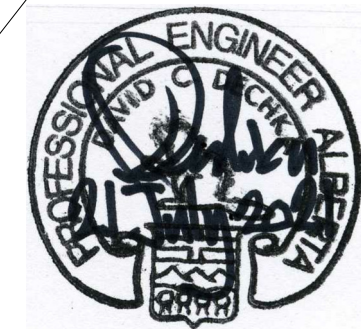

PERMIT TO PRACTICE
 DC Dechka Consulting Engineers Limited
 Signature: *[Signature]*
 Date: 21 July 2021
PERMIT NUMBER: P 7869
 The Association of Professional Engineers,
 Geologists and Geophysicists of Alberta

REV.	DESCRIPTION	DATE
1	SIZE OF STORM DRAIN SLAB INCREASED	13 SEPT. 2021
0	ISSUED FOR TENDER	21 JULY 2021

DC D.C. DECHKA CONSULTING ENGINEERS LIMITED
 27 Silverview Place N.W., Calgary, AB, T3B 3K5
 Phone: (403) 204 - 2234
 E-mail: dechka@telus.net

**PARKS CANADA - UPPER BANFF HOT SPRINGS
 STONE BLOCK RETAINING WALL UPGRADES**

PLAN

PROJECT NUMBER:	21-153-01
DATE:	6 JULY 2021
SCALE:	AS SHOWN
DRAWN:	D.C.
CHECKED:	D.D.

DRAWING NUMBER:
S12

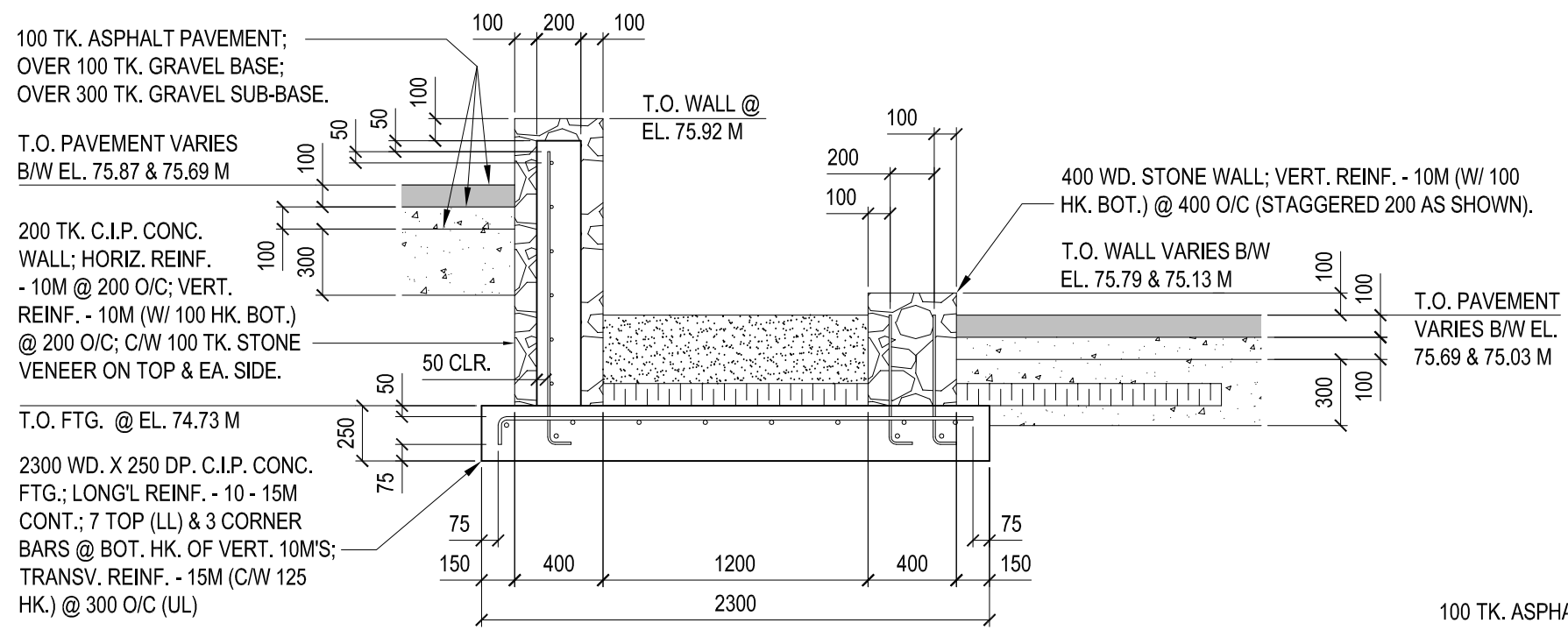

1 X-SECTION THRU. STONE WALL PLANTER.
S13 SCALE - 1 : 30

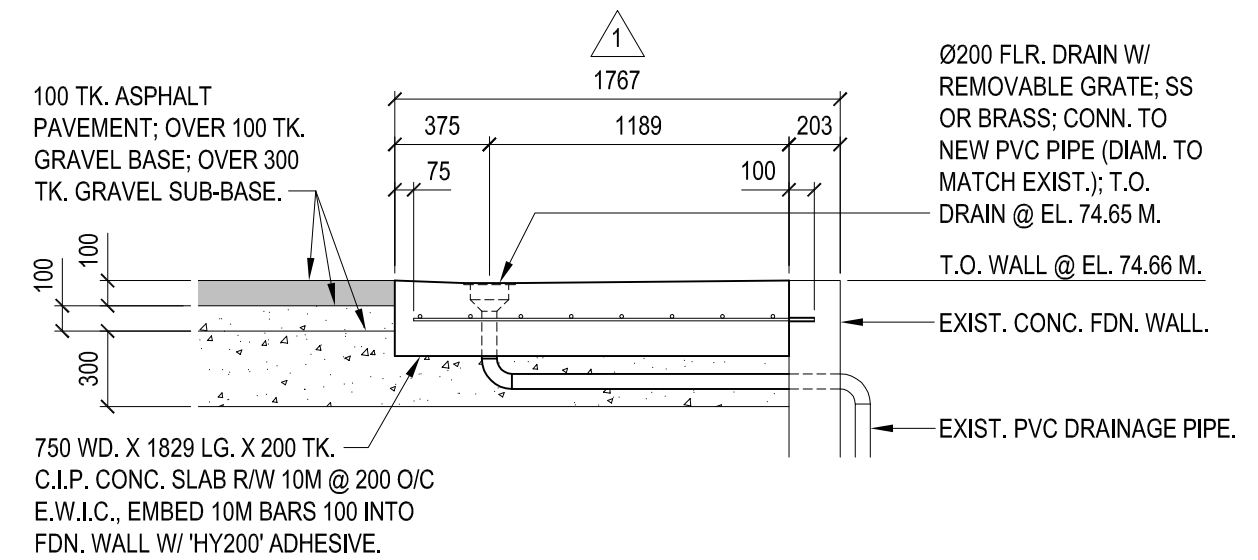

2 X-SECTION THRU. STORM DRAIN.
S13 SCALE - 1 : 30

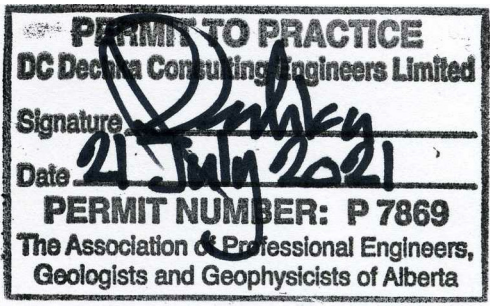
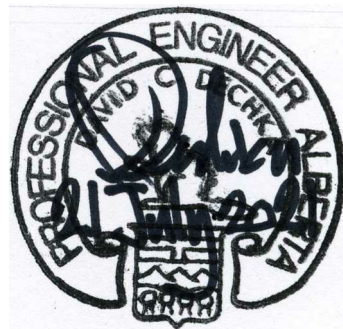

REV.	DESCRIPTION	DATE
1	SIZE OF STORM DRAIN SLAB INCREASED	13 SEPT. 2021
0	ISSUED FOR TENDER	21 JULY 2021

DC D.C. DECHKA CONSULTING ENGINEERS LIMITED
27 Silverview Place N.W., Calgary, AB, T3B 3K5
Phone: (403) 204 - 2234
E-mail: dechka@telus.net

PARKS CANADA - UPPER BANFF HOT SPRINGS
STONE BLOCK RETAINING WALL UPGRADES

CROSS-SECTIONS

PROJECT NUMBER:	21-153-01
DATE:	6 JULY 2021
SCALE:	AS SHOWN
DRAWN:	D.C.
CHECKED:	D.D.

DRAWING NUMBER:

S13

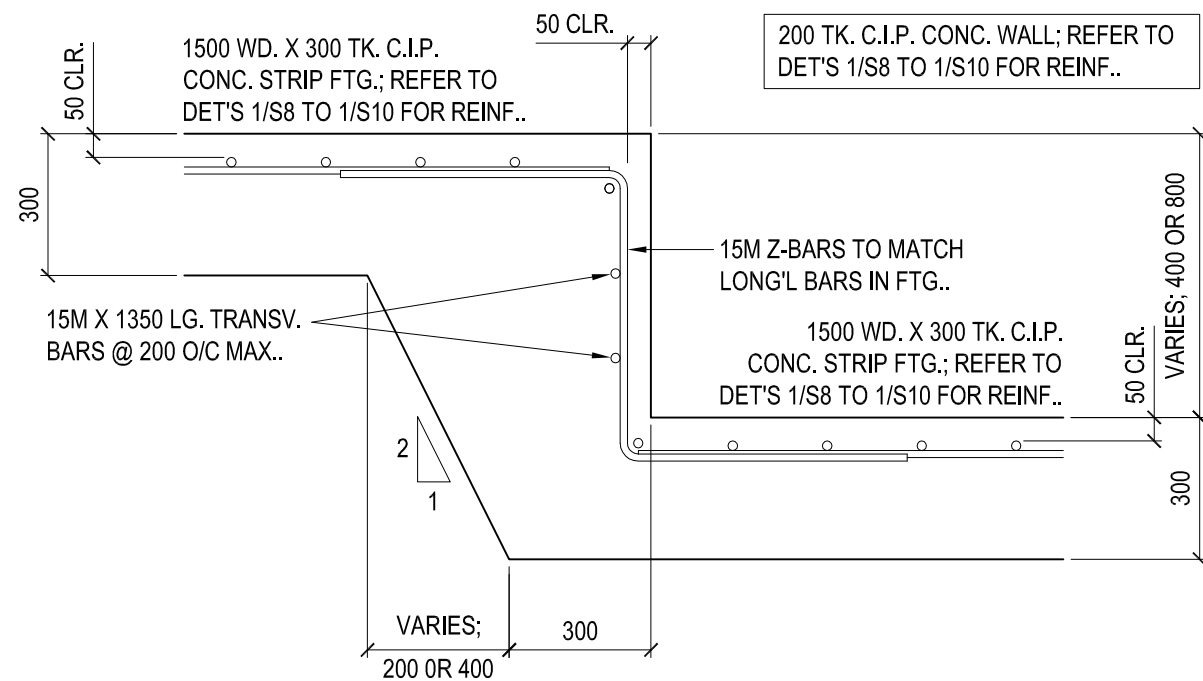

1 X-SECTION THRU. STEP FTG..
S14 SCALE - 1 : 16

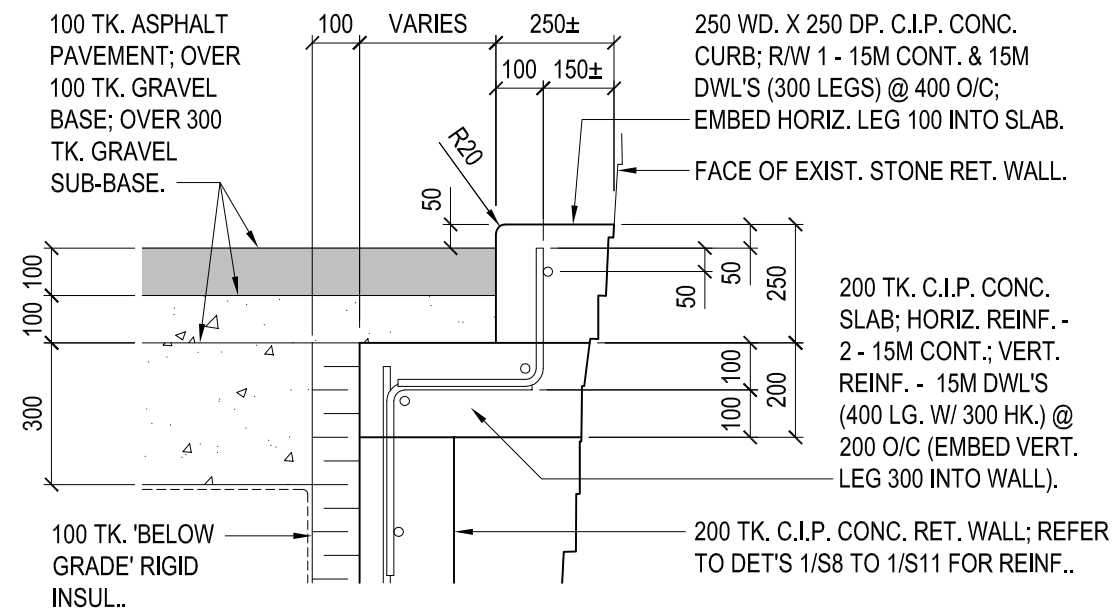

2 X-SECTION THRU. CONC. CURB..
S14 SCALE - 1 : 16

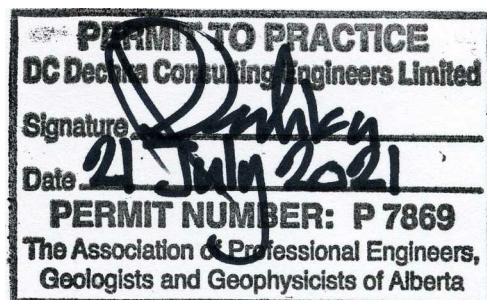
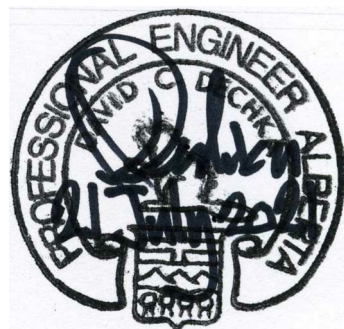

REV.	DESCRIPTION	DATE
1	CURB DETAIL REVISED	27 JULY 2021
0	ISSUED FOR TENDER	21 JULY 2021

DC D.C. DECHKA CONSULTING ENGINEERS LIMITED
 27 Silverview Place N.W., Calgary, AB, T3B 3K5
 Phone: (403) 204 - 2234
 E-mail: dechka@telus.net

PARKS CANADA - UPPER BANFF HOT SPRINGS
 STONE BLOCK RETAINING WALL UPGRADES

CROSS-SECTIONS

PROJECT NUMBER:	21-153-01
DATE:	6 JULY 2021
SCALE:	AS SHOWN
DRAWN:	D.C.
CHECKED:	D.D.

DRAWING NUMBER:
S14

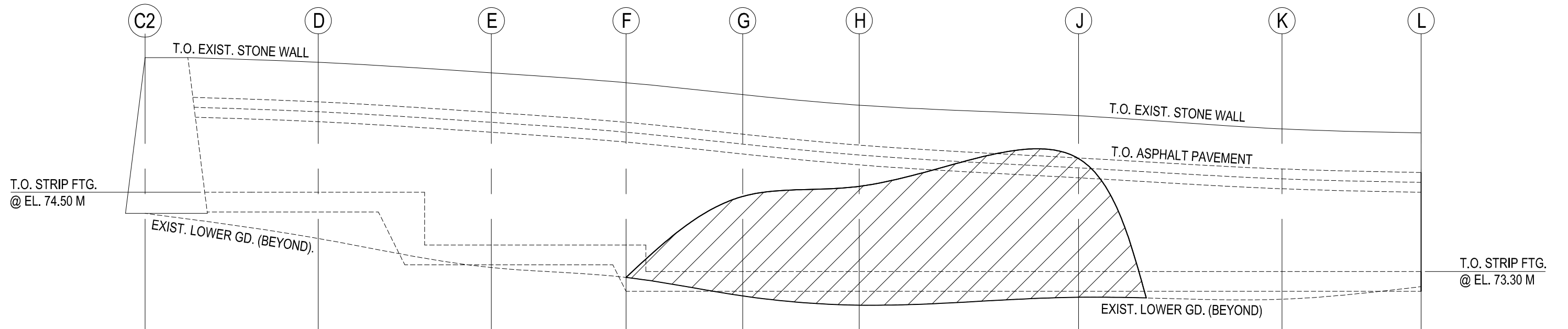

ELEV. SHOWING AREA OF EXIST. STONE RET. WALL REQUIRING REPAIRS.

1
S15
SCALE - 1 : 60

LEGEND:

 PORTION OF EXIST. STONE RET. WALL REQUIRING REPAIRS.

NOTES:

1. ALL LABELS & DIMENSIONS AS SHOWN ON DETAIL 1/S6, UNLESS NOTED OTHERWISE.
2. THE EXISTING RETAINING WALL IS A 'MASS' TYPE OF RETAINING WALL CONSTRUCTED FROM STONE MASONRY. THE STONE 'BLOCKS' ARE RUNDLE STONE. THE MORTAR IS CONCRETE. THE CONCRETE APPEARS TO HAVE A RELATIVELY SMALL COARSE AGGREGATE SIZE, LIKELY NO MORE THAN 6 MM.
3. A PORTION OF THE EXISTING MASS RETAINING WALL IS DAMAGED AND SHALL BE REBUILT. THE TOTAL VOLUME OF STONE MASONRY THAT REQUIRES REPAIR IS APPROXIMATELY 8 M³.
4. THE SHAPE OF THE DAMAGED PORTION IS SHOWN ON DETAIL 1/S15.
5. ONCE THE INSIDE FACE OF THE WALL IS EXCAVATED, THE INSIDE FACE SHALL SIMPLY BE REPOINTED. THE DEPTH OF REPOINTING SHALL NOT EXCEED 300 MM. TO ENSURE THAT NO STONE BLOCKS FALL FREE FROM THE WALL DURING THE REPOINTING PROCESS, THE MASON SHALL ENSURE THAT NO MORE THAN A SMALL PORTION OF THE WALL BE REMOVED AT ANY GIVEN TIME, LIKELY NO MORE THAN TWO OR THREE BLOCKS AT ONCE. AND THE WORK SHALL PROCEED FROM THE BASE OF THE WALL UP.
6. BEFORE THE WORK ON THE INSIDE FACE BEGINS, BOTH THE MASON AND THE STRUCTURAL ENGINEER SHALL REVIEW CONDITION OF THE STONE WALL, TO ENSURE THAT THE REPOINTING PROCESS IS THE BEST OPTION FOR REMEDIATING THE INSIDE FACE OF THE WALL.
7. ONCE THE INSIDE FACE HAS BEEN REPOINTED, THE NEW CONCRETE RETAINING WALL SHALL BE CONSTRUCTED.
8. ONCE THE NEW CONCRETE RETAINING WALL HAS PROPERLY CURED, THE OUTSIDE FACE OF THE WALL CAN BE REBUILT. TO ENSURE THAT NO STONES FALL FREE DURING THE REBUILDING PROCESS, THE MASON SHALL ENSURE THAT NO MORE THAN A SMALL PORTION OF THE WALL BE REMOVED AT ANY GIVEN TIME, AND THE WORK SHALL PROCEED FROM THE BASE OF THE WALL UP. THE NUMBER OF STONE BLOCKS THAT CAN BE REMOVED AT ONCE IS AT THE DISCRETION OF THE MASON, WITH THE SAFETY OF THE WORKERS BEING THE PRIMARY CONCERN.
9. IF AT ANY GIVEN TIME, EITHER THE MASON OR THE STRUCTURAL ENGINEER THINKS THAT TEMPORARY SHORING IS REQUIRED, SUITABLE OPTIONS SHALL BE DISCUSSED IN DETAIL BY BOTH PARTIES, AND THEN APPROVED IN WRITING BY BOTH PARTIES.

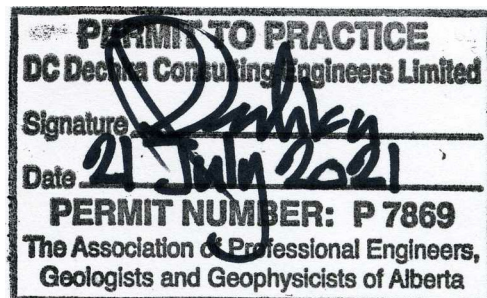
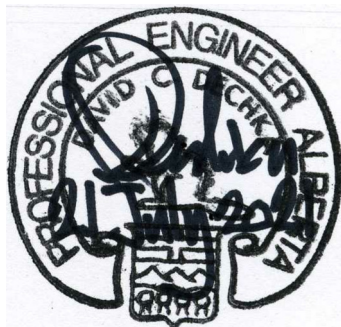

DC D.C. DECHKA CONSULTING ENGINEERS LIMITED
27 Silverview Place N.W., Calgary, AB, T3B 3K5
Phone: (403) 204 - 2234
E-mail: dechka@telus.net

PARKS CANADA - UPPER BANFF HOT SPRINGS
STONE BLOCK RETAINING WALL UPGRADES

ELEVATION

PROJECT NUMBER:	21-153-01
DATE:	6 JULY 2021
SCALE:	AS SHOWN
DRAWN:	D.C.
CHECKED:	D.D.

DRAWING NUMBER:

S15

REV.	DESCRIPTION	DATE
1	POUR LIFTS & DOWELS REMOVED	27 JULY 2021
0	ISSUED FOR TENDER	21 JULY 2021

GENERAL NOTES:

BACKGROUND:

- THE SITE IS THE UPPER BANFF HOT SPRINGS, BANFF NATIONAL PARK, ALBERTA. PARKS CANADA HAS FULL OPERATIONAL CONTROL OF THE SITE.
- DIRECTLY SOUTH OF THE POOL BUILDING IS AN EXISTING MASS RETAINING WALL CONSTRUCTED FROM STONE MASONRY. THE EXACT AGE OF THE WALL IS UNKNOWN, BUT ASSUMED TO HAVE BEEN CONSTRUCTED IN THE LATE 1800'S OR EARLY 1900'S.
- THE BASE OF THE RETAINING WALL IS FOUNDED ON THE CREST OF A RELATIVELY STEEP ESCARPMENT. THE UPPER LEVEL IS PAVED WITH ASPHALT AND HAS RECENTLY BEEN USED AS A STORAGE AREA FOR ROAD-CLEARING SNOW. THE NEARBY ASPHALT PAVEMENT IS IN VERY POOR CONDITION.
- RECENTLY, THE WALL APPEARS TO HAVE SUFFERED SOME STRUCTURAL DISTRESS. THE DISTRESS IS LIKELY A CONSEQUENCE OF UNANTICIPATED OVERLOAD AND EXCESS HYDROSTATIC PRESSURE, WHICH IS THOUGHT TO BE A DIRECT RESULT SNOW-CLEARING PILES OF SNOW STORED IMMEDIATE NEXT TO THE WALL.

SCOPE OF WORK:

- THE UPPER BANFF HOT SPRINGS IS A PROTECTED HISTORICAL SITE, AND AS SUCH THE 'FABRIC' (OR OUTWARD APPEARANCE) OF THE INFRASTRUCTURE SHALL BE PRESERVED WHENEVER POSSIBLE. AND IN THAT REGARD, ONLY A SMALL PORTION OF THE STONE RETAINING WALL WILL BE REBUILT. THE BULK OF THE WALL WILL REMAIN UNTOUCHED, AND STRENGTHENED BY CONSTRUCTING A NEW CAST-IN-PLACE CONCRETE RETAINING WALL ALONG THE INSIDE FACE.
- THE WORK WILL INCLUDE NEW ASPHALT PAVEMENT (IN THE IMMEDIATE AREA), RECONSTRUCTION OF A NEARBY STONE-WALL PLANTER, AND A NEW STORMWATER DRAIN.
- THE TOP OF THE NEW CONCRETE RETAINING WALL WILL BE CAST BELOW THE UNDERSIDE OF THE PAVEMENT.

SERVICE (UNFACTORED) LOADS:

OVERBURDEN (1.8 M OF SNOW) = 11.00 KPA
 UNIT WEIGHT OF STONE WALL = 26 KN/M³
 UNIT WEIGHT OF CONCRETE = 23.5 KN/M³
 UNIT WEIGHT OF WASHED-CRUSHED GRAVEL = 16.5 KN/M³
 SOIL LOADS - REFER TO SECTION ON SOIL PROPERTIES
 IMPORTANCE CATEGORY - NORMAL

SOIL PROPERTIES:

- IN THE ABSENCE OF A GEOTECHNICAL REPORT, THE FOLLOWING SOIL PARAMETERS WERE ASSUMED FOR THE DESIGN OF THE FOUNDATION.
- UNIT WEIGHT OF SOIL = 20 KN/M³
- AT-REST LATERAL EARTH PRESSURE COEFFICIENT, $K_0 = 0.50$
- ACTIVE LATERAL EARTH PRESSURE COEFFICIENT, $K_a = 0.33$
- PASSIVE LATERAL EARTH PRESSURE COEFFICIENT, $K_p = 3.00$
- IN ABSENCE OF A SOLUBLE SULPHATE TEST, THE CONCENTRATION OF WATER-SOLUBLE SULPHATES IN THE SOILS ASSUMED TO BE GREATER THAN 2 PERCENT; CLASS S-1 EXPOSURE (VERY SEVERE).

- THE FROST DEPTH ADJACENT TO HEATED STRUCTURES SHALL BE NO GREATER THAN 1.2 M; FOR UNHEATED (ISOLATED) STRUCTURES, NO GREATER THAN 2.1 M.
- THE TOTAL VOLUMETRIC FLOW INTO THE WEeping TILE SYSTEM SHALL BE NO MORE THAN 100 LITERS PER MINUTE.
- PRIOR TO CONSTRUCTION OF THE NEW CONCRETE RETAINING WALL, THE OWNER SHALL RETAIN A LOCALLY-BASED GEOTECHNICAL ENGINEER, REGISTERED IN THE PROVINCE OF ALBERTA, TO COMPLETE A FIELD REVIEW OF THE OPEN EXCAVATIONS AND THEREBY VERIFY THE SOIL CONDITIONS.
- THE HEIGHT OF THE RETAINING WALL, AS WELL AS THE DEPTH OF BACKFILL EACH SIDE OF THE WALL, IS NOT CONSISTENT ALONG THE LENGTH OF THE WALL. THE VARIABLE NATURE OF THE WALL MEANS THAT THE FACTORS OF SAFETY ARE NOT CONSISTENT ALONG THE LENGTH OF WALL. THAT BEING SAID, THE FACTOR OF SAFETY AGAINST TRANSLATION IS NO LESS THAN 2.0 AND THE FACTOR OF SAFETY AGAINST ROTATION IS NO LESS THAN 2.6.

DESIGN CODES:

- THE DESIGN WAS COMPLETED INSUBSTANTIAL ACCORDANCE WITH THE FOLLOWING CODES:
- NATIONAL BUILDING CODE 2019 (ALBERTA EDITION).
- CSA STANDARD A23.3, DESIGN OF CONCRETE STRUCTURES.

GENERAL CONSTRUCTION NOTES:

- THE STRUCTURAL CONTRACT DRAWINGS CONSIST OF DRAWINGS S1 TO S19.
- THE CONTRACTOR SHALL ENSURE THAT HE HAS ALL OF THE CONTRACT DRAWINGS.
- PRIOR TO PROCEEDING WITH THE WORK, THE CONTRACTOR SHALL REVIEW THE CONTRACT DRAWINGS, REPORT ANY DISCREPANCIES &/OR DEFICIENCIES TO THE STRUCTURAL ENGINEER, AND THEN WAIT FOR FURTHER INSTRUCTIONS.

EARTHWORK:

- EXCAVATION WALLS SHALL COMPLY WITH THE RECOMMENDATIONS OUTLINED IN THE GUIDELINES DETAILED IN THE 'GENERAL SAFETY REGULATION' OF THE OCCUPATIONAL HEALTH AND SAFETY ACT (CURRENT EDITION). IN THE EVENT THAT SITE RESTRICTIONS DICTATE OTHERWISE, THE CONTRACTOR SHALL CONTACT THE STRUCTURAL ENGINEER FOR ADDITIONAL INSTRUCTIONS.
- ONCE THE EXCAVATION IS COMPLETE, THE BASE OF THE EXCAVATION SHALL BE INSPECTED BY THE GEOTECHNICAL ENGINEER TO REVIEW THE CONDITION OF THE NATIVE MATERIAL. UNUSUAL SUBSURFACE CONDITIONS MAY WARRANT CHANGES TO THE STRUCTURAL DESIGN, AS RECOMMENDED BY EITHER THE STRUCTURAL ENGINEER OR THE GEOTECHNICAL ENGINEER.

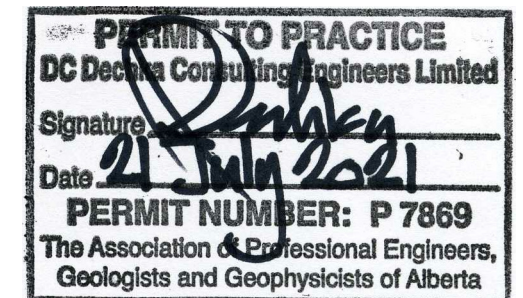
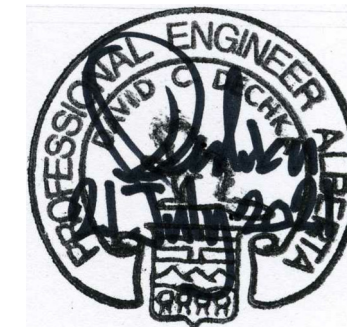

REV.	DESCRIPTION	DATE
0	ISSUED FOR TENDER	21 JULY 2021

DC D.C. DECHKA CONSULTING ENGINEERS LIMITED
 27 Silverview Place N.W., Calgary, AB, T3B 3K5
 Phone: (403) 204 - 2234
 E-mail: dechka@telus.net

PARKS CANADA - UPPER BANFF HOT SPRINGS
 STONE BLOCK RETAINING WALL UPGRADES

GENERAL NOTES

PROJECT NUMBER:	21-153-01
DATE:	6 JULY 2021
SCALE:	AS SHOWN
DRAWN:	D.C.
CHECKED:	D.D.

DRAWING NUMBER:

S16

- 'TUFA' IS A VARIETY OF LIMESTONE FORMED WHEN CARBONATE MINERALS PRECIPITATE OUT OF AMBIENT TEMPERATURE WATER. NOT ONLY IS IT PREVALENT IN THE IMMEDIATE AREA, IT IS ALSO A PROTECTED GEOLOGICAL FORMATION. IN THE EVENT THAT ANY TUFA IS ENCOUNTERED DURING EXCAVATION, ALL WORK SHALL CEASE UNTIL FURTHER DIRECTION ON HOW TO PROCEED IS PROVIDED BY PARKS CANADA.
- THE NATIVE MATERIAL BENEATH NEW CONCRETE FOOTINGS SHALL BE INORGANIC AND UNDISTURBED. IN THE EVENT THAT ANY INORGANIC MATERIAL IS DISTURBED DURING EXCAVATION, THE MATERIAL SHALL BE RE-COMPACTED TO 100 PERCENT STANDARD PROCTOR DENSITY, OR REMOVED AND THE DEPRESSIONS FILLED WITH LEAN MIX CONCRETE. ANY ORGANIC MATERIAL OR SOFT OR MOIST LAYERS OF INORGANIC MATERIAL SHALL BE REMOVED AND REPLACED WITH COMPETENT MATERIAL, AND COMPACTED TO 100 PERCENT STANDARD PROCTOR DENSITY, OR THE MATERIAL SHALL BE REMOVED AND THE DEPRESSIONS FILLED WITH LEAN MIX CONCRETE.
- THE CONTRACTOR SHALL ENSURE THE EXCAVATION IS PROTECTED FROM WATER PONDING ON THE BASE. TO PREVENT ANY PONDING, ISOLATED 'POCKETS' SHALL BE AVOIDED AND THE BASE OF THE EXCAVATION SHALL SLOPE TOWARDS A TEMPORARY SUMP HOLE. THE SUMP HOLE SHALL BE EQUIPPED WITH A SUMP PUMP.
- THE 'WASHED-CRUSHED GRAVEL' BACKFILL SHALL BE LIGHTLY TAMPED TO CONSOLIDATE THE INTERLOCKING AGGREGATE.
- THE 'COARSE-WASHED SAND' BACKFILL SHALL BE LIGHTLY TAMPED TO CONSOLIDATE THE INTERLOCKING AGGREGATE.
- COMPACTION OF BACKFILLS SHALL BE VERIFIED BY THE GEOTECHNICAL ENGINEER. AT LEAST ONE INSPECTION BY THE GEOTECHNICAL ENGINEER IS REQUIRED TO REVIEW THE CONTRACTOR'S COMPACTION TECHNIQUES. INSPECTIONS ARE REQUIRED AT THE ONSET OF COMPACTION.
- THE CONTRACTOR SHALL GIVE THE GEOTECHNICAL ENGINEER A MINIMUM OF 48 HOURS NOTICE PRIOR TO THE TIME REQUIRED FOR EACH INSPECTION.
- COLD WEATHER EARTHWORK IS NOT RECOMMENDED. HOWEVER, IN THE EVENT THAT THE CONTRACTOR CHOOSES TO WORK THROUGH THE WINTER MONTHS, THE BASE OF THE EXCAVATION SHALL BE PROTECTED FROM FREEZING. THE METHODS OF HOARDING AND HEATING THE EXCAVATION SHALL BE REVIEWED AND APPROVED BY BOTH THE GEOTECHNICAL ENGINEER AND STRUCTURAL ENGINEER. IN ABSOLUTELY NO INSTANCE SHALL THE MATERIAL USED FOR BACKFILL (INCLUDING ROAD BASE) BE FROZEN.

1

DRAINAGE:

- THE ASPHALT SURFACE SHALL BE SLOPED TO PROVIDE POSITIVE DRAINAGE TOWARDS THE STORMWATER DRAIN. REFER TO DETAIL 1/S4 FOR THE FINISH GRADE OF THE ASPHALT.
- TO CONTROL SURFACE RUNOFF THAT MAY PERCOLATE BELOW THE ASPHALT SURFACE, WEEPING TILE IS REQUIRED ALONG THE RETAINED-EARTH SIDE OF THE RETAINING WALL. THE WEEPING TILE SHALL DISCHARGE TO DAYLIGHT AT NORTH END OF THE WALL, WHERE IT WILL PASS THROUGH A CORED HOLE IN THE EXISTING CONCRETE FOUNDATION WALL, JUST NORTH OF THE EXISTING STONE RETAINING WALL.

DRAINAGE ACCESSORIES AND WATERPROOFING:

1

- WEEPING TILE SHALL BE 150 MM DIAMETER, PERFORATED, FLEXIBLE, HDPE PIPE; 'BIG O', OR EQUIVALENT. ALTERNATE PRODUCTS SHALL BE APPROVED IN WRITING BY THE STRUCTURAL ENGINEER.
- ABRUPT CHANGES IN DIRECTION AND/OR CONNECTIONS BETWEEN SECTIONS OF WEEPING TILE SHALL INCORPORATE COMPATIBLE FITTINGS (ELBOWS, COUPLINGS, T-CONNECTIONS, Y-CONNECTIONS, ETC.). TO ENSURE COMPATIBILITY, ALL FITTINGS SHALL BE SUPPLIED BY THE WEEPING TILE MANUFACTURER.
- THE 6 OUNCE NON-WOVEN GEOFABRIC SHALL BE (BLANK BY BLANK), OR EQUIVALENT. ALTERNATE PRODUCTS SHALL BE APPROVED IN WRITING BY THE STRUCTURAL ENGINEER.

- THE STRUCTURAL ENGINEER SHALL REVIEW THE INSTALLATION OF THE DRAINAGE SYSTEM (INCLUDING THE GEOTEXTILE) PRIOR TO BACKFILLING THE WALL. THE CONTRACTOR SHALL GIVE THE STRUCTURAL ENGINEER A MINIMUM OF 48 HOURS NOTICE PRIOR TO THE TIME REQUIRED FOR THE INSPECTION.

CONCRETE:

- ALL CONCRETE SHALL BE SUPPLIED BY A CSA APPROVED READY-MIX COMPANY.
- IN THE ABSENCE OF A SOLUBLE SULPHATE TEST, THE CONCRETE AND CURING REQUIREMENTS FOR ALL WALLS AND FOOTINGS SHALL COMPLY WITH THE REQUIREMENTS FOR A CLASS S-1 EXPOSURE; MAXIMUM WATER-TO-CEMENT RATIO OF 0.40, 56-DAY COMPRESSIVE STRENGTH OF 35 MPA, 20 MM MAXIMUM NOMINAL COARSE AGGREGATE SIZE, 4 TO 7 PERCENT AIR CONTENT, HS OR HSB TYPE CEMENT (TYPE 50); CURE CONCRETE AT NO LESS THAN 10°C FOR NO LESS THAN 7 DAYS, OR THE TIME NECESSARY TO GAIN 70 PERCENT OF THE COMPRESSIVE CYLINDER STRENGTH.
- TO LIMIT THE EXTENT OF SHRINKAGE AS MUCH AS POSSIBLE, THE CEMENT CONTENT AND WATER/CEMENT RATIO SHALL BE MINIMIZED. WATER-REDUCING ADMIXTURES AND/OR SUPERPLASTICIZERS MAY BE USED TO REDUCE THE WATER/CEMENT RATIO.
- CALCIUM CHLORIDE, OR ANY ADMIXTURE FORMULATION CONTAINING CHLORIDE, SHALL NOT BE USED.
- TIMBER 'LADDERS', EMBEDDED INTO THE CONCRETE AND USED TO BRACE THE TOP OF THE RETAINING WALL FORMWORK, ARE NOT ALLOWED.
- ALL CONCRETE SHALL BE PLACED IN ITS FINAL POSITION WITHIN 90 MINUTES OF BATCHING.
- CONCRETE SHALL BE PROTECTED FROM PREMATURE DRYING AND EXTREMES OF TEMPERATURE.
- COLD-WEATHER CONCRETING IS NOT RECOMMENDED. HOWEVER, IN THE EVENT THAT THE CONTRACTOR CHOOSES TO WORK THROUGH THE WINTER MONTHS, THE CONCRETE SHALL BE PROTECTED FROM FREEZING.
- CONCRETE SHALL NOT BE PLACED AGAINST FROZEN EARTH.
- IF THE AMBIENT TEMPERATURE IS EXPECTED TO FALL BELOW 10°C, THE CONTRACTOR SHALL PROVIDE HEATING AND/OR HOARDING IN ACCORDANCE WITH THE EXPOSURE CLASSIFICATION (7 DAYS). THE METHODS OF HOARDING AND HEATING THE CONCRETE SHALL BE REVIEWED AND APPROVED IN WRITING BY THE STRUCTURAL ENGINEER.
- ALL FORMWORK MUST REMAIN IN PLACE IN ACCORDANCE WITH THE EXPOSURE CLASSIFICATION (7 DAYS).
- FOR EACH CONCRETE POUR, THE CONTRACTOR SHALL RETAIN A CONCRETE TESTING AGENCY TO CAST AT LEAST THREE 4-INCH-DIAMETER BY 8-INCH-LONG CONCRETE CYLINDERS, TO BE USED FOR VERIFICATION OF THE COMPRESSIVE STRENGTH. ADDITIONAL CYLINDERS MAY BE REQUIRED TO DETERMINE THE STRENGTH GAIN PRIOR TO 56 DAYS.
- THE TESTING AGENCY SHALL RECORD THE SLUMP AND LEVEL OF AIR ENTRAINMENT.

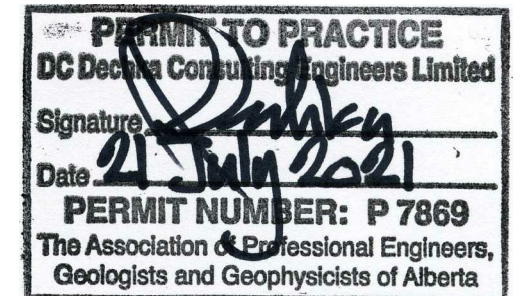
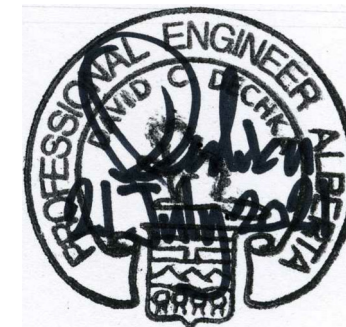

REV.	DESCRIPTION	DATE
1	GENERAL REVISIONS	27 JULY 2021
0	ISSUED FOR TENDER	21 JULY 2021

DC D.C. DECHKA CONSULTING ENGINEERS LIMITED
 27 Silverview Place N.W., Calgary, AB, T3B 3K5
 Phone: (403) 204 - 2234
 E-mail: dechka@telus.net

PARKS CANADA - UPPER BANFF HOT SPRINGS
 STONE BLOCK RETAINING WALL UPGRADES

GENERAL NOTES

PROJECT NUMBER:	21-153-01
DATE:	6 JULY 2021
SCALE:	AS SHOWN
DRAWN:	D.C.
CHECKED:	D.D.

DRAWING NUMBER:

S17

CONCRETE REINFORCEMENT:

- ALL STEEL REINFORCEMENT SHALL CONFORM TO CSA STANDARD G30.18-92.
- ALL STEEL REINFORCEMENT SHALL HAVE A MINIMUM SPECIFIED YIELD STRENGTH OF 400 MPA.
- UNLESS NOTED OTHERWISE ON THE DETAILED DRAWINGS, THE MINIMUM CLEAR CONCRETE COVER TO THE STEEL REINFORCEMENT SHALL CONFORM TO THE VALUES LISTED IN TABLE 1.

TABLE 1 - CONCRETE COVER FOR CAST-IN-PLACE CONCRETE ELEMENTS

STRUCTURAL ELEMENT	COVER
CAST AGAINST AND PERMANENTLY EXPOSED TO EARTH	75 MM
FOOTINGS	50 MM
WALLS	50 MM

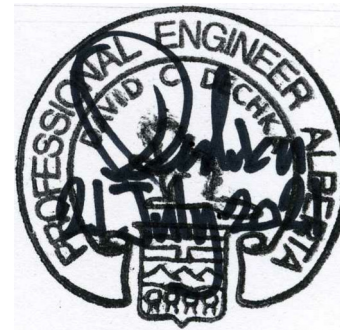

- ALL BAR SUPPORT CHAIRS SHALL BE PLASTIC. BAR SUPPORT CHAIRS SHALL BE SUFFICIENT IN NUMBER, STRENGTH AND STABILITY TO MAINTAIN THE POSITION OF THE FULL LENGTH OF HORIZONTAL (AND VERTICAL) REINFORCEMENT. IF SPACER BARS ARE USED TO SUPPORT THE STEEL REINFORCEMENT, THEY SHALL BE NOT LESS THAN 15M.
- THE REINFORCEMENT IN THE FOOTINGS SHALL BE PROPERLY CHAIRED OFF THE GRAVEL BASE. 'SAND CHAIRS' SHALL BE USED. THE BARS SHALL NOT BE 'HOOKED' INTO PLACE. REFER TO DETAIL 1/S19.
- IN LIEU OF SUPPORT CHAIRS AND ONLY FOR REINFORCEMENT IN FOOTINGS PLACED DIRECTLY UPON SOIL, NORMAL-WEIGHT (NOT LIGHT-WEIGHT NOR SEMI-LIGHT-WEIGHT) CONCRETE PAVERS MAY BE USED TO SUPPORT THE REINFORCEMENT, PROVIDING THAT THE BEARING AREA OF EACH PAVER IS NO LESS THAN 100 MM X 100 MM. IN LIEU OF CONCRETE PAVERS, INVERTED U-BARS MAY BE USED TO SUPPORT THE REINFORCEMENT, PROVIDING THE DEPTH OF EMBEDMENT OF THE ENDS OF THE BARS INTO THE SOIL IS SUFFICIENT LENGTH TO SUPPORT BOTH THE WEIGHT OF THE REINFORCEMENT AND THE WORKERS USED TO PLACE THE CONCRETE. THE BARS SHALL NOT BE SUSPENDED FROM TIE-WIRE.
- METAL TIE-WIRE (USED TO SECURE THE STEEL REINFORCEMENT) SHALL NOT EXTEND MORE THAN 5 MM INTO THE CONCRETE COVER.
- THE HOOKED DOWELS BETWEEN THE STRIP FOOTINGS AND WALLS SHALL BE TIED IN PLACE. THEY SHALL NOT BE 'WET SET'.
- UNLESS NOTED OTHERWISE, THE MINIMUM LENGTH OF LAP SPLICE FOR 10M BARS SHALL NOT BE LESS THAN 400 MM. FOR 15M BARS, 600 MM. NO TWO ADJACENT BARS SHALL BE SPLICED AT THE SAME LOCATION.
- THE INSIDE DIAMETER OF BENT BARS SHALL CONFORM TO THE VALUES LISTED IN TABLE 2.

TABLE 2 - INSIDE BEND DIAMETER

BEND TYPE	BAR SIZE	
	10M	15M
STANDARD BENDS AND HOOKS	75 MM	100 MM
TIES AND HAIRPINS	50 MM	NOT APPLICABLE

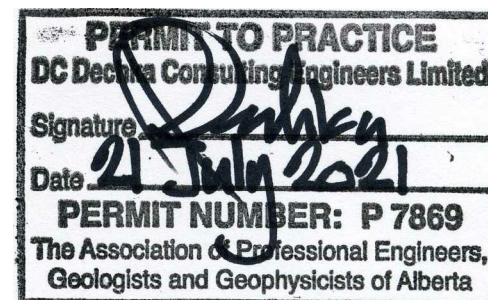

- THE STRUCTURAL ENGINEER SHALL REVIEW THE PLACEMENT OF THE STEEL REINFORCEMENT PRIOR TO EACH POUR. THE CONTRACTOR SHALL GIVE THE STRUCTURAL ENGINEER A MINIMUM OF 48 HOURS NOTICE PRIOR TO THE TIME REQUIRED FOR EACH INSPECTION.

CONCRETE ACCESSORIES:

- ALL DRILLED DOWEL ADHESIVES SHALL BE MANUFACTURED BY HILTI (CANADA) LTD. AND INSTALLED IN DIRECT ACCORDANCE WITH THE MANUFACTURER'S DIRECTIONS. NO SUBSTITUTIONS WILL BE PERMITTED.

MASONRY:

- THE EXISTING RETAINING WALL IS A 'MASS' TYPE OF RETAINING WALL CONSTRUCTED FROM STONE MASONRY. THE STONE 'BLOCKS' ARE RUNDLE STONE. THE MORTAR IS CONCRETE. THE CONCRETE APPEARS TO HAVE A RELATIVELY SMALL COARSE AGGREGATE SIZE, LIKELY NO MORE THAN 6 MM.
- A PORTION OF THE EXISTING MASS RETAINING WALL IS DAMAGED AND NEEDS TO BE REBUILT. THE TOTAL VOLUME OF STONE MASONRY THAT NEEDS TO BE REPAIRED IS APPROXIMATELY 8 M³.
- THE SHAPE OF THE DAMAGED PORTION IS SHOWN ON DETAIL 1/S14.
- ONCE THE INSIDE FACE OF THE WALL IS EXCAVATED, THE INSIDE FACE WILL SIMPLY BE REPOINTED. THE DEPTH OF REPOINTING SHALL NOT EXCEED 300 MM. TO ENSURE THAT NO STONE BLOCKS FALL FREE FROM THE WALL DURING THE REPOINTING PROCESS, THE MASON SHALL ENSURE THAT NO MORE THAN A SMALL PORTION OF THE WALL BE REMOVED AT ANY GIVEN TIME, LIKELY NO MORE THAN TWO OR THREE BLOCKS AT ONCE, AND THE WORK SHALL PROCEED FROM THE BASE OF THE WALL UP.
- BEFORE THE WORK ON THE INSIDE FACE BEGINS, BOTH THE MASON AND THE STRUCTURAL ENGINEER SHALL REVIEW CONDITION OF THE STONE WALL, TO ENSURE THAT THE REPOINTING PROCESS IS THE BEST OPTION FOR REMEDIATING THE INSIDE FACE OF THE WALL.
- ONCE THE INSIDE FACE HAS BEEN REPOINTED, THE NEW CONCRETE RETAINING WALL SHALL BE CONSTRUCTED.
- ONCE THE NEW CONCRETE RETAINING WALL HAS PROPERLY CURED, AND BEFORE COARSE-WASHED SAND BACKFILL IS PLACED, THE OUTSIDE FACE OF THE WALL CAN BE REBUILT. TO ENSURE THAT NO STONES FALL FREE DURING THE REBUILDING PROCESS, THE MASON SHALL ENSURE THAT NO MORE THAN A SMALL PORTION OF THE WALL BE REMOVED AT ANY GIVEN TIME, AND THE WORK SHALL PROCEED FROM THE BASE OF THE WALL UP. THE NUMBER OF STONE BLOCKS THAT CAN BE REMOVED AT ONCE IS AT THE DISCRETION OF THE MASON, WITH THE SAFETY OF THE WORKERS BEING THE PRIMARY CONCERN.
- IF AT ANY GIVEN TIME, EITHER THE MASON OR THE STRUCTURAL ENGINEER THINKS THAT TEMPORARY SHORING IS REQUIRED, SUITABLE OPTIONS SHALL BE DISCUSSED IN DETAIL BY BOTH PARTIES, AND THEN APPROVED IN WRITING BY BOTH PARTIES.
- IN THE ABSENCE OF A SOLUBLE SULPHATE TEST, THE CONCRETE MORTAR SHALL COMPLY WITH THE REQUIREMENTS FOR A CLASS S-1 EXPOSURE, WITH A MODIFIED MAXIMUM COARSE AGGREGATE SIZE; MAXIMUM WATER-TO-CEMENT RATIO OF 0.40, 56-DAY COMPRESSIVE STRENGTH OF 35 MPA, 5 MM MAXIMUM NOMINAL COARSE AGGREGATE SIZE, 4 TO 7 PERCENT AIR CONTENT, HS OR HSB TYPE CEMENT (TYPE 50); CURE CONCRETE AT NO LESS THAN 10°C FOR NO LESS THAN 7 DAYS OR THE TIME NECESSARY TO GAIN 70 PERCENT OF THE COMPRESSIVE CYLINDER STRENGTH.

REV.	DESCRIPTION	DATE
0	ISSUED FOR TENDER	21 JULY 2021

DC D.C. DECHKA CONSULTING ENGINEERS LIMITED
 27 Silverview Place N.W., Calgary, AB, T3B 3K5
 Phone: (403) 204 - 2234
 E-mail: dechka@telus.net

**PARKS CANADA - UPPER BANFF HOT SPRINGS
 STONE BLOCK RETAINING WALL UPGRADES**

GENERAL NOTES

PROJECT NUMBER:	21-153-01
DATE:	6 JULY 2021
SCALE:	AS SHOWN
DRAWN:	D.C.
CHECKED:	D.D.

DRAWING NUMBER:

S18

- THE CEMENT CONTENT AND WATER/CEMENT RATIO SHALL BE MINIMIZED, BUT NOT SO MUCH AS TO IMPEDE THE WORKABILITY OF THE MORTAR. WATER-REDUCING ADMIXTURES AND/OR SUPERPLASTICIZERS MAY BE USED TO REDUCE THE WATER/CEMENT RATIO.
- CALCIUM CHLORIDE, OR ANY ADMIXTURE FORMULATION CONTAINING CHLORIDE, SHALL NOT BE USED.
- ALL CONCRETE SHALL BE BATCHED ON SITE. THE SIZE OF EACH BATCH SHALL BE LIMITED TO NO MORE THAN WHAT CAN BE PLACED IN ITS FINAL POSITION WITHIN 90 MINUTES OF BATCHING.
- THE MORTAR SHALL BE PROTECTED FROM PREMATURE DRYING AND EXTREMES OF TEMPERATURE.
- COLD-WEATHER CONSTRUCTION IS NOT RECOMMENDED. HOWEVER, IN THE EVENT THAT THE CONTRACTOR CHOOSES TO WORK THROUGH THE WINTER MONTHS, THE MORTAR SHALL BE PROTECTED FROM FREEZING.
- IF THE AMBIENT TEMPERATURE IS EXPECTED TO FALL BELOW 10°C, THE CONTRACTOR SHALL PROVIDE HEATING AND/OR HOARDING IN ACCORDANCE WITH THE EXPOSURE CLASSIFICATION (7 DAYS). THE METHODS OF HOARDING AND HEATING THE CONCRETE SHALL BE REVIEWED AND APPROVED IN WRITING BY THE STRUCTURAL ENGINEER.
- FOR EVERY CUBIC METER OF MORTAR, THE CONTRACTOR SHALL RETAIN A CONCRETE TESTING AGENCY TO CAST AT LEAST THREE 4-INCH-DIAMETER BY 8-INCH-LONG CONCRETE CYLINDERS, TO BE USED FOR VERIFICATION OF THE COMPRESSIVE STRENGTH.
- THE TESTING AGENCY SHALL RECORD THE SLUMP AND LEVEL OF AIR ENTRAINMENT.

ASPHALT PAVEMENT:

- 1
- THE TOTAL AREA OF NEW ASPHALT PAVEMENT IS APPROXIMATELY 110 M².
 - THE ASPHALT PAVEMENT SHALL MEET THE CITY OF CALGARY SPECIFICATIONS FOR A 'TYPE B' MIX.
 - THE GRAVEL 'BASE' (BENEATH THE ASPHALT PAVEMENT) SHALL BE A LOCALLY AVAILABLE, WELL-GRADED, 'ROAD BASE' TYPE GRAVEL, WITH A 20 MM CRUSHED COARSE AGGREGATE, AND WHICH SHALL BE COMPACTED TO NO LESS THAN 98 PERCENT OF STANDARD PROCTOR DENSITY.
 - THE GRAVEL 'SUB-BASE' (BENEATH THE GRAVEL 'BASE') SHALL BE A LOCALLY AVAILABLE, WELL-GRADED, 'PIT RUN' TYPE GRAVEL, WITH A MAXIMUM 76 MM COARSE AGGREGATE SIZE, AND WHICH SHALL BE COMPACTED IN NO MORE THAN 150 MM LIFTS TO NO LESS THAN 98 PERCENT OF STANDARD PROCTOR DENSITY.
 - THE SURFACE OF THE NATIVE SOIL (BENEATH THE GRAVEL 'SUB-BASE') SHALL BE COMPACTED TO NO LESS THAN 95 PERCENT OF STANDARD PROCTOR DENSITY.

STRUCTURAL REVIEW:

- PRIOR TO THE INSTALLATION OF ANY OTHER STRUCTURAL ELEMENTS, OR ANY OTHER MATERIALS THAT MIGHT OBSTRUCT A VISUAL ASSESSMENT OF THE FINISHED PRODUCT, THE STRUCTURAL ENGINEER SHALL FIELD REVIEW THE INSTALLATION OF ALL STRUCTURAL ELEMENTS. THE CONTRACTOR SHALL GIVE THE STRUCTURAL ENGINEER A MINIMUM OF 48 HOURS NOTICE PRIOR TO THE TIME SCHEDULED FOR EACH INSPECTION.
- THE FIELD REVIEWS SHALL INCLUDE, BUT ARE NOT NECESSARILY LIMITED TO THE FOLLOWING:
 1. THE CONDITION OF THE INSIDE FACE OF THE STONE RETAINING WALL.
 2. THE REINFORCEMENT IN THE FOOTINGS.
 3. THE REINFORCEMENT IN EACH LIFT OF THE WALLS.
 4. THE DRAINAGE SYSTEM.



1
S19 TYP. 'SAND CHAIR' (AVAILABLE @ MOST HARDWARE STORES &/OR CONC. SUPPLY RETAIL OUTLETS).

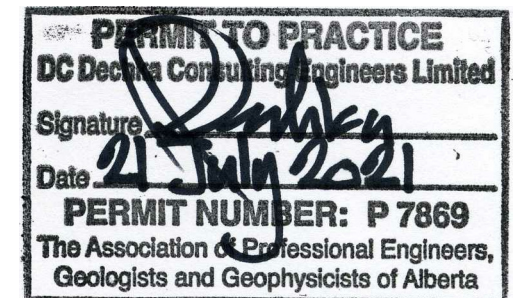
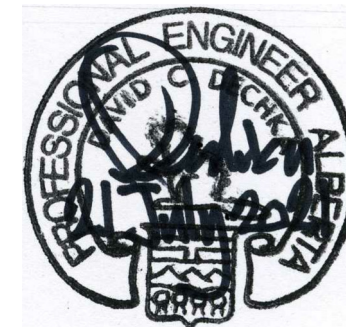

REV.	DESCRIPTION	DATE
1	ASPHALT REVISED	23 AUG. 2021
0	ISSUED FOR TENDER	21 JULY 2021

DC D.C. DECHKA CONSULTING ENGINEERS LIMITED
 27 Silverview Place N.W., Calgary, AB, T3B 3K5
 Phone: (403) 204 - 2234
 E-mail: dechka@telus.net

PARKS CANADA - UPPER BANFF HOT SPRINGS
 STONE BLOCK RETAINING WALL UPGRADES

GENERAL NOTES

PROJECT NUMBER:	21-153-01
DATE:	6 JULY 2021
SCALE:	AS SHOWN
DRAWN:	D.C.
CHECKED:	D.D.

DRAWING NUMBER:

S19