

Annex E - Standard REQUEST FOR BID (RFB)

No of Page/

N° de page _____

Public Works and
Government Services
CanadaTravaux publics et
Services gouvernementaux
Canada**RETURN BIDS TO:****RETOURNER LES SOUMISSIONS À:**

See Section 1.

Voir Section 1.

STANDARD REQUEST FOR BID**INVITATION À SOUMISSIONNER - STANDARD**

The Bidder offers to provide to Canada the goods, services or both listed in the bid solicitation in accordance with the conditions set out in the bid solicitation and the prices set out in the bid.

This bid solicitation is issued in accordance with the conditions of the Supply Arrangement E60PQ-140003/PQ.

Le soumissionnaire offre de fournir au Canada les biens, services ou les deux énumérés dans la demande de soumissions aux conditions prévues dans la demande de soumissions et aux prix indiqués dans la soumission.

Cette demande de soumissions est émise conformément aux conditions de l'arrangement en matière d'approvisionnement E60PQ-140003/PQ.

Solicitation No. - N° de la demande W3028-22TM04	Amendment No. - N° de modification
---	------------------------------------

Solicitation closes – La demande prend fin : at – à November/Novembre 09, 2021 on – le 2 :00pm EST	File No. - N° de dossier
---	--------------------------

Date of Solicitation – Date de la demande October 28, 2021
Address inquiries to – Adresser toute demande de renseignement à : See Section 2, Article 4.1. Voir Section 2, Article 4.1
Destination See Section 2, Annex A. Voir Section 2, Annexe A.

Instructions:

Municipal taxes are not applicable.

Unless otherwise specified in the bid solicitation, all prices quoted must be net prices in Canadian funds including Canadian customs duties, excise taxes, must be FOB, including all delivery charges to destination(s) as indicated. The amount for Applicable Taxes is to be shown as a separate item.

Instructions:

Les taxes municipales ne s'appliquent pas.

Sauf indication contraire dans la demande de soumissions, tous les prix indiqués doivent être des prix nets, en dollars canadiens, comprenant les droits de douane canadiens, la taxe d'accise et doivent être FAB, y compris tous frais de livraison à la (aux) destination(s) indiqué(s). Le montant des taxes applicables doit apparaître séparément.

Supplier Name and Address – Nom et adresse du fournisseur
Telephone No. - N° de téléphone Facsimile No. - N° de télécopieur
Name and title of person authorized to sign on behalf of supplier (type or print) Nom et titre de la personne autorisée à signer au nom du fournisseur (caractère d'impression)
Signature : _____ Date : _____

Section 1 – Invitation and Instructions to Bidders

Section 2 – Resulting Contract including a list of required goods and services

SECTION 1 – INVITATION AND INSTRUCTIONS TO BIDDERS

Step 1. For Tier 2 and Tier 3 only (If Tier 1, skip this step and proceed with step 2)

Step 2. Competitive or Non-Competitive

For competitive Requirements when more than one bid is received:

A bid must comply with the requirements of the bid solicitation and meet all mandatory technical evaluation criteria to be declared responsive. The responsive bid with the lowest evaluated price will be recommended for award of a contract.

For Competitive Requirements when only one bid is received:

The Bidder must provide the following information AFTER bid closing, if requested to do so by Canada:

- One or more of the following price justifications:
 1. a current published price list indicating the percentage discount available to Canada; or
 2. a copy of paid invoices for the like quality and quantity of the goods, services or both sold to other customers; or
 3. a price breakdown showing the cost of direct labour, direct materials, purchased items, engineering and plant overheads, general and administrative overhead, transportation, etc., and profit; or
 4. any other supporting documentation as requested by Canada.

Step 3. General or PSAB

Terms of the RFB:

This RFB is issued pursuant to the Supplier's Furniture for Workspaces Supply Arrangement (SA) that forms part of the series of SAs issued by PWGSC with the number E60PQ-140003/PQ. The terms and conditions in the Supplier's SA apply to and form part of this RFB. Bidders who submit a bid agree to be bound by those terms and conditions as well as the terms and conditions in this RFB.

The WTCM is the Workspaces Terms and Conditions Manual that contains all terms and conditions in full text that form part of individual RFBs under this SA.

The Bidder must provide the following information WITH the bid:

- The information requested by Canada in Annex A herein.

The Bidder must also provide the information at article 4 below at the time indicated in article 3.

Security Requirement:

1. Conditions
 - a. the Bidder must hold a valid organization security (VOS) clearance as indicated in Annex B;
2. For additional information on security requirements, bidders should refer to the Canadian Industrial Security Directorate (CISD), Industrial Program of Public Works and Government Services Canada (<http://ssi-iss.tpsgc-pwgsc.gc.ca/index-eng.html>) website.
3. The conditions in article 1 above must be met by the Bidder (the checked box applies):
 - a. by the closing date of the bid;
 - b. before the award of a contract. Bidders are reminded to obtain the required security clearance promptly. Any delay in the award of a contract to allow the successful bidder to obtain the required clearance will be at the entire discretion of the Contracting Authority.
4. Bidders are to supply the following information, as a minimum, to demonstrate compliance with the Security Requirement.
 - a. The Bidder's valid VOS clearance number issued by CISD;

Bid Evaluation

An evaluation team composed of representatives of Canada will evaluate the bids.

RFB Issued by:	
Identified User's (IU) Department/Agency/Crown Corporation: Contact for this RFB:	See Section 2, article 4.1 below.
RFB Closing - Submit Bid: Bids must be submitted on the date and at the time indicated below.	
By no later than date and time:	a. November 09, 2021 b. 2:00pm EST
To physical location (if applicable)	Canadian Forces Joint Signal Regiment 20 Red Patch Ave Building E-37 Kingston, ON, K&K 7B4
To e-mail address (if applicable)	Terry.Merritt@forces.gc.ca
RFB Enquiries	
Unless a different period is listed in the adjacent column, Bidders may submit enquires about the RFB to the Contracting Authority two business days prior to the RFB closing date. Enquiries received after the timeline indicated may not be answered.	

SECTION 2 - RESULTING CONTRACT CLAUSES

1.	Terms and Conditions of the Contract	
	The terms and conditions of Parts 6B and 6C of the Supplier's SA within the series E60PQ-140003/PQ apply to and form part of this Contract.	
2.	Security Requirement (the checked article applies)	
2.1	The applicable security requirement(s) is (are) set out in the Security Requirement Check List attached as Annex B of this contract. The Contractor must fulfill the security requirements by meeting the terms below.	
a.		Contractor may be escorted; possession of security clearance not required. Contractor personnel MAY NOT ENTER NOR PERFORM WORK ON sites where PROTECTED or CLASSIFIED information or assets are kept, without an escort provided by the department or agency for which the work is being performed.
b.	<input checked="" type="checkbox"/>	Possession of security clearance(s) is required. The Contractor must meet the security clearance requirements contained in the clausing in Annex B herein.
c.		There is no security requirement associated with this contract.
3.	Requirement	
3.1	The Contractor must perform the Work listed in Annex A herein.	
4.	Authorities	
4.1	Contracting Authority (IU)	
	Name:	Terry Merritt
	Title:	Contract Officer
	Department/Agency/Crown Corporation:	Department of National Defence
	Address:	2 Lance St Kingston, ON

		K7K 7B4
	Telephone No.:	613-541-5010 Ext 4067
	E-mail address:	Terry.Merritt@forces.gc.ca
4.2	<p>Project Authority <i>[To be completed at contract award]</i></p> <p><i>The Project Authority (PA) is the representative of the department or agency for whom the Work is being carried out under the Contract including the provision to approve the authority to proceed for delivery and installation and is responsible for all matters concerning the technical content of the Work under the Contract.</i></p> <p><i>In addition, the PA is also responsible for ensuring that the Supplier's employees and subcontractors requiring access to the site adhere to the allocated time for the Supplier to access the site to deliver and install the furniture in accordance with the master schedule held by the General Contractor (a representative of Canada or a service provider(s) under contract with the Government of Canada).</i></p>	
	Name:	
	Title:	
	Department/Agency/Crown Corporation:	
	Address:	
	Telephone No.:	
	E-mail address:	
4.3	<p>Contractor's Representative</p> <p>As set out in Annex A, Table 9 below.</p>	
5.	<p>Method of Payment</p> <p>The checked box applies. If the Contractor's SA indicates acceptance for payment by credit card, that method may be used in conjunction with the following.</p>	
	<input type="checkbox"/>	Single Payment
	<input checked="" type="checkbox"/>	Multiple Payment
6.	<p>Invoicing <i>(optional)</i></p> <p>Further to the Invoicing terms of the WTCM document, the Contractor will deliver the original and one copy of the invoice to the following address for certification and payment:</p> <p>Name of the organization and contact: <i>[To be completed at contract award]</i></p> <p>Address:</p>	
7.	<p>Defence Contract. This clause applies if the box below is checked.</p> <p><input type="checkbox"/> The Contract is a defence contract within the meaning of the Defence Production Act, R.S.C. 1985, c. D-1.</p>	

**ANNEX A
REQUIREMENT and BASIS OF PAYMENT**

1. Category Selection

<p>Combined Categories Rule:</p> <p>For reasons of compatibility, the following categories will be combined for evaluation and contract award purposes:</p> <p>The rule only applies to the categories below that are checked. The unchecked categories will be evaluated separately and may be awarded to multiple suppliers;</p> <p><input checked="" type="checkbox"/> Category 1</p> <p><input checked="" type="checkbox"/> Category 2</p> <p><input checked="" type="checkbox"/> Category 5</p> <p>* Exception: when using the Cat 1, 2, 5 combined categories rule, IU's may calculate the percentage of NSA product allowed (as defined in their solicitation document) against the total quantity of the combined categories.</p>
<p>Design Upgrade Rule:</p> <p>The IU may exercise an option to upgrade products up to 20% of each Category product total before Applicable Taxes after contract award.</p> <p>The Design Upgrade amount is used at the discretion of the Project Authority (PA) prior to the manufacturing/ordering of the products, the PA will provide the Contractor with a written notice of Canada's Design Upgrade choices for each of the product(s) to be upgraded. The Contractor will provide the pricing of the upgraded product(s) to a maximum of 20% of each Category Contract Price of Table 8. The Contracting Authority will issue an amendment to the contract with the Design Upgrades and pricing.</p> <p>The Supplier certifies that all the Design Upgraded products offered will conform to all specifications and meet the testing requirements detailed in the Specifications of the Supply Arrangement.</p> <p>Design Upgrade: is the process of replacing a product with a more innovative or enhanced version of the same product.</p>
<p>NSA:</p> <p>NSA products can be incorporated in the RFB and must not exceed 30% of the firm quantity by category. NSA items must be added to the category that is most closely related and must be generic.</p>

The requirement includes the following category (ies) of work:

a. Category 1 – Interconnecting Panels and Freestanding Systems

Category 1a – Interconnecting Panels (Refer to Annex C)

Category 1b – Supporting components and freestanding furniture

RULE: Metal Storage

Identified Users may procure metal storage products forming part of Category 1 when the metal storage products will be part of a requirement for a workstation(s)/work point(s). If this rule does not apply, Category 3 must be used for the metal storage products forming part of this category.

b. Category 2 – Freestanding Height Adjustable Desk / Table Products

c. Category 3 – Metal Filing and Storage Cabinets

RULE: High Storage Products

Identifying the maximum height of the Personal Storage Towers, Wardrobes and Storage Cabinets is acceptable as per 6B. 4.1 of the SA.

Maximum Height for product #(s) _____ at article 3 of this Annex is _____.

d. Category 4 – Wood Veneer – Freestanding Products

e. Category 5 – Ancillary and Lighting Products

f. Category 6 - Support Space – Collaborative Furniture

RULE: Category 6 can be further subdivided by space or like product in order to increase or allow competition. Space is defined as a location available for a particular purpose such as a meeting room space or a collaborative space. Like products are defined as products with similar design and construction. If NSA products form part of the requirement, the IU must validate the 30% NSA prior to subdividing the category. NSA products can be added to any subdivide or in its own subdivide.

The IU must identify how Category 6 will be subdivided in the Product Table for Category 6.

g. NSA Product(s) – Category(ies): _____

2. Product and Pricing Tables

Site Inspection Date: To be coordinated with Project Authority after contract award. (Refer to Annex A article 4 of the SA for Site Inspection and Documentation instructions.)

INSTRUCTIONS TO BIDDERS: Bidders are to complete Sections B of the tables identified by the IU in this article as well as Tables 8 and 9. **Bidders must provide a complete product offering for each category, or CAT 6 sub-divide they wish to submit a bid in order to be compliant.**

****Refer to article 6A.7 for instructions on how to submit products that are not approved in product listing.****

In a resulting contract, the term “Bid” means the Supplier’s commitment, the term “Bidder” means “Contractor”.

Product Category (ies): _1, 2 and 5__

Table 1 – Product Table

Section A - IU REQUIREMENT				Section B – SUPPLIER’S BID		
#	GoCUID	Description of Product <i>(Additional product details may be inserted, if required as per 6B. 4.1 of the SA)</i>	Qty	Supplier Part Number	Firm Unit Price** \$	Extended Total [Qty x Price] \$
Category 1A						
1		Conventional Panel Seated Privacy Height with Add On Non-Powered 36" x 36" Qty 37				\$
2		Conventional Panel Seated Privacy Height with Add On Powered 36" X 36" Qty 9				
3		Conventional Panel Seated Privacy Height with Add On Non-Powered 36" X 24" Qty 3				
4		Symmetric Panel Seated Privacy Height with Add On Non-Powered 15" X 36" Qty 43				
5		Symmetric Panel Seated Privacy Height with Add On Non-Powered 15" X 24" Qty 3				
Category 1B						
6	1BFFHREL24L48WN	Rectangle Worksurface with scallop 24"d X 48"w Item 87	9		\$	\$
7	1BSBBMCAA1524XKXX	Pedestal, Box File 22" Item 51	9		\$	\$
Category 2						
8	2WSSREXXL24L72BELXX	Individual Height, Adjustable Work Surfaces, Sit Stand, Electric Item 24	9		\$	\$
Category 5						
9	5M0ADURMGRMMTX	Monitor Arms , Duel, Standard Edge Clamp Item 12	9		\$	\$
10	5PMOWKSMTACUSBX	Power Station, 3Power + 2 USB + 0 Data. Desk Edge Clamp Item 20	9		\$	\$
11	5CPSUNWKSXXXXXXX	CPU Holder, Retractable, Swivel, No Lock Item 7	9			
NSA products (must not exceed 30% of the firm quantity by category)						
The Supplier signs, and certifies that all the NSA products offered will conform to all specifications and meet the testing requirements detailed at Annex D.						
Section A - IU REQUIREMENT				Section B – SUPPLIER’S BID		

#	NSA Product(s) Description	Qty	Supplier Part Number	Firm Unit Price** \$	Extended Total [Qty x Price] \$
12	Rectangular Countertop 15"d X 36"w Manager's Desk Finishes <ul style="list-style-type: none"> Desk surface: wood grain high pressure laminate with coordinating laminate edge band 	3		\$	\$
13	4-Port Faceplate, fit's standard modular furniture Grey	9		\$	\$
Add more rows if necessary.			Product Total		\$

Table 2 - Delivery

Section A - IU REQUIREMENT				Section B – SUPPLIER'S BID	
Product Item # from Table 1	Location	Desired Date** (Y/M/D)	Desired Time: Normal Business Hours Or Outside Normal Business Hours *	Supplier will supply and deliver as per below**	Firm Lot Price \$
1 to 13	Building E-37, 2 nd Floor, Rm 269 20 Red Patch Avenue Kingston, ON, K7K 7B4	21/03/07 or an earlier time if requested. We have a large warehouse.	*Normal Business Hours	_____ : weeks <i>Standard Lead time is between 6-10 weeks for furniture delivery and installation.</i>	\$
*Normal Business Hours 8:00 – 17:00, as per SA, Annex A, article 5				Delivery Total:	\$
**The Project Authority (PA) will provide the supplier the authority to proceed prior to the finalized delivery date taking into consideration the delivery time provided by the supplier. Canada will not be responsible if the supplier chooses to proceed without the PA authorization.					

Table 3 – Installation

Section A - IU REQUIREMENT				Section B – SUPPLIER'S BID	
Product Item # from Table 1	Location	Desired Date (Y/M/D)**	Desired Time: Normal Business Hours Or	Supplier will install as per below**	Firm Lot Price \$

			Outside Normal Business Hours *		
1 to 9	Building E-37, 2 nd Floor, Rm 269 20 Red Patch Avenue Kingston, ON, K7K 7B4	21/03/07	*Normal Business Hours	_____ : weeks from date of supply and delivery <i>Standard Lead time is between 6-10 weeks for furniture delivery and installation.</i>	\$
*Normal Business Hours 8:00 – 17:00, as per SA, Annex A, article 5 **The Project Authority (PA) will provide the supplier the authority to proceed prior to the finalized installation date taking into consideration the installation time provided by the supplier. Canada will not be responsible if the supplier chooses to proceed without the PA authorization.				Installation Total:	\$

Table 4 – Optional Product ☒ Not Applicable

Table 5 – Optional Delivery ☒ Not Applicable

Table 6 – Optional Installation ☒ Not Applicable

Table 7 – Standard Finishes and Canada’s Facilities to Accommodate the Delivery and Certifications

1.	Standard Finishes	
1.1	<p>IU is to consult the Supplier’s Website identified in Part 6A of the SA to view the available finishes.</p> <p>Within ten business days of the contract award, the Project Authority will provide the Contractor with a written notice of Canada’s finish choices for each of the product(s) in Annex A.</p> <p>The Contractor will deliver the products corresponding to Canada’s choice of specific finishes(s). No additional charge will be applied to Canada.</p>	
2.	Canada’s Facilities to Accommodate the Delivery	
	<p><i>The Supplier’s employees and subcontractors requiring access to the site must adhere to the health and safety plans established for the site, in addition to any laws in effect in the jurisdiction where the work is being performed.</i></p> <p><i>During the period of the contract, a representative of Canada or a service provider(s) under contract with the Government of Canada may request the list of employees and subcontractors requiring access to the site to perform the work and their security statuses. Information must be provided in the timeframe prescribed in order to ensure that the supply, delivery and installation of the furniture aligns with the master schedule.</i></p>	
2.1	Loading Dock/Location	
A	Location	Building E-37 20 Red Patch Avenue Kingston, ON, K7K 7B4 The loading zone is located at the west bay door. Normal hours of operation are from 7:30am to 3:30pm
B	Dock	Only floor access no dock
C	Lift	There is no lift
D	Door	The door is 14’ wide and 14’ high
E	Freight Elevator	No there is a Personnel elevator that also can be used for freight
F	Other (specify, if any)	We have a forklift to assist.
3.	Continuance of Certifications	
	The Bidder certifies that by submitting a bid in response to the RFB, the Bidder, and any of the Bidder’s members if the Bidder is a Joint Venture, continues to comply with all of the following certifications listed in Parts 6A and 6B of the Bidder’s SA for Work Spaces.	

	Canada may request copies of environmental certification(s) prior to contract award within a time period specified by the Identified User.
3.1	Integrity Provisions
3.2	Federal Contractor's Program for Employment Equity
3.4	Product Conformance
3.5	Price Certification (In accordance with the SA, Part 6B)

Table 8 - Bid Evaluation and Contract Total for CATEGORY 1, 2 and 5 (Canada may complete if not completed by the Bidder)

1	Firm Product Total (Table 1)	\$
2	Firm Delivery Total (Table 2)	\$
3	Firm Installation Total (Table 3)	\$
4	Optional Product Total (Table 4) <i>(Applicable if Option is exercised)</i>	n/a
5	Optional Delivery Total (Table 5) <i>(Applicable if Option is exercised)</i>	n/a
6	Optional Installation Total (Table 6) <i>(Applicable if Option is exercised)</i>	n/a
7	Hardware Total as per article 1.5 of Annex A-1 of SA <i>(if Applicable)</i>	\$
8	Total Evaluated (Bid) Price* (1 + 2 + 3 + 4 + 5 + 6+ 7) [to be removed at contract award]	\$
9	Contract Price(1+2+3+7): [applicable at contract award only]	\$
10	Applicable Tax(es): [applicable at contract award only]	\$
11	Total Estimated Cost (9+10): [applicable at contract award only]	\$

* Applicable taxes extra.

Table 9 – Bidder's Authorized Representative

1.	Bidder's Authorized Representative for the Bid and the Contract	
	Name:	Telephone:
		E-Mail:
		Other:

**ANNEX B
SECURITY REQUIREMENTS**

The security requirements set out in the attached Security Requirements Check List (SRCL) and in the terms below apply to and form part of the Contract.

Security requirement for Canadian supplier: Public Works and Government Services Canada (PWGSC) file #
Common professional services security requirement check list #2

1. The contractor/offeror must, at all times during the performance of the contract/standing offer, hold a valid designated organization screening (DOS), issued by the Contract Security Program (CSP), Public Works and Government Services Canada (PWGSC)
2. The contractor/offeror personnel requiring access to sensitive work site(s) must each hold a valid reliability status, granted or approved by the CSP, PWGSC
3. Subcontracts which contain security requirements are not to be awarded without the prior written permission of the CSP, PWGSC 4. The contractor/offeror must comply with the provisions of the:
 - a. Security Requirements Check List and security guide (if applicable), attached at Annex
 - b. Contract Security Manual (latest edition)



Government of Canada / Gouvernement du Canada

Contract Number / Numéro du contrat W3028-22TM04
Security Classification / Classification de sécurité Unclassified

**SECURITY REQUIREMENTS CHECK LIST (SRCL)
LISTE DE VÉRIFICATION DES EXIGENCES RELATIVES À LA SÉCURITÉ (LVERS)**

PART A - CONTRACT INFORMATION / PARTIE A - INFORMATION CONTRACTUELLE		
1. Originating Government Department or Organization / Ministère ou organisme gouvernemental d'origine Department of National Defence		2. Branch or Directorate / Direction générale ou Direction CJOC/CFJSR
3. a) Subcontract Number / Numéro du contrat de sous-traitance	3. b) Name and Address of Subcontractor / Nom et adresse du sous-traitant	
4. Brief Description of Work / Brève description du travail Delivery and Installation of 9 Work Stations		
5. a) Will the supplier require access to Controlled Goods? Le fournisseur aura-t-il accès à des marchandises contrôlées?		<input checked="" type="checkbox"/> No / Non <input type="checkbox"/> Yes / Oui
5. b) Will the supplier require access to unclassified military technical data subject to the provisions of the Technical Data Control Regulations? Le fournisseur aura-t-il accès à des données techniques militaires non classifiées qui sont assujetties aux dispositions du Règlement sur le contrôle des données techniques?		<input checked="" type="checkbox"/> No / Non <input type="checkbox"/> Yes / Oui
6. Indicate the type of access required / Indiquer le type d'accès requis		
6. a) Will the supplier and its employees require access to PROTECTED and/or CLASSIFIED information or assets? Le fournisseur ainsi que les employés auront-ils accès à des renseignements ou à des biens PROTÉGÉS et/ou CLASSIFIÉS? (Specify the level of access using the chart in Question 7. c) (Préciser le niveau d'accès en utilisant le tableau qui se trouve à la question 7. c)		<input checked="" type="checkbox"/> No / Non <input type="checkbox"/> Yes / Oui
6. b) Will the supplier and its employees (e.g. cleaners, maintenance personnel) require access to restricted access areas? No access to PROTECTED and/or CLASSIFIED information or assets is permitted. Le fournisseur et ses employés (p. ex. nettoyeurs, personnel d'entretien) auront-ils accès à des zones d'accès restreintes? L'accès à des renseignements ou à des biens PROTÉGÉS et/ou CLASSIFIÉS n'est pas autorisé.		<input type="checkbox"/> No / Non <input checked="" type="checkbox"/> Yes / Oui
6. c) Is this a commercial courier or delivery requirement with no overnight storage? S'agit-il d'un contrat de messagerie ou de livraison commerciale sans entreposage de nuit?		<input checked="" type="checkbox"/> No / Non <input type="checkbox"/> Yes / Oui
7. a) Indicate the type of information that the supplier will be required to access / Indiquer le type d'information auquel le fournisseur devra avoir accès		
Canada <input type="checkbox"/>	NATO / OTAN <input type="checkbox"/>	Foreign / Étranger <input type="checkbox"/>
7. b) Release restrictions / Restrictions relatives à la diffusion		
No release restrictions / Aucune restriction relative à la diffusion <input type="checkbox"/>	All NATO countries / Tous les pays de l'OTAN <input type="checkbox"/>	No release restrictions / Aucune restriction relative à la diffusion <input type="checkbox"/>
Not releasable / À ne pas diffuser <input type="checkbox"/>		
Restricted to: / Limité à: <input type="checkbox"/> Specify country(ies): / Préciser le(s) pays:	Restricted to: / Limité à: <input type="checkbox"/> Specify country(ies): / Préciser le(s) pays:	Restricted to: / Limité à: <input type="checkbox"/> Specify country(ies): / Préciser le(s) pays:
7. c) Level of information / Niveau d'information		
PROTECTED A / PROTÉGÉ A <input type="checkbox"/>	NATO UNCLASSIFIED / NATO NON CLASSIFIÉ <input type="checkbox"/>	PROTECTED A / PROTÉGÉ A <input type="checkbox"/>
PROTECTED B / PROTÉGÉ B <input type="checkbox"/>	NATO RESTRICTED / NATO DIFFUSION RESTREINTE <input type="checkbox"/>	PROTECTED B / PROTÉGÉ B <input type="checkbox"/>
PROTECTED C / PROTÉGÉ C <input type="checkbox"/>	NATO CONFIDENTIAL / NATO CONFIDENTIEL <input type="checkbox"/>	PROTECTED C / PROTÉGÉ C <input type="checkbox"/>
CONFIDENTIAL / CONFIDENTIEL <input type="checkbox"/>	NATO SECRET / NATO SECRET <input type="checkbox"/>	CONFIDENTIAL / CONFIDENTIEL <input type="checkbox"/>
SECRET / SECRET <input type="checkbox"/>	COSMIC TOP SECRET / COSMIC TRÈS SECRET <input type="checkbox"/>	SECRET / SECRET <input type="checkbox"/>
TOP SECRET / TRÈS SECRET <input type="checkbox"/>		TOP SECRET / TRÈS SECRET <input type="checkbox"/>
TOP SECRET (SIGINT) / TRÈS SECRET (SIGINT) <input type="checkbox"/>		TOP SECRET (SIGINT) / TRÈS SECRET (SIGINT) <input type="checkbox"/>



Government of Canada
Gouvernement du Canada

Contract Number / Numéro du contrat

W3028-22TM04

Security Classification / Classification de sécurité
Unclassified

PART A (continued) / PARTIE A (suite)

8. Will the supplier require access to PROTECTED and/or CLASSIFIED COMSEC information or assets?
Le fournisseur aura-t-il accès à des renseignements ou à des biens COMSEC désignés PROTÉGÉS et/ou CLASSIFIÉS? No / Non Yes / Oui

If Yes, indicate the level of sensitivity:

Dans l'affirmative, indiquer le niveau de sensibilité :

9. Will the supplier require access to extremely sensitive INFOSEC information or assets?
Le fournisseur aura-t-il accès à des renseignements ou à des biens INFOSEC de nature extrêmement délicate? No / Non Yes / Oui

Short Title(s) of material / Titre(s) abrégé(s) du matériel :

Document Number / Numéro du document :

PART B - PERSONNEL (SUPPLIER) / PARTIE B - PERSONNEL (FOURNISSEUR)

10. a) Personnel security screening level required / Niveau de contrôle de la sécurité du personnel requis

- | | | | |
|---|---|---|--|
| <input checked="" type="checkbox"/> RELIABILITY STATUS
COTE DE FIABILITÉ | <input type="checkbox"/> CONFIDENTIAL
CONFIDENTIEL | <input type="checkbox"/> SECRET
SECRET | <input type="checkbox"/> TOP SECRET
TRÈS SECRET |
| <input type="checkbox"/> TOP SECRET-SIGINT
TRÈS SECRET - SIGINT | <input type="checkbox"/> NATO CONFIDENTIAL
NATO CONFIDENTIEL | <input type="checkbox"/> NATO SECRET
NATO SECRET | <input type="checkbox"/> COSMIC TOP SECRET
COSMIC TRÈS SECRET |
| <input type="checkbox"/> SITE ACCESS
ACCÈS AUX EMPLACEMENTS | | | |

Special comments:

Commentaires spéciaux :

NOTE: If multiple levels of screening are identified, a Security Classification Guide must be provided.

REMARQUE : Si plusieurs niveaux de contrôle de sécurité sont requis, un guide de classification de la sécurité doit être fourni.

10. b) May unscreened personnel be used for portions of the work?
Du personnel sans autorisation sécuritaire peut-il se voir confier des parties du travail? No / Non Yes / Oui

If Yes, will unscreened personnel be escorted?

Dans l'affirmative, le personnel en question sera-t-il escorté? No / Non Yes / Oui

PART C - SAFEGUARDS (SUPPLIER) / PARTIE C - MESURES DE PROTECTION (FOURNISSEUR)

INFORMATION / ASSETS / RENSEIGNEMENTS / BIENS

11. a) Will the supplier be required to receive and store PROTECTED and/or CLASSIFIED information or assets on its site or premises?
Le fournisseur sera-t-il tenu de recevoir et d'entreposer sur place des renseignements ou des biens PROTÉGÉS et/ou CLASSIFIÉS? No / Non Yes / Oui

11. b) Will the supplier be required to safeguard COMSEC information or assets?
Le fournisseur sera-t-il tenu de protéger des renseignements ou des biens COMSEC? No / Non Yes / Oui

PRODUCTION

11. c) Will the production (manufacture, and/or repair and/or modification) of PROTECTED and/or CLASSIFIED material or equipment occur at the supplier's site or premises?
Les installations du fournisseur serviront-elles à la production (fabrication et/ou réparation et/ou modification) de matériel PROTÉGÉ et/ou CLASSIFIÉ? No / Non Yes / Oui

INFORMATION TECHNOLOGY (IT) MEDIA / SUPPORT RELATIF À LA TECHNOLOGIE DE L'INFORMATION (TI)

11. d) Will the supplier be required to use its IT systems to electronically process, produce or store PROTECTED and/or CLASSIFIED information or data?
Le fournisseur sera-t-il tenu d'utiliser ses propres systèmes informatiques pour traiter, produire ou stocker électroniquement des renseignements ou des données PROTÉGÉS et/ou CLASSIFIÉS? No / Non Yes / Oui

11. e) Will there be an electronic link between the supplier's IT systems and the government department or agency?
Disposera-t-on d'un lien électronique entre le système informatique du fournisseur et celui du ministère ou de l'agence gouvernementale? No / Non Yes / Oui



Government of Canada
Gouvernement du Canada

Contract Number / Numéro du contrat W3028-22TM04
Security Classification / Classification de sécurité Unclassified

PART C - (continued) / PARTIE C - (suite)

For users completing the form **manually** use the summary chart below to indicate the category(ies) and level(s) of safeguarding required at the supplier's site(s) or premises.

Les utilisateurs qui remplissent le formulaire **manuellement** doivent utiliser le tableau récapitulatif ci-dessous pour indiquer, pour chaque catégorie, les niveaux de sauvegarde requis aux installations du fournisseur.

For users completing the form **online** (via the Internet), the summary chart is automatically populated by your responses to previous questions.

Dans le cas des utilisateurs qui remplissent le formulaire **en ligne** (par Internet), les réponses aux questions précédentes sont automatiquement saisies dans le tableau récapitulatif.

SUMMARY CHART / TABLEAU RÉCAPITULATIF

Category Catégorie	PROTECTED PROTÉGÉ			CLASSIFIED CLASSIFIÉ			NATO				COMSEC					
	A	B	C	CONFIDENTIAL CONFIDENTIEL	SECRET	TOP SECRET TRÈS SECRET	NATO RESTRICTED NATO DIFFUSION RESTREINTE	NATO CONFIDENTIAL NATO CONFIDENTIEL	NATO SECRET	COSMIC TOP SECRET COSMIC TRÈS SECRET	PROTECTED PROTÉGÉ			CONFIDENTIAL CONFIDENTIEL	SECRET	TOP SECRET TRÈS SECRET
											A	B	C			
Information / Assets Renseignements / Biens Production																
IT Media / Support TI																
IT Link / Lien électronique																

12. a) Is the description of the work contained within this SRCL PROTECTED and/or CLASSIFIED?
La description du travail visé par la présente LVERS est-elle de nature PROTÉGÉE et/ou CLASSIFIÉE? No / Non Yes / Oui

If Yes, classify this form by annotating the top and bottom in the area entitled "Security Classification".
Dans l'affirmative, classifiez le présent formulaire en indiquant le niveau de sécurité dans la case intitulée « Classification de sécurité » au haut et au bas du formulaire.

12. b) Will the documentation attached to this SRCL be PROTECTED and/or CLASSIFIED?
La documentation associée à la présente LVERS sera-t-elle PROTÉGÉE et/ou CLASSIFIÉE? No / Non Yes / Oui

If Yes, classify this form by annotating the top and bottom in the area entitled "Security Classification" and indicate with attachments (e.g. SECRET with Attachments).
Dans l'affirmative, classifiez le présent formulaire en indiquant le niveau de sécurité dans la case intitulée « Classification de sécurité » au haut et au bas du formulaire et indiquez qu'il y a des pièces jointes (p. ex. SECRET avec des pièces jointes).

Signature page was intentionally excluded from the RFB

**ANNEX C
FLOOR PLAN(S)**

INSTRUCTIONS TO BIDDERS:

For Category 1a products, the Bidders must provide:

- a) Completed floor plan(s) with proposed SA approved products;*
- b) A product listing of proposed SA approved products offered at floor plan(s).
As a minimum the product listing must include the following information:
 - Supplier part numbers including NSA products forming part of this category;*
 - brief product descriptions;*
 - quantities;*
 - firm unit prices.**

****** Products from categories other than Category 1a shown on floor plan are for information purposes only******

By submitting a bid, the Bidder certifies that their submission includes all components and quantities for Category 1a, in accordance with the floor plans, panel details, panel matrices and/or workstation layouts stipulated in Annex C.

****At contract award, "By submitting a bid, the Bidder" becomes "The Contractor".***

Category 1a Requirement:

- 1) Floor Plan(s) *Also as an Attachment***

DEPARTMENT OF NATIONAL DEFENCE
NEW WORKSTATIONS
 ADDRESS: DND KINGSTON - ENCLOSED WORKSTATIONS (38345)

SCOPE OF WORK
 NEW WORKSTATIONS (x6); NEW MANAGER WORKSTATIONS (x3)

DESCRIPTION	QTY	DESCRIPTION	QTY
WORKSTATIONS (x6):		MANAGERS (x3):	
51"H PANELS		51"H PANELS w/ 36"H COUNTER	
24"D x 72"W HA TABLE	01	24"D x 72"W HA TABLE	01
24"D x 47" W RETURN	01	24"D x 47" W RETURN	01
BBF PEDESTAL	01	BBF PEDESTAL	01
DUAL MONITOR ARM	01	DUAL MONITOR ARM	01
POWER MODULE	01	POWER MODULE	01
CPU HOLDER (U/S OF DESK)	01	CPU HOLDER (U/S OF DESK)	01

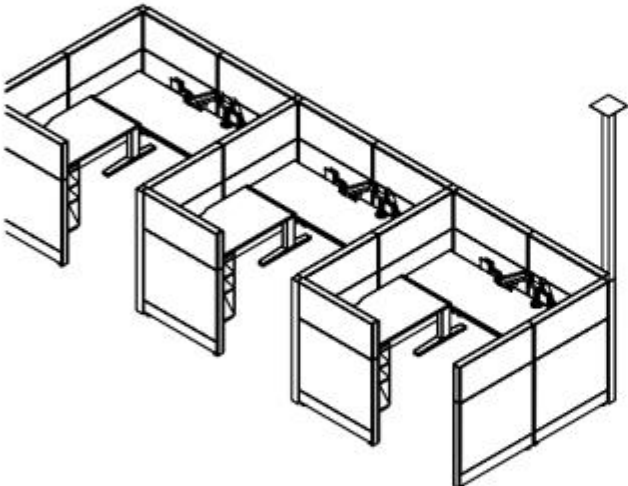
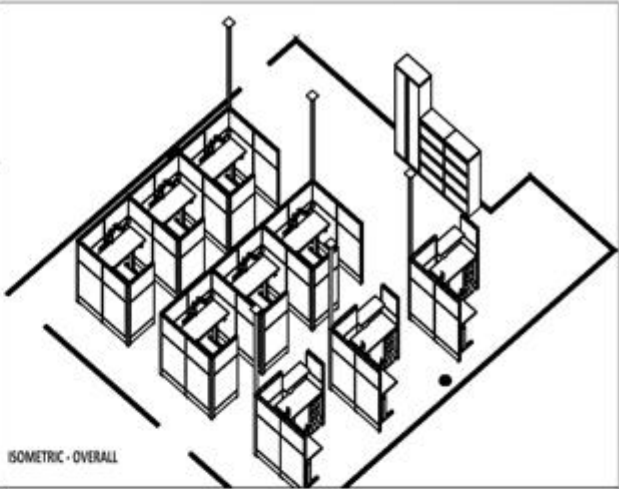

ISOMETRIC VIEWS - WORK STATIONS

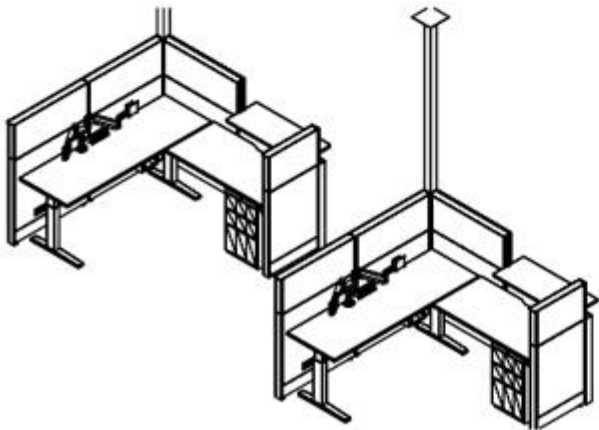

ISOMETRIC VIEWS - MANAGER STATIONS

Panel Details

- a. All required panel heights: *Seated Privacy Add-on Height*;
- b. When power is required, the power is located below work surface height; should a grouping of workstation types include shared panels and one side is identified as powered and the other side is non-powered, those panels affected must be powered.
- c. Type of power feed: *Power Pole*.

2) Panel Matrix or Workstation Layout

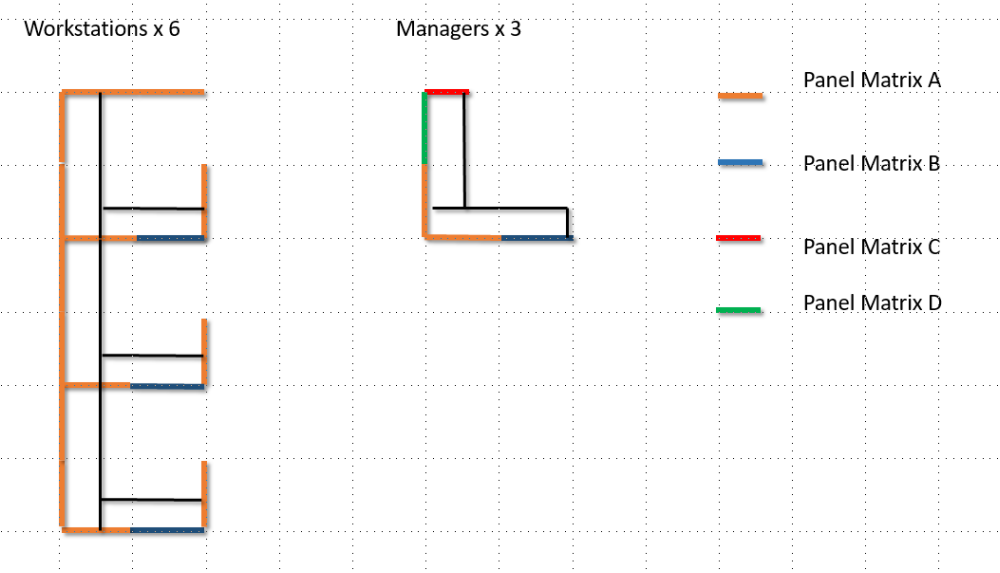

a. Panel Matrix

Panel Matrix

A

Panel Matrix: All fabric
 Seated Privacy Add-on Height

<i>upper element 1</i> Fabric / tissu	<i>upper element 2</i> Fabric / tissu
<i>lower element 1</i> Fabric / tissu	<i>lower element 2</i> Fabric / tissu

B

Panel Matrix: All Fabric
 Seated Privacy Add-on Height
 Single Sided Power

<i>upper element 1</i> Fabric / tissu	<i>upper element 2</i> Fabric / tissu
<i>lower element 1</i> Fabric / tissu	<i>lower element 2</i> Fabric / tissu Cut-out(s) for Power & Data, Fabric <i>Below Surface</i>
Side 1	Side 2

C

Panel Matrix:, All Fabric
 Seated Privacy Add-on Height
Managers Desk

<i>upper element 1</i> Fabric / tissu	<i>upper element 2</i> Fabric / tissu
<i>lower element 1</i> Fabric / tissu	<i>lower element 2</i> Fabric / tissu
Side 1	Side 2

D

Panel Matrix:, All Fabric
 Seated Privacy Add-on Height
 With Transactional Surface
Managers Desk

<i>lower element 1</i> Fabric / tissu	<i>lower element 2</i> Fabric / tissu
Side 1	Side 2

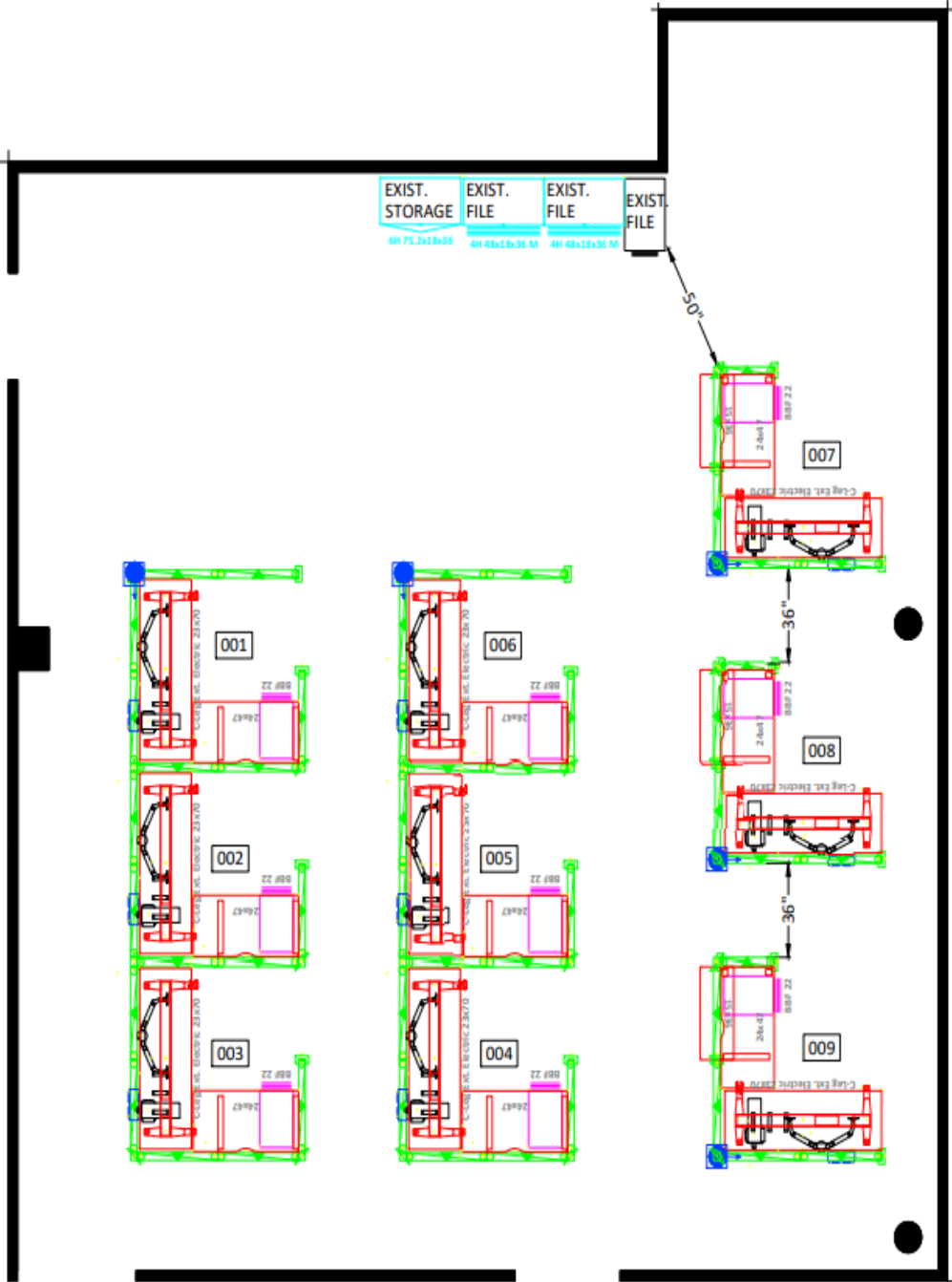

PLAN VIEW
SCALE: 3/8"=1'-0"

ANNEX D
Additional Specifications, Certifications

This Annex includes the additional Specifications, Certifications associated with NSA product. *(if applicable)* forming part of the requirement.

1. Specifications

The NSA products for this requirement must be tested and meet the performance Testing Requirements found at ANNEX A-1 and A-2 of the Supply Arrangement.

2. Certifications

.1 NSA Product Conformance

2.1 NSA Product Conformance *(Required precedent to Issuance of a contract)*

The Supplier certifies that all the NSA products offered will conform to all specifications indicated in Annex A and D of the RFB, and meet the testing and performance requirements found at ANNEX A-1 and A-2 of the Supply Arrangement, as applicable.

Supplier's Signature

Date

NSA Product Conformance Certification *(applies after contract award)*

The Supplier warrants that the NSA Product Conformance Certification submitted by the Supplier with its bid is accurate and complete. The Supplier must keep proper records and documentation relating to the NSA product conformance and the testing requirements in this Annex, as applicable. The Supplier must not, without obtaining the prior written consent of the SAA, dispose of any such records or documentation until the expiration of the Contract or the expiry date of the Warranty, whichever is later. All such records and documentation must at all times during the retention period be open to audit, inspection and examination by the representatives of Canada, who may make copies and take extracts.

In addition, the Supplier must provide representatives of the SAA access to all locations where any part of the Work is being performed at any time during working hours. Representatives of the SAA may examine and test the Work as they see fit. The Supplier must provide all assistance and access to facilities, test pieces, samples and documentation that the representatives of the SAA may reasonably require for the carrying out of the inspection, which may also include the submission of test reporting documentation as listed in Annex A and D. The Supplier must forward such test pieces, samples and/or documentation that may also include letters of certification from the laboratories to such person or location as the representatives of the SAA specifies.

CONTRACT FIRST PAGE

IU may use this page as page one at contract award. Attach Section 2 of the RFB including Annex A and, if applicable Annex B and C.



Public Works and
Government Services
Canada

Travaux publics et
Services gouvernementaux
Canada

PURCHASING OFFICE - BUREAU DES ACHATS

CONTRACT – CONTRAT

Use “Canada accepts your bid” when you issued an RFB document, with Sections 1 and 2 completed, and the bidder has submitted a bid document.

Canada accepts your bid to provide to Canada the goods, services or both described in the Contract in accordance with the conditions and at the prices set out in the Contract.

Le Canada accepte votre soumission de fournir au Canada les biens, services ou les deux décrits dans le contrat conformément aux conditions et aux prix prévus au contrat.

Use “You are Requested” when you conducted a verbal solicitation, did not sent a RFB document to the bidder with Section 2 completed, and you did not review terms and conditions of Section 2 with the bidder

You are requested to sell to the Majesty the Queen in right of Canada, in accordance with the terms and conditions set out herein, referred to herein or attached hereto, the supplies and services listed herein and on any attached sheets at the price or prices set out therefor.

Nous vous demandons de vendre à Sa Majesté la Reine du chef du Canada, aux conditions énoncées ou incluses par référence dans les présentes et aux annexes ci-jointes, les articles et les services énumérés dans les présentes et sur toute feuille ci-annexée, au(x) prix indiqué(s).

Supplier to sign for a “You are Requested” contract only.

The vendor hereby accepts this contract Le fournisseur accepte le présent contrat	
Name, title of person authorized to sign (type or print) Nom et titre du signataire autorisé (caractère d'impression)	
Signature	Date

File No. – N° de dossier	
Date of Contract – Date du Contrat	
Contract No. - N° du contrat	Amendment No. - N° de modification
Client Reference No. (optional) - N° du référence du client (facultatif)	
Financial Code(s) – Code(s) financier(s)	
Duty - Droits <input checked="" type="checkbox"/> Included Inclus <input type="checkbox"/> Excluded En sus	GST - TPS/ HST – TVH <input checked="" type="checkbox"/> Included Inclus <input type="checkbox"/> Excluded En sus
FOB – FAB DESTINATION	
Destination See Section 2, Annex A. Voir Section 2, Annexe A.	
Invoices - Original and two copies must be completed and sent to: Factures – L’original et deux copies doivent être remplis et envoyés à : See Section 2, Article 6. Voir Section 2, Article 6.	
Address inquiries to : - Adresser toute demande de renseignements à : See Section 2, Article 4.1. Voir Section 2, Article 4.1.	
Area Code and Telephone No. Code régional et N° de téléphone	Facsimile No. N° de télécopieur
Total estimated cost – Coût total estimatif	
For the Minister – Pour le Ministre	

Return signed copy forthwith - Prière de retourner une copie dûment signée
immédiatement

PWGSC-TPSGC 9400-4 (11/2008) modified by Furniture Division July 20