

ITEM NO.	DWG No.	DESCRIPTION	Default/ QTY.
1	002	BASE PLATE	1
2	002	BOX SECTION ASSEMBLY	1
3	003	HINGE PLATE ASSEMBLY	1
4	002	LOWER DOOR ASSEMBLY	1
5	002	UPPER DOOR ASSEMBLY	1
6	002	BREAKER PANEL ASSEMBLY	1
7	004	ROOF CAP ASSEMBLY	1
8	004	ROOF SUPPORTS	4

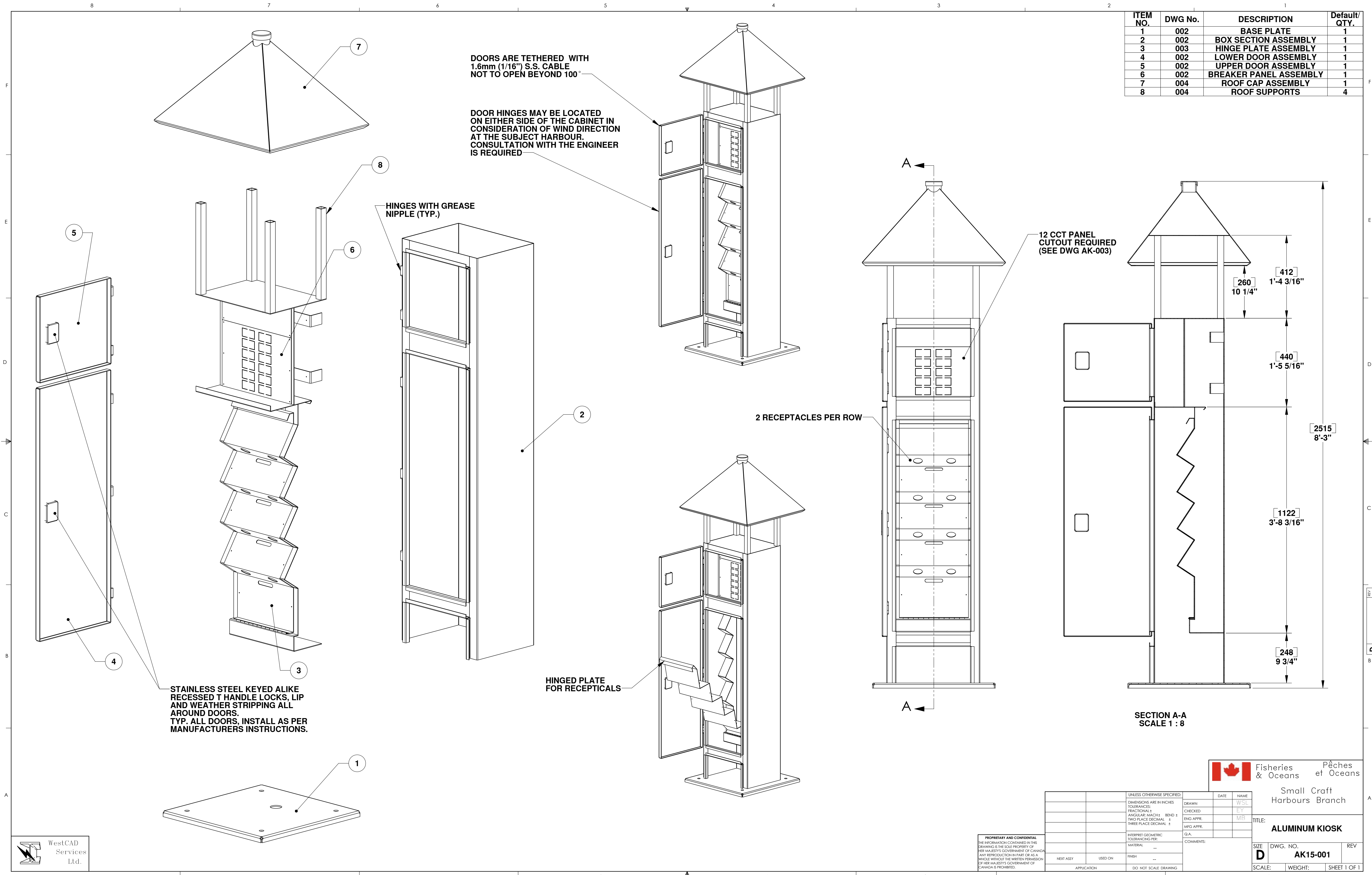

Fisheries & Oceans / Pêches et Océans

Small Craft Harbours Branch

ALUMINUM KIOSK

SIZE: **D** DWG. NO.: **AK15-001** REV: **1**
 SCALE: WEIGHT: SHEET 1 OF 1

UNLESS OTHERWISE SPECIFIED:		DATE	NAME
DIMENSIONS ARE IN INCHES	DRAWN		W.S.L.
TOLERANCES:	CHECKED		E.Y.
FRACTIONAL: ±	ENG APPR.		M.S.
ANGULAR: MATCH BEND ±	MFG APPR.		
TWO PLACE DECIMAL: ±			
THREE PLACE DECIMAL: ±			
INTERPRET GEOMETRIC TOLERANCING PER:	Q.A.		
MATERIAL:	COMMENTS:		
FINISH:			
NEXT ASSY:	DO NOT SCALE DRAWING		
APPLICATION:			

PROPRIETARY AND CONFIDENTIAL
 THE INFORMATION CONTAINED IN THIS DRAWING IS THE SOLE PROPERTY OF HER MAJESTY'S GOVERNMENT OF CANADA. ANY REPRODUCTION IN PART OR AS A WHOLE WITHOUT THE WRITTEN PERMISSION OF HER MAJESTY'S GOVERNMENT OF CANADA IS PROHIBITED.

WestCAD Services Ltd.

FOR REFERENCE ONLY

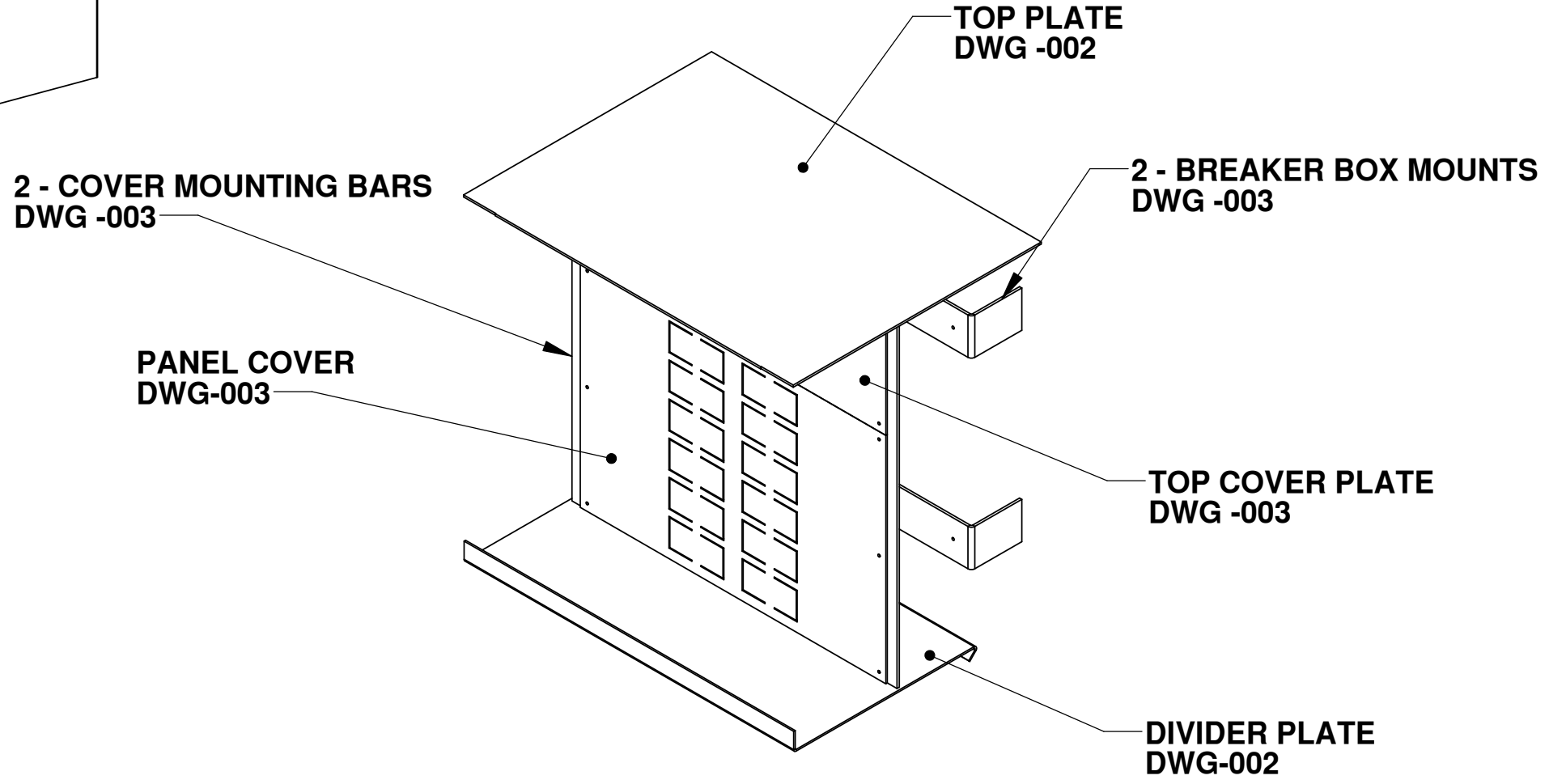
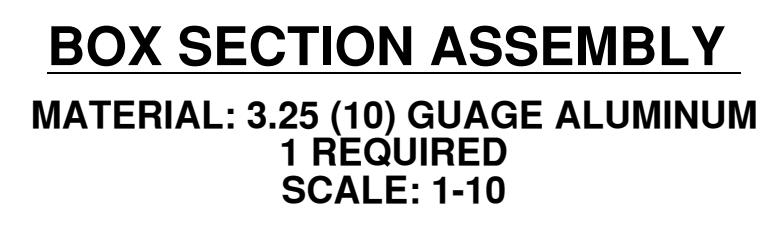
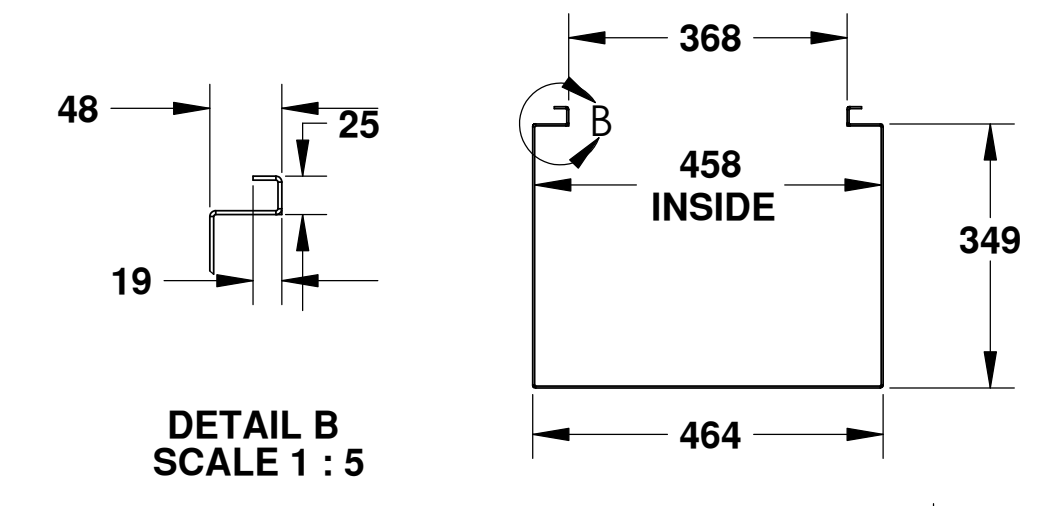
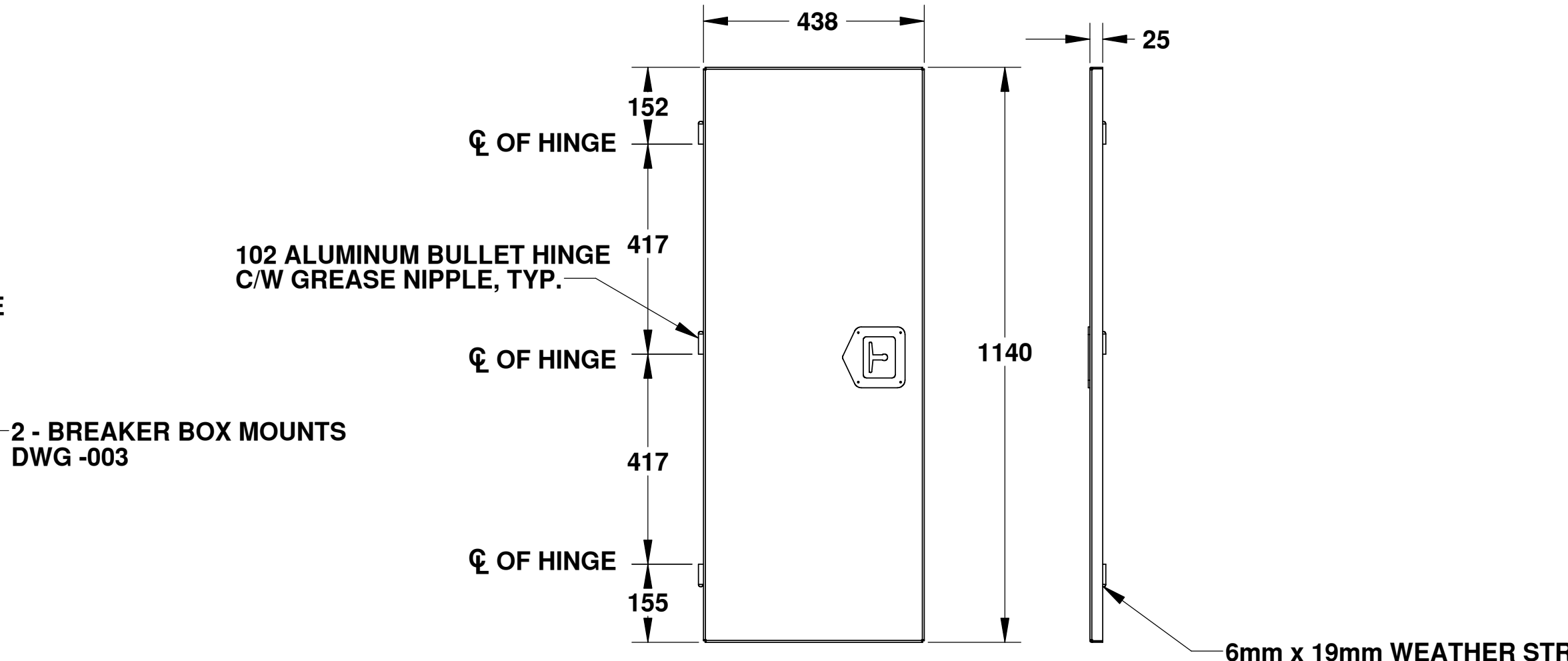
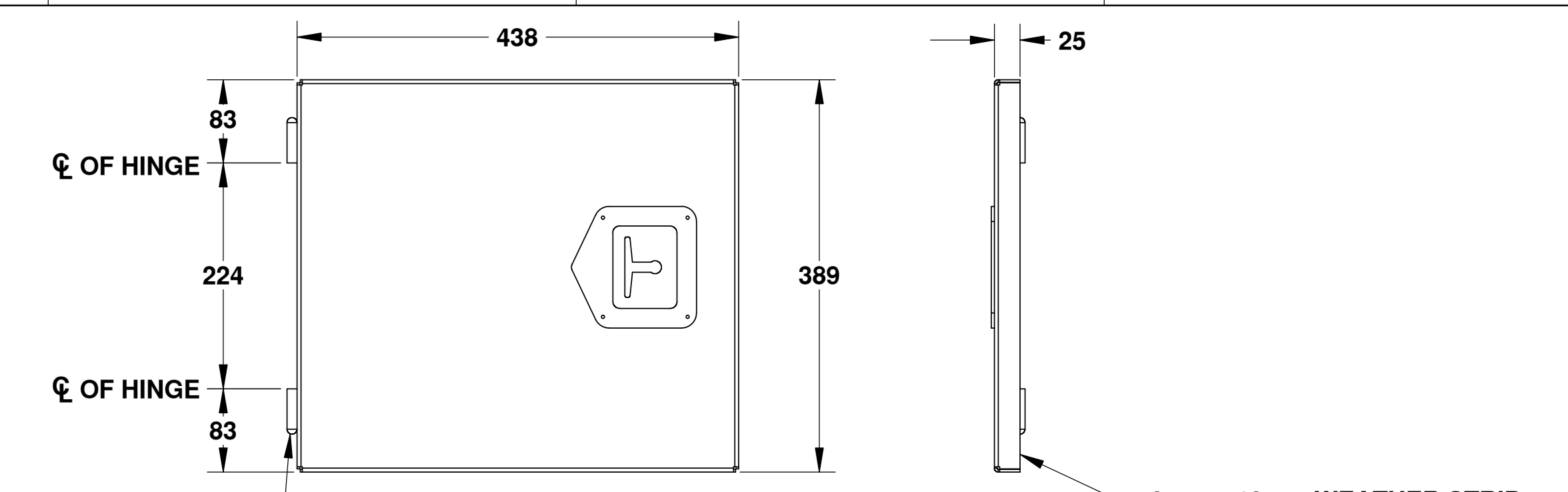
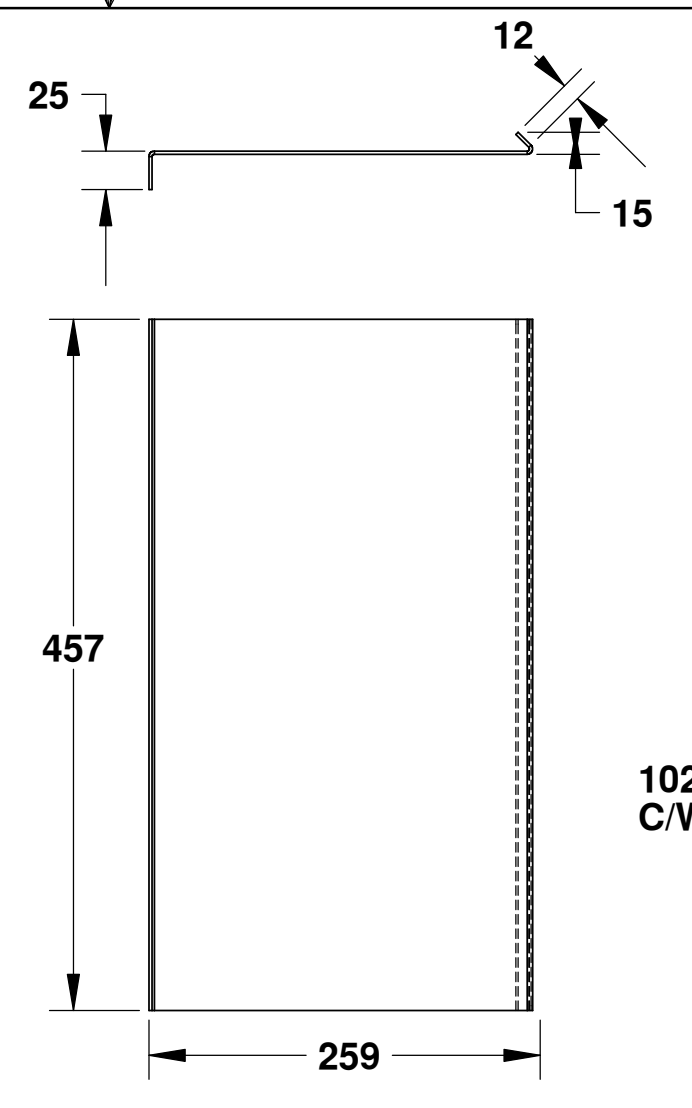
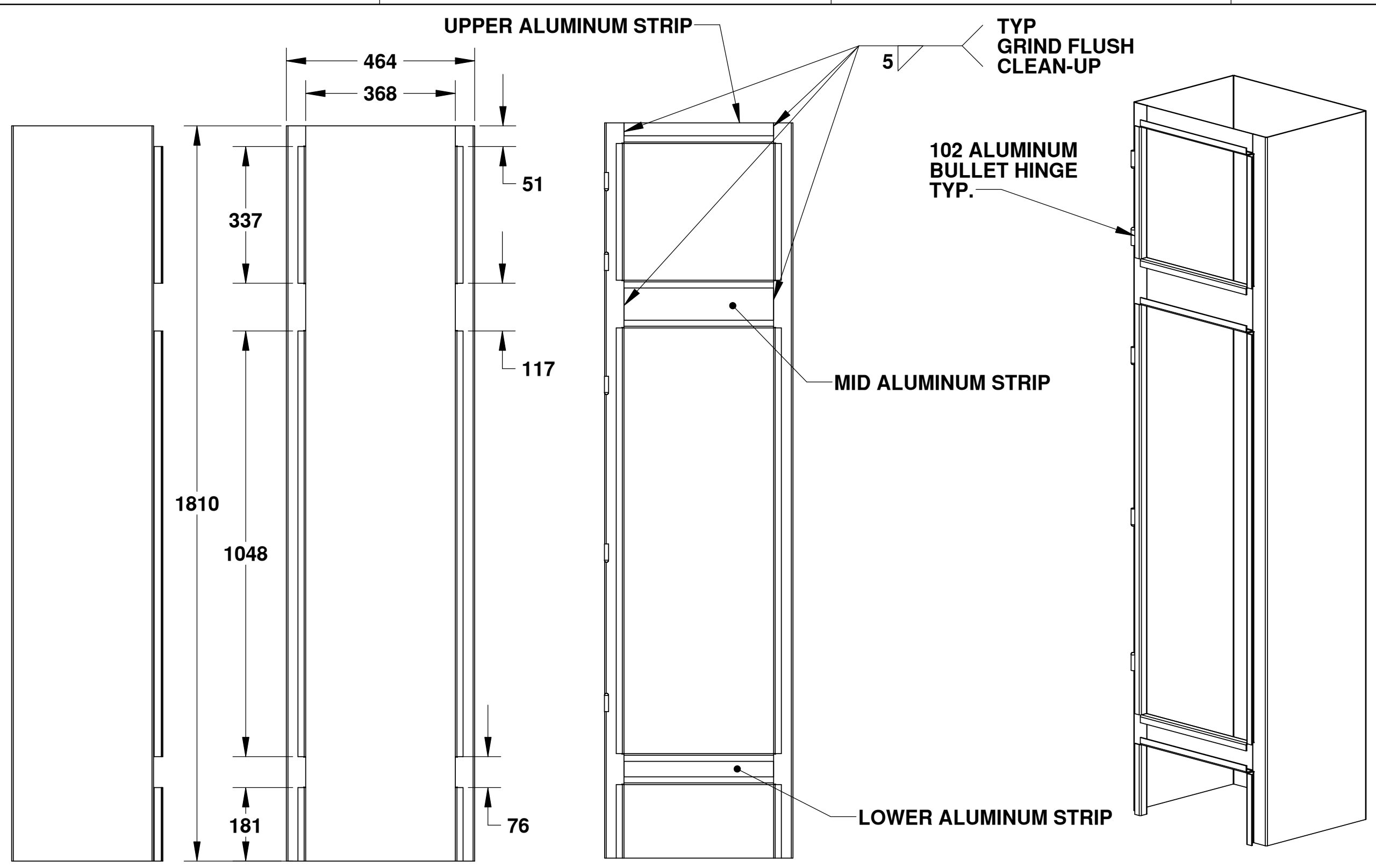

BREAKER PANEL ASSEMBLY

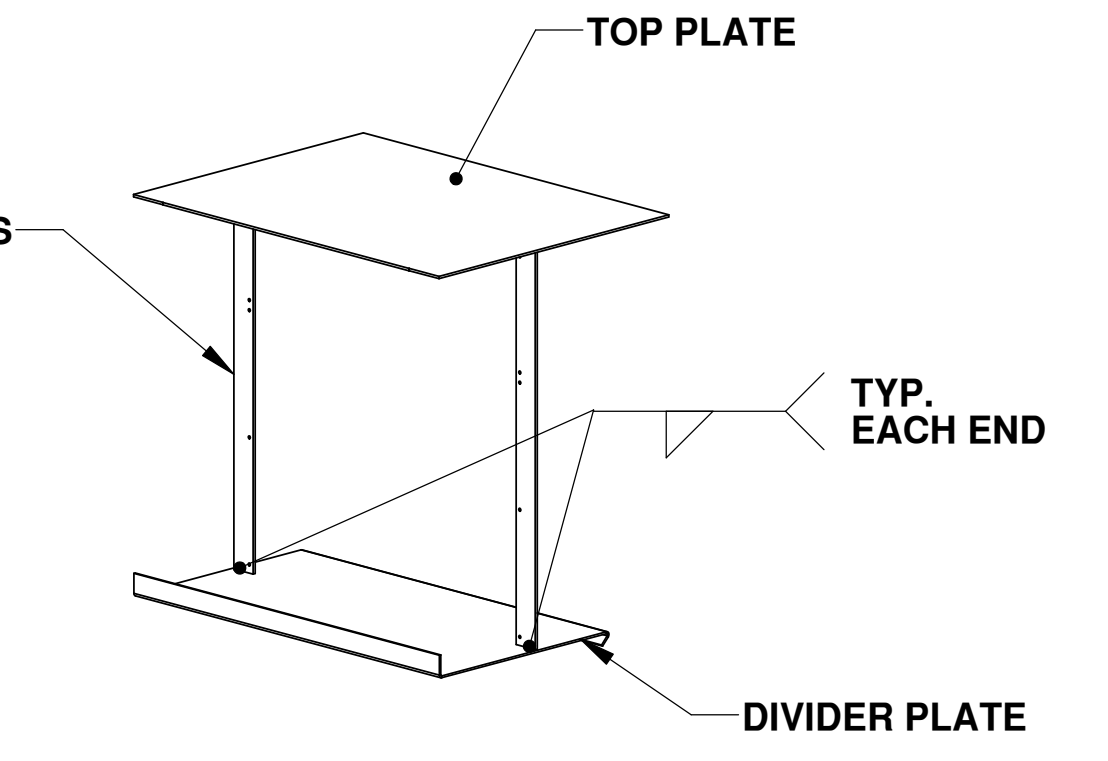
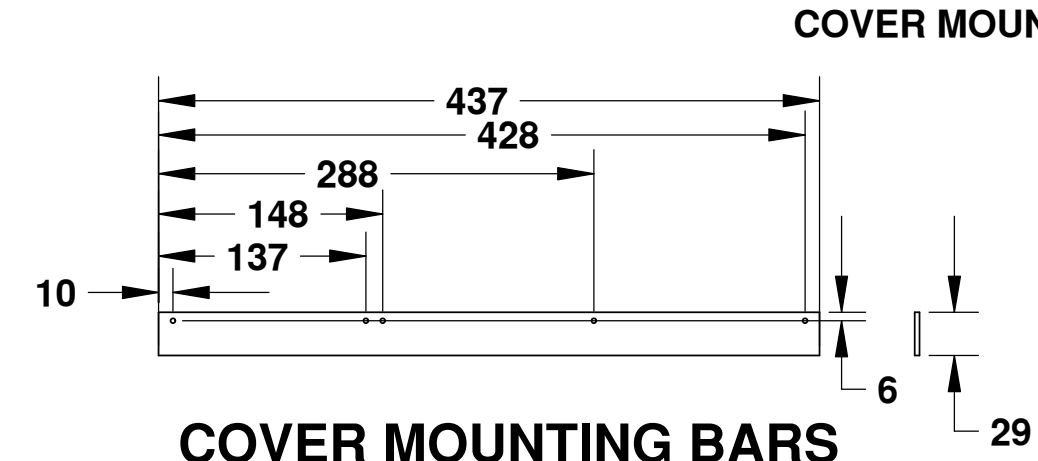
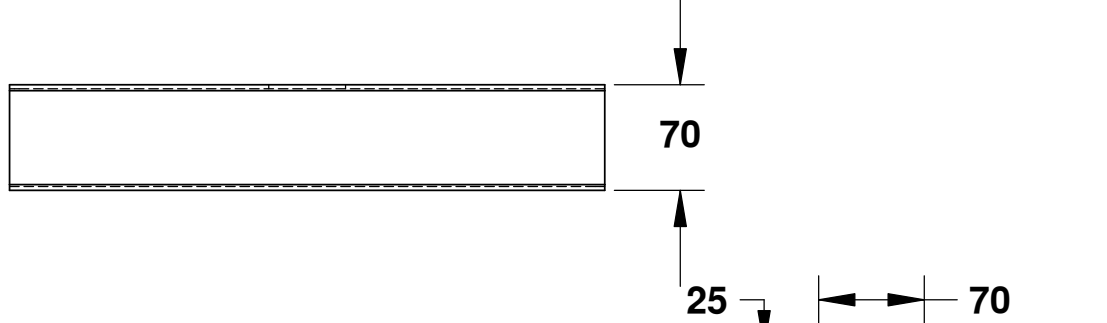
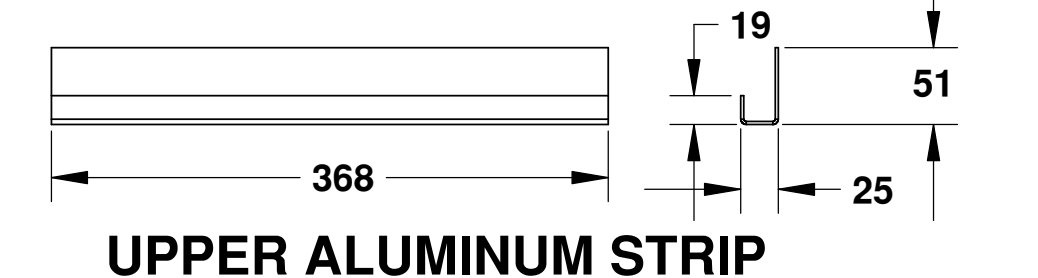

BREAKER PANEL ASSEMBLY LAYOUT

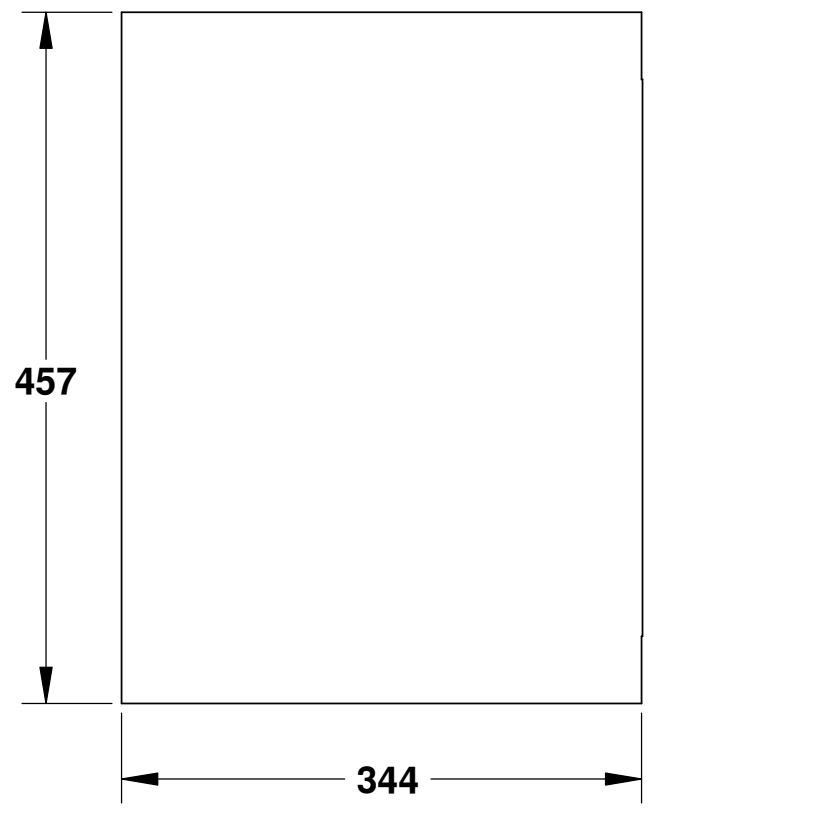
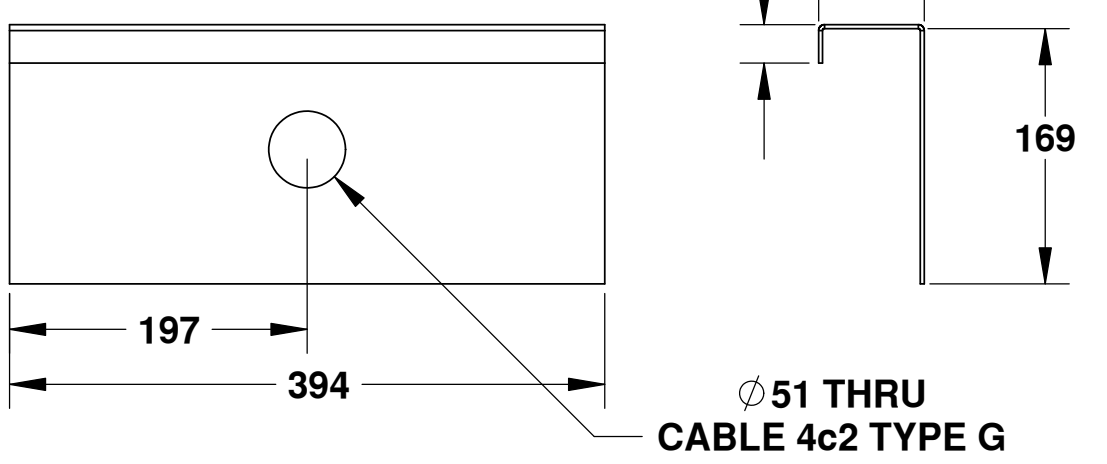
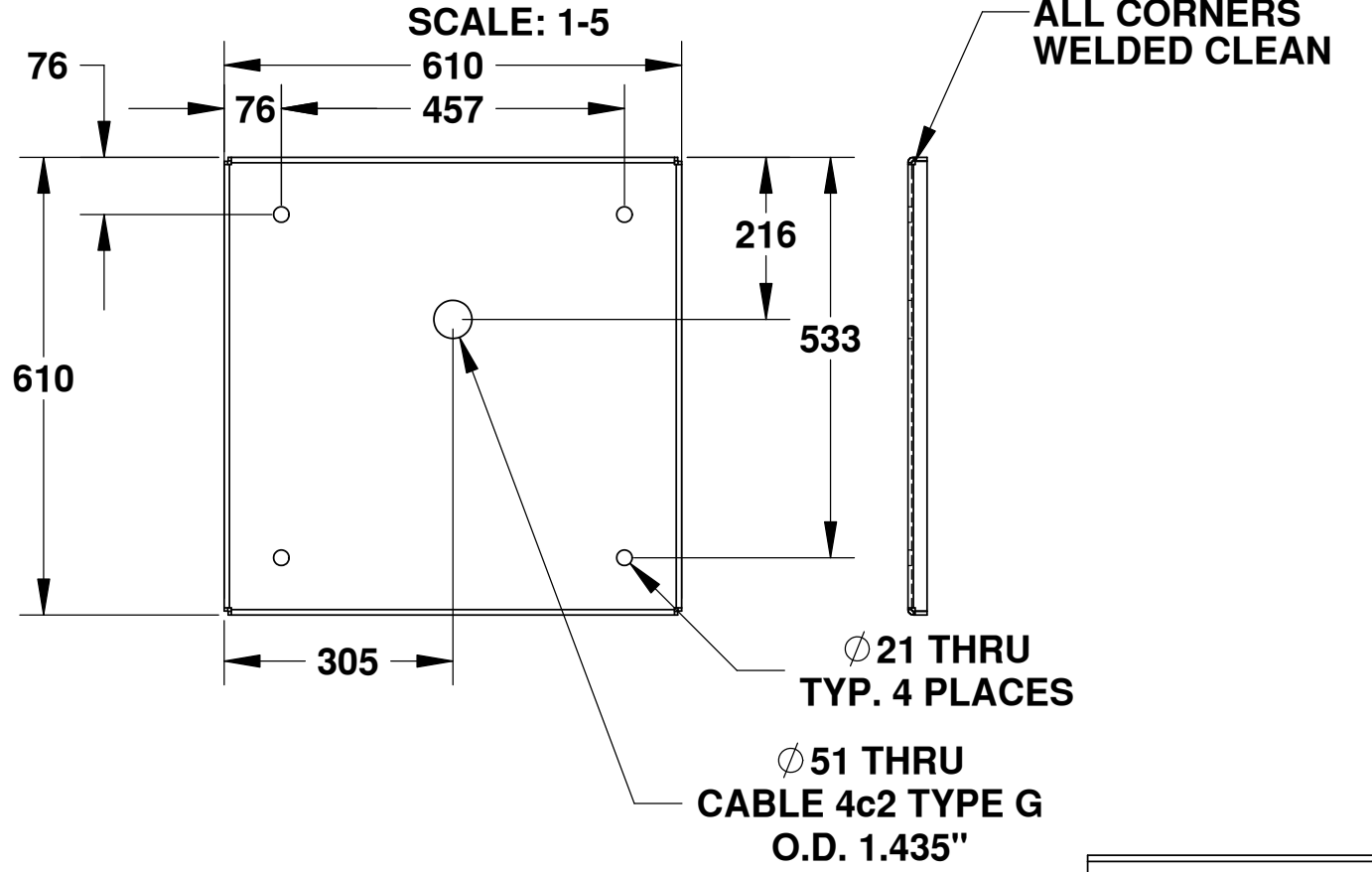

COVER MOUNTING BARS

BREAKER PANEL ASSEMBLY LAYOUT

NOTE:
FOR ALUMINUM SHEET FLATTEN LAYOUTS
SEE DWG. AK15-005

Fisheries & Oceans / Pêches et Océans
Small Craft Harbours Branch

UNLESS OTHERWISE SPECIFIED:	DATE	NAME
DIMENSIONS ARE IN INCHES		W.S.L.
TOLERANCES:		CHECKED
FRACTIONAL: 1/16		E.Y.
ANGULAR: MAX 1/2 BEND ±		ENG APPR.
TWO PLACE DECIMAL ±		M.B.
THREE PLACE DECIMAL ±		MFG APPR.
INTERPRET GEOMETRIC TOLERANCING PER:		O.A.
MATERIAL:		COMMENTS:
FINISH:		
NEXT ASSY:	USED ON:	
APPLICATION:	DO NOT SCALE DRAWING	

TITLE: ALUMINUM KIOSK	
SIZE: D	DWG. NO. AK15-002
SCALE: 1:10	WEIGHT: SHEET 1 OF 1

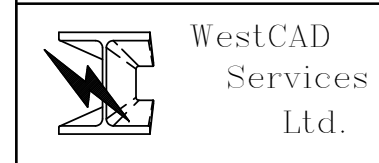

PROPRIETARY AND CONFIDENTIAL
THE INFORMATION CONTAINED IN THIS DRAWING IS THE SOLE PROPERTY OF HER MAJESTY'S GOVERNMENT OF CANADA. ANY REPRODUCTION IN PART OR AS A WHOLE WITHOUT THE WRITTEN PERMISSION OF HER MAJESTY'S GOVERNMENT OF CANADA IS PROHIBITED.

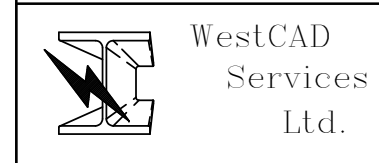
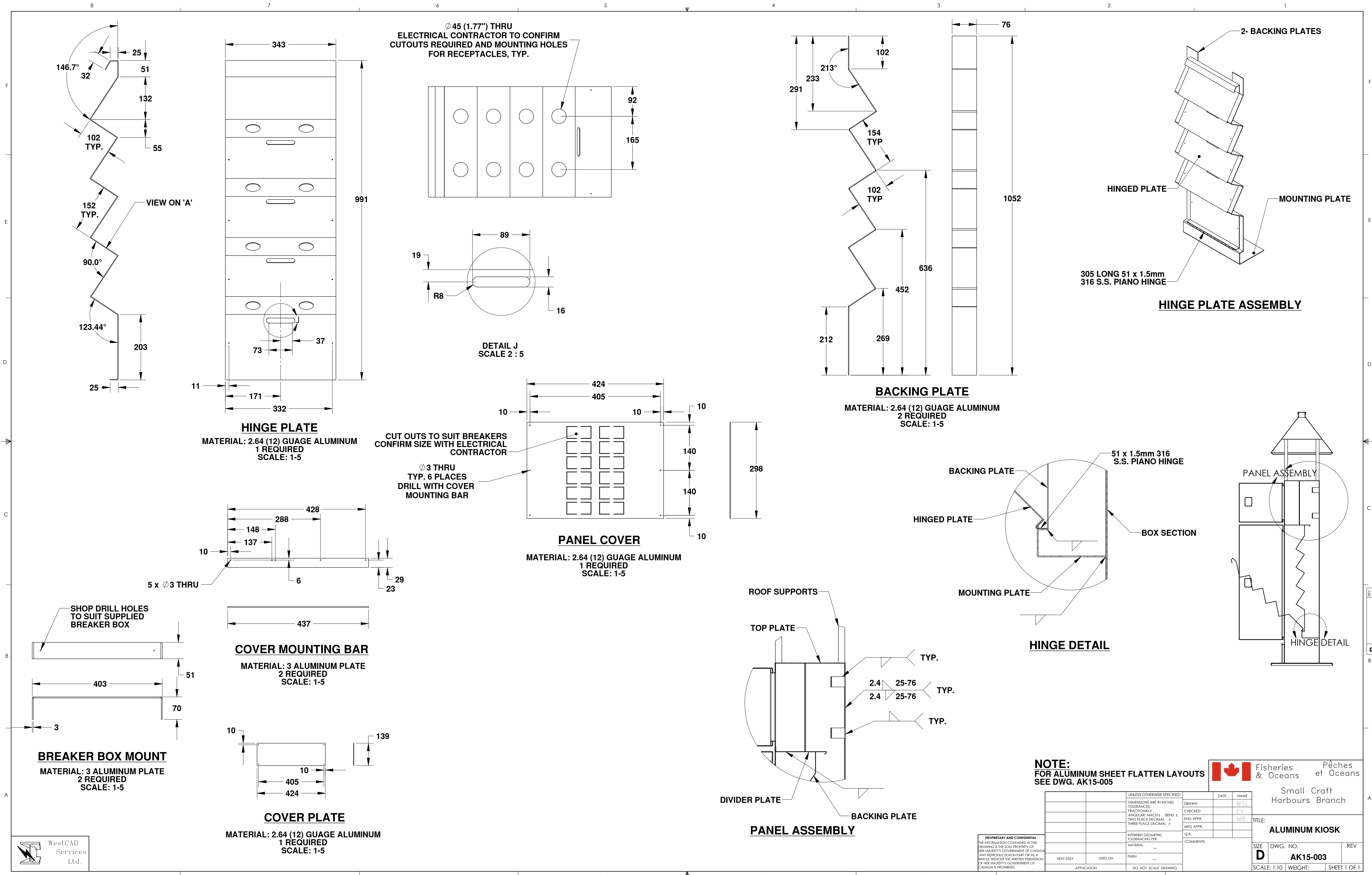

PROPRIETARY AND CONFIDENTIAL
THE INFORMATION CONTAINED IN THIS
DRAWING IS THE SOLE PROPERTY OF
HER MAJESTY'S GOVERNMENT OF CANADA.
ANY REPRODUCTION IN PART OR AS A
WHOLE WITHOUT THE WRITTEN PERMISSION
OF HER MAJESTY'S GOVERNMENT OF
CANADA IS PROHIBITED.

UNLESS OTHERWISE SPECIFIED:	DATE	NAME
DIMENSIONS ARE IN INCHES		W/S
TOLERANCES:		CHECKED
FRACTIONAL: ±		EY
ANGULAR: MATCH BEND ±		ENG APPR.
TWO PLACE DECIMAL: ±		M/B
THREE PLACE DECIMAL: ±		MFG APPR.
INTERPRET GEOMETRIC TOLERANCING PER:		O.A.
MATERIAL: --		COMMENTS:
FINISH: --		
NEXT ASSY:	USED ON:	
APPLICATION:	DO NOT SCALE DRAWING	

Small Craft Harbours Branch

ALUMINUM KIOSK

SIZE: **D** DWG. NO.: **AK15-003** REV: **1**

SCALE: 1:10 WEIGHT: SHEET 1 OF 1



Fisheries & Oceans Pêches et Océans

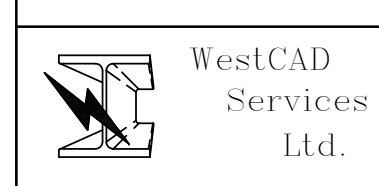
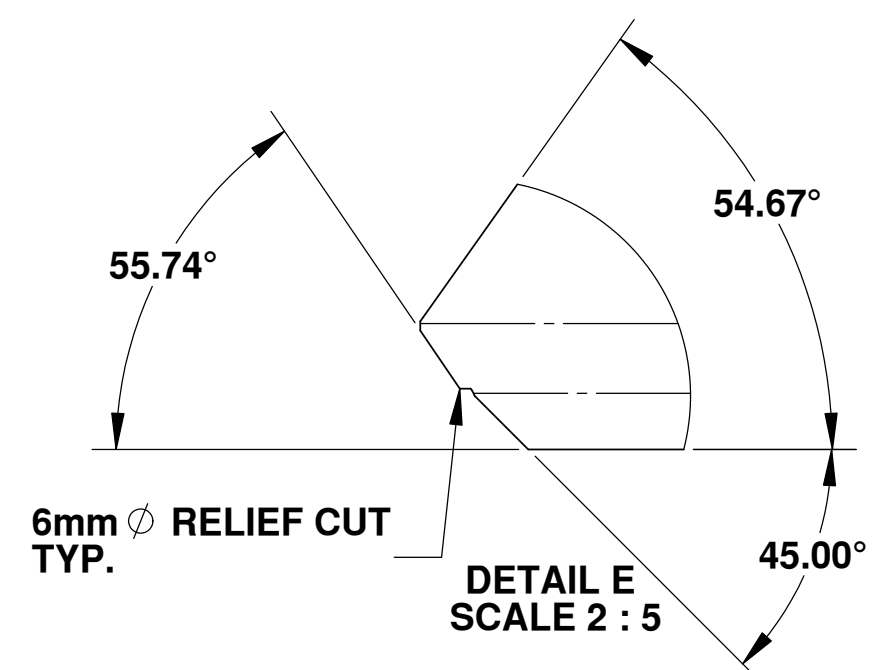
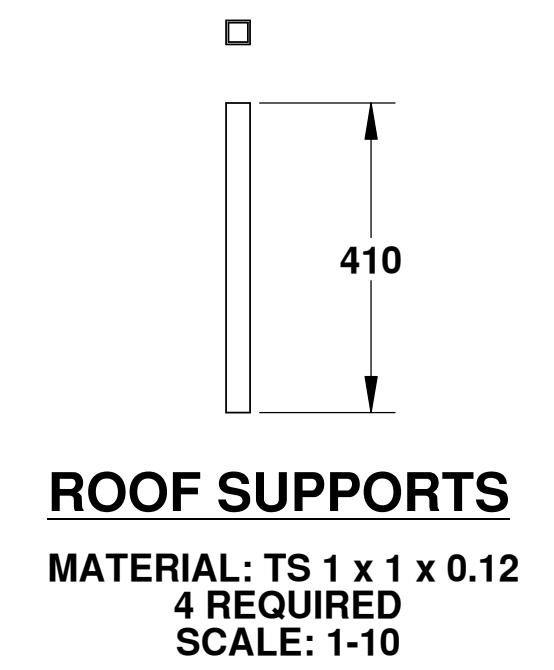
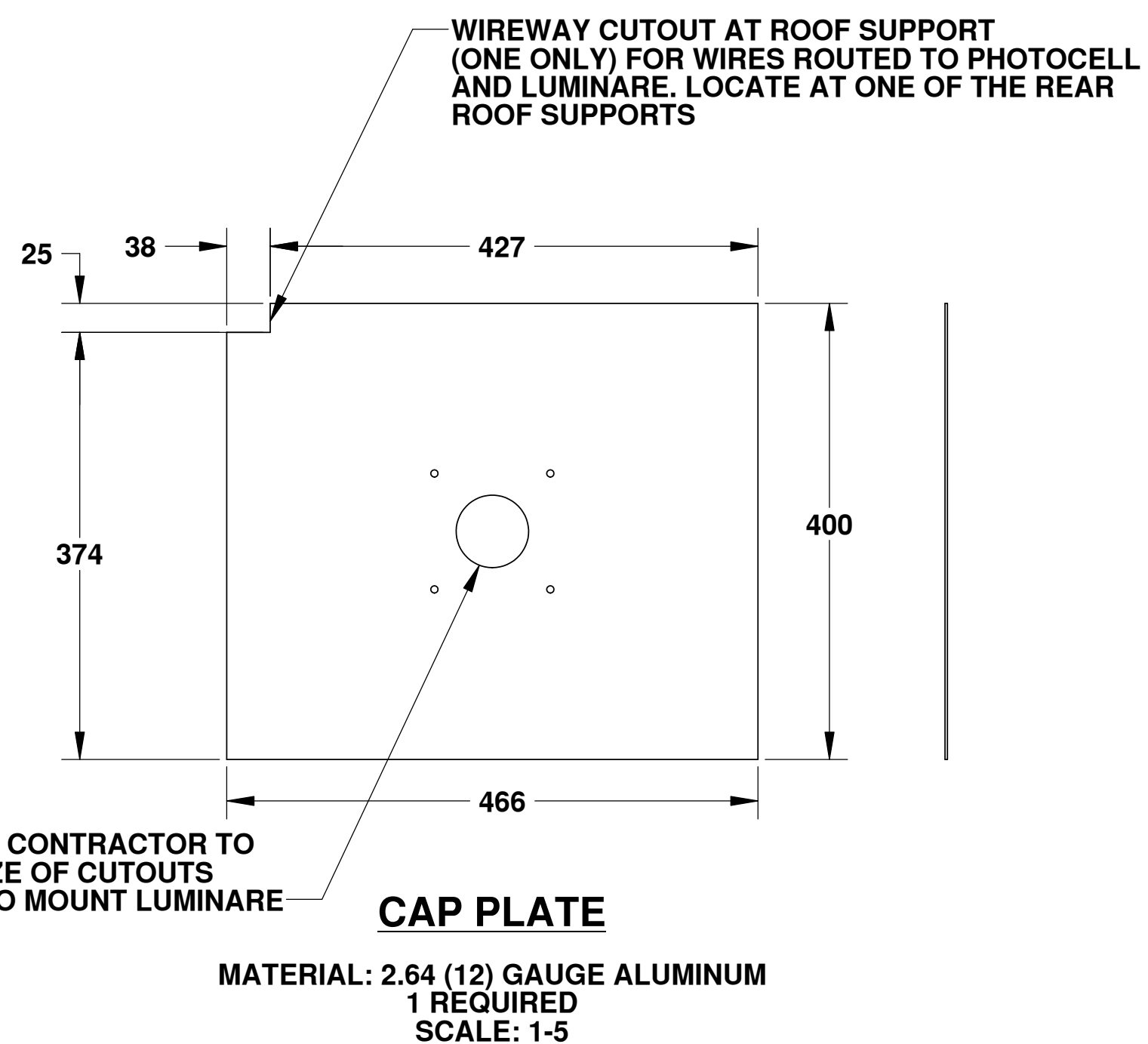
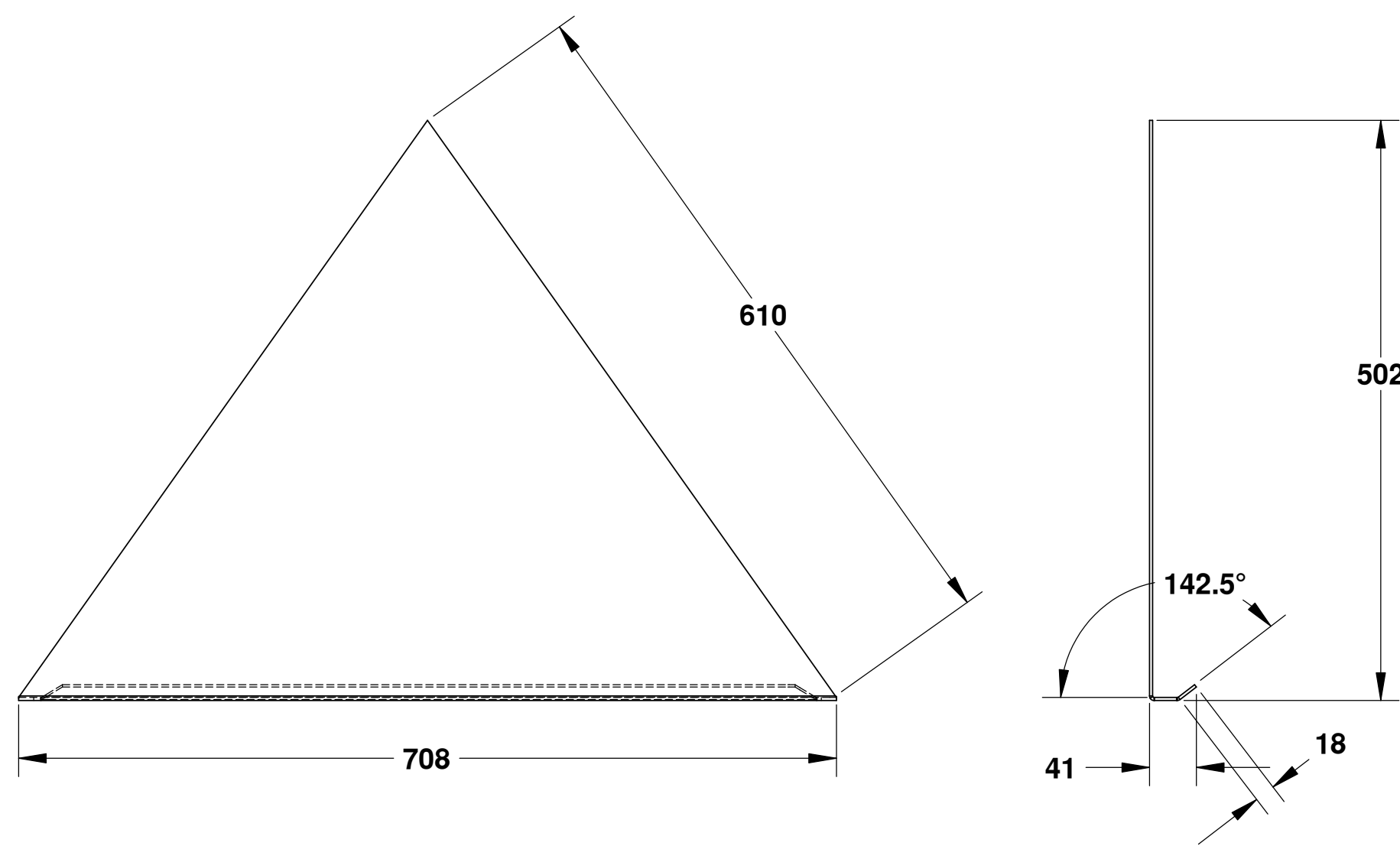
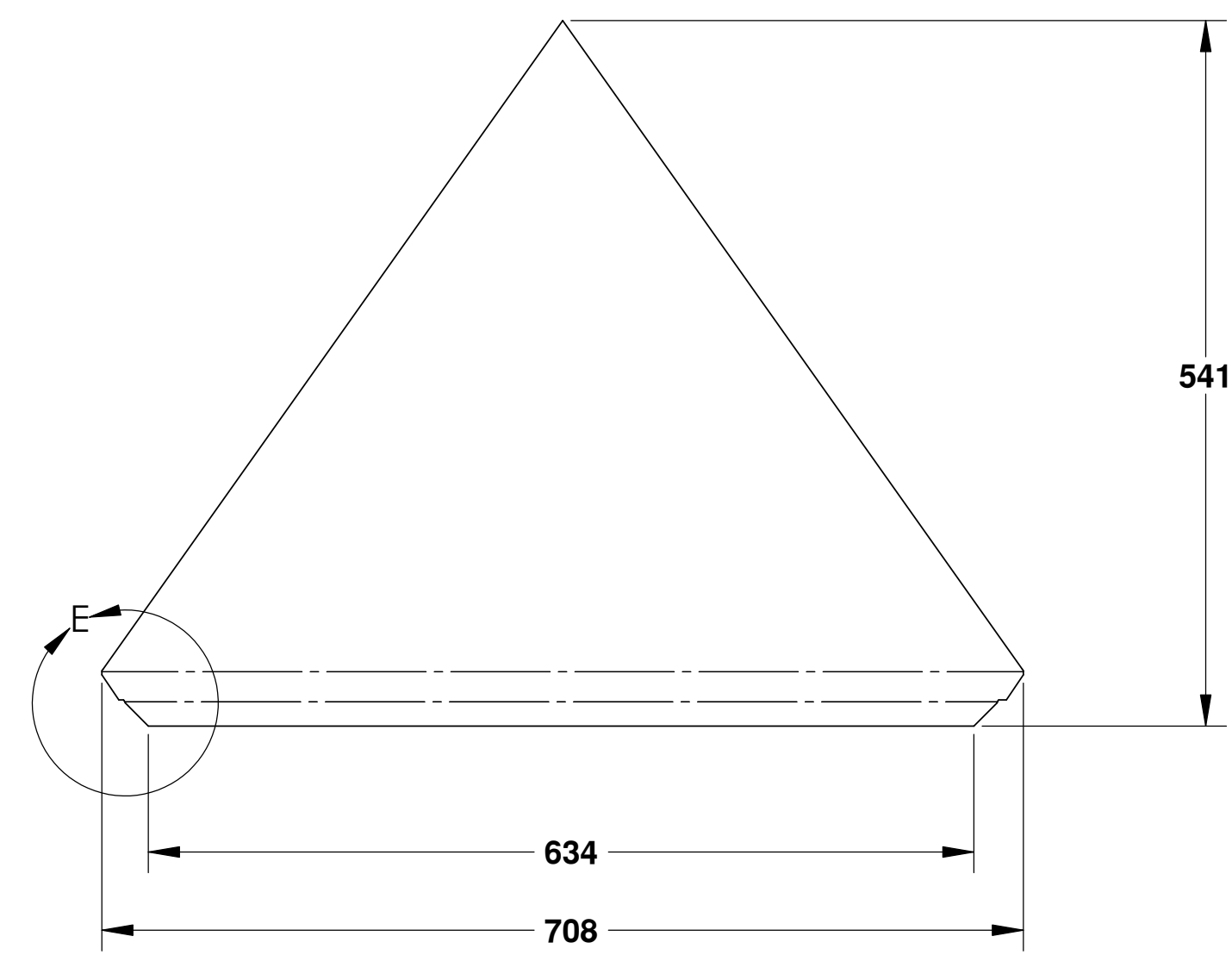
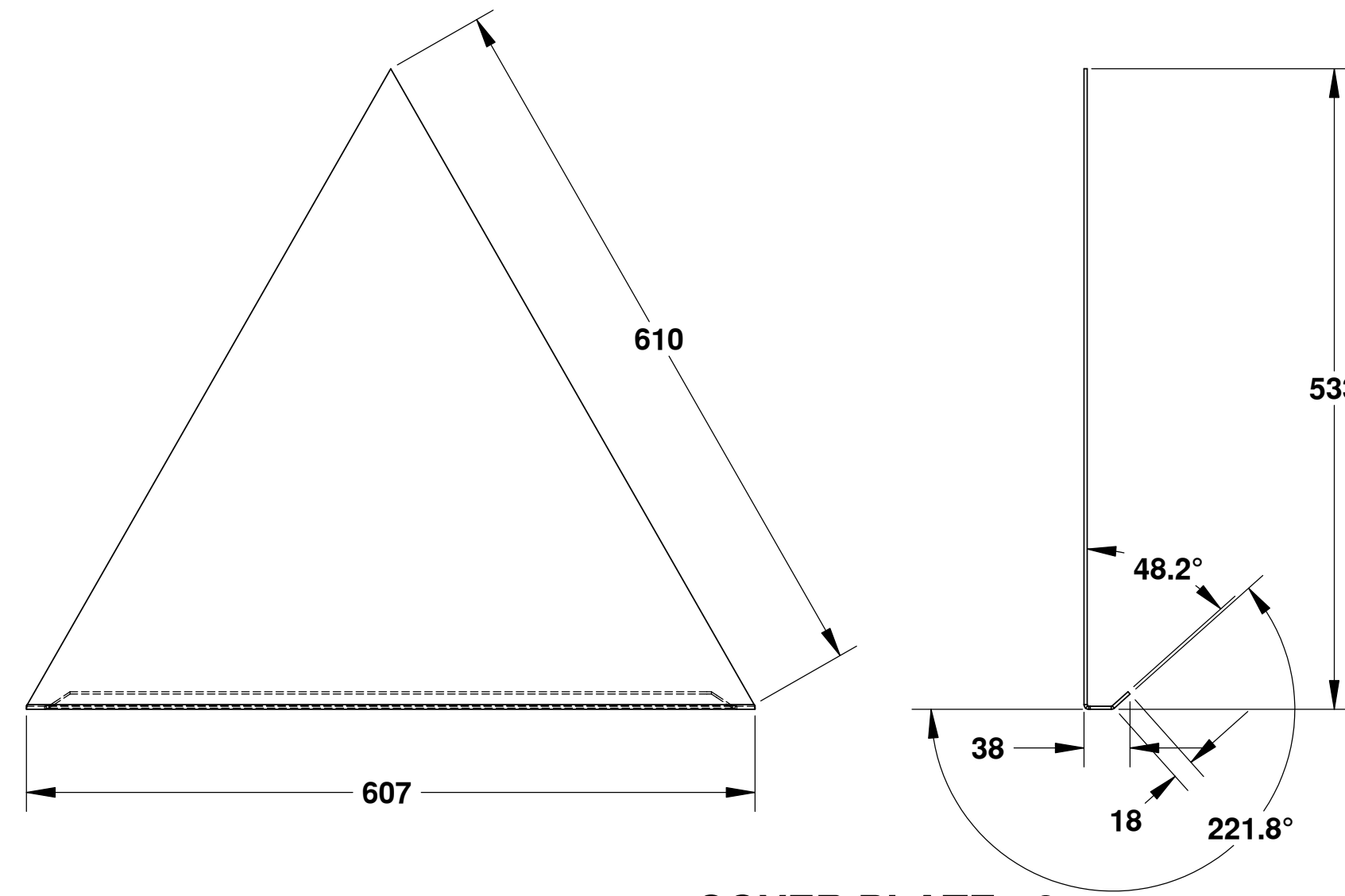
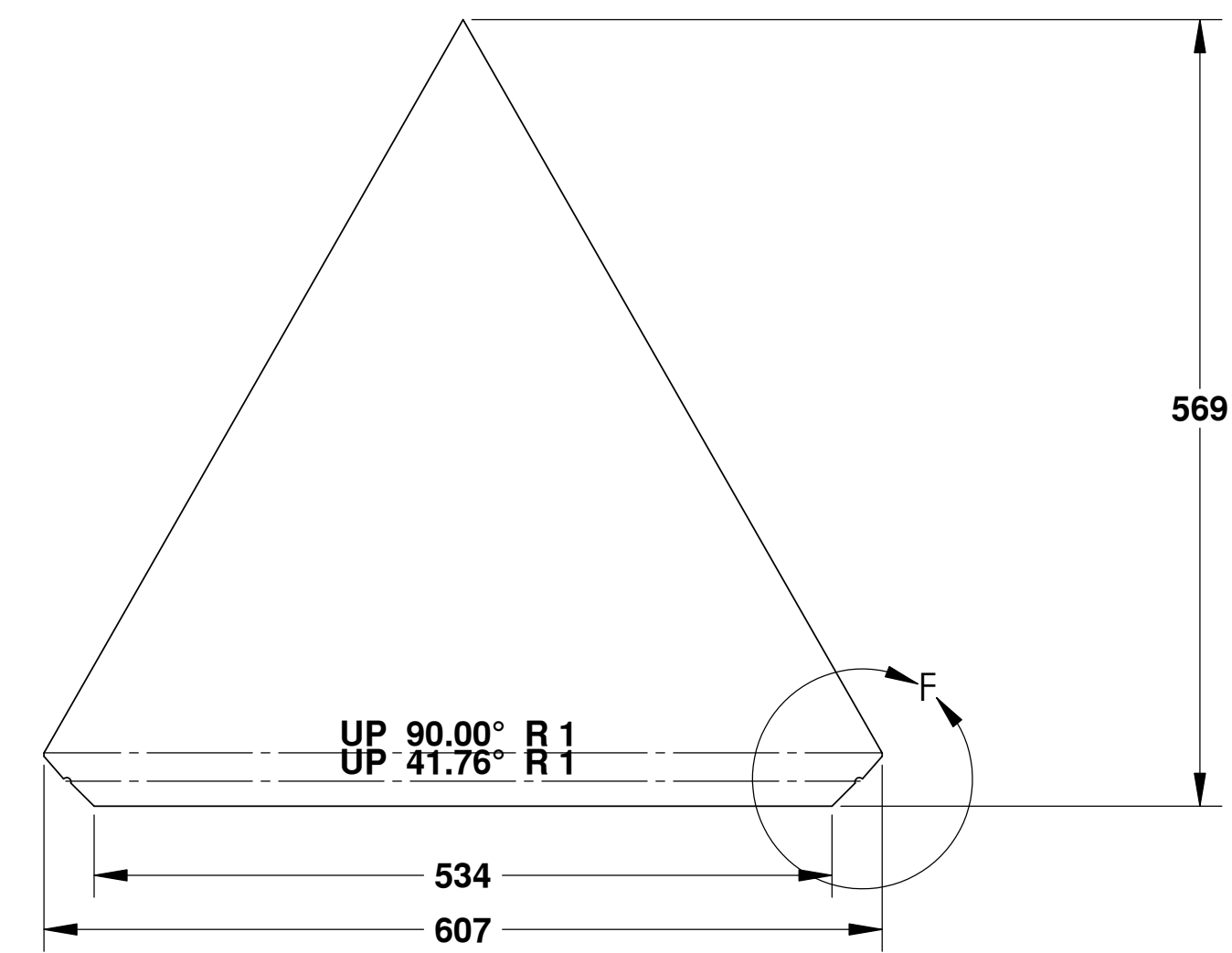
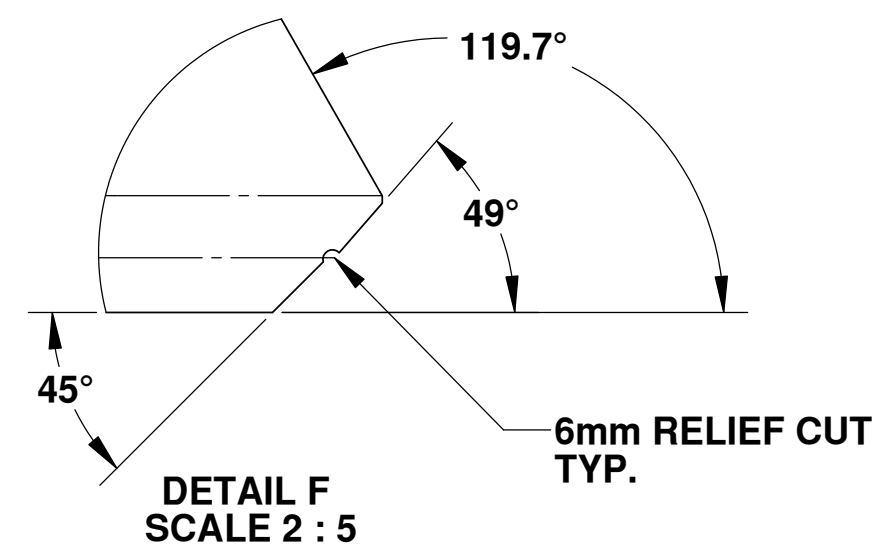
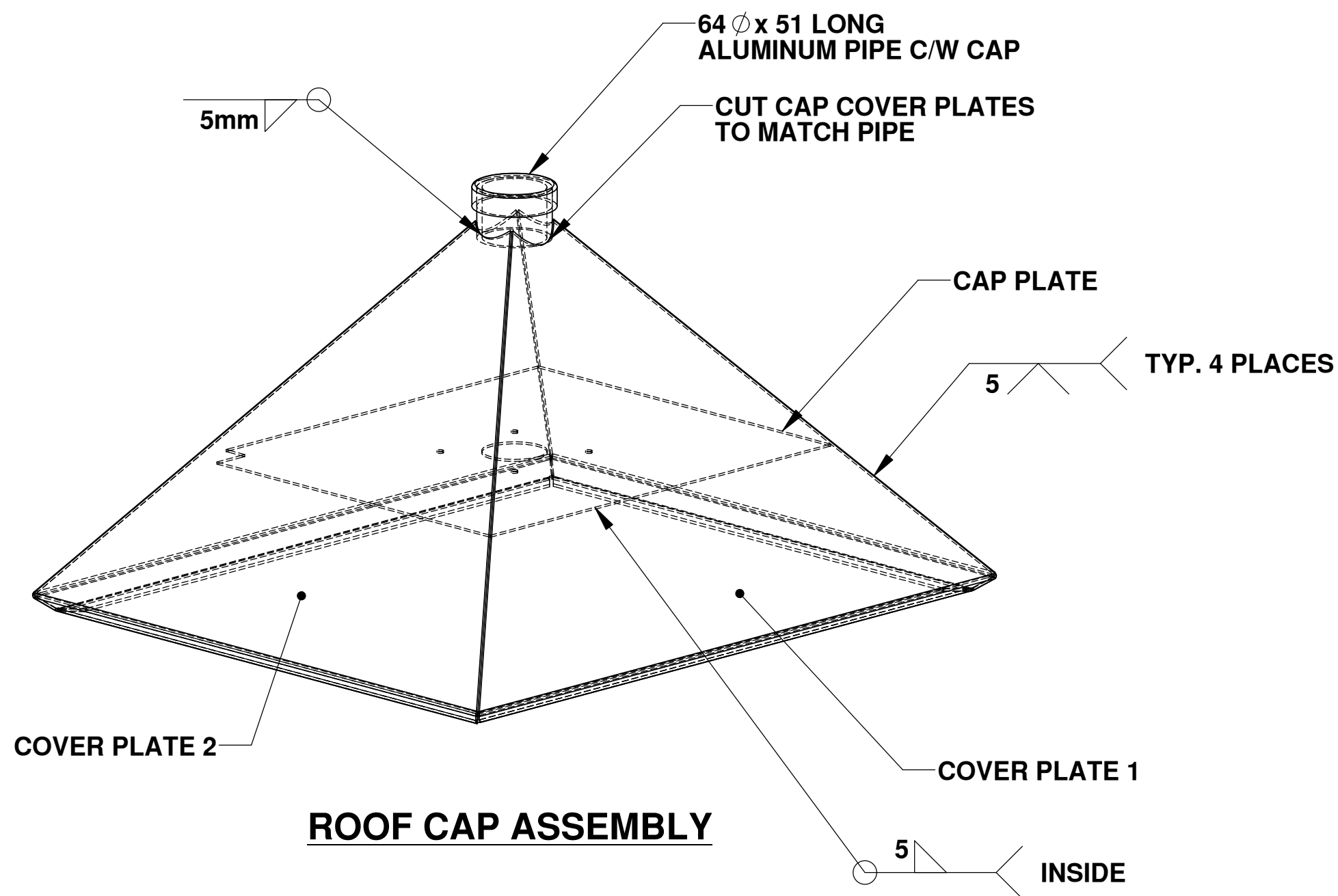

PROPRIETARY AND CONFIDENTIAL
THE INFORMATION CONTAINED IN THIS DRAWING IS THE SOLE PROPERTY OF HER MAJESTY'S GOVERNMENT OF CANADA. ANY REPRODUCTION IN PART OR AS A WHOLE WITHOUT THE WRITTEN PERMISSION OF HER MAJESTY'S GOVERNMENT OF CANADA IS PROHIBITED.

UNLESS OTHERWISE SPECIFIED:		DATE	NAME
DIMENSIONS ARE IN INCHES	DRAWN		WSL
TOLERANCES:	CHECKED		EY
FRACTIONAL: ±	ENG APPR.		MB
ANGULAR: MATCH BEND ±	MFG APPR.		
TWO PLACE DECIMAL: ±			
THREE PLACE DECIMAL: ±			
INTERPRET GEOMETRIC TOLERANCING PER:	O.A.		
MATERIAL:	---		
FINISH:	---		
NEXT ASSY:	USED ON:	APPLICATION	
		DO NOT SCALE DRAWING	

Fisheries & Oceans Pêches et Océans
Small Craft Harbours Branch
ALUMINUM KIOSK
DWG. NO. **AK15-004**
SCALE: 1:10 | WEIGHT: | SHEET 1 OF 1

FOR REFERENCE ONLY

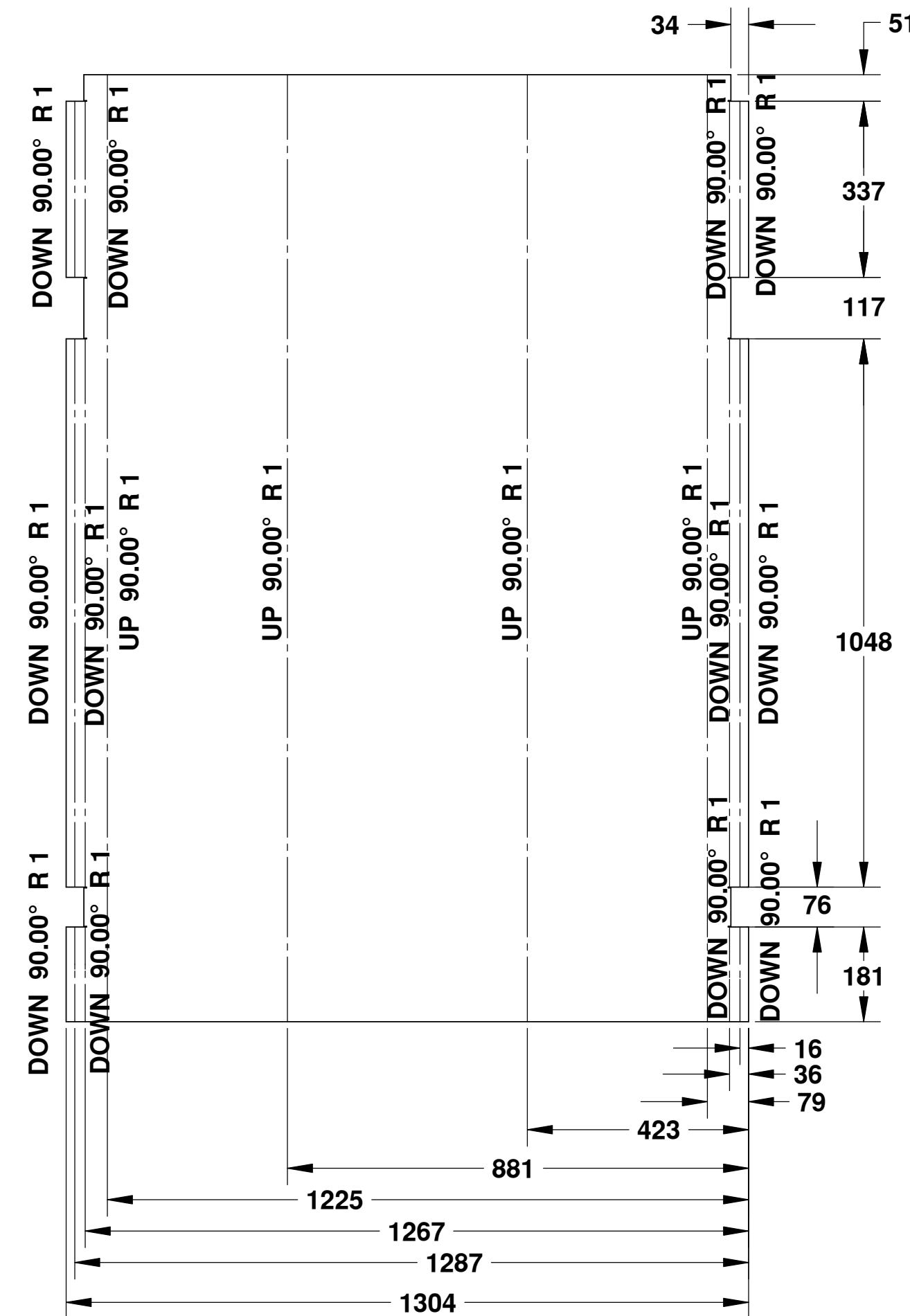

BOX SECTION
SCALE: 1-10

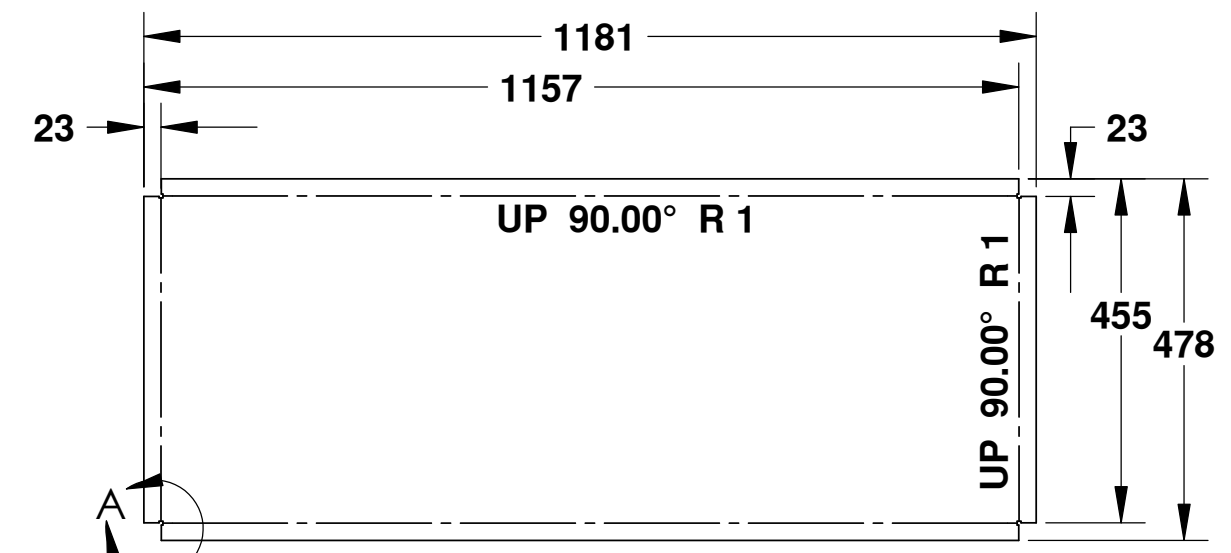

LOWER DOOR
SCALE: 1-10

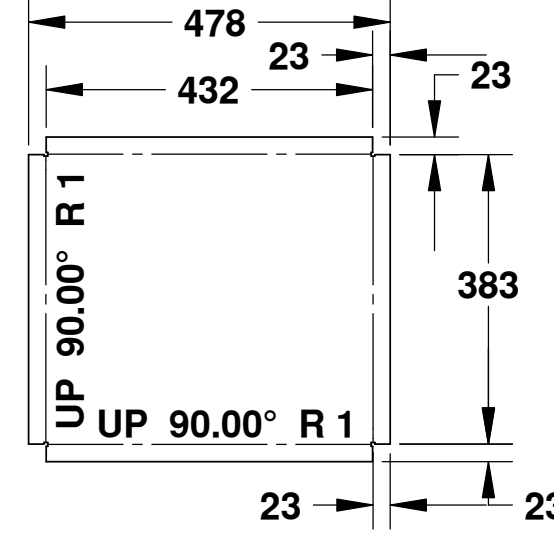

UPPER DOOR
SCALE: 1-10

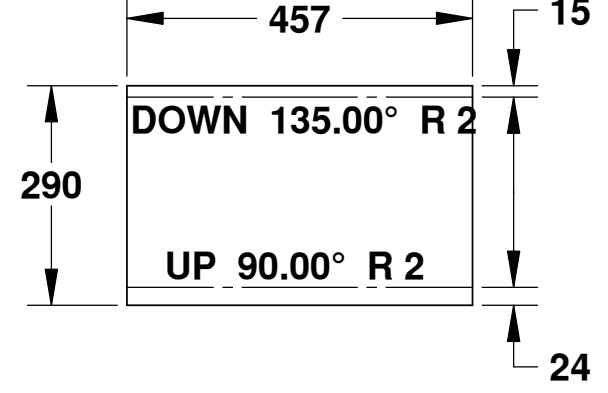

DIVIDER PLATE
SCALE: 1-10

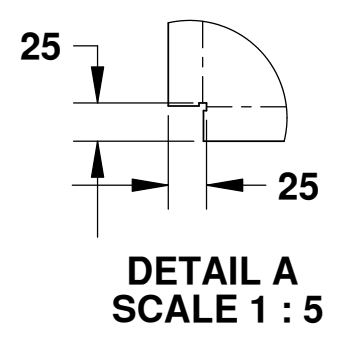

DETAIL A
SCALE 1 : 5

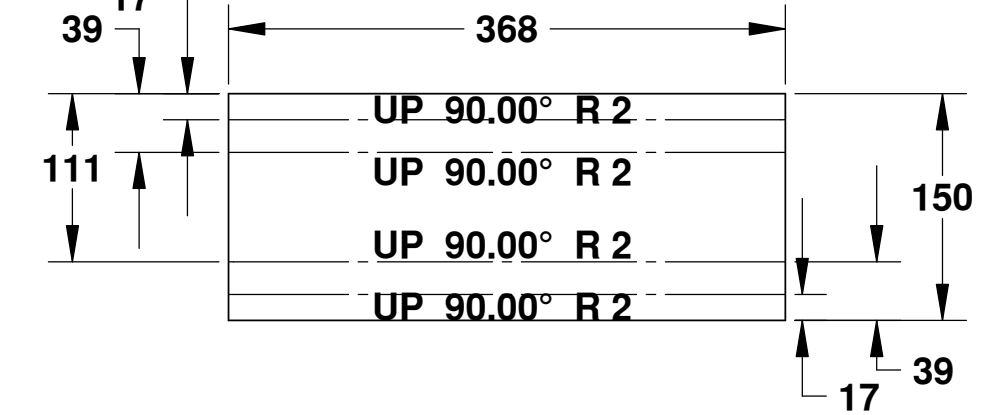

LOWER ALUMINUM STRIP
SCALE: 1-5

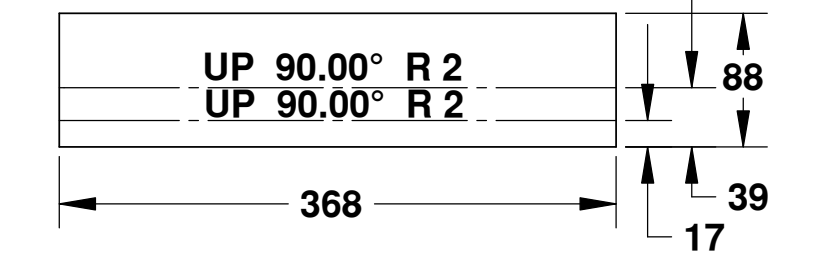

UPPER ALUMINUM STRIP
SCALE: 1-5

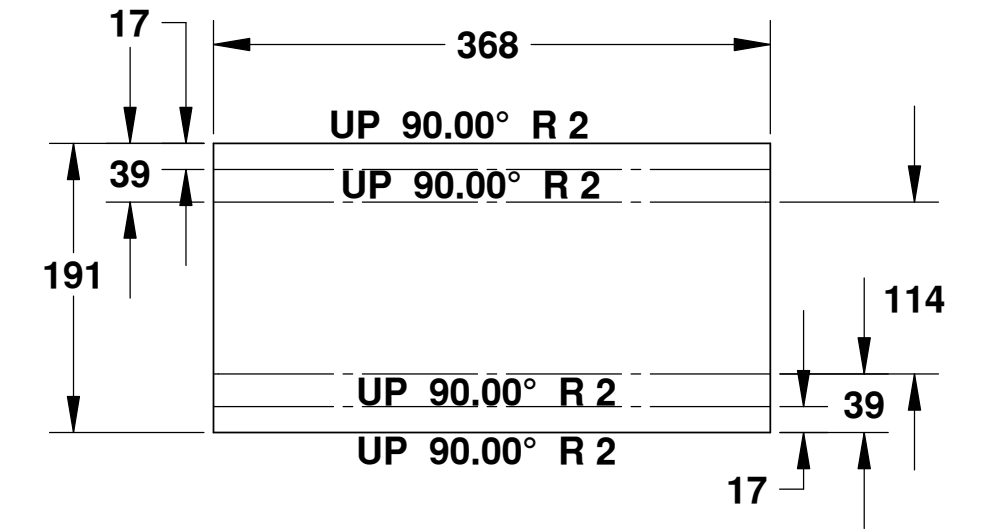

MID ALUMINUM STRIP
SCALE: 1-5

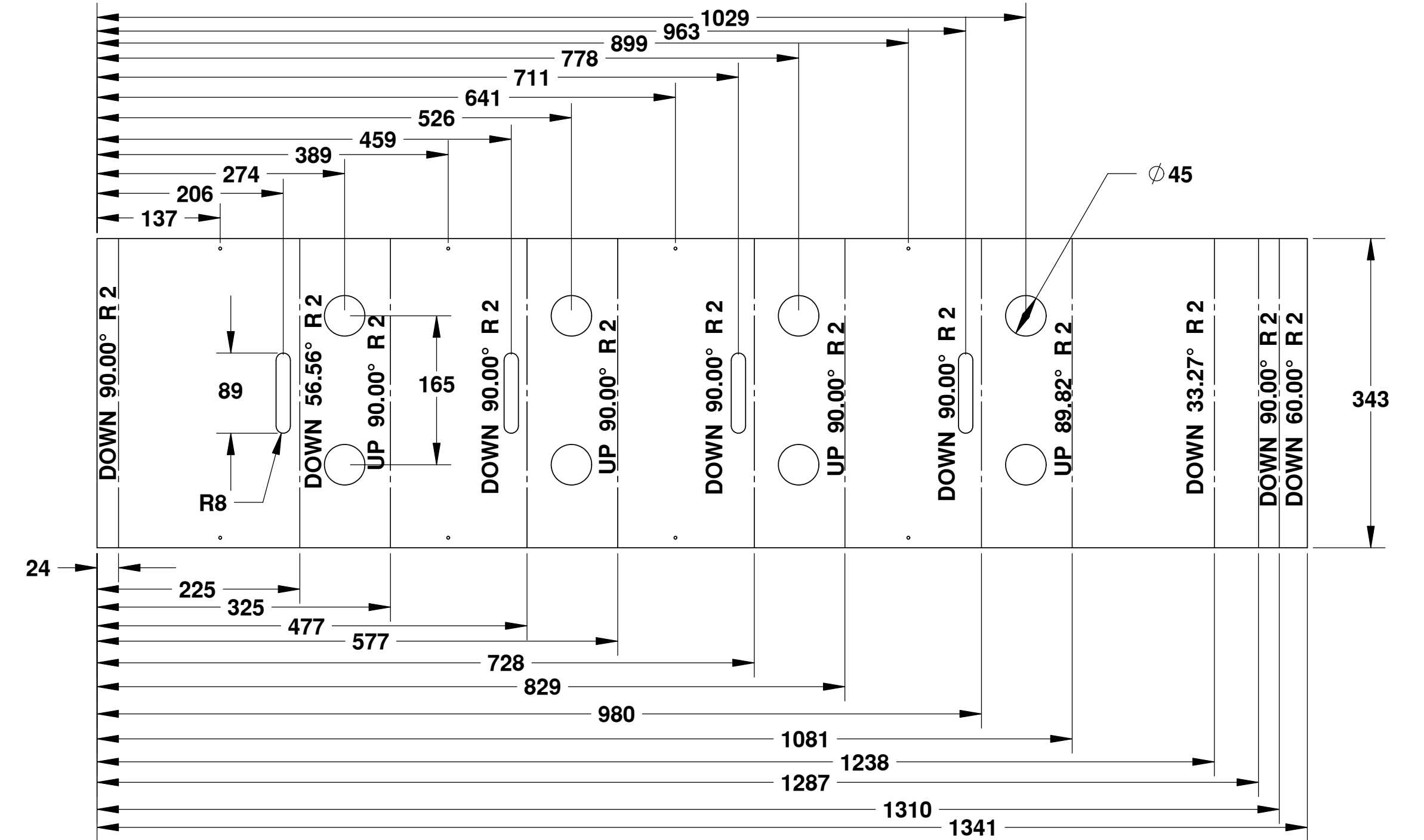

HINGE PLATE
SCALE: 1-5

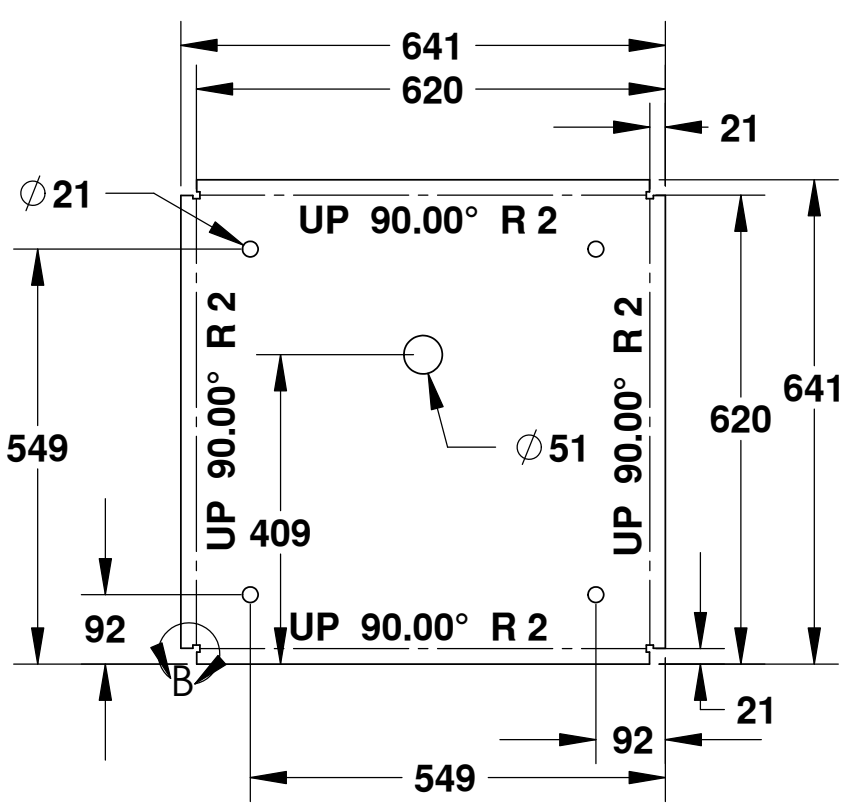

BASE PLATE
SCALE: 1-10

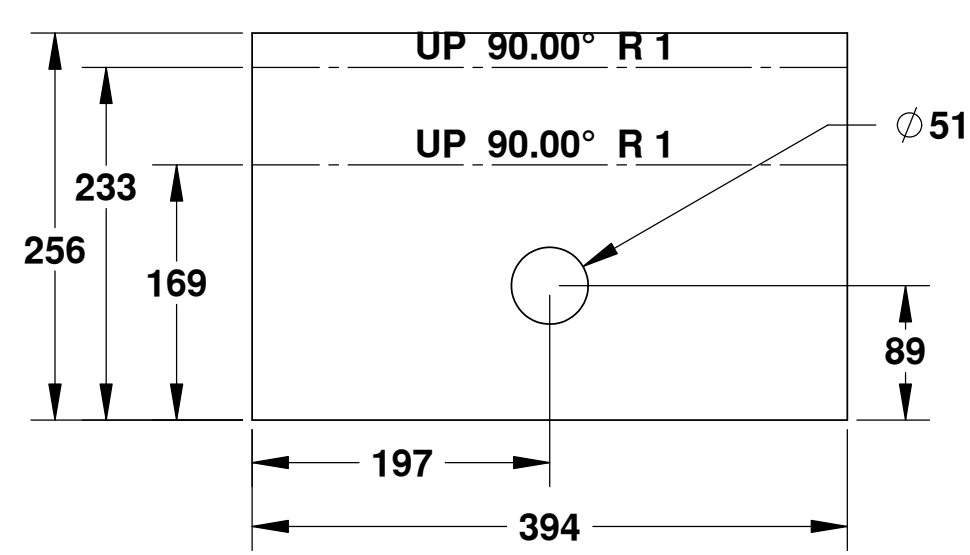

MOUNTING PLATE
SCALE: 1-5

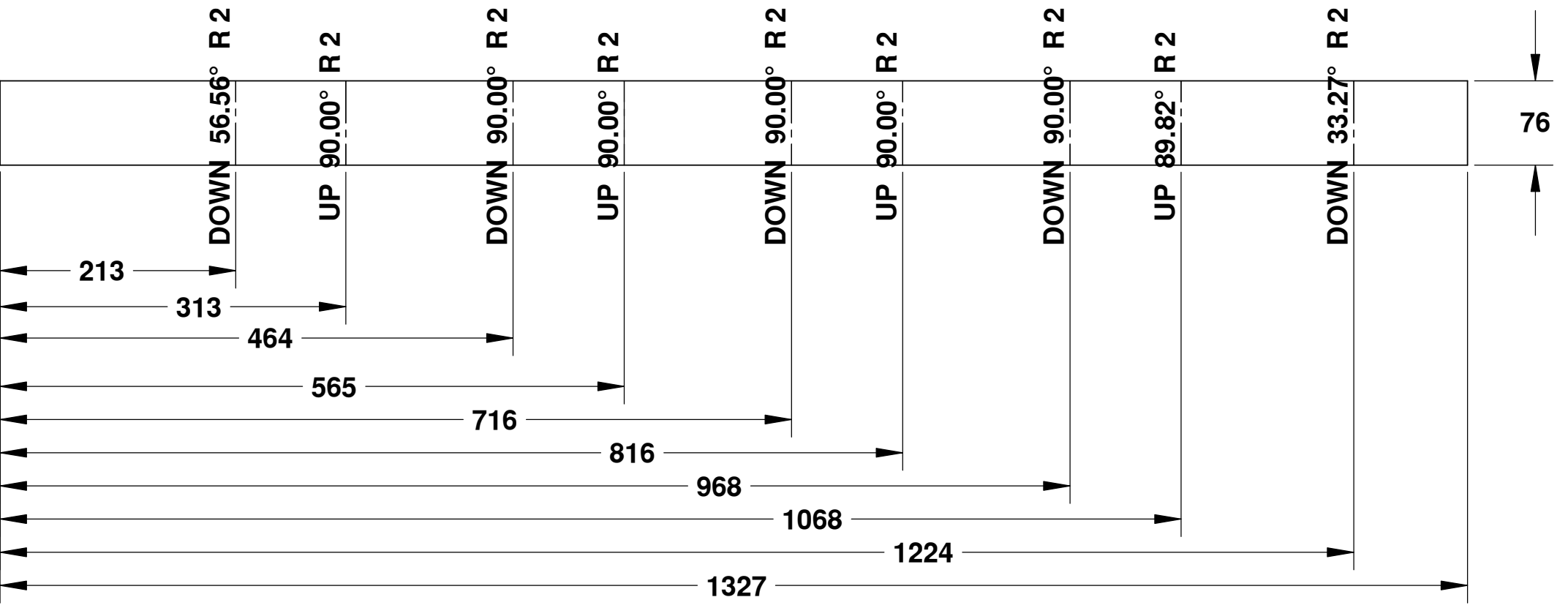

BACKING PLATE
SCALE: 1-5

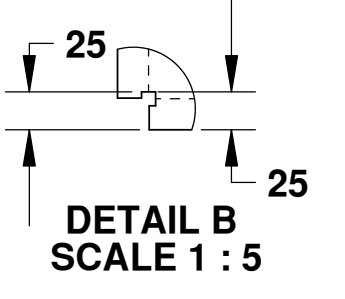

DETAIL B
SCALE 1 : 5

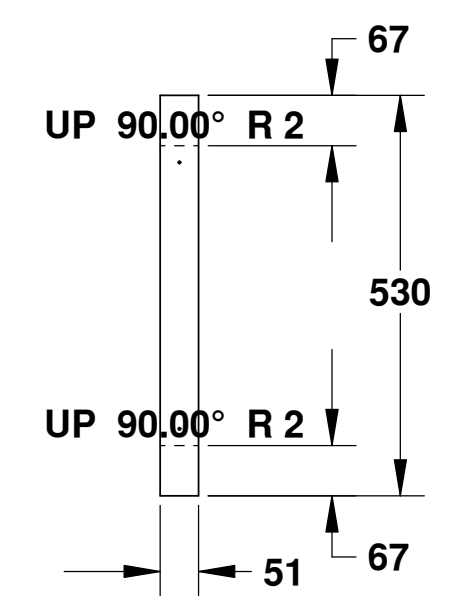

BREAKER BOX MOUNTS
SCALE: 1-10

PROPRIETARY AND CONFIDENTIAL
THE INFORMATION CONTAINED IN THIS DRAWING IS THE SOLE PROPERTY OF HER MAJESTY'S GOVERNMENT OF CANADA. ANY REPRODUCTION IN PART OR AS A WHOLE WITHOUT THE WRITTEN PERMISSION OF HER MAJESTY'S GOVERNMENT OF CANADA IS PROHIBITED.

UNLESS OTHERWISE SPECIFIED:		DATE	NAME
DIMENSIONS ARE IN INCHES	TOLERANCES:	DRAWN	WSL
FRACTIONAL: 1/16	ANGULAR: MAXIMUM BEND ±	CHECKED	EY
TWO PLACE DECIMAL ±	THREE PLACE DECIMAL ±	ENG APPR.	MB
		MFG APPR.	
INTERPRET GEOMETRIC TOLERANCING PER:	Q.A.	COMMENTS:	
MATERIAL:			
FINISH:			
NEXT ASSY:	USED ON:		
APPLICATION:	DO NOT SCALE DRAWING		

Fisheries & Oceans / Pêches et Océans
Small Craft Harbours Branch
ALUMINUM KIOSK
TITLE:
SIZE: **D** DWG. NO.: **AK15-005** REV:
SCALE: 1:10 WEIGHT: SHEET 1 OF 1

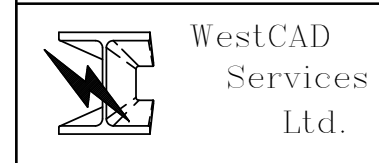

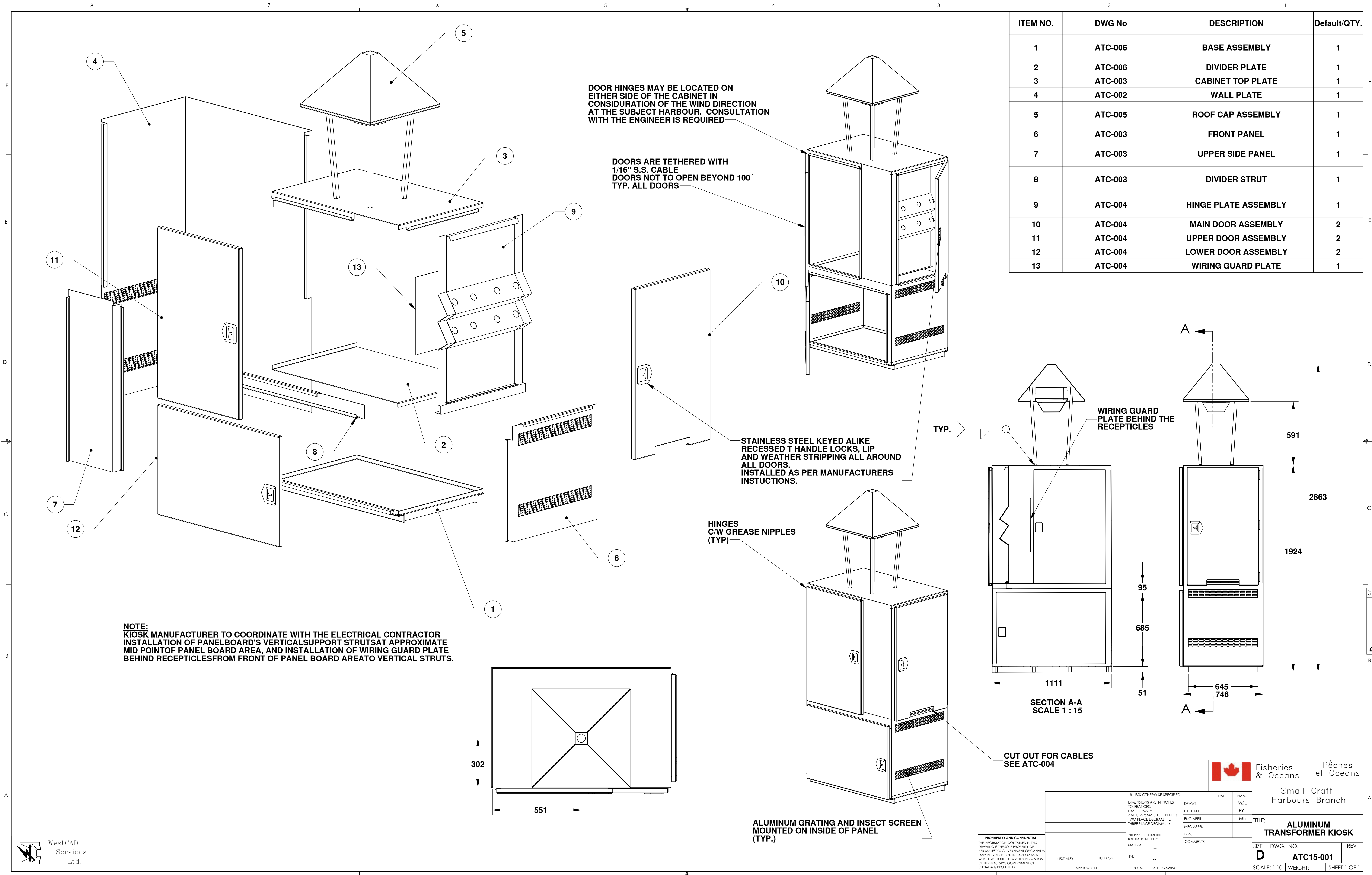

ITEM NO.	DWG No	DESCRIPTION	Default/QTY.
1	ATC-006	BASE ASSEMBLY	1
2	ATC-006	DIVIDER PLATE	1
3	ATC-003	CABINET TOP PLATE	1
4	ATC-002	WALL PLATE	1
5	ATC-005	ROOF CAP ASSEMBLY	1
6	ATC-003	FRONT PANEL	1
7	ATC-003	UPPER SIDE PANEL	1
8	ATC-003	DIVIDER STRUT	1
9	ATC-004	HINGE PLATE ASSEMBLY	1
10	ATC-004	MAIN DOOR ASSEMBLY	2
11	ATC-004	UPPER DOOR ASSEMBLY	2
12	ATC-004	LOWER DOOR ASSEMBLY	2
13	ATC-004	WIRING GUARD PLATE	1

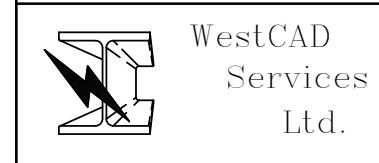

PROPRIETARY AND CONFIDENTIAL
 THE INFORMATION CONTAINED IN THIS DRAWING IS THE SOLE PROPERTY OF HER MAJESTY'S GOVERNMENT OF CANADA. ANY REPRODUCTION IN PART OR AS A WHOLE WITHOUT THE WRITTEN PERMISSION OF HER MAJESTY'S GOVERNMENT OF CANADA IS PROHIBITED.

UNLESS OTHERWISE SPECIFIED:	DATE	NAME
DIMENSIONS ARE IN INCHES		
TOLERANCES:		
FRACTIONAL: ±	DRAWN	WSL
ANGULAR: MATCHES BEND ±	CHECKED	EY
TWO PLACE DECIMAL: ±	ENG APPR.	MB
THREE PLACE DECIMAL: ±	MFG APPR.	
INTERPRET GEOMETRIC TOLERANCING PER:	O.A.	
MATERIAL:	COMMENTS:	
FINISH:		
NEXT ASSY:	APPLICATION	DO NOT SCALE DRAWING
USED ON:		

Fisheries & Oceans / Pêches et Océans

Small Craft Harbours Branch

ALUMINUM TRANSFORMER KIOSK

SCALE: 1:10 | WEIGHT: | SHEET 1 OF 1

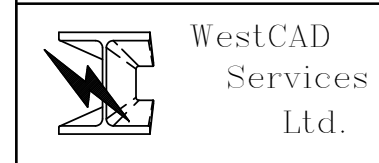
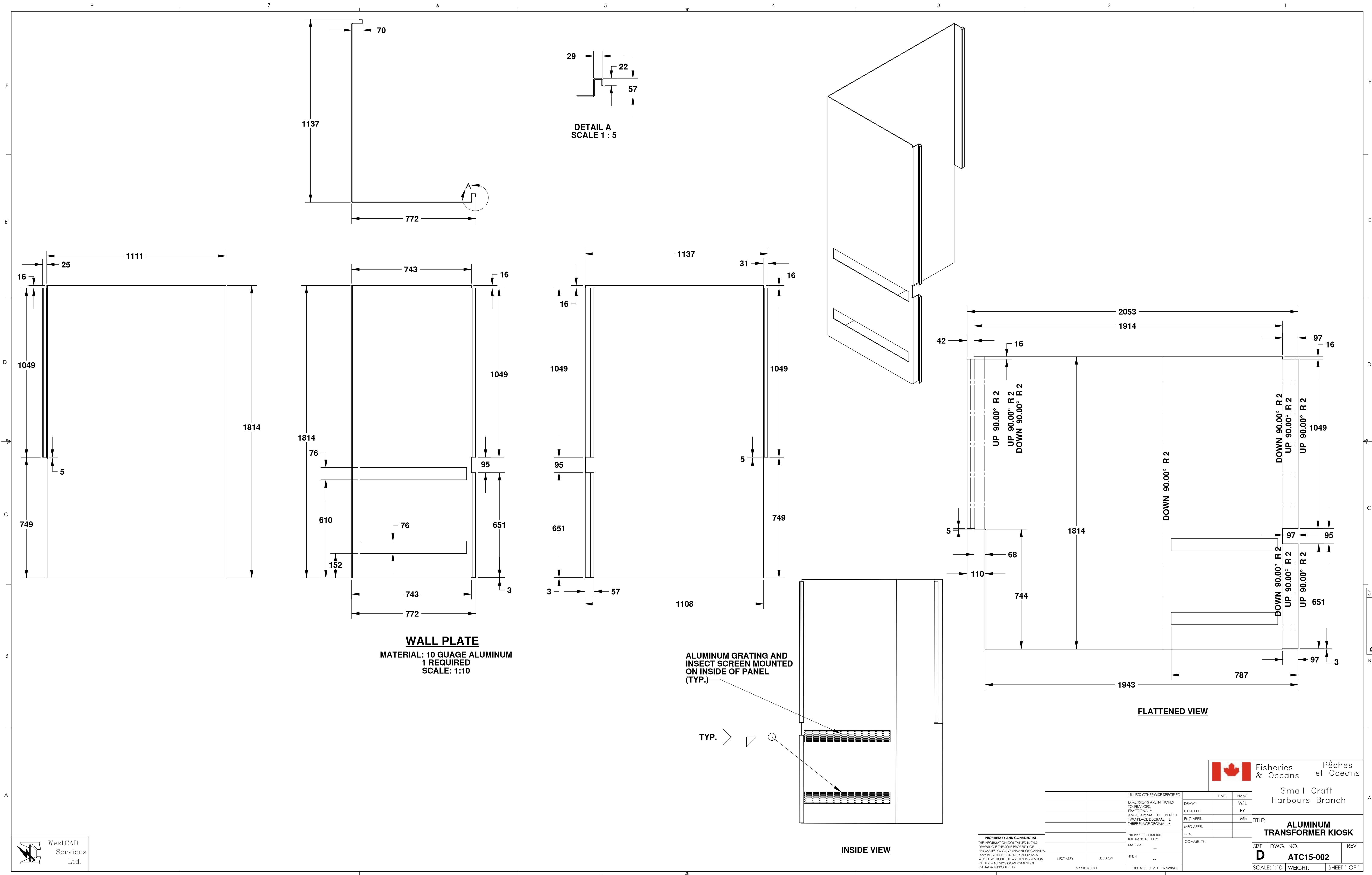

PROPRIETARY AND CONFIDENTIAL
 THE INFORMATION CONTAINED IN THIS DRAWING IS THE SOLE PROPERTY OF HER MAJESTY'S GOVERNMENT OF CANADA. ANY REPRODUCTION IN PART OR AS A WHOLE WITHOUT THE WRITTEN PERMISSION OF HER MAJESTY'S GOVERNMENT OF CANADA IS PROHIBITED.

UNLESS OTHERWISE SPECIFIED:		DATE	NAME
DIMENSIONS ARE IN INCHES	DRAWN		WLSL
TOLERANCES:	CHECKED		EY
FRACTIONAL: 1/16	ENG APPR.		MB
ANGULAR: MATCH BEND 1	MFG APPR.		
TWO PLACE DECIMAL ±			
THREE PLACE DECIMAL ±			
INTERPRET GEOMETRIC TOLERANCING PER:	COMMENTS:		
MATERIAL: --	O.A.		
FINISH: --	DO NOT SCALE DRAWING		
NEXT ASSY:	USED ON:		

Fisheries & Oceans / Pêches et Océans
 Small Craft Harbours Branch

TITLE: ALUMINUM TRANSFORMER KIOSK	
SIZE: D	DWG. NO. ATC15-002
SCALE: 1:10	WEIGHT: SHEET 1 OF 1

FOR REFERENCE ONLY

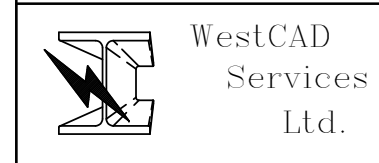
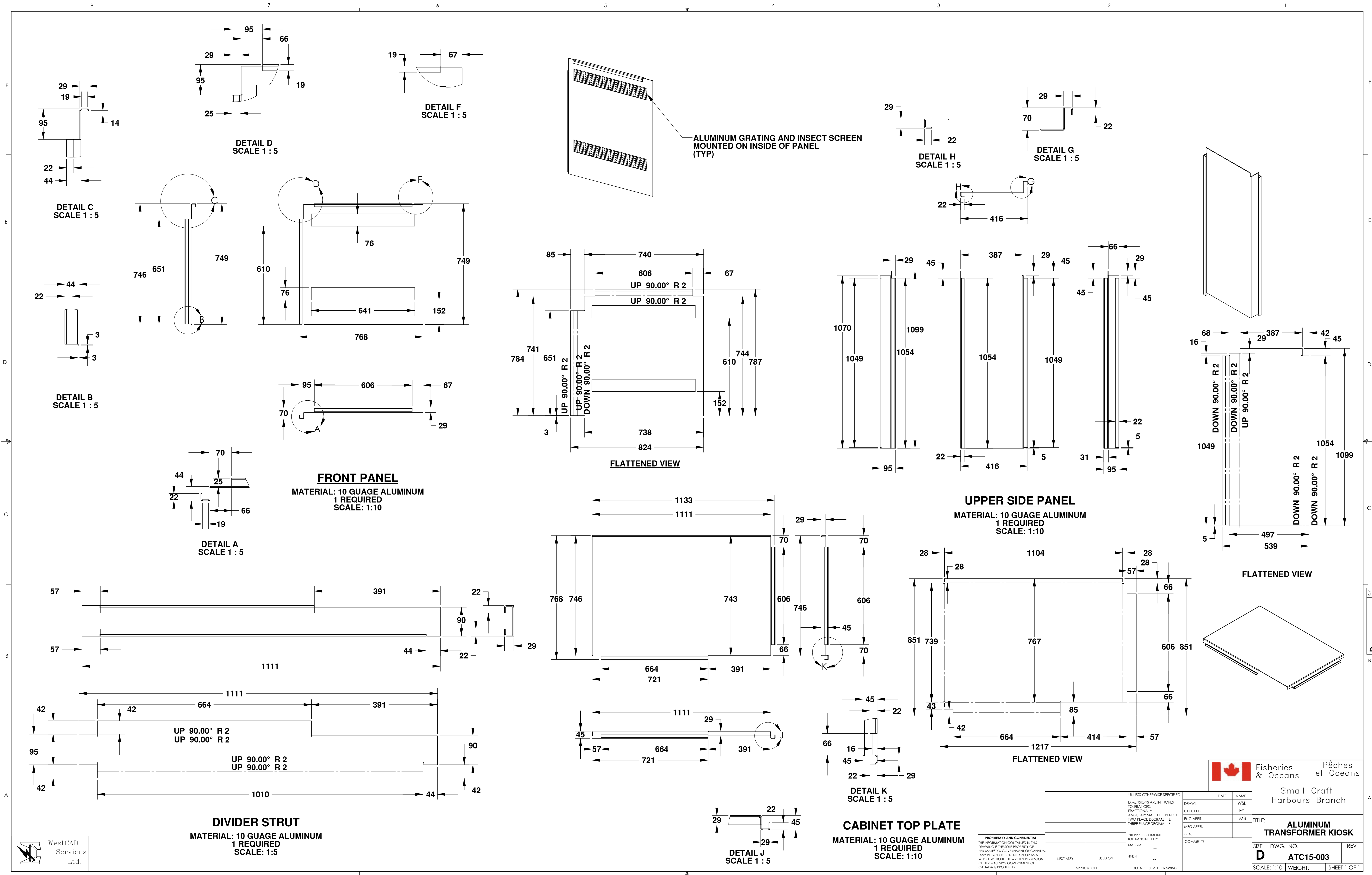

UNLESS OTHERWISE SPECIFIED:		DATE	NAME
DIMENSIONS ARE IN INCHES	TOLERANCES:		
FRACTIONAL: L	DRAWN		WSL
ANGULAR: MACH 1/2 BEND 1	CHECKED		EY
TWO PLACE DECIMAL ±	ENG APPR.		MB
THREE PLACE DECIMAL ±	MFG APPR.		
INTERPRET GEOMETRIC TOLERANCING PER:	COMMENTS:		
MATERIAL: --	O.A.		
FINISH: --			
NEXT ASSY:	USED ON:	APPLICATION: DO NOT SCALE DRAWING	

TITLE: ALUMINUM TRANSFORMER KIOSK		
SIZE: D	DWG. NO.: ATC15-003	REV
SCALE: 1:10	WEIGHT:	SHEET 1 OF 1

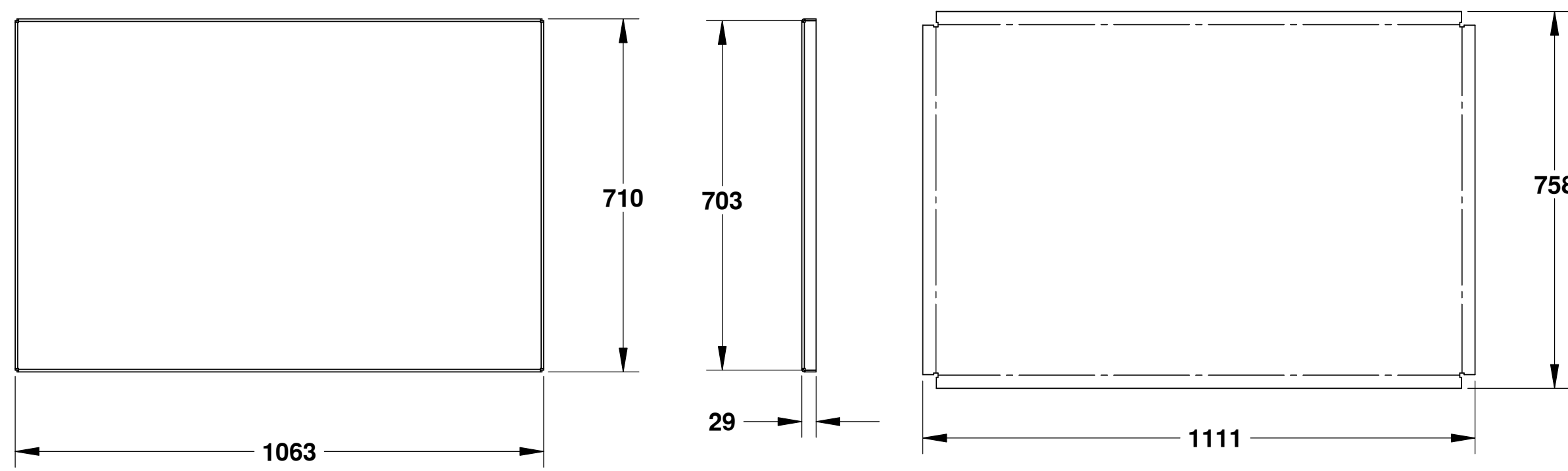

LOWER DOOR PANEL
 MATERIAL: 10 GAUGE ALUMINUM
 1 REQUIRED
 SCALE: 1:10

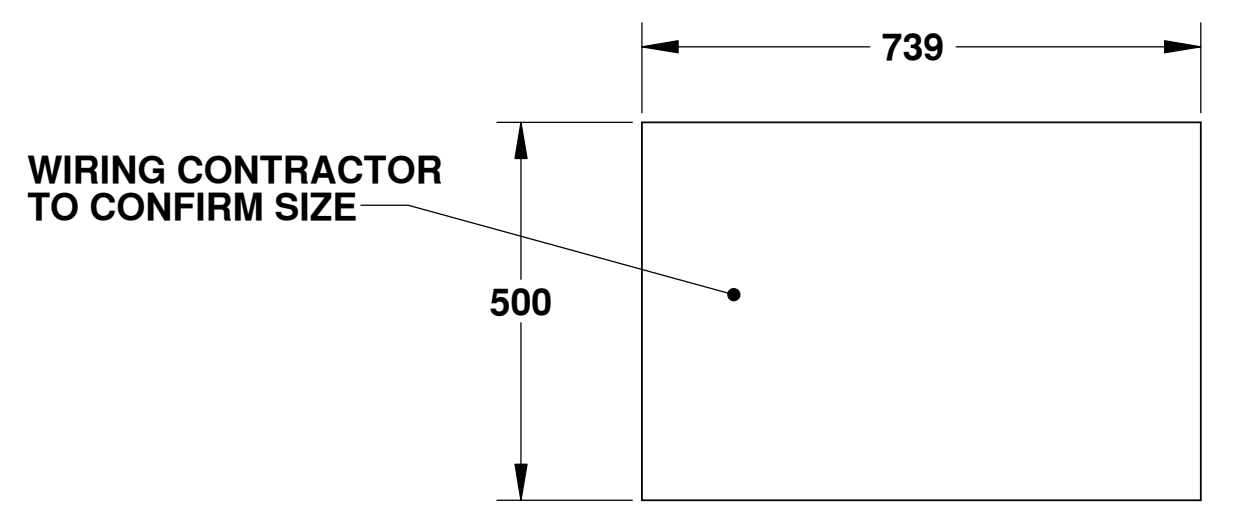

WIRING GUARD PLATE
 MATERIAL: 10 GAUGE ALUMINUM
 1 REQUIRED
 SCALE: 1:10

300 x 50 CUTOUT FOR CABLES. ROLL EDGES MIN. 200° BACK ON ITS SELF

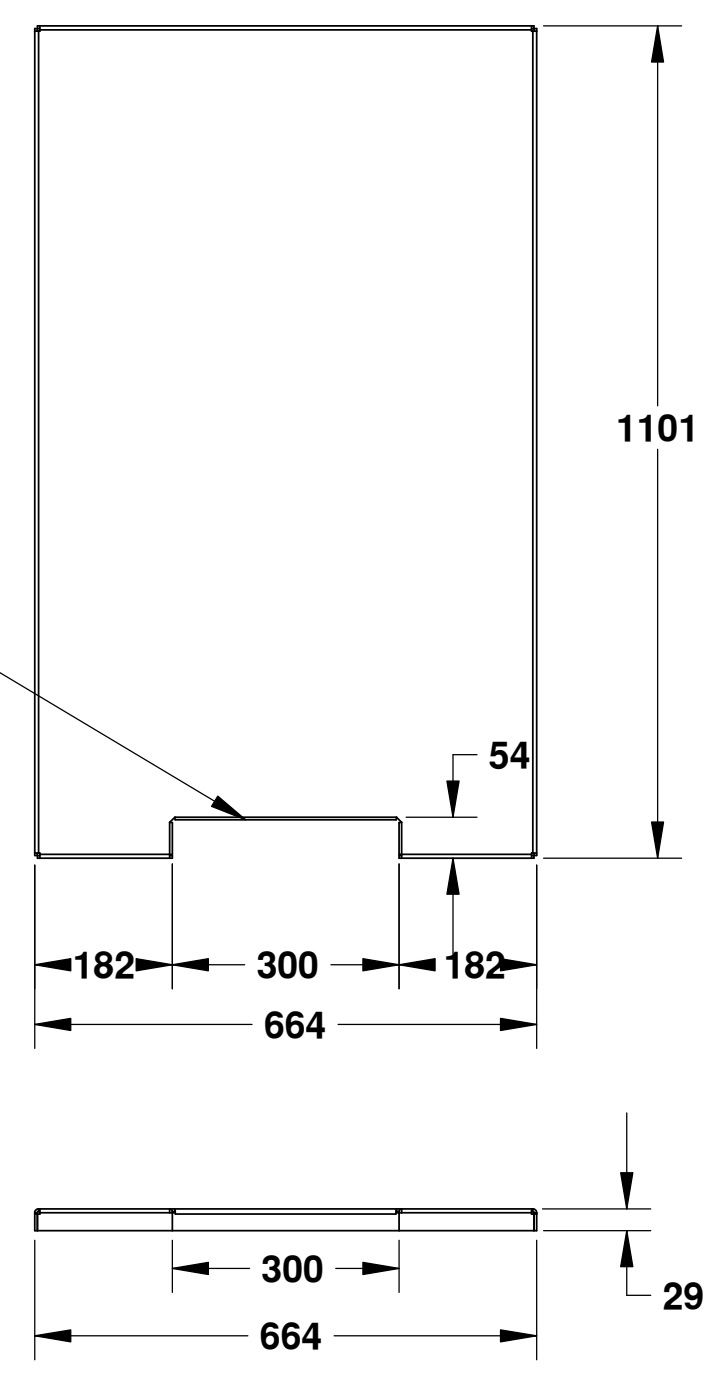

UPPER DOOR PANEL
 MATERIAL: 10 GAUGE ALUMINUM
 1 REQUIRED
 SCALE: 1:10

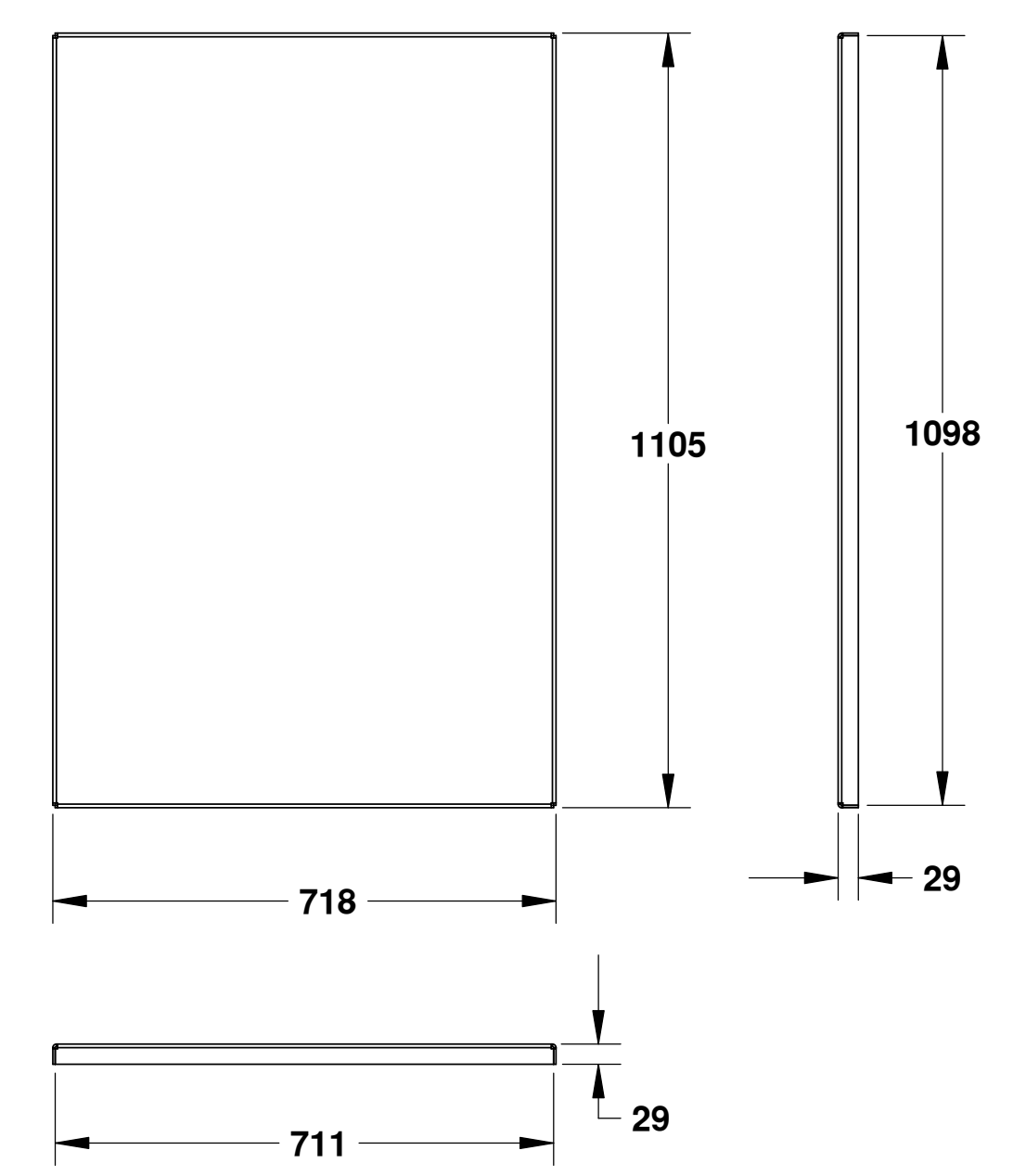
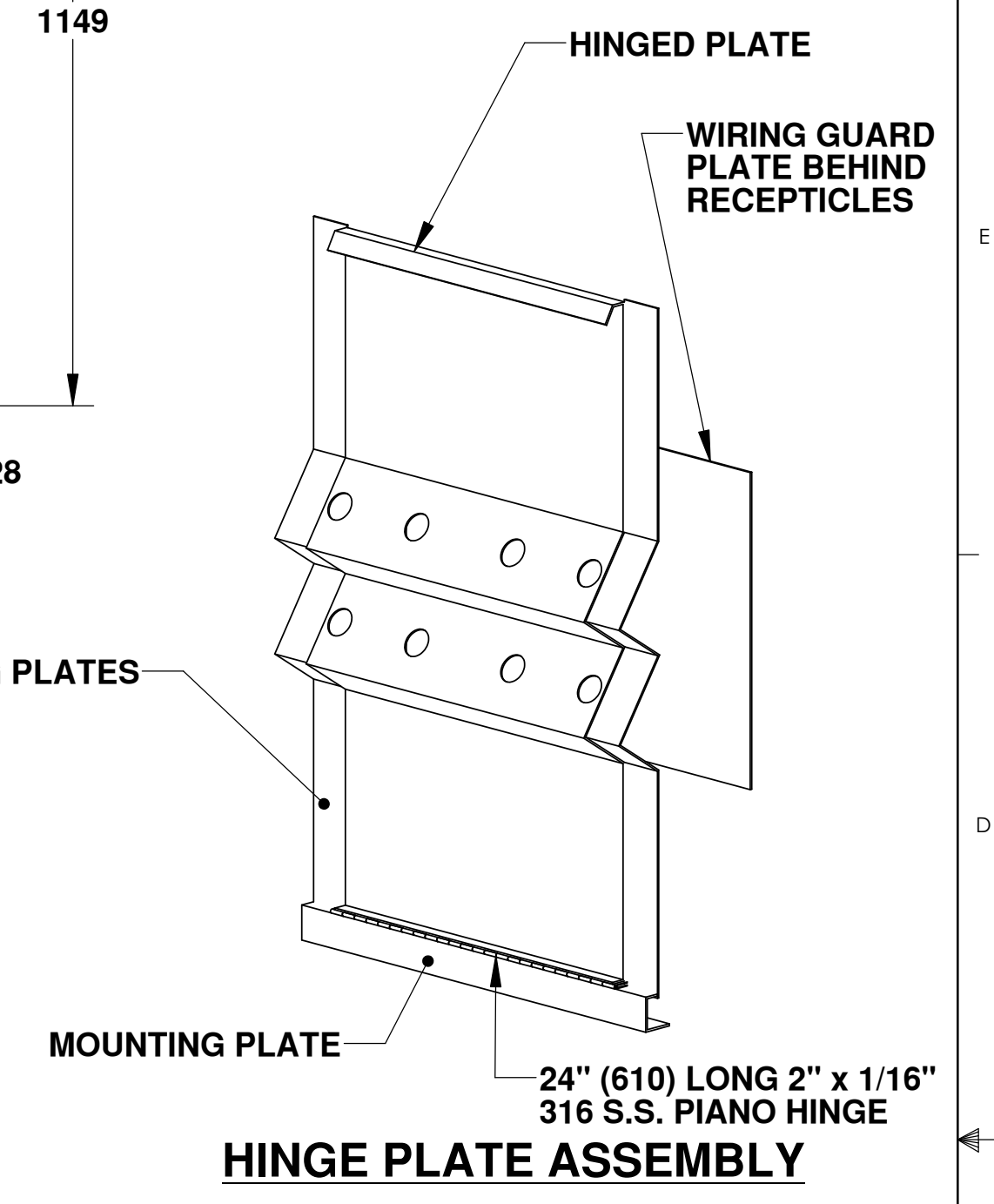
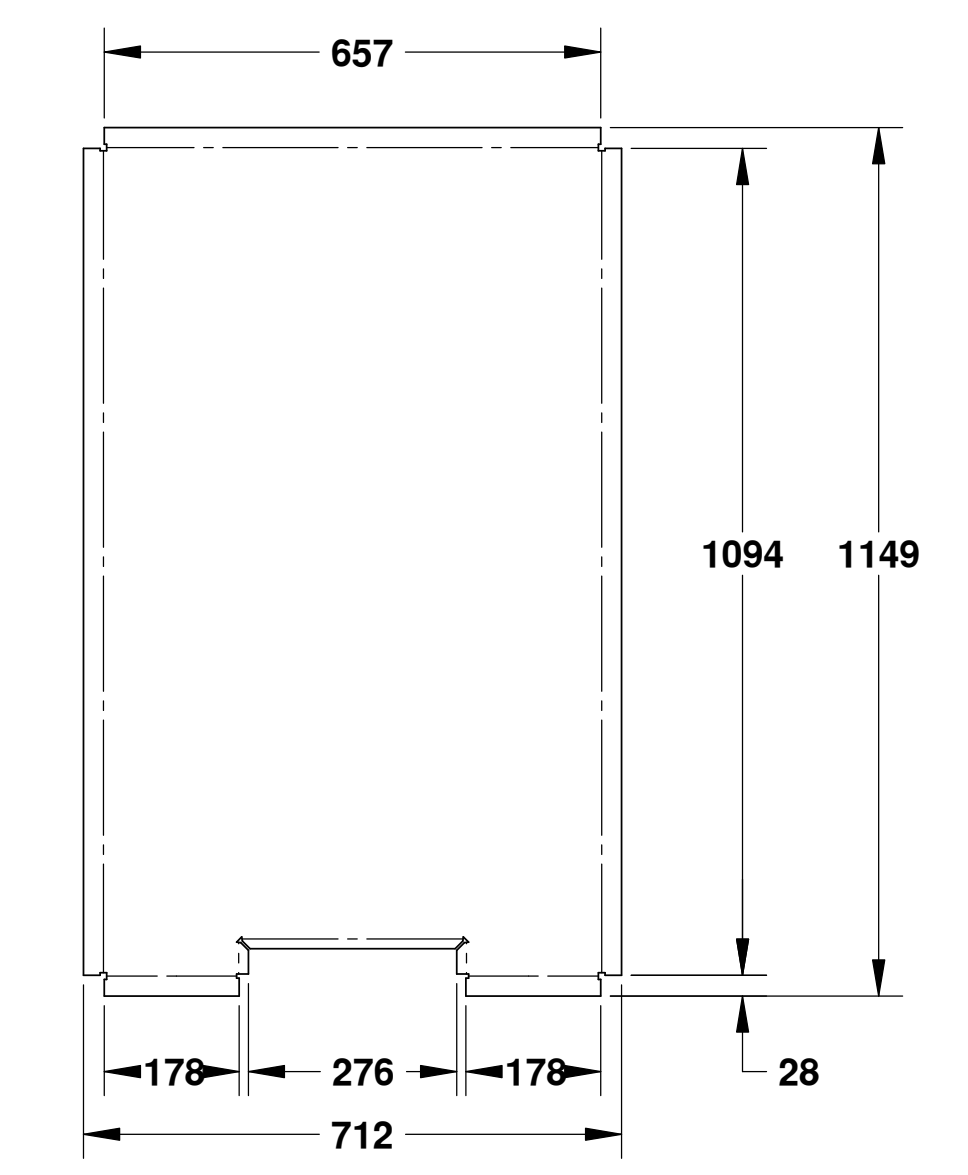

MAIN DOOR PANEL
 MATERIAL: 10 GAUGE ALUMINUM
 1 REQUIRED
 SCALE: 1:10

ELECTRICAL CONTRACTOR TO CONFIRM SIZE OF CUTOUTS REQUIRED AND MOUNTING HOLES FOR RECEPTILES (TYP.)

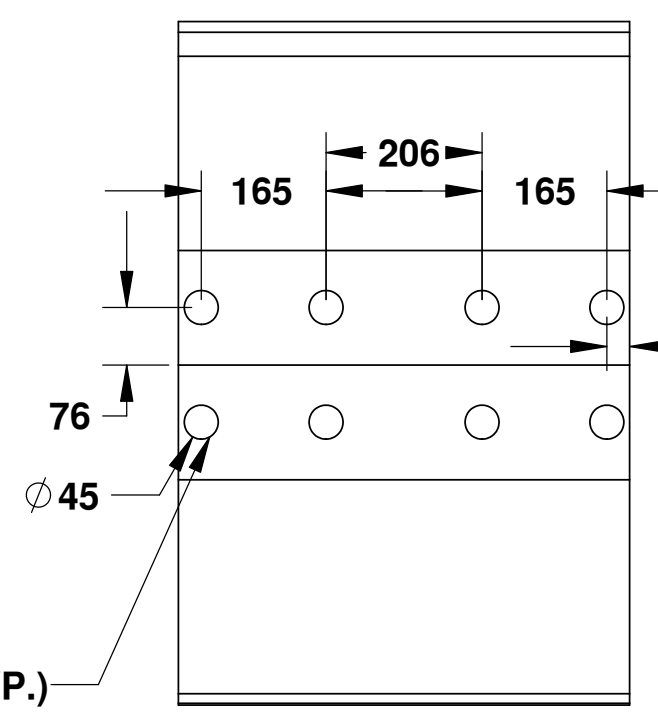

VIEW 1

HINGED PLATE
 MATERIAL: 10 GAUGE ALUMINUM
 1 REQUIRED
 SCALE: 1:10

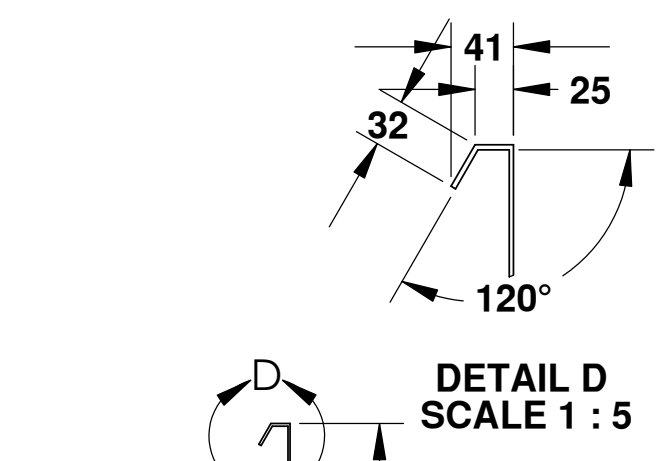

DETAIL D
 SCALE 1 : 5

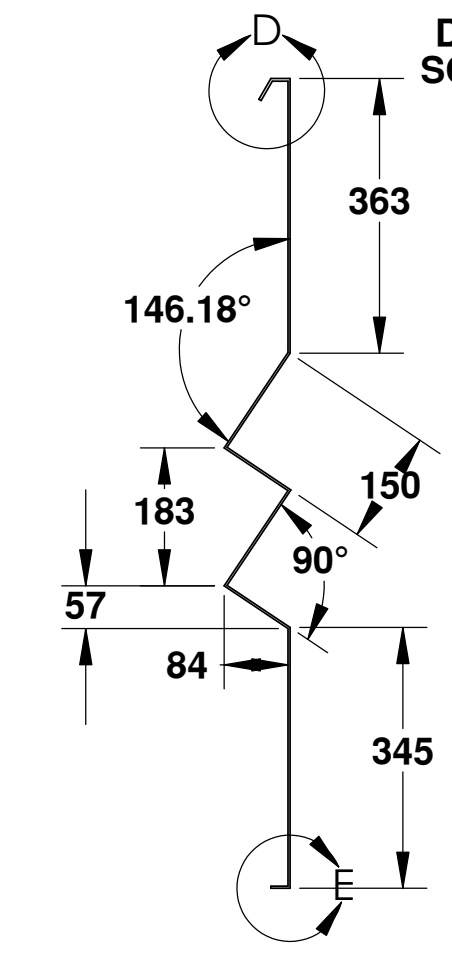

DETAIL E
 SCALE 1 : 5

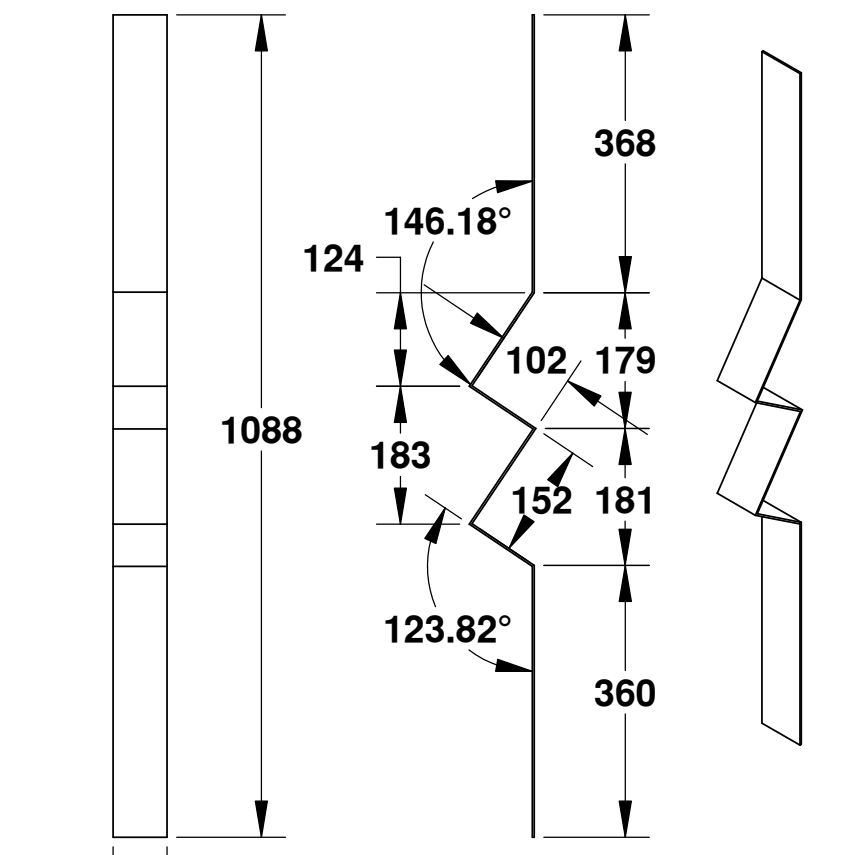
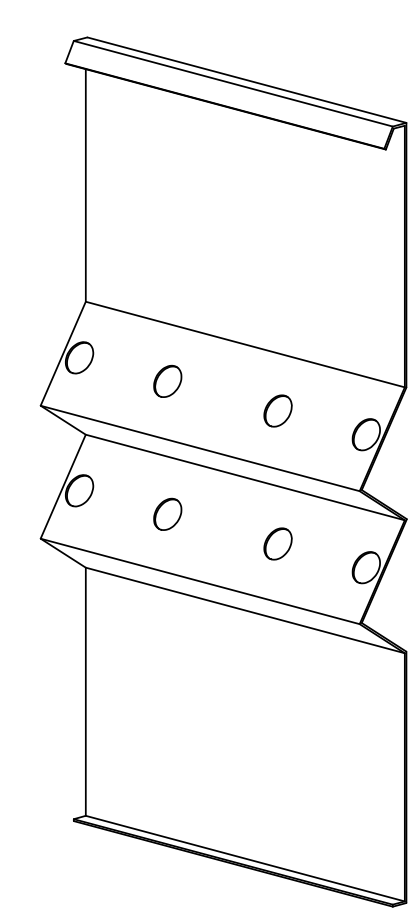

BACKING PLATE
 MATERIAL: 12 GAUGE ALUMINUM
 1 REQUIRED
 SCALE: 1:10

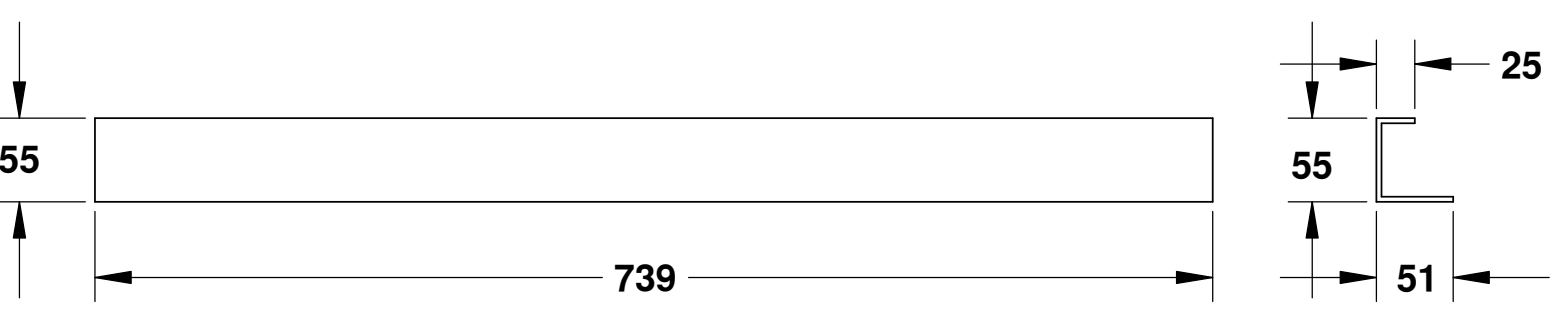

MOUNTING PLATE
 MATERIAL: 10 GAUGE ALUMINUM
 1 REQUIRED
 SCALE: 1:10

Fisheries & Oceans / Pêches et Océans
 Small Craft Harbours Branch

UNLESS OTHERWISE SPECIFIED:		DATE	NAME
DIMENSIONS ARE IN INCHES	TOLERANCES:	DRAWN	WSL
FRACTIONAL: L	ANGULAR: MACH: ± BEND ±	CHECKED	EY
TWO PLACE DECIMAL: ±	THREE PLACE DECIMAL: ±	ENG APPR.	MB
		MFG APPR.	
INTERPRET GEOMETRIC TOLERANCING PER:		Q.A.	
MATERIAL: --		COMMENTS:	
FINISH: --			
NEXT ASSY:	USED ON:		
APPLICATION:	DO NOT SCALE DRAWING		

TITLE: ALUMINUM TRANSFORMER KIOSK	
SIZE: D	DWG. NO.: ATC15-004
SCALE: 1:10	WEIGHT: SHEET 1 OF 1

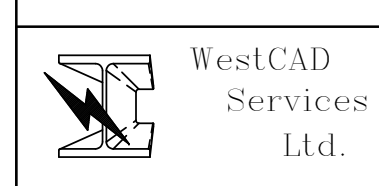

PROPRIETARY AND CONFIDENTIAL
 THE INFORMATION CONTAINED IN THIS DRAWING IS THE SOLE PROPERTY OF HER MAJESTY'S GOVERNMENT OF CANADA. ANY REPRODUCTION IN PART OR AS A WHOLE WITHOUT THE WRITTEN PERMISSION OF HER MAJESTY'S GOVERNMENT OF CANADA IS PROHIBITED.

FOR REFERENCE ONLY

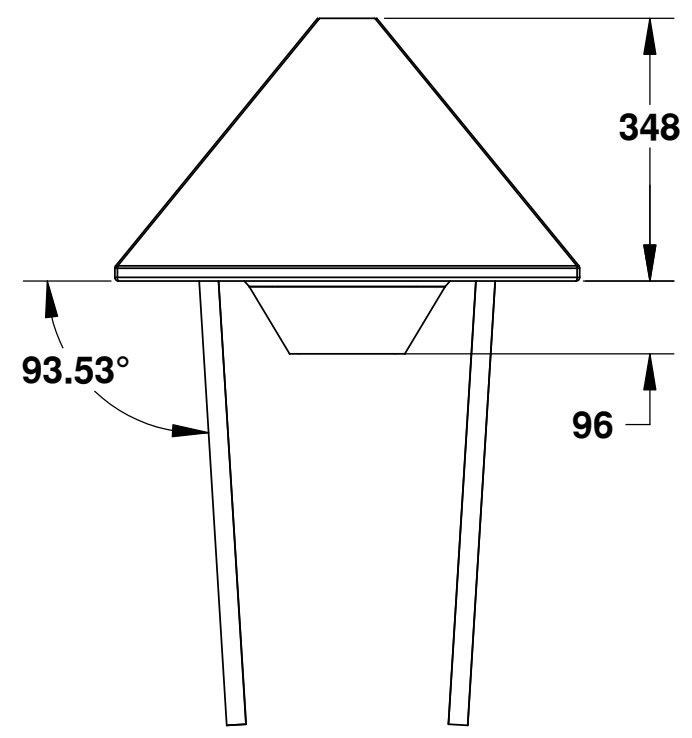
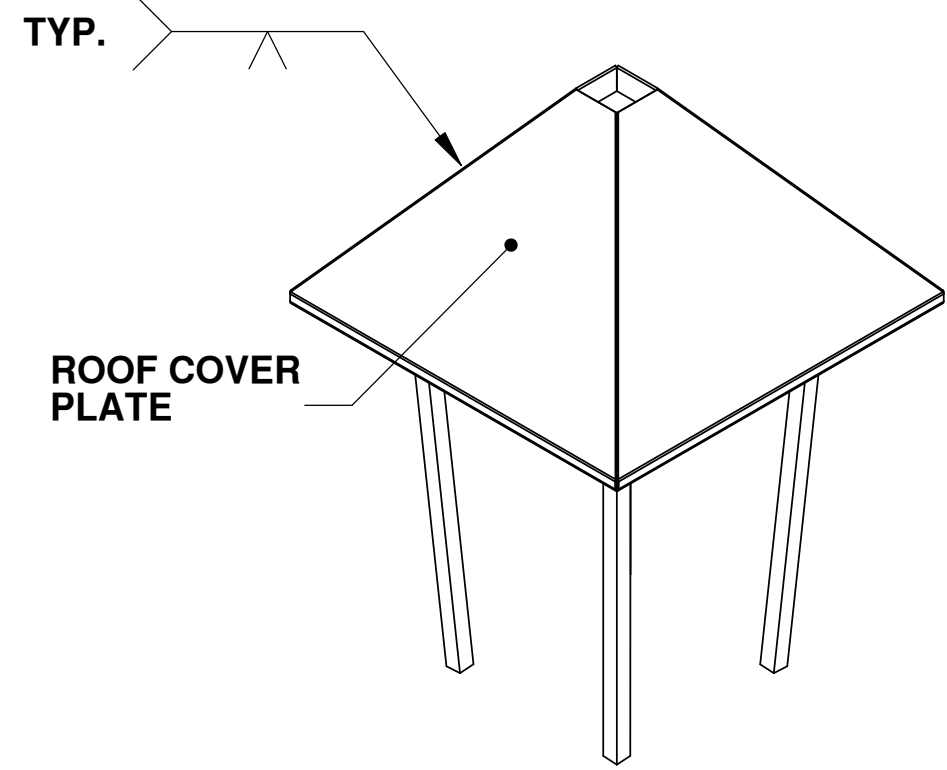
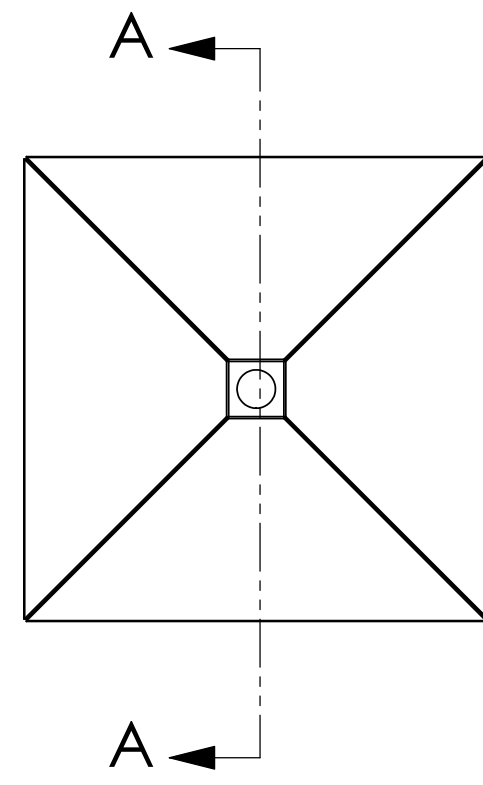

ROOF CAP ASSEMBLY
1 REQUIRED
SCALE: 1:10

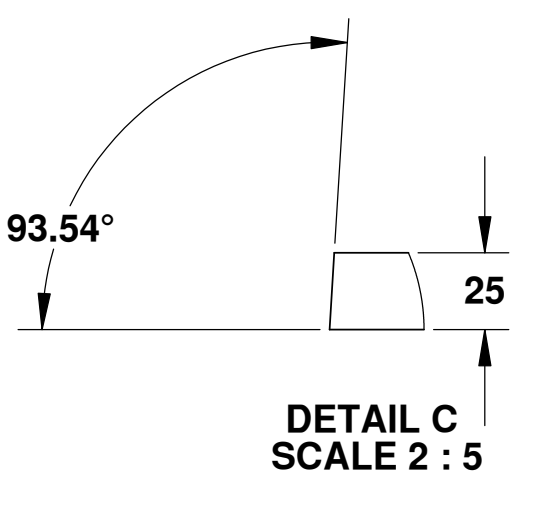

DETAIL C
SCALE 2:5

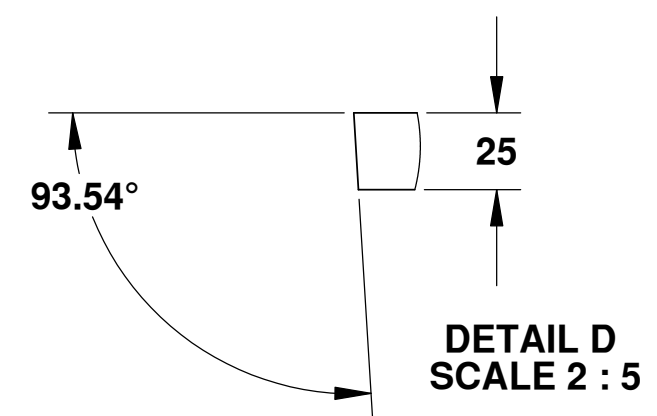

DETAIL D
SCALE 2:5

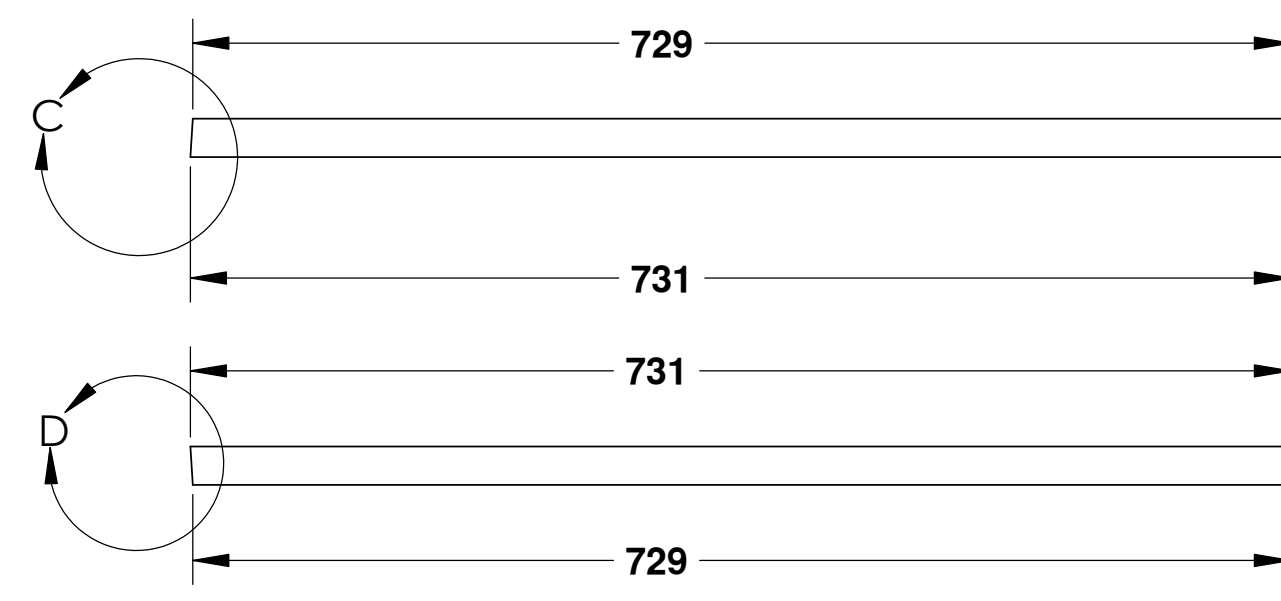

ROOF SUPPORT
MATERIAL: ALUMINUM SQUARE TUBE
1 REQUIRED
SCALE: 1:5

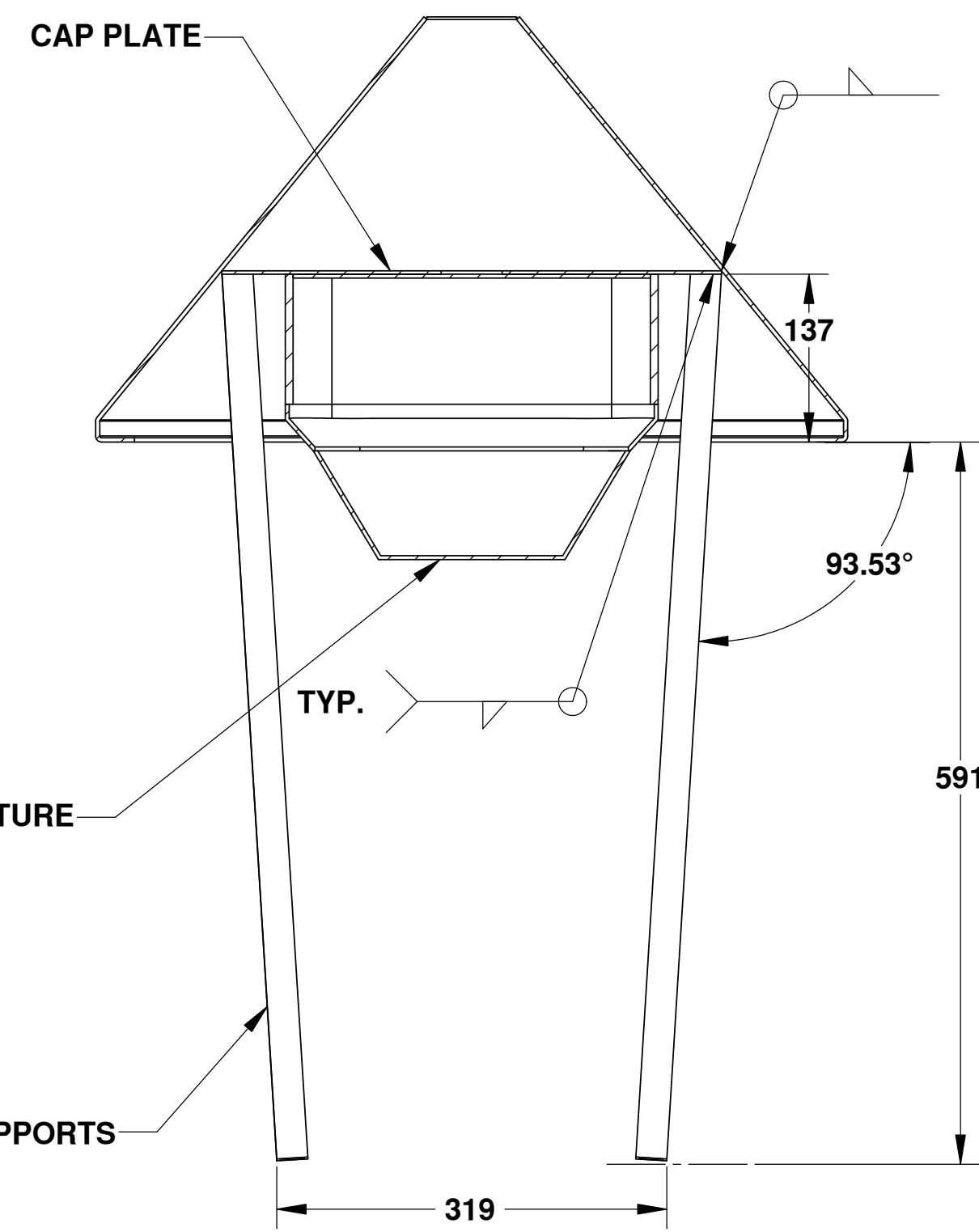

SECTION A-A
SCALE 1:5

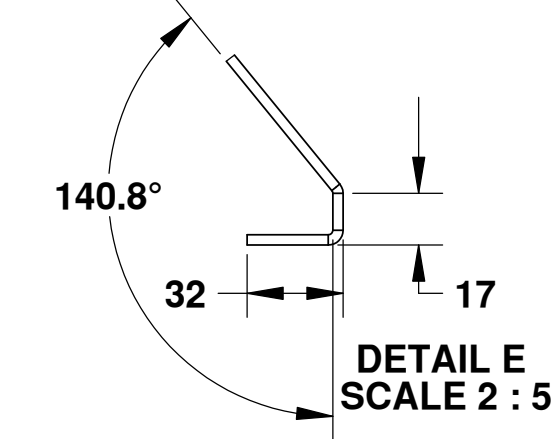

DETAIL E
SCALE 2:5

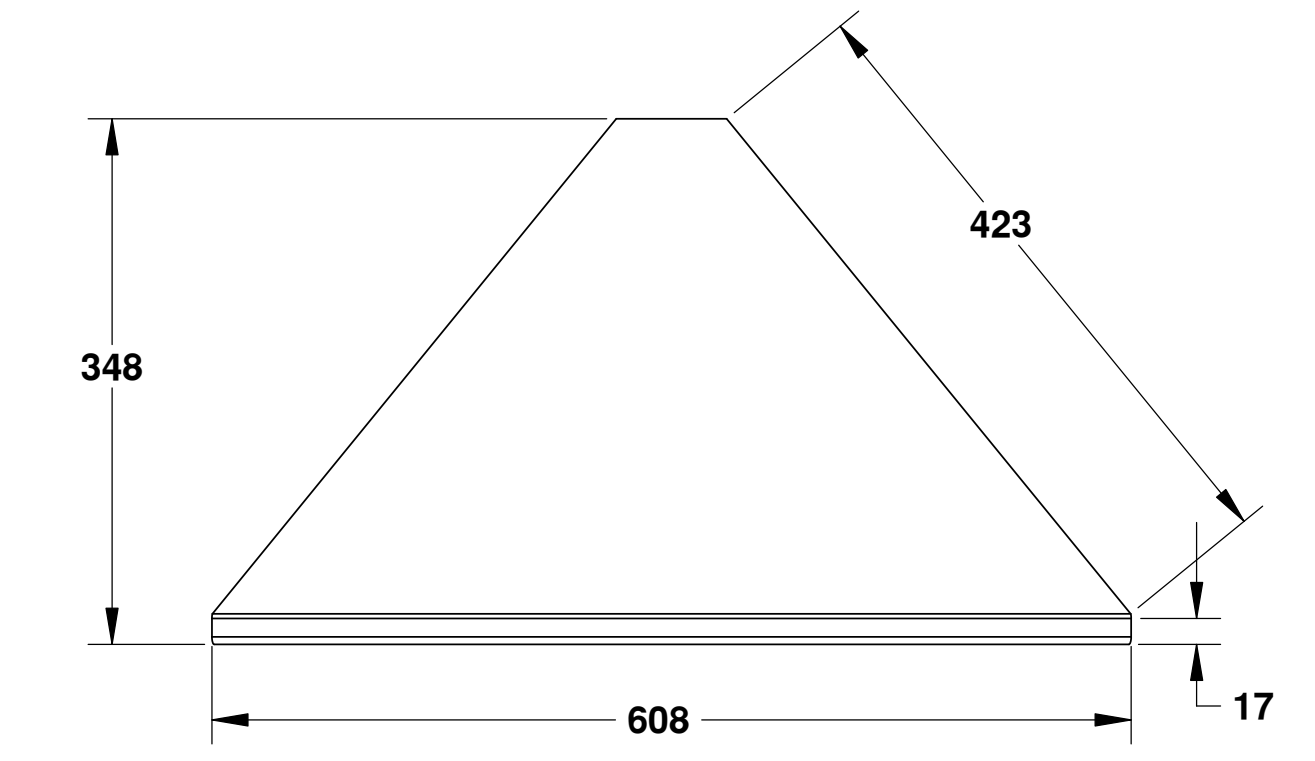
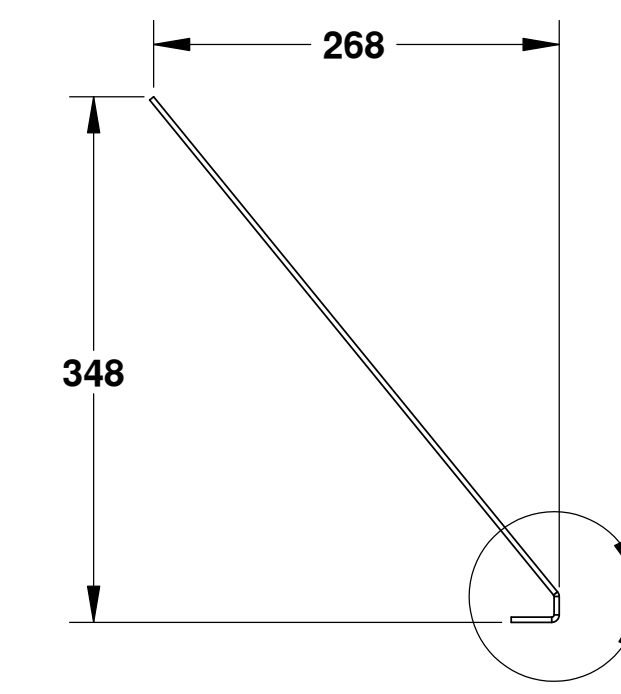

ROOF COVER PLATE
MATERIAL: 10 GAUGE ALUMINUM
1 REQUIRED
SCALE: 1:5

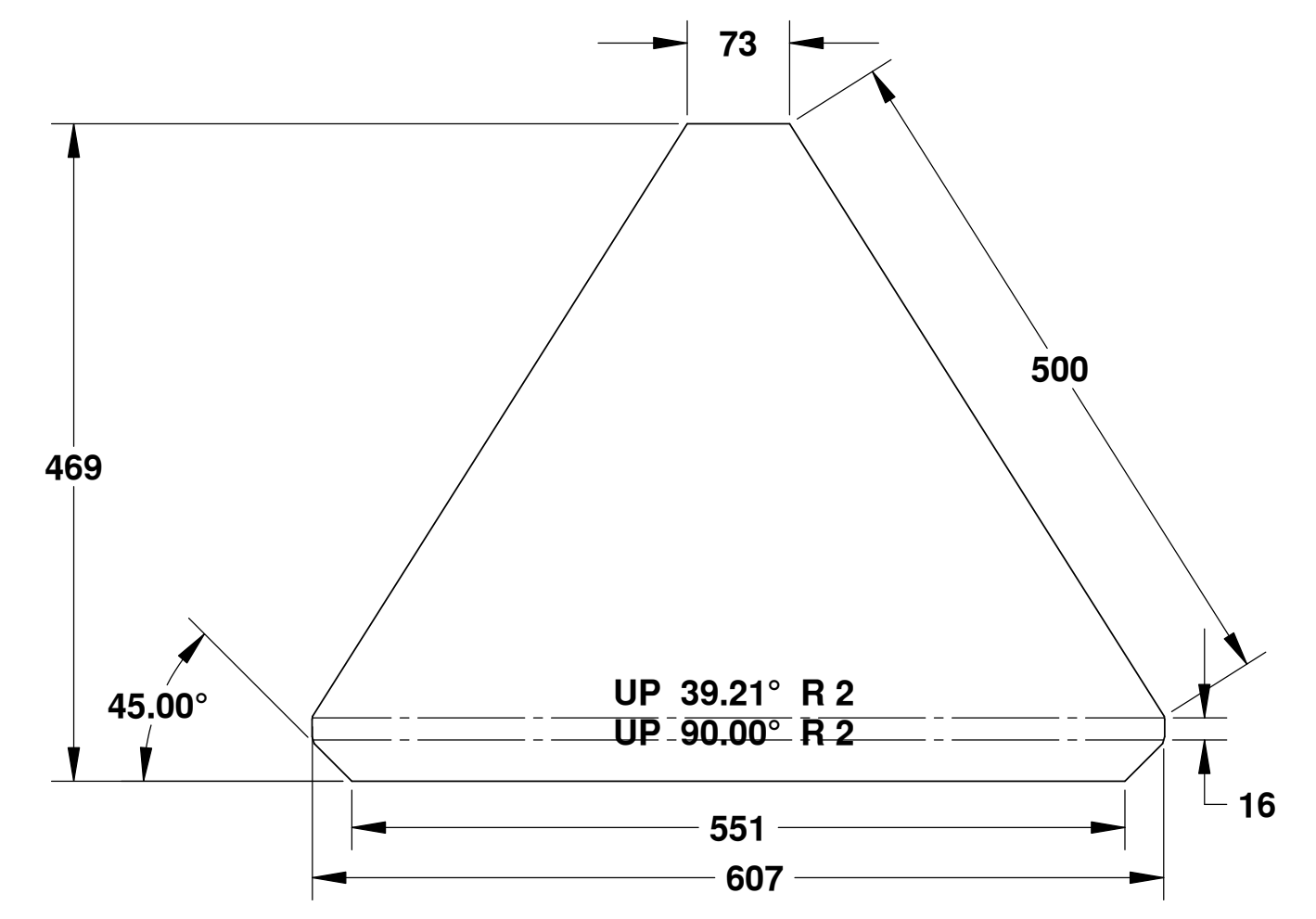

ELECTRICAL CONTRACTOR TO CONFIRM SIZE OF CUTOUTS REQUIRED TO MOUNT LUMINAIRE

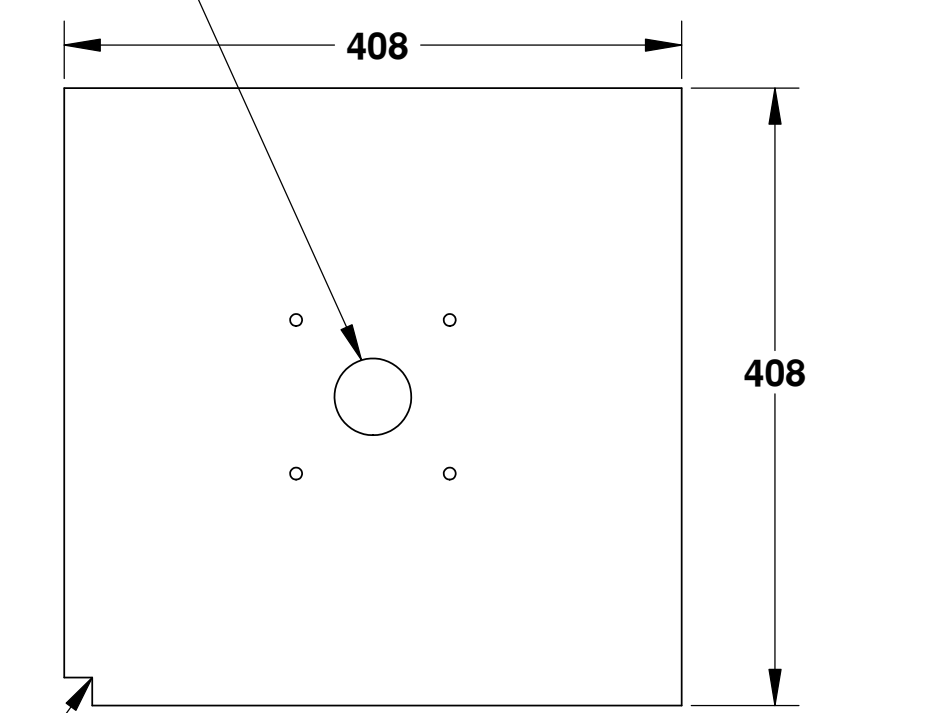

CAP PLATE
MATERIAL: 10 GAUGE ALUMINUM
1 REQUIRED
SCALE: 1:5

WIREWAY CUTOUT AT ROOF SUPPORT (ONE ONLY) FOR WIRES ROUTED TO PHOTOCELL AND LUMINAIRE (LOCATE AT THE ROOF SUPPORT THAT IS LOCATED OVER PANEL BOARD AREA) IF REQUIRED.

Fisheries & Oceans / Pêches et Océans
Small Craft Harbours Branch

UNLESS OTHERWISE SPECIFIED:		DATE	NAME
DIMENSIONS ARE IN INCHES	DRAWN		WSL
TOLERANCES:	CHECKED		EY
FRACTIONAL: L	ENG APPR.		MB
ANGULAR: MATCHES BEND 1	MFG APPR.		
TWO PLACE DECIMAL ±			
THREE PLACE DECIMAL ±			
INTERPRET GEOMETRIC TOLERANCING PER:	COMMENTS:		
MATERIAL: --	O.A.		
FINISH: --			
NEXT ASSY:	USED ON:		
APPLICATION:	DO NOT SCALE DRAWING		

TITLE: ALUMINUM TRANSFORMER KIOSK		
SIZE: D	DWG. NO.: ATC15-005	REV:
SCALE: 1:10	WEIGHT:	SHEET 1 OF 1

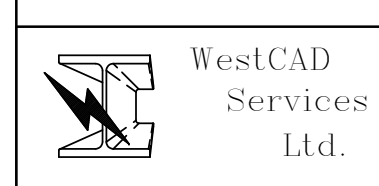

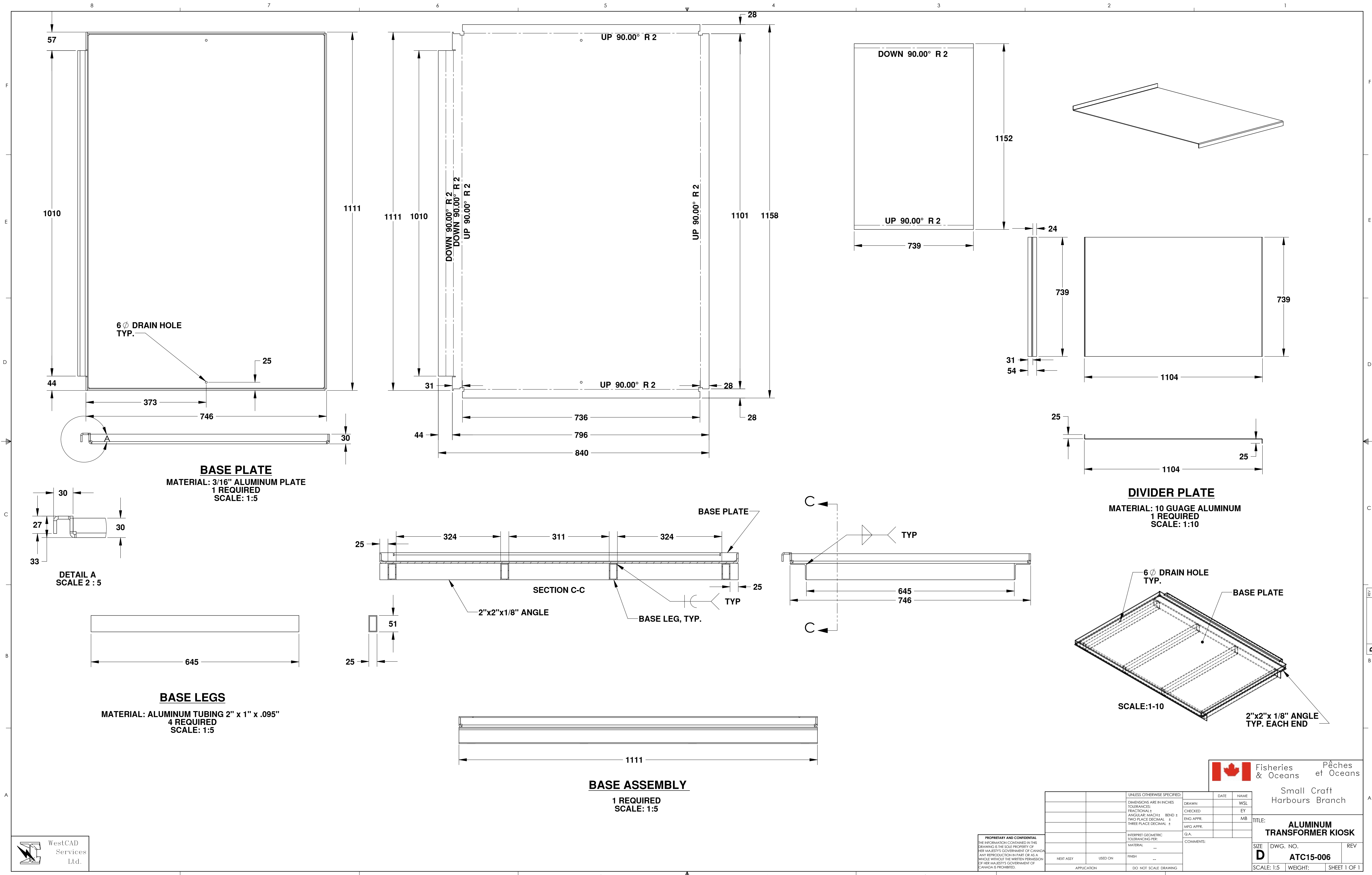

BASE PLATE
 MATERIAL: 3/16" ALUMINUM PLATE
 1 REQUIRED
 SCALE: 1:5

DIVIDER PLATE
 MATERIAL: 10 GAUGE ALUMINUM
 1 REQUIRED
 SCALE: 1:10

BASE LEGS
 MATERIAL: ALUMINUM TUBING 2" x 1" x .095"
 4 REQUIRED
 SCALE: 1:5

BASE ASSEMBLY
 1 REQUIRED
 SCALE: 1:5

Fisheries & Oceans / Pêches et Océans
 Small Craft Harbours Branch

UNLESS OTHERWISE SPECIFIED:		DATE	NAME
DIMENSIONS ARE IN INCHES	TOLERANCES:	DRAWN	WSL
FRACTIONAL: ±	ANGULAR: MACH 1/2 BEND ±	CHECKED	EY
TWO PLACE DECIMAL: ±	THREE PLACE DECIMAL: ±	ENG APPR.	MB
		MFG APPR.	
INTERPRET GEOMETRIC TOLERANCING PER:		Q.A.	
MATERIAL: --		COMMENTS:	
FINISH: --			
NEXT ASSY:	USED ON:		
APPLICATION:	DO NOT SCALE DRAWING		

TITLE: **ALUMINUM TRANSFORMER KIOSK**

SIZE: **D** DWG. NO.: **ATC15-006** REV: **1**

SCALE: 1:5 WEIGHT: SHEET 1 OF 1

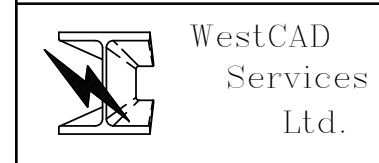

PROPRIETARY AND CONFIDENTIAL
 THE INFORMATION CONTAINED IN THIS DRAWING IS THE SOLE PROPERTY OF HER MAJESTY'S GOVERNMENT OF CANADA. ANY REPRODUCTION IN PART OR AS A WHOLE WITHOUT THE WRITTEN PERMISSION OF HER MAJESTY'S GOVERNMENT OF CANADA IS PROHIBITED.