



National Defence

Défense nationale

National Defence Headquarters
Ottawa, Ontario
K1A 0K2

Quartier général de la Défense nationale
Ottawa (Ontario)
K1A 0K2

REQUEST FOR PROPOSAL DEMANDE DE PROPOSITION

RETURN BIDS TO: RETOURNER LES SOUMISSIONS À :

Sarah Gale DLP 7-2-5-4
[Sarah.gale-mouldey@forces.gc.ca](mailto:sarah.gale-mouldey@forces.gc.ca)

Proposal To: National Defence Canada

We hereby offer to sell to Her Majesty the Queen in right of Canada, in accordance with the terms and conditions set out herein, referred to herein or attached hereto, the goods and services listed herein and on any attached sheets at the price(s) set out therefore.

Proposition à : Défense nationale Canada

Nous offrons par la présente de vendre à Sa Majesté la Reine du chef du Canada, aux conditions énoncées ou incluses par référence dans la présente et aux annexes ci-jointes, les biens et services énumérés ici et sur toute feuille ci-annexée, au(x) prix indique(s).

Solicitation Closes – L’invitation prend fin

At – à : 14 :00 Eastern Standard Time

On - le : April 19, 2022

Title/Titre Vibration Ammunition Testing	Solicitation No – N° de l’invitation W8486-228052/A
Date of Solicitation – Date de l’invitation April 19, 2022	
Address Enquiries to – Adresser toutes questions à Sarah Gale DLP 7-2-5-4 sarah.gale-mouldey@forces.gc.ca	
Telephone No. – N° de téléphone 613-324-7736	FAX No – N° de fax N/A
Destination As per Statement of Work at Annex A.	

Instructions:

Municipal taxes are not applicable. Unless otherwise specified herein all prices quoted must include all applicable Canadian customs duties, GST/HST, excise taxes and are to be delivered Delivery Duty Paid including all delivery charges to destination(s) as indicated. The amount of the Goods and Services Tax/Harmonized Sales Tax is to be shown as a separate item.

Instructions: Les taxes municipales ne s'appliquent pas. Sauf indication contraire, les prix indiqués doivent comprendre les droits de douane canadiens, la TPS/TVH et la taxe d'accise. Les biens doivent être livrés « rendu droits acquittés », tous frais de livraison compris, à la ou aux destinations indiquées. Le montant de la taxe sur les produits et services/taxe de vente harmonisée doit être indiqué séparément.

Delivery required - Livraison exigée	Delivery offered - Livraison proposée
Vendor Name and Address - Raison sociale et adresse du fournisseur	
Name and title of person authorized to sign on behalf of vendor (type or print) - Nom et titre de la personne autorisée à signer au nom du fournisseur (caractère d'imprimerie)	
Name/Nom _____	Title/Titre _____
Signature _____	Date _____

TABLE OF CONTENTS

PART 1 - GENERAL INFORMATION	4
1.1 SECURITY REQUIREMENTS	4
1.2 STATEMENT OF WORK.....	4
1.3 DEBRIEFINGS	4
1.4 TRADE AGREEMENTS	4
PART 2 - BIDDER INSTRUCTIONS	4
2.1 STANDARD INSTRUCTIONS, CLAUSES AND CONDITIONS.....	4
2.2 ELECTRONIC SUBMISSION OF BIDS.....	5
2.3 ENQUIRIES - BID SOLICITATION.....	5
2.4 APPLICABLE LAWS.....	5
PART 3 - BID PREPARATION INSTRUCTIONS	5
3.1 BID PREPARATION INSTRUCTIONS	5
PART 4 - EVALUATION PROCEDURES AND BASIS OF SELECTION	7
4.1 EVALUATION PROCEDURES.....	7
4.2 BASIS OF SELECTION.....	7
PART 5 – CERTIFICATIONS AND ADDITIONAL INFORMATION	7
5.1 CERTIFICATIONS REQUIRED WITH THE BID	7
5.2 CERTIFICATIONS PRECEDENT TO CONTRACT AWARD AND ADDITIONAL INFORMATION	8
PART 6 - RESULTING CONTRACT CLAUSES	8
6.1 SECURITY REQUIREMENTS	8
6.2 STATEMENT OF WORK.....	8
6.3 STANDARD CLAUSES AND CONDITIONS.....	8
6.4 TERM OF CONTRACT	9
6.5 AUTHORITIES	9
6.6 PAYMENT	10
6.7 INVOICING INSTRUCTIONS	11
6.8 CERTIFICATIONS	11
6.9 APPLICABLE LAWS.....	11
6.10 PRIORITY OF DOCUMENTS	11
6.11 DEFENCE CONTRACT	11
6.12 INSURANCE	11
6.13 QUALITY ASSURANCE.....	11
6.14 SHIPPING INSTRUCTIONS (DEPARTMENT OF NATIONAL DEFENCE) – FOREIGN BASED CONTRACTOR	11
6.15 SHIPPING INSTRUCTIONS (DEPARTMENT OF NATIONAL DEFENCE) – CANADIAN BASED CONTRACTOR	14
ANNEX "A"	16
STATEMENT OF WORK	16
ANNEX "B"	19
AMMUNITION S3 OVERALL SEQUENCE (AD1)	19
ANNEX "C"	23
TEST PLAN (AD2).....	23
ANNEX "D"	45

PRICING SCHEDULE.....	45
ANNEX "E"	46
<i>MANDATORY EVALUATION CRITERIA</i>	46
ANNEX "F"	47
ELECTRONIC PAYMENT INSTRUMENTS.....	47

PART 1 - GENERAL INFORMATION

1.1 Security Requirements

There are no security requirements associated with this requirement.

1.2 Statement of Work

The requirement is detailed in Annex "A", Statement of Work.

1.3 Debriefings

Bidders may request a debriefing on the results of the bid solicitation process. Bidders should make the request to the Contracting Authority within 15 working days from receipt of the results of the bid solicitation process. The debriefing may be in writing, by telephone or in person.

1.4 Trade Agreements

The requirement is subject to the provisions of the World Trade Organization Agreement on Government Procurement (WTO-AGP), the Canada-Chile Free Trade Agreement (CCFTA), the Canadian Free Trade Agreement (CFTA), the Canada-Peru Free Trade Agreement (CPFTA), the Canada-Columbia Free Trade Agreement (CCoIFTA), the Canada-Panama Free Trade Agreement (CPanFTA), the Canada-Honduras Free Trade Agreement (CHFTA), the Canada-Korea Free Trade Agreement (CKFTA) and the Canada-European Union Comprehensive Economic and Trade Agreement (CETA) and the Canada-Ukraine Free Trade Agreement (CUFTA) and the Comprehensive and Progressive Agreement for Trans-Pacific Partnership (CPTPP).

PART 2 - BIDDER INSTRUCTIONS

2.1 Standard Instructions, Clauses and Conditions

All instructions, clauses and conditions identified in the bid solicitation by number, date and title are set out in the Standard Acquisition Clauses and Conditions Manual (<https://buyandsell.gc.ca/policy-and-guidelines/standard-acquisition-clauses-and-conditions-manual>) issued by Public Works and Government Services Canada.

Bidders who submit a bid agree to be bound by the instructions, clauses and conditions of the bid solicitation and accept the clauses and conditions of the resulting contract.

The 2003 (2020-05-28) Standard Instructions – Goods and Services – Competitive Requirements, are incorporated by reference into and form part of the bid solicitation, with the following modifications:

- a) Section 02, Procurement Business Number is deleted in its entirety.
- b) Section 20(2), Further Information is deleted in its entirety.
- c) Subsection 2.d. of Section 05, Submission of Bids, is deleted in its entirety and replaced with the following:

Send its bid only to the address specified in the bid solicitation.

- d) Section 06, Late Bids, Is deleted in its entirety;
- e) The text under Section 07, Delayed Bids, is deleted in its entirety and replaced with the following:

It is the Bidder's responsibility to ensure that the Contracting Authority has received the entire submission. Misrouting or other electronic delivery issues resulting in late submission of bids will not be accepted.

- f) Subsection 1 of Section 08, Transmission by Facsimile or by epost Connect, is deleted in its entirety.

2.2 Electronic Submission of Bids

- a) Bids must be submitted only to the Department of National Defence by the date, time and place indicated on page 1 of the bid solicitation. Bids must be received electronically as noted in subparagraph b).
- b) **Electronic Submissions: Individual e-mails exceeding five (5) megabytes, or that includes other factors such as embedded macros and/or links, may be rejected by the DND e-mail system and/or firewall(s) without notice to the Bidder or Contracting Authority.** Larger bids may be submitted through more than one e-mail. The Contracting Authority will confirm receipt of documents. It is the Bidder's responsibility to ensure that the Contracting Authority has received the entire submission. Bidders should not assume that all documents have been received unless the Contracting Authority confirms receipt of each document. In order to minimize the potential for technical issues, Bidders are requested to allow sufficient time before the closing time and date to confirm receipt. Technical and financial documents received after the closing time and date will not be accepted.

Due to the nature of the bid solicitation, bids transmitted by facsimile will not be accepted.

2.3 Enquiries - Bid Solicitation

All enquiries must be submitted in writing to the Contracting Authority no later than ten (10) calendar days before the bid closing date. Enquiries received after that time may not be answered.

Bidders should reference as accurately as possible the numbered item of the bid solicitation to which the enquiry relates. Care should be taken by Bidders to explain each question in sufficient detail in order to enable Canada to provide an accurate answer. Technical enquiries that are of a proprietary nature must be clearly marked "proprietary" at each relevant item. Items identified as "proprietary" will be treated as such except where Canada determines that the enquiry is not of a proprietary nature. Canada may edit the question(s) or may request that the Bidder do so, so that the proprietary nature of the question(s) is eliminated, and the enquiry can be answered to all Bidders. Enquiries not submitted in a form that can be distributed to all Bidders may not be answered by Canada.

2.4 Applicable Laws

Any resulting contract must be interpreted and governed, and the relations between the parties determined, by the laws in force in Ontario.

Bidders may, at their discretion, substitute the applicable laws of a Canadian province or territory of their choice without affecting the validity of their bid, by deleting the name of the Canadian province or territory specified and inserting the name of the Canadian province or territory of their choice. If no change is made, it acknowledges that the applicable laws specified are acceptable to the Bidders.

PART 3 - BID PREPARATION INSTRUCTIONS

3.1 Bid Preparation Instructions

Canada requests that Bidders provide their bid in separately bound sections as follows:

Section I: Technical Bid (1 soft copies)

Section II: Financial Bid (1 soft copies)

Section III: Certifications (1 soft copies)

Prices must appear in the financial bid only. No prices must be indicated in any other section of the bid.

Canada requests that Bidders follow the format instructions described below in the preparation of their bid:

- (a) use 8.5 x 11 inch (216 mm x 279 mm) format;
- (b) use a numbering system that corresponds to the bid solicitation.

Section I: Technical Bid

In their technical bid, Bidders should explain and demonstrate how they propose to meet the requirements and how they will carry out the Work.

Section II: Financial Bid

Bidders must submit their financial bid as follows:

- 1) Bidders must submit firm prices, Free Carrier at ([Contractor's shipping point](#)) Incoterms 2010, Canadian customs duties and excise tax are excluded, Applicable Taxes excluded. The total amount of Applicable Taxes must be shown separately. Bidders must provide the address of the Contractor's shipping point at which the Requirement as noted in Annex A will be made available.

Bids must be submitted in Canadian dollars.

Section III: Certifications

Bidders must submit the certifications and additional information required under Part 5.

3.1.1 Electronic Payment of Invoices – Bid

If you are willing to accept payment of invoices by Electronic Payment Instruments, complete Annex "F" Electronic Payment Instruments, to identify which ones are accepted.

If Annex "F" Electronic Payment Instruments is not completed, it will be considered as if Electronic Payment Instruments are not being accepted for payment of invoices.

Acceptance of Electronic Payment Instruments will not be considered as an evaluation criterion.

3.1.2 Exchange Rate Fluctuation

SACC Manual clause [C3011T](#) (2013-11-06), Exchange Rate Fluctuation

3.1.3 SACC Manual Clauses

Section III: Certifications

Bidders must submit the certifications and additional information required under Part 5.

PART 4 - EVALUATION PROCEDURES AND BASIS OF SELECTION

4.1 Evaluation Procedures

- (a) Bids will be assessed in accordance with the entire requirement of the bid solicitation including the technical and financial evaluation criteria.
- (b) An evaluation team composed of representatives of Canada will evaluate the bids.

4.1.1 Technical Evaluation

4.1.1.1 Mandatory Technical Criteria

Mandatory Technical Criteria can be reference in Annex "E"

4.1.2 Financial Evaluation

The price of the bid will be evaluated in Canadian dollars, Canadian customs duties and excise taxes excluded, Applicable Taxes excluded.

Canada reserves the right to award the Contract Free Carrier at ([Contractor's shipping point](#)) Incoterms 2010, Canadian customs duties and excise tax are excluded, Applicable Taxes excluded. The total amount of Applicable Taxes must be shown separately. Bidders must provide the address of the Contractor's shipping point at which the Requirement as noted in Annex A will be made available.

4.2 Basis of Selection

A bid must comply with the requirements of the bid solicitation and meet all mandatory technical evaluation criteria to be declared responsive. The responsive bid with the lowest evaluated price on an aggregate basis will be recommended for award of a contract.

PART 5 – CERTIFICATIONS AND ADDITIONAL INFORMATION

Bidders must provide the required certifications and additional information to be awarded a contract.

The certifications provided by Bidders to Canada are subject to verification by Canada at all times. Unless otherwise specified, Canada will declare a bid non-responsive, or will declare a contractor in default if any certification made by the Bidder is found to be untrue whether made knowingly or unknowingly, during the bid evaluation period or during the contract period.

The Contracting Authority will have the right to ask for additional information to verify the Bidder's certifications. Failure to comply and to cooperate with any request or requirement imposed by the Contracting Authority will render the bid non-responsive or constitute a default under the Contract.

5.1 Certifications Required with the Bid

Bidders must submit the following duly completed certifications as part of their bid.

5.1.1 Integrity Provisions - Declaration of Convicted Offences

In accordance with the Integrity Provisions of the Standard Instructions, all bidders must provide with their bid, **if applicable**, the declaration form available on the [Forms for the Integrity Regime](http://www.tpsgc-pwgsc.gc.ca/ci-if/declaration-eng.html) website (<http://www.tpsgc-pwgsc.gc.ca/ci-if/declaration-eng.html>), to be given further consideration in the procurement process.

5.2 Certifications Precedent to Contract Award and Additional Information

The certifications and additional information listed below should be submitted with the bid, but may be submitted afterwards. If any of these required certifications or additional information is not completed and submitted as requested, the Contracting Authority will inform the Bidder of a time frame within which to provide the information. Failure to provide the certifications or the additional information listed below within the time frame provided will render the bid non-responsive.

5.2.1 Integrity Provisions – Required Documentation

In accordance with the [Ineligibility and Suspension Policy](http://www.tpsgc-pwgsc.gc.ca/ci-if/politique-policy-eng.html) (<http://www.tpsgc-pwgsc.gc.ca/ci-if/politique-policy-eng.html>), the Bidder must provide the required documentation, as applicable, to be given further consideration in the procurement process.

5.2.2 Federal Contractors Program for Employment Equity - Bid Certification

By submitting a bid, the Bidder certifies that the Bidder, and any of the Bidder's members if the Bidder is a Joint Venture, is not named on the Federal Contractors Program (FCP) for employment equity "FCP Limited Eligibility to Bid" list available at the bottom of the page of the [Employment and Social Development Canada \(ESDC\) - Labour's](http://www.esdc.gc.ca/en/jobs/workplace/human_rights/employment_equity/federal_contractor_program.page?&_ga=1.229006812.1158694905.1413548969#afed) website (http://www.esdc.gc.ca/en/jobs/workplace/human_rights/employment_equity/federal_contractor_program.page?&_ga=1.229006812.1158694905.1413548969#afed).

Canada will have the right to declare a bid non-responsive if the Bidder, or any member of the Bidder if the Bidder is a Joint Venture, appears on the "FCP Limited Eligibility to Bid" list at the time of contract award.

PART 6 - RESULTING CONTRACT CLAUSES

The following clauses and conditions apply to and form part of any contract resulting from the bid solicitation.

6.1 Security Requirements

There is no security requirement applicable to this Contract.

6.2 Statement of Work

The Contractor must perform the Work in accordance with the Statement of Work in Annex "A".

6.3 Standard Clauses and Conditions

All clauses and conditions identified in the Contract by number, date and title are set out in the [Standard Acquisition Clauses and Conditions Manual](https://buyandsell.gc.ca/policy-and-guidelines/standard-acquisition-clauses-and-conditions-manual) (<https://buyandsell.gc.ca/policy-and-guidelines/standard-acquisition-clauses-and-conditions-manual>) issued by Public Works and Government Services Canada.

6.3.1 General Conditions

2010C (2021-12-02), General Conditions - Services (Medium Complexity) apply to and form part of the Contract, with the following modifications:

a. Definition of Minister is modified as follows:

"Canada", "Crown", "Her Majesty" or "the Government" means Her Majesty the Queen in right of Canada as represented by the Minister of National Defence and any other person duly authorized to act on behalf of that minister or, if applicable, an appropriate minister to whom the Minister of National Defence has delegated his or her powers, duties or functions and any other person duly authorized to act on behalf of that minister.

6.4 Term of Contract

6.4.1 Period of the Contract

The period of the Contract is from Date of Contract to _____ (*to be inserted at contract award*).

6.4.2 Option to Extend the Contract

The Contractor grants to Canada the irrevocable option to acquire the goods, services or both described at the Statement of Work at Para 5.2 under the same conditions and at the prices and/or rates stated in the Contract. The option may only be exercised by the Contracting Authority and will be evidenced, for administrative purposes only, through a contract amendment.

The Contracting Authority may exercise the option at any time before the expiry of the Contract by sending a written notice to the Contractor.

6.4.3 Services

Services will be delivered at the location specified in the Statement of Work, "Annex A"

6.5 Authorities

6.5.1 Contracting Authority

The Contracting Authority for the Contract is:

Name: Sarah Gale
Department of National Defence (DND)
Directorate: DLP 7-2-5-4
Telephone: 613-324-7736
E-mail address: sarah.gale-mouldey@forces.gc.ca

The Contracting Authority is responsible for the management of the Contract and any changes to the Contract must be authorized in writing by the Contracting Authority. The Contractor must not perform work in excess of or outside the scope of the Contract based on verbal or written requests or instructions from anybody other than the Contracting Authority.

6.5.2 Project Authority

To be inserted at contract award

The Project Authority for the Contract is:

The Project Authority is the representative of the department or agency for whom the Work is being carried out under the Contract and is responsible for all matters concerning the technical content of the Work under the Contract. Technical matters may be discussed with the Project Authority, however the Project Authority has no authority to authorize changes to the scope of the Work. Changes to the scope of the Work can only be made through a contract amendment issued by the Contracting Authority.

6.5.3 Contractor's Representative

Name: _____
Title: _____
Vendor: _____

Telephone: _____
E-mail address: _____

6.6 Payment

6.6.1 Basis of Payment

In consideration of the Contractor satisfactorily completing all of its obligations under the Contract, the Contractor will be paid a firm price(s), as specified in Annex D for a cost of \$ _____ (insert the amount at contract award). Customs duties are included and Applicable Taxes are extra.

Canada will not pay the Contractor for any design changes, modifications or interpretations of the Work, unless they have been approved, in writing, by the Contracting Authority before their incorporation into the Work.

6.6.2 Single Payment

SACC Manual clause [H1000C](#) (2008-05-12) Single Payment

6.6.3 SACC Manual Clauses

SACC Manual clause [C2000C](#) (2007-11-30) Taxes - Foreign-based Contractor

SACC Manual clause [C2608C](#) (2020-07-01) Canadian Customs Documentation

SACC Manual clause [C2610C](#) (2007-11-30) Customs Duties - Department of National Defence - Importer

6.6.4 Electronic Payment of Invoices – Contract

The Contractor accepts to be paid using any of the following Electronic Payment Instrument(s):

- a. Direct Deposit (Domestic and International);
- b. Electronic Data Interchange (EDI);
- c. Wire Transfer (International Only);

6.7 Invoicing Instructions

Invoices must be distributed as follows:

- a. The original invoice must be forwarded to the electronic address shown on page 1 of the Contract for certification and payment.

6.8 Certifications

6.8.1 Compliance

Unless specified otherwise, the continuous compliance with the certifications provided by the Contractor in its bid or precedent to contract award, and the ongoing cooperation in providing additional information are conditions of the Contract and failure to comply will constitute the Contractor in default. Certifications are subject to verification by Canada during the entire period of the Contract.

6.9 Applicable Laws

The Contract must be interpreted and governed, and the relations between the parties determined, by the laws in force in Ontario.

6.10 Priority of Documents

If there is a discrepancy between the wording of any documents that appear on the list, the wording of the document that first appears on the list has priority over the wording of any document that subsequently appears on the list.

- (a) the Articles of Agreement;
- (b) the general conditions [2010C](#) (2021-12-02), Services (Medium Complexity)
- (c) Annex A, Statement of Work
- (d) Annex B Test Sequence AD1
- (e) Annex C Test Sequence AD2
- (f) Annex D Pricing Schedule
- (g) the Contractor's bid dated _____

6.11 Defence Contract

SACC Manual clause [A9006C](#) (2012-07-16) Defence Contract

6.12 Insurance

SACC Manual clause [G1005C](#) (2016-01-28) Insurance – No Specific Requirement

6.13 Quality Assurance

SACC Manual clause [D5545C](#) (2019-05-03), ISO 9001:2008 – Quality Management Systems Requirement (Quality Assurance Code C)

6.14 Shipping instructions (Department of National Defence) – Foreign based Contractor

1. Delivery will be FCA Free Carrier at _____ (TBD) Incoterms 2000. The Contractor must load the goods onto the carrier designated by the Department of National Defence (DND). Onward shipment from the delivery point to the consignee will be Canada's responsibility

-
2. Before shipping the goods, the Contractor must contact the following DND Inbound Logistics Coordination Center by facsimile or e-mail, to arrange for shipment, and provide the information detailed at paragraph 3.
- a. Insert the following when the Contractor is located in the United States (U.S.):
Inbound Logistics Coordination Center (ILCC):
Telephone: 1-877-447-7701 (toll free)
Facsimile: 1-877-877-7409 (toll free)
E-mail: ILHQOttawa@forces.gc.ca
OR
- b. Insert the following when the Contractor is located in United Kingdom (UK) and Ireland:
Inbound Logistics United Kingdom (ILUK):
Telephone: 011-44-1895-613023, or 011-44-1895-613024, or
Facsimile: 011-44-1895-613046
E-mail: CFSUEDetUKMovements@forces.gc.ca
In addition, the Contractor must send to ILUK the completed form "Shipping Advice and Export Certificate" by e-mail to: CFSUEDetUKMovements@forces.gc.ca.
The shipment of any items above the value of 600 GBP (pound sterling) being exported from the United Kingdom and Ireland will be cleared by DND using Her Majesty's Customs & Excise (HMCE) New Export Systems (NES). The Contractor must comply with HMCE requirements by registering with HMCE or by having a freight forwarder complete the entry. A printed copy of the NES entry Export Declaration clearly displaying the Declaration Unique Consignment Reference Number must be provided by the Contractor and attached to the consignment. The Contractor must ensure that this procedure is carried out for all stores whether they be initial purchase or repair and overhaul export items. HMCE will authorize Canadian Forces Support Unit (Europe) to ship the goods only if the procedure has been adhered to completely and properly by the Contractor. **Note:** To ensure you receive a reply on any contracting information such as Incoterms etc, always include the e-mail address: ILHQcontract-ILHQcontrat@forces.gc.ca in carbon copy (cc).
OR
- c. Insert the following when the Contractor is located in a country other than Canada, the U.S., the UK and Ireland:
Inbound Logistics Europe Area (ILEA):
Telephone: +49-(0)-2203-908-1807 or 2748 or 5304
Facsimile: +49-(0)-2203-908-2746
Email: ILEA@forces.gc.ca
Note: To ensure you receive a reply on any contracting information such as Incoterms etc, always include the e-mail address: ILHQcontract-ILHQcontrat@forces.gc.ca in carbon copy (cc).
OR
- d. Insert the following for U.S. Foreign Military Sales (FMS):
Inbound Logistics Coordination Center (ILCC):
Telephone: 1-877-447-7701 (toll free)
Facsimile: 1-877-877-7409 (toll free)
Email: ILHQOttawa@forces.gc.ca
Canada is responsible for the carrier selection for shipments of the goods supplied under

this FMS contract. Instructions on how to obtain carrier selection from Canada are contained in U.S. Department of Defense 4000.25-8-M, Military Assistance Program Address Directory, and Canadian Special Instructions Indicator (SII). The Contractor must not ship the goods until the SII has been complied with.

3. The Contractor must provide the following information to the DND Inbound Logistics contact when arranging for shipment:
 - a. the Contract number;
 - b. consignee address (if multiple addresses, items must be packaged and labeled separately with each consignee address);
 - c. description of each item;
 - d. the number of pieces and type of packaging (e.g. carton, crate, drum, skid);
 - e. actual weight and dimensions of each piece type, including gross weight;
 - f. copy of the commercial invoice (in accordance with clause [C2608C](#), section 4, of the [Standard Acquisition Clauses and Conditions Manual](#)) or a copy of the Canada Border Services Agency form CI1 [Canada Customs Invoice](#) (PDF 429KB) - ([Help on File Formats](#));
 - g. [Schedule B](#) codes (for exports) and the Harmonized Tariff Schedule codes (for imports);
 - h. Canada-United States-Mexico Agreement Certification of Origin (in accordance with clause [C2608C](#), section 2) for the U.S. and Mexico only;
 - i. full details of dangerous material, as required for the applicable mode of transportation, signed certificates for dangerous material as required for shipment by the International Maritime Dangerous Goods Code, or International Air Transport Association regulations or the applicable Canadian [Dangerous Goods Shipping Regulations](#) and a copy of the safety data sheet.
4. Following receipt of this information by Canada, Canada will provide the appropriate shipping instructions, which may include the requirement for specific consignee address labelling, the marking of each piece with a Transportation Control Number and customs documentation.
5. The Contractor must not ship goods before receiving shipping instructions from the DND Inbound Logistics contact.
6. If the Contractor delivers the goods at a place and time that are not in accordance with the given delivery instructions or fail to fulfill reasonable delivery instructions given by Canada, the Contractor must reimburse Canada any additional expenses and costs incurred
7. If Canada is responsible for delays in delivering the goods, ownership and risk will be transferred to Canada upon expiry of either 30 days following the date on which a duly completed shipping application is received by Canada or by its appointed forwarding agent, or 30 days following the delivery date specified in the Contract, whichever is later.

6.15 Shipping instructions (Department of National Defence) – Canadian based Contractor

1. Delivery will be FCA Free Carrier at _____ (*Insert the named place, e.g. Contractor's facility*) Incoterms 2000. The Contractor must load the goods onto the carrier designated by the Department of National Defence (DND). Onward shipment from the delivery point to the consignee will be Canada's responsibility.
2. Before shipping the goods, the Contractor must contact the following DND Inbound Logistics Coordination Center by facsimile or e-mail, to arrange for shipment, and provide the information detailed at paragraph 3.
 - a. *Insert the following for all sole source contracts, except repair and overhaul, where the Contractor is located in Canada:*
Inbound Logistics Co-ordination Center (ILCC)
Telephone: 1-877-877-7423 (toll free)
Facsimile: 1-877-877-7409 (toll free)
E-mail: ILHQOttawa@forces.gc.ca
 - b. *Insert the following for all repair and overhaul contracts where the Contractor is located between Kingston inclusive and westward to the Ontario/Manitoba border:*
Inbound Logistics Central Area (ILCA)
Telephone: 1-866-371-5420 (toll free)
Facsimile: 1-866-419-1627 (toll free)
E-mail: ILCA@forces.gc.ca
 - c. *Insert the following for all repair and overhaul contracts where the Contractor is located in Manitoba, Saskatchewan, Alberta, British Columbia, and the National Capital Region inclusive to east of Kingston:*
Inbound Logistics Coordination Center (ILCC)
Telephone: 1-877-877-7423 (toll free)
Facsimile: 1-877-877-7409 (toll free)
E-mail: ILHQOttawa@forces.gc.ca
 - d. *Insert the following for all repair and overhaul contracts where the Contractor is located in Quebec:*
Inbound Logistics Quebec Area (ILQA)
Telephone: 1-866-935-8673 (toll free), or
1-514-252-2777, ext. 4673, 2852
Facsimile: 1-866-939-8673 (toll free), or
1-514-252-2911
E-mail: 25DAFCTrafficQM@forces.gc.ca

-
- e. Insert the following for all repair and overhaul contracts where the Contractor is located in Atlantic (New Brunswick, Prince Edward Island, Nova Scotia, Newfoundland and Labrador):
- Inbound Logistics Atlantic Area (ILAA)
Telephone: 1-902-427-1438
Facsimile: 1-902-427-6237
E-mail: BlogILAA@forces.gc.ca
3. The Contractor must provide the following information to the DND Inbound Logistics Coordination Center when arranging for shipment:
- a. the Contract number;
 - b. consignee address (for multiple addresses, items must be packaged and labelled separately with each consignee address);
 - c. description of each item;
 - d. the number of pieces and type of packaging (i.e., carton, crate, drum, skid);
 - e. actual weight and dimensions of each piece type, including gross weight;
 - f. full details of dangerous goods/hazardous products, as required for the applicable mode of transportation, signed certificates for dangerous goods/hazardous products as required for shipment by the International Maritime Dangerous Goods Code, the International Air Transport Association regulations or the applicable Canadian [Transportation of Dangerous Goods Regulations](#), and a copy of the safety data sheet in English and French.
4. Following receipt of this information by Canada, Canada will provide the appropriate shipping instructions, which may include the requirement for specific consignee address labelling, and the marking of each piece with a Transportation Control Number.
5. The Contractor must not ship the goods before receiving shipping instructions from the DND Inbound Logistics contact.
6. If the Contractor delivers the goods at a place and time which are not in accordance with the given delivery instructions or fail to fulfill reasonable delivery instructions given by Canada, the Contractor must reimburse Canada any additional expenses and costs incurred.
7. If Canada is responsible for delays in delivering the goods, ownership and risk will be transferred to Canada upon expiry of either 30 days following the date on which a duly completed shipping application is received by Canada or by its appointed forwarding agent, or 30 days following the delivery date specified in the Contract, whichever is later.

ANNEX "A"

STATEMENT OF WORK

1. TITLE

Vibration Ammunitions

2. BACKGROUND

The Quality Engineering Test Establishment (QETE)/ Munitions Experimental Test Centre (METC) is currently performing a Safety and Suitability for Service (S3) assessment for the Sniper System Project. Due to unexpected circumstances, a part of the test has to be outsourced in order to finish the assessment in time for the commissioning of this ammunition. A sequence of the test has to be performed by the contractor on ammunition boxes and ammunition as well.

3. ACRONYMS

AD	Applicable Documents
GFE	Government Furnished Equipment
QETE	Quality Engineering Test Establishment
METC	Munitions Experimental Test Centre
NSN	Nato Stock Number
S3	Safety and Suitability for Service
SOW	Statement of Work
TA	Technical Authority

4. APPLICABLE DOCUMENTS & REFERENCES

AD1: 1819-015A S3 Overall Private Sequence.pdf

AD1.1: MIL-STD-810H (http://everyspec.com/mil-std/mil-std-0800-0899/mil-std-810h_55998/)

AD2: 1819-015A S3 Overall Private Test Plan.pdf

5. TASKS

5.1. Life cycle testing

5.1.1. The contractor must perform the sequence of tests as described in AD1 and AD2.

5.1.2. The contractor must include a timetable for the work, including tests performed per week and all sequences in which the work must be completed in order to track progress of all tests.

5.1.3. The contractor must send a weekly update to the technical authority which includes test completion, confirmation of test success, vibration profile obtained, results of inspection, major roadblocks and planned schedule for the following weeks.

5.1.4. The contractor must produce a report which includes:

5.1.4.1. The nature of the item under test.

- 5.1.4.2. A matrix which details the start/end date and time for each test and ammunition box.
- 5.1.4.3. Description and photos showing setup and how each test was performed.
- 5.1.4.4. Notes and photographic evidence that describes every defect that was noted during the test sequence as described in AD1.
- 5.1.4.5. The vibration output measured by the accelerometer to ensure vibrations were within the specs of the test plans. Charts of this data must be in the report and the raw data transferred to the technical authority.
- 5.1.4.6. Impact angles for the drop test.
- 5.1.4.7. The recorded temperature profile of the conditioning chambers for each pre-conditioning and each test.

5.2. Additional Testing (Options)

Canada requires three optional years for additional testing. The optional testing must repeat the sequence as described in section 5.1 with other ammunition boxes or perform equivalent tests in length and severity with other ammunition boxes.

6. Deliverables

6.1. Deliverables for task 5.1:

- 6.1.1. All ammunition, ammunition boxes, equipment and parts provided sent for the tests, must be handed to METC's ammo tech at the end of the test as described in AD1.
- 6.1.2. A weekly update must be sent to the technical authority by email.
- 6.1.3. A draft report shall be sent in regards with any anomalies prior to the submission of the final report. The contractor must deliver the report to METC.
- 6.1.4. The raw data must be transferred to the technical authority either by cloud storage or other method at the discretion of the contractor upon approval by the technical authority.
- 6.1.5. Sequence of tests must be completed and all provided ammunition, ammunition boxes, equipment and parts must be sent back to METC maximum 8 weeks after the reception of the GFE as described in section 13.
- 6.1.6. Weekly update must be sent to technical authority no later than Friday of each week from the moment the contractor receives the ammunition, ammunition boxes, equipment and parts to the moment all of the provided ammunition, ammunition boxes, equipment and parts are sent back.
- 6.1.7. Report must be delivered to METC within 4 weeks of completion of the test.
- 6.1.8. Raw data must be transferred to the technical authority within 4 weeks of completion of the test.

6.2. Deliverables for options 1, 2 and 3:

Deliverables for option years 1, 2 and 3 are the same as outlined at section 6.1 of this SOW, "Deliverables for task 5.1"

7. Language of Work

The documentation produced by the contractor and the exchanges with the latter must be in French or English.

8. Location of Work

The work must be performed on the Contractor's site.

9. Travel

The contractor is not required to travel.

10. MEETINGS

- 10.1. The contractor must host visits by the client at the sole discretion of the client.
- 10.2. A kick off meeting must be held between the contract and the technical authority within 5 working days of contract award.
- 10.3. The contractor must be able to meet via video conference in the test area to discuss test results.

11. GOVERNMENT SUPPLIED MATERIAL (GSM)

None

12. GOVERNMENT FURNISHED EQUIPMENT (GFE)

GFE 1: Ctg .308 Win C181

Quantity: 8 boxes (400 Cartridges per boxes = 3200 Cartridges)

Ammunition NSN: 1305-20-004-2484

M2A1 Ammunition Box NSN: 8140-00-960-1699

Lot Number: IVI18C09-01 / IVI17L08-01

GFE 2: Ctg .308 Win C181 (Out of test boxes)

Quantity: 4 boxes (400 Cartridges per boxes = 3200 Cartridges)

Ammunition NSN: 1305-20-004-2484

M2A1 Ammunition Box NSN: 8140-00-960-1699

Lot Number: IVI18C09-01 / IVI17L08-01

GFE 3: Plywood and brackets to hold ammunition boxes in place on shaker system (If requested by contractor).

13. SPECIAL CONSIDERATIONS

Ammunition is not a controlled good under the Defense Production Act, which lists controlled goods. Section 6.e.2 states that any ammunition with a calibre smaller than or equal to 12.7mm is not considered to be controlled goods.

ANNEX "B"

AMMUNITION S3 OVERALL SEQUENCE (AD1)

Ammunition S3 Overall Sequence

1. Test general information

8 boxes of ammunition are to be tested in accordance with the attached test plan. Those tests are to be done in a specific sequence in order to simulate the appropriate life cycle.

The test is **Unclassified**.

2. Unit under test

Ammunition	8x Boxes Ctg .308 Win C181 Lot: IVI18C09-01 / IVI17L08-01 400 rounds per boxes -> 3200 rounds AMMO BOX: 51, 52, 53, 54 (cold branch), 55, 56, 57, 58 (hot branch)
-------------------	--

3. Overview Methodology

- 3.1. Upon reception of the ammunition boxes, the contractor must let METC know it has the ammunition by signing a DND 2287.
- 3.2. The ammunition must be kept in a locked area outside of operating hours. The locked area can be a conditioning chamber if it provides appropriate protection. The keys must be handed to a restricted list of persons.
- 3.3. Conditioning must be performed for a minimum of 24 hours before starting the hot and cold sequence to ensure the test items are completely soaked.
- 3.4. Once the test items are soaked, they must remain conditioned for the duration of the test. Otherwise, the conditioning must be restarted as in 3.3.
- 3.5. It is acceptable to transfer test item from a conditioning chamber to another one for operations like axis changes on the shaker. In these conditions, a minimum 1 hour reconditioning is acceptable to ensure the test item temperature is stable at its prescribed temperature.
- 3.6. Temperature of the conditioning chamber/environmental chamber must be recorded for the report.
- 3.7. For each vibration, an accelerometer must be used to confirm that the vibration output was in accordance with the test plan. The output must be recorded in Continuous Time Domain and frequency domain.
- 3.8. Testing on ammunition must be performed following sequence as seen in section 4.
- 3.9. A visual inspection must be performed on tested items upon reception and after each test in accordance with section 5. Record those notes for the report.
- 3.10. Verification performed by METC's ammo tech must be performed after each test/orientation before proceeding with subsequent tests. This verification will either be performed on site or on a video call. An hour of reconditioning must be observed each time as in 3.5.
- 3.11. Test results must be delivered to the technical authority before proceeding with subsequent tests in order to ensure test items were tested adequately
- 3.12. Once the whole sequence is completed, ammunition boxes and furnished equipment (if any) must be handed to METC's ammo tech on site who will package the ammunition to ship it back to METC.

4. Sequence

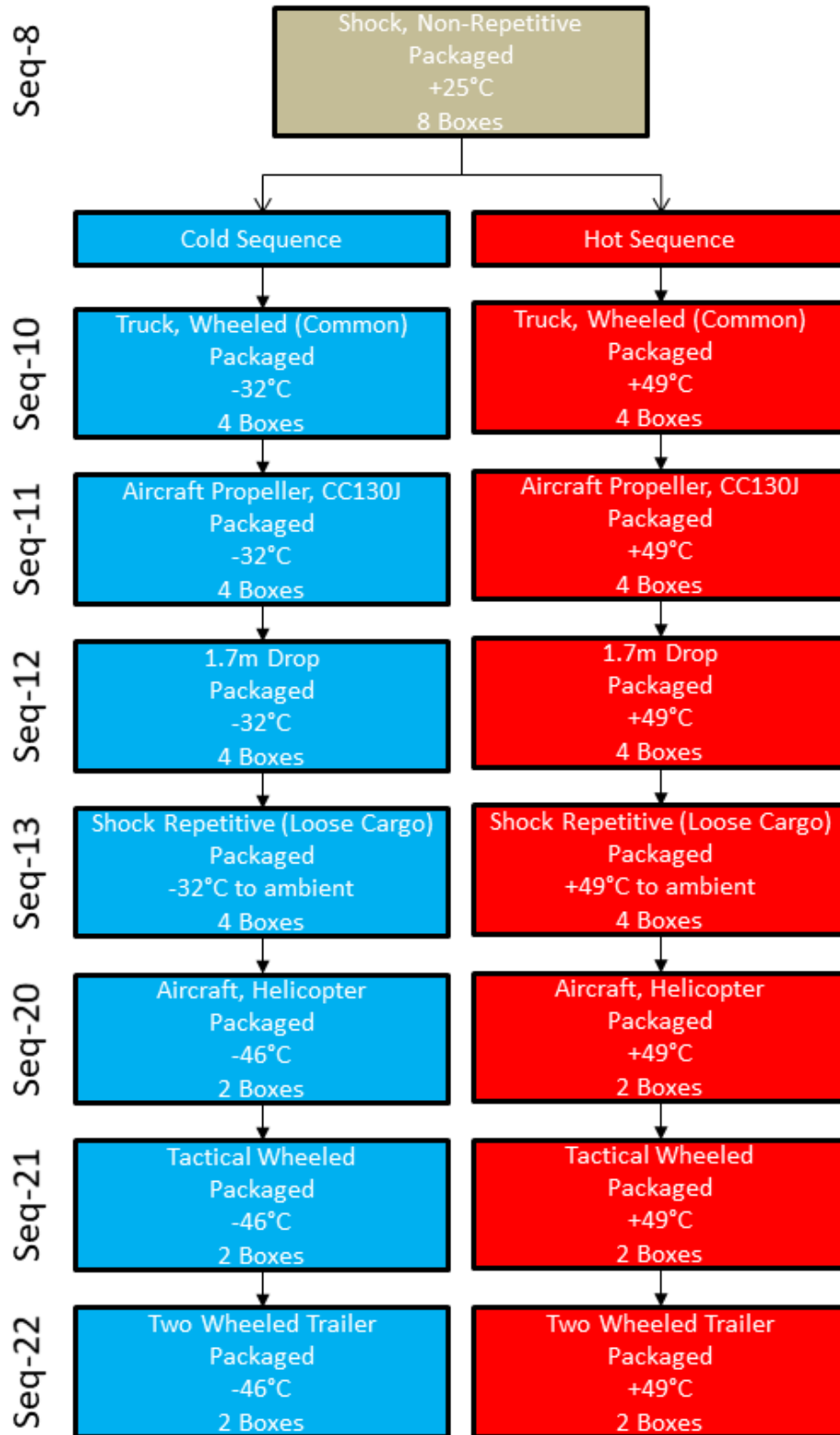

5. Visual Inspection

Upon reception and after each test, ammunition boxes must be visually inspected in accordance with the points below.

5.1. M2A1 Ammunition Boxes

- 5.1.1. Look at the exterior of the ammunition boxes for any signs of damage (scratches, cracks, crushed corner, defective handle, defective hinge, etc.).
- 5.1.2. Notes and photograph any defect.
- 5.1.3. Identify these defects by box#, sequence and branch (example: Box 2 Cold Seq-22)

5.2. Cardboard Boxes

- 5.2.1. Open the ammunition boxes and look at the packaging for any signs of damage (scratches, punctured holes, teared boxes, etc.).
- 5.2.2. Look at both layers of in corner and in the centre of the ammunition box.
- 5.2.3. Take pictures of the ammunition box, including inside wall/flaps if signs of wear appear, cardboard boxes and ammunition itself before and after each test/orientation.
- 5.2.4. Notes and photograph any defect.
- 5.2.5. Identify these defects by box#/cardboard box#, sequence and branch (example: 2/12 Cold Seq-22)
- 5.2.6. Final design of packaging still in development might be different than Figure 1.



Figure 1 : Left Ammunition Box M2A1. Right: Cardboard boxes inside the M2A1 Ammunition Box.

6. Vibration Tolerance and Control Strategy

6.1. Each vibration performed (Seq 10, 11, 20, 21 and 22) must follow the tolerances described in MIL-STD-810H (AD1.1), Method 514.8, section 4.2.2 and table below as reference.

Parameter	Tolerance	
Number (n) of independent statistical degrees of freedom (DOF) for control of the specified ASD.	n>120	
Composite Control: Maximum deviation of the composite control ASD in relation to the specified ASD.	± 3 dB below 500 Hz ± 6 dB above 500 Hz ±10% overall grms	
Multi-Point Control: Maximum deviation of any individual control channel ASD in relation to the specified ASD.	Average Control: ± 6 dB below 500 Hz ± 9 dB above 500 Hz ± 25% overall grms	Extremal Control - 6 dB / +3 dB below 500 Hz - 9 dB / +6 dB below 500 Hz ± 25% overall grms
Cross-axis Motion: ASD measured with the same number of DOF as in the test axis, along the mutually orthogonal directions, in relation to the in-axis specified ASD.	Less than 50% below 500 Hz Less than 100% above 500 Hz Less than the relevant specified ASD for the given cross-axis	
Frequency sweep rate	± 10% of stated rate	
Test time duration	± 5% of stated duration	
Amplitude distribution of the instantaneous values of the random vibration measured at the drive signal.	Nominally Gaussian	

6.2. A minimum of two accelerometers must be installed on the shaker table to control the vibration. A Multi-Point Average control strategy must be used.

ANNEX "C"

Test plan (AD2)

Ammunition S3

Sequential Phase 8 – Shock, Non-Repetitive

8-1 - Test general information

Made IAW **AECTP 400, Method 403**
AMMO BOX: 51, 52, 53, 54, 55, 56, 57, 58

8-2 – Material

Ammunition	<ul style="list-style-type: none"> ➤ 8 C181 Boxes of Testing Lot: IVI18C09-01 / IVI17L08-01 as seen above ➤ 4 C181 Boxes "out of test"
Conditioning	Shaker

8-3 – Methodology

- Test is done at ambient temperature (25°C ±10).
- Preliminary shock must be performed using Out of test Boxes to ensure the shock is adequate.
- Then, each tested ammo box must be shocked in all three axis positive and negative direction (6 shock total/boxes).
- Shock is performed using the classical shock half-sin waveform with 11ms duration and peak amplitude of 8.0 Gs.
- Tolerance on the shock is as seen in figure below.

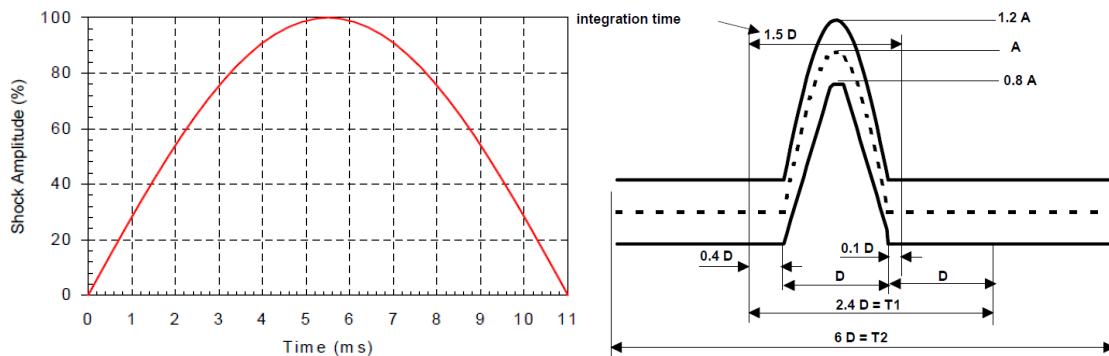

- Use the following orientations for the vibration.

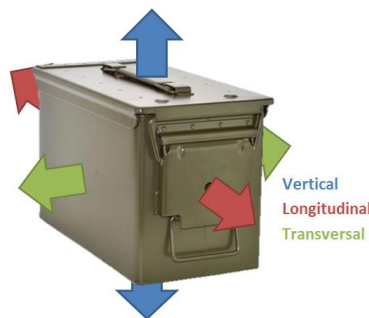

Ammunition S3
Sequential Phase 10 – Ground Wheeled Common Carrier

10-1 - Test general information

Made IAW **AECTP 400, Method 401**

AMMO BOX: 51, 52, 53, 54 (cold branch), 55, 56, 57, 58 (hot branch)

10-2 – Material

Ammunition	8 C181 Boxes of Testing Lot IVI18C09-01 / IVI17L08-01
Conditioning	Vibration & Conditioning unit

10-3 – Methodology

- Test is done at **-32°C ±2** for boxes 1, 2, 3, 4 and at **+49°C ±2** for boxes 5, 6, 7, 8.
- Random vibration performed IAW the specification given in section 10-4 below.
- Take pictures of the ammunition box, including inside wall/flaps if signs of wear appear, cardboard boxes and ammunition itself before and after each test/orientation.
- Use the following orientations for the vibration.



10-4 – Ground Wheeled Common Carrier Vibration Pattern.

Test Axis: Vertical, Transverse, and Longitudinal
Test Duration: Vertical axis, **75 min.**
Transverse and Longitudinal Axis, **3 hours / axis**
Equivalence Factor: Vertical, 60 minutes / axis represents 4000 km.
Trans. / Long., 60 minutes / axis represents 1609 km.
Vibration Spectrum: **Broadband (500 Hz) random vibration**
Control Strategy: Multi-point control (Average)
1. Use the maximum control system roll-off rate at the 5 and 500 Hz breakpoints.
2. The test schedules are derived for a control accelerometer(s) located at the material and transportation platform interface.

Schedule Description

The Figure A-1 test schedules depict the test severity at the cargo bed of a composite of wheeled common carrier vehicles. Transportation of secured cargo on the bed area of a truck during cross-country highway transportation is the typical environment. The vertical axis is up from the ground (truck cargo bed), transverse is perpendicular across the roadway, and longitudinal is parallel to the roadway. These curves are based upon data measured at the cargo bed of different configurations of single and multiple axle trucks and tractor-trailer combinations. Both conventional leaf-spring suspensions and air-cushioned suspensions are represented. The data were collected from typical highways with rough highway sections as part of the database. The vehicle data also includes variation in vibration amplitude levels due to the truck load capacity percentage. The test schedules are a worst case envelope of the measured data. An exaggeration factor has been applied to the measured data to increase the ASD amplitude and decrease the laboratory simulation test duration. In general, as illustrated in the figure, the vertical axis vibration is highest at low frequencies due to sprung and unsprung mass vibration. The longitudinal and transverse are respectively lower amplitude, in the low frequency band and higher amplitude at higher frequency where structural frame member resonance and harmonics occur. The specific cargo area with the most severe vibration is a function of several factors. Figure A-1 is developed from the Def Stan 0035 and MIL-STD 810.

Common Carrier Schedule Breakpoints					
Vertical		Transverse		Longitudinal	
Hz	G ² /Hz	Hz	G ² /Hz	Hz	G ² /Hz
5	0.015	5	0.00013	5	0.00650
50	0.015	10	0.00013	20	0.00650
500	0.001	20	0.00065	120	0.00020
		30	0.00065	121	0.00300
		78	0.00002	200	0.00300
		79	0.00019	240	0.00150
		120	0.00019	340	0.00003
		500	0.00001	500	0.00015
Grms = 1.45		Grms = 0.21		Grms = 0.76	

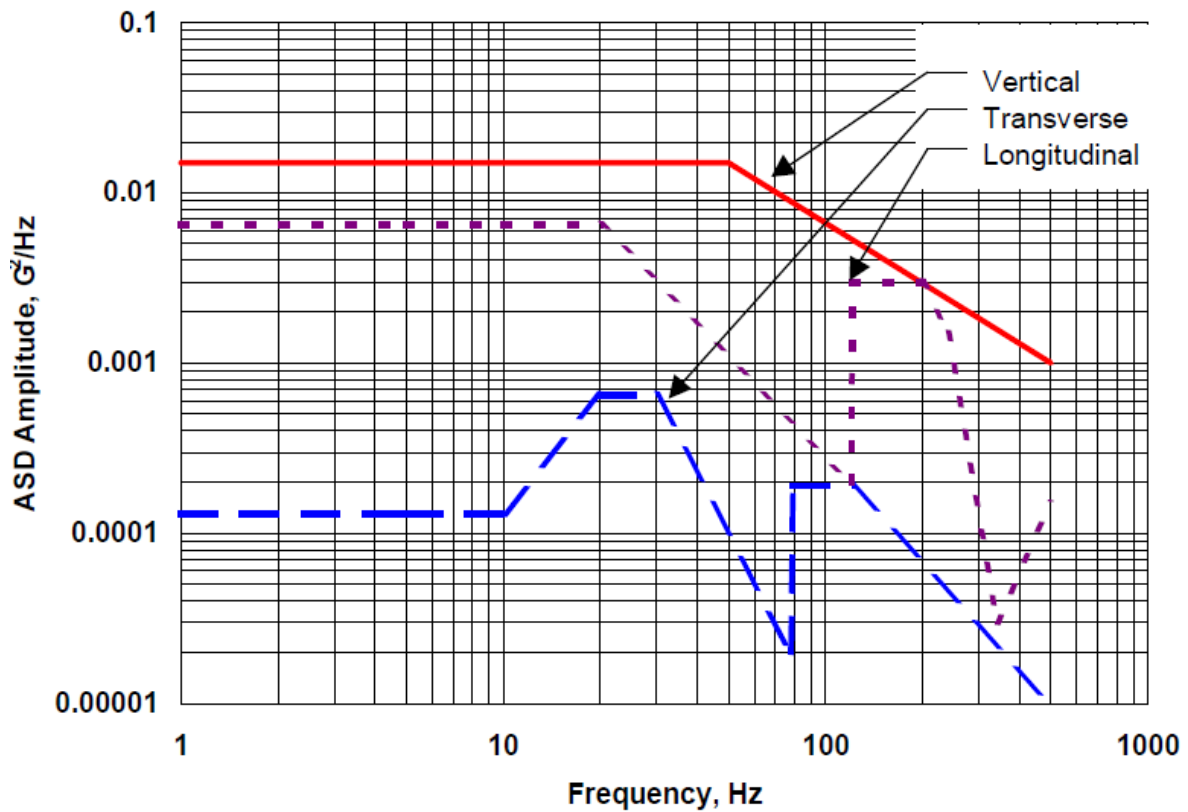

Figure A-1 : Ground Wheeled Common Carrier

Ammunition S3
Sequential Phase 11 – CC130J Aircraft Propeller Vibration

11-1 - Test general information

Made IAW **AECTP 400, Method 401**

AMMO BOX: 51, 52, 53, 54 (cold branch), 55, 56, 57, 58 (hot branch)

11-2 – Material

Ammunition	8 C181 Boxes of Testing Lot IVI18C09-01 / IVI17L08-01 as seen above
Conditioning	Vibration & Conditioning unit

11-3 – Methodology

- Test is done at **-32°C ±2** for boxes 1, 2, 3, 4 and at **+49°C ±2** for boxes 5, 6, 7, 8.
- Random vibration performed IAW the specification given in section 11-4 below.
- Take pictures of the ammunition box, including inside wall/flaps if signs of wear appear, cardboard boxes and ammunition itself before and after each test/orientation.
- Use the following orientations for the vibration.



11-4 – CC130J Aircraft Propeller Vibration Pattern.

Test Axis: Vertical, Transverse, and Longitudinal
Test Duration: **1 hours / axis**
Equivalence Factor: None
Vibration Spectrum: **Narrowband random on broadband random vibration (NBROR)**
Control Strategy: Multi-point control (Average)

1. Use the maximum control system roll-off rate at the 12 and 2000 Hz breakpoints.
2. The test schedules are derived for a control accelerometer(s) located at the material and transportation platform interface.

Schedule Description

The Figure C-1 test schedule depicts the test severity for material installed in, or secured cargo located on, fixed wing propeller aircraft during normal flight operations. The figure provided is a general representation of the vibration environment due to structural and acoustic excitation from the engine, propeller, and the aerodynamic flow over the external aircraft. The location specific fundamental, propeller blade passage frequency, and harmonic narrowband amplitudes and frequencies are determined from the accompanying table. The test schedule is an envelope applicable for all three test axes (vertical, transverse, longitudinal) and was derived from vibration measurements on various C-130 and P-3 aircraft. The vibration spectrum presented is applicable for both a constant and variable propeller speed; however, tailoring of the narrowband amplitude, bandwidth, and sweep bandwidth based on measured data is desirable for variable speed propellers. The use of several NBROR spectrum, or swept bandwidths, to represent multiple engine operating conditions or speeds may be necessary. Typically the narrowband amplitude and swept bandwidth will be a function of the engine power output and the associated engine RPM for each operating condition such as take-off, maximum power, cruise, and engine idle. Figure C-1 is not representative of severe vibration due to aircraft combat maneuvers. The narrowband amplitudes provided may not be applicable for all locations on C-130J aircraft; some C-130J aircraft locations have narrowband harmonic amplitudes that are approximately flat; the harmonics do not roll off at 6 dB/Octave. Use measured C130J aircraft data for this requirement. Figure C-1 may not be applicable for all material carried as secured cargo on the floor of the aircraft. The vibration spectrum for this environment is similar to that presented; however measurement of flight data is suggested to tailor the low frequency response and package to airframe coupling characteristics. Figure C-1 is developed from MIL-STD 810

Test Parameters	
F ₀	68 Hz
F ₁	136 Hz
F ₂	204 Hz
F ₃	272 Hz
L ₀	0.3 g ² /Hz

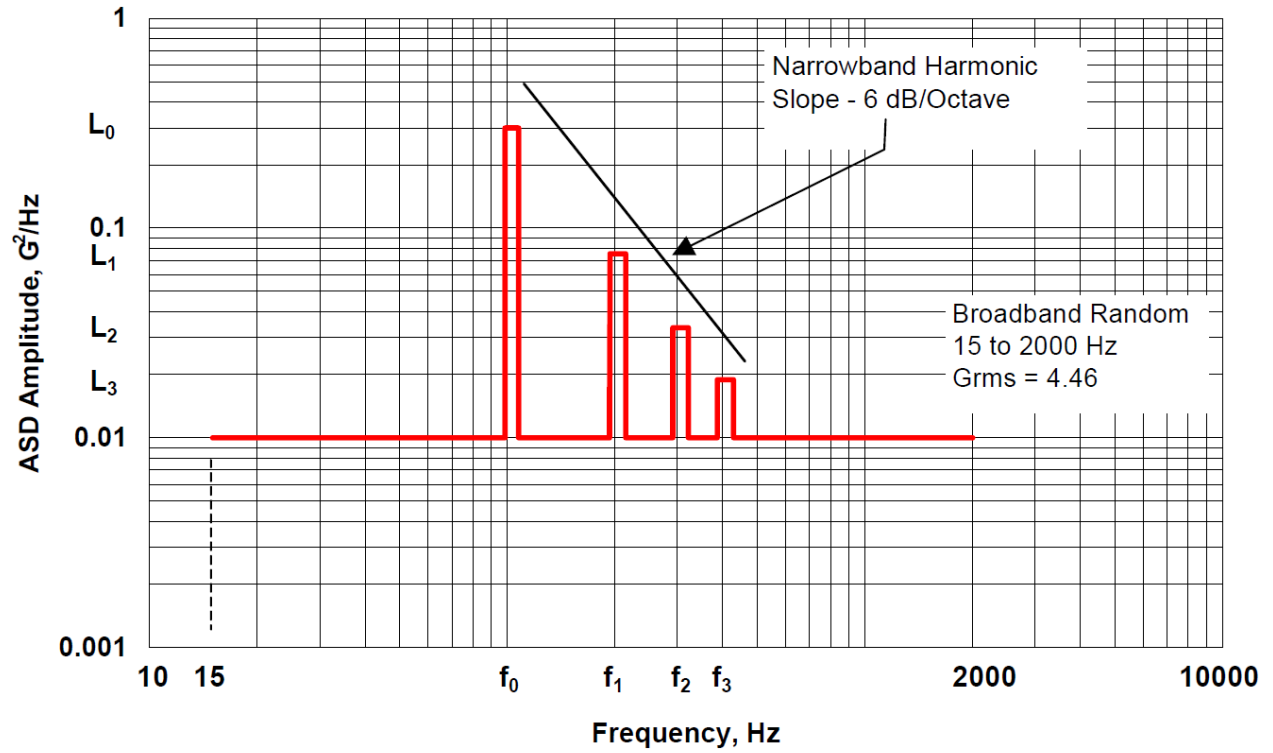

Figure C-1: Propeller Aircraft

Ammunition S3
Sequential Phase 12 – 1.7m Drop

12-1 – Test general information

Made IAW **AECTP 400, Method 414**

AMMO BOX: 51, 52, 53, 54 (cold branch), 55, 56, 57, 58 (hot branch)

12-2 – Material

Ammunition	➤ 8 C181 Boxes of Testing Lot IVI18C09-01 / IVI17L08-01 as seen above
Conditioning	Drop Facility must include: <ul style="list-style-type: none">➤ An instantaneous release device.➤ Impact Surface must be a 50mm (2in.) thick Plywood backed by 100mm (minimum) thick concrete.➤ Impact surface must be within 2 degrees of being horizontal.➤ A plywood arena as seen in section 12-6 around the drop region to protect nearby equipment and gather ammunition in case of spreading.
Imagery	<ul style="list-style-type: none">➤ A camera + background must be set up to ensure that the drop height is adequate as seen in section 12-5.➤ 2 Orthogonal Cameras to confirm the orientation of the test item at impact as seen in section 12-6.

12-3 – Methodology

- The Ammo box must be dropped from a 1.7m height \pm 0.05m.
- The test item shall be oriented so that upon impact a line from the centre of gravity of the test item to the point of impact is perpendicular to the impact surface.
- Use the 2 orthogonal cameras to compute the impact angle of the box. Record this information for the report.
- 2 Drops per box must be performed as seen in section 12-4.
- Ensure that the ammunition box is back to its prescribed temperature before the second drop.
- The drop test should be performed within the shortest duration possible upon removal from the conditioned environment. Max duration: 5 minutes.
- Use thermal mitigation measures (i.e. insulated transport box or insulating blanket) to minimize heat transfer.
- Take pictures of the ammunition box, including inside wall/flaps if signs of wear appear, cardboard boxes and ammunition itself before and after each test/orientation.

12-4 – Serial Matrix

Serial #	Box #	Box Orientation	Projectiles Orientation*
1	1	A – Bottom Face	Downwards
2	2	B – Top Face	Up
3	3	C – End side	Sideways
4	4	D – Front Face	Sideways
5	1	E – Top Corner	Askew upwards
6	2	F – Bottom Corner	Askew downwards
7	3	G – Top Long edge	Askew upwards
8	4	H – Bottom Short edge	Askew downwards
9	5	A – Bottom Face	Downwards
10	6	B – Top Face	Up
11	7	C – End side	Sideways
12	8	D – Front Face	Sideways
13	5	E – Top Corner	Askew upwards
14	6	F – Bottom Corner	Askew downwards
15	7	G – Top Long edge	Askew upwards
16	8	H – Bottom Short edge	Askew downwards

*List above assumes projectile pointing downward.

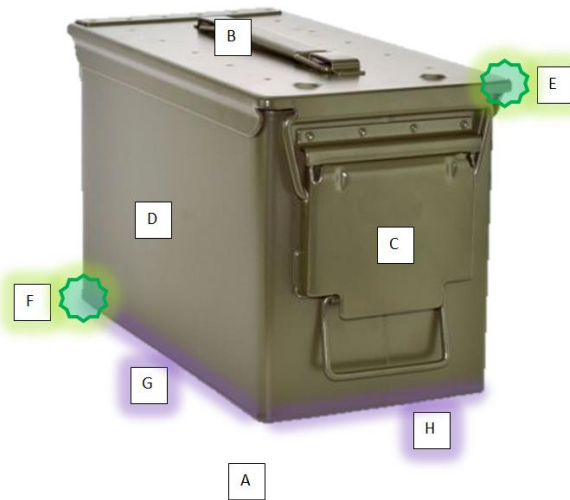

12-5 – Imagery setup example



12-6 – Drop Arena to contain ammunition

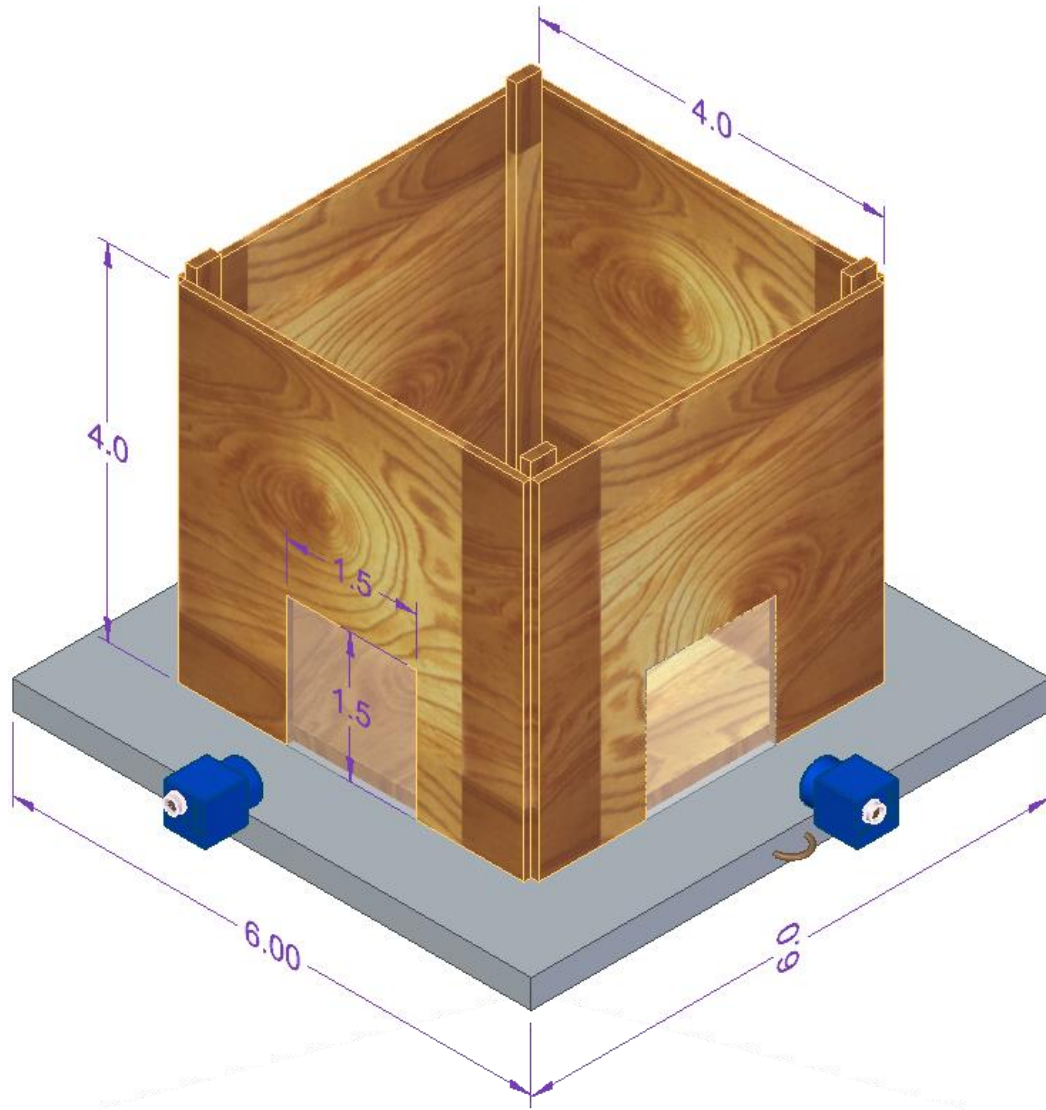

Ammunition S3

Sequential Phase 13 – Shock repetitive, Loose Cargo

13-1 – Test general information

Made IAW **AECTP 400, Method 406**

AMMO BOX: 51, 52, 53, 54 (cold branch), 55, 56, 57, 58 (hot branch)

13-2 – Material

Ammunition	➤ 8 C181 Boxes of Testing Lot: IVI18C09-01 / IVI17L08-01 as seen above
Conditioning	Loose Cargo system IAW section 13-4

13-3 – Methodology

- Test is started at **-32°C ±2** for boxes **1, 2, 3, 4** and at **+49°C ±2** for boxes **5, 6, 7, 8**.
- Allow boxes' temperature to return to ambient as test progress.
- System must produce a 1 in. peak to peak circular synchronous motion at 5 Hz (300 RPM) for **20 minutes**.
- **Tolerance of the speed of rotation** is ± 2 RPM.
- After 10 minutes, turn the ammunition box on its side and continue for the other 10 minutes.
- Take pictures of the ammunition box, including inside wall/flaps if signs of wear appear, cardboard boxes and ammunition itself before and after each test/orientation.

13-4 – Typical Package tester

- The fence opposite the vertical impact wall is not intended as an impact surface, but is used to restrain the test item from leaving the tester. The distance to this restraining fence should be sufficient to prevent constant impact, but still prevent one or more of multiple test items from "walking" away from the others.
- The height of the test enclosure (sideboards, impact wall and restraining fence) should be at least 5 cm higher than the height of the test item to prevent unrealistic impacting of the test item on the top of the enclosure.
- The test bed of the test system shall be covered with a cold-rolled steel plate, 5 to 10 mm thick. The metal plate shall be secured with bolts, with the tops of the heads slightly below the surface. The bolts shall be at sufficient intervals around the four edges and through the centre area to prevent diaphragming of the steel plate.
- The dimensions of the test area must prevent unlimited rotation about vertical axis.
- The default space around the perimeter of a test item or an item and a barrier wall is a minimum of one inch (25.4 cm) at the start of testing. Size of the test area must be adjusted once ammo box are flipped on their side to respect this space around the test items.
- The ammunition boxes are to be on their base with their longest dimension parallel to the place of rotation of the bed.
- Test area must be large enough to test 4 boxes altogether.

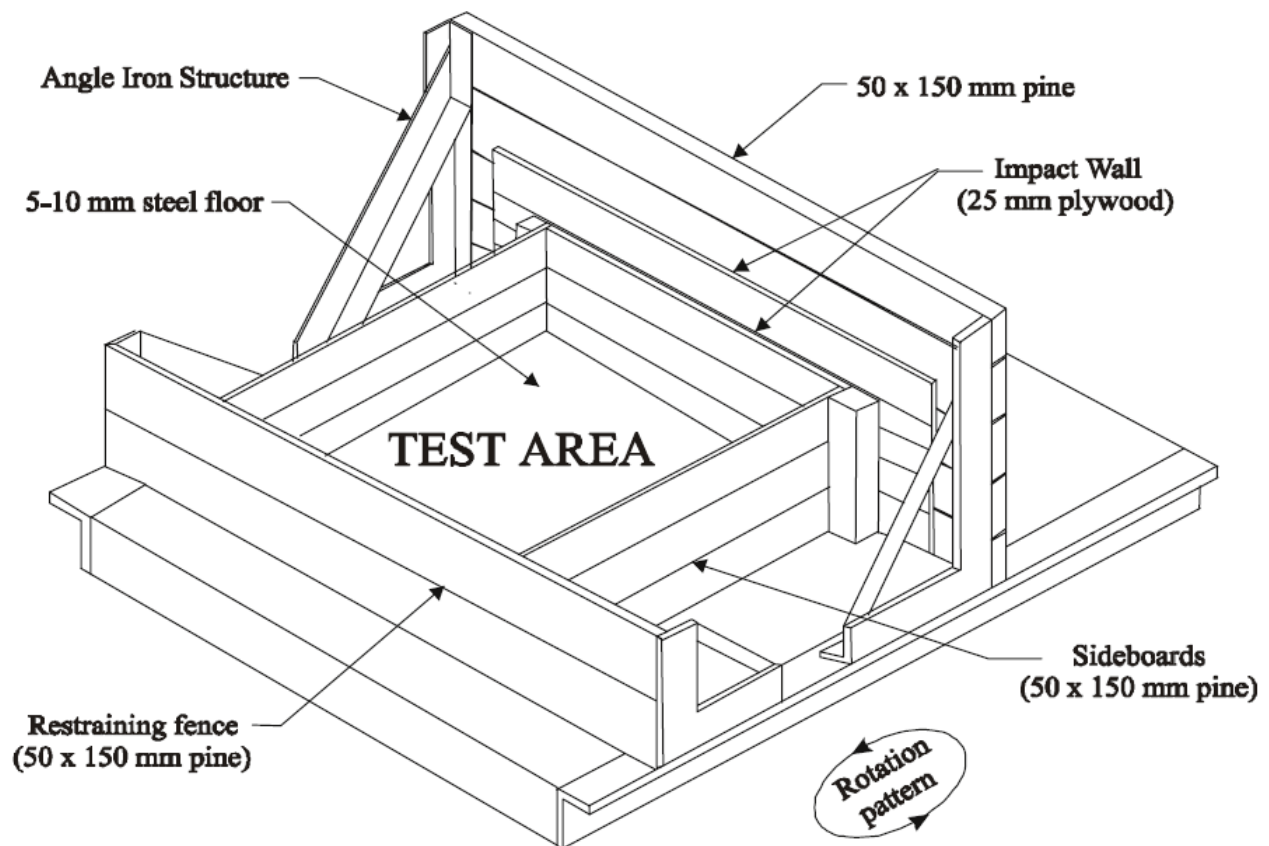

Ammunition S3
Sequential Phase 20 – CH-146 Griffon Helicopter Vibration

20-1 – Test general information

Made IAW **AECTP 400, Method 401**

AMMO BOX: 51, 52 (cold branch), 55, 56 (hot branch)

20-2 – Material

Ammunition	C181 Boxes of Testing Lot: IVI18C09-01 / IVI17L08-01 as seen above
Conditioning	Vibration & Conditioning unit

20-3 – Methodology

- Test is done at **-46°C ±2 for boxes 1, 2** and at **+49°C ±2 for boxes 5, 6**.
- Random vibration performed IAW the specification given in section 20-4 below.
- Take pictures of the ammunition box, including inside wall/flaps if signs of wear appear, cardboard boxes and ammunition itself before and after each test/orientation.
- Use the following orientations for the vibration.



20-4 – CH-146 Griffon Helicopter Vibration Pattern

Test Axis: Vertical, Transverse, and Longitudinal
Test Duration: **1 hours / axis**
Equivalence Factor: 1 hour / axis represents 6 hours flight time
Vibration Spectrum: **Fixed Sine on broadband random vibration**
Control Strategy: Multi-point control (Average)
Griffon Rotation Speed: 5.40 Hz / 2 Blades

1. Use the maximum control system roll-off rate at the 5 and 500 Hz breakpoints.

Schedule Description

The Figure D-1 test schedule depicts the test severity for material transported as secured cargo on the floor of a helicopter during normal flight operations. The figure provided is a general representation of the vibration environment due to structural and acoustic excitation from the engine, main rotor, and the aerodynamic flow over the external airframe. The fixed sine amplitudes and frequencies are determined from the main rotor fundamental frequency in Table D-1. The test schedule is an envelope applicable to the specified test axes (vertical, transverse, longitudinal) and was derived from vibration measurements on various helicopters. Tailoring of the fixed sine amplitude and bandwidth based on measured data is desirable to represent the required helicopter. The test schedule utilized must include fixed sine components at the fundamental main rotor blade passage frequency and the harmonics of the simulated helicopter. The use of several sines on random spectra, or bandwidths, to represent multiple engine operating conditions or shaft harmonics may be necessary. The measurement of flight data is also suggested to tailor the low frequency response and package to airframe coupling characteristics. Figure D-1 is not representative of severe vibration due to aircraft combat maneuvers. Figure D-1 is developed from multiple data sources.

Helicopter Cargo Schedule Breakpoints					
Random Breakpoints, all axes		Fixed Sine Harmonic Amplitudes, G_{peak}			
Frequency Hz	ASD, G^2/Hz	Sine Peak	Vertical	Transverse	Longitudinal
5	0.004	10.8 Hz	1.73	1.73	1.0
100	0.004	21.6 Hz	1.73	1.73	1.0
500	0.001	32.4 Hz	1.73	1.73	1.0
Random Grms = 1.05					

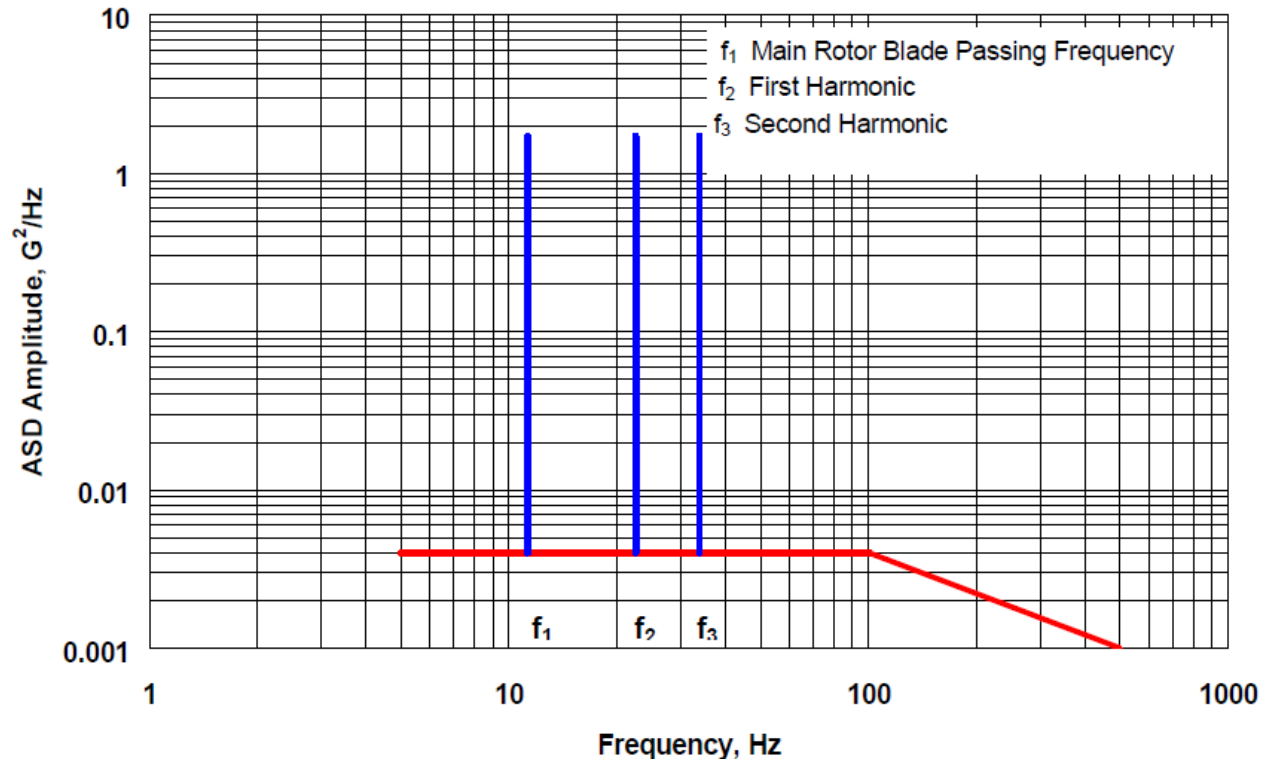

Figure D-2: Helicopter Cargo

Ammunition S3
Sequential Phase 21 – Tactical Wheeled Vehicle – All Terrain

21-1 – Test general information

Made IAW **AECTP 400, Method 401**

AMMO BOX: 51, 52 (cold branch), 55, 56 (hot branch)

21-2 – Material

Ammunition	4 C181 Boxes of Testing Lot: IVI18C09-01 / IVI17L08-01 as seen above
Conditioning	Vibration & Conditioning unit

21-3 – Methodology

- Test is done at **-46°C ±2 for boxes 1, 2** and at **+49°C ±2 for boxes 5, 6**.
- Random vibration performed IAW the specification given in section 21-4 below.
- Take pictures of the ammunition box, including inside wall/flaps if signs of wear appear, cardboard boxes and ammunition itself before and after each test/orientation.
- Use the following orientations for the vibration.



21-4 – Tactical Wheeled Vehicle – All Terrain Test Description

Test Axis: Vertical, Transverse, and Longitudinal
Test Duration: 40 minutes / **axis**
Equivalence Factor: 40 minutes / axis represents 805 km distance.
Vibration Spectrum: **Broadband (500 Hz) random vibration**
Control Strategy: Multi-point control (Average)

1. Use the maximum control system roll-off rate at the 5 and 500 Hz breakpoints.
2. The test schedules are derived for a control accelerometer(s) located at the material and transportation platform interface.

Schedule Description

The Figure A-2 schedules represent the test severity at the cargo bed of a composite of tactical wheeled military vehicles. Transportation of secured cargo on the vehicle bed area over cross-country unimproved roads is the typical environment. The vertical axis is up from the ground (vehicle cargo bed), transverse is perpendicular across the road, and longitudinal is parallel to the road. The test schedules are based upon data measured at multiple locations of the cargo bed of different configurations of single and multiple axle trucks and tractor-trailer combinations. The test vehicle load capacity ratings ranged from 1-1/2 to 12 tons. The data were collected from vehicle operation over terrain representative of military operations. These road terrains include cobblestone, sinusoidal washboard, and spaced bump road surface irregularities. Data measurements were conducted at multiple speeds up to the maximum safe vehicle operational speed, and with the cargo area loaded to 75% of rated capacity for cross-country conditions. To obtain the final test schedule the data were processed by combination of terrain types and measurement locations in each axis to provide a conservative estimate of the expected environment vibration amplitude. An exaggeration factor has been applied to the measured data to increase the ASD amplitude and decrease the laboratory simulation test duration. Because cross-country operation is the most severe military wheeled vehicle operational environment, these schedules are an envelope of the worst case in-service field vibration. The test schedules are not representative of the lower amplitude vibration for vehicle operation limited to paved and/or secondary roads. The test may also not accurately represent the installed equipment vibration for material mounted in locations other than the cargo area. See ITOP 1-2-601 for additional wheeled vehicle vibration test schedules. Figure A-2 is developed from ITOP 1-2- 601 and other data sources.

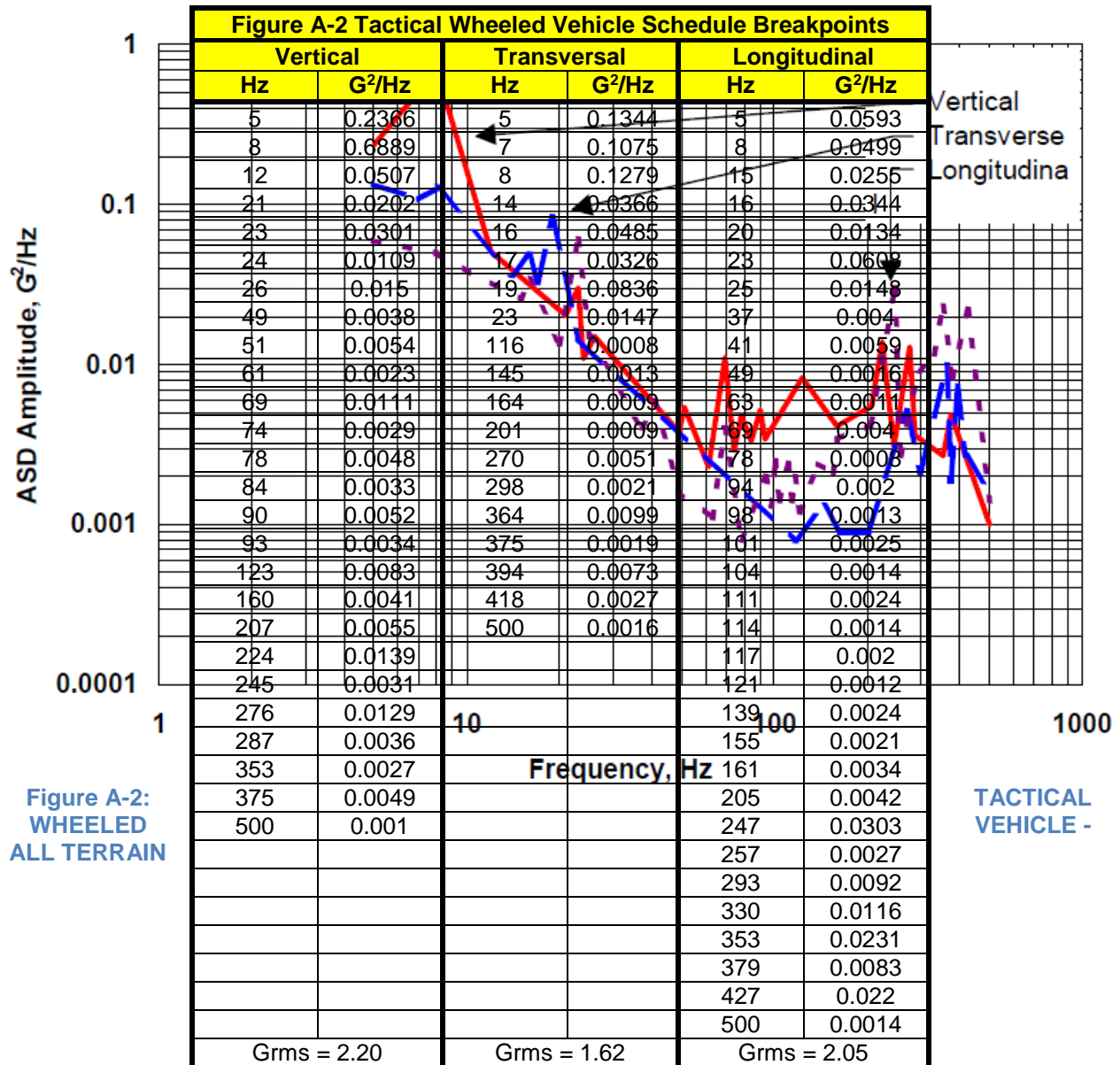

Ammunition S3
Sequential Phase 22 – Two-Wheeled Trailer

22-1 – Test general information

Made IAW **AECTP 400, Method 401**

AMMO BOX: 51, 52 (cold branch), 55, 56 (hot branch)

22-2 – Material

Ammunition	4 C181 Boxes of Testing Lot IVI18C09-01 / IVI17L08-01 as seen above
Conditioning	Vibration & Conditioning unit

22-3 – Methodology

- Test is done at **-46°C ±2 for boxes 1, 2** and at **+49°C ±2 for boxes 5, 6**.
- Random vibration performed IAW the specification given in section 22-4 below.
- Take pictures of the ammunition box, including inside wall/flaps if signs of wear appear, cardboard boxes and ammunition itself before and after each test/orientation.
- Use the following orientations for the vibration.

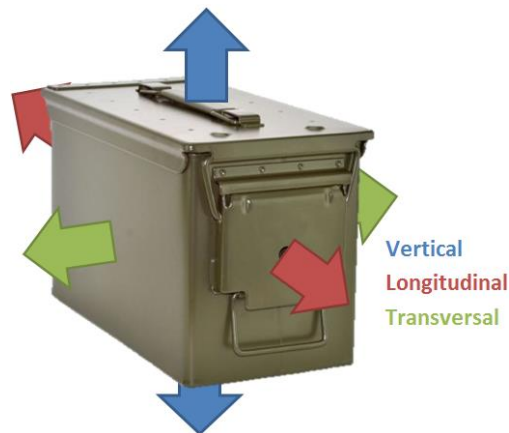

22-4 – Two-Wheel Trailer Description

Test Axis:	Vertical, Transverse, and Longitudinal
Test Duration:	32 minutes / axis
Equivalence Factor:	32 minutes / axis represents a 52 km distance.
Vibration Spectrum:	Broadband (500 Hz) random vibration
Control Strategy:	Multi-point control (Average)

1. Use the maximum control system roll-off rate at the 5 and 500 Hz breakpoints.
2. The test schedules are derived from a control accelerometer(s) located at the material and transportation platform interface.
3. The acceleration amplitude of the vertical axis vibration requires a high displacement exciter capability, approximately 2.6 inch pk-pk displacement. If a servo-hydraulic test system is used that is not capable of adequate high frequency simulation, then the test may be performed in two steps by using two exciters with adjacent frequency ranges. The test duration for each axis shall be used on each test systems. Alternatively, performance of the test on test systems with inadequate displacement by attenuation of the low frequency ASD amplitude requires an authorization from the test requesting agency to perform the vibration test.

Schedule Description

The Figure A-3 schedules represent the test severity at the cargo bed of a composite of two-wheeled vehicle towed trailers. Transportation of secured cargo on the trailer bed area over cross-country unimproved roads is the typical environment. The vertical axis is up from the ground (trailer cargo bed), transverse is perpendicular across the road, and longitudinal is parallel to the road. These curves are based upon data measured at multiple locations of the cargo bed of different configurations of single axle two-wheel trailers. The test trailer load capacity ratings ranged from 1/4 to 1-1/2 ton. The data were collected from trailer operation over terrain representative of military operations. These road terrains include cobblestone, sinusoidal washboard, and spaced bump road surface irregularities. Data measurements were conducted at multiple speeds up to the maximum safe vehicle operational speed, and with the cargo area loaded to 75% of rated capacity for cross-country conditions. To obtain the final test schedule the data were processed by combination of terrain types and measurement locations in each axis to provide a conservative estimate of the expected environment vibration amplitude. An exaggeration factor has not been applied to the measured data. Because cross-country operation is the most severe military wheeled trailer operational environment, these schedules are an envelope of the worst case in-service field vibration. The test schedules are not representative of the lower amplitude vibration for trailer operation limited to paved and/or secondary roads. Figure A-2 is developed from ITOP 1-2- 601.

Figure A-3 Two Wheel Trailer Schedule Breakpoints					
Vertical		Transversal		Longitudinal	
Hz	G²/Hz	Hz	G²/Hz	Hz	G²/Hz
5	0.2221	5	0.0451	5	0.0536
8	0.5432	6	0.0303	8	0.1129
10	0.042	7	0.0761	13	0.0137
13	0.0256	13	0.0127	16	0.0303
15	0.0726	15	0.0327	18	0.0193
16	0.0249	16	0.0134	19	0.0334
19	0.0464	21	0.0102	20	0.0184
20	0.0243	23	0.0261	23	0.0369
21	0.0226	25	0.009	27	0.0079
23	0.0362	26	0.009	30	0.0203
27	0.0124	30	0.0137	31	0.0133
30	0.0282	34	0.0053	33	0.0261
32	0.0195	36	0.0079	36	0.006
33	0.0353	46	0.0039	49	0.0042
35	0.0237	50	0.0067	53	0.0077
36	0.04	55	0.0042	56	0.0036
41	0.0102	104	0.0033	59	0.0062
45	0.0232	107	0.0044	62	0.0044
50	0.0113	111	0.0032	65	0.0121
94	0.0262	147	0.0029	71	0.0026
107	0.1866	161	0.0052	93	0.0115
114	0.022	175	0.0022	107	0.1344
138	0.0864	233	0.0013	115	0.0151
145	0.0262	257	0.0027	136	0.0836
185	0.0595	314	0.0016	149	0.0261
260	0.061	333	0.0053	157	0.0485
320	0.0104	339	0.0009	164	0.0261
339	0.0256	382	0.0017	183	0.0577
343	0.0137	406	0.0008	281	0.003
357	0.0249	482	0.0019	339	0.0184
471	0.0026	500	0.0007	382	0.0014
481	0.0059			439	0.0051
500	0.0017			462	0.0019
				485	0.0044
				500	0.0014
Grms = 3.99		Grms = 1.29		Grms = 2.73	

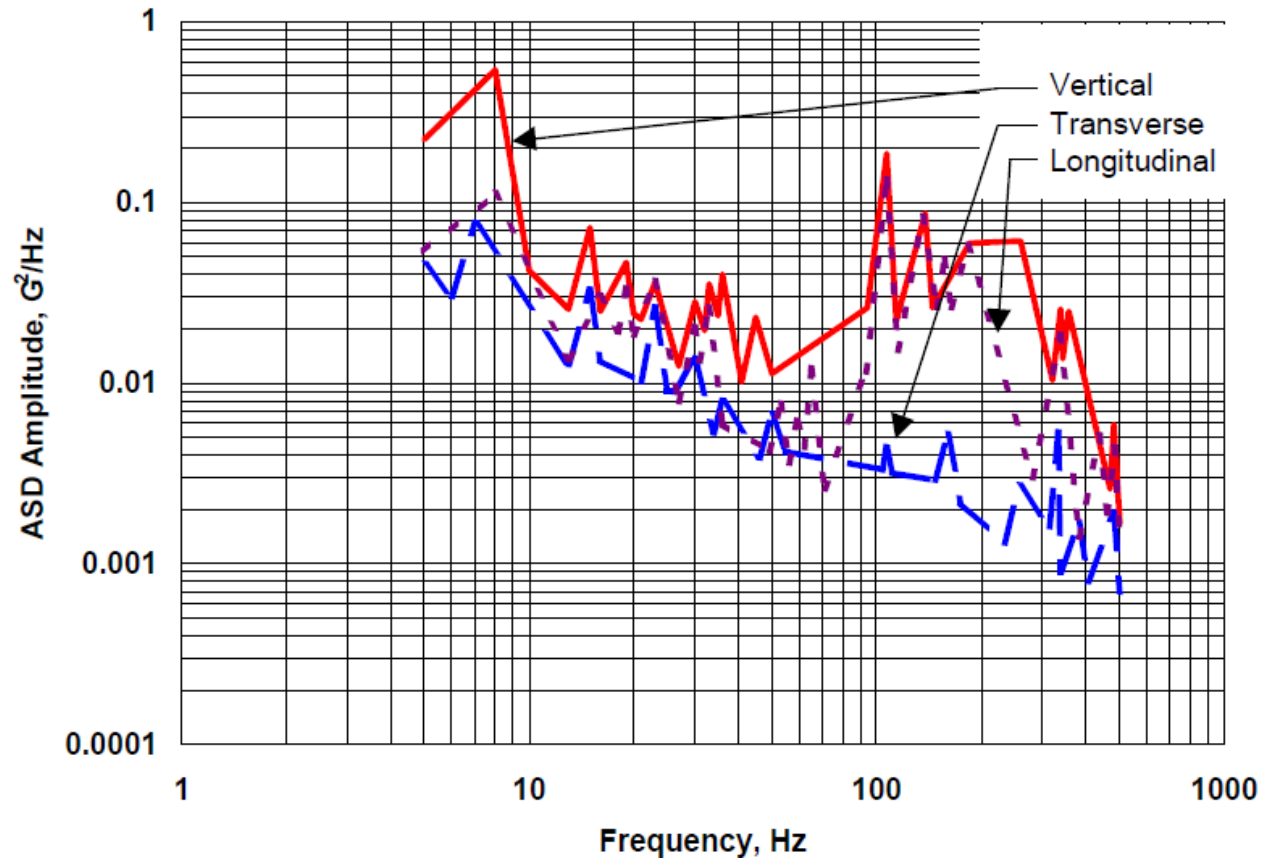

Figure A-3: Two-wheeled trailer

ANNEX “D”

Pricing Schedule

Bidders are required to provide a price for each line item indicated. If a price is left blank it will be interpreted as an offered price of \$0.00. If a price of an item is included in another item, this should be indicated by noting, “Price of this item is included in item xx (Insert item number)”. If there is not an applicable price for an item, this should be indicated as “N/A”. The prices must be indicated in compliance with Basis of Payment

Option Year one can only be exercised in the initial year of the contract. Option Year two can only be exercised during Option Year one of the contract. Finally, Option Year three of the contract can only be exercised during Option year 2 of the contract.

Description	Price	Tax (if applicable)	Total
Perform vibration testing based on the requirements outlined in AD1 in Annex C as well as perform the testing as outlined in AD2 in Annex D and provide reports as detailed in the Statement of Work in Annex A, section 5.1.4			
Option Year 1 : Perform vibration testing based on the requirements outlined in AD1 in Annex C as well as perform the testing as outlined in AD2 in Annex D and provide reports as detailed in the Statement of Work in Annex A, section 5.1.4			
Option Year 2: Perform vibration testing based on the requirements outlined in AD1 in Annex C as well as perform the testing as outlined in AD2 in Annex D and provide reports as detailed in the Statement of Work in Annex A, section 5.1.4			
Option Year 3: Perform vibration testing based on the requirements outlined in AD1 in Annex C as well as perform the testing as outlined in AD2 in Annex D and provide reports as detailed in the Statement of Work in Annex A, section 5.1.4			
Total			

ANNEX “E”

MANDATORY EVALUATION CRITERIA

In their proposals, bidders must demonstrate they meet the following mandatory criteria. Failure to meet any of the mandatory criteria will render the bid non-compliant and it will be given no further consideration.

	CRITERIA	MET	NOT MET
M1	The contractor must be able to perform on the test items, horizontal and vertical vibration with a multi-point control strategy that follows the vibration profiles described in AD2, at temperature between -46°C and +49°C and within the tolerance described in AD1.		
M2	The contractor must record the acceleration output of the vibrations in order to confirm that the vibration profiles were in accordance with profile found in AD2.		
M3	The contractor must be able to perform a drop test of the test item from a 1.7m height on a 50mm thick plywood backed by concrete as described in AD2.		
M4	The contractor must be able to perform a loose cargo test on the test items with a 25mm peak to peak circular synchronous motion at 5hz as described in AD2.		
M5	The contractor must be able to meet via video conference in the test area to discuss test results.		

ANNEX "F"

ELECTRONIC PAYMENT INSTRUMENTS

The Bidder accepts any of the following Electronic Payment Instrument(s):

- Direct Deposit (Domestic and International);
- Electronic Data Interchange (EDI);
- Wire Transfer (International Only);