

RETURN BIDS TO:
RETOURNER LES SOUMISSIONS À:
 Veterans Affairs Canada
 Procurement & Contracting
 Attn: Sine MacAdam
sine.macadam@veterans.gc.a

REQUEST FOR PROPOSAL

DEMANDE DE PROPOSITION

v.02_e

Proposal To: Veterans Affairs Canada

We hereby offer to sell to Her Majesty the Queen in right of Canada, in accordance with the terms and conditions set out herein, referred to herein or attached hereto, the goods, services, and construction listed herein and on any attached sheets at the price(s) set out thereof.

Proposition aux: Anciens Combattants Canada

Nous offrons par la présente de vendre à Sa Majesté la Reine du chef du Canada, aux conditions énoncées ou incluses par référence dans la présente et aux annexes ci-jointes, les biens, services et construction énumérés ici sur toute feuille ci-annexées, au(x) prix indiqué(s)

Instructions: See Herein
Instructions : Voir aux présentes

Comments - Commentaires

Vendor/Firm Name and address
Raison sociale et adresse du fournisseur/de l'entrepreneur

Issuing Office – Bureau de distribution
 Veterans Affairs Canada
 Procurement & Contracting

| | |
|---------------------------------------------------------------------------------------------------------------------------------------------|------------------------------------------------------------------------|
| Title – Sujet Cemetery Maintenance, British Columbia | |
| Solicitation No. – N° de l'invitation 3000740228 | Date 2022-03-17 |
| GETS Reference No. – N° de reference de SEAG - | |
| File No. – N° de dossier | CCC No. / N° CCC - FMS No. / N° VME |
| Solicitation Closes – L'invitation prend fin | |
| at – à 2:00PM on – le 2022-04-12 | Time Zone Fuseau horaire Atlantic Daylight Time ADT |
| F.O.B. - F.A.B. Plant-Usine: <input type="checkbox"/> Destination: <input type="checkbox"/> Other-Autre: <input type="checkbox"/> | |
| Address Inquiries to : - Adresser toutes questions à: Sine MacAdam | Buyer Id – Id de l'acheteur msmacada |
| Telephone No. – N° de téléphone : 902-626-5288 | FAX No. – N° de FAX |
| Destination – of Goods, Services, and Construction: Destination – des biens, services et construction : See Herein | |

| | |
|-------------------------------------------------------------------------------------------------------------------------------------------------------------------------------------------------------------------------------------|-----------------------------------------------|
| Delivery required - Livraison exigée See Herein | Delivered Offered – Livraison proposée |
| Vendor/firm Name and address Raison sociale et adresse du fournisseur/de l'entrepreneur | |
| Facsimile No. – N° de télécopieur Telephone No. – N° de téléphone | |
| Name and title of person authorized to sign on behalf of Vendor/firm (type or print)- Nom et titre de la personne autorisée à signer au nom du fournisseur/de l'entrepreneur (taper ou écrire en caractères d'imprimerie) | |
| Signature | Date |

TABLE OF CONTENTS

| | |
|-------------------------------------------------------------------------|-----------|
| PART 1 - GENERAL INFORMATION | 3 |
| 1.1 INTRODUCTION..... | 3 |
| 1.2 SUMMARY | 3 |
| 1.3 DEBRIEFINGS..... | 3 |
| PART 2 - BIDDER INSTRUCTIONS | 5 |
| 2.1 STANDARD INSTRUCTIONS, CLAUSES AND CONDITIONS..... | 5 |
| 2.2 SUBMISSION OF BIDS..... | 5 |
| 2.3 FORMER PUBLIC SERVANT..... | 5 |
| 2.4 ENQUIRIES - BID SOLICITATION..... | 6 |
| 2.5 APPLICABLE LAWS..... | 6 |
| 2.6 IMPROVEMENT OF REQUIREMENT DURING SOLICITATION PERIOD..... | 7 |
| 2.7 BID CHALLENGE AND RECOURSE MECHANISMS..... | 7 |
| PART 3 - BID PREPARATION INSTRUCTIONS..... | 8 |
| 3.1 BID PREPARATION INSTRUCTIONS | 8 |
| PART 4 - EVALUATION PROCEDURES AND BASIS OF SELECTION | 9 |
| 4.1 EVALUATION PROCEDURES..... | 9 |
| 4.2 BASIS OF SELECTION..... | 13 |
| PART 5 – CERTIFICATIONS AND ADDITIONAL INFORMATION | 14 |
| 5.1 CERTIFICATIONS REQUIRED WITH THE BID..... | 14 |
| 5.2 CERTIFICATIONS PRECEDENT TO CONTRACT AWARD | 14 |
| PART 6 - RESULTING CONTRACT CLAUSES | 15 |
| 6.1 STATEMENT OF WORK..... | 15 |
| 6.2 STANDARD CLAUSES AND CONDITIONS..... | 15 |
| 6.3 SECURITY REQUIREMENTS | 15 |
| 6.4 TERM OF CONTRACT | 15 |
| 6.5 AUTHORITIES | 16 |
| 6.6 PROACTIVE DISCLOSURE OF CONTRACTS WITH FORMER PUBLIC SERVANTS | 16 |
| 6.7 PAYMENT | 17 |
| 6.9 CERTIFICATIONS AND ADDITIONAL INFORMATION..... | 18 |
| 6.10 PRIORITY OF DOCUMENTS | 18 |
| 6.11 INSURANCE | 18 |
| 6.12 SITE REGULATIONS | 18 |
| 6.13 DISPUTE RESOLUTION..... | 18 |
| 6.14 OFFICE OF THE PROCUREMENT OMBUDSMAN..... | 19 |

PART 1 - GENERAL INFORMATION

1.1 Introduction

The bid solicitation is divided into six parts plus attachments and annexes, as follows:

- Part 1 General Information: provides a general description of the requirement;
- Part 2 Bidder Instructions: provides the instructions, clauses and conditions applicable to the bid solicitation;
- Part 3 Bid Preparation Instructions: provides Bidders with instructions on how to prepare their bid;
- Part 4 Evaluation Procedures and Basis of Selection: indicates how the evaluation will be conducted, the evaluation criteria that must be addressed in the bid, and the basis of selection;
- Part 5 Certifications and Additional Information: includes the certifications and additional information to be provided;
- Part 6 Resulting Contract Clauses: includes the clauses and conditions that will apply to any resulting contract.

The Annexes include the Statement of Work, the Basis of Payment, Mandatory Technical Criteria, and Bidders Project Template.

The Attachments include the National Technical Maintenance Manual – Sections 4 and 5, Pinning Instructions, Specifications for Taking Photos of Repaired/New Markers, and List of Repairs and Cemeteries.

1.2 Summary

Veterans Affairs Canada (VAC) has identified a number of repairs to Veterans grave markers, located in British Columbia to be completed in 2022. See attached list for summary of cemeteries and required repairs.

Area A – Zone BC04 – Kootenay Boundary
Area B – Zone BC07 – Greater Vancouver
Area C – Zone BC10 – Port Alberni/Tofino
Area D – Zone BC15 – Thompson/Nicola
Area E – Zone BC17 – North Okanagan
Area F – Zone BC19 - Cariboo
Area G – Zone BC20 – Mount Waddington
Area H – Zone BC22 – Skeena/Haida Gwaii
Area I – Zone BC23 – Kitimat/Stikine
Area J – Zone BC24 – Bulkley/Nechako
Area K – Zone BC25 – Fraser/Fort George
Area L – Zone BC26 – Peace River
Area M – Zone BC28 – Northern Rockies

1.3 Debriefings

Bidders may request a debriefing on the results of the bid solicitation process. Bidders should make the request to the Contracting Authority within 15 working days from receipt of the results of the bid solicitation process. The debriefing may be in writing, by telephone or in person.

1.4 Phased Bid Compliance Process

The Phased Bid Compliance Process applies to this requirement.

PART 2 - BIDDER INSTRUCTIONS

2.1 Standard Instructions, Clauses and Conditions

All instructions, clauses and conditions identified in the bid solicitation by number, date and title are set out in the [Standard Acquisition Clauses and Conditions Manual](https://buyandsell.gc.ca/policy-and-guidelines/standard-acquisition-clauses-and-conditions-manual) (<https://buyandsell.gc.ca/policy-and-guidelines/standard-acquisition-clauses-and-conditions-manual>) issued by Public Works and Government Services Canada.

Bidders who submit a bid agree to be bound by the instructions, clauses and conditions of the bid solicitation and accept the clauses and conditions of the resulting contract.

The [2003](#) (2020-05-28), Standard Instructions - Goods or Services - Competitive Requirements, are incorporated by reference into and form part of the bid solicitation.

Subsection 5.4 of [2003](#), Standard Instructions - Goods or Services - Competitive Requirements, is amended as follows:

Delete: 60 days
Insert: 90 days

2.2 Submission of Bids

Bids must be submitted only to Veterans Affairs Canada by the date, time and place indicated in the bid solicitation.

Due to the nature of the bid solicitation, bids transmitted by facsimile, mail or courier will not be accepted.

2.3 Former Public Servant

Contracts awarded to former public servants (FPS) in receipt of a pension or of a lump sum payment must bear the closest public scrutiny, and reflect fairness in the spending of public funds. In order to comply with Treasury Board policies and directives on contracts awarded to FPSs, bidders must provide the information required below before contract award. If the answer to the questions and, as applicable the information required have not been received by the time the evaluation of bids is completed, Canada will inform the Bidder of a time frame within which to provide the information. Failure to comply with Canada's request and meet the requirement within the prescribed time frame will render the bid non-responsive.

Definitions

For the purposes of this clause, "former public servant" is any former member of a department as defined in the Financial Administration Act, R.S., 1985, c. F-11, a former member of the Canadian Armed Forces or a former member of the Royal Canadian Mounted Police. A former public servant may be: a. an individual; b. an individual who has incorporated; c. a partnership made of former public servants; or d. a sole proprietorship or entity where the affected individual has a controlling or major interest in the entity.

"lump sum payment period" means the period measured in weeks of salary, for which payment has been made to facilitate the transition to retirement or to other employment as a result of the implementation of various programs to reduce the size of the Public Service. The lump sum payment period does not include the period of severance pay, which is measured in a like manner.

"pension" means a pension or annual allowance paid under the Public Service Superannuation Act (PSSA), R.S., 1985, c. P-36, and any increases paid pursuant to the Supplementary Retirement Benefits Act, R.S., 1985, c. S-24 as it affects the PSSA. It does not include pensions payable pursuant to the Canadian Forces Superannuation Act, R.S., 1985, c. C-17, the Defence Services Pension Continuation

Act, 1970, c. D-3, the Royal Canadian Mounted Police Pension Continuation Act, 1970, c. R-10, and the Royal Canadian Mounted Police Superannuation Act, R.S., 1985, c. R-11, the Members of Parliament Retiring Allowances Act, R.S. 1985, c. M-5, and that portion of pension payable to the Canada Pension Plan Act, R.S., 1985, c. C-8.

Former Public Servant in Receipt of a Pension

As per the above definitions, is the Bidder a FPS in receipt of a pension? Yes () No ()

If so, the Bidder must provide the following information, for all FPSs in receipt of a pension, as applicable:

- a. name of former public servant;
- b. date of termination of employment or retirement from the Public Service.

By providing this information, Bidders agree that the successful Bidder's status, with respect to being a former public servant in receipt of a pension, will be reported on departmental websites as part of the published proactive disclosure reports in accordance with Contracting Policy Notice: 2019-01 and the Guidelines on the Proactive Disclosure of Contracts.

Work Force Adjustment Directive

Is the Bidder a FPS who received a lump sum payment pursuant to the terms of the Work Force Adjustment Directive? Yes () No ()

If so, the Bidder must provide the following information:

- a. name of former public servant;
- b. conditions of the lump sum payment incentive;
- c. date of termination of employment;
- d. amount of lump sum payment;
- e. rate of pay on which lump sum payment is based;
- f. period of lump sum payment including start date, end date and number of weeks;
- g. number and amount (professional fees) of other contracts subject to the restrictions of a work force adjustment program.

2.4 Enquiries - Bid Solicitation

All enquiries must be submitted in writing to the Contracting Authority no later than 5 (five) calendar days before the bid closing date. Enquiries received after that time may not be answered.

Bidders should reference as accurately as possible the numbered item of the bid solicitation to which the enquiry relates. Care should be taken by Bidders to explain each question in sufficient detail in order to enable Canada to provide an accurate answer. Technical enquiries that are of a proprietary nature must be clearly marked "proprietary" at each relevant item. Items identified as "proprietary" will be treated as such except where Canada determines that the enquiry is not of a proprietary nature. Canada may edit the question(s) or may request that the Bidder do so, so that the proprietary nature of the question(s) is eliminated and the enquiry can be answered to all Bidders. Enquiries not submitted in a form that can be distributed to all Bidders may not be answered by Canada.

2.5 Applicable Laws

Any resulting contract must be interpreted and governed, and the relations between the parties determined, by the laws in force in British Columbia.

Bidders may, at their discretion, substitute the applicable laws of a Canadian province or territory of their choice without affecting the validity of their bid, by deleting the name of the Canadian province or territory specified and inserting the name of the Canadian province or territory of their choice. If no change is made, it acknowledges that the applicable laws specified are acceptable to the Bidders.

2.6 Improvement of Requirement During Solicitation Period

Should bidders consider that the specifications or Statement of Work contained in the bid solicitation could be improved technically or technologically, bidders are invited to make suggestions, in writing, to the Contracting Authority named in the bid solicitation. Bidders must clearly outline the suggested improvement as well as the reason for the suggestion. Suggestions that do not restrict the level of competition nor favour a particular bidder will be given consideration provided they are submitted to the Contracting Authority at least 5 (five) days before the bid closing date. Canada will have the right to accept or reject any or all suggestions.

2.7 Bid Challenge and Recourse Mechanisms

- (a) Several mechanisms are available to potential suppliers to challenge aspects of the procurement process up to and including contract award.
- (b) Canada encourages suppliers to first bring their concerns to the attention of the Contracting Authority. Canada's [Buy and Sell](#) website, under the heading "[Bid Challenge and Recourse Mechanisms](#)" contains information on potential complaint bodies such as:
 - Office of the Procurement Ombudsman (OPO)
 - Canadian International Trade Tribunal (CITT)
- (c) Suppliers should note that there are strict deadlines for filing complaints, and the time periods vary depending on the complaint body in question. Suppliers should therefore act quickly when they want to challenge any aspect of the procurement process.

2.8 Office of the Procurement Ombudsman

The OPO was established by the Government of Canada to provide an impartial, independent venue for Canadian bidders to raise complaints regarding the award of certain federal contracts under \$30,300 for goods and \$121,200 for services. If you have concerns regarding the award of a federal contract below these dollar amounts, you may contact the OPO by e-mail at boa.opo@boa-opo.gc.ca, by telephone at 1-866-734-5169, or by web at www.opo-boa.gc.ca. For more information on OPO's services or to determine if your concerns are within the Ombudsman's mandate, please see the [Procurement Ombudsman Regulations](#) or visit the [Office of the Procurement Ombudsman website](#).

PART 3 - BID PREPARATION INSTRUCTIONS

3.1 Bid Preparation Instructions

The Bidder must submit its bid electronically via email.

The bid must be gathered per section and separated as follows:

Section I: Technical Bid
Section II: Financial Bid
Section III: Certifications
Section IV: Additional Information

Due to the nature of the bid solicitation, bids transmitted by facsimile, mail or courier will not be accepted.

Prices must appear in the financial bid only. No prices must be indicated in any other section of the bid.

Section I: Technical Bid

By submitting a proposal, the Bidder certifies they have read, understand and are capable of performing the work requirements as set out in the Statement of Work and Attachments at Annex "A".

In their technical bid, Bidders should demonstrate how they meet the mandatory technical evaluation criteria at Annex C – Mandatory Technical Evaluation Criteria.

Bidders are only required to submit one technical bid in response to this solicitation.

Section II: Financial Bid

3.1.1 Bidders must submit their financial bid in accordance with the "Financial Evaluation Tables B.1 through B.13 provided at Annex "B" – Basis of Payment. The total amount of Applicable Taxes must be shown separately.

3.1.2 Exchange Rate Fluctuation

C3011T (2013-11-06), Exchange Rate Fluctuation

Section III: Certifications

Bidders must submit the certifications and additional information required under Part 5.

Section IV: Additional Information

Canada requests that the Bidders provide the Contractor's representative contact information in Part 6.

PART 4 - EVALUATION PROCEDURES AND BASIS OF SELECTION

4.1 Evaluation Procedures

- (a) Bids will be assessed in accordance with the entire requirement of the bid solicitation including the technical and financial evaluation criteria.
- (b) An evaluation team composed of representatives of Canada will evaluate the bids.
- (c) Canada will use the Phased Bid Compliance Process (PBCP) as described below.

4.1.1 Phased Bid Compliance

4.1.1.1 (2018-07-19) General

- (a) Canada is conducting the PBCP described below for this requirement.

(b) Notwithstanding any review by Canada at Phase I or II of the PBCP, Bidders are and will remain solely responsible for the accuracy, consistency and completeness of their Bids and Canada does not undertake, by reason of this review, any obligations or responsibility for identifying any or all errors or omissions in Bids or in responses by a Bidder to any communication from Canada.

THE BIDDER ACKNOWLEDGES THAT THE REVIEWS IN PHASE I AND II OF THIS PBCP ARE PRELIMINARY AND DO NOT PRECLUDE A FINDING IN PHASE III THAT THE BID IS NONRESPONSIVE, EVEN FOR MANDATORY REQUIREMENTS WHICH WERE SUBJECT TO REVIEW IN PHASE I OR II AND NOTWITHSTANDING THAT THE BID HAD BEEN FOUND RESPONSIVE IN SUCH EARLIER PHASE. CANADA MAY DEEM A BID TO BE NONRESPONSIVE TO A MANDATORY REQUIREMENT AT ANY PHASE. THE BIDDER ALSO ACKNOWLEDGES THAT ITS RESPONSE TO A NOTICE OR A COMPLIANCE ASSESSMENT REPORT (CAR) (EACH DEFINED BELOW) IN PHASE I OR II MAY NOT BE SUCCESSFUL IN RENDERING ITS BID RESPONSIVE TO THE MANDATORY REQUIREMENTS THAT ARE THE SUBJECT OF THE NOTICE OR CAR, AND MAY RENDER ITS BID NON-RESPONSIVE TO OTHER MANDATORY REQUIREMENTS.

(c) Canada may, in its discretion, request and accept at any time from a Bidder and consider as part of the Bid, any information to correct errors or deficiencies in the Bid that are clerical or administrative, such as, without limitation, failure to sign the Bid or any part or to checkmark a box in a form, or other failure of format or form or failure to acknowledge; failure to provide a procurement business number or contact information such as names, addresses and telephone numbers; inadvertent errors in numbers or calculations that do not change the amount the Bidder has specified as the price or of any component thereof that is subject to evaluation. This shall not limit Canada's right to request or accept any information after the bid solicitation closing in circumstances where the bid solicitation expressly provides for this right. The Bidder will have the time period specified in writing by Canada to provide the necessary documentation. Failure to meet this deadline will result in the Bid being declared non-responsive.

(d) The PBCP does not limit Canada's rights under Standard Acquisition Clauses and Conditions (SACC) 2003 (2019-03-04) Standard Instructions – Goods or Services – Competitive Requirements nor Canada's right to request or accept any information during the solicitation period or after bid solicitation closing in circumstances where the bid solicitation expressly provides for this right, or in the circumstances described in subsection (c).

(e) Canada will send any Notice or CAR by any method Canada chooses, in its absolute discretion. The Bidder must submit its response by the method stipulated in the Notice or CAR. Responses are deemed to be received by Canada at the date and time they are delivered to Canada by the method and at the address specified in the Notice or CAR. An email response permitted by the Notice or CAR is deemed received by Canada on the date and time it is received in Canada's email inbox at Canada's email address specified in the Notice or CAR. A Notice or CAR sent by Canada to the Bidder at any address

provided by the Bidder in or pursuant to the Bid is deemed received by the Bidder on the date it is sent by Canada. Canada is not responsible for late receipt by Canada of a response, however caused.

4.1.1.2 (2018-03-13) Phase 1: Financial Bid

(a) After the closing date and time of this bid solicitation, Canada will examine the Bid to determine whether it includes a Financial Bid and whether any Financial Bid includes all information required by the solicitation. Canada's review in Phase I will be limited to identifying whether any information that is required under the bid solicitation to be included in the Financial Bid is missing from the Financial Bid. This review will not assess whether the Financial Bid meets any standard or is responsive to all solicitation requirements.

(b) Canada's review in Phase I will be performed by officials of Veterans Affairs Canada.

(c) If Canada determines, in its absolute discretion that there is no Financial Bid or that the Financial Bid is missing all of the information required by the bid solicitation to be included in the Financial Bid, then the Bid will be considered non-responsive and will be given no further consideration.

(d) For Bids other than those described in c), Canada will send a written notice to the Bidder ("Notice") identifying where the Financial Bid is missing information. A Bidder, whose Financial Bid has been found responsive to the requirements that are reviewed at Phase I, will not receive a Notice. Such Bidders shall not be entitled to submit any additional information in respect of their Financial Bid.

(e) The Bidders who have been sent a Notice shall have the time period specified in the Notice (the "Remedy Period") to remedy the matters identified in the Notice by providing to Canada, in writing, additional information or clarification in response to the Notice. Responses received after the end of the Remedy Period will not be considered by Canada, except in circumstances and on terms expressly provided for in the Notice.

(f) In its response to the Notice, the Bidder will be entitled to remedy only that part of its Financial Bid which is identified in the Notice. For instance, where the Notice states that a required line item has been left blank, only the missing information may be added to the Financial Bid, except that, in those instances where the addition of such information will necessarily result in a change to other calculations previously submitted in its Financial Bid, (for example, the calculation to determine a total price), such necessary adjustments shall be identified by the Bidder and only these adjustments shall be made. All submitted information must comply with the requirements of this solicitation.

(g) Any other changes to the Financial Bid submitted by the Bidder will be considered to be new information and will be disregarded. There will be no change permitted to any other Section of the Bidder's Bid. Information submitted in accordance with the requirements of this solicitation in response to the Notice will replace, in full, only that part of the original Financial Bid as is permitted above, and will be used for the remainder of the bid evaluation process.

(h) Canada will determine whether the Financial Bid is responsive to the requirements reviewed at Phase I, considering such additional information or clarification as may have been provided by the Bidder in accordance with this Section. If the Financial Bid is not found responsive for the requirements reviewed at Phase I to the satisfaction of Canada, then the Bid shall be considered non-responsive and will receive no further consideration.

(i) Only Bids found responsive to the requirements reviewed in Phase I to the satisfaction of Canada, will receive a Phase II review.

4.1.1.3 (2018-03-13) Phase II: Technical Bid

(a) Canada's review at Phase II will be limited to a review of the Technical Bid to identify any instances where the Bidder has failed to meet any Eligible Mandatory Criterion. This review will not assess whether the Technical Bid meets any standard or is responsive to all solicitation requirements. Eligible Mandatory Criteria are all mandatory technical criteria that are identified in this solicitation as being subject to the PBCP. Mandatory technical criteria that are not identified in the solicitation as being subject to the PBCP, will not be evaluated until Phase III.

(b) Canada will send a written notice to the Bidder (Compliance Assessment Report or "CAR") identifying any Eligible Mandatory Criteria that the Bid has failed to meet. A Bidder whose Bid has been found responsive to the requirements that are reviewed at Phase II will receive a CAR that states that its Bid has been found responsive to the requirements reviewed at Phase II. Such Bidder shall not be entitled to submit any response to the CAR.

(c) A Bidder shall have the period specified in the CAR (the "Remedy Period") to remedy the failure to meet any Eligible Mandatory Criterion identified in the CAR by providing to Canada in writing additional or different information or clarification in response to the CAR. Responses received after the end of the Remedy Period will not be considered by Canada, except in circumstances and on terms expressly provided for in the CAR.

(d) The Bidder's response must address only the Eligible Mandatory Criteria listed in the CAR as not having been achieved, and must include only such information as is necessary to achieve such compliance. Any additional information provided by the Bidder which is not necessary to achieve such compliance will not be considered by Canada, except that, in those instances where such a response to the Eligible Mandatory Criteria specified in the CAR will necessarily result in a consequential change to other parts of the Bid, the Bidder shall identify such additional changes, provided that its response must not include any change to the Financial Bid.

(e) The Bidder's response to the CAR should identify in each case the Eligible Mandatory Criterion in the CAR to which it is responding, including identifying in the corresponding section of the original Bid, the wording of the proposed change to that section, and the wording and location in the Bid of any other consequential changes that necessarily result from such change. In respect of any such consequential change, the Bidder must include a rationale explaining why such consequential change is a necessary result of the change proposed to meet the Eligible Mandatory Criterion. It is not up to Canada to revise the Bidder's Bid, and failure of the Bidder to do so in accordance with this subparagraph is at the Bidder's own risk. All submitted information must comply with the requirements of this solicitation.

(f) Any changes to the Bid submitted by the Bidder other than as permitted in this solicitation, will be considered to be new information and will be disregarded. Information submitted in accordance with the requirements of this solicitation in response to the CAR will replace, in full, only that part of the original Bid as is permitted in this Section.

(g) Additional or different information submitted during Phase II permitted by this section will be considered as included in the Bid, but will be considered by Canada in the evaluation of the Bid at Phase II only for the purpose of determining whether the Bid meets the Eligible Mandatory Criteria. It will not be used at any Phase of the evaluation to increase any score that the original Bid would achieve without the benefit of such additional or different information. For instance, an Eligible Mandatory Criterion that requires a mandatory minimum number of points to achieve compliance will be assessed at Phase II to determine whether such mandatory minimum score would be achieved with such additional or different information submitted by the Bidder in response to the CAR. If so, the Bid will be considered responsive in respect of such Eligible Mandatory Criterion, and the additional or different information submitted by the Bidder shall bind the Bidder as part of its Bid, but the Bidder's original score, which was less than the mandatory minimum for such Eligible Mandatory Criterion, will not change, and it will be that original score that is used to calculate any score for the Bid. (h) Canada will determine whether the Bid is responsive for the requirements reviewed at Phase II, considering such additional or different information

or clarification as may have been provided by the Bidder in accordance with this Section. If the Bid is not found responsive for the requirements reviewed at Phase II to the satisfaction of Canada, then the Bid shall be considered non-responsive and will receive no further consideration. (i) Only Bids found responsive to the requirements reviewed in Phase II to the satisfaction of Canada, will receive a Phase III evaluation.

4.1.1.4 (2018-03-13) Phase III: Final Evaluation of the Bid

(a) In Phase III, Canada will complete the evaluation of all Bids found responsive to the requirements reviewed at Phase II. Bids will be assessed in accordance with the entire requirement of the bid solicitation including the technical and financial evaluation criteria.

(b) A Bid is non-responsive and will receive no further consideration if it does not meet all mandatory evaluation criteria of the solicitation.

4.1.2 Technical Evaluation

4.1.2.1. Mandatory Technical Criteria

The Phased Bid Compliance Process will apply to all mandatory technical criteria. Bidders must demonstrate their compliance with all mandatory technical evaluation criteria detailed at Annex C – Mandatory Technical Evaluation Criteria, by providing information describing completely and in detail how each requirement is met. Failure to meet any of the mandatory technical criteria will result in the Bidder's technical bid being declared non-responsive and given no further consideration.

1. The Bidder must demonstrate a minimum of 12 months of cumulative experience providing two (2) or more aspects of grave marker maintenance.
2. The Bidder must demonstrate a minimum of 12 months of cumulative experience performing landscaping tasks.

Definitions:

Grave marker maintenance: Includes the alignment, levelling, cleaning, grouting, of grave markers/monuments and the installation of new bases, foundations and/or grave markers.

Client or organization: Includes but is not limited to work experience with funeral home(s), church(es), community group(s), municipalities, Commonwealth War Graves Commission, Veterans Affairs Canada.

4.1.3 Financial Evaluation

Financial bids will be evaluated separately for each zone.

4.1.3.1 Mandatory Financial Criteria

- a. Bidders must submit their financial bid using the Financial Evaluation Tables B.1 through B.13 provided at Annex B – Basis of Payment. The total amount of Applicable Taxes must be shown separately within each Financial Evaluation Table submitted.
- b. Bidders must submit firm prices for one or multiple zones.
- c. Bidders must submit firm prices for the entire period of the proposed contract.
- d. Bids must include firm prices for all work listed in the zone for which they are bidding.
- e. The zones are as follows:

Area A – Zone BC04 – Kootenay Boundary
Area B – Zone BC07 – Greater Vancouver
Area C – Zone BC10 – Port Alberni/Tofino
Area D – Zone BC15 – Thompson/Nicola
Area E – Zone BC17 – North Okanagan
Area F – Zone BC19 - Cariboo
Area G – Zone BC20 – Mount Waddington
Area H – Zone BC22 – Skeena/Haida Gwaii
Area I – Zone BC23 – Kitimat/Stikine
Area J – Zone BC24 – Bulkley/Nechako
Area K – Zone BC25 – Fraser/Fort George
Area L – Zone BC26 – Peace River
Area M – Zone BC28 – Northern Rockies

A financial bid presented using a format other than the Financial Evaluation Tables B.1 through B.13 may be declared non-responsive and given no further consideration.

A financial bid addressing only a portion of the work listed in the Financial Evaluation Table for a zone will be declared non-responsive and given no further consideration.

4.1.3.2 Calculation of Evaluated Bid Price

- a. The evaluated total bid price is the sum of the firm prices for an individual zone. Refer to Financial Evaluation Tables B.1 through B.13 at Annex “B” – Basis of Payment for more details.

4.1.3.3 Evaluation of Price – Bid

The price of the bid will be evaluated in Canadian dollars, Applicable Taxes excluded, FOB destination, Canadian customs duties and excise taxes included.

4.2 Basis of Selection

4.2.1 Mandatory Technical Criteria

A bid must comply with the requirements of the bid solicitation and meet all mandatory technical evaluation criteria and mandatory financial evaluation criteria to be declared responsive. The responsive bid with the lowest evaluated bid price for each zone will be recommended for award of a contract.

4.2.2 Number of Contracts

Canada intends to award only one (1) contract per zone. A contract may combine several zones in the event the same bidder is recommended for award of a contract for multiple zones. Canada may award up to thirteen (13) contracts (one per zone).

PART 5 – CERTIFICATIONS AND ADDITIONAL INFORMATION

Bidders must provide the required certifications and additional information to be awarded a contract.

The certifications provided by Bidders to Canada are subject to verification by Canada at all times. Unless specified otherwise, Canada will declare a bid non-responsive, or will declare a contractor in default if any certification made by the Bidder is found to be untrue, whether made knowingly or unknowingly, during the bid evaluation period or during the contract period.

The Contracting Authority will have the right to ask for additional information to verify the Bidder's certifications. Failure to comply and to cooperate with any request or requirement imposed by the Contracting Authority will render the bid non-responsive or constitute a default under the Contract.

5.1 Certifications Required with the Bid

Bidders must submit the following duly completed certifications as part of their bid.

5.1.1 Integrity Provisions - Declaration of Convicted Offences

In accordance with the Integrity Provisions of the Standard Instructions, all bidders must provide with their bid, **if applicable**, the Integrity declaration form available on the [Forms for the Integrity Regime](http://www.tpsgc-pwgsc.gc.ca/ci-if/declaration-eng.html) website (<http://www.tpsgc-pwgsc.gc.ca/ci-if/declaration-eng.html>), to be given further consideration in the procurement process.

5.2 Certifications Precedent to Contract Award

The certifications and additional information listed below should be submitted with the bid but may be submitted afterwards. If any of these required certifications or additional information is not completed and submitted as requested, the Contracting Authority will inform the Bidder of a time frame within which to provide the information. Failure to provide the certifications or the additional information listed below within the time frame specified will render the bid non-responsive.

5.2.1 Integrity Provisions – Required Documentation

In accordance with the section titled Information to be provided when bidding, contracting or entering into a real property agreement of the [Ineligibility and Suspension Policy](http://www.tpsgc-pwgsc.gc.ca/ci-if/politique-policy-eng.html) (<http://www.tpsgc-pwgsc.gc.ca/ci-if/politique-policy-eng.html>), the Bidder must provide the required documentation, as applicable, to be given further consideration in the procurement process.

5.2.2 Federal Contractors Program for Employment Equity - Bid Certification

By submitting a bid, the Bidder certifies that the Bidder, and any of the Bidder's members if the Bidder is a Joint Venture, is not named on the Federal Contractors Program (FCP) for employment equity "FCP Limited Eligibility to Bid" list available at the bottom of the page of the [Employment and Social Development Canada \(ESDC\) - Labour's](https://www.canada.ca/en/employment-social-development/programs/employment-equity/federal-contractor-program.html#) website (<https://www.canada.ca/en/employment-social-development/programs/employment-equity/federal-contractor-program.html#>).

Canada will have the right to declare a bid non-responsive if the Bidder, or any member of the Bidder if the Bidder is a Joint Venture, appears on the "FCP Limited Eligibility to Bid list at the time of contract award.

PART 6 - RESULTING CONTRACT CLAUSES

The following clauses and conditions apply to and form part of any contract resulting from the bid solicitation.

6.1 Statement of Work

The Contractor must perform the Work in accordance with the Statement of Work at Annex "A".

6.1.2 Technical Changes, Substitutions and Alternatives

Any technical changes, equivalent products and alternatives proposed by the Contractor must be evaluated for acceptance by the Project Authority. Any equivalent products and alternatives must be equivalent in form, fit, function and performance. Equivalent products and alternatives that are offered as equivalent will only be acceptable once they are approved by the Technical Authority as an equivalent. A contract amendment or a completed Design Change/Deviation form will be issued.

Should the Project Authority not accept the equivalent product or the alternative and the Contractor is unable to meet the technical requirement, Canada may terminate the contract for default in accordance with the general conditions stated in the contract.

6.2 Standard Clauses and Conditions

All clauses and conditions identified in the Contract by number, date and title are set out in the [Standard Acquisition Clauses and Conditions Manual](https://buyandsell.gc.ca/policy-and-guidelines/standard-acquisition-clauses-and-conditions-manual) (https://buyandsell.gc.ca/policy-and-guidelines/standard-acquisition-clauses-and-conditions-manual) issued by Public Works and Government Services Canada.

6.2.1 General Conditions

2010C 15 (2008-05-12) Compliance with applicable laws

1. The Contractor must comply with all laws applicable to the performance of the Contract. The Contractor must provide evidence of compliance with such laws to Canada at such times as Canada may reasonably request.
2. The Contractor must obtain and maintain at its own cost all permits, licenses, regulatory approvals and certificates required to perform the Work. If requested by the Contracting Authority, the Contractor must provide a copy of any required permit, license, regulatory approvals or certificate to Canada.

[2010C](#) (2021-12-02), General Conditions – Services (medium complexity), apply to and form part of the Contract.

[2010A](#) (2021-12-02) General Conditions – Goods (medium complexity) apply to and form part of the Contract.

6.3 Security Requirements

6.3.1 There is no security requirement applicable to the Contract.

6.4 Term of Contract

6.4.1 Period of the Contract

The period of the Contract is from date of contract award to March 31, 2023

6.4.2 Delivery Date

All the deliverables must be received on or before March 31, 2023.

6.4.3 Delivery Points

Delivery of the requirement will be made to delivery points specified at Attachment 5 – List of Repairs and Cemeteries.

6.5 Authorities

6.5.1 Contracting Authority

The Contracting Authority for the Contract is:

Name: Sine MacAdam
Title: Procurement Contracting Officer
Veterans Affairs Canada
Telephone: (902) 626-5288
E-mail address: sine.macadam@veterans.gc.ca

The Contracting Authority is responsible for the management of the Contract and any changes to the Contract must be authorized in writing by the Contracting Authority. The Contractor must not perform work in excess of or outside the scope of the Contract based on verbal or written requests or instructions from anybody other than the Contracting Authority.

6.5.2 Project Authority

The Project Authority for the Contract is: [\(to be inserted at Contract Award\)](#)

Name: _____
Title: _____

Telephone: ____-____-_____
Facsimile: ____-____-_____
E-mail address: _____

The Project Authority is the representative of the department or agency for whom the Work is being carried out under the Contract and is responsible for all matters concerning the technical content of the Work under the Contract. Technical matters may be discussed with the Project Authority; however, the Project Authority has no authority to authorize changes to the scope of the Work. Changes to the scope of the Work can only be made through a contract amendment issued by the Contracting Authority.

6.5.3 Contractor's Representative

| Bidder is to complete information below and submit with their bid: | |
|--------------------------------------------------------------------|--|
| Name | |
| Title | |
| Organization | |
| Procurement Business Number (PBN) | |
| Address | |

| | |
|-----------------------|--|
| Telephone No. | |
| E-mail Address | |

6.6 Proactive Disclosure of Contracts with Former Public Servants

By providing information on its status, with respect to being a former public servant in receipt of a Public Service Superannuation Act (PSSA) pension, the Contractor has agreed that this information will be reported on departmental websites as part of the published proactive disclosure reports, in accordance with Contracting Policy Notice: 2019-01 of the Treasury Board Secretariat of Canada.

6.7 Payment

6.7.1 Basis of Payment

In consideration of the Contractor satisfactorily completing its obligations under the Contract, the Contractor will be paid, as specified in Annex "B" – Basis of Payment up to a total cost of (\$ to be inserted at Contract Award). Customs duties are included and Applicable Taxes are extra.

Under any resulting contract, Canada will not accept the travel and living expenses that may need to be incurred by the contractor for any relocation of resources required to satisfy its contractual obligations.

6.7.2 Limitation of Price

Canada will not pay the Contractor for any design changes, modifications or interpretations of the Work unless approved, in writing, by the Contracting Authority before their incorporation into the Work.

6.7.3 Payment – Multiple Payment

Canada will pay the Contractor upon completion and delivery of units in accordance with the payment provisions of the Contract if:

- a. an accurate and complete invoice and any other documents required by the Contract have been submitted in accordance with the invoicing instructions provided in the Contract;
- b. all such documents have been verified by Canada;
- c. the Work delivered has been accepted by Canada.

6.7.4 Electronic Payment of Invoices – Contract

The Contractor accepts to be paid using any of the following Electronic Payment Instrument(s):

- a. Direct Deposit (Domestic and International);

6.7.5 Discretionary Audit

C0705C (2010-01-11) Discretionary Audit

6.8 Invoicing Instructions

1. The Contractor must submit all invoices in accordance with the section entitled "Invoice Submission" in the general conditions. Invoices cannot be submitted until all the work identified in the invoice is completed.

Each invoice must be supported by:

- a. A copy of any documents as specified in the Contract.

2. Invoices must be distributed as follows:
 - a. The original must be forwarded to the address shown on page 1 of the Contract for certification and payment.

6.9 Certifications and Additional Information

6.9.1 Compliance

Unless specified otherwise, the continuous compliance with the certifications provided by the Contractor in its bid or precedent to contract award, and the ongoing cooperation in providing additional information are conditions of the Contract and failure to comply will constitute the Contractor in default. Certifications are subject to verification by Canada during the entire period of the Contract.

6.9.2 Applicable Laws

The Contract must be interpreted and governed, and the relations between the parties determined, by the laws in force in British Columbia.

6.10 Priority of Documents

If there is a discrepancy between the wording of any documents that appear on the list, the wording of the document that first appears on the list has priority over the wording of any document that subsequently appears on the list.

- (a) the Articles of Agreement;
- (b) the general conditions [2010C](#) (2021-12-02) General Conditions – Services (medium complexity);
- (c) the general conditions [2010A](#) (2021-12-02) General Conditions – Goods (medium complexity);
- (d) Annex A, Statement of Work;
- (e) Annex B, Basis of Payment;
- (f) the Contractor's bid dated _____, (*insert date of bid*) (*If the bid was clarified or amended, insert at the time of contract award:*), as clarified on _____ " **or** ", as amended on _____ " *and insert date(s) of clarification(s) or amendment(s)*).

6.11 Insurance

The Contractor is responsible for deciding if insurance coverage is necessary to fulfill its obligation under the Contract and to ensure compliance with any applicable law. Any insurance acquired or maintained by the Contractor is at its own expense and for its own benefit and protection. It does not release the Contractor from or reduce its liability under the Contract.

6.12 Site Regulations

The Contractor must comply with all regulations, instructions and directives in force on the site where the Work is performed.

6.13 Dispute Resolution

- (a) The parties agree to maintain open and honest communication about the Work throughout and after the performance of the contract.
- (b) The parties agree to consult and co-operate with each other in the furtherance of the contract and promptly notify the other party or parties and attempt to resolve problems or differences that may arise.
- (c) If the parties cannot resolve a dispute through consultation and cooperation, the parties agree to consult a neutral third party offering alternative dispute resolution services to attempt to address the dispute.

- (d) Options of alternative dispute resolution services can be found on Canada's Buy and Sell website under the heading "[Dispute Resolution](#)".

6.14 Office of the Procurement Ombudsman

6.14.1 Dispute Resolution

The Parties agree to make every reasonable effort, in good faith, to settle amicably all disputes or claims relating to the Contract, through negotiations between the Parties' representatives authorized to settle. If the Parties do not reach a settlement within 25 working days after the dispute was initially raised to the other party in writing, either Party may contact the OPO to request dispute resolution/mediation services. The OPO may be contacted by e-mail at boa.opo@boa-opo.gc.ca, by telephone at 1-866-734-5169, or by web at www.opo-boa.gc.ca. For more information on the OPO's services, please see the [Procurement Ombudsman Regulations](#) or visit the [Office of the Procurement Ombudsman website](#).

6.14.2 Contract Administration

The OPO was established by the Government of Canada to provide an impartial, independent venue for Canadian bidders to raise complaints regarding the administration of certain federal contracts, regardless of dollar value. If you have concerns regarding the administration of a federal contract, you may contact the OPO by e-mail at boa.opo@boa-opo.gc.ca, by telephone at 1-866-734-5169, or by web at www.opo-boa.gc.ca. For more information on the OPO's services, please see the [Procurement Ombudsman Regulations](#) or visit the [Office of the Procurement Ombudsman website](#).

Annex A Statement of Work

Repairs to Veterans' Grave Markers – British Columbia

Background

Veterans Affairs Canada (VAC) is responsible for the care and maintenance of more than 220,000 Veterans' grave markers across Canada. The work to maintain these markers includes cleaning, aligning, installing new foundations and replacing broken and illegible markers. Landscaping on the gravesites and removal of vegetation from around the markers may also be required.

Location of Work

VAC has identified a number of repairs to Veterans' grave markers, located in cemeteries in the province of British Columbia, to be completed in 2022 (see attached *Table of Repairs*).

Zones

Area A – Zone BC04 – Kootenay Boundary
Area B – Zone BC07 – Greater Vancouver
Area C – Zone BC10 – Port Alberni/Tofino
Area D – Zone BC15 – Thompson/Nicola
Area E – Zone BC17 – North Okanagan
Area F – Zone BC19 - Cariboo
Area G – Zone BC20 – Mount Waddington
Area H – Zone BC22 – Skeena/Haida Gwaii
Area I – Zone BC23 – Kitimat/Stikine
Area J – Zone BC24 – Bulkley/Nechako
Area K – Zone BC25 – Fraser/Fort George
Area L – Zone BC26 – Peace River
Area M – Zone BC28 – Northern Rockies

Contracting Requirements

1. The Contractor must provide all labour, materials and equipment necessary for the supply, delivery and installation of deliverables as listed in the attached *Table of Repairs*.
2. The Contractor must complete all repairs in accordance with specifications contained in Section 4.0 and Section 5.0 of Veterans Affairs Canada's *National Technical Maintenance Manual* (see attached).
3. The Contractor must provide all labour, materials and equipment required for the removal and proper disposal of all debris associated with the work. If an existing marker is replaced by a new marker, the existing marker and all of the inscription must be disposed of in a dignified manner.
4. The contractor must destroy and dispose of an existing marker in the case of its replacement, and ensure there is no remaining inscription information visible.
5. The Contractor must complete any required landscaping, including seeding or re-sodding, to ensure that gravesites are returned to their original state.
6. The Contractor must provide templates of all new markers to the VAC Project Authority for approval **prior** to fabrication/engraving.
7. The Contractor must send a photo of each repaired and newly installed markers (if applicable) to the VAC Project Authority by way of a photo folder on a cloud storage website (i.e. file transfer

site, GoogleDrive, drop-box, etc.). Any photos not taken in accordance with the *Photo Guidelines* (see attached) must be re-done at the expense of the Contractor. There is no requirement for the Contractor to take photos of the markers prior to completing the repairs.

8. The Contractor and workers must conduct themselves as professionals and comply with all terms and conditions of the cemetery, including hours of operation. If there is a funeral or church service within the immediate vicinity, the Contractor must cease work until the end of the service. The work area must be left in a tidy state at the end of each day.
9. Should the Contractor be required to contact cemeteries prior to starting any work, the VAC Project Authority will provide the Contractor with contact information for the cemeteries once the contract is awarded. Failure to contact the cemeteries as required may result in refusal of entry.
10. The Contractors, their personnel and subcontractors must adhere to the health and safety plans established for the site, in addition to any laws in effect in the jurisdiction where the work is being performed.

Additional Contracting Information

1. When the contract is awarded, the VAC Project Authority will provide the Contractor with a detailed list of markers requiring repair, including the name and date of death on each marker, the type of repairs required, GPS coordinates (if available), and inscription information for any new markers (if required).

Ownership and Control

1. All information (personal or otherwise) which is used, processed, handled, stored, and recorded by the Contractor for the purposes of fulfilling the requirements of the Contract, regardless of the format, medium, and physical characteristics, remains under the ownership and control of VAC.
2. All applicable Federal legislations apply under all circumstances, even when such information is in the sole custody of the Contractor.
3. In accepting this contract, the Contractor acknowledges that VAC maintains ownership and control over all personal information and any other information that is collected, created, captured, received, used, processed, handled, stored, and recorded by the Contractor when fulfilling the requirements outlined in the Contract.
4. Upon delivery of the final requirements of the contract, the Contractor will ensure that all information referenced above is returned to the VAC Project Authority.

Security Requirements

No security requirements are necessary for this contract.

Attachments

- Attachment 1 National Technical Maintenance Manual, Section 4
- Attachment 2 National Technical Maintenance Manual, Section 5
- Attachment 3 Pinning instructions
- Attachment 4 Specifications for taking photos of repaired/new markers
- Attachment 5 List of Repairs and Cemeteries

Attachment 1

National Technical Maintenance Manual, Section 4

4.0 STANDARDS FOR THE INSTALLATION OF GRAVE MARKERS

4.0.2 Replacement of Veteran Grave Markers

When replacing veteran grave markers that are the responsibility of Canada:

- replace the standardized markers with markers that replicate the originals in conjunction with the grave marker specifications identified in this section.
- replace non-standardized markers with markers that replicate as closely as possible, the original. Replacement is a last resort and should only be considered in situations where corrective conservation efforts will not save the grave marker.

When replacing a Victoria Cross grave marker the inscription order is as follows:

- Top - maple leaf, official military crest or religious symbol;
- 1st line - Name;
- 2nd line - Rank;
- 3rd line - Unit and Conflict if space permits;
- 4th line - Date of Death;
- 5th line - Age;
- 6th line - Victoria Cross template; and
- Bottom - A few words/quote selected by family or regiment if space permits.

When replacing a marker that has a Maple Leaf on it, replace it with the copyrighted Commonwealth War Graves Commission Maple Leaf.

4.1 Markers: Form and Size

4.1.1 Veteran's Standard Upright Granite Marker

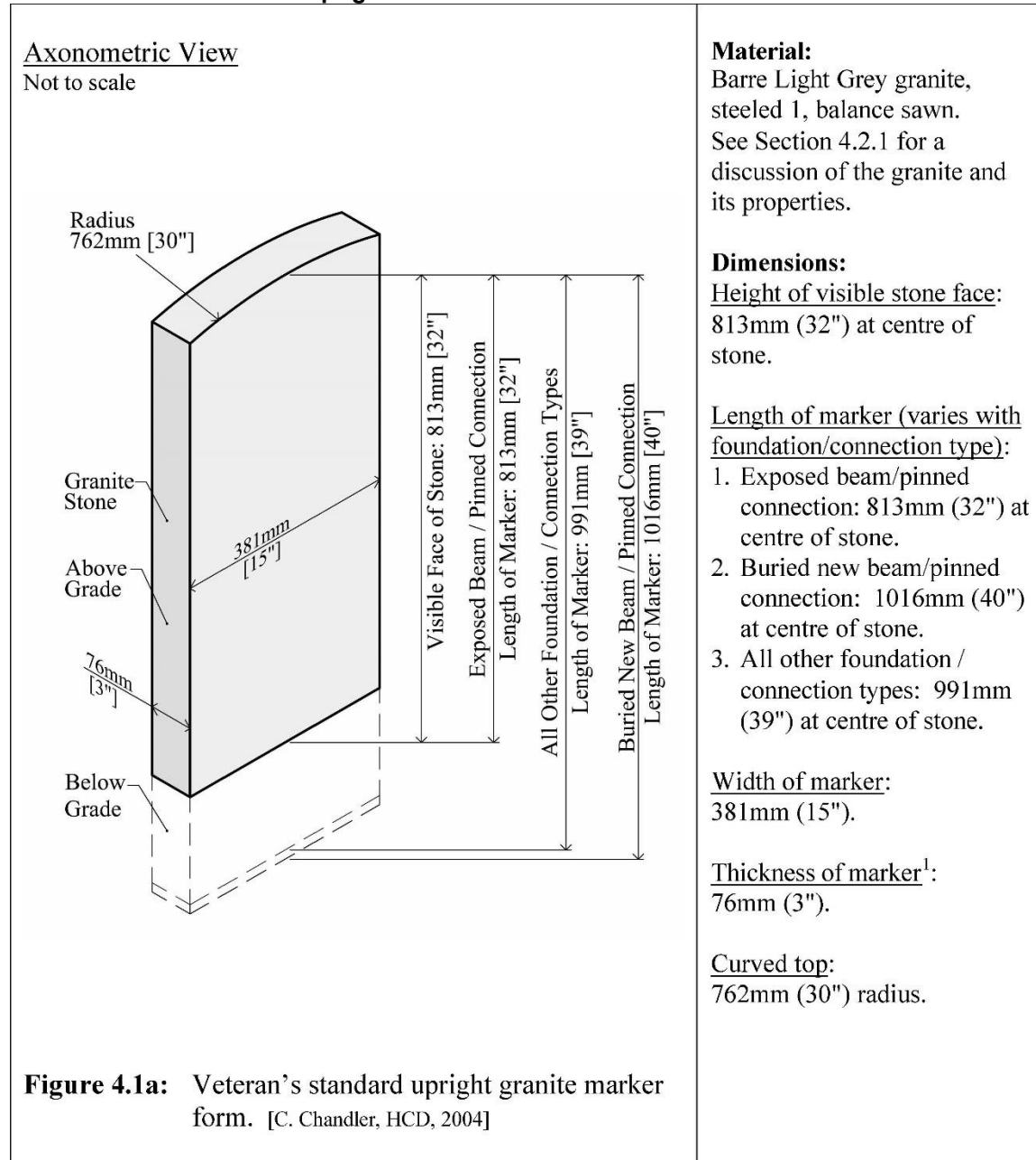

Note – see pages 9 and 10 for specifications on length of marker when using the Commonwealth War Graves Commission (CWGC) pocket foundation.

4.1.2 Veteran's Standard Flat Granite Marker

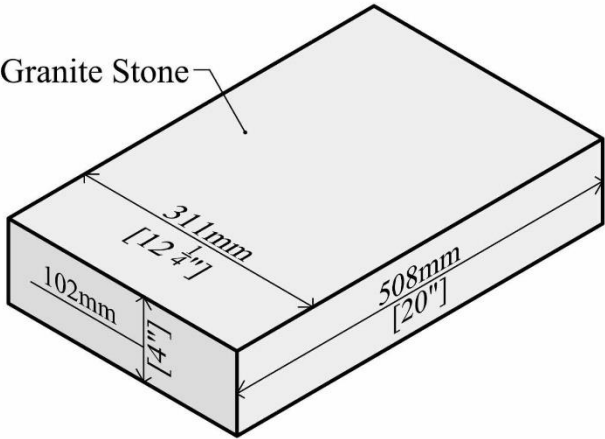
| | |
|------------------------------------------------------------------------------------------------------------------------------------------------------------------------------------------------------------------------------------|--------------------------------------------------------------------------------------------------------------------------------------------------------------------------------------------------------------------------------------|
| <p><u>Axonometric View</u> Not to scale</p>  <p>Figure 4.1b: Veteran's standard flat granite marker form. [C. Chandler, HCD, 2004]</p> | <p>Material: Barre Light Grey granite, steeled 1, balance sawn.</p> <p>See Section 4.2.1 for a discussion of the granite and its properties.</p> <p>Dimensions: 508 x 311 x 102mm (20" x 12 1/4" x 4")</p> |
|------------------------------------------------------------------------------------------------------------------------------------------------------------------------------------------------------------------------------------|--------------------------------------------------------------------------------------------------------------------------------------------------------------------------------------------------------------------------------------|

4.2 Markers: Materials and Alignment

4.2.1 Granite and Its Properties

The standard granite type for new VAC grave markers is Barre Light Grey. Barre Light Grey granite is the VAC and LPF name for Barre Gray granite that is supplied under a registered trademark by Rock of Ages Corporation, P.O. Box 482, Barre Vermont 05641, USA.

The mechanical properties of Barre Gray, obtained from Rock of Ages, are noted in the table below.

| Table 4.2a Mechanical Properties for Barre Gray Granite | | |
|----------------------------------------------------------------|----------------------------|----------------|
| ASTM Test | Mechanical property | Average |
| ASTM C97-96 <i>Absorption and Bulk Specific Gravity</i> | Absorption | .206% |
| | Bulk Specific Gravity | 166 lbs/ft3 |
| ASTM C99-87 <i>Modulus of Rupture</i> | Perpendicular dry | 2909 psi |
| | Perpendicular wet | 2621 psi |
| | Parallel dry | 2142 psi |
| | Parallel wet | 1900 psi |
| ASTM C170-90 <i>Compressive Strength</i> | Perpendicular dry | 29388 psi |
| | Perpendicular wet | 25000 psi |
| | Parallel dry | 23899 psi |
| | Parallel wet | 16293 psi |
| ASTM C880-98 <i>Flexural Strength</i> | Perpendicular dry | 2769 psi |
| | Perpendicular wet | 2437 psi |
| | Parallel dry | 1917 psi |

Parallel wet

1567 psi

4.2.3 Marker Alignment

Marker alignment refers to the relationship between individual grave markers within a grouping of markers. It is suggested that VAC follow an adaptation of the criteria developed by the CWGC in the matter of alignment. During installation every effort should be made to ensure that all markers are plumb. Upright markers should show the standard 81.3 cm (32") height of face above ground level for buried foundations, and the same height above their foundations for exposed foundations. However, the criterion for acceptance *"is that the group of markers should conform reasonably with each other, and that seen from the face or the three-quarter face, they should not appear unsightly to the practiced eye"*. (CWGC, 1999, para. 945)



Figure 4.2a: An example of a well aligned group of upright markers. [D. Stephenson, HCD, 2003]

4.3 Inscriptions: Lettering Properties and Content

4.3.1 Inscription Format for Veterans' Standard Upright Markers

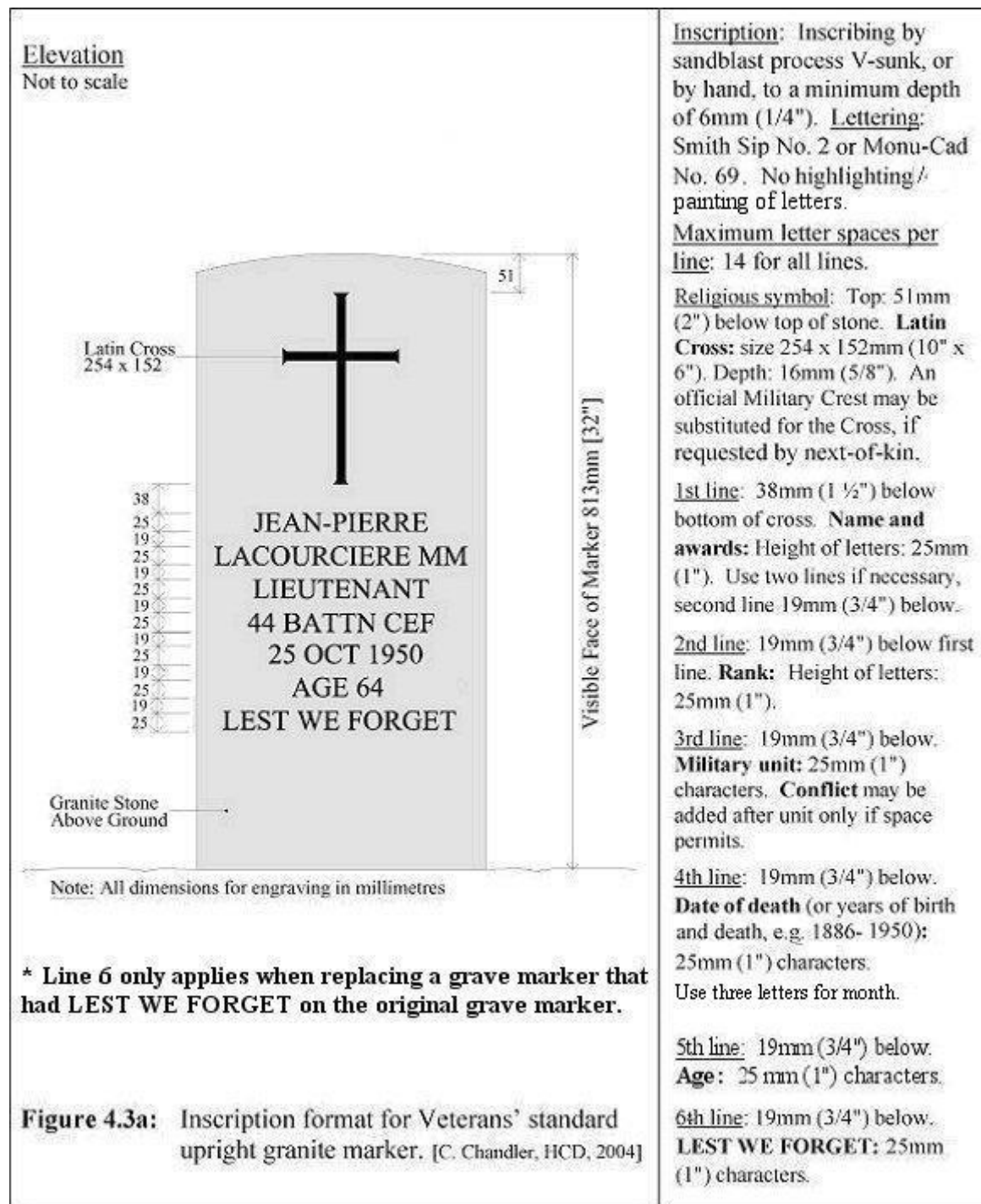

4.3.2 Inscription Format for Veterans' Standard Flat Granite Marker

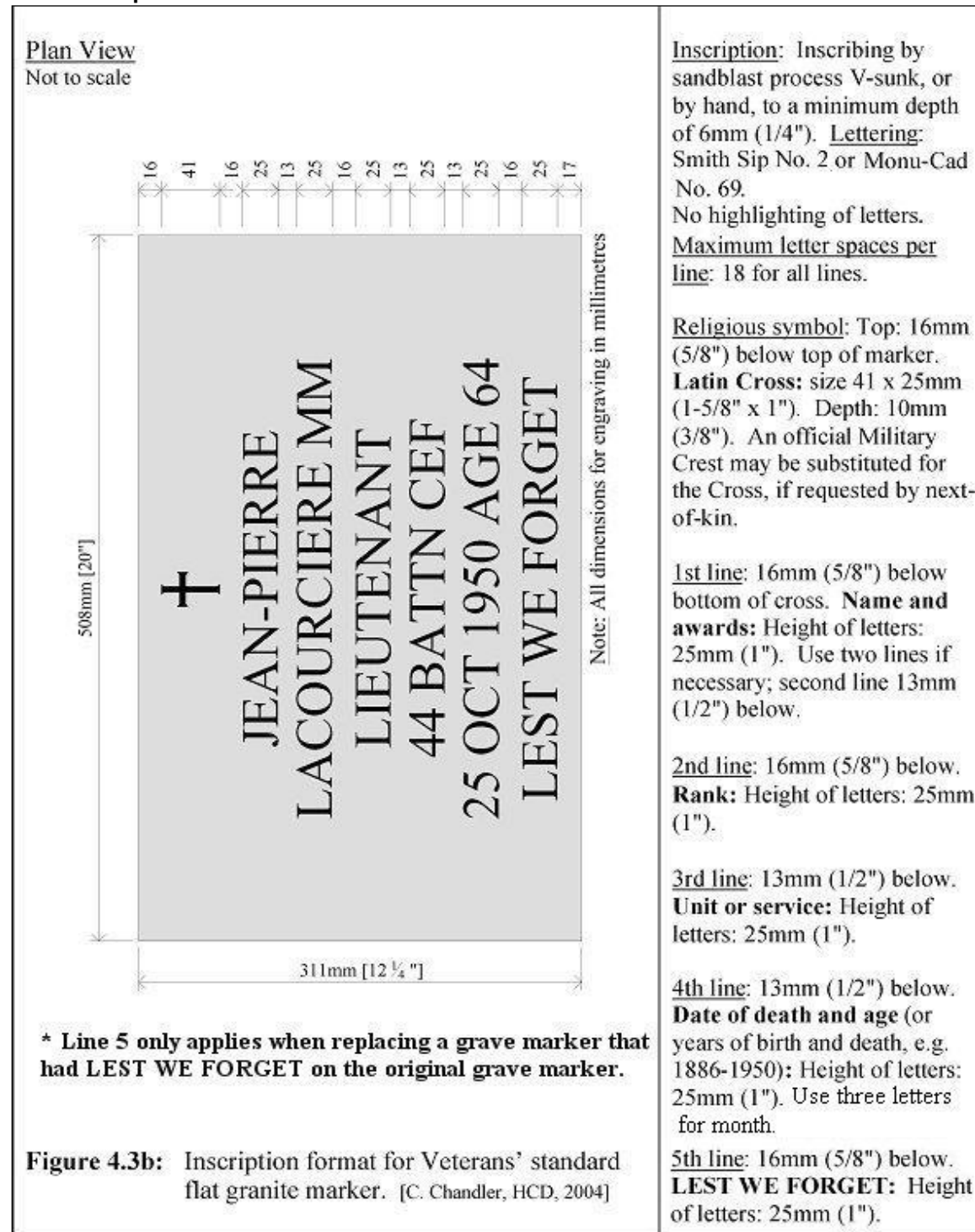

Foundation Types

Single marker foundation pads are appropriate in instances where the marker is isolated from other VAC markers. In this type of foundation, a reinforced concrete pad, solid granite block, or a compacted bed of granular fill spreads the weight of the marker over the soil and provides resistance against overturning of upright markers.

Emplacement Method

Marker foundations can be buried or exposed, and the decision to bury or expose should be based on a consideration of several factors, including:

- original design intent for the cemetery landscape,
- evolution of the site or previous practice at the cemetery,
- topography of the cemetery, and
- type and number of markers.

In evaluating the suitability of an exposed foundation, consideration should be given to the fact that exposing or raising the foundation above the grave surface has the benefit of reducing the risk of accidental damage to the markers from impacts with maintenance equipment as cutting the turfgrass right against the marker is eliminated. This can also reduce the time spent on mowing, and the need to water the turfgrass during dry periods.

Single Foundation Pads for Upright Granite Markers

The preferred foundation for single upright markers is the Commonwealth War Graves Commission (CWGC) in pocket foundation with an exposed emplacement (see page 9 and 10).

Where it is not possible to use the CWGC pocket foundation (i.e. due to space limitations, cemetery regulations or when repairing broken markers where the length of the marker is not sufficient for a pocket foundation), please contact VAC for direction.

Information on pinned connections is provided in this manual for reference when repairing markers with pinned connections.

Commonwealth War Graves Commission Foundation (Note: This is different than an LPF/VAC foundation)

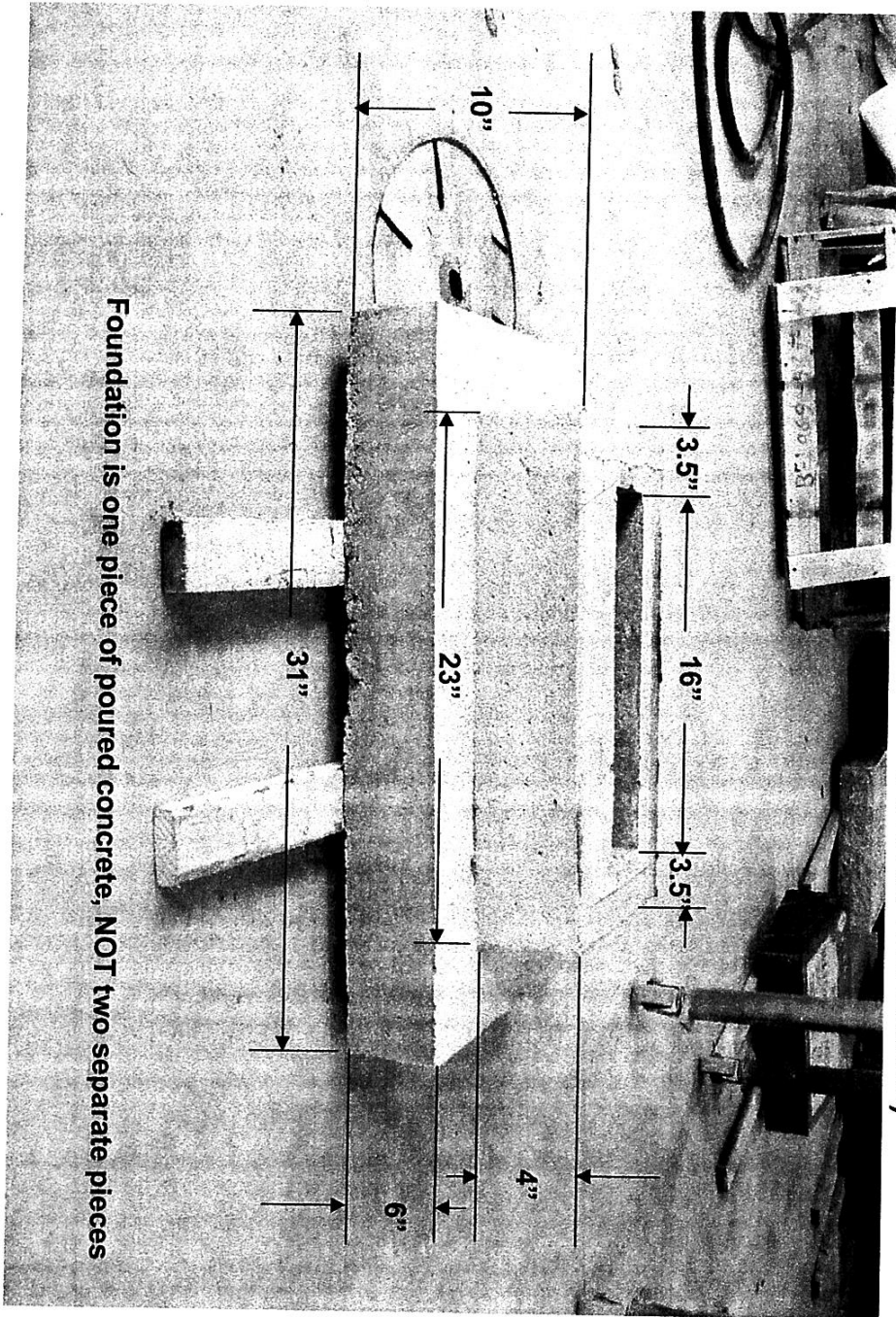

Commonwealth War Graves Commission Foundation (Note: This is different than an LPF/VAC foundation)

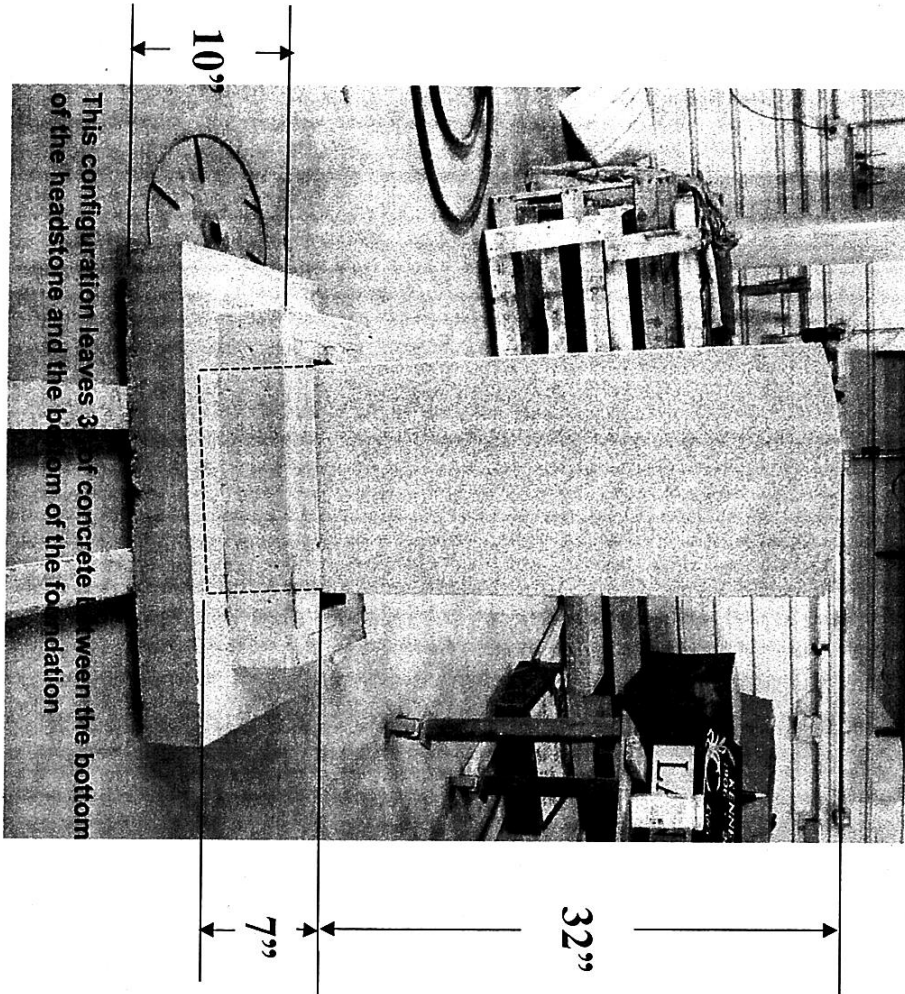

Exposed Emplacement

Not to scale

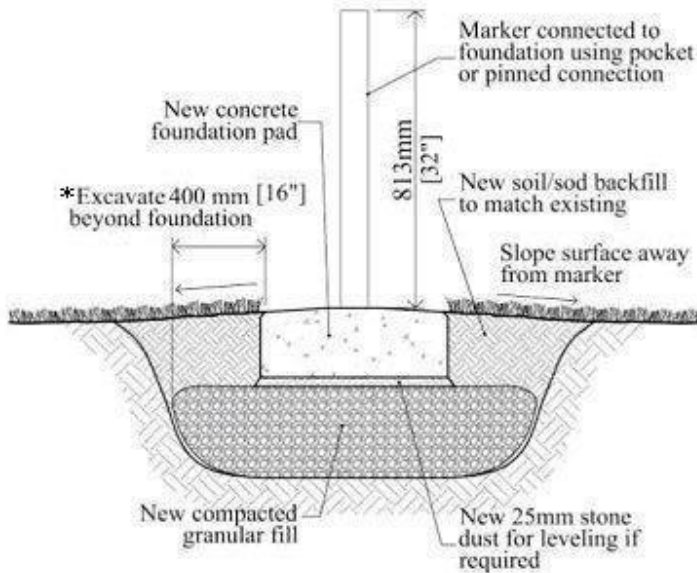

Buried Emplacement

Not to scale

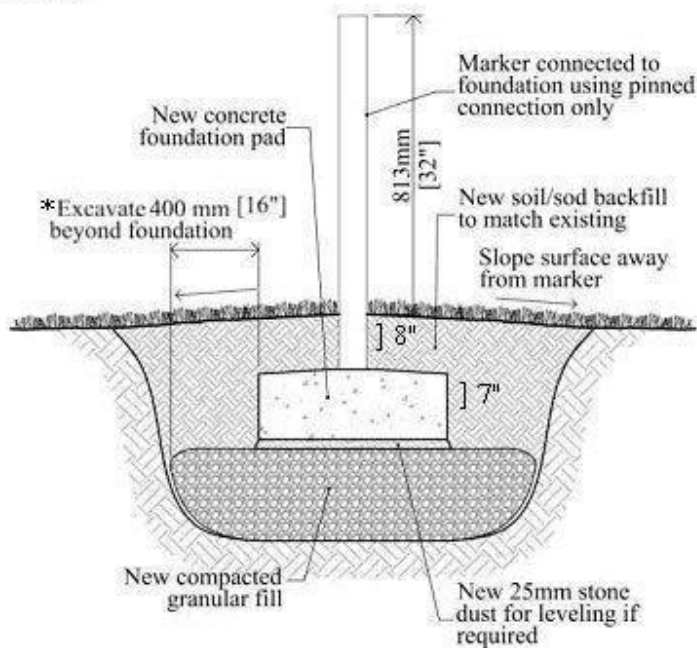

Figure 4.4a (i): Single foundation for upright marker
[C. Chandler, HCD, 2004].

Materials for Installation:

Reinforced concrete foundation pad. Refer to drawings 4.4a(ii) and (iii) for pad construction details.

New granular fill. For depth of new fill and compaction requirements refer to Section 4.4.2.

Wrap new granular fill in geotextile fabric, overlap joints 200mm minimum.

Use limestone screenings for stone dust.

Re-use existing sod or grave surface if suitable, otherwise provide new to match existing.

* Width of excavation for marker installation may be reduced to a minimum of 100 mm (4") on either side of the marker to avoid disruption to adjacent graves and to stay within grave boundaries.

**For Buried Emplacement marker length is 1016 mm (40") or more if necessary.

Single Foundation Pads for Flat Granite Markers

Where the face of the flat marker is set flush with the grave surface, the marker is set on a bed of compacted granular fill only, with no intermediate granite block foundation pad. This installation is also suitable for instances where existing flat markers are being re-set.

Where a foundation is recommended: a solid granite block supported on a prepared base of new free draining granular fill. Figure 4.4b (i) below, details the foundation block's dimensions.

Figure 4.4b (ii) details the emplacement methods for both foundation types.

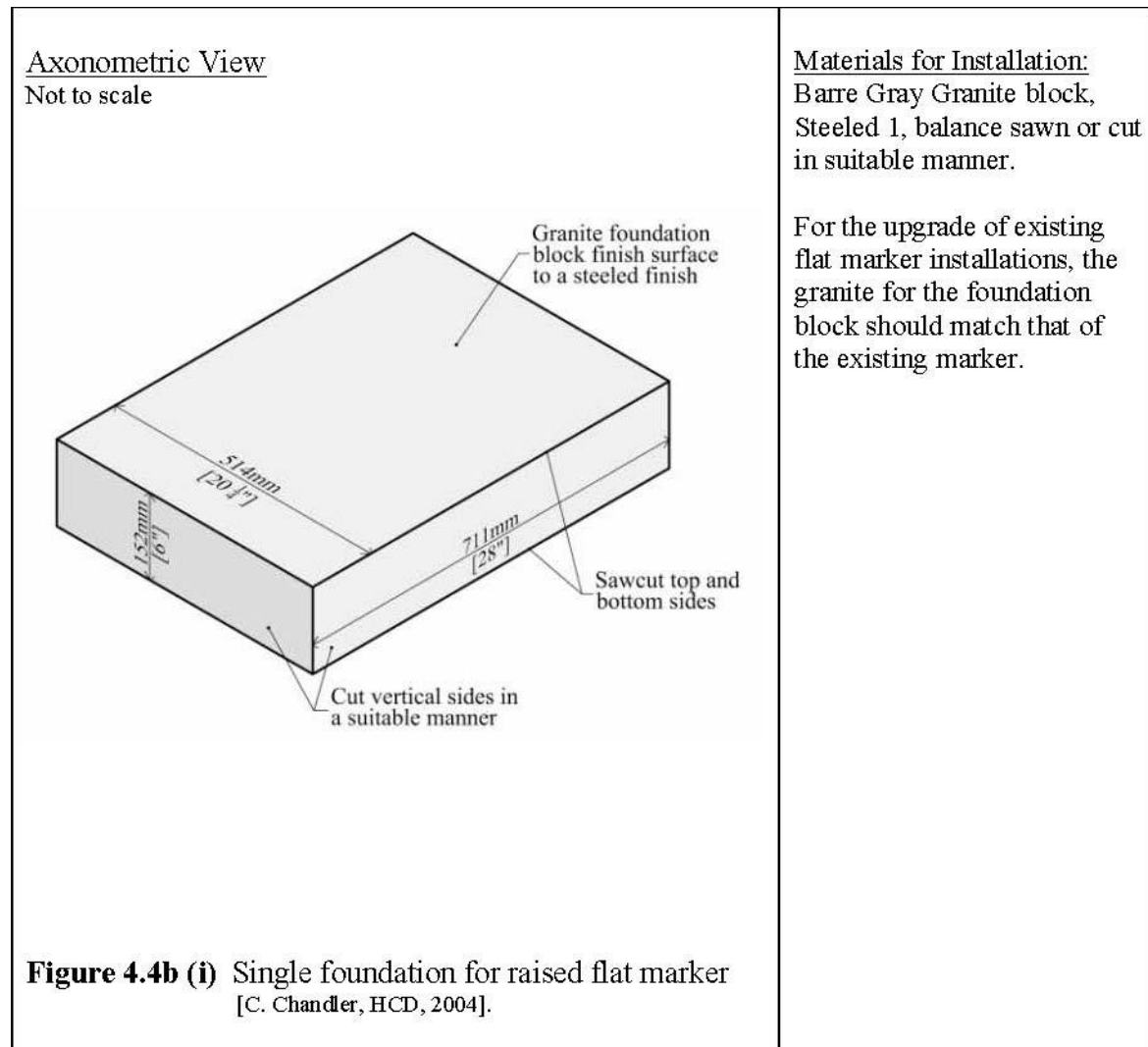
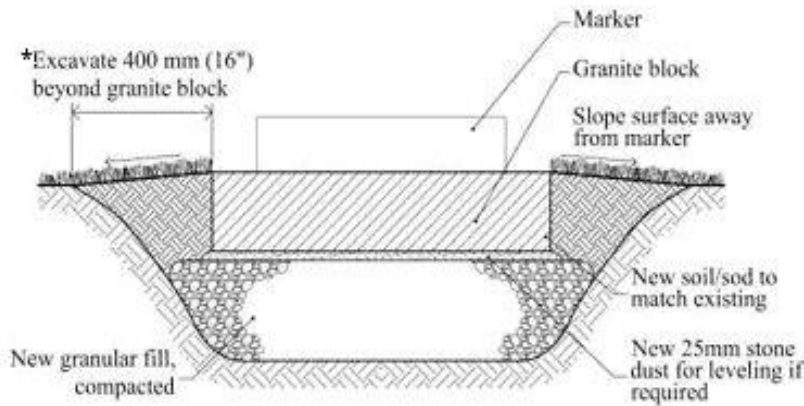

Figure 4.4b (i) Single foundation for raised flat marker
[C. Chandler, HCD, 2004].

Emplacement With Granite Block Foundation

Not to scale



Emplacement With Compacted Granular Fill Foundation

Not to scale

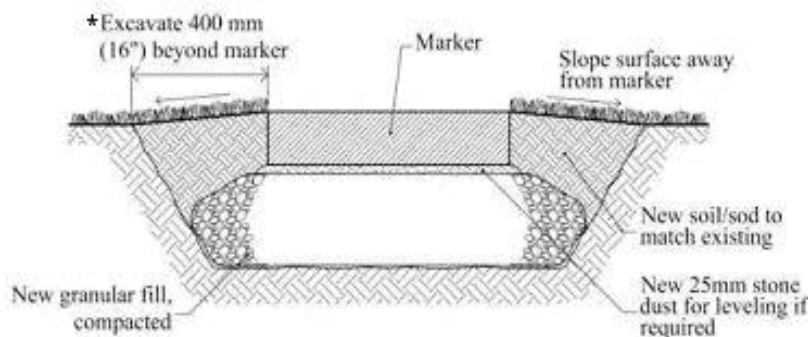

Figure 4.4b (ii) Single foundation for flat marker.
[C. Chandler, HCD, 2004].

Materials for Installation:

Barre Gray Granite block,
Steeled 1, balance sawn or cut
in suitable manner.

For the upgrade of existing
flat marker installations, the
granite for the foundation
block should match that of
the existing marker.

New granular fill. For depth
of new fill and compaction
requirements refer to Section
4.4.2.

Wrap new granular fill in
geotextile fabric, overlap
joints 200mm minimum.

Use limestone screenings for
stone dust.

Re-use existing sod or grave
surface if suitable, otherwise
provide new to match
existing.

* Width of excavation for
marker installation may be
reduced to a minimum of
100 mm (4") on either side
of the marker to avoid
disruption to adjacent graves
and to stay within grave
boundaries.

4.4.2 Foundation Materials

Concrete

The following concrete mix designs are appropriate for use with individual upright marker foundations.

Mass produced marker foundations using pre-cast techniques or pre-stressed beam designs may also require some deviation from these mixes to accommodate the different casting procedures followed in this type of manufacture. In such an instance, the pre-cast manufacturing company should use these mixes as a guideline in developing their mix design and the revised concrete mix should match these designs in durability and performance.

Any changes or revisions to the mix design and placement procedures and recommendations listed below should follow the CSA Standard A23.1, *Concrete Materials and Methods of Concrete Construction*, as a guideline.

Concrete standards for soils that are known to contain sulphates:

- minimum 35 MPa compressive strength;
- maximum water/cement ratio 0.4;
- use Type 20 Moderate Cement if water soluble sulphate (SO₄) in soil measures between 0.1 and 0.2 %, or sulphates in ground water measure between 150 and 1500 mg/litre;
- use Type 50 Sulphate Resistant Cement if water soluble sulphate (SO₄) in soil measures greater than 0.2 %, or sulphates in ground water measure greater than 1500 mg/litre;
- air entrainment 5% to 8%;
- slump 80mm.

Do not use calcium chloride or any admixture containing calcium chloride if the soil is known to contain sulphates.

Concrete standards for all other soils:

- minimum 35 MPa compressive strength;
- maximum water/cement ratio 0.4;
- use Type 10 Normal Cement;
- air entrainment 5% to 8%;
- slump 80mm.

In locations where drainage of the ground water is problematic and the number of freeze thaw cycles is high, using cements that contain Silica Fume can improve the durability of the concrete by reducing its permeability. Silica Fume cement has the designation SF added to the cement type, thus use Type 10 SF, Type 20 SF or Type 50 SF as appropriate for the sulphate conditions noted above.

Water used in mixing all concrete should be clear and free of oils, acids, alkalies, soluble chlorides, organic matter and sediment.

Fine aggregate for the concrete mix should consist of natural sand, manufactured sand or a combination of both. Coarse aggregate should be no larger than 38mm (1 ½") in diameter. All aggregate should be free of organic impurities.

Aggregates should not react with alkalies contained in the concrete. Premature deterioration of the concrete can occur as a result of a reaction between minerals in some rock types and the soluble alkaline components in the concrete. This is typically a regional problem resulting from the use of a particular rock as an aggregate. The source of the aggregate should be contacted to confirm that alkali-aggregate reaction is not a problem and that the aggregate conforms to the CSA Standard A23.1, *Concrete Materials and Methods of Concrete Construction*.

Concrete can be cast on site, or pre-cast off site. When feasible, the use of pre-cast concrete is preferred. Pre-cast concrete typically possesses superior finishing, weathering and strength characteristics over cast-in-place concrete, because of the greater ability to easily maintain uniform quality control and curing conditions in the controlled environment of a pre-cast facility. In situations where reasonably large quantities of foundations are being cast, pre-cast concrete should not involve a significant cost premium over cast in place concrete, in smaller batches, however, pre-cast concrete could

be more expensive than cast in place. Cast-in-place concrete can approach the quality and performance of pre-cast concrete if properly formed, mixed, placed and cured.

When casting concrete it must be placed within properly constructed wooden or metal forms as follows:

- When casting on site, the earthen sides of the excavated foundation pit should not be used as the form to shape the concrete mass.
- Formwork should be adequately fixed in place using wooden stakes and blocking to ensure that straight true lines are formed, and that the formwork does not shift or sag after the concrete has been placed.
- The formwork should be coated with a form release or parting agent that is nonstaining and non-volatile prior to casting the concrete. This will ensure easy removal of the formwork. If no release agent is used prior to casting, the formwork should be dampened with water prior to placing the concrete.
- Before casting the concrete, clean the form of any organic matter, ice or snow prior to placing the concrete.
- Careful stripping of formwork is required, so as not to accidentally chip or mar any surfaces of concrete that is intended to be exposed. Strip the formwork only after the concrete has gained sufficient strength, which usually takes 2 to 3 days.
- When casting concrete on site, wet the granular base prior to placing the concrete. Standing water should not be present.
- Use vibrators to ensure complete consolidation of the concrete and to prevent segregation, honeycombing or voids.
- When casting on site, do not bury or leave the wooden formwork in place after curing, always remove the formwork for re-use or disposal.
- Complete the placement of the concrete within 1-½ hours from the time water was first added to the dry material.
- When placing large amounts of concrete, take precautions to prevent cold joints forming between pours. Cold joints occur when concrete that is placed in the form is allowed to cure somewhat before the next pour of concrete is placed against it. The resulting "cold" joint between the two pours becomes a weak point in the casting.
- When casting on site, do not place concrete when the temperature of the soil or formwork is below 10 °C. Protect freshly cast concrete from freezing for a minimum of 7 days after placement. Use insulated tarps or plastic sheets covered with a thick layer of straw to contain the heat of the curing concrete and to protect the concrete from freezing. Ideally the concrete should not be cast if cold weather, below 5 °C to 10 °C, is forecast.
- Similarly, protect freshly cast concrete from high temperatures, direct sun, and high winds by covering the concrete with burlap and regularly wetting the burlap. Ensure the burlap is clean so as not to stain the concrete.

The exposed surfaces of concrete should be level and finished with a uniform brush finish.

Steel Reinforcement

Steel reinforcement should conform to CSA Standard A23.1, *Concrete Materials and Methods of Concrete Construction*. Reinforcement bars should be deformed bars. Welded wire fabric may also be used in some instance and should conform to CSA Standard G30.5, *Welded Steel Wire Fabric for Concrete Reinforcement*. Steel strands, tendons and cables may be used in pre-stressed concrete to fabricate multiple marker beam-on-grade and beam-on-pier type foundations, and should conform to CSA Standard G279, *Steel for Prestressed Concrete Tendons*.

The following are general recommendations for reinforcement:

- Reinforcement steel should be clean and free of mud, oil, and heavy rust deposits. Mild mill scale and surface corrosion on the reinforcing is acceptable.
- Reinforcement bars should be supported inside the formwork as required on pre-cast concrete block supports. The concrete blocks should be made of a concrete that is at least equal in quality to the concrete being placed for the footing. Do not use formed wire supports, broken bricks, or pieces of wood as supports for the reinforcement.
- Secure the reinforcement to the supports using plastic coated wire to prevent accidental slipping during placement of the concrete. Do not use plain un-coated wire.
- Reinforcement bars must always be provided with a minimum of 75mm (3") concrete cover on surfaces exposed to the soil.

Epoxy coated reinforcement bars can be used to increase the corrosion resistance of the steel, however, accidental cuts, scratches and nicks in the epoxy coating resulting from rough handling during delivery and installation can reduce the effectiveness of the coating and must be touched up with a brushed on epoxy. Similarly, the ends of the bars, where they have been cut, must also be field coated. Epoxy coated bars must be shop bent using proper tools and equipment so as not to shatter or crack the epoxy coating: bending the bars to too tight a curvature can damage the coating. Epoxy coated bars should never be field bent. Epoxy coated bars should meet the requirements of ASTM standard D3963, *Specification for Prefabricated Epoxy-Coated Reinforcing Steel Bars*.

A practical reinforcement alternative to steel or epoxy coated steel reinforcement is fibre-reinforced polymer reinforcement, in particular glass fibre reinforced polymer reinforcement (GFRP). This type of reinforcement does not corrode and is of particular benefit in beams where the 75mm concrete cover required for steel reinforcement is difficult to obtain. Also, based on testing by the University of Manitoba, GFRP is preferred for use as the dowels in the pinned connections used for upright markers, because of its strength, flexibility, and corrosion resistance.

Granite

Granite blocks used as foundation pads for flat and other form markers should be fabricated from Barre Gray Granite. When new blocks are being installed to support existing markers, the granite should match the granite of the existing marker.

The top and bottom sides of the granite blocks should be sawn to permit accurate seating of the block on the granular fill base and the marker on the block. The sides of the block may be sawn or cut in a suitable manner determined by the quarry or the local supplier. If the top of the granite base is intended to be exposed at the grave surface, it should be finished with neatly squared edges and a steeled finish.

Marker / Foundation Connections

Mortar mix for use with Commonwealth War Graves Commission in pocket foundations

Pinning is not required for in pocket foundations. The socket must have an opening/ space of a 3.5"x 16"x 7" to allow a dry base mortar Portland mix (one part Portland cement to three parts sand) to be compacted in layers. The minimum amount of water needed for workability should be added. Very well compacted as this reduces shrinkage of the mortar around the headstone, hence future spalling and the finish to be flush and smooth. **Caulking is not accepted.**

Epoxy Adhesive (for use with pinned connections)

Epoxy Adhesive is used with the pinned connection method to bond the stainless steel or glass fibre dowels to the concrete foundation and granite marker. The epoxy should come pre-packaged in two-part mixing tubes to ensure proper mixing proportions. The epoxy must be appropriate for use in holes cored with diamond coring equipment, and must have a low sensitivity to use in wet or oversized holes. The epoxy should have a reasonably long working time, also referred to as its gel time, of up to thirty minutes to permit adjustment to the alignment of the markers, and should be fully cured within twelve hours at normal temperatures (10 degree Celsius or above).

The epoxy adhesive should match or exceed the following specifications for performance:

| | |
|----------------------|-----------------------------------------------------------------------------------------------------------------------------------------------------|
| Standard | Type IV, grade III, class A, B, C except gel time as per ASTM C881 <i>Standard Specification for Epoxy-Resin Based Bonding Systems for Concrete</i> |
| Bond Strength | 12.4 MPa at 2 days per ASTM C882-91 <i>Standard Test Method for Bond Strength of Epoxy-Resin Systems Used With Concrete by Slant Shear</i> |
| Compressive Strength | 82.7 MPa as per ASTM D-695-96 <i>Standard Test Methods for Compressive Properties of Rigid Plastics</i> |
| Tensile Strength | 43.5 MPa at 7 days as per ASTM D638-97 <i>Standard Test Method for Tensile Properties of Plastics</i> |
| Elongation at break | 2.0% as per ASTM D-638-97 <i>Standard Test Method for Tensile Properties of Plastics</i> |
| Absorption | 0.06% as per ASTM D-570-95 <i>Standard Test Method for Water Absorption of Plastics</i> |

Epoxy mixing, placement, and curing procedure must follow the manufacturers' recommendations; however, the following general recommendations also apply:

- Use correct mixing nozzles and applicators, as recommended by the epoxy manufacturer.
- Clean holes with a brush and air prior to injecting epoxy. Cleaning dust from the holes is essential to the performance of the epoxy and most manufacturers supply air nozzles and hand pumps specifically designed to clean holes out.
- Twist the dowels while inserting them into the epoxy filled hole.
- After making adjustments for alignment, do not disturb the anchor or marker prior to completion of the full cure time.

Glass Fibre Reinforced Polymer (GFRP) Rod (for use with pinned connections)

Glass Fibre Reinforced Polymer (GFRP) rods are recommended for use as the dowels connecting the granite marker to the concrete foundation in the pinned connection method. The rods must be glass fibre reinforced polymer bars with a sandy coating on their surface to aid in bond development. GFRP rods must conform with the standards outlined in CAN/CSA-S806-02, *Design and Construction of Building Components with Fibre Reinforced Polymers*. Material specifications for the rods must match the following:

| | |
|-----------------------------------|------------------------------------------------|
| Bar diameter | 16mm (5/8") |
| Binding material | Modified vinyl ester, volume fraction 25% |
| Fibre reinforcement | Continuous E-glass fibres, volume fraction 75% |
| Ultimate Tensile Strength, Fu | 674 MPa |
| Tensile Modulus of Elasticity, Et | 42000 MPa |

Follow the manufacturer's recommendations for handling, storing, cutting and placing GFRP rods.

Stainless Steel Threaded Rod (for use with pinned connections)

Stainless Steel threaded rods are acceptable for use as the dowels connecting the granite marker to the concrete foundation in the pinned connection method, though GFRP rods are preferred. The rods must be AISI 316 stainless steel rods, threaded to aid in bond development. Material specifications for the rods must match the following:

| | |
|--------------|-------------|
| Bar diameter | 16mm (5/8") |
|--------------|-------------|

Follow the manufacturers recommendations for handling, storing, cutting and placing stainless steel rods.

Pinned connection method for upright markers

The pinned connection method uses two GFRP or stainless steel dowels to connect the granite marker to the concrete foundation. Epoxy adhesive bonds the dowels to the marker and the foundation. Holes, into which the dowels are epoxied, must be drilled into the base of the granite marker and top of the concrete foundation.

Some special order markers also require the marker to be fixed to the foundation base, and the pinned connection type should again be used in these situations. Another less common special order marker is one that involves the use of upright markers that are connected to exposed granite bases, which in turn sit on multiple marker beam type foundations. This emplacement method is used in some cemeteries when the marker is located in civilian areas, and cemetery regulations forbid attaching the markers to the foundations. These markers should use the pinned connection to connect the marker to its granite base. The following steps are required to complete the installation of a marker using the pinned connection method. Steps 2 and 3 can typically be completed at the memorial contractors workshop, as well as steps 4 and 5 for single marker foundations. The other steps are completed on site at the cemetery:

1. Cast and install the foundation pad or beam following the recommendations for new installations. Ensure that none of the steel reinforcement in the foundation passes through the middle of the foundation where the holes for the dowels will be core-drilled.
2. Using a template to ensure accuracy, core-drill holes in the bottom of the granite marker. Ensure the holes are straight into the marker and do not tilt towards one face of the marker. Use a diamond-coring bit sized slightly larger than the diameter of the dowel, and note that the sand coating on the GFRP dowels increases their actual diameter closer to 17.5 mm (11/16"). Core drill the holes 150 mm (6") deep, do not over-drill the depth. Clean the holes of all dust or excess water using oil free compressed air.
3. Inject epoxy into the holes and insert the dowel, twisting it as it is being pushed into the hole. Inject only enough epoxy to fill the hole when the dowel is completely inserted (the actual quantity will vary depending on the depth of the hole and will become more apparent after a few installations). Partially withdraw the dowel to check that full coverage with the epoxy has been achieved. Clean off any

epoxy that oozes from the hole taking care to keep it off of the faces of the marker. Allow the epoxy to fully cure before moving the marker.

4. Using a template to ensure accuracy, core-drill holes into the foundation pad or beam. Ensure the holes are plumb by using a bubble level or similar to check the angle of the drill while drilling. Use a 25mm (1") diameter diamond core drill. Drill the holes 150mm (6") deep, over-drill the depth of the hole slightly if necessary to ensure that the dowel does not bottom out when the marker is set on the foundation (measure the depth of the hole and compare with length of exposed dowel protruding from the marker). Clean the holes of all dust or excess water using oil free compressed air.
5. Fill holes in foundation one half to two thirds full of epoxy (the actual quantity will vary depending on the depth of the hole and will become more apparent after a few installations). Carefully and slowly lower the marker onto the foundation. After the marker is fully seated on the foundation, temporarily lift the marker several inches and check to see that the epoxy in the holes has filled the hole to the top. Add more epoxy as required to fill the hole when the marker is fully seated, and re-lower the marker.
6. Check marker alignment and use small wood shims to level and align the marker. Complete all adjustments within the gel time of the epoxy. Clean any epoxy that may have oozed out from beneath the marker if this is an exposed foundation emplacement. Use lacquer thinner to clean the epoxy.
7. Allow the epoxy to fully cure before removing shims and backfilling topsoil around marker.

Granular Fill

Granular fill used for drainage purposes beside and below the foundation pads and beams should be a granular material composed of inert, hard, durable crushed stone or gravel. The fill should be screened of fine particles and free of organic material, and clay and silt balls.

Two gradations of granular fill are required depending on the depth of the fill: base course and sub-base course. The base course and sub-base course material should fall within the gradations outlined in Table 4.4a, below and determined in accordance with ASTM C136 *Method for Sieve Analysis of Fine and Coarse Aggregates*.

| Table 4.4a | Recommended Gradation of Base Course and Sub-base Course Granular Fill | |
|------------|------------------------------------------------------------------------|----------------------------------------------|
| | Passing Standard Sieve | Gradation Limits (Percent passing by weight) |
| | | Base course granular |
| 75 mm | | 100 |
| 25 mm | 100 | 50-85 |
| 19 mm | 80-100 | |
| 9.5 mm | 50-100 | |
| 4.75 mm | 40-70 | |
| 2.36 mm | 25-50 | |

| | | |
|---------|-------|------|
| 1.18 mm | 15-35 | |
| 0.3 mm | 5-20 | |
| 0.15 mm | | 0-16 |
| 425 µm | 0-5 | |
| 75 µm | | 0-5 |

The thickness of the layers of granular material placed beneath the foundation will vary depending on the soil type present. Table 4.4b, below details the thickness of the fill and compaction recommendation for each common soil type.

The granular material should be placed in maximum 150mm (6") deep layers, and each layer should be compacted prior to the placement of subsequent layers. Layers compacted with vibrating plate compactors, or similar, should be compacted to 95% standard proctor density.

| Table 4.4b Recommended Thickness Of New Granular Fill By Soil Type | | |
|---------------------------------------------------------------------------------------------------------|--------------------------------------------------------------------------------------------------------------|---------------------------------------------------------------------------------------------------------------|
| Soil Type | Recommended Thickness of New Granular Fill | |
| | Single Marker Foundations | Multiple Marker Beam-on-Grade Foundations |
| Reasonably free draining coarse granular soil (i.e. gravely soil), including glacial till. | No new granular fill is required beyond that necessary for leveling purposes. | Minimum 100mm (4") base course compacted by vibrating plate or similar, for leveling purposes. |
| Reasonably free draining sandy soil with no ongoing soil movement problems. | Minimum 150mm (6") base course compacted by hand. | Minimum 200mm (8") base course compacted by vibrating plate or similar. |
| Organic soils (including peat and organic silts), clays, and fills with ongoing soil movement problems. | Minimum 250mm (10") compacted by vibrating plate or similar. Base course 4" thick, sub-base course 8" thick. | Minimum 400mm (16") compacted by vibrating plate or similar. Base course 4" thick, sub-base course 12" thick. |

Geotextile Filter Fabric

The granular fill should always be wrapped with a geotextile filter fabric to prevent it from becoming clogged with fine soil particles transported by water movements. The geotextile should be a non-woven synthetic fabric with a filtering opening size (FOS) of 75 to 150 micrometers. Any joints in the fabric should be overlapped by a minimum of 200mm (8").

Attachment 2

National Technical Maintenance Manual, Section 5

5.1 Marker Cleaning

Attempts at cleaning should always be carried out starting with the gentlest means possible and advancing to the next harshest method only if required. Cleaning methods should also always be first tested on a sample of the stain to determine their effectiveness and to identify whether they cause any unanticipated damage to the marker, its foundation, or the surrounding plantings.

Multiple stains can occur on a single marker or foundation. In such instances the cleaning approaches should again always begin with the gentlest method, and as the cleaning proceeds to the harsher methods for the more stubborn stains, the treated areas should be limited only to the remaining stained parts of the marker.

5.1.1 Simple Cleaning

The following are general guidelines that should be followed in any attempts at cleaning stains on granite or bronze markers:

- Wash and scrub markers and their foundations with clean water and a nylon brush.
- Do not undertake cleaning with water when freezing temperatures are expected. Ensure that there is sufficient time for the stone to dry before freezing will occur.
- Use clean water only. Test the water to determine if it contains impurities or minerals that could produce staining such as salts and iron. If necessary, filter the water or use a chelating or complexing agent such as ethylene diamine tetra-acetic acid (EDTA) to make metallic ions inactive. Specialist technical advice should be sought to help in interpreting the results of any testing, to determine the most effective filtering method, and/or to determine the most effective additive to use to address any water quality issues.
- Do not add detergents to the water.
- Soaking stains and adhered materials with water for a short time prior to cleaning can often help to soften and loosen the materials to improve the effectiveness of the cleaning.
- Do not use steel brushes or metal tools such as spatulas, knives, or screwdrivers.
- Do not use household cleaners with abrasives such as Vim, Spic and Span, Fantastic etc.
- Do not use household cleaners such as Clorox, Borax, Comet or any cleaners with sodium hydroxide (NaOH).
- Do not use abrasive pads such as Brillo, steel wool or ScotchBrite.
- Do not use biocides to kill off plants, such as lichen.
- Do not use rotary grinders or sanders.
- Do not use abrasive "sandblasting" techniques on granite or bronze markers.
- Do not use acids as additives to the water when cleaning bronze markers.

In general, acidic cleaners are not recommended because of the potential for damage to the marker

material, the environmental impact on nearby plants and soil, and the health concerns associated with their application and use.

5.1.2 Pressure Washing

If washing with a nylon brush and water does not produce an acceptable degree of removal, use pressure-washing techniques. Pressure washing is acceptable, provided:

- the maximum pressure is below 400 psi,
- a fan type tip with a minimum 15° spread is used, and
- the nozzle is held perpendicular to the surface at a distance between 18" and 30" from the surface.

Use extreme care with pressure washing so as not to damage or degrade the softer materials of mortar joints between the marker and concrete foundation and the concrete foundation itself. Care must also be exercised when pressure washing the inscriptions as the pressure of the water can break off fragile parts of the inscription.

Pressure washing is not acceptable for use on flat markers with lead filled inscriptions as the water pressure can lift and blow off the lead filling. This is particularly pertinent if any of the lead lettering is already missing.

Do not use acids or other additives when pressure washing. To minimize potential damage, pressure washing should only be used to loosen and soften any adhered organic material. Once this material becomes loose, it should be scrubbed off using a nylon brush and water.

The stains occurring on Veterans' grave markers can be from several sources. Although the general principles of cleaning outlined above still apply, some additional steps may also be necessary depending of the source on the stain.

Lichen

- Prior to washing, remove any loose lichen using a spatula made of wood, plastic, or rubber. Do not use metal spatulas.
- Lichens will return. The schedule for cleaning lichens should be determined based on the rate of growth of the lichens and their impact on the legibility and presentation of the markers. Lichens that have been present on the marker for long periods of time can produce very stubborn stains that cannot be satisfactorily cleaned using the simple methods described above. If the inscription is still illegible after cleaning using simple methods, contact VAC to determine if the stone should be replaced.
- Stains from tree sap, backsplash, and standing water
- Organic stains, which have been present on the marker for long periods of time, can become very stubborn and will resist the simple cleaning methods described above. If the inscription is still illegible after cleaning using simple methods, contact VAC to determine if the stone should be replaced.

Efflorescence

- Efflorescence is caused by moisture that contains salts moving through the stone and evaporating on the face of the stone, leaving salt deposits on the face. Improving drainage around the marker, to reduce moisture absorption, will reduce the severity of the efflorescence. Efflorescence could also indicate problems with the soil or the local water supply. Sub-efflorescence may be occurring where efflorescence is observed. Sub-efflorescence is salts that are deposited just beneath the surface of the stone and can produce expansive forces that can lead to blistering, shaling and deterioration of the surface.

- Brush and water and pressure washing techniques will remove the efflorescence powder off of the marker, however, the cause of the efflorescence, soluble salts, will remain in the stone and the efflorescence will usually return unless steps are taken to address the source of the moisture.
- For severe efflorescence, poultices may be necessary. Poultices are stiff paste-like mixtures that are applied directly over the affected area of the stone. Poultice materials such as Fullers earth, kaolinite, or diatomaceous earth are used to create the thick paste to which salts are drawn to during evaporation. Shredded paper or paper towels can also be used as the inert poultice material. The following is the basic process to follow with poultices:
 - Wet the affected area of the marker with water and apply the poultice mixture in a layer that is about 12 mm (1/2") thick and allow it to dry naturally.
 - Once dry (the poultice mass will have cracked and cupped up), carefully remove the poultice material. Ensure that the poultice material does not fall onto and get mixed into the soil as this can return the soluble salts to the soil where they can be transported back into the stone.
 - Wash the treated area with clean water and a nylon brush.

Rust staining

- Washing with a brush and water or with a pressure washer will typically not remove moderate or heavy rust stains. Cleaning rust stains usually requires the use of harsh chemicals and is generally beyond the scope of simple cleaning or regular maintenance. If the inscription is still illegible after cleaning using simple methods, contact VAC to determine if the stone should be replaced.
- A water supply that is contaminated with metallic ions can lead to rust staining that appears as a uniform discoloration of the entire marker. This type of staining rarely will result in an inability to read an inscription and should not require cleaning. Weathering and rainfall may eventually rinse this type of staining off. To reduce the tendency for this type of staining to occur, treat the water supply through filtering or the use of chelating or complexing agents, to remove the metallic ions.

Tire-tread marks

- Pressure washing should typically remove tire-tread marks. If the inscription is still illegible after pressure washing, contact VAC to determine if the stone should be replaced.

Paint and graffiti

- Contact VAC to report incidents of graffiti and for recommendations on cleaning.

Other stains

- Other specific stains encountered, and not mentioned above, may require more than the simple cleaning methods. If the inscription is still illegible after cleaning using simple methods, contact VAC who will to determine if the stone should be replaced or if more intensive environmentally challenging procedures are warranted.

Attachment 3

PINNING INSTRUCTIONS

Stainless steel dowels to connect the granite marker to the concrete foundation.

Three (3) Stainless steel dowels would be installed and the middle is to be off-centre. Epoxy adhesive bonds the dowels to the marker and the foundation. Holes, into which the dowels are epoxied, must be drilled into the base of the granite marker and top of the concrete foundation.

Caution: NO glue/epoxy is to be smothered along bottom of stone. This seals the stone at points and does not allow the wicking process to follow through the granite. Glue/epoxy is to be applied only on the dowels.



Ensure that none of the steel reinforcement in the foundation passes through the middle of the foundation where the holes for the dowels will be core-drilled.

- 1- Using a template to ensure accuracy, core-drill holes in the bottom of the granite marker. Ensure the holes are drilled parallel to the marker face. Use a diamond-coring bit sized slightly larger than the diameter of the dowel, and note that the sand coating on the dowels increases their actual diameter closer to 17.5 mm (11/16"). Core drill the holes 150 mm (6") deep, do not over-drill the depth. Clean the holes of all dust or excess water using oil-free compressed air.
- 2- Inject epoxy into the holes and insert the dowel, twisting it as it is being pushed into the hole. Inject only enough epoxy to fill the hole when the dowel is completely inserted. Clean off any epoxy that oozes from the hole taking care to keep it off of the faces of the marker. Allow the epoxy to fully cure before moving the marker.
- 3- Using a template to ensure accuracy, core-drill holes into the foundation pad or beam. Ensure the holes are plumb by using a bubble level or similar to check the angle of the drill while drilling. Use a 25mm (1") diameter diamond core drill. Drill the holes 150mm (6") deep, over-drill the depth of the hole slightly if necessary to ensure that the dowel does not bottom out when the marker is set on the foundation (measure the depth of the hole and compare with length of exposed dowel protruding from the marker). Clean the holes of all dust or excess water using oil free compressed air.
- 4- Fill holes in foundation one half to two thirds full of epoxy. Carefully and slowly lower the marker onto the foundation. After the marker is fully seated on the foundation, temporarily lift the marker several inches and check to see that the epoxy in the holes has filled the hole to the top. Add more epoxy as required to fill the hole when the marker is fully seated, and re-lower the marker.

- 5- Check marker alignment and use small wood shims to level and align the marker. Complete all adjustments within the gel time of the epoxy. Clean any epoxy that may have oozed out from beneath the marker if this is an exposed foundation emplacement. Use lacquer thinner to clean the epoxy.
- 6- Allow the epoxy to fully cure before removing shims and backfilling topsoil around marker.

Attachment 4

Photo Guidelines for Contractors

(rev. Dec. 22)

The Contractor must take a photo of each repaired or newly installed marker and send them to the Veterans Affairs Canada (VAC) Project Authority. The photos are used to verify that all work requirements have been met and to update the VAC grave marker database.

The Contractor is not required to take photos of the markers before the repairs are completed.

Photos must be submitted in the appropriate layout, size and format as follows:

Photos of Upright Markers

Layout: Portrait Mode

Size: the size of the photo must be within the following range:
minimum 200 KB to maximum 1 MB

Format: JPG file (.JPG)

The base of the marker and any visible foundation must be included in the photo (see example).



Figure 1 - Example – photo of upright marker

Photos of Flat Markers

Layout: Landscape Mode

Size: the size of the photo must be within the following range:
minimum 200 KB to maximum 1 MB

Format: JPG file (.JPG)

Any visible foundation must be included in the photo (see example)



Figure 2 - Example – photo of flat marker

Tips

- Photos may be taken in a size larger than 1 MB and reduced later; however, if the original size is too small (i.e. smaller than 200 KB), the photos can't be enlarged without becoming blurry.
- Avoid casting a shadow on the marker; however, in cases of extreme glare it may be necessary to shadow out the entire marker.

Submitting Photos

The Contractor must save the photos in a photo folder on a cloud storage website (i.e. file transfer site, GoogleDrive, drop-box, etc.) and send the link to the folder by e-mail to the VAC Project Authority.

There is no requirement for the Contractor to re-name the photos.

Any photos not submitted in accordance with the Photo Guidelines must be re-done at the expense of the Contractor. Invoices will not be paid until proper photos have been received by the VAC Project Authority.

For additional information about taking and submitting photos, please contact the VAC Project Authority.

Attachment 5

List of Repairs and Cemeteries

| Area A - Zone BC04 - Kootenay Boundary | | | |
|-----------------------------------------------------------------|--------------------|----------------------|---------------------|
| Cemetery Info | Marker Type | Work Required | # of Markers |
| BC04004 Greenwood Cemetery Boundary Road Greenwood, BC | Flat | Replace Marker | 1 |
| | Flat | Clean | 7 |
| | Flat | Clean & Edge grass | 1 |
| Total | | | 9 |

| Area B - Zone BC07 - Greater Vancouver | | | |
|-----------------------------------------------------------------------|--------------------|----------------------|---------------------|
| Cemetery Info | Marker Type | Work Required | # of Markers |
| BC07003 Boundary Bay Cemetery 862 56St Delta (Tsawwassen) BC | Flat | Align | 11 |
| | Flat | Align & Clean | 3 |
| | Upright | Align | 1 |
| Total | | | 15 |

| Area C - Zone BC10 - Port Alberni / Tofino | | | |
|-----------------------------------------------------------------|--------------------|----------------------|---------------------|
| Cemetery Info | Marker Type | Work Required | # of Markers |
| BC10001 Seaview Cemetery Pacific Rim Highway Tofino BC | Flat | Clean | 4 |
| BC10005 Morpheus Cemetery Morpheus Island Tofino BC | Flat | Clean | 1 |
| Total | | | 5 |

| Area D - Zone BC15 - Thomspson - Nicola | | | |
|----------------------------------------------------------------|--------------------|----------------------|---------------------|
| Cemetery Info | Marker Type | Work Required | # of Markers |
| BC15003 Pleasant Street Cemetery 8th Ave Kamloops BC | Flat | Align | 25 |
| | Flat | Align & Clean | 1 |
| | Flat | New Foundation | 1 |
| | Flat | Clean | 22 |
| | Upright | Align | 6 |
| | Upright | Align & Clean | 1 |
| | Upright | New Foundation | 3 |
| | Upright | Clean | 2 |
| BC15008 Lytton Public 179 Pondarose Heights Lytton BC | Flat | Clean | 11 |
| | Upright | Clean | 3 |
| Total | | | 75 |

| Area E - Zone BC17 - North Okanagan | | | |
|---------------------------------------------------------------|--------------------|----------------------|---------------------|
| Cemetery Info | Marker Type | Work Required | # of Markers |
| BC17004 Pleasant Valley Pleasant Valley Rd Vernon BC | Flat | Clean | 2 |
| | Upright | Align | 1 |
| | Upright | Align & Clean | 1 |
| Total | | | 4 |

| Area F - Zone BC19 - Cariboo | | | |
|------------------------------------------------------------------------------|--------------------|---------------------------|---------------------|
| Cemetery Info | Marker Type | Work Required | # of Markers |
| BC19002 Quesnel Pioneer Carson Ave Quesnel BC | Flat | Align | 1 |
| | Flat | Align & Clean | 6 |
| | Flat | Align & Pin to Foundation | 1 |
| | Upright | New Foundation & Clean | 5 |
| | Upright | Clean | 1 |
| BC19004 Quesnel and District Cemetery Quesnel Hixon Road Quesnel BC | Flat | Align | 5 |
| | Flat | Align & Clean | 41 |
| | Flat | Clean | 9 |
| BC19022 McKinley Pioneer 4089 McKinley Dr Lac La Hache BC | Flat | Align & Clean | 1 |
| | Flat | Clean | 3 |
| | Upright | Replace marker | 1 |
| | Upright | Clean | 1 |
| Total | | | 75 |

| Area G - Zone BC20 - Mount Waddington | | | |
|----------------------------------------------------------------------------------------|--------------------|----------------------|---------------------|
| Cemetery Info | Marker Type | Work Required | # of Markers |
| BC20002 Sayward Burial Park 1328 Sayward Rd Sayward BC | Flat | Clean | 4 |
| BC20003 Christ Church Anglican Broughton Street @ Gatu Street Alert Bay BC | Flat | Align & Clean | 2 |
| | Flat | Clean | 9 |
| BC20005 Memorial Park Cemetery 6100 Byng Road & Bronze Road Port Hardy BC | Flat | Clean | 4 |
| Total | | | 19 |

| Area H - Zone BC22 - Skeena/Haida Gwaii | | | |
|----------------------------------------------------------------------------|--------------------|----------------------|---------------------|
| Cemetery Info | Marker Type | Work Required | # of Markers |
| BC22002 Fairview Cemetery Fairview Ave Prince Rupert BC | Flat | Replace Marker | 4 |
| | Flat | Align | 2 |
| | Flat | Align & Clean | 7 |
| | Flat | Clean | 113 |
| | Upright | Clean | 3 |
| BC22005 Port Clements Cemetery Adams Road Port Clements BC | Flat | Clean | 1 |
| BC22006 Queen Charlotte Cemetery Cemetery Road Queen Charlotte BC | Flat | Clean | 2 |
| BC22007 Tlell Cemetery Highway 16 Tlell BC | Flat | Clean | 3 |
| Total | | | 135 |

| Area I - Zone BC23 - Kitimat/Stikine | | | |
|----------------------------------------------------------------------------------|--------------------|----------------------|---------------------|
| Cemetery Info | Marker Type | Work Required | # of Markers |
| BC23003 Terrace Municipal Cemetery 238 Kalum Lake Rd Terrace BC | Flat | Align | 1 |
| | Flat | Align & Clean | 5 |
| | Flat | Clean | 33 |
| | Upright | Align & Clean | 1 |
| BC23007 Kitsumgallum-Pioneer Cemetery 101 Kalum Lake Road Terrace BC | Flat | Clean | 15 |
| | Upright | Align & Clean | 5 |
| | Upright | Clean | 7 |
| Total | | | 67 |

| Area J - Zone BC24 - Bulkley/Nechako | | | |
|--------------------------------------------------------------------------|--------------------|---------------------------|---------------------|
| Cemetery Info | Marker Type | Work Required | # of Markers |
| BC24002 Rose Lake Cemetery 27148 Hwy16 Rose Lake BC | Flat | New Foundation & Clean | 1 |
| BC24003 Smithers Municipal 1958 Dominion Street Smithers BC | Flat | Align | 1 |
| | Flat | Align & Clean | 1 |
| | Flat | New Foundation | 1 |
| | Flat | Clean | 39 |
| | Upright | Clean | 8 |
| BC24004 Burns Lake Municipal Hwy 16 Burns Lake BC | Flat | Align & Clean | 5 |
| | Flat | Clean | 19 |
| | Upright | Clean | 1 |
| BC24007 Houston Municipal Cemetery 3480 Viewmont Crt Houston BC | Flat | Clean | 3 |
| BC24008 Telkwa Cemetery 1450 Tyhee Rd Telkwa BC | Flat | Align & Clean | 2 |
| | Flat | Clean | 4 |
| BC24009 Topley Cemetery 22597 Howell Rd Topley BC | Flat | Clean | 1 |
| BC24011 Fort Fraser Cemetery 19128 Clarke Road Fort Fraser BC | Flat | Clean | 2 |
| BC24012 Fraser Lake Tunasa Cr Fraser Lake BC | Flat | Clean | 1 |
| | Upright | New Foundation | 2 |
| Total | | | 91 |

| Area K - Zone BC25 - Fraser/Fort George | | | |
|----------------------------------------------------------------------------------|--------------------|------------------------|---------------------|
| Cemetery Info | Marker Type | Work Required | # of Markers |
| BC25001 McBride Cemetery Airport Rd McBride BC | Flat | Align & Clean | 8 |
| | Flat | Clean | 5 |
| BC25002 Memorial Park Cemetery 3300 Memorial Park Lane Prince George BC | Flat | Replace Marker | 2 |
| | Flat | Align | 17 |
| | Flat | Align & Clean | 115 |
| | Flat | New Foundation | 1 |
| | Flat | New Foundation & Clean | 6 |
| | Flat | Clean | 125 |
| | Flat | Clean & Pin | 1 |
| | Upright | Align & Clean | 1 |
| | Upright | New Foundation | 2 |
| | Upright | New Foundation & Clean | 5 |
| | Upright | Clean | 3 |
| Totals | | | 291 |

| Area L - Zone BC26 - Stikine Region | | | |
|------------------------------------------------------------------------|--------------------|------------------------|---------------------|
| Cemetery Info | Marker Type | Work Required | # of Markers |
| BC26001 Cecil Lake Cemetery Cecil Lake Rd Cecil Lake BC | Flat | Clean | 3 |
| | Upright | Clean | 1 |
| BC26002 Woodlawn 12374 St Fort St John BC | Flat | Replace Marker | 1 |
| | Flat | Align | 1 |
| | Flat | Align & Clean | 13 |
| | Flat | Clean | 2 |
| | Upright | Align | 1 |
| BC26003 Fort St John Municipal 9504-100th Ave Fort St John BC | Flat | Align | 26 |
| | Flat | Clean | 1 |
| BC26004 Rolla Community Sweetwater Rd Rolla BC | Flat | Align & Clean | 1 |
| | Flat | Clean | 1 |
| | Upright | Align | 4 |
| BC26005 Pioneer Municipal Cemetery 108th Ave Dawson Creek BC | Flat | Align | 2 |
| | Flat | New Foundation & Clean | 2 |
| BC26007 Dawson Creek Municipal Hwy 97 Dawson Creek BC | Flat | Align | 3 |
| | Flat | Align & Clean | 3 |
| | Flat | Clean | 23 |
| | Upright | Align | 1 |
| | Upright | New Foundation | 1 |
| | Upright | Clean | 1 |
| BC26011 Briar Ridge Cemetery 8041 Road 201 Briar Ridge BC | Upright | New Foundation | 1 |
| BC26014 Riverview Cemetery Briar Ridge Road Pouce Coupe BC | Flat | Align & Clean | 1 |
| | Flat | Clean | 3 |
| | Upright | New Foundation | 1 |
| BC26017 Sunset Prairie 6016 - 261 Rd Sunset Prairie BC | Flat | New Foundation & Clean | 1 |
| | Upright | Clean | 1 |
| BC26018 Mountainview Cemetery 7900 Highway 97 Groundbirch BC | Flat | Clean | 2 |

| | | | |
|---------------------------------------------------------------------------------|---------|----------------|------------|
| BC26022 Peace Valley Memorial Garden 9560 Spruce Street N Taylor BC | Flat | Align | 2 |
| BC26023 Hill of Rest Cemetery Northpine Road North Pine BC | Flat | Clean | 2 |
| BC26024 Rose Prairie Cemetery 15820 Road 261 Rose Prairie BC | Flat | Align & Clean | 1 |
| BC26025 Montney Cemetery 15438 Road 271 (Montney Road) Montney BC | Flat | Align & Clean | 2 |
| | Flat | Clean | 2 |
| BC26026 Garden of Peace Powell Road Hudson's Hope BC | Upright | Replace marker | 1 |
| | Upright | Align | 1 |
| | Upright | Clean | 1 |
| Total | | | 113 |

| Area M - Zone BC28 - Northern Rockies | | | |
|-----------------------------------------------------------------------------|--------------------|----------------------|---------------------|
| Cemetery Info | Marker Type | Work Required | # of Markers |
| BC28001 Fort Nelson Municipal 7400 Wildflower Drive Fort Nelson BC | Flat | Clean | 1 |
| | Upright | Align | 2 |
| Total | | | 3 |

**ANNEX “B”
BASIS OF PAYMENT**

The following statement applies to each zone.

In consideration of the Contractor satisfactorily completing all of its obligations under the Contract, the Contractor will be paid in accordance to the rates outlined below.

Pricing is firm for the duration of the Contract. Rates are all-inclusive.

*** Should there be unexpected complications in completing the repairs listed below, the amount of the contingency fund may be accessed but must not exceed 10 % of the Total Cost as calculated below. Prior to starting any additional work under the contingency fund, the Contractor must contact the VAC Project Authority for approval.**

| B.1 | | | | | |
|-----------------------------------------------------------------|--------------------|-----------------------|---------------------|----------------------|-------------------|
| Area A - Zone BC04 - Kootenay Boundary | | | | | |
| Cemetery Info | Marker Type | Work Required | # of Markers | \$ per Marker | Total Cost |
| BC04004 Greenwood Cemetery Boundary Road Greenwood, BC | Flat | Replace Marker | 1 | | |
| | Flat | Clean | 7 | | |
| | Flat | Clean & Edge grass | 1 | | |
| Total | | | 9 | | |
| A – Total for all Cemeteries in Area A Zone BC04 | | | | | |
| B – Contingency (A x 10%) | | | | | |
| C – Sub-total for A + B | | | | | |
| D – Applicable Taxes (5%) | | | | | |
| E – Grand Total of Area A Zone BC04 (C + D) | | | | | |

| B.2 | | | | | |
|-----------------------------------------------------------------------------|--------------------|----------------------|---------------------|----------------------|-------------------|
| Area B - Zone BC07 - Greater Vancouver | | | | | |
| Cemetery Info | Marker Type | Work Required | # of Markers | \$ per Marker | Total Cost |
| BC07003 Boundary Bay Cemetery 862 56St Delta (Tsawwassen) BC | Flat | Align | 11 | | |
| | Flat | Align & Clean | 3 | | |
| | Upright | Align | 1 | | |
| Total | | | 15 | | |
| A – Total for all Cemeteries in Area B Zone BC07 | | | | | |
| B – Contingency (A x 10%) | | | | | |
| C – Sub-total for A + B | | | | | |
| D – Applicable Taxes (5%) | | | | | |
| E – Grand Total of Area B Zone BC07 (C + D) | | | | | |

| B.3 | | | | | |
|-----------------------------------------------------------------|--------------------|----------------------|---------------------|----------------------|-------------------|
| Area C - Zone BC10 - Port Alberni / Tofino | | | | | |
| Cemetery Info | Marker Type | Work Required | # of Markers | \$ per Marker | Total Cost |
| BC10001 Seaview Cemetery Pacific Rim Highway Tofino BC | Flat | Clean | 4 | | |
| BC10005 Morpheus Cemetery Morpheus Island Tofino BC | Flat | Clean | 1 | | |
| Total | | | 5 | | |
| A – Total for all Cemeteries in Area C Zone BC10 | | | | | |
| B – Contingency (A x 10%) | | | | | |
| C – Sub-total for A + B | | | | | |
| D – Applicable Taxes (5%) | | | | | |
| E – Grand Total of Area C Zone BC10 (C + D) | | | | | |

| B.4 | | | | | |
|-------------------------------------------------------------------|--------------------|----------------------|---------------------|----------------------|-------------------|
| Area D - Zone BC15 - Thomspon - Nicola | | | | | |
| Cemetery Info | Marker Type | Work Required | # of Markers | \$ per Marker | Total Cost |
| BC15003 Pleasant Street Cemetery 8th Ave Kamloops BC | Flat | Align | 25 | | |
| | Flat | Align & Clean | 1 | | |
| | Flat | New Foundation | 1 | | |
| | Flat | Clean | 22 | | |
| | Upright | Align | 6 | | |
| | Upright | Align & Clean | 1 | | |
| | Upright | New Foundation | 3 | | |
| | Upright | Clean | 2 | | |
| BC15008 Lytton Public 179 Pondarose Heights Lytton BC | Flat | Clean | 11 | | |
| | Upright | Clean | 3 | | |
| Total | | | 75 | | |
| A – Total for all Cemeteries in Area D Zone BC15 | | | | | |
| B – Contingency (A x 10%) | | | | | |
| C – Sub-total for A + B | | | | | |
| D – Applicable Taxes (5%) | | | | | |
| E – Grand Total of Area D Zone BC15 (C + D) | | | | | |

| B.5 | | | | | |
|---------------------------------------------------------------|--------------------|----------------------|---------------------|----------------------|-------------------|
| Area E - Zone BC17 - North Okanagan | | | | | |
| Cemetery Info | Marker Type | Work Required | # of Markers | \$ per Marker | Total Cost |
| BC17004 Pleasant Valley Pleasant Valley Rd Vernon BC | Flat | Clean | 2 | | |
| | Upright | Align | 1 | | |
| | Upright | Align & Clean | 1 | | |
| Total | | | 4 | | |
| A – Total for all Cemeteries in Area E Zone BC17 | | | | | |
| B – Contingency (A x 10%) | | | | | |
| C – Sub-total for A + B | | | | | |
| D – Applicable Taxes (5%) | | | | | |
| E – Grand Total of Area E Zone BC17 (C + D) | | | | | |

| B.6 | | | | | |
|---------------------------------------------------------------------------------|--------------------|---------------------------|---------------------|----------------------|-------------------|
| Area F - Zone BC19 - Cariboo | | | | | |
| Cemetery Info | Marker Type | Work Required | # of Markers | \$ per Marker | Total Cost |
| BC19002 Quesnel Pioneer Carson Ave Quesnel BC | Flat | Align | 1 | | |
| | Flat | Align & Clean | 6 | | |
| | Flat | Align & Pin to Foundation | 1 | | |
| | Upright | New Foundation & Clean | 5 | | |
| | Upright | Clean | 1 | | |
| BC19004 Quesnel and District Cemetery Quesnel Hixon Road Quesnel BC | Flat | Align | 5 | | |
| | Flat | Align & Clean | 41 | | |
| | Flat | Clean | 9 | | |
| BC19022 McKinley Pioneer 4089 McKinley Dr Lac La Hache BC | Flat | Align & Clean | 1 | | |
| | Flat | Clean | 3 | | |
| | Upright | Replace marker | 1 | | |
| | Upright | Clean | 1 | | |
| Total | | | 75 | | |
| A – Total for all Cemeteries in Area F Zone BC19 | | | | | |
| B – Contingency (A x 10%) | | | | | |
| C – Sub-total for A + B | | | | | |
| D – Applicable Taxes (5%) | | | | | |
| E – Grand Total of Area F Zone BC19 (C + D) | | | | | |

| B.7 | | | | | |
|-------------------------------------------------------------------------------------------|--------------------|----------------------|---------------------|----------------------|-------------------|
| Area G - Zone BC20 - Mount Waddington | | | | | |
| Cemetery Info | Marker Type | Work Required | # of Markers | \$ per Marker | Total Cost |
| BC20002 Sayward Burial Park 1328 Sayward Rd Sayward BC | Flat | Clean | 4 | | |
| BC20003 Christ Church Anglican Broughton Street @ Gatu Street Alert Bay BC | Flat | Align & Clean | 2 | | |
| | Flat | Clean | 9 | | |
| BC20005 Memorial Park Cemetery 6100 Byng Road & Bronze Road Port Hardy BC | Flat | Clean | 4 | | |
| Total | | | 19 | | |
| A – Total for all Cemeteries in Area G Zone BC20 | | | | | |
| B – Contingency (A x 10%) | | | | | |
| C – Sub-total for A + B | | | | | |
| D – Applicable Taxes (5%) | | | | | |
| E – Grand Total of Area G Zone BC20 (C + D) | | | | | |

| B.8 | | | | | |
|----------------------------------------------------------------------------|--------------------|----------------------|---------------------|----------------------|-------------------|
| Area H - Zone BC22 - Skeena/Haida Gwaii | | | | | |
| Cemetery Info | Marker Type | Work Required | # of Markers | \$ per Marker | Total Cost |
| BC22002 Fairview Cemetery Fairview Ave Prince Rupert BC | Flat | Replace Marker | 4 | | |
| | Flat | Align | 2 | | |
| | Flat | Align & Clean | 7 | | |
| | Flat | Clean | 113 | | |
| | Upright | Clean | 3 | | |
| BC22005 Port Clements Cemetery Adams Road Port Clements BC | Flat | Clean | 1 | | |
| BC22006 Queen Charlotte Cemetery Cemetery Road Queen Charlotte BC | Flat | Clean | 2 | | |
| BC22007 Tiell Cemetery Highway 16 Tiell BC | Flat | Clean | 3 | | |
| Total | | | 135 | | |
| A – Total for all Cemeteries in Area H Zone BC22 | | | | | |
| B – Contingency (A + 10%) | | | | | |
| C – Sub-total for A + B | | | | | |
| D – Applicable Taxes (5%) | | | | | |
| E – Grand Total of Area H Zone BC22 (C + D) | | | | | |

| B.9 | | | | | |
|----------------------------------------------------------------------------------|--------------------|----------------------|---------------------|----------------------|-------------------|
| Area I - Zone BC23 - Kitimat/Stikine | | | | | |
| Cemetery Info | Marker Type | Work Required | # of Markers | \$ per Marker | Total Cost |
| BC23003 Terrace Municipal Cemetery 238 Kalum Lake Rd Terrace BC | Flat | Align | 1 | | |
| | Flat | Align & Clean | 5 | | |
| | Flat | Clean | 33 | | |
| | Upright | Align & Clean | 1 | | |
| BC23007 Kitsumgallum-Pioneer Cemetery 101 Kalum Lake Road Terrace BC | Flat | Clean | 15 | | |
| | Upright | Align & Clean | 5 | | |
| | Upright | Clean | 7 | | |
| Total | | | 67 | | |
| A – Total for all Cemeteries in Area I Zone BC23 | | | | | |
| B – Contingency (A + 10%) | | | | | |
| C – Sub-total for A + B | | | | | |
| D – Applicable Taxes (5%) | | | | | |
| E – Grand Total of Area I Zone BC23 (C + D) | | | | | |

| B.10 | | | | | |
|--------------------------------------------------------------------------|--------------------|------------------------|---------------------|----------------------|-------------------|
| Area J - Zone BC24 - Bulkley/Nechako | | | | | |
| Cemetery Info | Marker Type | Work Required | # of Markers | \$ per Marker | Total Cost |
| BC24002 Rose Lake Cemetery 27148 Hwy16 Rose Lake BC | Flat | New Foundation & Clean | 1 | | |
| BC24003 Smithers Municipal 1958 Dominion Street Smithers BC | Flat | Align | 1 | | |
| | Flat | Align & Clean | 1 | | |
| | Flat | New Foundation | 1 | | |
| | Flat | Clean | 39 | | |
| | Upright | Clean | 8 | | |
| BC24004 Burns Lake Municipal Hwy 16 Burns Lake BC | Flat | Align & Clean | 5 | | |
| | Flat | Clean | 19 | | |
| | Upright | Clean | 1 | | |
| BC24007 Houston Municipal Cemetery 3480 Viewmont Crt Houston BC | Flat | Clean | 3 | | |
| BC24008 Telkwa Cemetery 1450 Tyhee Rd Telkwa BC | Flat | Align & Clean | 2 | | |
| | Flat | Clean | 4 | | |
| BC24009 Topley Cemetery 22597 Howell Rd Topley BC | Flat | Clean | 1 | | |
| BC24011 Fort Fraser Cemetery 19128 Clarke Road Fort Fraser BC | Flat | Clean | 2 | | |
| BC24012 Fraser Lake Tunasa Cr Fraser Lake BC | Flat | Clean | 1 | | |
| | Upright | New Foundation | 2 | | |
| Total | | | 91 | | |
| A – Total for all Cemeteries in Area J Zone BC24 | | | | | |
| B – Contingency (A x 10%) | | | | | |
| C – Sub-total for A + B | | | | | |
| D – Applicable Taxes (5%) | | | | | |
| E – Grand Total of Area J Zone BC24 (C + D) | | | | | |

| B.11 | | | | | |
|----------------------------------------------------------------------------------------|--------------------|------------------------------|---------------------|----------------------|-------------------|
| Area K - Zone BC25 - Fraser/Fort George | | | | | |
| Cemetery Info | Marker Type | Work Required | # of Markers | \$ per Marker | Total Cost |
| BC25001 McBride Cemetery Airport Rd McBride BC | Flat | Align & Clean | 8 | | |
| | Flat | Clean | 5 | | |
| BC25002 Memorial Park Cemetery 3300 Memorial Park Lane Prince George BC | Flat | Replace Marker | 2 | | |
| | Flat | Align | 17 | | |
| | Flat | Align & Clean | 115 | | |
| | Flat | New Foundation | 1 | | |
| | Flat | New Foundation & Clean | 6 | | |
| | Flat | Clean | 125 | | |
| | Flat | Clean & Pin | 1 | | |
| | Upright | Align & Clean | 1 | | |
| | Upright | New Foundation | 2 | | |
| | Upright | New Foundation & Clean | 5 | | |
| | Upright | Clean | 3 | | |
| Totals | | | 291 | | |
| A – Total for all Cemeteries in Area K Zone BC25 | | | | | |
| B – Contingency (A x 10%) | | | | | |
| C – Sub-total for A + B | | | | | |
| D – Applicable Taxes (5%) | | | | | |
| E – Grand Total of Area K Zone BC25 (C + D) | | | | | |

| B.12 | | | | | |
|--------------------------------------------------------------------------|--------------------|------------------------|---------------------|----------------------|-------------------|
| Area L - Zone BC26 - Stikine Region | | | | | |
| Cemetery Info | Marker Type | Work Required | # of Markers | \$ per Marker | Total Cost |
| BC26001 Cecil Lake Cemetery Cecil Lake Rd Cecil Lake BC | Flat | Clean | 3 | | |
| | Upright | Clean | 1 | | |
| BC26002 Woodlawn 12374 St Fort St John BC | Flat | Replace Marker | 1 | | |
| | Flat | Align | 1 | | |
| | Flat | Align & Clean | 13 | | |
| | Flat | Clean | 2 | | |
| | Upright | Align | 1 | | |
| BC26003 Fort St John Municipal 9504-100th Ave Fort St John BC | Flat | Align | 26 | | |
| | Flat | Clean | 1 | | |
| BC26004 Rolla Community Sweetwater Rd Rolla BC | Flat | Align & Clean | 1 | | |
| | Flat | Clean | 1 | | |
| | Upright | Align | 4 | | |
| BC26005 Pioneer Municipal Cemetery 108th Ave Dawson Creek BC | Flat | Align | 2 | | |
| | Flat | New Foundation & Clean | 2 | | |
| BC26007 Dawson Creek Municipal Hwy 97 Dawson Creek BC | Flat | Align | 3 | | |
| | Flat | Align & Clean | 3 | | |
| | Flat | Clean | 23 | | |
| | Upright | Align | 1 | | |
| | Upright | New Foundation | 1 | | |
| | Upright | Clean | 1 | | |
| BC26011 Briar Ridge Cemetery 8041 Road 201 Briar Ridge BC | Upright | New Foundation | 1 | | |
| BC26014 Riverview Cemetery Briar Ridge Road Pouce Coupe BC | Flat | Align & Clean | 1 | | |
| | Flat | Clean | 3 | | |
| | Upright | New Foundation | 1 | | |
| BC26017 Sunset Prairie 6016 - 261 Rd | Flat | New Foundation & Clean | 1 | | |

| | | | | | |
|---------------------------------------------------------------------------------|---------|-------------------|------------|--|--|
| Sunset Prairie BC | Upright | Clean | 1 | | |
| BC26018 Mountainview Cemetery 7900 Highway 97 Groundbirch BC | Flat | Clean | 2 | | |
| BC26022 Peace Valley Memorial Garden 9560 Spruce Street N Taylor BC | Flat | Align | 2 | | |
| BC26023 Hill of Rest Cemetery Northpine Road North Pine BC | Flat | Clean | 2 | | |
| BC26024 Rose Prairie Cemetery 15820 Road 261 Rose Prairie BC | Flat | Align & Clean | 1 | | |
| BC26025 Montney Cemetery 15438 Road 271 (Montney Road) Montney BC | Flat | Align & Clean | 2 | | |
| | Flat | Clean | 2 | | |
| BC26026 Garden of Peace Powell Road Hudson's Hope BC | Upright | Replace marker | 1 | | |
| | Upright | Align | 1 | | |
| | Upright | Clean | 1 | | |
| Total | | | 113 | | |
| A – Total for all Cemeteries in Area L Zone BC26 | | | | | |
| B – Contingency (A x 10%) | | | | | |
| C – Sub-total for A + B | | | | | |
| D – Applicable Taxes (5%) | | | | | |
| E – Grand Total of Area L Zone BC26 (C + D) | | | | | |

| B.13 | | | | | |
|-----------------------------------------------------------------------------|--------------------|----------------------|---------------------|----------------------|-------------------|
| Area M - Zone BC28 - Northern Rockies | | | | | |
| Cemetery Info | Marker Type | Work Required | # of Markers | \$ per Marker | Total Cost |
| BC28001 Fort Nelson Municipal 7400 Wildflower Drive Fort Nelson BC | Flat | Clean | 1 | | |
| | Upright | Align | 2 | | |
| Total | | | 3 | | |
| A – Total for all Cemeteries in Area M Zone BC28 | | | | | |
| B – Contingency (A x 10%) | | | | | |
| C – Sub-total for A + B | | | | | |
| D – Applicable Taxes (5%) | | | | | |
| E – Grand Total of Area M Zone BC28 (C + D) | | | | | |

ANNEX "C"
MANDATORY TECHNICAL EVALUATION CRITERIA
Instructions to Bidders

The Bidder must clearly demonstrate their experience by providing a description of the previous projects or work experience. They must also indicate when the work was carried out.

In the case where the timelines of two or more projects or experience overlap, the timeframe of the overlap will only be counted once.

The Bidder may use the template attached in Annex "D" – Bidder's Project Template, for each project submitted in order to demonstrate the mandatory technical evaluation criteria.

For each project or work experience the Bidder should provide:

- **The name of the client or organization;**
- **Name and phone number of the client's representative;**
- **The period during which the service was provided (month and year);**
- **A brief outline of the service(s) provided.**

Mandatory Technical Criteria

Proposals must meet all of the following mandatory requirements

1. The Bidder must demonstrate a minimum of 12 months of cumulative experience providing two (2) or more aspects of grave marker maintenance.
2. The Bidder must demonstrate a minimum of 12 months of cumulative experience performing landscaping tasks.

Definitions:

Grave marker maintenance: Includes the alignment, levelling, cleaning, grouting, of grave markers and/or monuments and the installation of new bases, foundations and/or grave markers.

Client or organization: Includes but is not limited to work experience with funeral home(s), church(es), community group(s), municipalities, Commonwealth War Graves Commission, Veterans Affairs Canada.

ANNEX "D"
BIDDER'S PROJECT TEMPLATE

| | |
|----------------------------------------------------------------------|--|
| Name of Client or Organization | |
| Name of Client's representative | |
| Phone number of the client's representative | |
| Period during which the service was provided (month and year) | |
| Description of the Service(s) provided. | |