

2 METRE A-FRAME
EXACT HEIGHT TO CENTRE OF 25# WIRE ROPE IN MAIN CABLE SHEAVE = 2.352 METRES (WITHOUT FOOT PIECE)

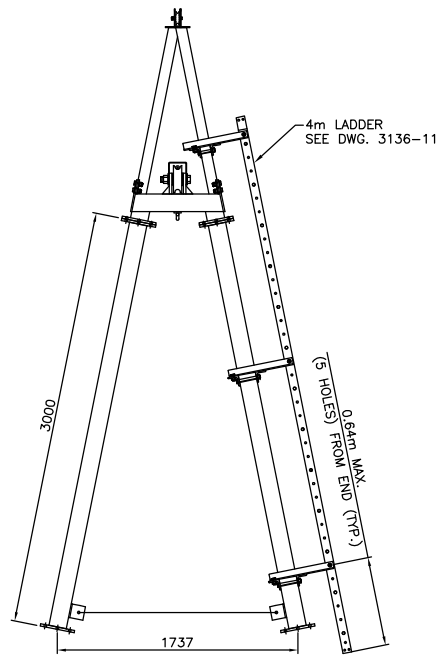

3 METRE A-FRAME
EXACT HEIGHT TO CENTRE OF 25# WIRE ROPE IN MAIN CABLE SHEAVE = 3.332 METRES (WITHOUT FOOT PIECE)

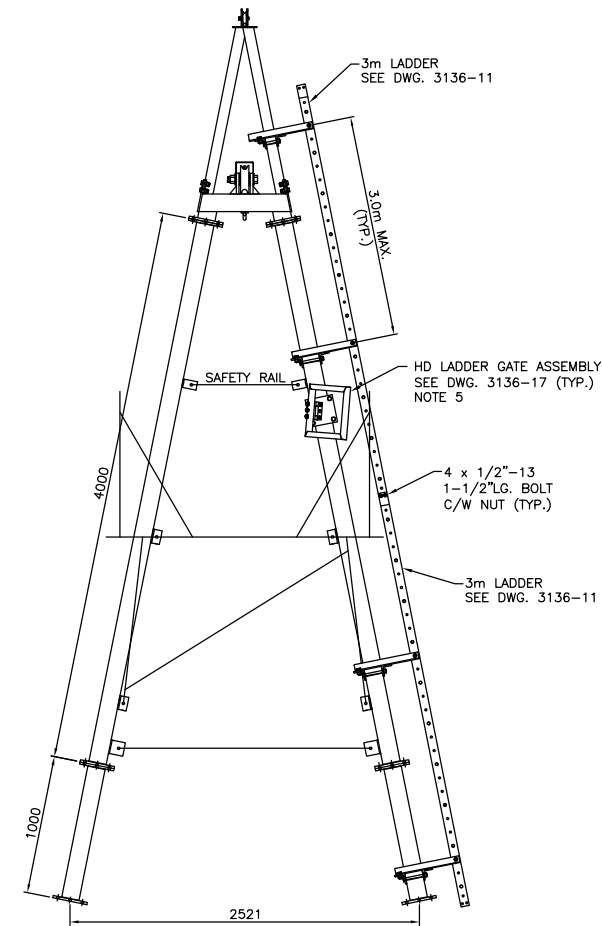

5 METRE A-FRAME
EXACT HEIGHT TO CENTRE OF 25# WIRE ROPE IN MAIN CABLE SHEAVE = 5.294 METRES (WITHOUT FOOT PIECE)

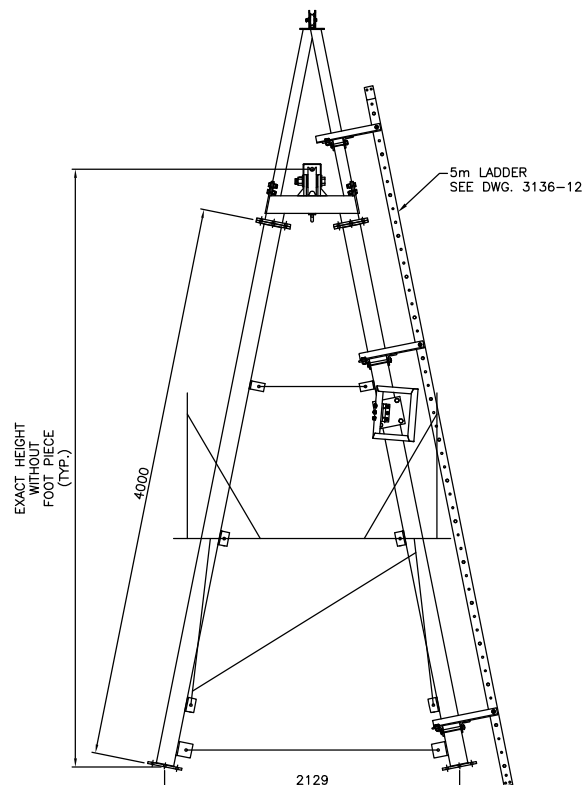

4 METRE A-FRAME
(THIS SECTION IS TYPICAL OF ALL FRAMES OVER 4 METRES)
EXACT HEIGHT TO CENTRE OF 25# WIRE ROPE IN MAIN CABLE SHEAVE = 4.313 METRES (WITHOUT FOOT PIECE)

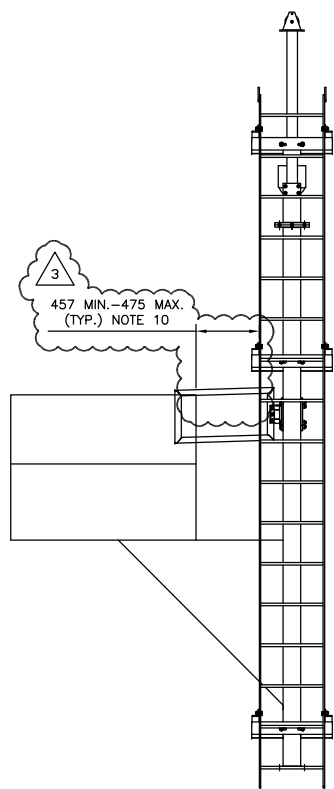

4 METRE A-FRAME SECTION

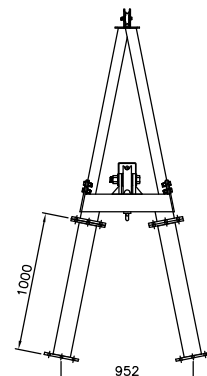

1 METRE A-FRAME
EXACT HEIGHT TO CENTRE OF 25# WIRE ROPE IN MAIN CABLE SHEAVE = 1.371 METRES (WITHOUT FOOT PIECE)

DESIGN LOAD	
CAR	200
2 MEN	400
REEL	50
	650 lbs.

PLUS SNAG LOAD OF 1/8" WIRE ROPE AT ANY ANGLE = 1600 lbs. BREAKING STRENGTH.

NOTES:

- ALL PARTS TO BE HOT-DIPPED GALVANIZED AS PER ASTM A123/A123M.
- ALL BOLTS & NUTS TO BE M16 A325M TYPE 2 GALVANIZED, UNLESS OTHERWISE NOTED.
- ALL STEEL SHALL CONFORM TO C.S.A. G40.21M GRADE 350W GALVANIZED, UNLESS OTHERWISE NOTED.
- LADDER BRACKET SPACING; 3.0m MAX. AND 0.64m MAX. (5 HOLES) FROM ENDS.
- HD LADDER GATE ASSEMBLY TO BE INSTALLED SO TOP OF GATE IS LEVEL WITH TOP OF PLATFORM RAILING.
- LADDERS ARE DESIGNED TO MEET ANSI14.3-2008 REQUIREMENTS.
- LADDER TO BE OCCUPIED BY MAX. 1 PERSONS AT ANY GIVEN TIME.
- FIELD MODIFY EXISTING PLATFORM RAILING TO CLEARANCE OF 457mm MIN.-475mm MAX. FROM BACK OF RAILING TO O/S LADDER SIDE RAIL.

ALL DIMENSIONS IN MILLIMETRES UNLESS OTHERWISE NOTED



BILLS OF MATERIAL

A COMPLETE 2 METRE A-FRAME ASSEMBLY CONSISTS OF THE FOLLOWING:

QTY	DESCRIPTION	DWG No.	SUPPLIER
1	A-FRAME TOP ASSEMBLY	3136-4	CONTRACTOR
1	2 METRE LEG ASSEMBLY	3136-5	CONTRACTOR
1	1.1 METRE HORIZONTAL BRACE ASSEMBLY	3136-6	CONTRACTOR
1	CAR HOOK ASSEMBLY LEG	3136-10	CONTRACTOR
2	LADDER BRACKET ASSEMBLY	3136-13	CONTRACTOR
1	3m LADDER	3136-11	CONTRACTOR

A COMPLETE 3 METRE A-FRAME ASSEMBLY CONSISTS OF THE FOLLOWING:

QTY	DESCRIPTION	DWG No.	SUPPLIER
1	A-FRAME TOP ASSEMBLY	3136-4	CONTRACTOR
1	3 METRE LEG ASSEMBLY	3136-5	CONTRACTOR
1	1.5 METRE HORIZONTAL BRACE ASSEMBLY	3136-6	CONTRACTOR
1	CAR HOOK ASSEMBLY LEG	3136-10	CONTRACTOR
3	LADDER BRACKET ASSEMBLY	3136-13	CONTRACTOR
1	4m LADDER	3136-11	CONTRACTOR

A COMPLETE 4 METRE A-FRAME ASSEMBLY CONSISTS OF THE FOLLOWING:

QTY	DESCRIPTION	DWG No.	SUPPLIER
1	A-FRAME TOP ASSEMBLY	3136-4	CONTRACTOR
1	4 METRE LEG ASSEMBLY	3136-5	CONTRACTOR
1	1.9 METRE HORIZONTAL BRACE ASSEMBLY	3136-6	CONTRACTOR
1	PLATFORM ASSEMBLY	3136-9	CONTRACTOR
1	CAR HOOK ASSEMBLY LEG	3136-10	CONTRACTOR
3	LADDER BRACKET ASSEMBLY	3136-13	CONTRACTOR
1	5m LADDER	3136-12	CONTRACTOR
1	HD LADDER GATE ASSEMBLY	3136-17	CONTRACTOR

A COMPLETE 5 METRE A-FRAME ASSEMBLY CONSISTS OF THE FOLLOWING:

QTY	DESCRIPTION	DWG No.	SUPPLIER
1	A-FRAME TOP ASSEMBLY	3136-4	CONTRACTOR
1	4 METRE LEG ASSEMBLY	3136-5	CONTRACTOR
1	1 METRE LEG ASSEMBLY	3136-5	CONTRACTOR
1	1.9 METRE HORIZONTAL BRACE ASSEMBLY	3136-6	CONTRACTOR
1	PLATFORM ASSEMBLY	3136-9	CONTRACTOR
1	CAR HOOK ASSEMBLY LEG	3136-10	CONTRACTOR
4	LADDER BRACKET ASSEMBLY	3136-13	CONTRACTOR
2	3m LADDER	3136-11	CONTRACTOR
1	HD LADDER GATE ASSEMBLY	3136-17	CONTRACTOR
4	1/2"-13 1-1/2" LG. ASTM A325M GALV. HEX BOLTS	-	CONTRACTOR
4	1/2"-13 ASTM A325M GALV. HEX NUTS	-	CONTRACTOR

A COMPLETE 1 METRE A-FRAME ASSEMBLY CONSISTS OF THE FOLLOWING:

QTY	DESCRIPTION	DWG No.	SUPPLIER
1	A-FRAME TOP ASSEMBLY	3136-4	CONTRACTOR
1	1 METRE LEG ASSEMBLY	3136-5	CONTRACTOR

EST. W.T. 173.4 kg

No.	Date	Revision	Dr	Ch
3	MAR/19	ADDED PLATFORM RAILING CLEARANCE NOTE	WC	BB
2	MAR/19	ISSUED FOR CONSTRUCTION	WC	BB
1	JUNE/02	APPROVED AND REDRAWN BY MCSL	KDW	AAW



McElhanney

McElhanney Consulting Services Ltd.

203-502 Bow Valley Trail, Canmore, AB, Canada T1W 1N9 Telephone 403-609-3992

This drawing is the property of McElhanney Consulting Services Ltd. and cannot be used or reprinted without the written consent of said company.

DEPT. OF THE ENVIRONMENT
WATER SURVEY OF CANADA, VANCOUVER, B.C.

HEAVY DUTY A-FRAMES
1, 2, 3, 4, & 5 METRE HEIGHTS

VANCOUVER, B.C.

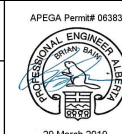

Designed D.O.E.
Drawn K.D.W.
Checked A.A.W.
Approved

Job No. 2111-01745-1
Scale 1:25
Date APRIL 2002
Revision 3

Drawing No.

3136-1

of 18

Destroy all prints bearing previous number.

BILLS OF MATERIAL

A COMPLETE 6 METRE A-FRAME ASSEMBLY CONSISTS OF THE FOLLOWING:

QTY	DESCRIPTION	DWG No.	SUPPLIER
1	A-FRAME TOP ASSEMBLY	3136-4	CONTRACTOR
1	4 METRE LEG ASSEMBLY	3136-5	CONTRACTOR
1	2 METRE LEG ASSEMBLY	3136-5	CONTRACTOR
1	1.9 METRE HORIZONTAL BRACE ASSEMBLY	3136-6	CONTRACTOR
1	2.7 METRE HORIZONTAL BRACE ASSEMBLY	3136-6	CONTRACTOR
1	PLATFORM ASSEMBLY	3136-9	CONTRACTOR
1	CAR HOOK ASSEMBLY LEG	3136-10	CONTRACTOR
4	LADDER BRACKET ASSEMBLY	3136-13	CONTRACTOR
1	3m LADDER	3136-11	CONTRACTOR
1	4m LADDER	3136-11	CONTRACTOR
1	HD LADDER GATE ASSEMBLY	3136-17	CONTRACTOR
4	1/2"-13 1-1/2"LG. ASTM A325M GALV. HEX BOLTS	-	CONTRACTOR
4	1/2"-13 ASTM A325M GALV. HEX NUTS	-	CONTRACTOR

A COMPLETE 7 METRE A-FRAME ASSEMBLY CONSISTS OF THE FOLLOWING:

QTY	DESCRIPTION	DWG No.	SUPPLIER
1	A-FRAME TOP ASSEMBLY	3136-4	CONTRACTOR
1	4 METRE LEG ASSEMBLY	3136-5	CONTRACTOR
1	3 METRE LEG ASSEMBLY	3136-5	CONTRACTOR
1	1.9 METRE HORIZONTAL BRACE ASSEMBLY	3136-6	CONTRACTOR
1	3.1 METRE HORIZONTAL BRACE ASSEMBLY	3136-6	CONTRACTOR
1	PLATFORM ASSEMBLY	3136-9	CONTRACTOR
1	CAR HOOK ASSEMBLY LEG	3136-10	CONTRACTOR
5	LADDER BRACKET ASSEMBLY	3136-13	CONTRACTOR
1	5m LADDER	3136-12	CONTRACTOR
1	3m LADDER	3136-11	CONTRACTOR
1	HD LADDER GATE ASSEMBLY	3136-17	CONTRACTOR
4	1/2"-13 1-1/2"LG. ASTM A325M GALV. HEX BOLTS	-	CONTRACTOR
4	1/2"-13 ASTM A325M GALV. HEX NUTS	-	CONTRACTOR

A COMPLETE 8 METRE A-FRAME ASSEMBLY CONSISTS OF THE FOLLOWING:

QTY	DESCRIPTION	DWG No.	SUPPLIER
1	A-FRAME TOP ASSEMBLY	3136-4	CONTRACTOR
2	4 METRE LEG ASSEMBLY	3136-5	CONTRACTOR
1	1.9 METRE HORIZONTAL BRACE ASSEMBLY	3136-6	CONTRACTOR
1	3.5 METRE HORIZONTAL BRACE ASSEMBLY	3136-6	CONTRACTOR
1	PLATFORM ASSEMBLY	3136-9	CONTRACTOR
1	CAR HOOK ASSEMBLY LEG	3136-10	CONTRACTOR
5	LADDER BRACKET ASSEMBLY	3136-13	CONTRACTOR
1	4m LADDER	3136-11	CONTRACTOR
1	5m LADDER	3136-12	CONTRACTOR
1	TOP LADDER CAGE	3136-14	CONTRACTOR
1	SHORT FLARE LADDER CAGE	3136-15	CONTRACTOR
1	HD LADDER GATE ASSEMBLY	3136-17	CONTRACTOR
4	1/2"-13 1-1/2"LG. ASTM A325M GALV. HEX BOLTS	-	CONTRACTOR
4	1/2"-13 ASTM A325M GALV. HEX NUTS	-	CONTRACTOR

ALL DIMENSIONS IN MILLIMETRES UNLESS OTHERWISE NOTED

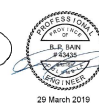

29 March 2019

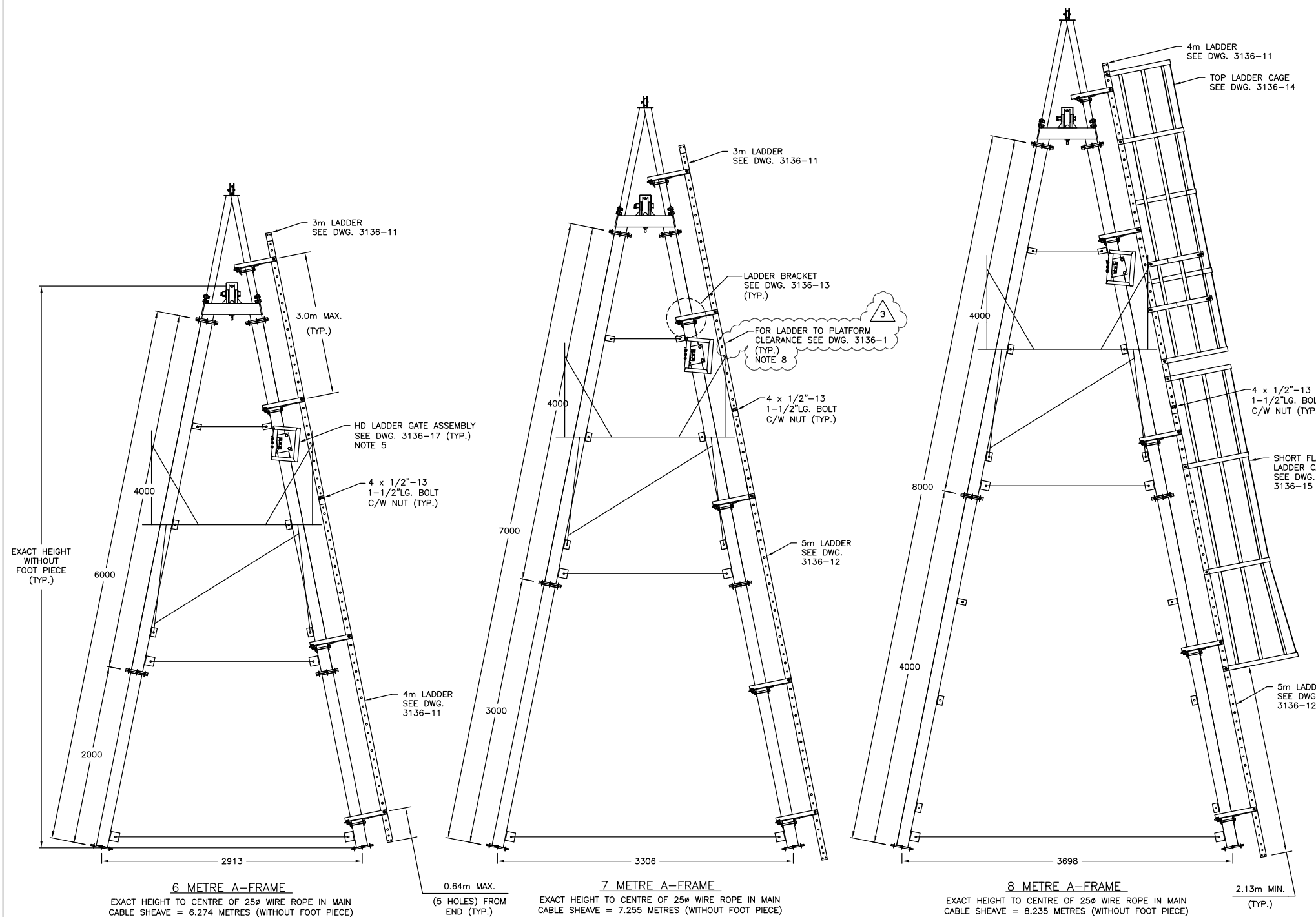

NOTES:

1. ALL PARTS TO BE HOT-DIPPED GALVANIZED AS PER ASTM A123/A123M.
2. ALL BOLTS & NUTS TO BE M16 A325M TYPE 2 GALVANIZED, UNLESS OTHERWISE NOTED.
3. ALL STEEL SHALL CONFORM TO C.S.A. G40.21M GRADE 350W GALVANIZED, UNLESS OTHERWISE NOTED.
4. LADDER BRACKET SPACING; 3.0m MAX. AND 0.64m MAX. (5 HOLES) FROM ENDS.
5. HD LADDER GATE ASSEMBLY TO BE INSTALLED SO TOP OF GATE IS LEVEL WITH TOP OF PLATFORM RAILING.
6. LADDERS ARE DESIGNED TO MEET ANSI14.3-2008 REQUIREMENTS.
7. LADDER TO BE OCCUPIED BY MAX. 1 PERSONS AT ANY GIVEN TIME.
8. FIELD MODIFY EXISTING PLATFORM RAILING TO CLEARANCE OF 457mm MIN.-475mm MAX. FROM BACK OF RAILING TO O/S LADDER SIDE RAIL.

DESIGN LOAD	
CAR	200
2 MEN	400
REEL	50
	650 lbs.
PLUS SNAG LOAD OF 1/8" WIRE ROPE AT ANY ANGLE = 1600 lbs. BREAKING STRENGTH.	

No.	Date	Revision	Dr	Ch
3	MAR/19	ADDED PLATFORM RAILING CLEARANCE NOTE	WC	BB
2	MAR/19	ISSUED FOR CONSTRUCTION	WC	BB
1	JUNE/02	APPROVED AND REDRAWN BY MCSL	KDW	AAW



McElhanney

McElhanney Consulting Services Ltd.

203-502 Bow Valley Trail, Canmore, AB, Canada T1W 1N9 Telephone 403-609-3992

This drawing is the property of McElhanney Consulting Services Ltd. and cannot be used or reprinted without the written consent of said company.

DEPT. OF THE ENVIRONMENT
WATER SURVEY OF CANADA, VANCOUVER, B.C.

HEAVY DUTY A-FRAMES
6, 7, & 8 METRES

VANCOUVER, B.C.

APEGA Permit# 06383



29 March 2019

Designed D.O.E.

Drawn K.D.W.

Checked A.A.W.

Approved

Job No. 2111-01745-1

Scale 1:25

Date APRIL 2002

Revision 3

Drawing No.

3136-2

of 18

Destroy all prints bearing previous number.

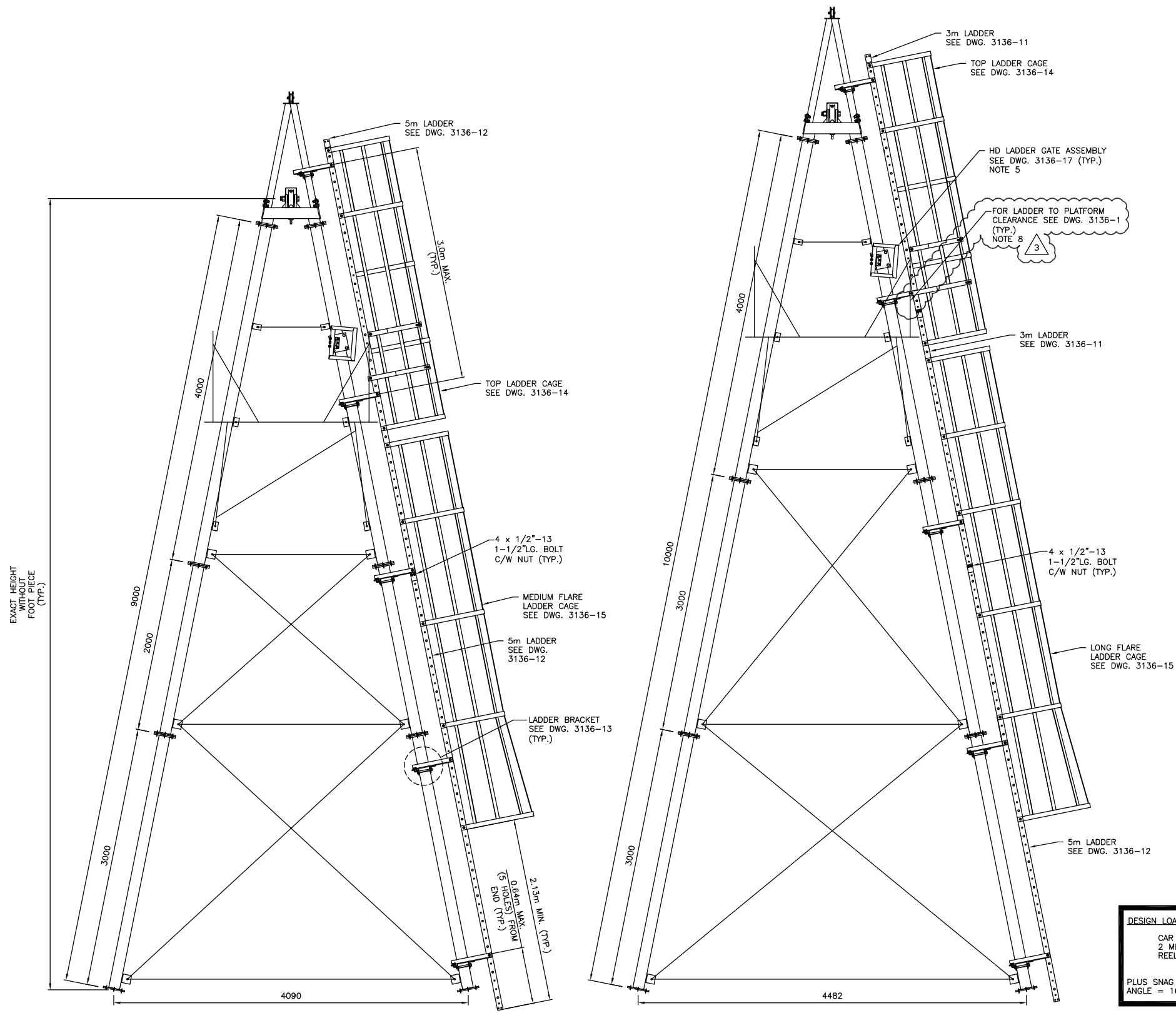

EXACT HEIGHT WITHOUT FOOT PIECE (TYP.)

9 METRE A-FRAME
EXACT HEIGHT TO CENTRE OF 25Ø WIRE ROPE IN MAIN CABLE SHEAVE = 9.216 METRES (WITHOUT FOOT PIECE)

10 METRE A-FRAME
EXACT HEIGHT TO CENTRE OF 25Ø WIRE ROPE IN MAIN CABLE SHEAVE = 10.197 METRES (WITHOUT FOOT PIECE)

DESIGN LOAD	
CAR	200
2 MEN	400
REEL	50
	650 lbs.

PLUS SNAG LOAD OF 1/8" WIRE ROPE AT ANY ANGLE = 1600 lbs. BREAKING STRENGTH.

ALL DIMENSIONS IN MILLIMETRES UNLESS OTHERWISE NOTED



BILLS OF MATERIAL

A COMPLETE 9 METRE A-FRAME ASSEMBLY CONSISTS OF THE FOLLOWING:

QTY	DESCRIPTION	DWG No.	SUPPLIER
1	A-FRAME TOP ASSEMBLY	3136-4	CONTRACTOR
1	4 METRE LEG ASSEMBLY	3136-5	CONTRACTOR
1	2 METRE LEG ASSEMBLY	3136-5	CONTRACTOR
1	3 METRE LEG ASSEMBLY	3136-5	CONTRACTOR
1	1.9 METRE HORIZONTAL BRACE ASSEMBLY	3136-6	CONTRACTOR
1	2.7 METRE HORIZONTAL BRACE ASSEMBLY	3136-6	CONTRACTOR
1	3.9 METRE HORIZONTAL BRACE ASSEMBLY	3136-6	CONTRACTOR
1	LATERAL BRACING ASSEMBLY FOR 9 METRE A-FRAME	3136-6	CONTRACTOR
1	PLATFORM ASSEMBLY	3136-9	CONTRACTOR
1	CAR HOOK ASSEMBLY LEG	3136-10	CONTRACTOR
5	LADDER BRACKET ASSEMBLY	3136-13	CONTRACTOR
2	5m LADDER	3136-12	CONTRACTOR
1	TOP LADDER CAGE	3136-14	CONTRACTOR
1	MEDIUM FLARE LADDER CAGE	3136-15	CONTRACTOR
1	HD LADDER GATE ASSEMBLY	3136-17	CONTRACTOR
4	1/2"-13 1-1/2"LG. ASTM A325M GALV. HEX BOLTS	-	CONTRACTOR
4	1/2"-13 ASTM A325M GALV. HEX NUTS	-	CONTRACTOR

A COMPLETE 10 METRE A-FRAME ASSEMBLY CONSISTS OF THE FOLLOWING:

QTY	DESCRIPTION	DWG No.	SUPPLIER
1	A-FRAME TOP ASSEMBLY	3136-4	CONTRACTOR
1	4 METRE LEG ASSEMBLY	3136-5	CONTRACTOR
2	3 METRE LEG ASSEMBLY	3136-5	CONTRACTOR
1	1.9 METRE HORIZONTAL BRACE ASSEMBLY	3136-6	CONTRACTOR
1	3.1 METRE HORIZONTAL BRACE ASSEMBLY	3136-6	CONTRACTOR
1	4.2 METRE HORIZONTAL BRACE ASSEMBLY	3136-6	CONTRACTOR
1	LATERAL BRACING ASSEMBLY FOR 10 METRE A-FRAME	3136-6	CONTRACTOR
1	PLATFORM ASSEMBLY	3136-9	CONTRACTOR
1	CAR HOOK ASSEMBLY LEG	3136-10	CONTRACTOR
5	LADDER BRACKET ASSEMBLY	3136-13	CONTRACTOR
1	5m LADDER	3136-12	CONTRACTOR
2	3m LADDER	3136-11	CONTRACTOR
1	TOP LADDER CAGE	3136-14	CONTRACTOR
1	LONG FLARE LADDER CAGE	3136-15	CONTRACTOR
1	HD LADDER GATE ASSEMBLY	3136-17	CONTRACTOR
8	1/2"-13 1-1/2"LG. ASTM A325M GALV. HEX BOLTS	-	CONTRACTOR
8	1/2"-13 ASTM A325M GALV. HEX NUTS	-	CONTRACTOR

- NOTES:**
- ALL PARTS TO BE HOT-DIPPED GALVANIZED AS PER ASTM A123/A123M.
 - ALL BOLTS & NUTS TO BE M16 A325M TYPE 2 GALVANIZED, UNLESS OTHERWISE NOTED.
 - ALL STEEL SHALL CONFORM TO C.S.A. G40.21M GRADE 350W GALVANIZED, UNLESS OTHERWISE NOTED.
 - LADDER BRACKET SPACING; 3.0m MAX. AND 0.64m MAX. (5 HOLES) FROM ENDS.
 - HD LADDER GATE ASSEMBLY TO BE INSTALLED SO TOP OF GATE IS LEVEL WITH TOP OF PLATFORM RAILING.
 - LADDERS ARE DESIGNED TO MEET ANSI14.3-2008 REQUIREMENTS.
 - LADDER TO BE OCCUPIED BY MAX. 1 PERSONS AT ANY GIVEN TIME.
 - FIELD MODIFY EXISTING PLATFORM RAILING TO CLEARANCE OF 457mm MIN.-475mm MAX. FROM BACK OF RAILING TO O/S LADDER SIDE RAIL.

APRIL 26, 2002 M3111-01745-1 (REVISED) 1/25-SCALE

No.	Date	Revision	Dr	Ch
3	MAR/19	ADDED PLATFORM RAILING CLEARANCE NOTE	WC	BB
2	MAR/19	ISSUED FOR CONSTRUCTION	WC	BB
1	JUNE/02	APPROVED AND REDRAWN BY MCSL	KDW	AAW

McElhanney
McElhanney Consulting Services Ltd.
203-502 Bow Valley Trail, Canmore, AB, Canada T1W 1N9 Telephone 403-609-3992
This drawing is the property of McElhanney Consulting Services Ltd. and cannot be used or reprinted without the written consent of said company.

DEPT. OF THE ENVIRONMENT
WATER SURVEY OF CANADA, VANCOUVER, B.C.
HEAVY DUTY A-FRAMES
9 & 10 METRES
VANCOUVER, B.C.

Designed D.O.E.	Job No. 2111-01745-1	Drawing No.
Drawn K.D.W.	Scale 1:25	3136-3
Checked A.A.W.	Date APRIL 2002	
Approved	Revision 3	of 18

Destroy all prints bearing previous number.

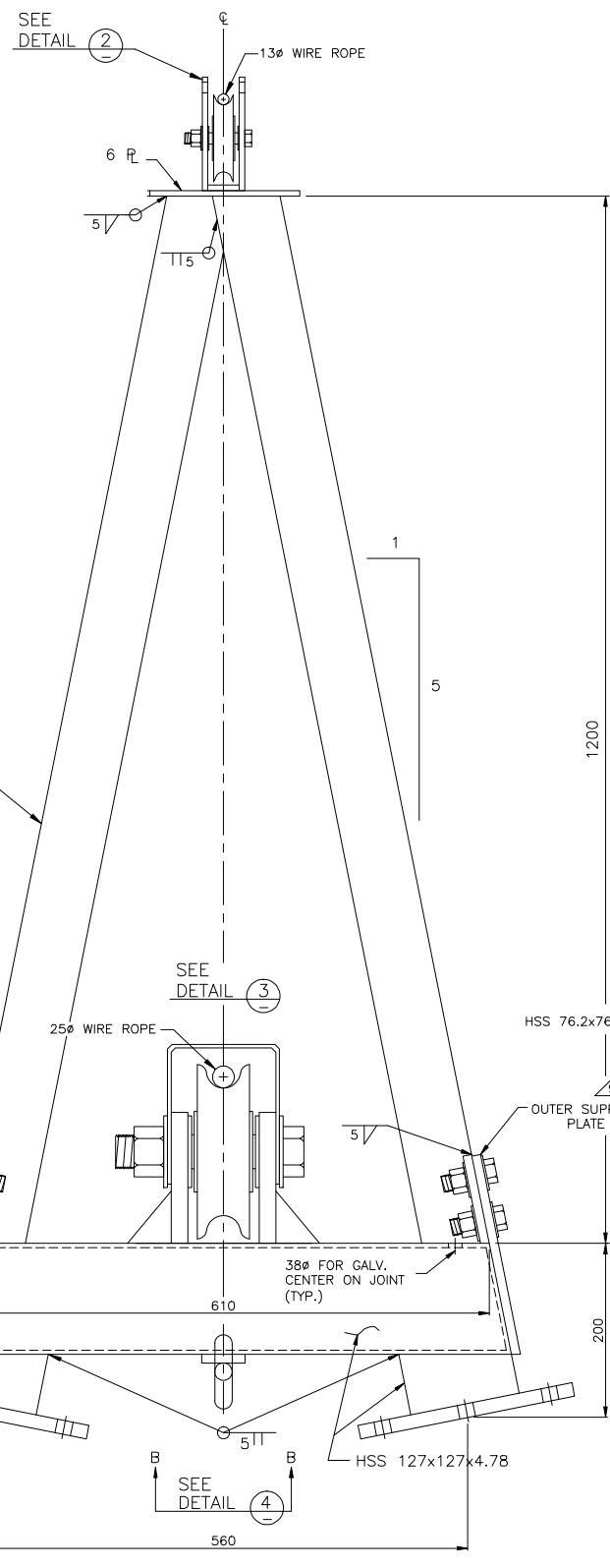

FRONT VIEW
A-FRAME TOP
SCALE 1:4

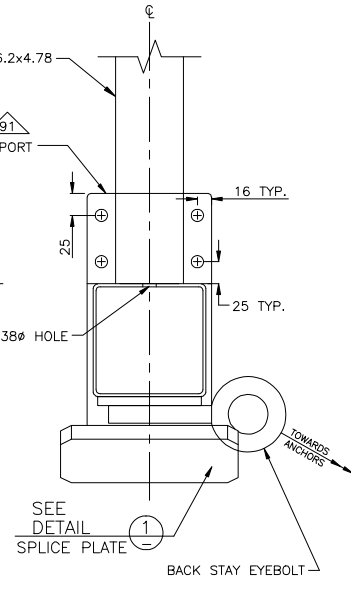

SIDE VIEW
A-FRAME TOP

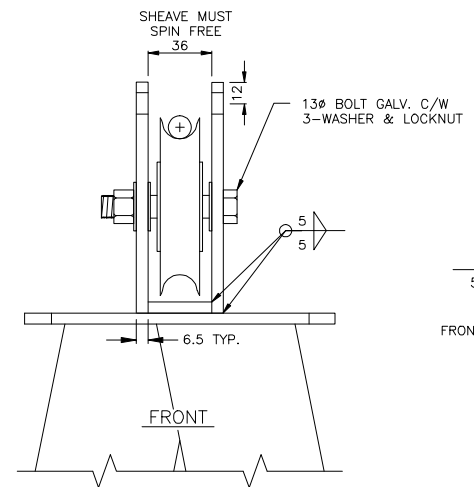

DETAIL 2
SCALE: 1:2
AIRCRAFT MARKER CABLE
SHEAVE BRACKET

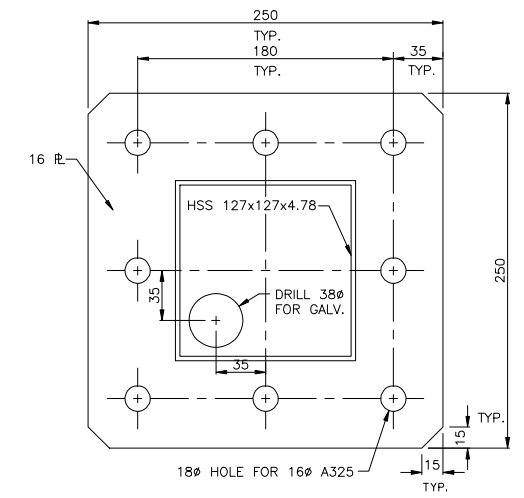
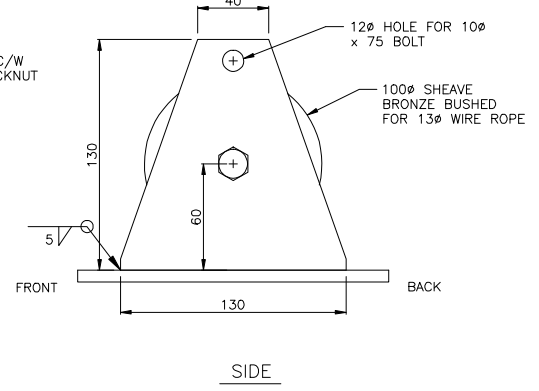

DETAIL 1
SCALE: 1:2.5
SPLICE PLATE

BILL OF MATERIAL

A COMPLETE A-FRAME TOP ASSEMBLY
CONSISTS OF THE FOLLOWING:

QTY	DESCRIPTION	DWG No.	SUPPLIER
1	A-FRAME TOP (2-pc)	3136-4	FABRICATOR
16	A325M TYPE 2 GALV. M16X60 c/w NUT & WASHER		FABRICATOR
8	M12x1.75x38 (AS ABOVE) STRUCTURAL BOLT		FABRICATOR

- NOTES:**
- 1) ALL PARTS TO BE HOT DIPPED GALVANIZED.
 - 2) ALL BOLTS & NUTS TO BE M16 A325M, UNLESS NOTED OTHERWISE.
 - 3) ALL STEEL SHALL CONFORM TO CSA G.40.21M GRADE 350W.
 - 4) THE MARKER LINE A-FRAME SUPPORT IS ATTACHED IN THE FIELD BUT SHOULD BE BRACED WITH WOOD DURING SHIPPING TO PREVENT DAMAGE.

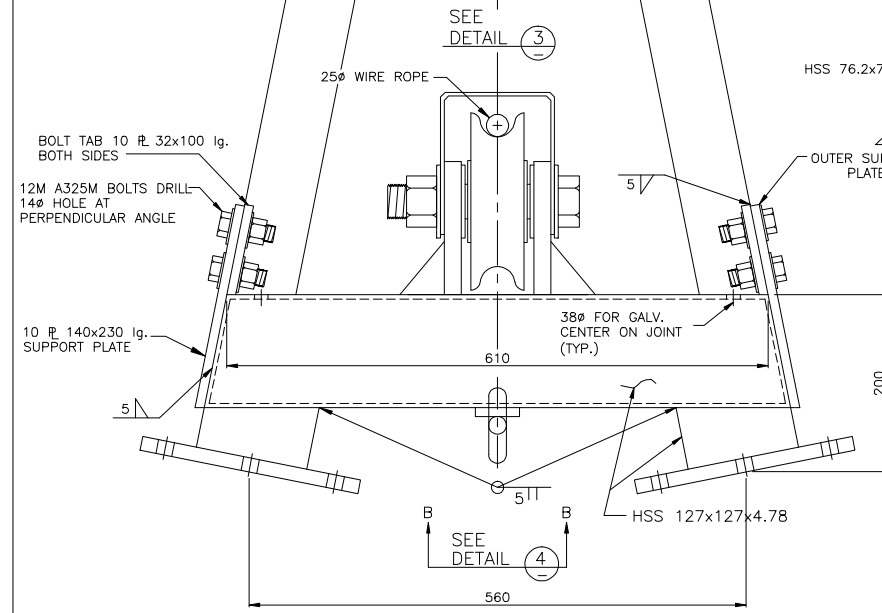

ALL DIMENSIONS IN MILLIMETRES
UNLESS OTHERWISE NOTED

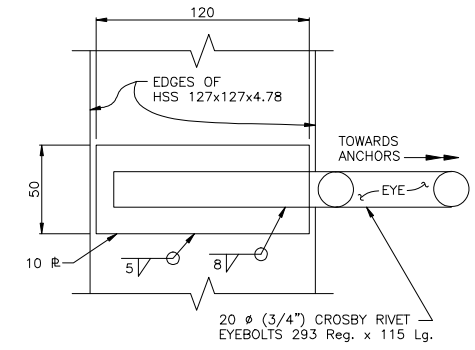

DETAIL 4
SCALE: 1:2
BACK STAY EYEBOLT
SECTION B-B

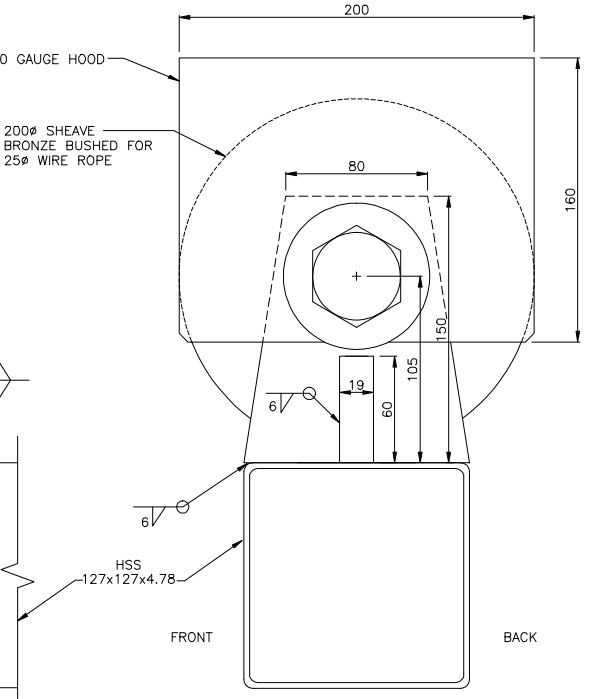
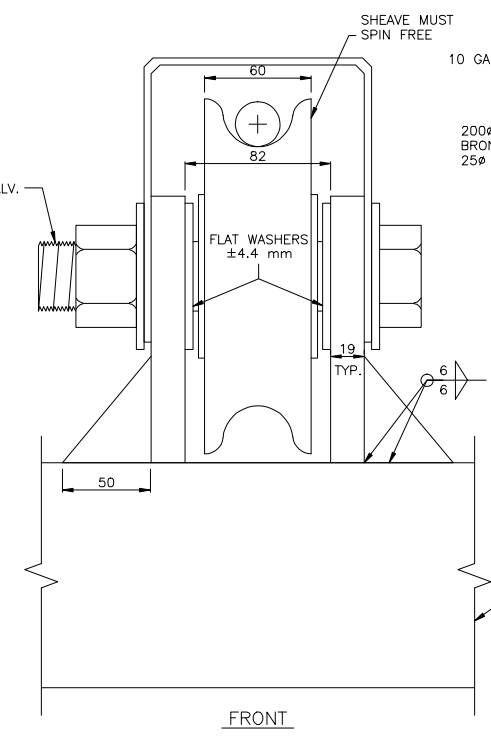

DETAIL 3
SCALE: 1:2
MAINCABLE SHEAVE BRACKET

No.	Date	Revision	Dr	Ch
1	JUNE/02	APPROVED AND REDRAWN BY MCSL	KDW	AWW



McElhanney
 McElhanney Consulting Services Ltd.
 13160-88 Ave., Surrey, B.C., Canada V3W 3K3 Telephone (604)596-0391
This drawing is the property of McElhanney Consulting Services Ltd. and cannot be used or reproduced without the written consent of said company.

DEPT. OF THE ENVIRONMENT
 WATER SURVEY OF CANADA, VANCOUVER, B.C.
 HEAVY DUTY A-FRAMES
 VARIOUS DETAILS, TOP ASSEMBLY
 VANCOUVER, B.C.

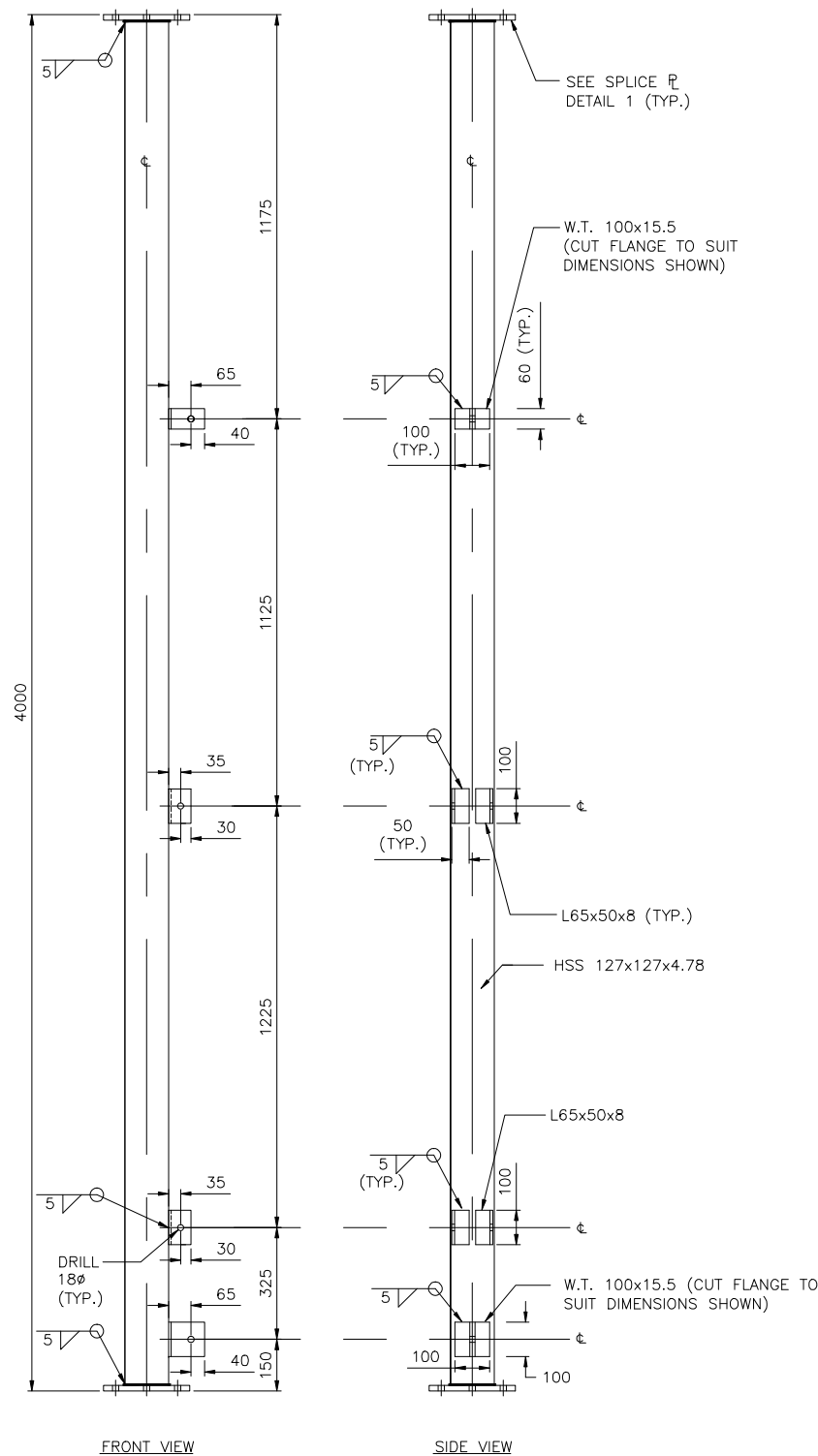
Designed	D.O.E.	Job No.	2111-01745-1	Drawing No.
Drawn	K.D.W.	Scale	AS SHOWN	3136-4
Checked	A.A.W.	Date	APRIL 2002	
Approved		Revision	1	of 10

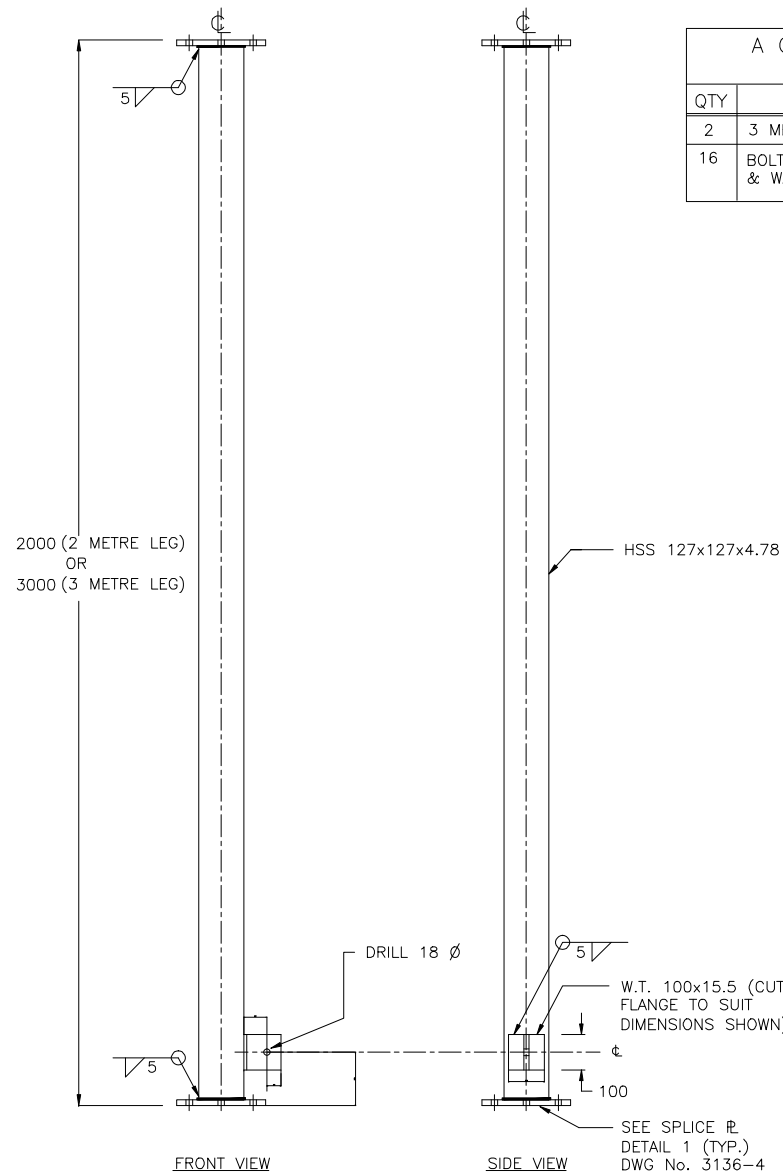

4 METRE LEG
SCALE 1:12



3 AND 2 METRE LEG ASSEMBLY (2 LEGS TO AN ASSEMBLY)
SCALE 1:10

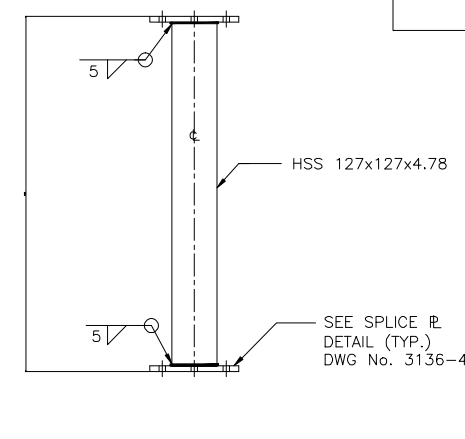

1 METRE LEG ASSEMBLY (2 LEGS TO AN ASSEMBLY)
SCALE 1:10

BILLS OF MATERIAL

A COMPLETE 4 METRE LEG ASSEMBLY CONSISTS OF THE FOLLOWING:

QTY	DESCRIPTION	DWG No.	SUPPLIER
2	4 METRE LEG	3136-5	FABRICATOR
16	BOLTS M16x60 A325 c/w NUT & WASHER		FABRICATOR

EST. W.T. 187.4 KG

A COMPLETE 2 METRE LEG ASSEMBLY CONSISTS OF THE FOLLOWING:

QTY	DESCRIPTION	DWG No.	SUPPLIER
2	2 METRE LEG	3136-5	FABRICATOR
16	BOLTS M16x60 A325 c/w NUT & WASHER		FABRICATOR

EST. W.T. 101.5 KG

A COMPLETE 3 METRE LEG ASSEMBLY CONSISTS OF THE FOLLOWING:

QTY	DESCRIPTION	DWG No.	SUPPLIER
2	3 METRE LEG	3136-5	FABRICATOR
16	BOLTS M16x60 A325 c/w NUT & WASHER		FABRICATOR

EST. W.T. 144.7 KG

A COMPLETE 1 METRE LEG ASSEMBLY CONSISTS OF THE FOLLOWING:

QTY	DESCRIPTION	DWG No.	SUPPLIER
2	1 METRE LEG	3136-5	FABRICATOR
16	BOLTS M16x60 A325 c/w NUT & WASHER		FABRICATOR

EST. W.T. 70.6 KG

NOTES:

1. ALL PARTS TO BE HOT-DIPPED GALVANIZED
2. ALL BOLTS & NUTS TO BE A325M TYPE 2 GALVANIZED, UNLESS NOTED OTHERWISE
3. ALL STEEL SHALL CONFORM TO C.S.A. G.40.21M GRADE 350W.

* ALL LEG ASSEMBLIES ARE TO BE MADE UP OF A SINGLE PIECE OF HSS 127x127x4.78, NO WELDED JOINT.

ALL DIMENSIONS IN MILLIMETRES UNLESS OTHERWISE NOTED

M:\PROJ\2111-01745-1\DRAWINGS\3136-5.DWG

JUN 27 2002

No.	Date	Revision	Dr	Ch
1	JUNE/02	APPROVED AND REDRAWN BY MCSL	KDW	AAW



McElhanney

McElhanney Consulting Services Ltd.
13160-88 Ave., Surrey, B.C., Canada V3W 3K3 Telephone (604)596-0391

This drawing is the property of McElhanney Consulting Services Ltd. and cannot be used or reprinted without the written consent of said company.

DEPT. OF THE ENVIRONMENT
WATER SURVEY OF CANADA, VANCOUVER, B.C.

HEAVY DUTY A-FRAMES
VARIOUS DETAILS, LEG ASSEMBLY

VANCOUVER, B.C.

Designed	D.O.E.	Job No.	2111-01745-1	Drawing No.
Drawn	K.D.W.	Scale	AS SHOWN	3136-5
Checked	A.A.W.	Date	APRIL 2002	
Approved		Revision	1	

of 10

Destroy all prints bearing previous number

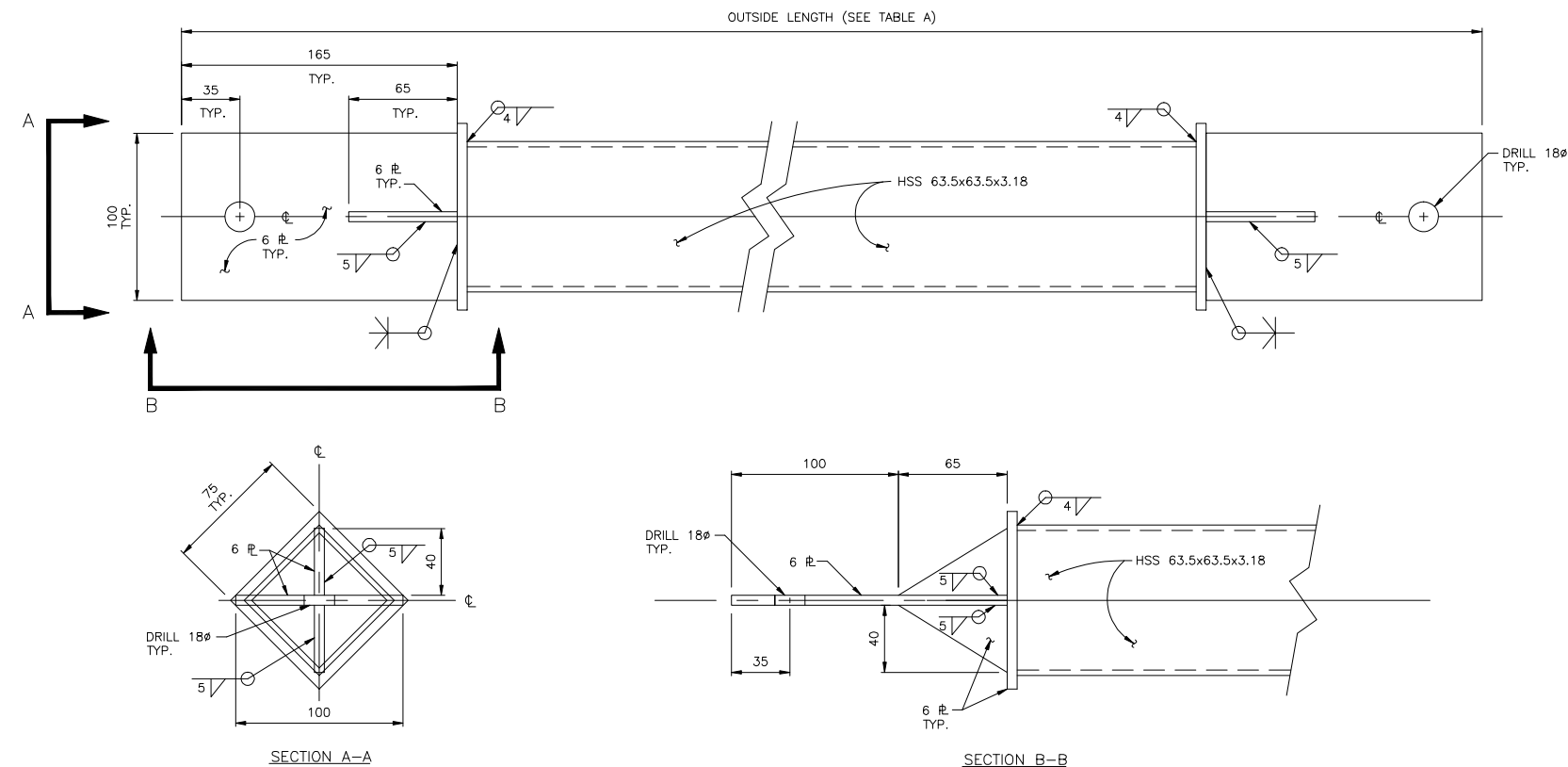

HORIZONTAL BRACE

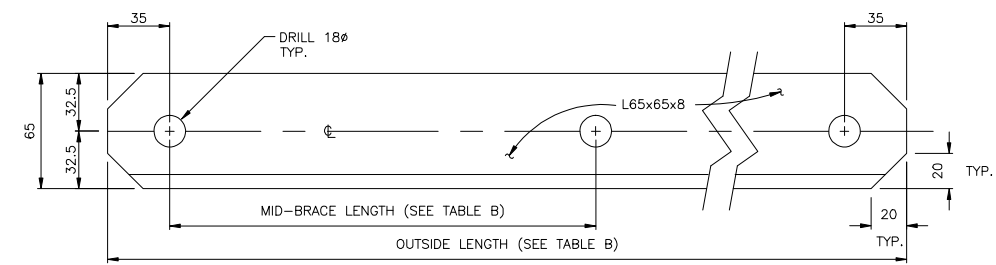

LATERAL BRACE

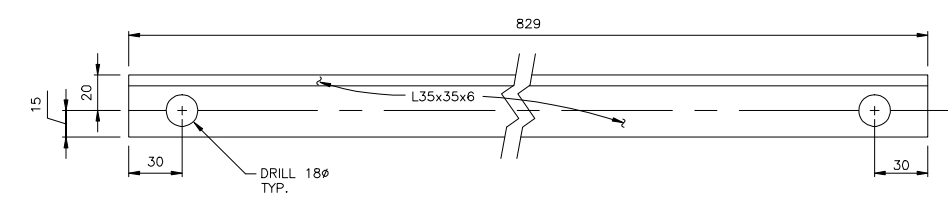

SAFETY RAIL (SEE ALSO DWG 3136-9)
EST. WT. 4.9 kg

TABLE A

NOMINAL LENGTH OF HORIZONTAL BRACE	OUTSIDE LENGTH IN MILLIMETRES	EST. WT. & BOLTS
1.1 METRE	1104	7.3 kg
1.5 METRE	1496	9.6 kg
1.9 METRE	1888	11.9 kg
2.7 METRE	2673	16.5 kg
3.1 METRE	3065	18.7 kg
3.5 METRE	3457	21.0 kg
3.9 METRE	3849	23.3 kg
4.2 METRE	4241	25.6 kg

TABLE B

NOMINAL LENGTH OF LATERAL BRACE	MID-BRACE LENGTH IN MILLIMETRES	OUTSIDE LENGTH IN MILLIMETRES	EST. WT. (kg)
3.0 METRE	1740	3025	17.5
4.4 METRE	2570	4410	25.7
3.9 METRE	2365	3871	22.5
4.7 METRE	2699	4706	27.5

BILLS OF MATERIAL

A COMPLETE HORIZONTAL BRACE ASSEMBLY CONSISTS OF THE FOLLOWING:

QTY	DESCRIPTION	DWG No.	SUPPLIER
1	HORIZONTAL BRACE OF VARIOUS NOMINAL LENGTHS (SEE TABLE A)	3136-6	FABRICATOR
2	BOLT M16x45, C/W NUT & WASHER		FABRICATOR

A COMPLETE LATERAL BRACING ASSEMBLY FOR A 9 METRE A-FRAME CONSISTS OF:

QTY	DESCRIPTION	DWG No.	SUPPLIER
2	3 METRE LATERAL BRACE (SEE TABLE B)	3136-6	FABRICATOR
2	4.4 METRE LATERAL BRACE (SEE TABLE B)	3136-6	FABRICATOR
2	BOLTS M16x50, C/W NUT & WASHER		FABRICATOR

EST. W.T. 86.9 kg

A COMPLETE LATERAL BRACING ASSEMBLY FOR A 10 METRE A-FRAME CONSISTS OF:

QTY	DESCRIPTION	DWG No.	SUPPLIER
2	3.9 METRE LATERAL BRACE (SEE TABLE B)	3136-6	FABRICATOR
2	4.7 METRE LATERAL BRACE (SEE TABLE B)	3136-6	FABRICATOR
2	BOLTS M16x50, C/W NUT & WASHER		FABRICATOR

EST. W.T. 100.5 kg

NOTES:

- ALL PARTS TO BE HOT-DIPPED GALVANIZED C.S.A. G-164
- ALL BOLTS & NUTS TO BE A325M TYPE2 GALVANIZED, UNLESS NOTED OTHERWISE
- ALL STEEL SHALL CONFORM TO C.S.A. G. 40.21M GRADE 350W.

ALL DIMENSIONS IN MILLIMETRES UNLESS OTHERWISE NOTED

No.	Date	Revision	Dr	Ch
1	JUNE/02	APPROVED AND REDRAWN BY MCSL	KDW	AAW



McElhanney
McElhanney Consulting Services Ltd.
13160-88 Ave., Surrey, B.C., Canada V3W 3K3 Telephone (604)596-0391
This drawing is the property of McElhanney Consulting Services Ltd. and cannot be used or reprinted without the written consent of said company.

DEPT. OF THE ENVIRONMENT
WATER SURVEY OF CANADA, VANCOUVER, B.C.
HEAVY DUTY A-FRAMES
VARIOUS DETAILS, HORIZONTAL BRACE ASSEMBLY LATERAL BRACING ASSEMBLY SAFETY RAIL
VANCOUVER, B.C.

Designed	D.O.E.	Job No.	2111-01745-1	Drawing No.
Drawn	K.D.W.	Scale	AS SHOWN	3136-6
Checked	A.A.W.	Date	APRIL 2002	
Approved		Revision	1	

BRACED PLATE STEEL FOOTINGS

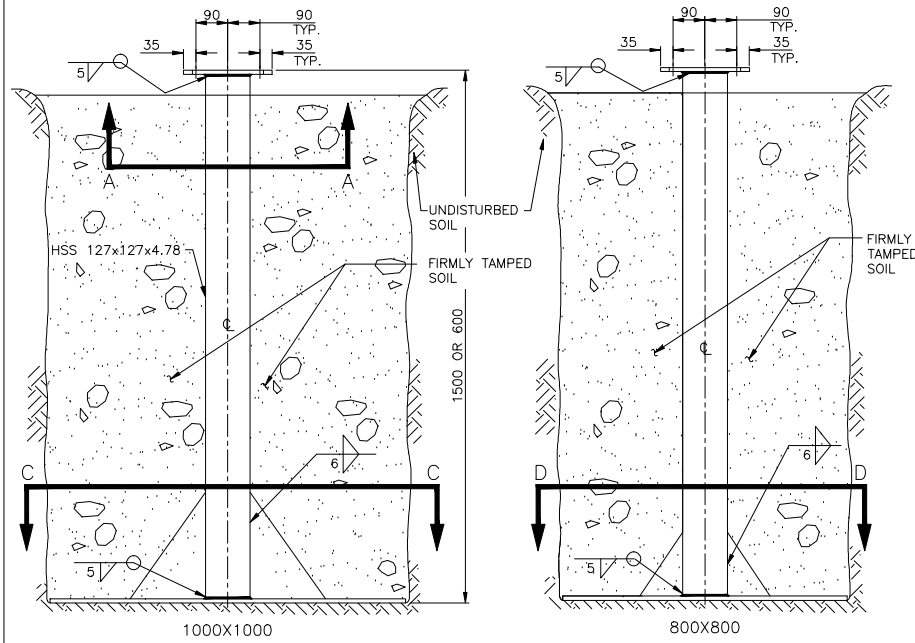

BRACED PLATE STEEL FOOTINGS
SCALE 1:10

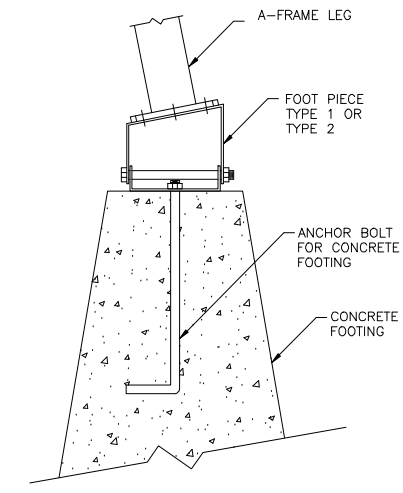

CONCRETE FOOTING ARRANGEMENT
SCALE 1:10

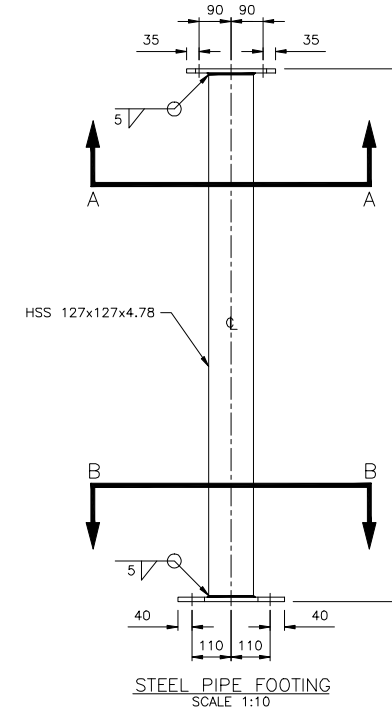

STEEL PIPE FOOTING
SCALE 1:10

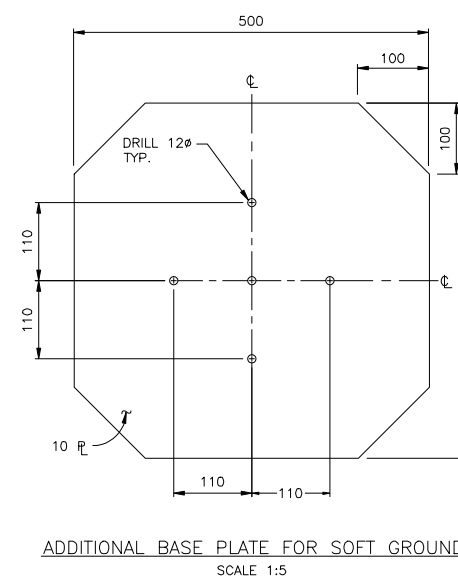

ADDITIONAL BASE PLATE FOR SOFT GROUND
SCALE 1:5

BILLS OF MATERIAL

A COMPLETE PIPE FOOTING ASSEMBLY
CONSISTS OF THE FOLLOWING:

QTY	DESCRIPTION	DWG No.	SUPPLIER
1	STEEL PIPE FOOTING	3136-7	FABRICATOR
4	BOLTS 16MX60 C/W NUT & WASHER		FABRICATOR

EST. W.T. 40.8 kg

A COMPLETE ADDITIONAL BASE FOR SOFT
GROUND CONSISTS OF THE FOLLOWING:

QTY	DESCRIPTION	DWG No.	SUPPLIER
1	ADDITIONAL BASE PLATE FOR SOFT GROUND	3136-7	FABRICATOR
4	M10 HOT-DIPPED GALVANIZED BOLT C/W NUT & WASHER		FABRICATOR

EST. W.T. 18.2 kg

A COMPLETE ANCHOR BOLT FOR CONCRETE
FOOTING CONSISTS OF THE FOLLOWING:

QTY	DESCRIPTION	DWG No.	SUPPLIER
1	ANCHOR BOLT FOR CONCRETE FOOTING C/W NUT & WASHERS	3136-7	FABRICATOR

EST. W.T. 3.1 kg

A COMPLETE BRACED PLATE STEEL
FOOTING CONSISTS OF THE FOLLOWING:

QTY	DESCRIPTION	DWG No.	SUPPLIER
1	STEEL PIPE FOOTING SPECIFY LENGTH & FOOTING SIZE	3136-7	FABRICATOR
4	BOLTS 16MX60 C/W NUT & WASHER		FABRICATOR

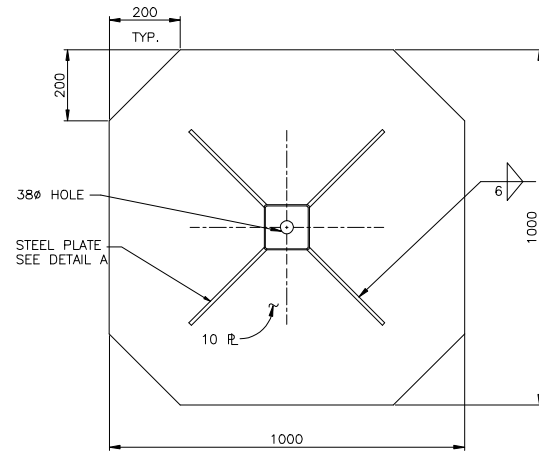

SECTION C-C
BASE PLATE
SCALE 1:10

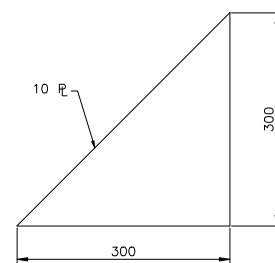

STEEL PLATE A
SCALE 1:20

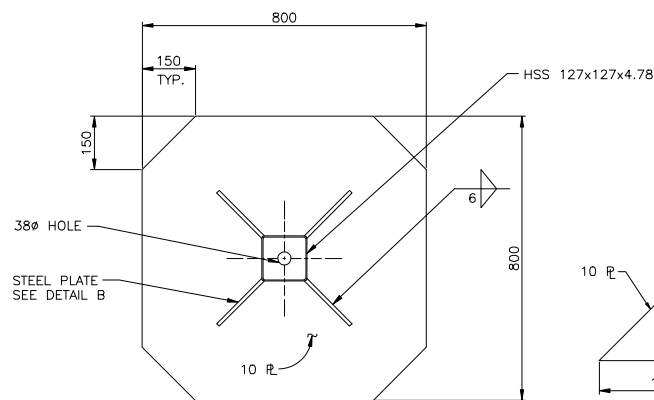

SECTION D-D
BASE PLATE
SCALE 1:10

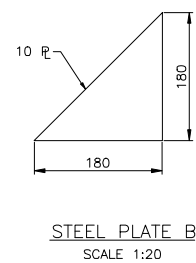

STEEL PLATE B
SCALE 1:20

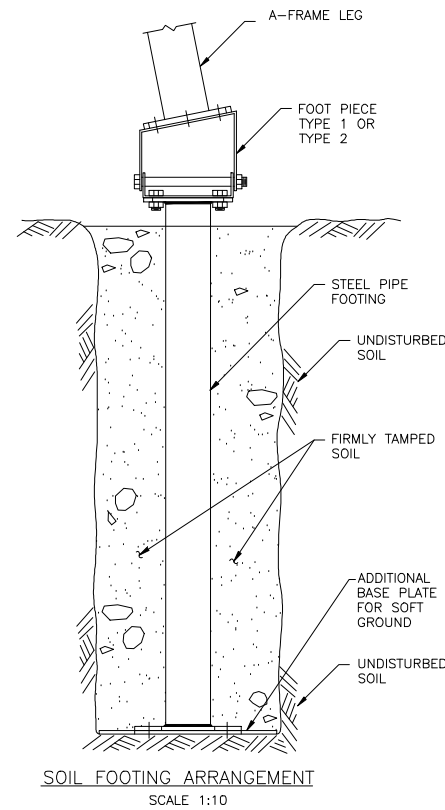

SOIL FOOTING ARRANGEMENT
SCALE 1:10

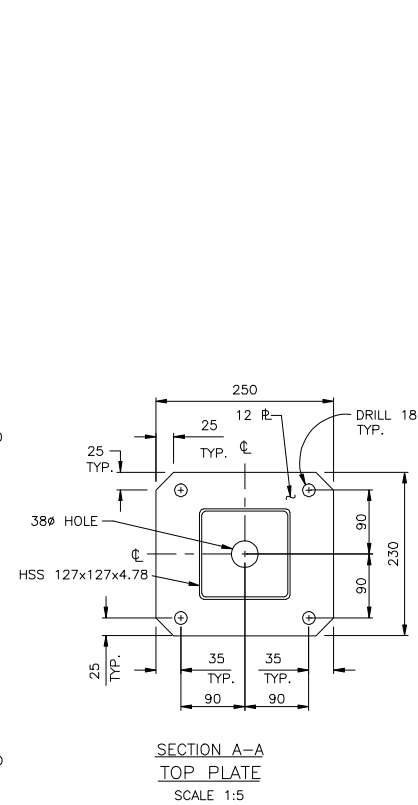

SECTION A-A
TOP PLATE
SCALE 1:5

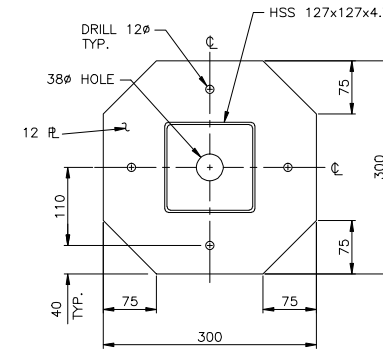

SECTION B-B
BASE PLATE
SCALE 1:5

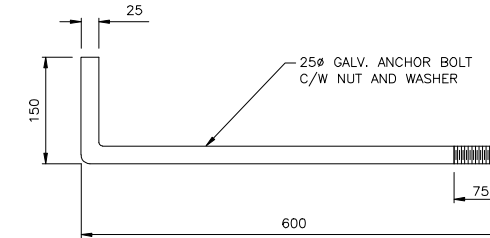

ANCHOR BOLT FOR CONCRETE FOOTING
SCALE 1:5

- NOTES:
1. ALL PARTS TO BE HOT-DIPPED GALVANIZED AS PER C.S.A. G-164
 2. ALL BOLTS & NUTS TO BE M16 A325M TYPE 2 GALVANIZED, UNLESS NOTED OTHERWISE
 3. ALL STEEL SHALL CONFORM TO C.S.A. G40.21M GRADE 350W.

No.	Date	Revision	Dr	Ch
1	JUNE/02	APPROVED AND REDRAWN BY MCSL	KDW	AAW



McElhanney

McElhanney Consulting Services Ltd.
13160-88 Ave., Surrey, B.C., Canada V3W 3K3 Telephone (604)596-0391
This drawing is the property of McElhanney Consulting Services Ltd. and cannot be used or reproduced without the written consent of said company.

DEPT. OF THE ENVIRONMENT
WATER SURVEY OF CANADA, VANCOUVER, B.C.

HEAVY DUTY A-FRAMES
VARIOUS FOOTING TYPES

VANCOUVER, B.C.

Designed	D.O.E.	Job No.	2111-01745-1	Drawing No.
Drawn	K.D.W.	Scale	AS SHOWN	3136-7
Checked	A.A.W.	Date	APRIL 2002	
Approved		Revision	1	of 10

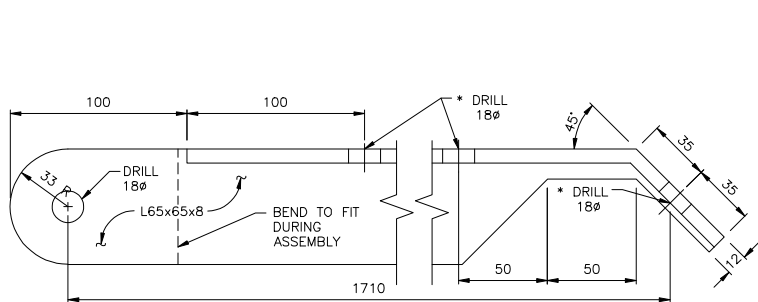

VERTICAL SUPPORT: DETAIL 3
(L.H. SIDE SHOWN) SCALE 1:2

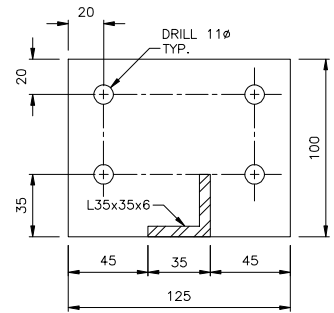

HANDRAIL UNIT: DETAIL 5
SCALE 1:2

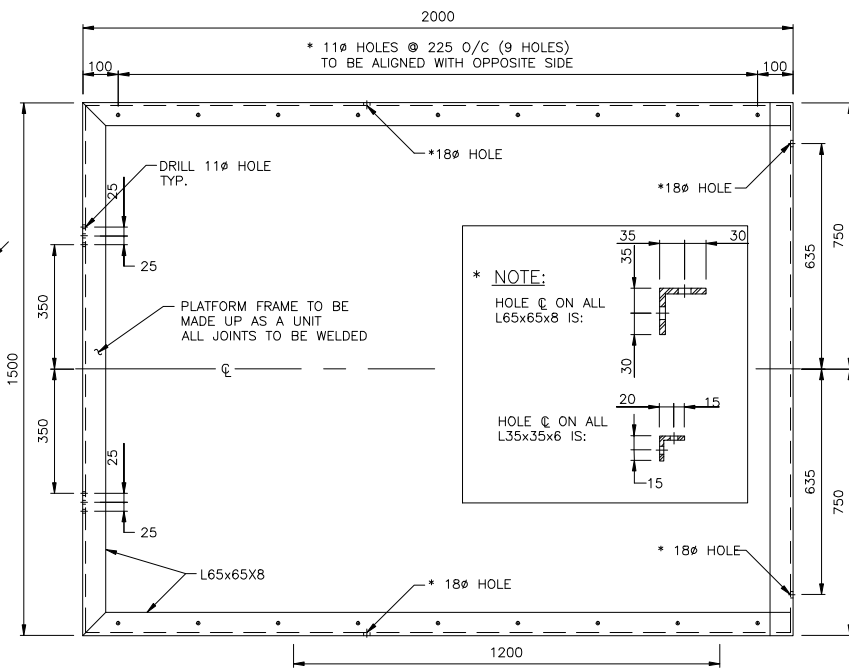

PLATFORM FRAME: DETAIL 2
SCALE 1:10

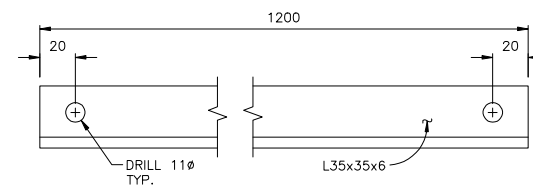

HANDRAIL BRACES: DETAIL 4
SCALE 1:2

BILLS OF MATERIAL

A COMPLETE PLATFORM ASSEMBLY CONSISTS OF THE FOLLOWING:

QTY	DESCRIPTION	DWG No.	SUPPLIER
1	PLATFORM FRAME	3136-9	FABRICATOR
2	HANDRAIL UNIT	3136-9	FABRICATOR
2	HANDRAIL BRACES	3136-9	FABRICATOR
1	VERTICAL SUPPORT, L.H. SIDE	3136-9	FABRICATOR
1	VERTICAL SUPPORT, R.H. SIDE	3136-9	FABRICATOR
1	LATERAL BRACE	3136-9	FABRICATOR
1	SAFETY RAIL	3136-6	FABRICATOR
12	BOLTS M16x45 C/W NUT & WASHER		FABRICATOR
20	M10x125 LONG GALVANIZED BOLT C/W NUT & WASHER		FABRICATOR
6	M10x25 LONG GALVANIZED BOLT C/W NUT & WASHER		FABRICATOR
11	50x200 C.G. FIR x 2000 LONG, PRESSURE TREATED AFTER CUTTING	3136-9	OTHER * W.S.C.

* WATER SURVEY OF CANADA EST. W.T. STEEL 142.3 kg
EST. W.T. WOOD 120.0 kg
TOTAL W.T. 267.3 kg

NOTES:

1. ALL PARTS TO BE HOT-DIPPED GALVANIZED C.S.A. G-164.
2. ALL BOLTS & NUTS TO BE M16 A325M TYPE 2, GALVANIZED UNLESS NOTED OTHERWISE.
3. ALL STEEL SHALL CONFORM TO C.S.A. G40.21M GR 350W.
4. DECKING AND KICK PLATES TO BE SUPPLIED BY W.S.C.

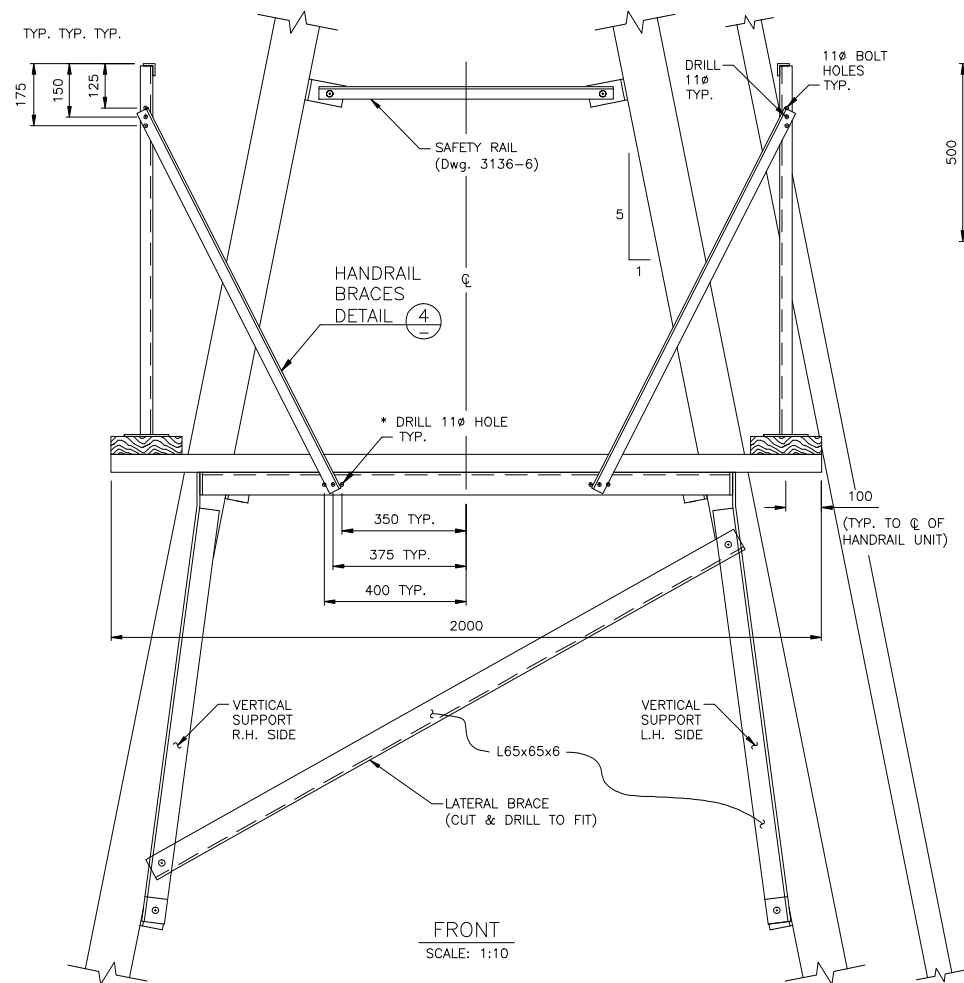

FRONT
SCALE: 1:10

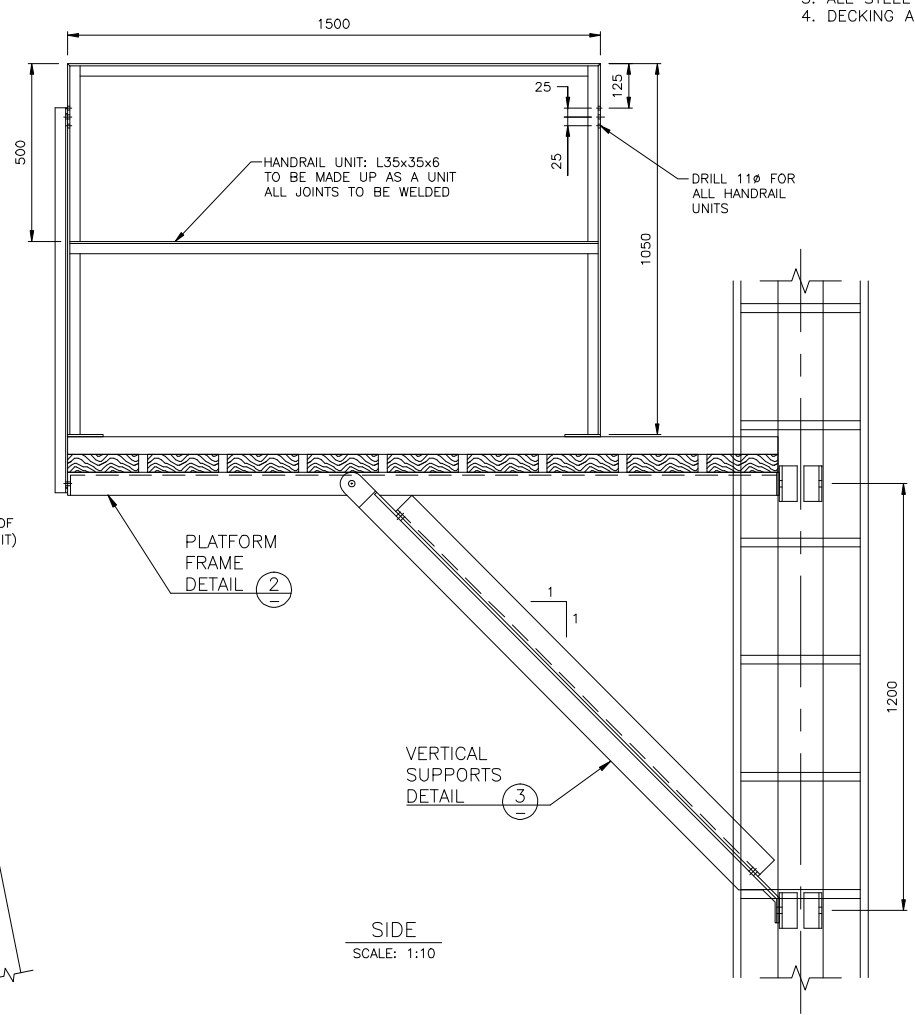

SIDE
SCALE: 1:10

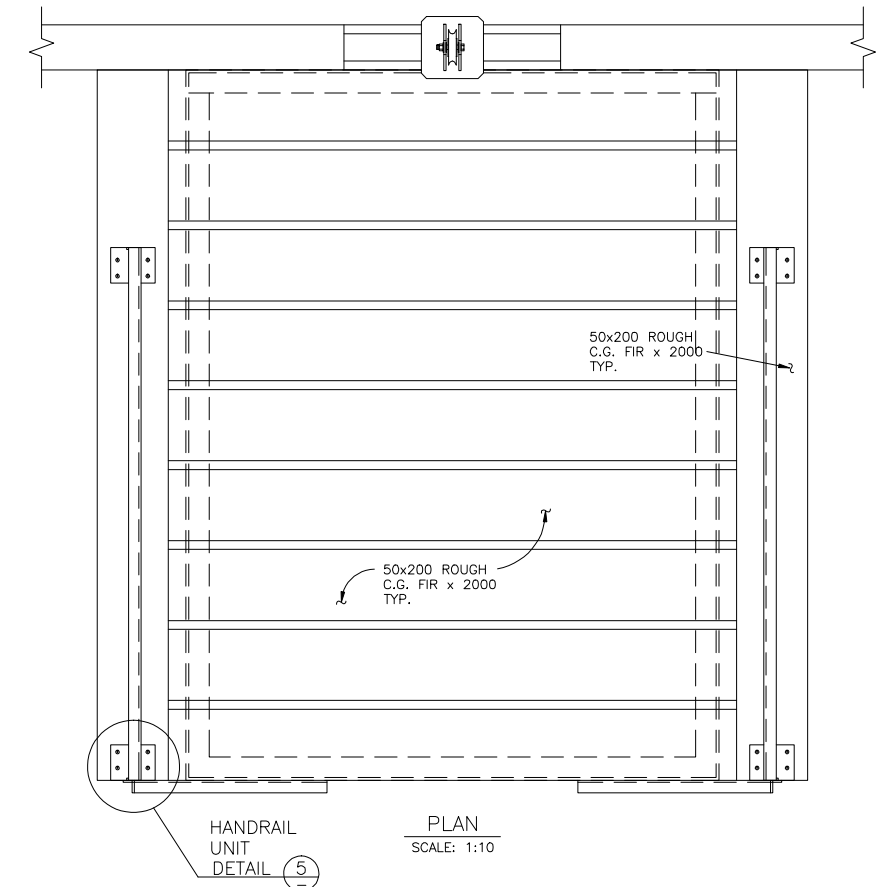

PLAN
SCALE: 1:10

ALL DIMENSIONS IN MILLIMETRES UNLESS OTHERWISE NOTED

No.	Date	Revision	Dr	Ch
1	JUNE/02	APPROVED AND REDRAWN BY MCSL	KDW	AAW

McElhanney
McElhanney Consulting Services Ltd.
13160-88 Ave., Surrey, B.C., Canada V3W 3K3 Telephone (604)596-0391
This drawing is the property of McElhanney Consulting Services Ltd. and cannot be used or reprinted without the written consent of said company.

DEPT. OF THE ENVIRONMENT
WATER SURVEY OF CANADA, VANCOUVER, B.C.
HEAVY DUTY A-FRAME
PLATFORM ASSEMBLY
VANCOUVER, B.C.

Designed D.O.E.	Job No. 2111-01745-1	Drawing No.
Drawn K.D.W.	Scale AS SHOWN	3136-9
Checked A.A.W.	Date APRIL 2002	
Approved	Revision 1	of 10

BILLS OF MATERIAL

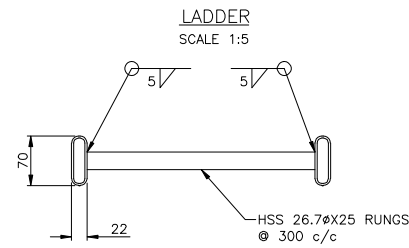
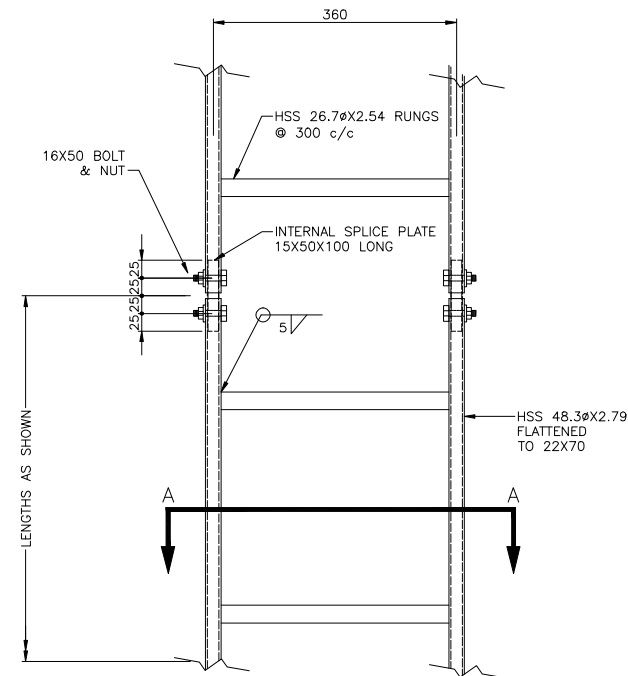

SECTION A
SCALE 1:5

A COMPLETE CAR HOOK ASSEMBLY CONSISTS OF THE FOLLOWING:			
QTY	DESCRIPTION	DWG No.	SUPPLIER
1	CAR HOOK C/W BRACKET	3136-10	FABRICATOR
2	BOLTS, M16x55 C/W NUT & WASHER		FABRICATOR

EST. W.T. 5.4 kg

NOTES:

1. ALL PARTS TO BE HOT-DIPPED GALVANIZED AS PER C.S.A. G-164.
2. ALL BOLTS & NUTS TO BE A325M TYPE 2 GALV., UNLESS NOTED OTHERWISE
3. ALL STEEL SHALL CONFORM TO C.S.A. G.40.21M GRADE 350W.

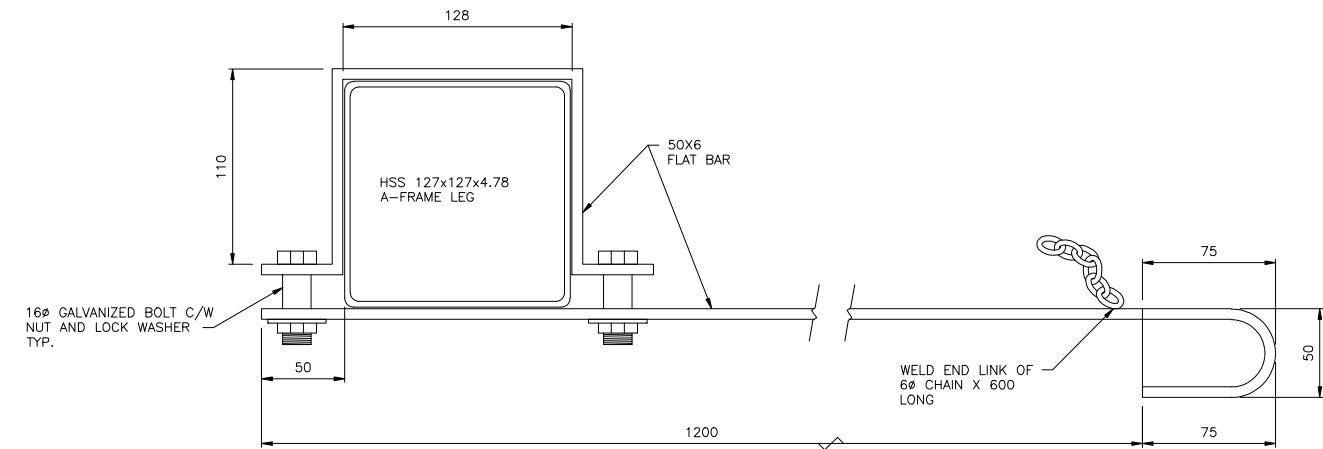

CAR HOOK ASSEMBLY LEG
SCALE 1:2

ALL DIMENSIONS IN MILLIMETRES
UNLESS OTHERWISE NOTED

No.	Date	Revision	Dr	Ch
1	JUNE/02	APPROVED AND REDRAWN BY MCSL	KDW	AAW



McElhanney
McElhanney Consulting Services Ltd.
13160-88 Ave., Surrey, B.C., Canada V3W 3K3 Telephone (604)596-0391
This drawing is the property of McElhanney Consulting Services Ltd. and cannot be used or reprinted without the written consent of said company.

DEPT. OF THE ENVIRONMENT
WATER SURVEY OF CANADA, VANCOUVER, B.C.
HEAVY DUTY A-FRAMES
LADDER BRACKET & CAR HOOK, VARIOUS DETAILS
ASSEMBLY LEG
VANCOUVER, B.C.

Designed	D.O.E.	Job No.	2111-01745-1	Drawing No.
Drawn	K.D.W.	Scale	AS NOTED	3136-10
Checked	A.A.W.	Date	APRIL 2002	
Approved		Revision	1	of 10

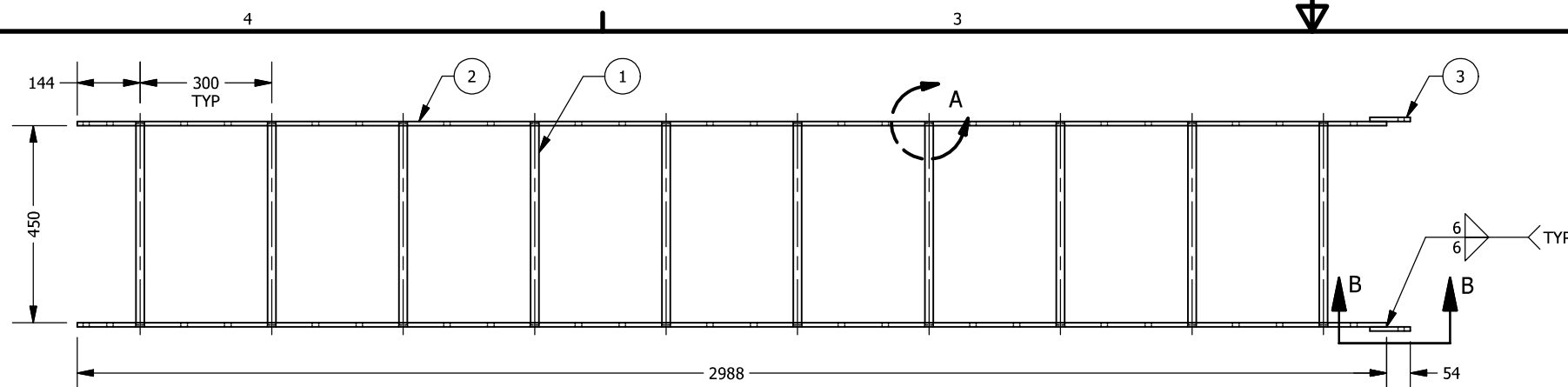

ITEM	QTY	DESCRIPTION	SIZE	LENGTH	MATERIAL	FINISH	DWG#
1	10	RUNG	ROUND BAR - Ø3/4"	460	CSA G40.21 350W	GALVANIZED	
2	2	SIDE RAIL	FLATBAR - 2 1/2" x 3/8"	2988	CSA G40.21 300W	GALVANIZED	
3	2	LADDER SPLICE PLATE	FLATBAR - 2 1/2" x 3/8"	92	CSA G40.21 300W	GALVANIZED	

EST. WT. 38.4 kg

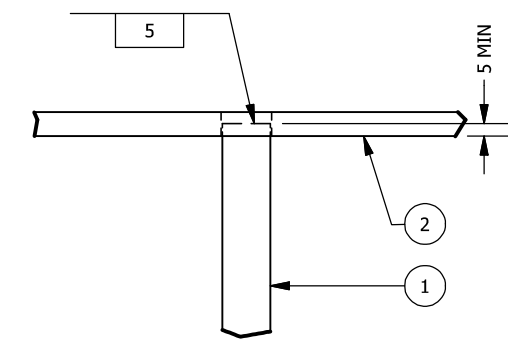

DETAIL A
TYPICAL RUNG DETAIL FOR ALL LADDERS

APEGA Permit# 06383

22 March 2019

22 March 2019

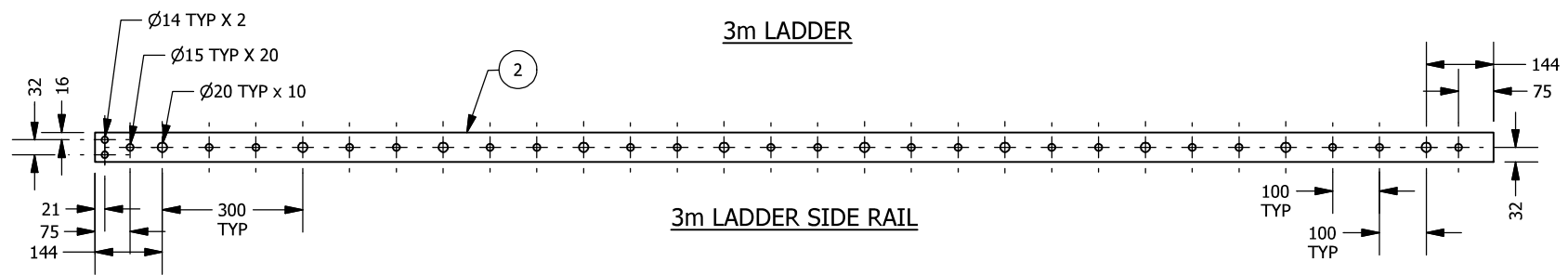

3m LADDER SIDE RAIL

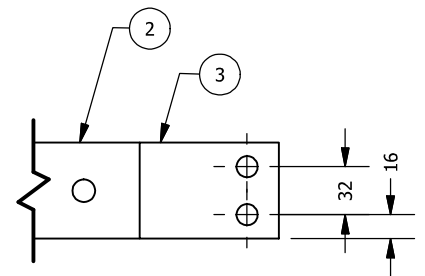

VIEW B-B
LADDER SPLICE PLATE DETAIL
ALL LADDERS

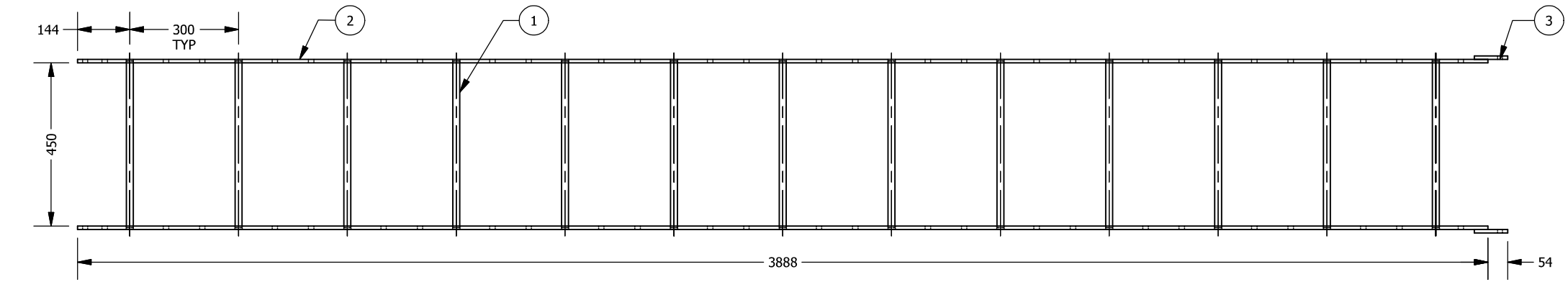

4m LADDER

ITEM	QTY	DESCRIPTION	SIZE	LENGTH	MATERIAL	FINISH	DWG#
1	13	RUNG	ROUND BAR - Ø3/4"	460	CSA G40.21 350W	GALVANIZED	
2	2	SIDE RAIL	FLATBAR - 2 1/2" x 3/8"	3888	CSA G40.21 300W	GALVANIZED	
3	2	LADDER SPLICE PLATE	FLATBAR - 2 1/2" x 3/8"	92	CSA G40.21 300W	GALVANIZED	

EST. W.T. 49.8 kg

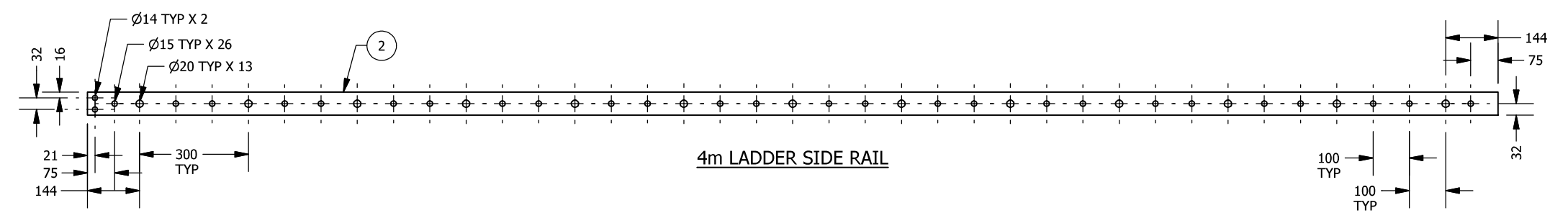

4m LADDER SIDE RAIL

- GENERAL NOTES**
- FABRICATE AND ERECT STRUCTURAL STEEL TO CAN/CSA S16 LIMIT STATES DESIGN OF STEEL STRUCTURES.
 - WELDING TO CONFORM TO CSA W-59 BY FABRICATORS CERTIFIED BY CANADIAN WELDING BUREAU (CWB) TO THE REQUIREMENTS OF CSA W47.1 DIVISION 1 OR 2.1. WELDS SHALL BE MADE WITH ELECTRODES AND FILLER MATERIAL RATED E480XX (E70XX) OR BETTER, UNLESS NOTED OTHERWISE.
 - ALL MATERIALS USED IN FABRICATION SHALL BE NEW, ACCOMPANIED BY MILL CERTIFICATES.
 - ALL EDGES SHOULD BE SMOOTH AND FREE FROM BURRS.
 - COMPLETE ASSEMBLIES SHALL BE HOT DIPPED GALVANIZED AS PER ASTM A123/A123M.

REV	DATE	DESCRIPTION
0	03/07/19	ISSUED FOR CONSTRUCTION

TOLERANCES & SURFACE FINISH - UNLESS OTHERWISE NOTED

FABRICATION	MACHINING	SURFACE FINISH
0 TO 600 ±1	X ±0.5	Ra = 3.2
>600 ±3	X,X ±0.1	
	X,XX ±0.01	

ALL DIMENSIONS IN mm UNLESS OTHERWISE NOTED.
DO NOT SCALE DRAWING

THIS DRAWING AND DESIGN IS THE PROPERTY OF McElhanney Consulting Services Ltd. (McElhanney) AND SHALL NOT BE USED, REUSED OR REPRODUCED WITHOUT THE CONSENT OF McElhanney.

McElhanney WILL NOT BE HELD RESPONSIBLE FOR THE IMPROPER OR UNAUTHORIZED USE OF THIS DRAWING AND DESIGN.

THIS DRAWING AND DESIGN HAS BEEN PREPARED FOR THE CLIENT IDENTIFIED, TO MEET THE STANDARDS AND REQUIREMENTS OF THE APPLICABLE PUBLIC AGENCIES AT THE TIME OF PREPARATION.

McElhanney, ITS EMPLOYEES, SUBCONSULTANTS AND AGENTS WILL NOT BE LIABLE FOR ANY LOSSES OR OTHER CONSEQUENCES RESULTING FROM THE USE OR RELIANCE UPON, OR ANY CHANGES MADE TO, THIS DRAWING, BY ANY THIRD PARTY, INCLUDING CONTRACTORS, SUPPLIERS, CONSULTANTS AND STAKEHOLDERS, OR THEIR EMPLOYEES OR AGENTS, WITHOUT McElhanney's PRIOR WRITTEN CONSENT.

McElhanney
McElhanney Consulting Services Ltd.

#203, 502 Bow Valley Trail
CANMORE AB, T1W 1N9
www.mcelhanney.com
PH (403) 609-3992

ENVIRONMENT CANADA
WATER SURVEY OF CANADA

3m & 4m LADDER ASSEMBLIES

DRAWING #

3136-11

PROJECT #
2531-36602

REV
0

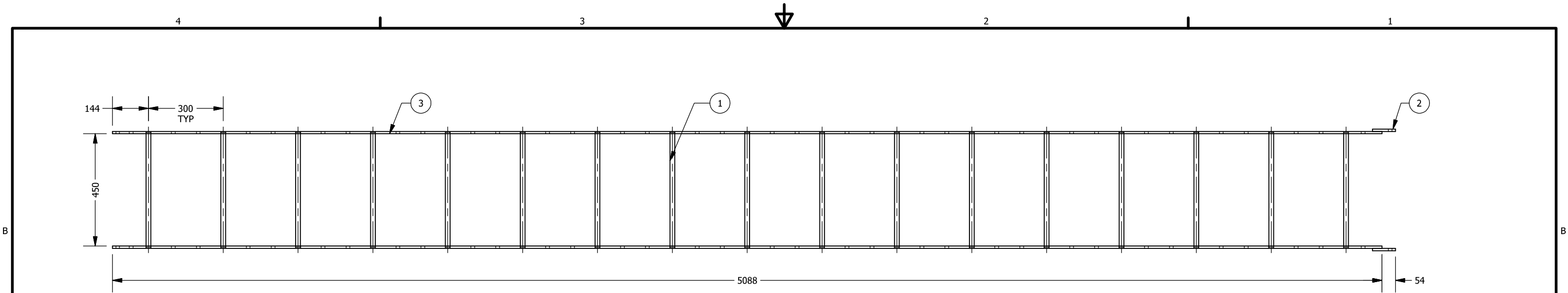

5m LADDER

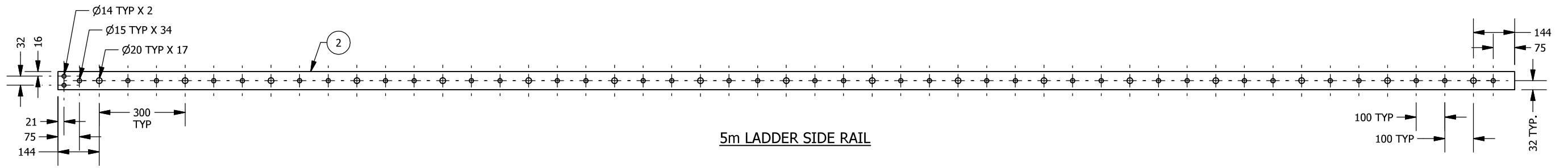

5m LADDER SIDE RAIL

5m LADDER BILL OF MATERIALS							
ITEM	QTY	DESCRIPTION	SIZE	LENGTH	MATERIAL	FINISH	DWG#
1	17	RUNG	ROUND BAR - Ø3/4"	460	CSA G40.21 350W	GALVANIZED	
2	2	LADDER SPLICE PLATE	FLATBAR - 2 1/2" x 3/8"	92	CSA G40.21 300W	GALVANIZED	
3	2	SIDE RAIL	FLATBAR - 2 1/2" x 3/8"	5088	CSA G40.21 300W	GALVANIZED	

EST. W.T. 64.9 kg

APEGA Permit# 06383



22 March 2019



22 March 2019

GENERAL NOTES

- FABRICATE AND ERECT STRUCTURAL STEEL TO CAN/CSA S16 LIMIT STATES DESIGN OF STEEL STRUCTURES.
- WELDING TO CONFORM TO CSA W-59 BY FABRICATORS CERTIFIED BY CANADIAN WELDING BUREAU (CWB) TO THE REQUIREMENTS OF CSA W47.1 DIVISION 1 OR 2.1. WELDS SHALL BE MADE WITH ELECTRODES AND FILLER MATERIAL RATED E480XX (E70XX) OR BETTER, UNLESS NOTED OTHERWISE.
- ALL MATERIALS USED IN FABRICATION SHALL BE NEW, ACCOMPANIED BY MILL CERTIFICATES.
- ALL EDGES SHOULD BE SMOOTH AND FREE FROM BURRS.
- COMPLETE ASSEMBLIES SHALL BE HOT DIPPED GALVANIZED AS PER ASTM A123/A123M.

REV	DATE	DESCRIPTION
0	03/07/19	ISSUED FOR CONSTRUCTION

TOLERANCES & SURFACE FINISH - UNLESS OTHERWISE NOTED

FABRICATION	MACHINING	SURFACE FINISH
0 TO 600 ±1	X ±0.5	Ra = 3.2
>600 ±3	X,X ±0.1	
	X,XX ±0.01	

ALL DIMENSIONS IN mm UNLESS OTHERWISE NOTED.
DO NOT SCALE DRAWING

THIS DRAWING AND DESIGN IS THE PROPERTY OF McELHANNEY CONSULTING SERVICES LTD. (McELHANNEY) AND SHALL NOT BE USED, REUSED OR REPRODUCED WITHOUT THE CONSENT OF McELHANNEY.

McELHANNEY WILL NOT BE HELD RESPONSIBLE FOR THE IMPROPER OR UNAUTHORIZED USE OF THIS DRAWING AND DESIGN.

THIS DRAWING AND DESIGN HAS BEEN PREPARED FOR THE CLIENT IDENTIFIED, TO MEET THE STANDARDS AND REQUIREMENTS OF THE APPLICABLE PUBLIC AGENCIES AT THE TIME OF PREPARATION.

McELHANNEY, ITS EMPLOYEES, SUBCONSULTANTS AND AGENTS WILL NOT BE LIABLE FOR ANY LOSSES OR OTHER CONSEQUENCES RESULTING FROM THE USE OR RELIANCE UPON, OR ANY CHANGES MADE TO, THIS DRAWING, BY ANY THIRD PARTY, INCLUDING CONTRACTORS, SUPPLIERS, CONSULTANTS AND STAKEHOLDERS, OR THEIR EMPLOYEES OR AGENTS, WITHOUT McELHANNEY'S PRIOR WRITTEN CONSENT.



#203, 502 Bow Valley Trail
CANMORE AB, T1W 1N9
www.mcelhanney.com
PH (403) 609-3992

ENVIRONMENT CANADA
WATER SURVEY OF CANADA

5m LADDER ASSEMBLY

DRAWING #	
3136-12	
PROJECT #	REV
2531-36602	0

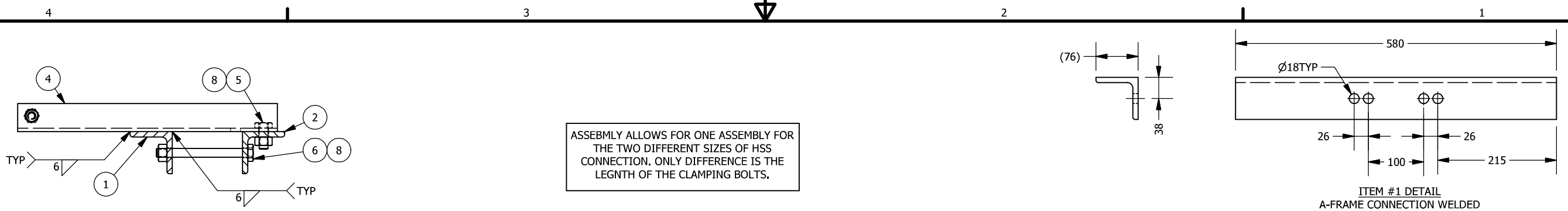

SECTION A-A
A-FRAME HSS OMITTED FOR CLARITY

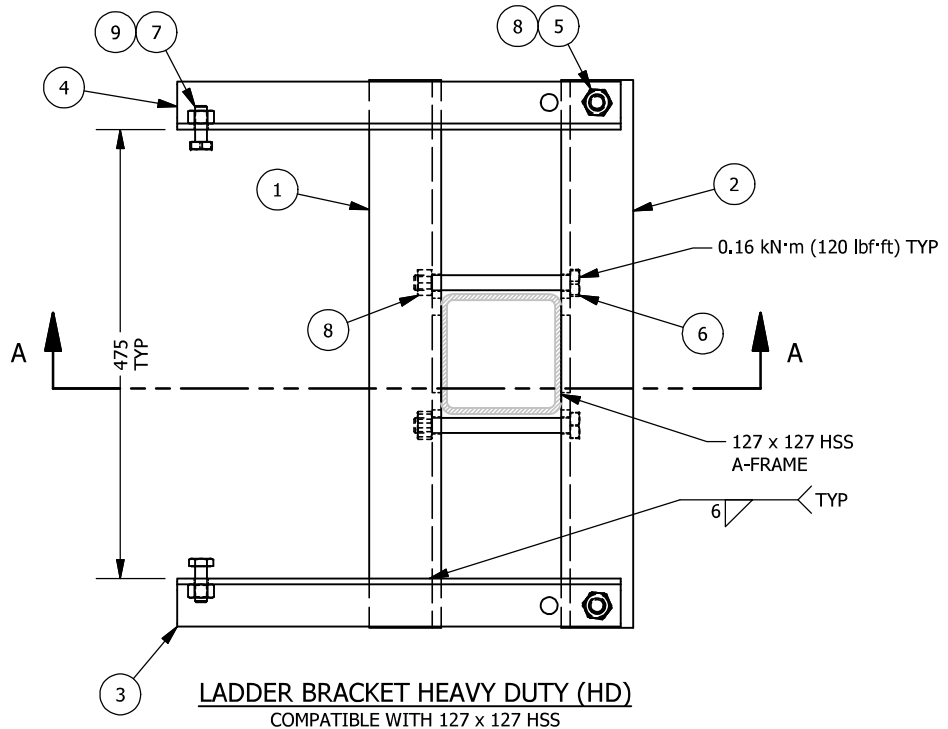

LADDER BRACKET HEAVY DUTY (HD)
COMPATIBLE WITH 127 x 127 HSS

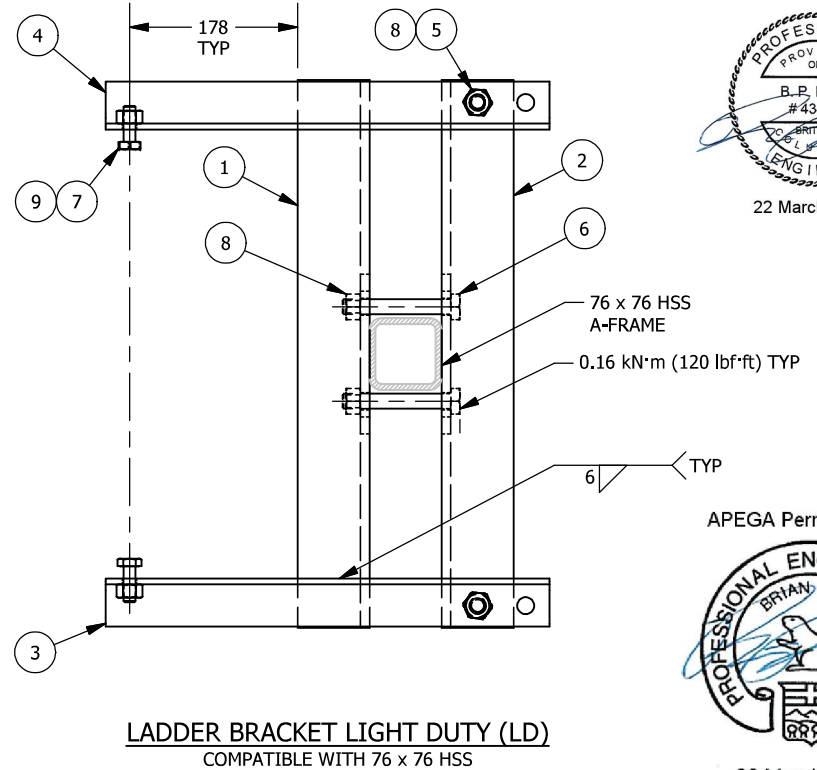

LADDER BRACKET LIGHT DUTY (LD)
COMPATIBLE WITH 76 x 76 HSS

ASSEMBLY ALLOWS FOR ONE ASSEMBLY FOR THE TWO DIFFERENT SIZES OF HSS CONNECTION. ONLY DIFFERENCE IS THE LENGTH OF THE CLAMPING BOLTS.

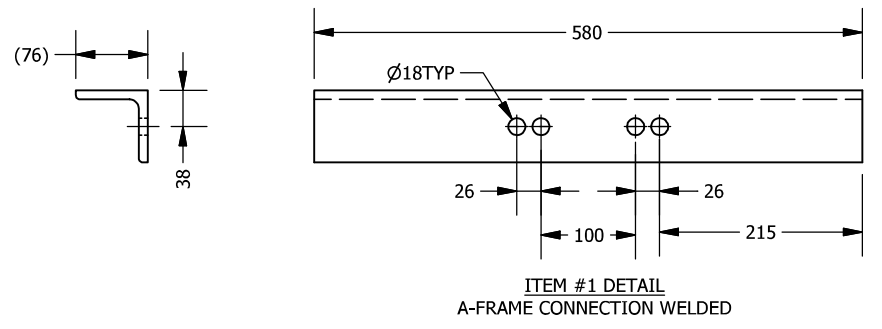
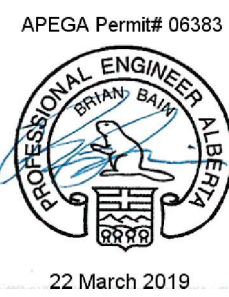

ITEM #1 DETAIL
A-FRAME CONNECTION WELDED

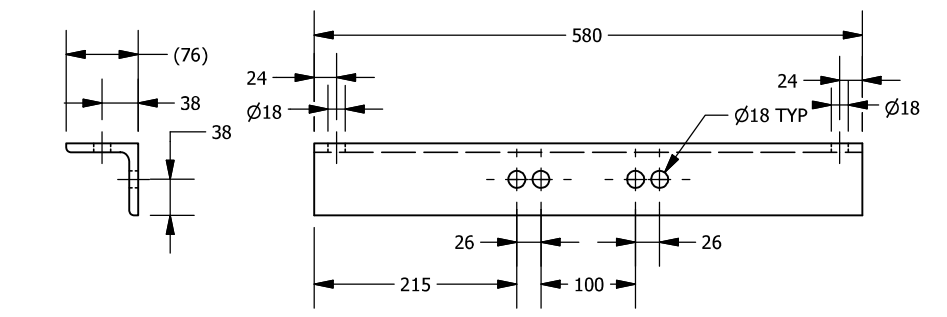

ITEM #2 DETAIL
A-FRAME CONNECTION BOLTED

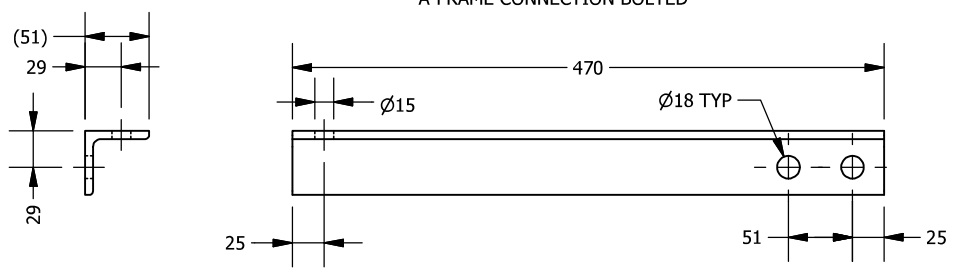

ITEM #3 DETAIL
LADDER CONNECTION ANGLE

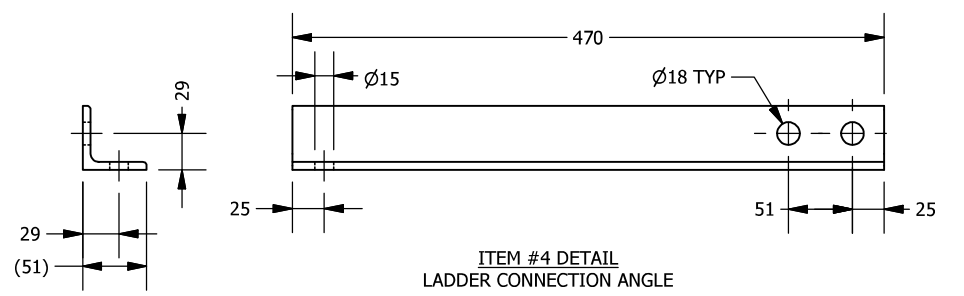

ITEM #4 DETAIL
LADDER CONNECTION ANGLE

HD LADDER BRACKET BILL OF MATERIALS							
ITEM	QTY	DESCRIPTION	SIZE	LENGTH	MATERIAL	FINISH	DWG#
1	1	A-FRAME WELDED	ANGLE - 3" x 3" x 3/8"	580	CSA G40.21 350W	GALVANIZED	
2	1	A-FRAME BOLTED	ANGLE - 3" x 3" x 3/8"	580	CSA G40.21 350W	GALVANIZED	
3	1	LADDER MOUNT ANGLE LEFT	ANGLE - 2" x 2" x 1/4"	470	CSA G40.21 350W	GALVANIZED	
4	1	LADDER MOUNT ANGLE RIGHT	ANGLE - 2" x 2" x 1/4"	470	CSA G40.21 350W	GALVANIZED	
5	2	HEX BOLT	5/8" - 11	1-1/2"	ASTM A325M	GALVANIZED	
6	2	HEX BOLT	5/8" - 11	6-1/2"	ASTM A325M	GALVANIZED	
7	2	HEX BOLT	1/2" - 13	1-1/2"	ASTM A325M	GALVANIZED	
8	4	HEX NUT	5/8" - 11		ASTM A325M	GALVANIZED	
9	2	HEX NUT	1/2" - 13		ASTM A325M	GALVANIZED	

EST. W.T. 18.0 kg

LD LADDER BRACKET BILL OF MATERIALS							
ITEM	QTY	DESCRIPTION	SIZE	LENGTH	MATERIAL	FINISH	DWG#
1	1	A-FRAME WELDED	ANGLE - 3" x 3" x 3/8"	580	CSA G40.21 350W	GALVANIZED	
2	1	A-FRAME BOLTED	ANGLE - 3" x 3" x 3/8"	580	CSA G40.21 350W	GALVANIZED	
3	1	LADDER MOUNT ANGLE LEFT	ANGLE - 2" x 2" x 1/4"	470	CSA G40.21 350W	GALVANIZED	
4	1	LADDER MOUNT ANGLE RIGHT	ANGLE - 2" x 2" x 1/4"	470	CSA G40.21 350W	GALVANIZED	
5	2	HEX BOLT	5/8" - 11	1-1/2"	ASTM A325M	GALVANIZED	
6	2	HEX BOLT	5/8" - 11	4-1/2"	ASTM A325M	GALVANIZED	
7	2	HEX BOLT	1/2" - 13	1-1/2"	ASTM A325M	GALVANIZED	
8	4	HEX NUT	5/8" - 11		ASTM A325M	GALVANIZED	
9	2	HEX NUT	1/2" - 13		ASTM A325M	GALVANIZED	

EST. W.T. 17.8 kg

GENERAL NOTES

- FABRICATE AND ERECT STRUCTURAL STEEL TO CAN/CSA S16 LIMIT STATES DESIGN OF STEEL STRUCTURES.
- WELDING TO CONFORM TO CSA W-59 BY FABRICATORS CERTIFIED BY CANADIAN WELDING BUREAU (CWB) TO THE REQUIREMENTS OF CSA W47.1 DIVISION 1 OR 2.1. WELDS SHALL BE MADE WITH ELECTRODES AND FILLER MATERIAL RATED E480XX (E70XX) OR BETTER, UNLESS NOTED OTHERWISE.
- ALL MATERIALS USED IN FABRICATION SHALL BE NEW, ACCOMPANIED BY MILL CERTIFICATES.
- ALL EDGES SHOULD BE SMOOTH AND FREE FROM BURRS.
- COMPLETE ASSEMBLIES SHALL BE HOT DIPPED GALVANIZED AS PER ASTM A123/A123M.

REV	DATE	DESCRIPTION
0	03/07/19	ISSUED FOR CONSTRUCTION

TOLERANCES & SURFACE FINISH - UNLESS OTHERWISE NOTED

FABRICATION	MACHINING	SURFACE FINISH
0 TO 600 ±1	X ±0.5	Ra = 3.2
>600 ±3	X,X ±0.1	
	X,XX ±0.01	

ALL DIMENSIONS IN mm UNLESS OTHERWISE NOTED.
DO NOT SCALE DRAWING

THIS DRAWING AND DESIGN IS THE PROPERTY OF McElhanney Consulting Services Ltd. (McElhanney) AND SHALL NOT BE USED, REUSED OR REPRODUCED WITHOUT THE CONSENT OF McElhanney.

McELHANNEY WILL NOT BE HELD RESPONSIBLE FOR THE IMPROPER OR UNAUTHORIZED USE OF THIS DRAWING AND DESIGN.

THIS DRAWING AND DESIGN HAS BEEN PREPARED FOR THE CLIENT IDENTIFIED, TO MEET THE STANDARDS AND REQUIREMENTS OF THE APPLICABLE PUBLIC AGENCIES AT THE TIME OF PREPARATION.

McELHANNEY, ITS EMPLOYEES, SUBCONSULTANTS AND AGENTS WILL NOT BE LIABLE FOR ANY LOSSES OR OTHER CONSEQUENCES RESULTING FROM THE USE OR RELIANCE UPON, OR ANY CHANGES MADE TO, THIS DRAWING, BY ANY THIRD PARTY, INCLUDING CONTRACTORS, SUPPLIERS, CONSULTANTS AND STAKEHOLDERS, OR THEIR EMPLOYEES OR AGENTS, WITHOUT McELHANNEY'S PRIOR WRITTEN CONSENT.



#203, 502 Bow Valley Trail
CANMORE AB, T1W 1N9
www.mcelhanney.com
PH (403) 609-3992

ENVIRONMENT CANADA
WATER SURVEY OF CANADA

LADDER BRACKETS

DRAWING #

3136-13

PROJECT #
2531-36602

REV
0

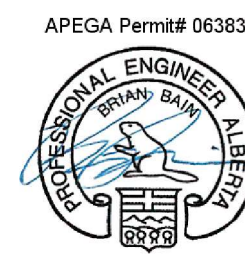
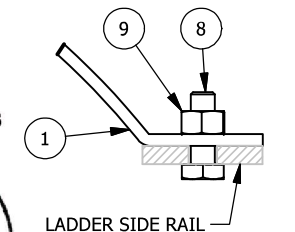
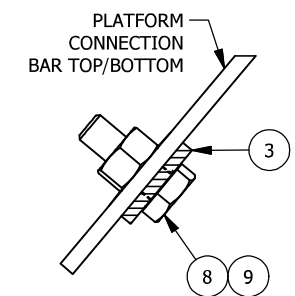
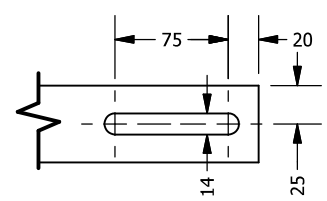
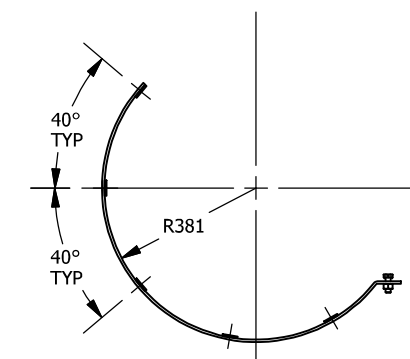
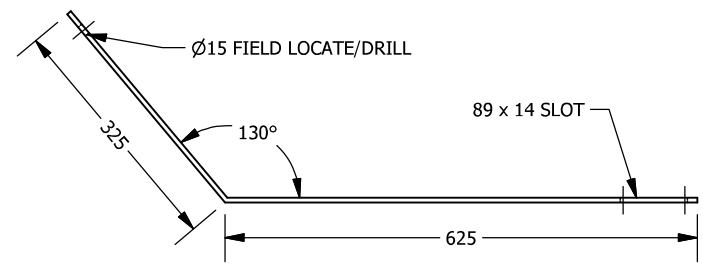
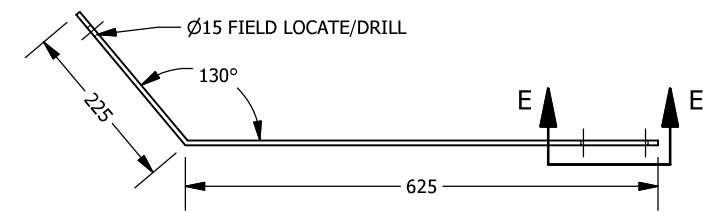
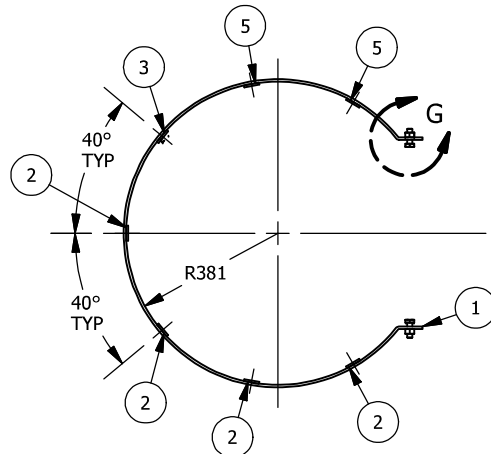
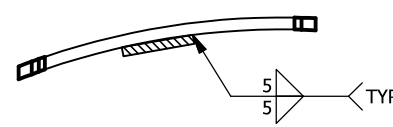
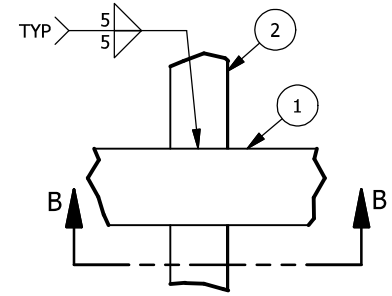
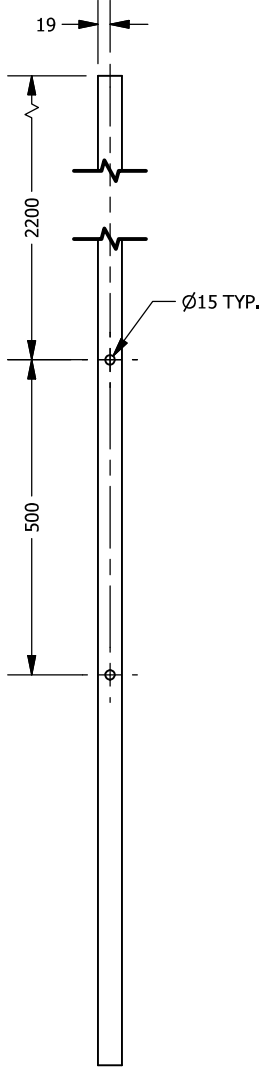
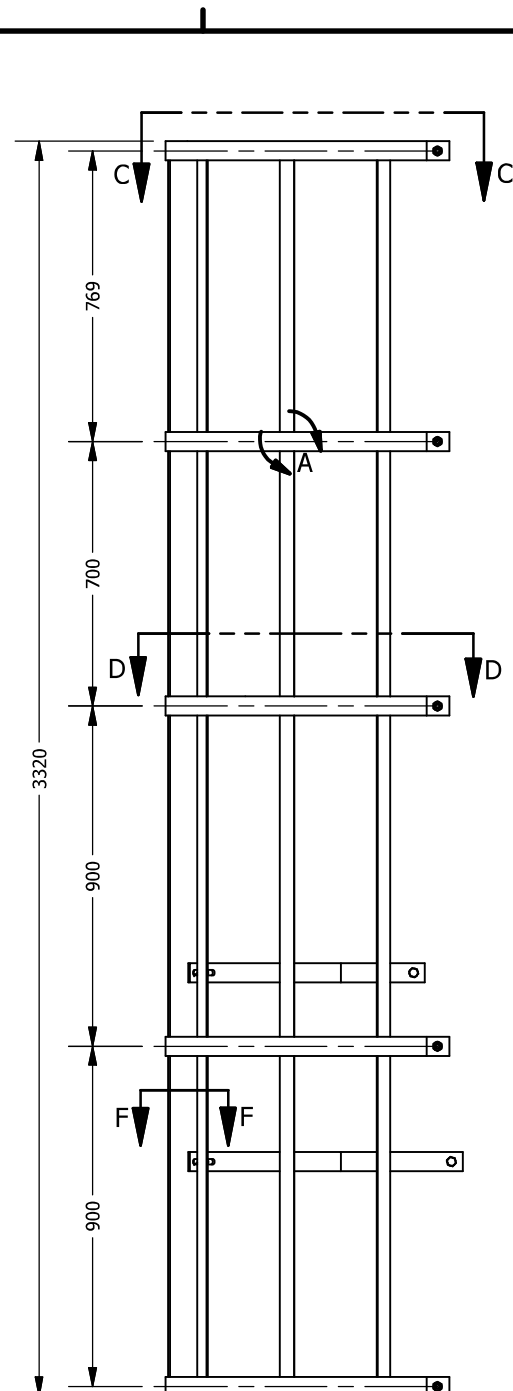
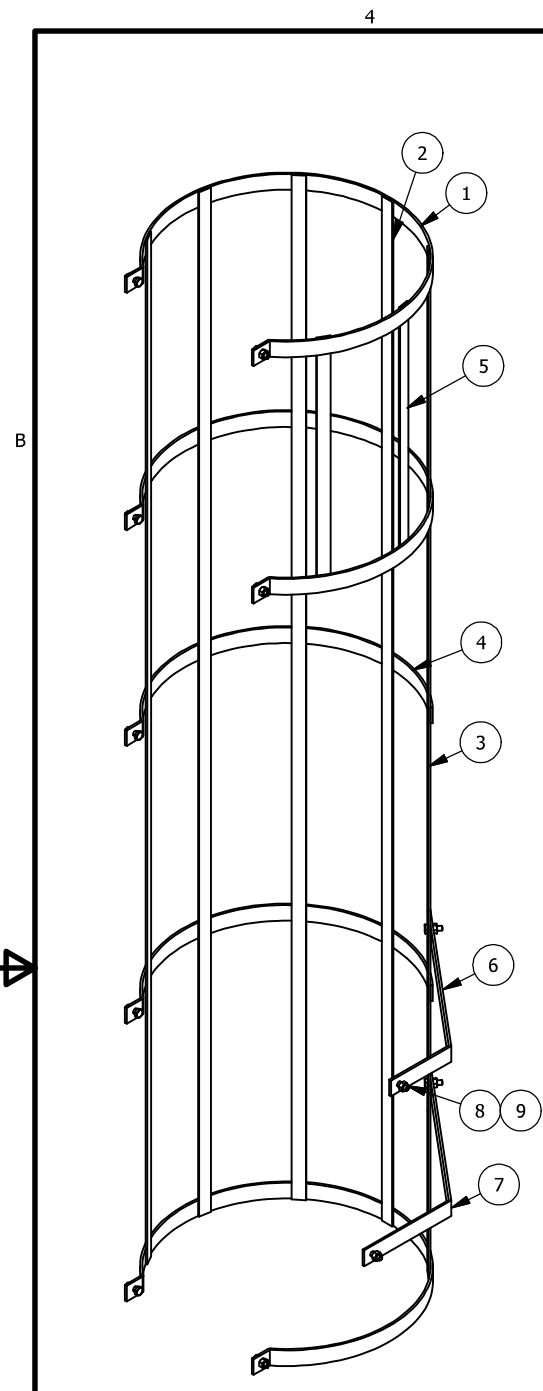

- GENERAL NOTES**
- FABRICATE AND ERECT STRUCTURAL STEEL TO CAN/CSA S16 LIMIT STATES DESIGN OF STEEL STRUCTURES.
 - WELDING TO CONFORM TO CSA W-59 BY FABRICATORS CERTIFIED BY CANADIAN WELDING BUREAU (CWB) TO THE REQUIREMENTS OF CSA W47.1 DIVISION 1 OR 2.1. WELDS SHALL BE MADE WITH ELECTRODES AND FILLER MATERIAL RATED E480XX (E70XX) OR BETTER, UNLESS NOTED OTHERWISE.
 - ALL MATERIALS USED IN FABRICATION SHALL BE NEW, ACCOMPANIED BY MILL CERTIFICATES.
 - ALL EDGES SHOULD BE SMOOTH AND FREE FROM BURRS.
 - COMPLETE ASSEMBLIES SHALL BE HOT DIPPED GALVANIZED AS PER ASTM A123/A123M.
 - PLATFORM CONNECTION BAR TOP/BOTTOM ITEMS FIELD INSTALLED BASED ON MODIFIED PLATFORM RAILING LOCATION.

BILL OF MATERIALS						
ITEM	QTY	DESCRIPTION	SIZE	LENGTH	MATERIAL	FINISH
1	3	HORIZ. BAND REGULAR	FLATBAR - 2" x 1/4"	2041	CSA G40.21 300W	GALVANIZED
2	4	VERT. BAND STRAIGHT TOP	FLATBAR - 1 1/2" x 3/16"	3320	CSA G40.21 300W	GALVANIZED
3	1	VERT. BAND STRAIGHT TOP - PLATFORM CONN.	FLATBAR - 1 1/2" x 3/16"	3320	CSA G40.21 300W	GALVANIZED
4	2	HORIZ. BAND OPENING	FLATBAR - 2" x 1/4"	1311	CSA G40.21 300W	GALVANIZED
5	2	VERT. BAND OPENING	FLATBAR - 1 1/2" x 3/16"	820	CSA G40.21 300W	GALVANIZED
6	1	PLATFORM CONNECTION BAR TOP	FLATBAR - 2" x 1/4"	850	CSA G40.21 300W	GALVANIZED
7	1	PLATFORM CONNECTION BAR BOTTOM	FLATBAR - 2" x 1/4"	950	CSA G40.21 300W	GALVANIZED
8	12	HEX BOLT	1/2" - 13	1 1/2"	ASTM A325	GALVANIZED
9	12	HEX NUT	1/2" - 13		ASTM A325	GALVANIZED

REV	DATE	DESCRIPTION
0	03/07/19	ISSUED FOR CONSTRUCTION

TOLERANCES & SURFACE FINISH - UNLESS OTHERWISE NOTED

FABRICATION	MACHINING	SURFACE FINISH
0 TO 600 ±1	X ±0.5	Ra = 3.2
>600 ±3	X,X ±0.1	
	X,XX ±0.01	

ALL DIMENSIONS IN mm UNLESS OTHERWISE NOTED.
DO NOT SCALE DRAWING

THIS DRAWING AND DESIGN IS THE PROPERTY OF McElhanney Consulting Services Ltd. (McElhanney) AND SHALL NOT BE USED, REUSED OR REPRODUCED WITHOUT THE CONSENT OF McElhanney.

McElhanney WILL NOT BE HELD RESPONSIBLE FOR THE IMPROPER OR UNAUTHORIZED USE OF THIS DRAWING AND DESIGN.

THIS DRAWING AND DESIGN HAS BEEN PREPARED FOR THE CLIENT IDENTIFIED, TO MEET THE STANDARDS AND REQUIREMENTS OF THE APPLICABLE PUBLIC AGENCIES AT THE TIME OF PREPARATION.

McElhanney, ITS EMPLOYEES, SUBCONSULTANTS AND AGENTS WILL NOT BE LIABLE FOR ANY LOSSES OR OTHER CONSEQUENCES RESULTING FROM THE USE OR RELIANCE UPON, OR ANY CHANGES MADE TO, THIS DRAWING, BY ANY THIRD PARTY, INCLUDING CONTRACTORS, SUPPLIERS, CONSULTANTS AND STAKEHOLDERS, OR THEIR EMPLOYEES OR AGENTS, WITHOUT McElhanney's PRIOR WRITTEN CONSENT.



#203, 502 Bow Valley Trail
CANMORE AB, T1W 1N9
www.mcelhanney.com
PH (403) 609-3992

ENVIRONMENT CANADA
WATER SURVEY OF CANADA

TOP LADDER CAGE

DRAWING #
3136-14

PROJECT #
2531-36602

REV
0

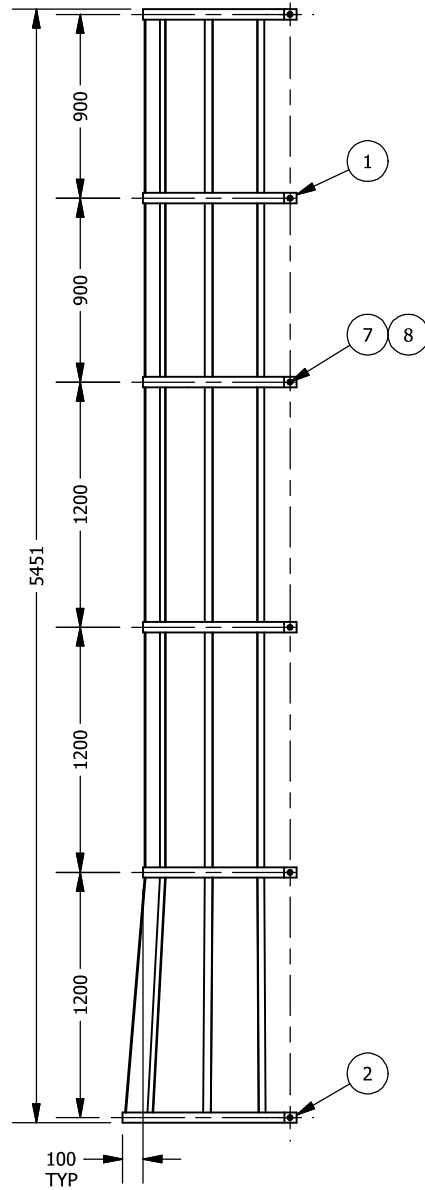

LONG FLARE LADDER CAGE

EST. W.T. 86.9 kg

ITEM	QTY	DESCRIPTION	SIZE	LENGTH	MATERIAL	FINISH	DWG#
1	5	HORIZ. BAND REGULAR	FLATBAR - 2" x 1/4"	2041	CSA G40.21 300W	GALVANIZED	3136-16
2	1	HORIZ. BAND BOTTOM	FLATBAR - 2" x 1/4"	2332	CSA G40.21 300W	GALVANIZED	3136-16
3	1	VERT. BAND CENTER	FLATBAR - 1 1/2" x 3/16"	5455	CSA G40.21 300W	GALVANIZED	
4	2	VERT. BAND A	FLATBAR - 1 1/2" x 3/16"	5454	CSA G40.21 300W	GALVANIZED	
5	2	VERT. BAND B	FLATBAR - 1 1/2" x 3/16"	5452	CSA G40.21 300W	GALVANIZED	
6	2	VERT. BAND C	FLATBAR - 1 1/2" x 3/16"	5451	CSA G40.21 300W	GALVANIZED	
7	12	HEX BOLT	1/2" - 13	1 1/2"	ASTM A325	GALVANIZED	
8	12	HEX NUT	1/2" - 13		ASTM A325	GALVANIZED	

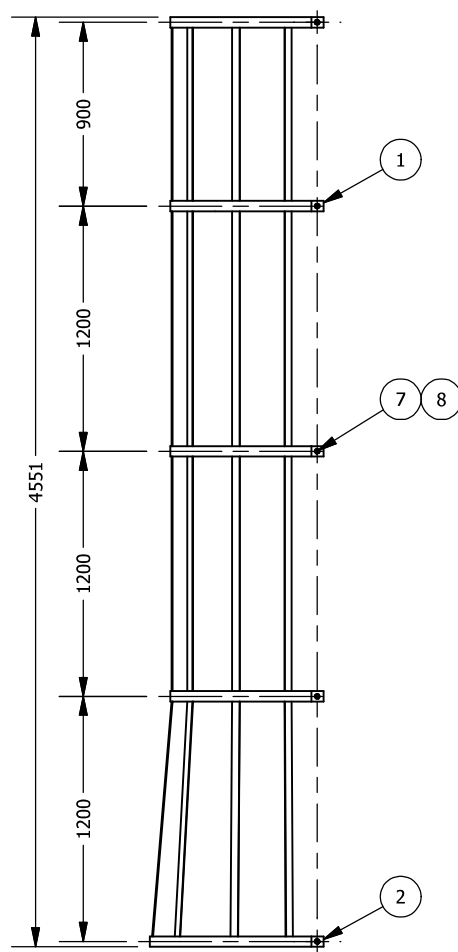

MEDIUM FLARE LADDER CAGE

EST. W.T. 72.6 kg

ITEM	QTY	DESCRIPTION	SIZE	LENGTH	MATERIAL	FINISH	DWG#
1	4	HORIZ. BAND REGULAR	FLATBAR - 2" x 1/4"	2041	CSA G40.21 300W	GALVANIZED	3136-16
2	1	HORIZ. BAND BOTTOM	FLATBAR - 2" x 1/4"	2332	CSA G40.21 300W	GALVANIZED	3136-16
3	1	VERT. BAND CENTER	FLATBAR - 1 1/2" x 3/16"	4555	CSA G40.21 300W	GALVANIZED	
4	2	VERT. BAND A	FLATBAR - 1 1/2" x 3/16"	4554	CSA G40.21 300W	GALVANIZED	
5	2	VERT. BAND B	FLATBAR - 1 1/2" x 3/16"	4552	CSA G40.21 300W	GALVANIZED	
6	2	VERT. BAND C	FLATBAR - 1 1/2" x 3/16"	4551	CSA G40.21 300W	GALVANIZED	
7	10	HEX BOLT	1/2" - 13	1 1/2"	ASTM A325	GALVANIZED	
8	10	HEX NUT	1/2" - 13		ASTM A325	GALVANIZED	

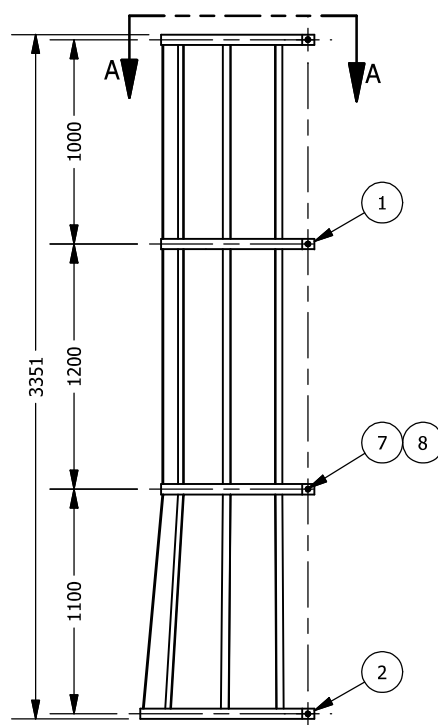

SHORT FLARE LADDER CAGE

EST. W.T. 55.4 kg

ITEM	QTY	DESCRIPTION	SIZE	LENGTH	MATERIAL	FINISH	DWG#
1	3	HORIZ. BAND REGULAR	FLATBAR - 2" x 1/4"	2041	CSA G40.21 300W	GALVANIZED	3136-16
2	1	HORIZ. BAND BOTTOM	FLATBAR - 2" x 1/4"	2332	CSA G40.21 300W	GALVANIZED	3136-16
3	1	VERT. BAND CENTER	FLATBAR - 1 1/2" x 3/16"	3355	CSA G40.21 300W	GALVANIZED	
4	2	VERT. BAND A	FLATBAR - 1 1/2" x 3/16"	3354	CSA G40.21 300W	GALVANIZED	
5	2	VERT. BAND B	FLATBAR - 1 1/2" x 3/16"	3352	CSA G40.21 300W	GALVANIZED	
6	2	VERT. BAND C	FLATBAR - 1 1/2" x 3/16"	3351	CSA G40.21 300W	GALVANIZED	
7	8	HEX BOLT	1/2" - 13	1 1/2"	ASTM A325	GALVANIZED	
8	8	HEX NUT	1/2" - 13		ASTM A325	GALVANIZED	

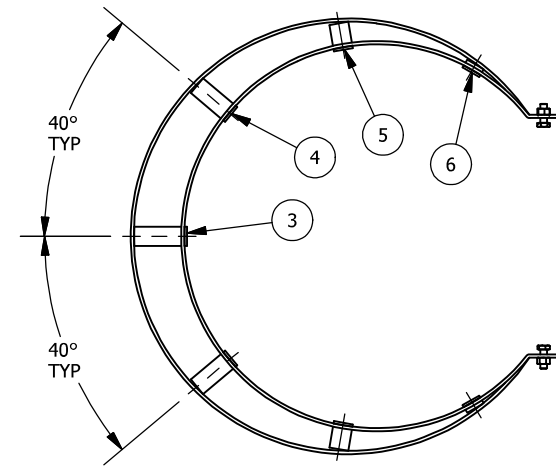

VIEW A-A
TYPICAL VERTICAL BAND LAYOUT FOR ALL LENGTHS

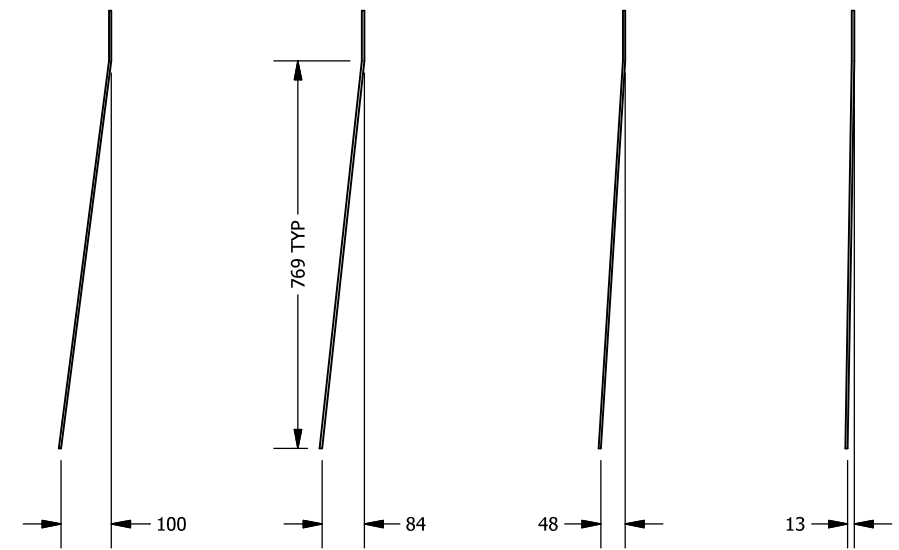

ITEM #3 DETAIL VERT. BAND CENTER
ITEM #4 DETAIL VERT. BAND A
ITEM #5 DETAIL VERT. BAND B
ITEM #6 DETAIL VERT. BAND C



APEGA Permit# 06383

22 March 2019

22 March 2019

TYPICAL CONNECTION AND WELD DETAILS ON 3136-14

GENERAL NOTES

- FABRICATE AND ERECT STRUCTURAL STEEL TO CAN/CSA S16 LIMIT STATES DESIGN OF STEEL STRUCTURES.
- WELDING TO CONFORM TO CSA W-59 BY FABRICATORS CERTIFIED BY CANADIAN WELDING BUREAU (CWB) TO THE REQUIREMENTS OF CSA W47.1 DIVISION 1 OR 2.1. WELDS SHALL BE MADE WITH ELECTRODES AND FILLER MATERIAL RATED E480XX (E70XX) OR BETTER, UNLESS NOTED OTHERWISE.
- ALL MATERIALS USED IN FABRICATION SHALL BE NEW, ACCOMPANIED BY MILL CERTIFICATES.
- ALL EDGES SHOULD BE SMOOTH AND FREE FROM BURRS.
- COMPLETE ASSEMBLIES SHALL BE HOT DIPPED GALVANIZED AS PER ASTM A123/A123M.

TOLERANCES & SURFACE FINISH - UNLESS OTHERWISE NOTED

FABRICATION	MACHINING	SURFACE FINISH
0 TO 600 ±1	X ±0.5	Ra = 3.2
>600 ±3	X,X ±0.1	
	X,XX ±0.01	

ALL DIMENSIONS IN mm UNLESS OTHERWISE NOTED.
DO NOT SCALE DRAWING

THIS DRAWING AND DESIGN IS THE PROPERTY OF McElhanney Consulting Services Ltd. (McElhanney) AND SHALL NOT BE USED, REUSED OR REPRODUCED WITHOUT THE CONSENT OF McElhanney.

McELHANNEY WILL NOT BE HELD RESPONSIBLE FOR THE IMPROPER OR UNAUTHORIZED USE OF THIS DRAWING AND DESIGN.

THIS DRAWING AND DESIGN HAS BEEN PREPARED FOR THE CLIENT IDENTIFIED, TO MEET THE STANDARDS AND REQUIREMENTS OF THE APPLICABLE PUBLIC AGENCIES AT THE TIME OF PREPARATION.

McELHANNEY, ITS EMPLOYEES, SUBCONSULTANTS AND AGENTS WILL NOT BE LIABLE FOR ANY LOSSES OR OTHER CONSEQUENCES RESULTING FROM THE USE OR RELIANCE UPON, OR ANY CHANGES MADE TO, THIS DRAWING, BY ANY THIRD PARTY, INCLUDING CONTRACTORS, SUPPLIERS, CONSULTANTS AND STAKEHOLDERS, OR THEIR EMPLOYEES OR AGENTS, WITHOUT McELHANNEY'S PRIOR WRITTEN CONSENT.



McElhanney

McElhanney Consulting Services Ltd.

#203, 502 Bow Valley Trail
CANMORE AB, T1W 1N9
www.mcelhanney.com
PH (403) 609-3992

ENVIRONMENT CANADA
WATER SURVEY OF CANADA

FLARED LADDER CAGE

DRAWING #

3136-15

PROJECT #
2531-36602

REV
0

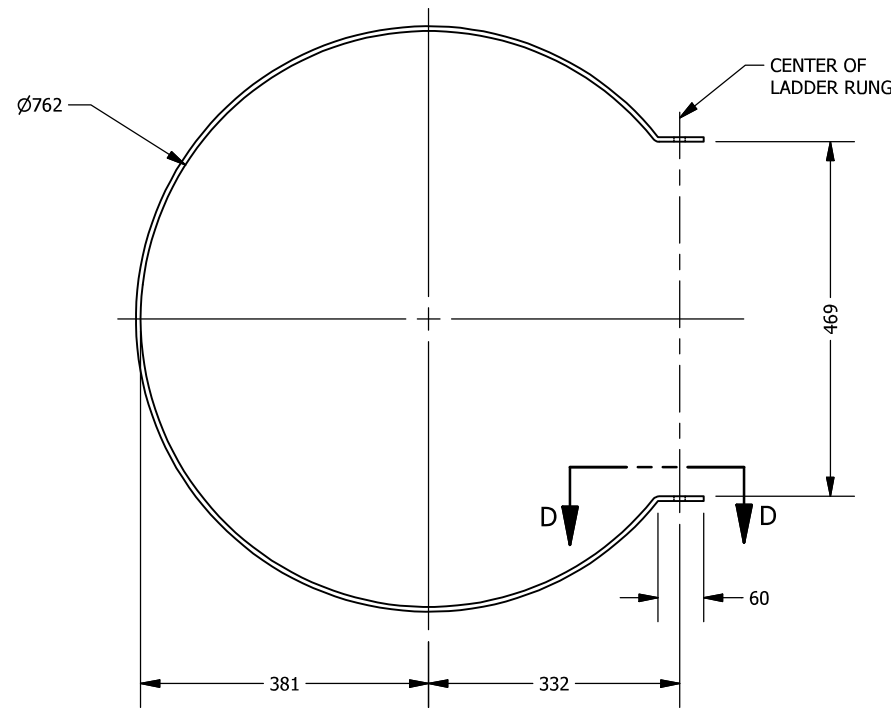

HORIZONTAL BAND REGULAR

SIZE	LENGTH	MATERIAL	FINISH
FLATBAR - 2" x 1/4"	2041	CSA G40.21 300W	GALVANIZED

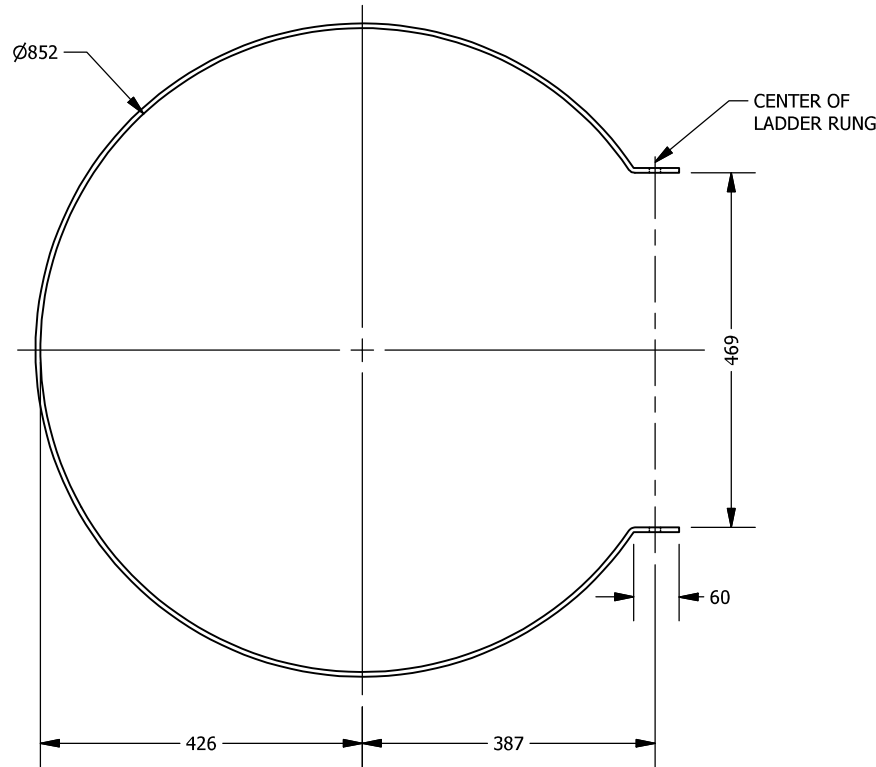

HORIZONTAL BAND BOTTOM

SIZE	LENGTH	MATERIAL	FINISH
FLATBAR - 2" x 1/4"	2332	CSA G40.21 300W	GALVANIZED

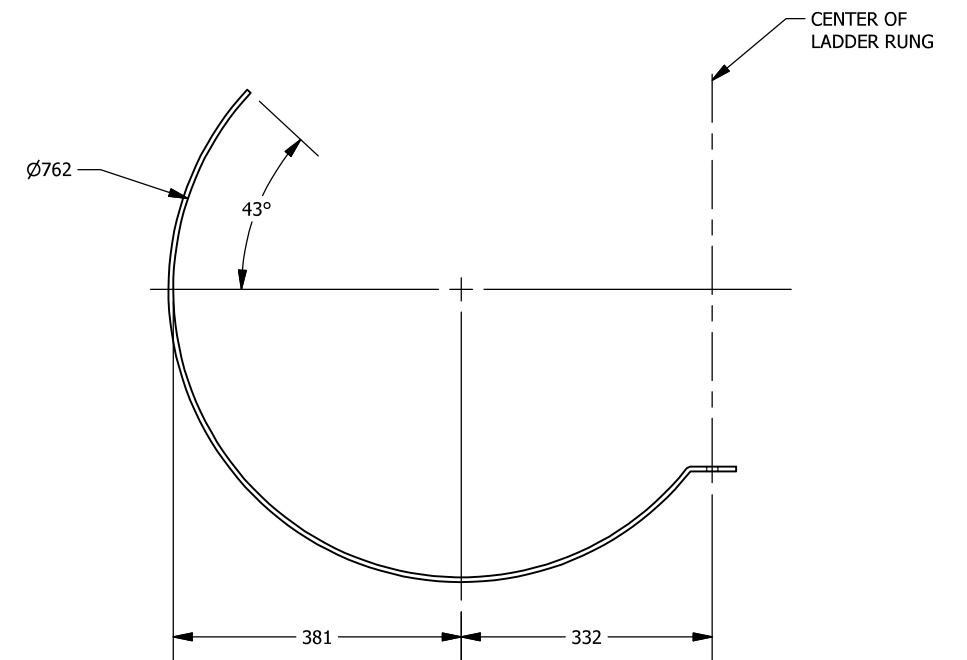

HORIZONTAL BAND OPENING

SIZE	LENGTH	MATERIAL	FINISH
FLATBAR - 2" x 1/4"	1311	CSA G40.21 300W	GALVANIZED

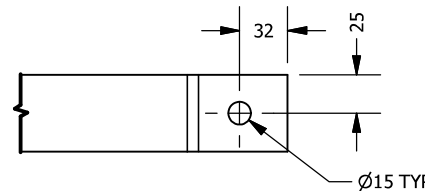

SECTION D-D
TYPICAL HOLE PATTERN FOR ALL HORIZONTAL BANDS

APEGA Permit# 06383



22 March 2019

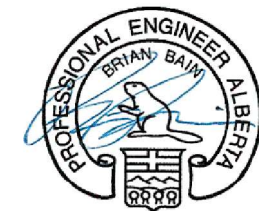

22 March 2019

GENERAL NOTES

- FABRICATE AND ERECT STRUCTURAL STEEL TO CAN/CSA S16 LIMIT STATES DESIGN OF STEEL STRUCTURES.
- ALL MATERIALS USED IN FABRICATION SHALL BE NEW, ACCOMPANIED BY MILL CERTIFICATES.
- ALL EDGES SHOULD BE SMOOTH AND FREE FROM BURRS.
- COMPLETE ASSEMBLIES SHALL BE HOT DIPPED GALVANIZED AS PER ASTM A123/A123M.

REV	DATE	DESCRIPTION
0	03/07/19	ISSUED FOR CONSTRUCTION

TOLERANCES & SURFACE FINISH - UNLESS OTHERWISE NOTED

FABRICATION	MACHINING	SURFACE FINISH
0 TO 600 ±1	X ±0.5	Ra = 3.2
>600 ±3	X,X ±0.1	
	X,XX ±0.01	

ALL DIMENSIONS IN mm UNLESS OTHERWISE NOTED.
DO NOT SCALE DRAWING

THIS DRAWING AND DESIGN IS THE PROPERTY OF McELHANNEY CONSULTING SERVICES LTD. (McELHANNEY) AND SHALL NOT BE USED, REUSED OR REPRODUCED WITHOUT THE CONSENT OF McELHANNEY.

McELHANNEY WILL NOT BE HELD RESPONSIBLE FOR THE IMPROPER OR UNAUTHORIZED USE OF THIS DRAWING AND DESIGN.

THIS DRAWING AND DESIGN HAS BEEN PREPARED FOR THE CLIENT IDENTIFIED, TO MEET THE STANDARDS AND REQUIREMENTS OF THE APPLICABLE PUBLIC AGENCIES AT THE TIME OF PREPARATION.

McELHANNEY, ITS EMPLOYEES, SUBCONSULTANTS AND AGENTS WILL NOT BE LIABLE FOR ANY LOSSES OR OTHER CONSEQUENCES RESULTING FROM THE USE OR RELIANCE UPON, OR ANY CHANGES MADE TO, THIS DRAWING, BY ANY THIRD PARTY, INCLUDING CONTRACTORS, SUPPLIERS, CONSULTANTS AND STAKEHOLDERS, OR THEIR EMPLOYEES OR AGENTS, WITHOUT McELHANNEY'S PRIOR WRITTEN CONSENT.



McElhanney

McElhanney Consulting Services Ltd.

#203, 502 Bow Valley Trail
CANMORE AB, T1W 1N9
www.mcelhanney.com
PH (403) 609-3992

ENVIRONMENT CANADA
WATER SURVEY OF CANADA

LADDER CAGE HORIZONTAL BAND DETAILS

DRAWING #

3136-16

PROJECT #
2531-36602

REV
0

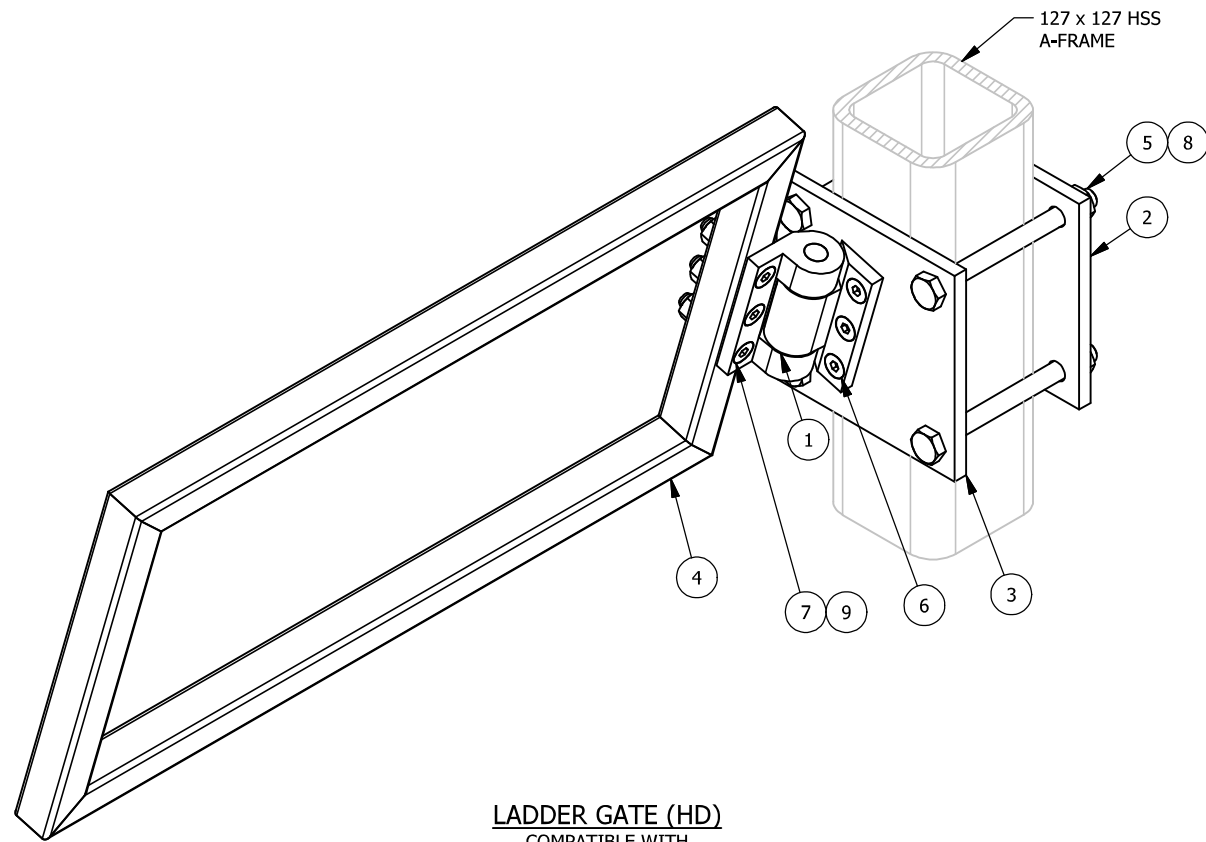

LADDER GATE (HD)
COMPATIBLE WITH
127 x 127 HSS

EST. W.T. 11.3kg

LADDER GATE (HD) BILL OF MATERIALS						
ITEM	QTY	DESCRIPTION	SIZE	LENGTH	MATERIAL	FINISH
1	1	HINGE - MCMMASTER-CARR 1484A31			STEEL	
2	1	HD BACKING PLATE	PLATE - 1/2"	200 x 200	CSA G40.21 300W	GALVANIZED
3	1	HINGE MOUNT HD	PLATE - 1/2"	200 x 200	CSA G40.21 300W	GALVANIZED
4	1	GATE				GALVANIZED
6	3	HEX SOCKET COUNTERSUNK BOLT	1/2" - 13	1"	ASTM F835	BLACK OXIDE
7	3	HEX SOCKET COUNTERSUNK BOLT	1/2" - 13	2-3/4"	ASTM F835	BLACK OXIDE
5	4	HEX BOLT	5/8" - 11	7"	ASTM A325M	GALVANIZED
8	4	HEX NUT	5/8" - 11		ASTM A325M	GALVANIZED
9	3	HEX NUT	1/2" - 13		ASTM A325M	GALVANIZED

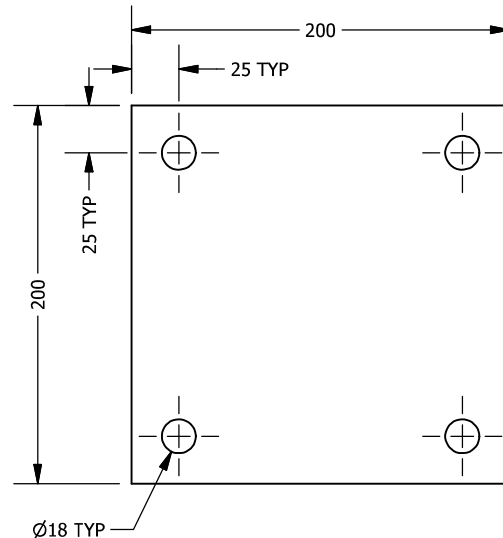

ITEM #2 DETAIL
HD BACKING PLATE

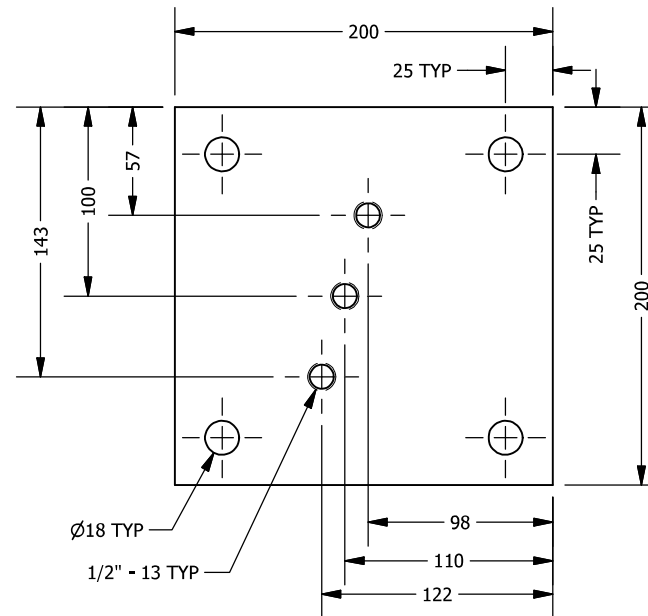

ITEM #3 DETAIL
HINGE MOUNT HD

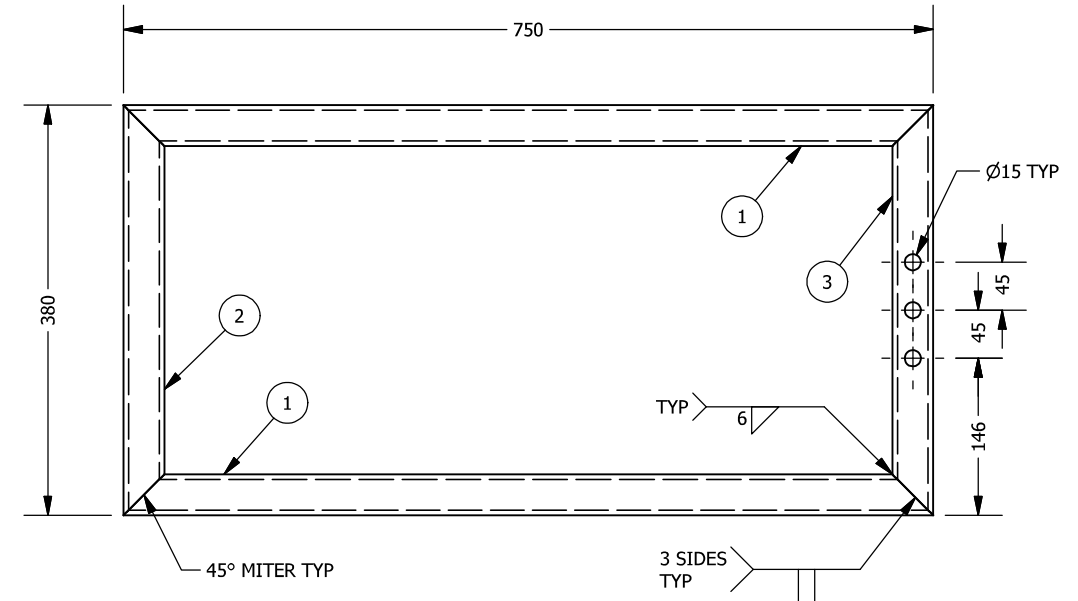

ITEM #4 DETAIL
GATE

GATE BILL OF MATERIALS						
ITEM	QTY	DESCRIPTION	SIZE	LENGTH	MATERIAL	FINISH
1	2	HORIZONTAL BAR	HSS - 1 1/2" x 1 1/2" x 1/4"	750	CSA G40.21 350W	GALVANIZED
2	1	VERTICAL BAR	HSS - 1 1/2" x 1 1/2" x 1/4"	380	CSA G40.21 350W	GALVANIZED
3	1	VERTICAL BAR BOLTED	HSS - 1 1/2" x 1 1/2" x 1/4"	380	CSA G40.21 350W	GALVANIZED



- GENERAL NOTES**
- FABRICATE AND ERECT STRUCTURAL STEEL TO CAN/CSA S16 LIMIT STATES DESIGN OF STEEL STRUCTURES.
 - ALL MATERIALS USED IN FABRICATION SHALL BE NEW, ACCOMPANIED BY MILL CERTIFICATES.
 - ALL EDGES SHOULD BE SMOOTH AND FREE FROM BURRS.
 - COMPLETE ASSEMBLIES SHALL BE HOT DIPPED GALVANIZED AS PER ASTM A123/A123M.

REV	DATE	DESCRIPTION
0	03/07/19	ISSUED FOR CONSTRUCTION

TOLERANCES & SURFACE FINISH - UNLESS OTHERWISE NOTED

FABRICATION	MACHINING	SURFACE FINISH
0 TO 600 ±1	X ±0.5	Ra = 3.2
>600 ±3	X,X ±0.1	
	X,XX ±0.01	

ALL DIMENSIONS IN mm UNLESS OTHERWISE NOTED.
DO NOT SCALE DRAWING

THIS DRAWING AND DESIGN IS THE PROPERTY OF McElhanney Consulting Services Ltd. (McElhanney) AND SHALL NOT BE USED, REUSED OR REPRODUCED WITHOUT THE CONSENT OF McElhanney.

McElhanney WILL NOT BE HELD RESPONSIBLE FOR THE IMPROPER OR UNAUTHORIZED USE OF THIS DRAWING AND DESIGN.

THIS DRAWING AND DESIGN HAS BEEN PREPARED FOR THE CLIENT IDENTIFIED, TO MEET THE STANDARDS AND REQUIREMENTS OF THE APPLICABLE PUBLIC AGENCIES AT THE TIME OF PREPARATION.

McElhanney, ITS EMPLOYEES, SUBCONSULTANTS AND AGENTS WILL NOT BE LIABLE FOR ANY LOSSES OR OTHER CONSEQUENCES RESULTING FROM THE USE OR RELIANCE UPON, OR ANY CHANGES MADE TO, THIS DRAWING, BY ANY THIRD PARTY, INCLUDING CONTRACTORS, SUPPLIERS, CONSULTANTS AND STAKEHOLDERS, OR THEIR EMPLOYEES OR AGENTS, WITHOUT McElhanney's PRIOR WRITTEN CONSENT.

McElhanney
McElhanney Consulting Services Ltd.

#203, 502 Bow Valley Trail
CANMORE AB, T1W 1N9
www.mcelhanney.com
PH (403) 609-3992

ENVIRONMENT CANADA
WATER SURVEY OF CANADA

LADDER GATE (HD)

DRAWING #
3136-17

PROJECT #
2531-36602

REV
0

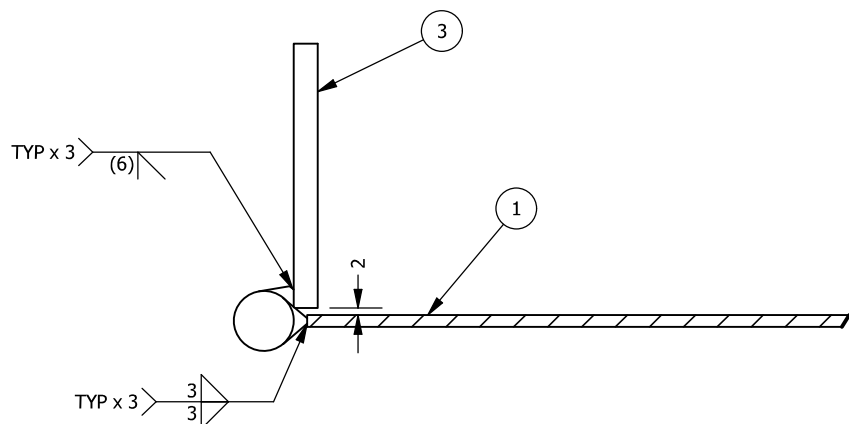
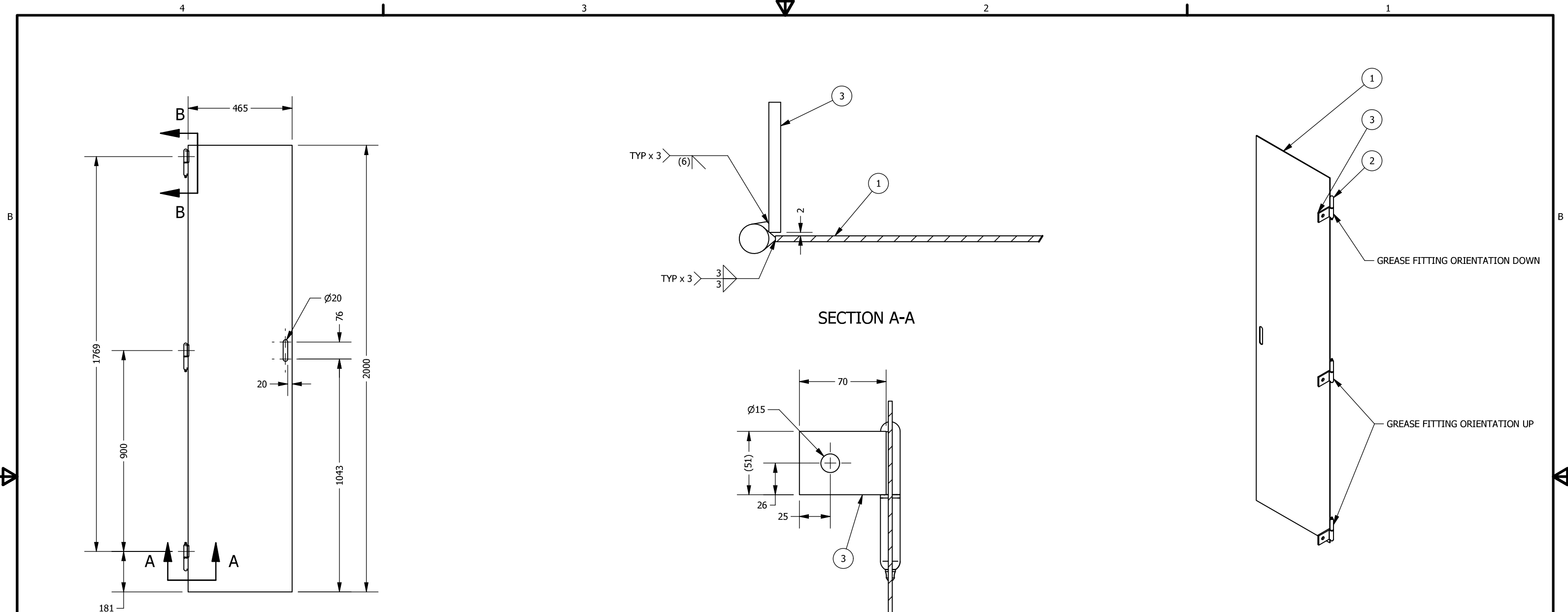

SECTION A-A

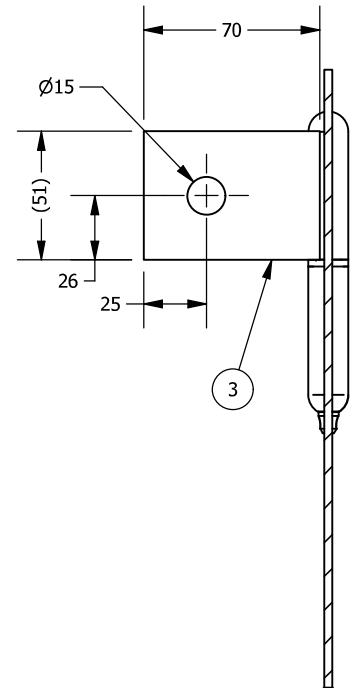

SECTION B-B

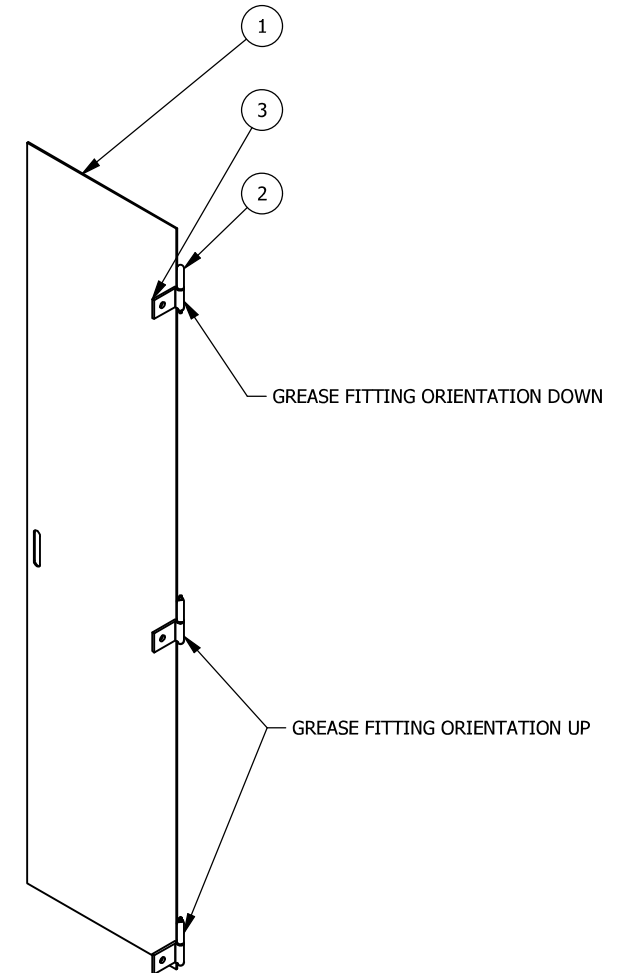

GENERAL NOTES

1. FABRICATE AND ERECT STRUCTURAL STEEL TO CAN/CSA S16 DESIGN OF STEEL STRUCTURES.
2. ALL MATERIALS USED IN FABRICATION SHALL BE NEW, ACCOMPANIED BY MILL CERTIFICATES.
3. ALL EDGES SHOULD BE SMOOTH AND FREE OF BURRS.
4. WELDING TO CONFORM TO CSA W-59 BY FABRICATORS CERTIFIED BY CANADIAN WELDING BUREAU (CWB) TO THE REQUIREMENTS OF CSA W47.1 DIVISION 1 OR 2.1. WELDS SHALL BE MADE WITH ELECTRODES AND FILLER MATERIAL RATED E480XX (E70XX) OR BETTER, UNLESS NOTED OTHERWISE.
5. DESIGNED TO FIT STANDARD A-FRAME LADDERS.
6. HINGE GREASE NIPPLE TO BE REMOVED AND HOLE AND SHAFT TO BE TAPPED OFF FOR GALVANIZING.

BILL OF MATERIALS

ITEM	QTY	DESCRIPTION	SIZE	LENGTH	MATERIAL	FINISH	DWG#
1	1	LADDER SECURITY GUARD PLATE	SHEET - 1/8"	465 x 2000	C1008/1010 HR	GALV	
2	3	WELD-ON HINGE W/ GREASE FITTING	2-5/16" X 5/8"		25/64" PIN DIA	LOW CARBON STEEL	
3	3	HINGE MOUNT	FLATBAR - 2" x 1/4"thk	70	CSA G40.21 300W	GALV	

REV	DATE	DESCRIPTION
0	29/NOV/2019	ISSUED FOR CONSTRUCTION

TOLERANCES & SURFACE FINISH - UNLESS OTHERWISE NOTED

FABRICATION	MACHINING	SURFACE FINISH
0 TO 600 ±1	X ±0.5	Ra = 3.2
>600 ±3	X,X ±0.1	
	X,XX ±0.01	

ALL DIMENSIONS IN mm UNLESS OTHERWISE NOTED.
DO NOT SCALE DRAWING

THIS DRAWING AND DESIGN IS THE PROPERTY OF McElhanney Ltd. (McElhanney) AND SHALL NOT BE USED, REUSED OR REPRODUCED WITHOUT THE CONSENT OF McELHANNEY.

McELHANNEY WILL NOT BE HELD RESPONSIBLE FOR THE IMPROPER OR UNAUTHORIZED USE OF THIS DRAWING AND DESIGN.

THIS DRAWING AND DESIGN HAS BEEN PREPARED FOR THE CLIENT IDENTIFIED, TO MEET THE STANDARDS AND REQUIREMENTS OF THE APPLICABLE PUBLIC AGENCIES AT THE TIME OF PREPARATION.

McELHANNEY, ITS EMPLOYEES, SUBCONSULTANTS AND AGENTS WILL NOT BE LIABLE FOR ANY LOSSES OR OTHER CONSEQUENCES RESULTING FROM THE USE OR RELIANCE UPON, OR ANY CHANGES MADE TO, THIS DRAWING, BY ANY THIRD PARTY, INCLUDING CONTRACTORS, SUPPLIERS, CONSULTANTS AND STAKEHOLDERS, OR THEIR EMPLOYEES OR AGENTS, WITHOUT McELHANNEY'S PRIOR WRITTEN CONSENT.

McElhanney
McElhanney Ltd.

#203, 502 Bow Valley Trail
CANMORE AB, T1W 1N9
www.mcelhanney.com
PH (403) 609-3962

Permit #06383

PROFESSIONAL ENGINEER ALBERTA
BRIAN BAIM
02 December 2019

ENVIROMENT CANADA

LADDER SECURITY GUARD

DRAWING #

3136-19

PROJECT #
2531-36604

REV
0