



# Solicitation ET025-222108/A

## Arctic Bay, Nunavut, Harbour Development – Bidders Conference

### Meeting Minutes

March 24, 2022

Time: 10:00 – 11:10 (CDT)

#### Location : Microsoft Teams

<i>Attendees:</i>	<i>Company</i>
Dan McRuer	Contracting Officer - Public Services and Procurement Canada
Kenton Thiessen	Project Manager – Public Services and Procurement Canada
Harald Kullmann	Advisian-Ikpiaryuk
DFO	Adele Butcher, Eleanor McEwan, Steven Kolt, Chris McDermid

#### Registered Contractors and Suppliers:

<b>Firm Name:</b>
Tower Arctic Ltd.
EBC Inc.
Dexter Construction Company Ltd.
Greenfield Construction and Mining Services
Pilitak Enterprises Ltd.
Luxton Construction
Ocean Group Inc.

1. Kenton Thiessen provided opening comments on the presentation format.
2. Kenton Thiessen welcomed the attendees, introduced the presenters, and provided a Land Acknowledgement.
3. Kenton Thiessen indicated that the purpose of the presentation is to present an overview of the Invitation to Tender documents, Inuit Benefits Plan, and Issued for Tender design documents. The presentation will not be presenting new items, but is intended to highlight key clauses and details, and encourage an open dialogue of the material. For the full description and content of the presented material, please refer to the posted solicitation documents. Kenton noted that the project team would attempt to address questions within the presentation format, or take questions away to provide responses through a tender amendment or addendum, depending on the



nature of the enquiry. Kenton noted that the presentation contains information related to the tender documents, but no part of the presentation is intended to add to or conflict with the posted documentation. If there are any discrepancies or conflicts noted, the attendees were asked to bring these to Kenton's attention.

4. Dan McRuer provided an overview of the solicitation document (please refer to the attached slides for more detail).
5. Kenton Thiessen provided an overview of the solicitation document, including the Inuit Benefits Plan (please refer to the attached slides for more detail).
6. Harald Kullmann provided an overview of the project and Specifications (please refer to the attached slides for more detail).
7. Harald Kullmann noted that there is a local Contractor in Arctic Bay that has construction equipment.
8. Kenton Thiessen noted that the presentation and minutes would be posted as an amendment in English and French.
9. Time was then given for questions and discussion. No questions or discussion topics were raised.

# Bidders Conference



## Arctic Bay Harbour Development

Solicitation Number:  
**ET025-222108**

Closing Date:  
**19 April 2022**

1

[www.pspc-spac.gc.ca](http://www.pspc-spac.gc.ca)



Public Services and  
Procurement Canada

Services publics et  
Approvisionnement Canada

Canada

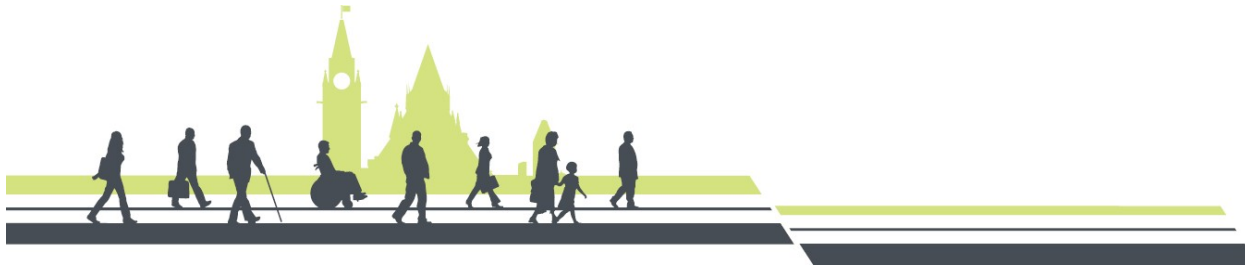

Serving  
GOVERNMENT,  
serving  
CANADIANS.

Au service du  
GOUVERNEMENT,  
au service des  
CANADIENS.

# Arctic Bay Harbour Development – Bidders Conference – 24 March 2022

---

Dan McRuer, Contracting Authority, Public Services and Procurement Canada

Kenton Thiessen, P.Eng., Project Manager, Public Services and Procurement Canada

Adele Butcher, P.Eng., Regional Engineer, Fisheries and Oceans Canada – Small Craft Harbours

Harald Kullmann, P.Eng, Consultant, Advisian-Ikpiaryuk

---

[www.pspc-spac.gc.ca](http://www.pspc-spac.gc.ca)



Public Services and  
Procurement Canada

Services publics et  
Approvisionnement Canada

Canada 

---

## **Contracting Authority:**

Dan McRuer

[dan.mcruer@pwgsc-tpsgc.gc.ca](mailto:dan.mcruer@pwgsc-tpsgc.gc.ca)

## **Solicitation Closing Date:**

Tuesday, April 19, 2022 at 2:00 pm (CDT)

3

[www.pspc-spac.gc.ca](http://www.pspc-spac.gc.ca)



Public Services and  
Procurement Canada

Services publics et  
Approvisionnement Canada

**Canada**

## Overview of Invitation to Tender (ITT)...

- Invitation to Tender with Inuit Benefits Plan (IBP).
- The responsive bid carrying the Highest Combined Rating of Inuit Benefits Plan (IBP) Commitment and Price will be recommended for contract award. See Appendix 6 Qualification Form [SI08]
- This procurement is subject to the Agreement Between the Inuit of the Nunavut Settlement Area and Her Majesty the Queen in Right of Canada (The Nunavut Agreement) [SI02]
- This requirement is limited to Inuit Firms on the Inuit Firm Registry (IFR).
- By submitting a bid, the Bidder certifies that they are or will be registered on the IFR prior to contract award.
- Canada will confirm if a Bidder is an Inuit Firm by searching the IFR prior to contract award. If the Bidder is not registered on the IFR, Canada will give the Bidder 5 business days in which to complete registration.
- If the Bidder does not comply with registration as an Inuit Firm on the IFR within the time frame provided, their bid will be declared non-responsive and given no further consideration.

[www.pspc-spac.gc.ca](http://www.pspc-spac.gc.ca)



Public Services and  
Procurement Canada

Services publics et  
Approvisionnement Canada

Canada

## ...Overview of Invitation to Tender (ITT)...

---

- Basis of Selection – The responsive bid carrying the Highest Combined Rating of Inuit Benefits Plan (IBP) Commitment and Price will be recommended for contract award. See Appendix 6 Qualification Form.
- Enquiries must only be directed to the Contracting Authority and should be received no later than 7 calendar days prior to the solicitation closing date. [SI03]
- Bids can be submitted by hard copy or by epost Connect. [SI07]



## ...Overview of Invitation to Tender (ITT)...

---

- Due to the impacts of the COVID-19 pandemic and to encourage physical distancing, the bid receiving unit in Winnipeg will remain open but with limited staff and limited hours: **Monday, Wednesday, Thursday and Friday, 9 am to 11 am, and Tuesday, 9 am to 2 pm (local time)**. Please monitor [buyandsell.gc.ca](http://buyandsell.gc.ca) closely as changes to bid closing dates may be necessary.





## ...Overview of Invitation to Tender (ITT)...

---

- The facsimile number for receipt of bid revisions is **1-418-566-6167**. [SI05]
- Bid Security – Bid Bond must be an original signed and sealed hard copy or an original electronic digital bond (E-Bond). A scanned copy of a bond does not constitute a digital bond. [SI06]



## ...Overview of Invitation to Tender (ITT)...

---

- Bid and Acceptance Form (BA) [pg 15]
  - Bid validity period is 45 days.
  - The Contractor must perform and complete the Work within 178 weeks from the date of notification of acceptance of the offer.
- Appendix 1 - Combined Price Form [pg 16-18]
  - Unit Price Table



## ...Overview of Invitation to Tender (ITT)...

---

- Appendix 2 - Integrity Provisions - List of Names [pg 19]
- Appendix 3 - Listing of Subcontractors and Suppliers. [pg 20]  
Must submit the completed table.
- Appendix 4 – COVID-19 Vaccination Requirement Certification [pg 21]
- Appendix 5 – Voluntary Certification to Support the Use of Apprentices [pgs 22-23]
- Appendix 6 – Qualification Form [pg 24]
- Appendix 7 – Inuit Benefits Plan (IBP) Nunavut Agreement [pgs 25-44]

[www.pspc-spac.gc.ca](http://www.pspc-spac.gc.ca)



Public Services and  
Procurement Canada

Services publics et  
Approvisionnement Canada

Canada 

## ...Overview of Invitation to Tender (ITT)

---

- Annex A – Certificate of Insurance [pgs 45-46]
  - Commercial General Liability
  - Builder’s Risk / Installation Floater
  - Pollution Liability
  - Marine Liability
- Annex B – Voluntary Report For Apprentices Employed During The Contract [pg 47]



## ...Overview of Invitation to Tender (ITT)

---

- Firms intending to submit bids on this project should obtain bid documents through the GETS service provider on the Government of Canada Web site at <http://buyandsell.gc.ca/procurement-data/tenders>. Firms that obtain bid documents from a source other than the official site run the risk of not receiving a complete package.



# ...Overview of Invitation to Tender (ITT)

- List of Interested Suppliers.
  - General contractors, sub-contractors and suppliers are encouraged to self-identify for this tender using the link on the BuyandSell.gc.ca tender notice page.
  - The Contracting Authority can email the link if firms are having difficulty locating it.

Buyandsell.gc.ca  
Public Services and Procurement Canada

Canada.ca | Services | Departments | Français

For Businesses | For Government | Goods and Services | Applications | Procurement Data

Home > Procurement Data > Tenders > Search > Arctic Bay, Nunavut, Harbour Development (ET025-222108/A)

### Arctic Bay, Nunavut, Harbour Development (ET025-222108/A)

**New! CanadaBuys is here! Suppliers register today!**  
Register now to ensure you transition to doing business with the new Government of Canada procurement service.  
[Click here to get started](#)

#### Tender Notice - Notice of Proposed Procurement (NPP)

Status	Active
Days until closing	1 month 5 days hence

Publication date	2022/03/04
Amendment date	None
Date closing	2022/04/19 14:00 Central Daylight Time (CDT)

GSIN	Region of delivery
5133C, Waterways, Harbours, Dams and Other Water Works	Nunavut
End user entity	Procurement entity
Public Works and Government Services Canada	Public Works and Government Services Canada

[Show more](#)

#### Description

Trade Agreement: CETA/WTO-AGP/CPTPP/CFTA/FTAs with Peru/Columbia/Panama/Korea/UK  
Tendering Procedures: All interested suppliers may submit a bid

Notifications  
Get notifications for this tender notice:  
For more information on notifications, visit the [Follow Opportunities](#) page.

Find out who is interested in this tender  
Are you looking for partnering opportunities or thinking about bidding? Find out who is interested in the tender and add your name to the List of Interested Suppliers.  
**Important:** The LIS for a specific tender notice does not replace or effect the tendering procedures in place for the procurement. Businesses are still required to respond to bid solicitations and to compete based on established bid criteria. For more information please read the [List of Interested Suppliers Terms of Use](#).

Access the List of Interested Suppliers for this tender  
[Arctic Bay, Nunavut, Harbour Development \(ET025-222108/A\) - List of Interested Suppliers](#)

www.pspc-spac.gc.ca



Public Services and  
Procurement Canada

Services publics et  
Approvisionnement Canada

Canada

# ...Overview of Invitation to Tender (ITT)

---

## GI13 (2020-05-28) Procurement Business Number

Suppliers are required to have a Procurement Business Number (PBN) before contract award. Suppliers may register for a PBN online at [Supplier Registration Information](#).

Please contact the Contracting Authority with any questions on how to register.



---

## **Departmental Representative:**

Kenton Thiessen

## **Solicitation Closing Date:**

Tuesday, April 19, 2022 at 2:00 pm (CDT)





# BID AND ACCEPTANCE FORM (BA)

---

- **BA04 BID VALIDITY PERIOD**
  - The bid must not be withdrawn for a period of **45 days** following the date of solicitation closing.
- **BA06 CONSTRUCTION TIME**
  - The Contractor must perform and complete the Work within **178 weeks** from the date of notification of acceptance of the offer.



# APPENDIX 1 – COMBINED PRICE TABLE

## APPENDIX 1 - COMBINED PRICE FORM

- **Lump Sum:**
  - Work included in the Lump Sum Amount represents all work not included in the unit price table
- **Unit Price Table:**
  - The Unit Price Table designates Work to which a Unit Price Arrangement applies. The Price per Unit shall not include any amounts for Work that is not included in that unit price Item
  - QEC cash allowance – QEC direct costs
- **Total Bid Amount = Lump Sum Amount + Total Extended Amount (unit prices)**

- 1) The prices per unit will govern in establishing the Total Extended Amount. Any arithmetical errors in this Appendix will be corrected by Canada.
- 2) Canada may reject the bid if any of the prices submitted do not reasonably reflect the cost of performing the part of the work to which that price applies.

### LUMP SUM

The Lump Sum Amount designates Work to which a Lump Sum Arrangement applies.

- (a) Work included in the Lump Sum Amount represents all work not included in the unit price table.

<b>LUMP SUM AMOUNT (LSA)</b> Excluding applicable tax(es)
--

### UNIT PRICE TABLE

The Unit Price Table designates Work to which a Unit Price Arrangement applies.

- (a) Work included in each item is as described in the referenced specification section.  
 (b) The Price per Unit shall not include any amounts for Work that is not included in that unit price Item.

Item	Specification Reference	Class of Labour, Plant or Material	Unit of Measurement	Estimated Quantity (EQ)	Price per Unit applicable tax(es) extra (PU)	Extended Amount (EQ x PU) applicable tax(es) extra
1	31 05 16 31 23 23	Breakwater - Type 1 Fill	cu.m	74985		
2	31 05 16 31 23 23 35 42 35	Breakwater - Type 1 Armour	cu.m	17220		
39	31 05 16 03 30 00 05 50 00	Floats - Anchor	ea.	26		
40	03 30 00 05 50 00 35 24 35	Floats - Abutment	ea.	5		
41	01 11 00	QEC Allowance	ea.	1	\$250,000.00	\$250,000.00
<b>TOTAL EXTENDED AMOUNT (TEA)</b> EXCLUDING APPLICABLE TAXE(S)						

<b>TOTAL BID AMOUNT (LSA +TEA)</b> Excluding applicable tax(es)
--

.ca



Public Services and  
Procurement Canada

Services publics et  
Approvisionnement Canada

Canada

# APPENDIX 4 – COVID-19 VACCINATION REQUIREMENT CERTIFICATION

- All personnel who access federal government workplaces within Canada where they may come into contact with public servants will be:
  - fully vaccinated against COVID-19;
  - for personnel that are unable to be vaccinated due to a certified medical contraindication, religion or other prohibited grounds of discrimination under the *Canadian Human Rights Act*, subject to accommodation and mitigation measures that have been presented to and approved by Canada; or
  - partially vaccinated against COVID-19 for a period of up to 10 weeks from the date of their first dose and subject to temporary measures that have been presented to and approved by Canada, immediately after which period the personnel will meet the conditions of (a) or (b) or will no longer access federal government workplaces where they may come into contact with public servants under this Contract;
- until such time that Canada indicates that the mandatory vaccination requirements of the Mandatory Vaccination Policy for Supplier Personnel are no longer in effect.



## APPENDIX 6 - QUALIFICATION FORM

- The selection will be based on the highest responsive combined rating of IBP commitment and price. The ratio will be **30%** for the IBP and **70%** for the price.

	Bidder 1	Bidder 2	Bidder 3	
<b>IBP Commitment Evaluation</b>				
Location in NSA	10/10 x 5 = 5.0	10/10 x 5 = 5.0	10/10 x 5 = 5.0	
Inuit Employment Score	26/40 x 10 = 6.50	28/40 x 10 = 7.0	31/40 x 10 = 7.75	
Inuit Ownership	22/40 x 5 = 2.75	20/40 x 5 = 2.5	30/40 x 5 = 3.75	
Inuit Training (hours commitment)	1.65/5 x 5 = 1.65	2.9/5 x 5 = 2.9	5/5 x 5 = 5.0	
Inuit Training (financial commitment)	1.65/5 x 5 = 1.65	2.9/5 x 5 = 2.9	5/5 x 5 = 5.0	
<b>Total IBP Commitment Score</b>	17.55/30	20.30/30	26.50/30	
<b>Bid Evaluated Price</b>	\$55,000.00	\$50,000.00	\$45,000.00	
<b>Calculations</b>	<b>IBP Commitment Score</b>	17.55	20.30	26.50
	<b>Pricing Score</b>	45/55 x 70 = 57.27	45/50 x 70 = 63.00	45/45 x 70 = 70.00
<b>Combined Rating</b>	74.82	83.30	96.50	
<b>Overall Ranking</b>	3rd	2nd	1st	

[www.pspc-spac.gc.ca](http://www.pspc-spac.gc.ca)



## APPENDIX 7 – INUIT BENEFITS PLAN – PART A

---

- Bidders must provide a written plan of engagements, measures and proposed procedures to be taken to deliver on the Inuit labour, training, and subcontracting/supplier commitments.
- **BIDDERS WILL ONLY BE ELIGIBLE TO RECEIVE POINTS FOR DEMONSTRATED COMMITMENTS.** Bidders must include all reference material to be considered. Only material and/or documents submitted as part of the bid proposal will be considered.
- Examples of what a bidder may provide to demonstrate their commitments is included in Part A (non exhaustive list)
- Definitions of Eligible Inuit labourer and IFR Firm – included in Part A



# APPENDIX 7 – INUIT BENEFITS PLAN CRITERIA – PART A

NUNAVUT BENEFITS CRITERIA (NBC)		
1.1	<p><b>LOCATION OF BUSINESS IN THE NSA:</b> Bidders are requested to demonstrate the existence of the vendor or sub-contractors performing work under the government contract have new or existing head offices, staffed administrative offices or other staffed facilities in the Nunavut Settlement Area.</p> <p>Points will be assigned as follows:</p> <ol style="list-style-type: none"> <li>1. Head Offices (3 pts)</li> <li>2. Staffed Administrative Offices (4 pts)</li> <li>3. Other Staffed Facilities (3 pts)</li> </ol> <p><b>This criterion is worth 5% of the Combined Rating points available, as described in Appendix 6.</b></p> <p>IBP Holdback Conditions will apply to this criterion.</p>	/10



# APPENDIX 7 – INUIT BENEFITS PLAN CRITERIA– PART A

INUIT BENEFITS CRITERIA (IBC)	
1.2	<p><b>EMPLOYMENT</b></p> <p>The employment of on-site Inuit in carrying out the work of the contract.</p> <p>Bidder will be evaluated on their firm commitment to use on-site Inuit from the Nunavut Settlement Area, as defined in Appendix 7, in carrying out the work. The percentages identified below relate specifically to on-site labour hours regardless of whether they are Prime Contractor staff and/or sub-contractor staff.</p> <p>Percentages should be supported by a list of specific positions, categories, overall percentage of labour, labour hours and the total project hours that may or will be staffed by on-site Inuit. On-site Inuit employment will be confirmed during activities based on supporting documentation provided by the Contractor and Departmental Representative, if applicable.</p> <p>An eligible Inuit labourer must meet the following criteria:</p> <ol style="list-style-type: none"> <li>1. An individual who is working on-site performing services related to the project for a contractor, sub-contractor or supplier who has a contract with PWGSC to do work related to the project; and</li> <li>2. An individual registered on the Nunavut Inuit Enrolment list</li> </ol> <p>0-100% of total site labour hours = 0 - 40 points.</p> <p>Points will be assigned based on a percentage % of the total points available:</p> <p>___ % (Labour Commitment) x total points available</p> <div style="border: 1px solid black; padding: 5px; margin: 10px 0;"> <p><i>Example:</i>  <i>Bidder commitments 65% of labour hours will be Inuit = 65% of total points (40)</i>  <i>65 % x 40 = 26 points</i></p> </div> <p><b>NOTE:</b>                      Bidder must demonstrate how they will meet their Labour %. Simply indicating a "%" commitment is not sufficient to achieve points.</p>
	<p>Eligible Inuit Employment commitments <b>must not include</b> any commitments already included under the Eligible Inuit Training commitments or the Inuit Ownership commitments.</p> <p><b>This criterion is worth 10% of the Combined Rating points available, as described in Appendix 6.</b></p> <p>IBP Holdback Conditions will apply to this criterion.</p>

/40



# APPENDIX 7 – INUIT BENEFITS PLAN CRITERIA– PART A

INUIT OWNERSHIP (SUB-CONTRACTORS / SUPPLIERS)	
1.3	<p>The use of IFR sub-contractors/suppliers in carrying out the contract.</p> <p>Bidders will be evaluated on their firm commitment to use IFR sub-contractors for services or the procurement of supplies and equipment from IFR businesses. Note: The total dollar value of the IFR contracting shall also include the Prime Contractor's share of the contract.</p> <p><b>An IFR sub-contractors or suppliers must meet the following criteria:</b></p> <p>An IFR Firm shall be a firm, the name of which appears on the most current list of Inuit firms created in accordance with the requirements of Article 24.7.1 of the Agreement between the Inuit of the Nunavut Settlement area and Her Majesty the Queen in Right of Canada.</p> <p>Bidders should provide their commitment of IFR sub-contractors or suppliers in accordance with the following:</p> <p>Value of IFR Contracting (Prime Contractor + sub-contractor or supplier): \$ _____ (a) +            Value of Non-IFR Contracting (Prime Contractor + sub-contractor or supplier): \$ _____ (b) =            Estimated value of IFR and non-IFR (prime contractor/subcontractor/supplier): \$ _____ (c)</p> <p><b>(a) / (c) = Inuit Ownership Commitment (%) (d)</b></p> <p>Points will be assigned based on a percentage of the total points available:</p> <p><b>(d) x ____ (available points) = assigned points</b></p> <div style="border: 1px solid black; padding: 5px; margin: 10px 0;"> <p><i>Example:</i></p> <p>Value of IFR contracting: \$ 55,000 (a)            Value of Non-IFR contracting: \$ 45,000 (b)            Estimated value of Contract: \$ 100,000 (c)</p> <p><math>\\$55,000 / \\$100,000 = .55</math>  <math>55\% \times 40 = 22 \text{ assigned points}</math></p> </div> <p>Inuit Ownership commitments <b>must not include</b> any commitments already included under the Eligible Inuit Training commitments or the Eligible Inuit Employment commitments.</p> <p><b>This criterion is worth 5% of the Combined Rating points available, as described in Appendix 6.</b></p> <p>IBP Holdback Conditions will apply to this criterion.</p>
	/40



# APPENDIX 7 – INUIT BENEFITS PLAN CRITERIA – PART A

## INUIT TRAINING AND SKILLS DEVELOPMENT

This criterion is worth 10% of the Combined Rating points available, as described in Appendix 6. (5% for hours commitment and 5% for financial commitment)

### Inuit Training and Skills Development – Hours Commitment

Bidders will be evaluated on their undertaking of a commitment with respect to delivery of on-the-job training, apprenticeship programs, and other applicable training programs for Inuit from the Nunavut Settlement Area.

- Bidders are to identify what on-the-job or in-house training will consist of, the category of work, estimated number of hours and number of persons to be trained.
- Apprenticeship and/or applicable training and skill development programs are considered delivered when the receiving individuals have acquired certifiable work skills. This is typically achieved through an independent third party certification process.
- Inuit participation in training and skill development programs that are included in the scope of the contract are not eligible for consideration.

Total Inuit Training and Skills Development hours: \_\_\_\_\_ (E1)

### Score Calculations: Commitment

1.4 For commitment, to establish the commitment score, each responsive bid will be prorated against the bidder proposing the highest commitment, where the proposal with the highest commitment receives full points. /5

Example	Bidder 1	Bidder 2	Bidder 3
Commitment (Hours)	20	35	60
Calculation of Points	20/60 = 33% of total points available	35/60 = 58% of total points available	60/60 = 100% of total points available

NOTE: Bidders should provide the total hours and dollar values by populating Table 4 below to detail the Inuit training and skills development hours and financial commitment. Simply indicating training and skills development hours and dollar values is not sufficient to achieve points.

Eligible Inuit Training commitments **must not include** any commitments already included under the Eligibility Inuit Employment commitments or Inuit Ownership commitments.

IBP Holdback Conditions will apply to this criterion.

# APPENDIX 7 – INUIT BENEFITS PLAN CRITERIA– PART A

1.5	<p><b>Inuit Training and Skills Development – Financial Commitment</b>                  Bidder will be evaluated on the total dollar value commitment to train and skill develop Inuit from the Nunavut Settlement Area, as defined in Appendix 7.</p> <p><b>Note:</b></p> <ul style="list-style-type: none"> <li>• Instructor rates, materials, and/ or other training/ skill development supplies required may be eligible for consideration.</li> <li>• External or third-party training costs may be eligible for consideration.</li> <li>• Labour rates for on-the-job or in-house training, apprenticeship, and/ or other training/ skill development that has already been captured in 1.2 On-Site Inuit Labour – Financial Commitment cannot be captured in this criteria again.</li> </ul> <p style="text-align: center;">Total dollar value of Inuit Training and Skills Development: \$ _____ (E2)</p> <p><b>Score Calculations: Commitment</b>                  For commitment, to establish the commitment score, each responsive bid will be prorated against the bidder proposing the highest commitment, where the proposal with the highest commitment receives full points.</p>	/5										
	<table border="1" style="width: 100%; border-collapse: collapse;"> <thead> <tr> <th style="text-align: left;"><u>Example</u></th> <th style="text-align: center;">Bidder 1</th> <th style="text-align: center;">Bidder 2</th> <th style="text-align: center;">Bidder 3</th> </tr> </thead> <tbody> <tr> <td><b>Commitment (\$ value)</b></td> <td style="text-align: center;">\$20,000.00</td> <td style="text-align: center;">\$35,000.00</td> <td style="text-align: center;">\$60,000.00</td> </tr> <tr> <td><b>Calculation of Points</b></td> <td style="text-align: center;">20/60 = 33% of total points available</td> <td style="text-align: center;">35/60 = 58% of total points available</td> <td style="text-align: center;">60/60 = 100% of total points available</td> </tr> </tbody> </table> <p>NOTE: Bidders should provide the total hours and dollar values by populating Table 4 below to detail the Inuit training and skills development hours and financial commitment. Simply indicating training and skills development hours and dollar values is not sufficient to achieve points.</p> <p>Eligible Inuit Training commitments <b>must not include</b> any commitments already included under the Eligibility Inuit Employment commitments or Inuit Ownership commitments.</p> <p>IBP Holdback Conditions will apply to this criterion.</p>		<u>Example</u>	Bidder 1	Bidder 2	Bidder 3	<b>Commitment (\$ value)</b>	\$20,000.00	\$35,000.00	\$60,000.00	<b>Calculation of Points</b>	20/60 = 33% of total points available
<u>Example</u>	Bidder 1	Bidder 2	Bidder 3									
<b>Commitment (\$ value)</b>	\$20,000.00	\$35,000.00	\$60,000.00									
<b>Calculation of Points</b>	20/60 = 33% of total points available	35/60 = 58% of total points available	60/60 = 100% of total points available									

# APPENDIX 7 – IBP BIDDER COMMITMENT AND CERTIFICATION – PART B

- At time of bid submission - The tables below may be used by bidders to submit their proposals and to supplement their response.

**TABLE 1 – Head Office**

Provide Current Business address		
Bidders to demonstrate the existence of head offices, staffed administrative offices or other staffed facilities in the Nunavut Settlement Area.		
Nature of Presence: Describe the nature of the firm's presence in the NSA and how it demonstrates progress towards, and maintenance of, commitments made in the NBC portion of the bidder's IBP.		
Vendor Name	Vendor Address in the NSA	Nature of Presence in the NSA (including office type: home, administrative or staffed facility)
Sub-contractor Name	Sub-contractor Address in the NSA	Nature of Presence in the NSA

25

[pspc-spac.gc.ca](http://pspc-spac.gc.ca)



# APPENDIX 7 – IBP BIDDER COMMITMENT AND CERTIFICATION – PART B

**TABLE 2 – On-site Inuit Labour Content Commitment**

Total No. Of on-site Inuit Employee Hours for This Contract = \_\_\_\_\_ %  
 Total Employee onsite Hours for This Contract

Position of Inuit Employee NOTE: It is not necessary to identify non-Inuit employees by position.	Type of Employment	Hourly Rate*	Total on-site Hours Worked	Total Dollar Value Paid
		\$		
		\$		
		\$		
		\$		
Total Inuit and non-Inuit Employee Hours				

Note: \*The hourly rate must be the dollar value paid in CAD to the Inuit employee for work performed under the government contract.

[www.pps-ps.gc.ca](http://www.pps-ps.gc.ca)



# APPENDIX 7 – IBP BIDDER COMMITMENT AND CERTIFICATION – PART B

**TABLE 3 – Inuit Sub-Contractor/Supplier Content Commitment**

Total Estimated Cost for Inuit Sub-Contractor/Supplier for This Contract = \_\_\_\_\_ %  
Total Bid Price

Company Name	Description of the Work	Inuit Firm ID (if an IFR Firm)	Value of Contractor portion of the contract, sub-contractor or Supplies / Services	Inuit Firm Registry Company	Non-Inuit Company
				<input type="checkbox"/> Yes	<input type="checkbox"/> Yes
				<input type="checkbox"/> Yes	<input type="checkbox"/> Yes
				<input type="checkbox"/> Yes	<input type="checkbox"/> Yes
				<input type="checkbox"/> Yes	<input type="checkbox"/> Yes
				<input type="checkbox"/> Yes	<input type="checkbox"/> Yes
				<input type="checkbox"/> Yes	<input type="checkbox"/> Yes
				<input type="checkbox"/> Yes	<input type="checkbox"/> Yes
				<input type="checkbox"/> Yes	<input type="checkbox"/> Yes
				<input type="checkbox"/> Yes	<input type="checkbox"/> Yes

NOTE: only sub-contractors and suppliers that can be confirmed as Inuit businesses on the Inuit Firm Registry (IFR) will be included in the calculations. Verification of Inuit businesses will be made in accordance with 1.3 INUIT OWNERSHIP (Sub-Contractor/Supplier)



# APPENDIX 7 – IBP BIDDER COMMITMENT AND CERTIFICATION – PART B

**TABLE 4 – Inuit Training and Skills Development Commitment**

Employment Type or Position	Type of Training and/or Skills Development	Number of Inuit to be Trained	Training and/or Skills Development Hours	Total Dollar Value
				\$
				\$
				\$
				\$
				\$
<b>Total</b>				(E1) \$ (E2)

[www.pspc-spac.gc.ca](http://www.pspc-spac.gc.ca)



Public Services and Procurement Canada Services publics et Approvisionnement Canada

Canada

## APPENDIX 7 – IBP REPORTING – PART C

---

1. The Contractor must provide a summary of activities undertaken to meet the commitments made as part of the Inuit Benefits Plan (IBP) portion of their bid. The Certification and Achievement tables below must be completed with supporting information (such as invoices, work logs, payroll receipts, etc.) by the Contractor with each progress claim. The information provided will be used for Part D – Assessment of IBP Holdback.



# APPENDIX 7 – IBP ASSESSMENT OF HOLDBACK– PART D

---

## **Holdback – for the non-performance of IBP commitments**

**Part C and D is for the successful Contractor only.**

The Contractor agrees to the application of an IBP Holdback when its IBP obligations are not being achieved.

In the event that IBP obligations are not being achieved by the Contractor, Canada may retain a percentage or amount of any progress payment(s), up to 2% of the progress payment value.

The total IBP Holdback may be retained by Canada under circumstances including but not limited to the following:

- a. Original IBP obligations, or modified IBP obligations approved in advance by Canada have not been delivered by the Contractor; or
- b. Canada determines that sufficient evidence has not been provided by the Contractor demonstrating that IBP commitments could not be delivered due to circumstances outside of the Contractor's control.

The total amount of portion(s) of any payment(s) subject to IBP Holdback remaining at the end of the Contract related to the Contractor's failure to meet its IBP obligations may be retained by Canada indefinitely.





# Project Overview and Key Contract Clauses

- Harald Kullmann, P.Eng, Advisian-Ikpiaryuk



Arctic Bay area

31

[www.pspc-spac.gc.ca](http://www.pspc-spac.gc.ca)

Canada 

# Project Overview



Harbour site

32

[www.pspc-spac.gc.ca](http://www.pspc-spac.gc.ca)



Public Services and  
Procurement Canada

Services publics et  
Approvisionnement Canada

Canada

# Project Overview



**New  
Quarry**

33

[www.pspc-spac.gc.ca](http://www.pspc-spac.gc.ca)



Public Services and  
Procurement Canada

Services publics et  
Approvisionnement Canada

**Canada**



# Project Overview

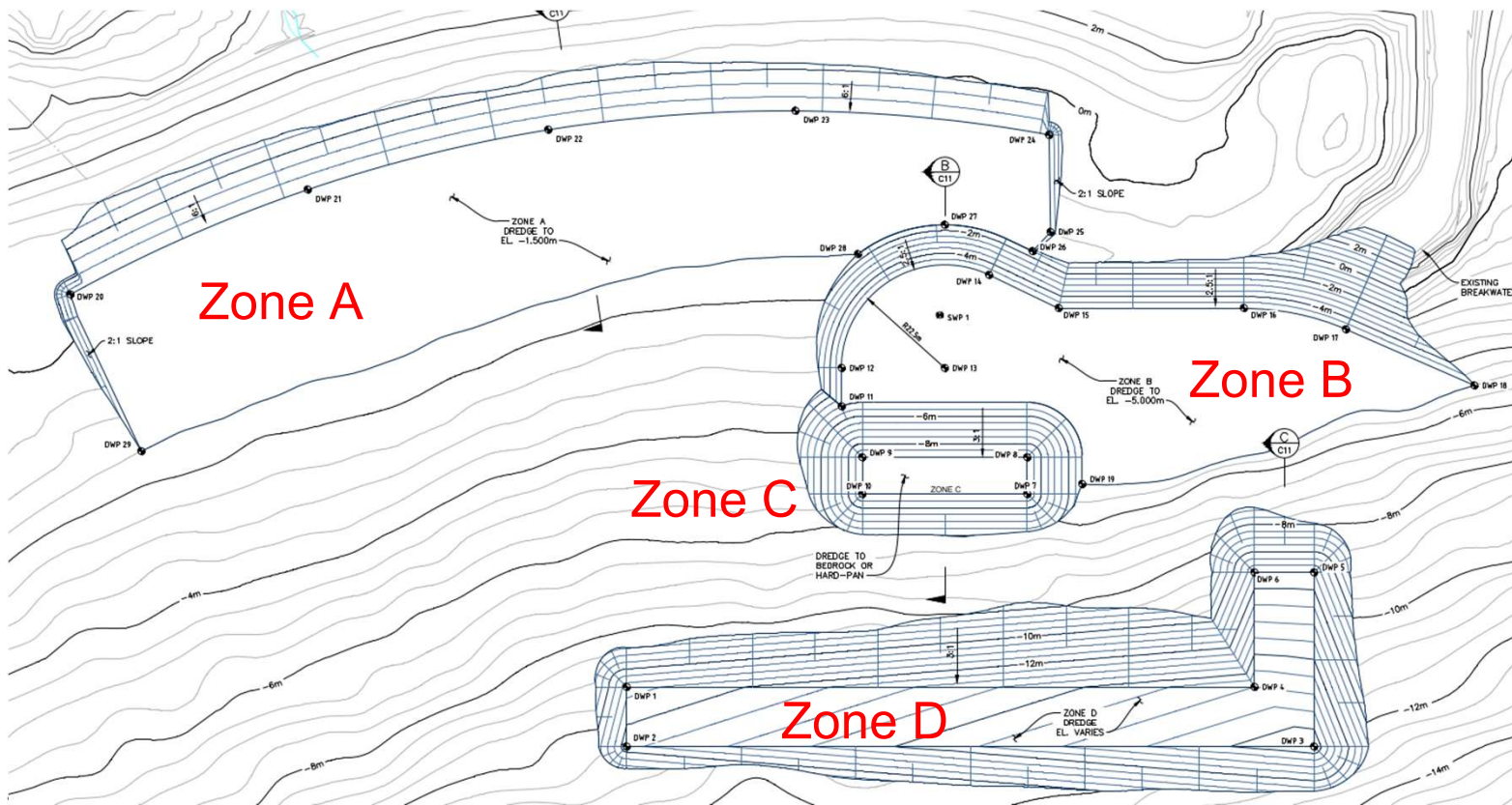

## Dredge Plan



# Project Overview

## Breakwater cross section

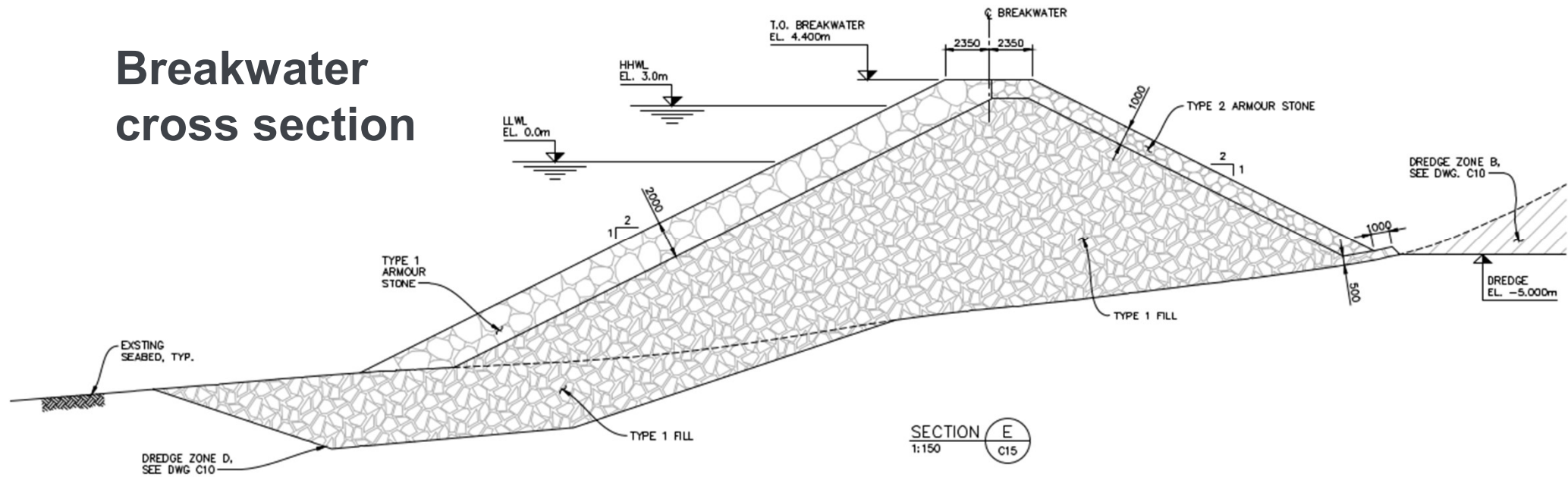

36

[www.pspc-spac.gc.ca](http://www.pspc-spac.gc.ca)



Public Services and  
Procurement Canada

Services publics et  
Approvisionnement Canada

Canada

# Project Overview

## Wharf cross section

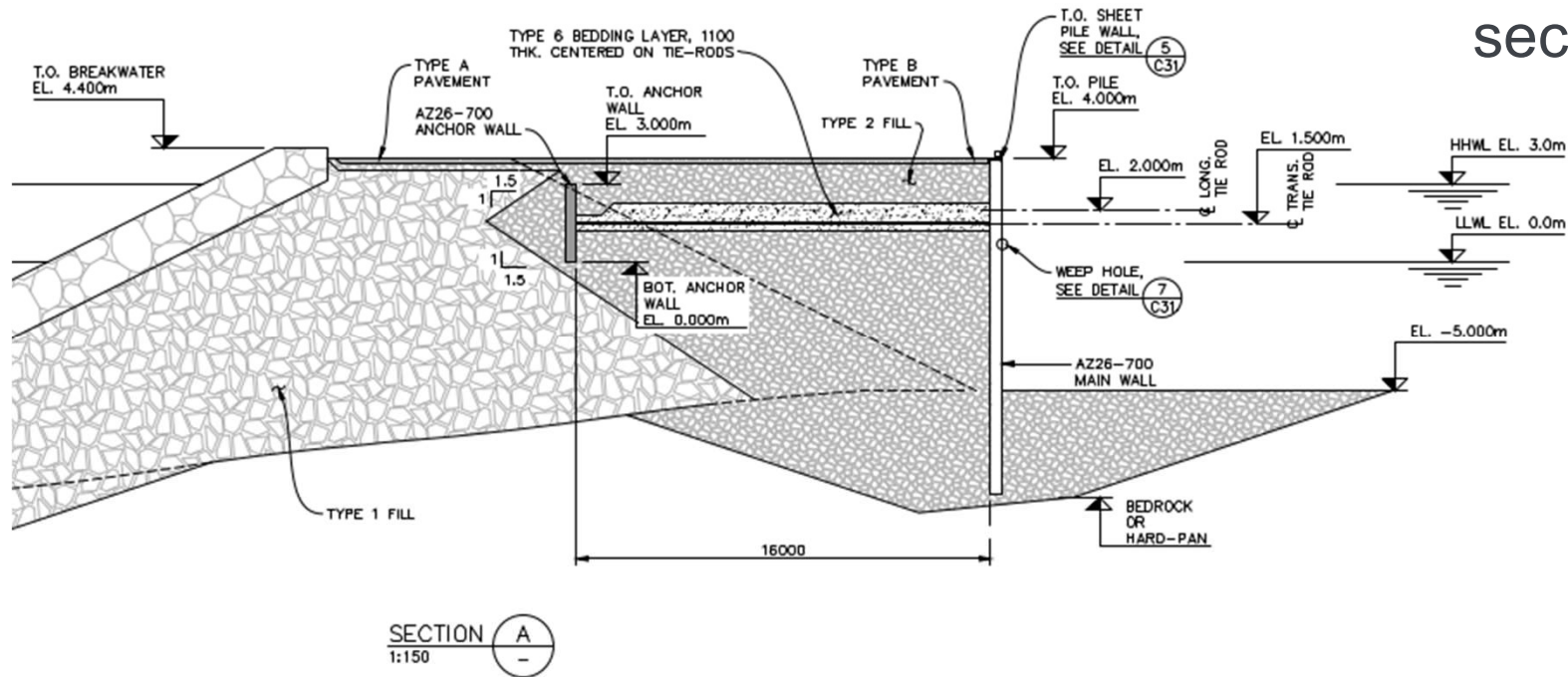

# Key Contract Clauses

---

## 01 11 00 – Summary of Work Article 3.1

- Do not disrupt boating activities at the beach area. Users are subsistence hunters.
- Do not disrupt dry cargo sealift operations.





## Key Contract Clauses

---

### 01 11 00 – Summary of Work

#### Article 3.3

- The existing roads are, in places, narrow, steep, have low level power lines, and have an abundance of pedestrians, including children.
- Existing roads are gravelly and dusty.

### 01 41 00 – Regulatory requirements

#### Article 1.13

- Contractor to deal with vehicle routing, flag-person support, areas of sensitivity, speed limits of 20 km/hr within the community, traffic awareness concerning road safety<sup>39</sup> particularly for children and teens, and DUST.

[www.pspc-spac.gc.ca](http://www.pspc-spac.gc.ca)



Public Services and  
Procurement Canada

Services publics et  
Approvisionnement Canada

Canada 

# Key Contract Clauses

---

## 01 11 00 – Summary of Work Article 3.6

- Archeological Survey:
  - Departmental Representative completing supplemental field program summer 2022.
  - Contractor to provide locations where additional surveys are required for his temporary works.
  - DR will submit to Culture and Heritage (C&H) on behalf of the Contractor.
  - Any additional surveys needed for C&H approval will be by Contractor.



# Key Contract Clauses

---

## 01 29 13 – Measurement and Payment

### Article 3.1

- Volume measurements: no measurement for:
  - Waste
  - Tolerance
  - Over-dredge
- Neat lines on the Drawings only



# Key Contract Clauses

---

## 01 35 43 – Environmental Procedures

### Article 2.12

- Departmental Representative has obtained the following permits:
  - NIRB Screening Decision Report
  - DFO, Fisheries Act Authorization
  - ECCC, Ocean Disposal Permit
  - CIRNAC Land Use Permits
  - Nunavut Water Board (NWB), Type B Licence
  - Transport Canada, Navigation Protection Program Permit.
  
- Contractor to obtain any other permits (including NWB for temporary works)



# Key Contract Clauses

---

## 01 35 43 – Environmental Procedures

### Article 2.1.3

- NIRB permit required a Construction Environmental Management Plan (CEMP) which is general.
- Contractor to make the CEMP into their own comprehensive executable plan (CCEMP)



# Key Contract Clauses

---

## 01 35 43 – Environmental Procedures

### Article 2.3

- Engage an environmental monitor (EM) independent professional EM, experienced in monitoring the impacts of marine construction on fish and fish habitat.
- EM to be applied scientist/technologist with at least 5 years experience in construction related environmental monitoring.
- EM to have no other role in the project.



## Key Contract Clauses

---

### 01 41 00 – Regulatory Requirements

#### Article 1.10.6

- Hold public information sessions twice per year. Ensure you include comments received and how issues/complaint are being addressed.
- At the start and end of each season, arrange to meet with the Hamlet and Hunters and Trappers Association. Walk the sites that the Contractor plans to affect.



## Key Contract Clauses

---

### 01 41 10 – Quarry and Pit Management Plan

#### Article 3.1

- Use an independent expert on developing the quarry to maximize yield for armour production. Adjust blasting to suit.
- Submit expert's report.
- Update procedures and report if changes in the quarry occur during development.





# Key Contract Clauses

---

## 01 52 00 – Construction Facilities

### Article 2.4

- Contractor is responsible for its fuel supply.
- If using local fuel, coordinate with the PPD. Local fuel capacity is strained.



## Key Contract Clauses

---

### 01 71 23 – Field Engineering Article 1.2

- Prior to starting construction each season, complete pre-construction topographic and bathymetric survey for the harbour site and quarry.





- **Solicitation Enquiries:** [Dan.McRuer@pwgsc-tpsgc.gc.ca](mailto:Dan.McRuer@pwgsc-tpsgc.gc.ca)

