



RETURN BIDS TO:

RETOURNER LES SOUMISSIONS À:

No of Page/ N° de page	_ 30
------------------------------	------

See Section 2.2
Voir Section 2.2

STANDARD REQUEST FOR BID

INVITATION À SOUMISSIONNER - STANDARD

The Bidder offers to provide to Canada the goods, services or both listed in the bid solicitation in accordance with the conditions set out in the bid solicitation and the prices set out in the bid.

This bid solicitation is issued in accordance with the conditions of the Supply Arrangement E60PQ-120001/G.

Le soumissionnaire offre de fournir au Canada les biens, services ou les deux énumérés dans la demande de soumissions aux conditions prévues dans la demande de soumissions et aux prix indiqués dans la soumission.

Cette demande de soumissions est émise conformément aux conditions de l'arrangement en matière d'approvisionnement E60PQ-120001/G.

Solicitation No. - N° de la demande	Amendment No. - N° de modification
100021664	1

Solicitation closes – La demande prend fin :	File No. - N° de dossier
at – à 14:00 July 7, 2022	
on – le 14:00 7 juillet, 2022	
See Section 2.3 Voir Section 2.3	

Date of Solicitation – Date de la demande

30 juin, 2022

June 30, 2022

Address inquiries to – Adresser toute demande de renseignement à :

Stephanie Luedee

NC-SOLICITATIONS-GD@hrsdc-rhdcc.gc.ca

Les soumissionnaires doivent s'assurer les e-mails ne dépassent pas 13 MB pour éviter les problèmes de transmission. /

Submission e-mails do not exceed 13MB to avoid problems with transmission.

Destination

See Annex B

Voir Annexe B

Instructions:

Municipal taxes are not applicable.

Unless otherwise specified in the bid solicitation, all prices quoted must be net prices in Canadian funds including Canadian customs duties, excise taxes, must be FOB, including all delivery charges to destination(s) as indicated. The amount for Applicable Taxes is to be shown as a separate item.

Instructions:

Les taxes municipales ne s'appliquent pas.

Sauf indication contraire dans la demande de soumissions, tous les prix indiqués doivent être des prix nets, en dollars canadiens, comprenant les droits de douane canadiens, la taxe d'accise et doivent être FAB, y compris tous frais de livraison à la (aux) destination(s) indiqué(s). Le montant des taxes applicables doit apparaître séparément.

Supplier Name and Address – Nom et adresse du fournisseur

Telephone No. - N° de téléphone

Facsimile No. - N° de télécopieur

Name and title of person authorized to sign on behalf of supplier (type or print)

Nom et titre de la personne autorisée à signer au nom du fournisseur (caractère d'impression)

Signature : _____ Date : _____

TABLE OF CONTENTS

PART 1 - GENERAL INFORMATION	2
1.1 SECURITY REQUIREMENTS	2
1.2 REQUIREMENT	2
1.3 GENERAL OR PROCUREMENT STRATEGY FOR INDIGENOUS BUSINESS (PSIB)	2
1.4 CANADIAN CONTENT	2
1.5 DEBRIEFINGS	2
PART 2 - BIDDER INSTRUCTIONS	3
2.1 STANDARD INSTRUCTIONS, CLAUSES AND CONDITIONS	3
2.2 SUBMISSION OF BIDS.....	3
2.3 ENQUIRIES - BID SOLICITATION.....	3
2.4 BID CHALLENGE AND RECOURSE MECHANISMS.....	4
PART 3 - BID PREPARATION INSTRUCTIONS	5
3.1 BID PREPARATION INSTRUCTIONS	5
PART 4 - EVALUATION PROCEDURES AND BASIS OF SELECTION	6
4.1 EVALUATION PROCEDURES.....	6
4.2 BASIS OF SELECTION.....	6
PART 5 – CERTIFICATIONS AND ADDITIONAL INFORMATION	7
5.1 CERTIFICATIONS REQUIRED WITH THE BID	7
5.2 CERTIFICATIONS PRECEDENT TO CONTRACT AWARD AND ADDITIONAL INFORMATION	7
PART 6 - RESULTING CONTRACT CLAUSES	9
6.1 SECURITY REQUIREMENTS	9
6.2 REQUIREMENT	9
6.3 STANDARD CLAUSES AND CONDITIONS.....	9
6.4 TERM OF CONTRACT	10
6.5 AUTHORITIES	11
6.6 PAYMENT	12
6.7 INVOICING INSTRUCTIONS	12
6.8 CERTIFICATIONS AND ADDITIONAL INFORMATION.....	13
6.9 APPLICABLE LAWS.....	13
6.10 PRIORITY OF DOCUMENTS	13
6.11 ACCESS TO FACILITIES AND EQUIPMENT	13
6.12 CANADA'S FACILITIES TO ACCOMMODATE THE DELIVERY	13
6.13 STANDARD FINISHES.....	14
6.14 SACC MANUAL CLAUSES	14
ANNEX A	15
REQUIREMENT.....	15
ANNEX B	19
BASIS OF PAYMENT	19
ANNEX C	25
SECURITY REQUIREMENTS CHECKLIST	25

PART 1 - GENERAL INFORMATION

1.1 Security Requirements

Contractor may be escorted; possession of a security clearance not required.

1.2 Requirement

This solicitation is issued pursuant to the Supplier's Furniture for Office Seating Supply Arrangement (SA) that forms part of the series of SAs issued by PWGSC with the number E60PQ-120001/PQ. The terms and conditions in the Supplier's SA apply to and form part of this solicitation. Bidders who submit a bid agree to be bound by those terms and conditions as well as the terms and conditions in this solicitation.

The requirement is detailed under Annex A of the resulting contract clauses.

1.3 General or Procurement Strategy for Indigenous Business (PSIB)¹

This requirement is a: *(the checked box applies)*

General Stream Procurement

The requirement is subject to all applicable trade agreements as identified in the Notice of Proposed Procurement (NPP).

PSIB Stream Procurement

This procurement is set aside under the federal government Procurement Strategy for Indigenous Business. For more information on Aboriginal business requirements of the Set-aside Program for Indigenous Business, refer to [Annex 9.4](#) of the Supply Manual.

1.4 Canadian Content

The requirement is limited to Canadian goods.

1.5 Debriefings

Bidders may request a debriefing on the results of the bid solicitation process. Bidders should make the request to the Contracting Authority within 15 working days from receipt of the results of the bid solicitation process. The debriefing may be in writing, by telephone or in person.

¹ Procurement Strategy for Indigenous Business (PSIB) replaces Procurement Strategy for Aboriginal Business (PSAB)

PART 2 - BIDDER INSTRUCTIONS

2.1 Standard Instructions, Clauses and Conditions

All instructions, clauses and conditions identified in the bid solicitation by number, date and title are set out in the [Standard Acquisition Clauses and Conditions Manual](https://buyandsell.gc.ca/policy-and-guidelines/standard-acquisition-clauses-and-conditions-manual) (<https://buyandsell.gc.ca/policy-and-guidelines/standard-acquisition-clauses-and-conditions-manual>) issued by Public Works and Government Services Canada.

Bidders who submit a bid agree to be bound by the instructions, clauses and conditions of the bid solicitation and accept the clauses and conditions of the resulting contract.

The [2003](#) (2022-03-29) Standard Instructions - Goods or Services - Competitive Requirements, are incorporated by reference into and form part of the bid solicitation.

Subsection 5.4 of [2003](#), Standard Instructions - Goods or Services - Competitive Requirements, is amended as follows:

Delete: 60 days
Insert: 90 days

Subsection 3.a) of Section 01, Integrity Provisions - Bid of the Standard Instructions [2003](#) incorporated by reference above is deleted in its entirety and replaced with the following:

- a. at the time of submitting an arrangement under the Request for Supply Arrangements (RFSAs), the Bidder has already provided a list of names, as requested under the [Ineligibility and Suspension Policy](#). During this procurement process, the Bidder must immediately inform Canada in writing of any changes affecting the list of names.

2.2 Submission of Bids

Bids must be submitted only to the Employment and Social Development Canada (ESDC) Bid Receiving Unit specified below by the date and time indicated on page 1 of the bid solicitation:

Due to the nature of the bid solicitation, bids transmitted by facsimile to ESDC will not be accepted.

2.3 Enquiries - Bid Solicitation

All enquiries must be submitted in writing to the Contracting Authority no later than **2** calendar days before the bid closing date. Enquiries received after that time may not be answered.

Bidders should reference as accurately as possible the numbered item of the bid solicitation to which the enquiry relates. Care should be taken by Bidders to explain each question in sufficient detail in order to enable Canada to provide an accurate answer. Technical enquiries that are of a proprietary nature must be clearly marked "proprietary" at each relevant item. Items identified as "proprietary" will be treated as such except where Canada determines that the enquiry is not of a proprietary nature. Canada may edit the question(s) or may request that the Bidder do so, so that the proprietary nature of the question(s) is eliminated, and the enquiry can be answered to all Bidders. Enquiries not submitted in a form that can be distributed to all Bidders may not be answered by Canada.

2.4 Bid Challenge and Recourse Mechanisms

- (a) Several mechanisms are available to potential suppliers to challenge aspects of the procurement process up to and including contract award.
- (b) Canada encourages suppliers to first bring their concerns to the attention of the Contracting Authority. Canada's [Buy and Sell](#) website, under the heading "[Bid Challenge and Recourse Mechanisms](#)" contains information on potential complaint bodies such as:
- Office of the Procurement Ombudsman (OPO)
 - Canadian International Trade Tribunal (CITT)
- (a) Suppliers should note that there are **strict deadlines** for filing complaints, and the time periods vary depending on the complaint body in question. Suppliers should therefore act quickly when they want to challenge any aspect of the procurement process.

PART 3 - BID PREPARATION INSTRUCTIONS

3.1 Bid Preparation Instructions

Canada requests that Bidders provide their full company name and address, e-mail address, as well as contact name, and telephone number.

Canada requests that bidders provide their bid in separate files, in soft copy, as follows:

- Section I: Technical Bid - 1 soft copy via e-mail;
- Section II: Financial Bid - 1 soft copy via e-mail;
- Section III: Certifications - 1 soft copy via e-mail.

Prices must appear in the Financial Bid only. No prices must be indicated in any other section of the bid.

Canada requests that Bidders follow the format instructions described below in the preparation of soft copy of their bid:

- (a) use 8.5 x 11 inch (216 mm x 279 mm) sizing;
- (b) use a numbering system that corresponds to the bid solicitation.

Section I: Technical Bid

In their Technical Bid, Bidders should explain and demonstrate how they propose to meet the requirements and how they will carry out the Work.

Section II: Financial Bid

Bidders must submit their Financial Bid in accordance with the Basis of Payment.

3.1.1 Exchange Rate Fluctuation

C3011T (2013-11-06), Exchange Rate Fluctuation

Section III: Certifications and Additional Information

Bidders must submit the certifications and additional information required under Part 5.

PART 4 - EVALUATION PROCEDURES AND BASIS OF SELECTION

4.1 Evaluation Procedures

- (a) Bids will be assessed in accordance with the entire requirement of the bid solicitation including the technical and financial evaluation criteria.
- (b) An evaluation team composed of representatives of Canada will evaluate the bids.
- (c) The evaluation team will determine if there are two (2) or more bids with a valid Canadian content certification with the bids coming from two or more Bidders that are not affiliated within the meaning used in the *Competition Act*, R.S.C., 1985, c. C-34. In that event, only those bids with a valid certification will be eligible to be awarded a contract; otherwise, all bids will be eligible. If at any point in the evaluation process it is found, whether by determination of invalidity of certifications, determination that bids are non-responsive or withdrawal of bids by Bidders, that there are no longer two (2) or more responsive bids with a valid certification, then all responsive bids will be eligible to be awarded a contract. Canada may conduct the validation of Canadian content certifications at any time in the evaluation process including doing so concurrently with other steps.

4.1.1 Financial Evaluation

SACC Manual Clause [A0220T](#) (2014-06-26), Evaluation of Price-Bid

The price of the bid will be evaluated in Canadian dollars, Applicable Taxes excluded, FOB destination, Canadian customs duties and excise taxes included.

4.2 Basis of Selection

SACC Manual clause [A0069T](#) (2007-05-25) Basis of Selection

A bid must comply with all requirements of the bid solicitation to be declared responsive. The responsive bid with the lowest evaluated price will be recommended for award of a contract.

PART 5 – CERTIFICATIONS AND ADDITIONAL INFORMATION

Bidders must provide the required certifications and additional information to be awarded a contract.

The certifications provided by Bidders to Canada are subject to verification by Canada at all times. Unless specified otherwise, Canada will declare a bid non-responsive, or will declare a contractor in default if any certification made by the Bidder is found to be untrue whether made knowingly or unknowingly, during the bid evaluation period or during the contract period.

The Contracting Authority will have the right to ask for additional information to verify the Bidder's certifications. Failure to comply and to cooperate with any request or requirement imposed by the Contracting Authority will render the bid non-responsive or constitute a default under the Contract.

5.1 Certifications Required with the Bid

Bidders must submit the following duly completed certifications as part of their bid.

5.1.1 Integrity Provisions - Additional Information

Integrity checks were performed on each Supplier at time of issuance of their respective Supply Arrangement (SA). By submitting a bid, the Bidder certifies that the Bidder and its Affiliates are in compliance with the provisions as stated in Section 01 Integrity Provisions - Bid of Standard Instructions listed above.

5.1.2 Product Conformance

By submitting a bid, the Bidder certifies that all goods proposed conform, and will continue to conform throughout the period of the contract, to the requirement detailed under Annex A and to the Specifications of the series of SAs issued by PWGSC with the number E60PQ-120001/PQ.

5.1.3 Continuance of Certifications

The Bidder certifies that by submitting a bid in response to this solicitation, the Bidder, and any of the Bidder's members if the Bidder is a Joint Venture, continues to comply with all of the certifications submitted with its arrangement to become qualified as part of the series of SAs issued by PWGSC with the number E60PQ-120001/PQ.

5.2 Certifications Precedent to Contract Award and Additional Information

The certifications and additional information listed below should be submitted with the bid, but may be submitted afterwards. If any of these required certifications or additional information is not completed and submitted as requested, the Contracting Authority will inform the Bidder of a time frame within which to provide the information. Failure to provide the certifications or the additional information listed below within the time frame provided will render the bid non-responsive.

5.2.1 Federal Contractors Program for Employment Equity - Bid Certification

By submitting a bid, the Bidder certifies that the Bidder, and any of the Bidder's members if the Bidder is a Joint Venture, is not named on the Federal Contractors Program (FCP) for employment equity "FCP Limited Eligibility to Bid" list available at the bottom of the page of the [Employment and Social Development Canada \(ESDC\) - Labour's](https://www.canada.ca/en/employment-social-development/programs/employment-equity/federal-contractor-program.html#) website (<https://www.canada.ca/en/employment-social-development/programs/employment-equity/federal-contractor-program.html#>).

Canada will have the right to declare a bid non-responsive if the Bidder, or any member of the Bidder if the Bidder is a Joint Venture, appears on the "FCP Limited Eligibility to Bid" list at the time of contract award.

5.2.2 Additional Certifications Precedent to Contract Award

5.2.2.1 Price Certification

This certification applies to Competitive and Non-Competitive Requirements when the Total Evaluated Bid Price is \$50,000.00 or more and the bid is the only responsive bid.

a. Price Certification – Canadian-based Suppliers (other than Agency and Resale Outlets)

The Bidder certifies that the price proposed

- i. is not in excess of the lowest price charged anyone else, including the Bidder's most favoured customer, for the like quality and quantity of the goods, services or both;
- ii. does not include an element of profit on the sale in excess of that normally obtained by the Bidder on the sale of goods, services or both of like quality and quantity, and
- iii. does not include any provision for discounts to selling agents.

b. Price Certification – Canadian Agency and Resale Outlets

The Bidder certifies that the price proposed

- i. is not in excess of the lowest price charged anyone else, including the Bidder's most favoured customer, for the like quality and quantity of the goods, services or both; and does not include an element of profit on the sale in excess of that normally obtained by the Bidder on the sale of goods, services or both of like quality and quantity.

PART 6 - RESULTING CONTRACT CLAUSES

The following clauses and conditions apply to and form part of any contract resulting from the bid solicitation.

6.1 Security Requirements

6.1.1 Contractor may be escorted; possession of security clearance not required.

Contractor personnel MAY NOT ENTER NOR PERFORM WORK ON sites where PROTECTED or CLASSIFIED information or assets are kept, without an escort provided by the department or agency for which the work is being performed.

6.1.2 The following security requirements (SRCL and related clauses provided by the Contract Security Program) apply to and form part of the Contract:

1. The Contractor/Offeror must, at all times during the performance of the contract/standing offer, hold a valid Designated Organization Screening (DOS) certificate issued by the Contract Security Program (CSP), Public Works and Government Services Canada (PWGSC).
2. Contractor/Offeror personnel requiring access to restricted work sites must have a valid Reliability Status or be accompanied at all times.
3. Subcontracts with security requirements must not be awarded without prior written approval from Canada Employment and Social Development.

6.2 Requirement

6.2.1 The Contractor must provide office seating in accordance with the Requirement at Annex A.

This contract is issued against the Supplier's Furniture for Office Seating Supply Arrangement (SA) that forms part of the series of SAs issued by PWGSC with the number E60PQ-120001/PQ. The terms and conditions in the Supplier's SA apply to and form part of this contract.

6.2.2 This requirement is a

General Stream

PSIB² Stream

6.3 Standard Clauses and Conditions

All clauses and conditions identified in the Contract by number, date and title are set out in the [Standard Acquisition Clauses and Conditions Manual](https://buyandsell.gc.ca/policy-and-guidelines/standard-acquisition-clauses-and-conditions-manual) (https://buyandsell.gc.ca/policy-and-guidelines/standard-acquisition-clauses-and-conditions-manual) issued by Public Works and Government Services Canada.

² Procurement Strategy for Indigenous Business (PSIB) replaces Procurement Strategy for Aboriginal Business (PSAB)

6.3.1 General Conditions

2010A (2022-01-28), General Conditions - Goods (Medium Complexity), apply to and form part of the Contract.

Section 09 - Warranty, is amended as follows:

At Sub-section 1.

Deleted: "The warranty period will be 12 months."

Inserted: "The warranty period will be 10 years with the exception of user adjustable components, which will have a warranty of 5 years."

At Sub-section 2.

Deleted: In its entirety

Inserted: as follows:

2. The Contractor must pay the transportation cost associated with returning the Work or any part of the Work to the Contractor's plant for replacement, repair or making good. The Contractor must also pay the transportation cost associated with forwarding the replacement or returning the Work or part of the Work when rectified to the delivery point specified in the Contract or to another location as directed by Canada. If, in the opinion of Canada, it is not expedient to remove the Work from its location, the Contractor must carry out any necessary repair or making good of the Work at that location. In such cases, the Contractor will be responsible for all Costs (including travel and living expenses) incurred in so doing, Canada will not reimburse these Costs."

All other provisions of the warranty section remain in effect.

Section 16 - Interest on Overdue Accounts

This provision will not apply to payments made by credit card at point of sale. This provision does not apply to Suppliers whose SAs do not include the provision for payment by credit card.

6.4 Term of Contract

6.4.1 Period of the Contract

The period of the Contract is from date of Contract award to March 31, 2022.

6.4.2 Delivery Date

All the deliverables must be received by July 8, 2022.

6.4.3 Shipping Instructions

If delivery is required: Goods must be delivered DDP (Destination as specified in contract) Incoterms® rules, Applicable Taxes extra.

In addition to the above, the Contractor is to unload and move the goods to the delivery location(s) specified in the contract.

6.4.4 Delivery and Installation Points Location(s)

Delivery and Installation of the requirement will be made at the point(s) specified at Annex B of the Contract.

The Project Authority (PA) will provide the Supplier the authority to proceed prior to the finalized delivery and installation date taking into consideration the delivery and installation time provided by the Supplier. Canada will not be responsible if the Supplier chooses to proceed without the PA authorization.

6.5 Authorities

6.5.1 Contracting Authority

The Contracting Authority for the Contract is: *(to be completed at contract award)*

Name: _____

Title: _____

Department: _____

Address: _____

Telephone: ____ _

E-mail address: _____

The Contracting Authority is responsible for the management of the Contract and any changes to the Contract must be authorized in writing by the Contracting Authority. The Contractor must not perform work in excess of or outside the scope of the Contract based on verbal or written requests or instructions from anybody other than the Contracting Authority.

6.5.2 Project Authority

The Project Authority for the Contract is: *(to be completed at contract award)*

Name: _____

Title: _____

Organization: _____

Address: _____

Telephone: ____ _

E-mail address: _____

The Project Authority is the representative of the department or agency for whom the Work is being carried out under the Contract including the provision to approve the authority to proceed for delivery and installation and is responsible for all matters concerning the technical content of the Work under the Contract. Technical matters may be discussed with the Project Authority, however the Project Authority has no authority to authorize changes to the scope of the Work. Changes to the scope of the Work can only be made through a contract amendment issued by the Contracting Authority.

In addition, the PA is also responsible for ensuring that the Supplier's employees and subcontractors requiring access to the site adhere to the allocated time for the Supplier to access the site to deliver and install the furniture in accordance with the master schedule held by the General Contractor (a representative of Canada or a service provider(s) under contract with the Government of Canada).

6.5.3 Contractor's Representative

The Contractor's Representative for the Contract is: *(to be completed at contract award)*

Name: _____

Title: _____

Telephone: _____

E-mail address: _____

6.6 Payment

6.6.1 Basis of Payment

In consideration of the Contractor satisfactorily completing all of its obligations under the Contract, the Contractor will be paid firm unit price(s), as specified in Annex B – Basis of Payment, for a cost of \$_____ *(to be filled in only at contract award)*. Customs duties are included and Applicable Taxes are extra.

Canada will not pay the Contractor for any design changes, modifications or interpretations of the Work, unless they have been approved, in writing, by the Contracting Authority before their incorporation into the Work.

6.6.2 Method of Payment

SACC Manual clause H1001C (2008-05-12) Multiple Payment

Canada will pay the Contractor upon completion and delivery of units in accordance with the payment provisions of the Contract if:

- a) an accurate and complete invoice and any other documents required by the Contract have been submitted in accordance with the invoicing instructions provided in the Contract;
- b) all such documents have been verified by Canada;
- c) the Work delivered has been accepted by Canada.

6.6.3 SACC Manual Clauses

SACC Manual clause C0100C (2010-01-11) Discretionary Audit - Commercial Goods and/or Services

6.6.4 Electronic Payment of Invoices – Contract

Canada may pay invoices by credit card if the Contractor's SA indicates acceptance of such payment. Refer to Supplier's SA.

6.7 Invoicing Instructions

The Contractor must submit invoices in accordance with the section entitled "Invoice Submission" of the general conditions.

Invoices must be distributed as follows:

- a. The original and one (1) copy must be forwarded to the following address for certification and payment. *(To be completed at contract award)*
_____ *(Insert the name of the organization)*
_____ *(Insert the address of the organization)*

6.8 Certifications and Additional Information

6.8.1 Compliance

Unless specified otherwise, the continuous compliance with the certifications provided by the Contractor in its bid or precedent to contract award, and the ongoing cooperation in providing additional information are conditions of the Contract and failure to comply will constitute the Contractor in default. Certifications are subject to verification by Canada during the entire period of the Contract.

6.9 Applicable Laws

As set out in the article "Applicable Laws" in Part 6A of the SA.

6.10 Priority of Documents

If there is a discrepancy between the wording of any documents that appear on the list, the wording of the document that first appears on the list has priority over the wording of any document that subsequently appears on the list.

- (a) the Articles of Agreement of the SA E60PQ-120001;
- (b) the Articles of this Agreement;
- (c) the general conditions 2010A (2022-01-28) – General Conditions: Goods (Medium Complexity);
- (d) Annex A, Requirement;
- (e) Annex B, Basis of Payment;
- (f) Annex C, Additional Specifications and Certifications for NSA Products;
- (g) Annex D, Security Requirement;
- (h) the Contractor's bid dated _____ **(to be completed at contract award)**

6.11 Access to Facilities and Equipment

Canada's facilities, equipment, documentation and personnel are not automatically at the disposal of the Contractor. If access to government premises, computer systems (micro computer network), working space, telephones, terminals, documentation and personnel for consultation is required by the Contractor to perform the Work, the Contractor must advise the Contracting Authority of the need for such access in a timely fashion. If the Contractor's request for access is approved by Canada and arrangements are made to provide access to the Contractor, the Contractor, its subcontractors, agents and employees must comply with all the conditions applicable at the Work site. The Contractor must further ensure that the facilities and equipment are used solely for the performance of the Contract.

6.12 Canada's Facilities to Accommodate the Delivery

The Supplier's employees and subcontractors requiring access to the site must adhere to the health and safety plans established for the site, in addition to any laws in effect in the jurisdiction where the work is being performed.

During the period of the contract, a representative of Canada or a service provider(s) under contract with the Government of Canada may request the list of employees and subcontractors requiring access to the site to perform the work and their security statuses. Information must be provided in the timeframe prescribed in order to ensure that the supply, delivery and installation of the furniture aligns with the master schedule

6.13 Standard finishes

The Identified User (IU) will consult the Supplier's Website identified in Part 6A of the SA to view the available finishes.

Within ten business days of the contract award, the Project Authority will provide the Contractor with a written notice of Canada's finish choices for each of the product(s) in Annex A.

The Contractor will deliver the products corresponding to Canada's choice of specific finishes(s). No additional charge will be applied to Canada.

6.14 SACC Manual Clauses

SACC Manual clause [A9068C](#) (2010-01-11), Government Site Regulations

SACC Manual clause [G1005C](#) (2016-01-28), Insurance - No Specific Requirement

**ANNEX A
REQUIREMENT**

Table A1: Service Area Armrest-Free Chairs

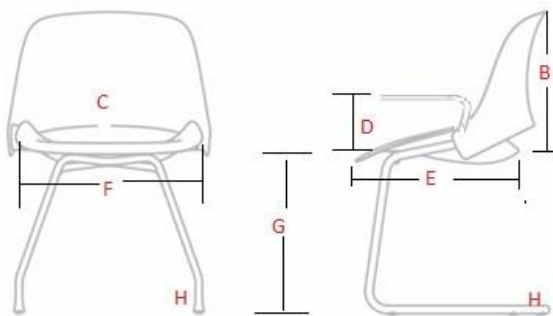
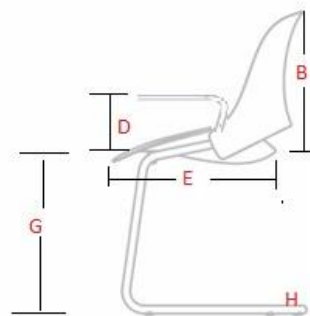
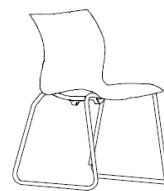
			<p>Side Chair</p> <p>QTY: <u>535</u></p> <p>Armrest-free chairs for service areas with hard-surfaced to facilitate maintenance</p>
<p>Note: dimensions reflect Specifications for Office Seating (SA)</p>			

Continuance of Certifications and additional information:

Canada may request copies of any SA certification(s) or additional information to confirm/review chair criteria of product proposed prior to contract award within a time period specified by the Identified User.

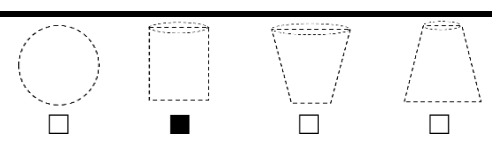
	Criteria <i>Instructions</i>	Requirement Choices <i>(dimensions reflect Specifications for Office Seating (SA))</i>	
	B <i>Backrest Height</i>	Standard = minimum height of 354 mm (13.9 in)	
	B <i>Backrest Style Preference(s)</i> <i>choose ALL that are acceptable</i>	<input type="checkbox"/> No preference <i>note: style represents overall shape, design may vary</i>	
	C <i>Lumbar Support</i> <i>choose only 1</i>	<input checked="" type="checkbox"/> Yes <input type="checkbox"/> No <input type="checkbox"/> No preference	
	D <i>Armrests</i> <i>choose only 1</i>	<input type="checkbox"/> Yes <input checked="" type="checkbox"/> No	
	E <i>Seat Depth</i> <i>choose only 1</i>	Fixed	<input type="checkbox"/> Shallow = 380 mm (15.0 in.) to 420 mm (16.5 in.) <input checked="" type="checkbox"/> Medium = greater than 420 mm (16.5 in.) to 460 mm (18.1 in.) <input type="checkbox"/> Deep = greater than 460 mm (18.1 in.)
	F <i>Seat Width</i>	17.0 in	
	G <i>Seat Height</i>	Fixed = between 417 mm (16.4 in.) and 512 mm (20.2 in.)	
	H <i>Stacking:</i> <i>choose only 1</i>	<input type="checkbox"/> Horizontal (nesting) <input checked="" type="checkbox"/> Vertical <input type="checkbox"/> No preference	

<p><i>Base Style</i></p> <p><i>choose ALL that are acceptable</i></p>	<p><input type="checkbox"/> Legs (4 post) <input type="checkbox"/> Casters <input type="checkbox"/> Glides</p> <p><input checked="" type="checkbox"/> Sled <input type="checkbox"/> Cantilever <input type="checkbox"/> Other _____</p>	
<p><i>Finishes (Upholstery / Non-Upholstery)</i></p> <p><i>choose ALL that are acceptable</i></p>	<p>Backrest</p> <p>Seat</p>	<p><input type="checkbox"/> Upholstery <input checked="" type="checkbox"/> Hard surface to facilitate maintenance (ex. hard plastic)_ <input type="checkbox"/> Breathable material (Mesh)</p> <p><input type="checkbox"/> Upholstery <input checked="" type="checkbox"/> Hard surface to facilitate maintenance (ex. hard plastic)_ <input type="checkbox"/> Breathable material (Mesh)</p>
<p>Additional Criteria:</p>	<ul style="list-style-type: none"> • Color: black • Weight 17 lbs • Delivery: The chairs must be assembled 	
<p>Delivery address and quantity to be delivered</p>	<ul style="list-style-type: none"> • Address 1 : <ul style="list-style-type: none"> ○ 2089, boulevard Marcel-Laurin, suite 100, St-Laurent, H4R 1K4 ○ Quantity : 194 chairs • Address 2 : <ul style="list-style-type: none"> ○ 740 rue Bel-Air, Montreal, H4X 2K3 ○ Quantity : 341 chairs 	
<p>Photo example</p>		

Table A2: Service Area Chairs with Armrests



Continuance of Certifications and additional information:

Canada may request copies of any SA certification(s) or additional information to confirm/review chair criteria of product proposed prior to contract award within a time period specified by the Identified User.

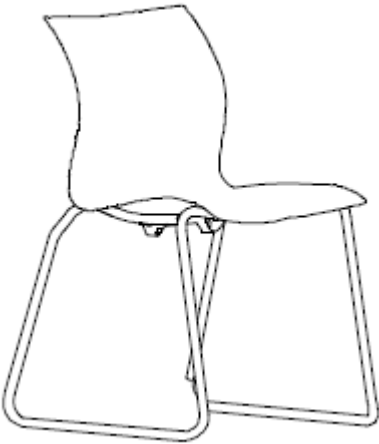
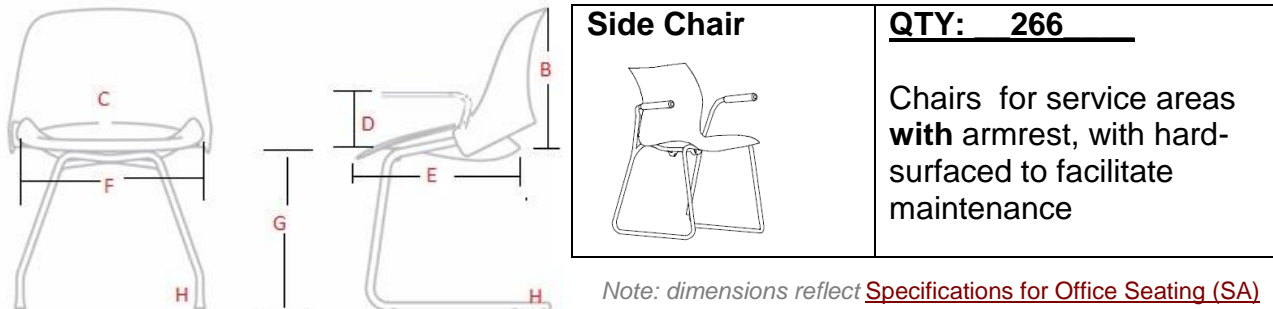
	Criteria <i>Instructions</i>	Requirement Choices <i>(dimensions reflect Specifications for Office Seating (SA))</i>
	Backrest Height	Standard = minimum height of 354 mm (13.9 in)
B	Backrest Style Preference(s) <i>choose ALL that are acceptable</i>	<input type="checkbox"/> No preference <i>note: style represents overall shape, design may vary</i>
C	Lumbar Support <i>choose only 1</i>	<input checked="" type="checkbox"/> Yes <input type="checkbox"/> No <input type="checkbox"/> No preference
D	Armrests <i>choose only 1</i>	<input checked="" type="checkbox"/> Yes <input type="checkbox"/> No
E	Seat Depth <i>choose only 1</i>	Fixed <input type="checkbox"/> Shallow = 380 mm (15.0 in.) to 420 mm (16.5 in.) <input checked="" type="checkbox"/> Medium = greater than 420 mm (16.5 in.) to 460 mm (18.1 in.) <input type="checkbox"/> Deep = greater than 460 mm (18.1 in.)
F	Seat Width	Standard = 17 in
G	Seat Height	Fixed = between 417 mm (16.4 in.) and 512 mm (20.2 in.)
	Stacking: <i>choose only 1</i>	<input type="checkbox"/> Horizontal (nesting) <input checked="" type="checkbox"/> Vertical <input type="checkbox"/> No preference
H	Base Style <i>choose ALL that are acceptable</i>	<input type="checkbox"/> Legs (4 post) <input type="checkbox"/> Casters <input type="checkbox"/> Glides <input checked="" type="checkbox"/> Sled <input type="checkbox"/> Cantilever <input type="checkbox"/> Other _____

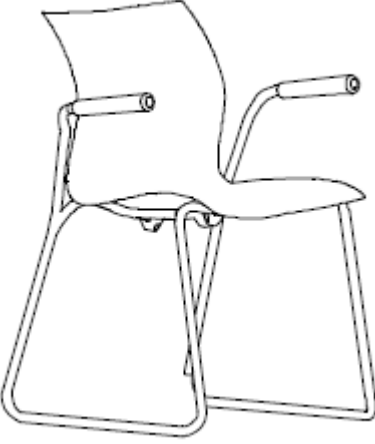
<p><i>Finishes (Upholstery / Non-Upholstery)</i></p> <p><i>choose ALL that are acceptable</i></p>	<p>Backrest</p>	<p><input type="checkbox"/> Upholstery <input checked="" type="checkbox"/> Hard surface to facilitate maintenance (ex. good quality hard plastic) <input type="checkbox"/> Breathable material (Mesh)</p>
	<p>Seat</p>	<p><input type="checkbox"/> Upholstery <input checked="" type="checkbox"/> Hard surface to facilitate maintenance (ex. good quality hard plastic) <input type="checkbox"/> Breathable material (Mesh)</p>
<p>Additional Criteria:</p>	<ul style="list-style-type: none"> • Color: black • Weight 17 lbs approx. • Delivery: The chairs must be assembled 	
<p>Delivery address and quantity to be delivered</p>	<ul style="list-style-type: none"> • Address 1 : <ul style="list-style-type: none"> ○ 2089, boulevard Marcel-Laurin, suite 100, St-Laurent, H4R 1K4 ○ Quantity : 96 chairs • Address 2 : <ul style="list-style-type: none"> ○ 740 rue Bel-Air, Montreal, H4X 2K3 ○ Quantity : 170 chairs 	
<p>Photo example</p>		

**ANNEX B
BASIS OF PAYMENT**

1. Procurement Strategy

- Subcategory Procurement
- All-inclusive Procurement with an estimated value of \$65,390.00

2. Product and Pricing

INSTRUCTIONS TO BIDDERS: Bidders are to complete Sections B of the tables identified by the IU in this article as well as Tables 5, 8 and 9. **Bidders must provide a complete product offering for each Subcategory or All-inclusive Procurement.** In a resulting contract, the term “Bid” means the Supplier’s commitment, the term “Bidder” means “Contractor”.

BIDDER TO COMPLETE SECTION B – SUPPLIER’S BID IN ITS ENTIRETY.

SUB-CATEGORY

Table 1: Summary of Chairs per Subcategory No. 1
(insert description if applicable).

Section A - IU REQUIREMENT			Section B – SUPPLIER’S BID		
Table	Title	Qty (A)	Supplier Part Number	Firm Unit Price \$ (B)	Extended Total [(A) Qty x (B) Price] \$
A1	Service Area Armrest-Free Chairs	535		\$	\$
A2	Service Area Chairs with Armrests	266		\$	\$
Subtotal Products:					\$

Table 2 – Delivery

(Standard Lead time is between 6-10 weeks for furniture delivery and installation)

Section A - IU REQUIREMENT				Section B – SUPPLIER'S BID	
Product Item # from Table 1	Location	Desired Date** (YYYY-MM-DD)	Desired Time: Normal Business Hours Or Outside Normal Business Hours *	Supplier will supply and deliver as per below**	Firm Lot Price \$
A1	Service Area Armrest-Free Chairs 2089, boulevard Marcel-Laurin, suite 100 St-Laurent, H4R 1K4 Quantity : 194 chairs	July 8, 2022	Outside	_____ : weeks <i>Standard Lead time is between 6-10 weeks for furniture delivery and installation.</i>	\$
A1	Service Area Armrest-Free Chairs 740 rue Bel-Air, Montreal, H4X 2K3 Quantity : 341 chairs	July 8, 2022	Outside	_____ : weeks <i>Standard Lead time is between 6-10 weeks for furniture delivery and installation.</i>	\$
A2	Service Area Chairs with Armrests 2089, boulevard Marcel-Laurin, suite 100, St-Laurent, H4R 1K4 Quantity : 96 chairs	July 8, 2022	Outside	_____ : weeks <i>Standard Lead time is between 6-10 weeks for furniture delivery and installation.</i>	\$
A2	Service Area Chairs with Armrests 740 rue Bel-Air, Montreal, H4X 2K3 Quantity : 170 chairs	July 8, 2022	Outside	_____ : weeks <i>Standard Lead time is between 6-10 weeks for furniture delivery and installation.</i>	\$
*Normal Business Hours 8:00 – 17:00, as per SA, Annex A, article 5					
**The Project Authority (PA) will provide the supplier the authority to proceed prior to the finalized delivery date taking into consideration the delivery time provided by the supplier. Canada will not be responsible if the supplier chooses to proceed without the PA authorization.				Delivery Total:	\$

Table 4 – Optional Product Not Applicable

Table 5 – Optional Delivery Not Applicable

Table 6 – Optional Installation Not Applicable

Table 7 – Standard Finishes and Canada’s Facilities to Accommodate the Delivery and Certifications

1.	Standard Finishes	
1.1	<p>IU is to consult the Supplier’s Website identified in Part 6A of the SA to view the available finishes.</p> <p>Within ten business days of the contract award, the Project Authority will provide the Contractor with a written notice of Canada’s finish choices for each of the product(s) in Annex A.</p> <p>The Contractor will deliver the products corresponding to Canada’s choice of specific finishes(s). No additional charge will be applied to Canada.</p>	
2.	Canada’s Facilities to Accommodate the Delivery	
	<p><i>The Supplier’s employees and subcontractors requiring access to the site must adhere to the health and safety plans established for the site, in addition to any laws in effect in the jurisdiction where the work is being performed.</i></p> <p><i>During the period of the contract, a representative of Canada or a service provider(s) under contract with the Government of Canada may request the list of employees and subcontractors requiring access to the site to perform the work and their security statuses. Information must be provided in the timeframe prescribed in order to ensure that the supply, delivery and installation of the furniture aligns with the master schedule.</i></p>	
2.1	Loading Dock/Location – Blvd. Marcel-Laurin	
A	Location	2089, boulevard Marcel-Laurin, suite 100, Saint-Laurent, Québec, H4R 1K4
B	Dock	NO, ground floor
C	Lift	Does not exist
D	Door	N/A
E	Freight Elevator	No
F	Other (specify, if any)	Driver must contact to make arrangements for delivery.
3.	Continuance of Certifications	
	<p>The Bidder certifies that by submitting a bid in response to the RFB, the Bidder, and any of the Bidder’s members if the Bidder is a Joint Venture, continues to comply with all of the following certifications listed in Parts 6A and 6B of the Bidder’s SA for Work Spaces.</p> <p>Canada may request copies of environmental certification(s) prior to contract award within a time period specified by the Identified User.</p>	
3.1	Integrity Provisions	
3.2	Federal Contractor’s Program for Employment Equity	
3.4	Product Conformance	
3.5	Price Certification (In accordance with the SA, Part 6B)	

Table 8 – Standard Finishes and Canada’s Facilities to Accommodate the Delivery and Certifications

1.	Standard Finishes	
1.1	<p>IU is to consult the Supplier’s Website identified in Part 6A of the SA to view the available finishes.</p> <p>Within ten business days of the contract award, the Project Authority will provide the Contractor with a written notice of Canada’s finish choices for each of the product(s) in Annex A.</p> <p>The Contractor will deliver the products corresponding to Canada’s choice of specific finishes(s). No additional charge will be applied to Canada.</p>	
2.	Canada’s Facilities to Accommodate the Delivery	
	<p><i>The Supplier’s employees and subcontractors requiring access to the site must adhere to the health and safety plans established for the site, in addition to any laws in effect in the jurisdiction where the work is being performed.</i></p> <p><i>During the period of the contract, a representative of Canada or a service provider(s) under contract with the Government of Canada may request the list of employees and subcontractors requiring access to the site to perform the work and their security statuses. Information must be provided in the timeframe prescribed in order to ensure that the supply, delivery and installation of the furniture aligns with the master schedule.</i></p>	
2.1	Loading Dock/Location – Entrepôt Régional\Service Canada	
A	Location	Entrepôt Régional\Service Canada ÉDIFICE NORMAND MAURICE 740, rue Bel-Air Montréal, QC. H4X 2K3
B	Dock	Yes, maximum height 53’ by 740 Bel-Air street, Montréal, QC, H4C 2K3, 1125
C	Lift	No
D	Door	Entrance doors accept 53’ trucks, and a height of 15’.
E	Freight Elevator	No
F	Other (specify, if any)	<p>Make arrangements for delivery. The supplier must contact the persons in charge of the warehouse</p> 

Table 8 – Standard Finishes and Canada’s Facilities to Accommodate the Delivery and Certifications Cont’d

3.	Continuance of Certifications
	The Bidder certifies that by submitting a bid in response to the RFB, the Bidder, and any of the Bidder’s members if the Bidder is a Joint Venture, continues to comply with all of the following certifications listed in Parts 6A and 6B of the Bidder’s SA for Work Spaces. Canada may request copies of environmental certification(s) prior to contract award within a time period specified by the Identified User.
3.1	Integrity Provisions
3.2	Federal Contractor’s Program for Employment Equity
3.4	Product Conformance
3.5	Price Certification (In accordance with the SA, Part 6B)

Table 9 - Bid Evaluation and Contract Total
(Canada may complete if not completed by the Bidder)

1	Firm Product Total (Table 1)	\$
2	Firm Delivery Total (Table 2)	\$
3	Total Evaluated (Bid) Price* (1 + 2) <i>[to be removed at contract award]</i>	\$
4	Applicable Tax(es): <i>[applicable at contract award only]</i>	\$
5	Total Estimated Cost (3 + 4): <i>[applicable at contract award only]</i>	\$

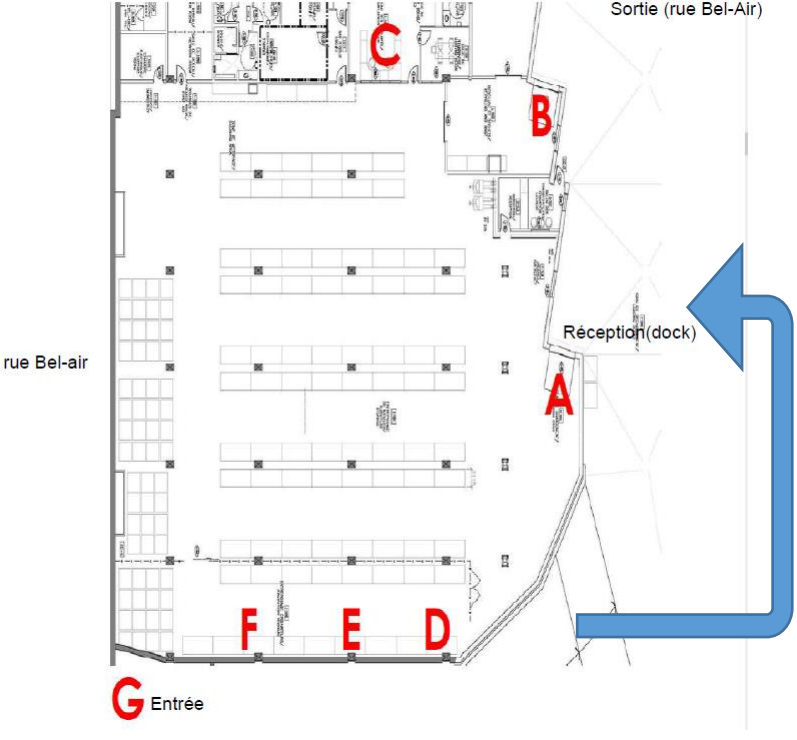
* Applicable taxes extra.

Table 10 – Bidder’s Authorized Representative

1.	Bidder's Authorized Representative for the Bid and the Contract	
	Name:	Telephone:
		E-Mail:
		PBN:

ANNEX C
SECURITY REQUIREMENTS CHECKLIST



**SECURITY REQUIREMENTS CHECK LIST (SRCL)
LISTE DE VÉRIFICATION DES EXIGENCES RELATIVES À LA SÉCURITÉ (LVERS)**

PART A - CONTRACT INFORMATION / PARTIE A - INFORMATION CONTRACTUELLE		
1. Originating Government Department or Organization / Ministère ou organisme gouvernemental d'origine EDSC - ESDC		2. Branch or Directorate / Direction générale ou Direction DGAPF - GIBR
3. a) Subcontract Number / Numéro du contrat de sous-traitance	3. b) Name and Address of Subcontractor / Nom et adresse du sous-traitant	
4. Brief Description of Work / Brève description du travail Achat des chaises pour la salle d'attente - dans le cadre du projet ACHATS URGENTS PPT **CSC St-Laurent: les chaises seront livrées et entreposées en dessous des chapiteaux dans une zone sécurisée		
5. a) Will the supplier require access to Controlled Goods? Le fournisseur aura-t-il accès à des marchandises contrôlées?		<input checked="" type="checkbox"/> No / Non <input type="checkbox"/> Yes / Oui
5. b) Will the supplier require access to unclassified military technical data subject to the provisions of the Technical Data Control Regulations? Le fournisseur aura-t-il accès à des données techniques militaires non classifiées qui sont assujetties aux dispositions du Règlement sur le contrôle des données techniques?		<input checked="" type="checkbox"/> No / Non <input type="checkbox"/> Yes / Oui
6. Indicate the type of access required / Indiquer le type d'accès requis		
6. a) Will the supplier and its employees require access to PROTECTED and/or CLASSIFIED information or assets? (Specify the level of access using the chart in Question 7. c) (Préciser le niveau d'accès en utilisant le tableau qui se trouve à la question 7. c)		<input checked="" type="checkbox"/> No / Non <input type="checkbox"/> Yes / Oui
6. b) Will the supplier and its employees (e.g. cleaners, maintenance personnel) require access to restricted access areas? No access to PROTECTED and/or CLASSIFIED information or assets is permitted. Le fournisseur et ses employés (p. ex. nettoyeurs, personnel d'entretien) auront-ils accès à des zones d'accès restreintes? L'accès à des renseignements ou à des biens PROTÉGÉS et/ou CLASSIFIÉS n'est pas autorisé.		<input type="checkbox"/> No / Non <input checked="" type="checkbox"/> Yes / Oui
6. c) Is this a commercial courier or delivery requirement with no overnight storage? S'agit-il d'un contrat de messagerie ou de livraison commerciale sans entreposage de nuit?		<input checked="" type="checkbox"/> No / Non <input type="checkbox"/> Yes / Oui
7. a) Indicate the type of information that the supplier will be required to access / Indiquer le type d'information auquel le fournisseur devra avoir accès		
Canada <input type="checkbox"/>	NATO / OTAN <input type="checkbox"/>	Foreign / Étranger <input type="checkbox"/>
7. b) Release restrictions / Restrictions relatives à la diffusion		
No release restrictions Aucune restriction relative à la diffusion <input checked="" type="checkbox"/>	All NATO countries Tous les pays de l'OTAN <input type="checkbox"/>	No release restrictions Aucune restriction relative à la diffusion <input type="checkbox"/>
Not releasable À ne pas diffuser <input type="checkbox"/>		
Restricted to: / Limité à : <input type="checkbox"/>	Restricted to: / Limité à : <input type="checkbox"/>	Restricted to: / Limité à : <input type="checkbox"/>
Specify country(ies): / Préciser le(s) pays :	Specify country(ies): / Préciser le(s) pays :	Specify country(ies): / Préciser le(s) pays :
7. c) Level of information / Niveau d'information		
PROTECTED A PROTÉGÉ A <input type="checkbox"/>	NATO UNCLASSIFIED NATO NON CLASSIFIÉ <input type="checkbox"/>	PROTECTED A PROTÉGÉ A <input type="checkbox"/>
PROTECTED B PROTÉGÉ B <input type="checkbox"/>	NATO RESTRICTED NATO DIFFUSION RESTREINTE <input type="checkbox"/>	PROTECTED B PROTÉGÉ B <input type="checkbox"/>
PROTECTED C PROTÉGÉ C <input type="checkbox"/>	NATO CONFIDENTIAL NATO CONFIDENTIEL <input type="checkbox"/>	PROTECTED C PROTÉGÉ C <input type="checkbox"/>
CONFIDENTIAL CONFIDENTIEL <input type="checkbox"/>	NATO SECRET NATO SECRET <input type="checkbox"/>	CONFIDENTIAL CONFIDENTIEL <input type="checkbox"/>
SECRET SECRET <input type="checkbox"/>	COSMIC TOP SECRET COSMIC TRÈS SECRET <input type="checkbox"/>	SECRET SECRET <input type="checkbox"/>
TOP SECRET TRÈS SECRET <input type="checkbox"/>		TOP SECRET TRÈS SECRET <input type="checkbox"/>
TOP SECRET (SIGINT) TRÈS SECRET (SIGINT) <input type="checkbox"/>		TOP SECRET (SIGINT) TRÈS SECRET (SIGINT) <input type="checkbox"/>



PART A (continued) / PARTIE A (suite)

8. Will the supplier require access to PROTECTED and/or CLASSIFIED COMSEC information or assets?
Le fournisseur aura-t-il accès à des renseignements ou à des biens COMSEC désignés PROTÉGÉS et/ou CLASSIFIÉS? No / Non Yes / Oui
If Yes, indicate the level of sensitivity:
Dans l'affirmative, indiquer le niveau de sensibilité :
9. Will the supplier require access to extremely sensitive INFOSEC information or assets?
Le fournisseur aura-t-il accès à des renseignements ou à des biens INFOSEC de nature extrêmement délicate? No / Non Yes / Oui
- Short Title(s) of material / Titre(s) abrégé(s) du matériel :
Document Number / Numéro du document :

PART B - PERSONNEL (SUPPLIER) / PARTIE B - PERSONNEL (FOURNISSEUR)

10. a) Personnel security screening level required / Niveau de contrôle de la sécurité du personnel requis
- | | | | |
|---|---|---|--|
| <input type="checkbox"/> RELIABILITY STATUS
COTE DE FIABILITÉ | <input type="checkbox"/> CONFIDENTIAL
CONFIDENTIEL | <input type="checkbox"/> SECRET
SECRET | <input type="checkbox"/> TOP SECRET
TRÈS SECRET |
| <input type="checkbox"/> TOP SECRET-SIGINT
TRÈS SECRET - SIGINT | <input type="checkbox"/> NATO CONFIDENTIAL
NATO CONFIDENTIEL | <input type="checkbox"/> NATO SECRET
NATO SECRET | <input type="checkbox"/> COSMIC TOP SECRET
COSMIC TRÈS SECRET |
| <input checked="" type="checkbox"/> SITE ACCESS
ACCÈS AUX EMPLACEMENTS | | | |
- Special comments:
Commentaires spéciaux : _____
- NOTE: If multiple levels of screening are identified, a Security Classification Guide must be provided.
REMARQUE : Si plusieurs niveaux de contrôle de sécurité sont requis, un guide de classification de la sécurité doit être fourni.

10. b) May unscreened personnel be used for portions of the work?
Du personnel sans autorisation sécuritaire peut-il se voir confier des parties du travail? No / Non Yes / Oui
If Yes, will unscreened personnel be escorted?
Dans l'affirmative, le personnel en question sera-t-il escorté? No / Non Yes / Oui

PART C - SAFEGUARDS (SUPPLIER) / PARTIE C - MESURES DE PROTECTION (FOURNISSEUR)

INFORMATION / ASSETS / RENSEIGNEMENTS / BIENS

11. a) Will the supplier be required to receive and store PROTECTED and/or CLASSIFIED information or assets on its site or premises?
Le fournisseur sera-t-il tenu de recevoir et d'entreposer sur place des renseignements ou des biens PROTÉGÉS et/ou CLASSIFIÉS? No / Non Yes / Oui
11. b) Will the supplier be required to safeguard COMSEC information or assets?
Le fournisseur sera-t-il tenu de protéger des renseignements ou des biens COMSEC? No / Non Yes / Oui

PRODUCTION

11. c) Will the production (manufacture, and/or repair and/or modification) of PROTECTED and/or CLASSIFIED material or equipment occur at the supplier's site or premises?
Les installations du fournisseur serviront-elles à la production (fabrication et/ou réparation et/ou modification) de matériel PROTÉGÉ et/ou CLASSIFIÉ? No / Non Yes / Oui

INFORMATION TECHNOLOGY (IT) MEDIA / SUPPORT RELATIF À LA TECHNOLOGIE DE L'INFORMATION (TI)

11. d) Will the supplier be required to use its IT systems to electronically process, produce or store PROTECTED and/or CLASSIFIED information or data?
Le fournisseur sera-t-il tenu d'utiliser ses propres systèmes informatiques pour traiter, produire ou stocker électroniquement des renseignements ou des données PROTÉGÉS et/ou CLASSIFIÉS? No / Non Yes / Oui
11. e) Will there be an electronic link between the supplier's IT systems and the government department or agency?
Disposera-t-on d'un lien électronique entre le système informatique du fournisseur et celui du ministère ou de l'agence gouvernementale? No / Non Yes / Oui



Contract Number / Numéro du contrat 100021664
Security Classification / Classification de sécurité

PART C - (continued) / PARTIE C - (suite)

For users completing the form **manually** use the summary chart below to indicate the category(ies) and level(s) of safeguarding required at the supplier's site(s) or premises.

Les utilisateurs qui remplissent le formulaire **manuellement** doivent utiliser le tableau récapitulatif ci-dessous pour indiquer, pour chaque catégorie, les niveaux de sauvegarde requis aux installations du fournisseur.

For users completing the form **online** (via the Internet), the summary chart is automatically populated by your responses to previous questions.

Dans le cas des utilisateurs qui remplissent le formulaire **en ligne** (par Internet), les réponses aux questions précédentes sont automatiquement saisies dans le tableau récapitulatif.

SUMMARY CHART / TABLEAU RÉCAPITULATIF

Category / Catégorie	PROTECTED / PROTÉGÉ			CLASSIFIED / CLASSIFIÉ			NATO				COMSEC					
	A	B	C	CONFIDENTIAL / CONFIDENTIEL	SECRET	TOP SECRET / TRÈS SECRET	NATO RESTRICTED / NATO DIFFUSION RESTREINTE	NATO CONFIDENTIAL / NATO CONFIDENTIEL	NATO SECRET	COSMIC TOP SECRET / COSMIC TRÈS SECRET	PROTECTED / PROTÉGÉ			CONFIDENTIAL / CONFIDENTIEL	SECRET	TOP SECRET / TRÈS SECRET
											A	B	C			
Information / Assets / Renseignements / Biens / Production																
IT Media / Support TI																
IT Link / Lien électronique																

12. a) Is the description of the work contained within this SRCL PROTECTED and/or CLASSIFIED? No / Non Yes / Oui
 La description du travail visé par la présente LVERS est-elle de nature PROTÉGÉE et/ou CLASSIFIÉE?

If Yes, classify this form by annotating the top and bottom in the area entitled "Security Classification".
Dans l'affirmative, classifiez le présent formulaire en indiquant le niveau de sécurité dans la case intitulée « Classification de sécurité » au haut et au bas du formulaire.

12. b) Will the documentation attached to this SRCL be PROTECTED and/or CLASSIFIED? No / Non Yes / Oui
 La documentation associée à la présente LVERS sera-t-elle PROTÉGÉE et/ou CLASSIFIÉE?

If Yes, classify this form by annotating the top and bottom in the area entitled "Security Classification" and indicate with attachments (e.g. SECRET with Attachments).
Dans l'affirmative, classifiez le présent formulaire en indiquant le niveau de sécurité dans la case intitulée « Classification de sécurité » au haut et au bas du formulaire et indiquez qu'il y a des pièces jointes (p. ex. SECRET avec des pièces jointes).



Contract Number / Numéro du contrat 100021664
Security Classification / Classification de sécurité

PART D - AUTHORIZATION / PARTIE D - AUTORISATION

13. Organization Project Authority / Chargé de projet de l'organisme			
Name (print) - Nom (en lettres moulées) Felipe Ochoa		Title - Titre Gestionnaire des opérations	Signature Ochoa, Felipe <small>Signature numérique de Ochoa, Felipe Date : 2022.06.27 10:43:26 -04'00'</small>
Telephone No. - N° de téléphone	Facsimile No. - N° de télécopieur	E-mail address - Adresse courriel	Date
14. Organization Security Authority / Responsable de la sécurité de l'organisme			
Name (print) - Nom (en lettres moulées) Laliberte, James		Title - Titre	Signature Digitally signed by Laliberte, James <small>Date: 2022.06.27 11:21:44 -04'00'</small>
Telephone No. - N° de téléphone	Facsimile No. - N° de télécopieur	E-mail address - Adresse courriel	Date
15. Are there additional instructions (e.g. Security Guide, Security Classification Guide) attached? Des instructions supplémentaires (p. ex. Guide de sécurité, Guide de classification de la sécurité) sont-elles jointes?			<input type="checkbox"/> No / <input type="checkbox"/> Yes <input type="checkbox"/> Non / <input type="checkbox"/> Oui
16. Procurement Officer / Agent d'approvisionnement			
Name (print) - Nom (en lettres moulées)		Title - Titre	Signature
Telephone No. - N° de téléphone	Facsimile No. - N° de télécopieur	E-mail address - Adresse courriel	Date
17. Contracting Security Authority / Autorité contractante en matière de sécurité			
Name (print) - Nom (en lettres moulées)		Title - Titre	Signature
Telephone No. - N° de téléphone	Facsimile No. - N° de télécopieur	E-mail address - Adresse courriel	Date