

| | | |
|---|---|--|
| <p>RETURN BIDS TO: RETOURNER LES SOUMISSIONS À:</p> <p>Bid Receiving - Environment and Climate Change Canada / Réception des soumissions – Environnement et changement climatique Canada</p> <p>Procurement Office / Bureau des achats 867 Lakeshore Road / 867, chemin Lakeshore Burlington, ON L7S 1A1</p> <p>Electronic Copy/copie électronique: soumissionsbids@ec.gc.ca</p> <p>BID SOLICITATION DEMANDE DE SOUMISSIONS</p> <p>PROPOSAL TO: ENVIRONMENT AND CLIMATE CHANGE CANADA</p> <p>We offer to perform or provide to Canada the services detailed in the document including any attachments and annexes, in accordance with the terms and conditions set out or referred to in the document, at the price(s) provided.</p> <p>SOUSSION À: ENVIRONNEMENT ET CHANGEMENT CLIMATIQUE CANADA</p> <p>Nous offrons d'effectuer ou de fournir au Canada, aux conditions énoncées ou incluses par référence dans le document incluant toutes pièces jointes et annexes, les services détaillés dans le document, au(x) prix indiqué(s).</p> | <p>Title – Titre Transportation Work for an Automated Radiosonde Launching System at the Inukjuak Upper Air Station</p> | |
| | <p>ECCC Bid Solicitation No. /SAP No. – N° de la demande de soumissions ECCC / N° SAP 5000067250T3</p> | |
| | <p>Date of Bid solicitation (YYYY-MM-DD) – Date de la demande de soumissions (AAAA-MM-JJ) 2022-09-07</p> | |
| | <p>Bid Solicitation Closes (YEAR-MM-DD) - La demande de soumissions prend fin (AAAA-MM-JJ) at – à 2:00 P.M. on – le 2022-09-27</p> | <p>Time Zone – Fuseau horaire Eastern Daylight Time (EDT)</p> |
| | <p>F.O.B – F.A.B See herein</p> | |
| | <p>Address Enquiries to - Adresser toutes questions à Caitlin Andersen – Caitlin.Andersen@ec.gc.ca</p> | |
| | <p>Telephone No. – N° de téléphone 289-348-0283</p> | <p>Fax No. – N° de Fax N/A</p> |
| | <p>Delivery Required (YEAR-MM-DD) – Livraison exigée (AAAA-MM-JJ) See herein</p> | |
| | <p>Destination of Services / Destination des services Inukjuak, Quebec</p> | |
| | <p>Security / Sécurité There is no security requirement associated with this solicitation.</p> | |
| <p>Vendor/Firm Name and Address - Raison sociale et adresse du fournisseur/de l'entrepreneur</p> | | |
| <p>Telephone No. – N° de téléphone</p> | <p>Fax No. – N° de Fax</p> | |
| <p>Name and title of person authorized to sign on behalf of Vendor/Firm: (type or print) / Nom et titre de la personne autorisée à signer au nom du fournisseur/de l'entrepreneur (taper ou écrire en caractères d'imprimerie)</p> | | |
| <p>_____ Signature</p> | <p>_____ Date</p> | |

TABLE OF CONTENTS

| | |
|---|-----------|
| PART 1 - GENERAL INFORMATION..... | 4 |
| 1.1 Introduction..... | 4 |
| 1.2 Summary | 4 |
| 1.3 Debriefings..... | 5 |
| PART 2 – BIDDER INSTRUCTIONS..... | 6 |
| 2.1. Standard Instructions, Clauses and Conditions | 6 |
| 2.2. SACC Manual Clauses – Conditionally Limited | 7 |
| 2.3. Submission of Bids..... | 8 |
| 2.4. Former Public Servant – Competitive Bid..... | 8 |
| 2.5. Enquiries - Bid Solicitation | 9 |
| 2.6. Applicable Laws | 10 |
| 2.7. Bid Challenge and Recourse Mechanisms | 10 |
| PART 3 - BID PREPARATION INSTRUCTIONS..... | 10 |
| 3.1. Bid Preparation Instructions..... | 10 |
| PART 4 - EVALUATION PROCEDURES AND BASIS OF SELECTION..... | 15 |
| 4.1. Evaluation Procedures | 15 |
| 4.2. Technical Evaluation | 15 |
| 4.3. Financial Evaluation..... | 15 |
| 4.4. Basis of Selection | 16 |
| PART 5 - CERTIFICATIONS..... | 18 |
| 5.1. Certifications Required Precedent to Contract Award | 18 |
| 5.2. Additional Certifications Required Precedent to Contract Award | 18 |
| 5.3. Certifications Required with the Bid..... | 19 |
| 5.4. Set-aside for Aboriginal Business | 19 |
| 5.5. Certifications Required Upon Request..... | 20 |
| PART 6 – RESULTING CONTRACT..... | 21 |
| 6.1. Statement of Work..... | 21 |
| 6.2. Standard Clauses and Conditions | 21 |
| 6.3. Security Requirement | 22 |
| 6.4. Term of Contract | 22 |
| 6.5. Authorities..... | 22 |
| 6.6. Proactive Disclosure of Contracts with Former Public Servants..... | 23 |

| | | |
|---------------------------------------|--|-----------|
| 6.7. | Payment..... | 23 |
| 6.8. | Invoicing Instructions..... | 24 |
| 6.9. | Certifications and Additional Information..... | 24 |
| 6.10. | Applicable Laws | 25 |
| 6.11. | Priority of Documents..... | 25 |
| 6.12. | Insurance..... | 25 |
| 6.13. | Dispute Resolution | 26 |
| ANNEX A..... | | 27 |
| | STATEMENT OF WORK | 27 |
| ANNEX B..... | | 31 |
| | BASIS OF PAYMENT | 31 |
| ANNEX C..... | | 33 |
| INDIGENOUS BENEFITS PLAN | | 33 |

List of Attachments:

Attachment A to Part 3, Financial Bid Presentation Sheet

List of Annexes:

| | |
|---------|--------------------------|
| Annex A | Statement of Work |
| Annex B | Basis of Payment |
| Annex C | Indigenous Benefits Plan |

PART 1 - GENERAL INFORMATION

1.1 Introduction

The bid solicitation is divided into six parts plus attachments and annexes, as follows:

Part 1 General Information: provides a general description of the requirement;

Part 2 Bidder Instructions: provides the instructions, clauses and conditions applicable to the bid solicitation;

Part 3 Bid Preparation Instructions: provides bidders with instructions on how to prepare their bid;

Part 4 Evaluation Procedures and Basis of Selection: indicates how the evaluation will be conducted, the evaluation criteria that must be addressed in the bid, and the basis of selection;

Part 5 Certifications and Additional Information: includes the certifications and additional information to be provided; and

Part 6 Resulting Contract Clauses: includes the clauses and conditions that will apply to any resulting contract.

The Attachments include the Financial Bid Presentation Sheet

The Annexes include the Statement of Work, the Basis of Payment, and Indigenous Benefits Plan.

1.2 Summary

1.2.1 Environment and Climate Change Canada has a requirement for a contractor to complete Transportation Work for an Automated Radiosonde Launching System at the Inukjuak Upper Air Station as detailed in the Statement of Work, Annex A to the bid solicitation. The period of the contract is from award to October 31, 2022.

1.2.2 Bidders must provide a list of names, or other related information as needed, pursuant to section 01 Integrity Provisions of Standard Instructions 2004.

1.2.3 For services requirements, bidders in receipt of a pension or a lump sum payment must provide the required information as detailed in article 3 of Part 2 of the bid solicitation.

1.2.4 This procurement is subject to the following Comprehensive Land Claims Agreement(s) (CLCAs): James Bay and Northern Quebec Agreement under Section 28 and Section 29 and Northeastern Quebec Agreement.

1.2.5 This procurement is a conditional set aside under the federal government's Procurement Strategy for Indigenous Business. If no beneficiary of the above mentioned CLCA bids on this requirement, and two or more Indigenous Businesses bid, the requirement will be set aside and awarded to the Indigenous bidder with the lowest evaluated price. If two or more compliant bids from Indigenous businesses are received, only these bids will be eligible to be awarded a contract. If fewer than three bids from indigenous businesses are received, then all compliant bids will be evaluated. Refer to Part 2.2 and Part 4 for more information.

Further to Article 800 of the Canadian Free Trade Agreement (CFTA), CFTA does not apply to this procurement.

1.3 Debriefings

Bidders may request a debriefing on the results of the bid solicitation process. Bidders should make the request to the Contracting Authority within 15 working days of receipt of the results of the bid solicitation process. The debriefing may be in writing, by telephone or in person.

PART 2 – BIDDER INSTRUCTIONS

2.1. Standard Instructions, Clauses and Conditions

All instructions, clauses and conditions identified in the bid solicitation by number, date and title are set out in the PSPC/PWGSC *Standard Acquisition Clauses and Conditions Manual* (<https://buyandsell.gc.ca/policy-and-guidelines/standard-acquisition-clauses-and-conditions-manual>) issued by Public Works and Government Services Canada.

Bidders who submit a bid agree to be bound by the instructions, clauses and conditions of the bid solicitation and accept the clauses and conditions of the resulting contract.

The 2003 (2022-03-29) Standard Instructions - Goods or Services - Competitive Requirements, are incorporated by reference into and form part of the bid solicitation.

The standard instructions 2003 are modified as follows:

Under “Text” at 02:

Delete: “Procurement Business Number”

Insert: “Deleted”

At Section 02 Procurement Business Number

Delete: In its entirety

Insert: “Deleted”

At Section 05 Submission of Bids, Subsection 05 (2d):

Delete: In its entirety

Insert: “send its bid only to Environment and Climate Change Canada as specified on page 1 of the bid solicitation or to the address specified in the bid solicitation;”

At Section 06 Late Bids:

Delete: “PWGSC”

Insert: “Environment and Climate Change Canada”

At Section 07 Delayed Bids:

Delete: “PWGSC”

Insert: “Environment and Climate Change Canada”

At Section 08 Transmission by Facsimile, Subsection 08 (1):

Delete: In its entirety

At Section 12 Rejection of Bid, Subsection 12 (1) a. and b.:

Delete: In their entirety

Insert: “Deleted”

At Section 17 Joint Venture, Subsection 17 (1) b.:

Delete: “the Procurement Business Number of each member of the joint venture,”

Insert: “Deleted”

At Section 20 Further Information, Subsection 20 (2):

Delete: In its entirety

Insert: “Deleted”

At Section 05 Submission of Bids, Subsection 05 (4):

Delete: “sixty (60) days”

Insert: “one hundred and twenty (120) days”

2.2. SACC Manual Clauses – Conditionally Limited

This is a conditionally limited tender. It will first be set-aside for Comprehensive Land Claims Agreement (CLCA) beneficiaries as per clause W0005T outlined below. If bids from CLCA beneficiaries are found to be non-compliant or non-responsive or are withdrawn, then this solicitation will be set-aside under the Government of Canada’s Procurement Strategy for Indigenous Business (PSIB). If two or more bids have been received from Indigenous businesses who are certified under the PSIB criteria and who may be listed in Indigenous Services Canada's Indigenous Business Directory (<https://www.sac-isc.gc.ca/eng/1100100033057/1610797769658>) or the Inuit Firm Registry (<https://inuitfirm.tunnngavik.com/search-the-registry/>), these bids will be considered for evaluation. If bids from two or more Indigenous businesses are compliant with the terms of the Request for Proposal, the contracting authority will limit the competition to those Indigenous businesses and will not consider bids from any non-Indigenous businesses that may have been submitted. Please see clauses A3000T below and A3000C and A3001T in section 5.4 for more information. If the bids from Indigenous businesses are found to be non-compliant or non-responsive or are withdrawn, such that fewer than two compliant bids from Indigenous businesses remain, all compliant bids received in response to this solicitation will be evaluated.

W0005T (2022-05-12), Set-aside for Comprehensive Land Claims Agreement(s) beneficiaries

This procurement is reserved for beneficiaries of the following Comprehensive Land Claims Agreement(s) (CLCAs) : James Bay and Northern Quebec Agreement under Section 28 and Section 29 and Northeastern Quebec Agreement.

A3000T (2022-05-12), Set-aside for Indigenous Business

1. This procurement is set aside under the federal government Procurement Strategy for Indigenous Business, For more information on Indigenous business requirements of the Set-aside Program for Indigenous Business, see [Annex 9.4](#), Supply Manual.
2. The Bidder:
 - i. certifies that it meets, and will continue to meet throughout the duration of any resulting contract, the requirements described in the above-mentioned annex;
 - ii. agrees that any subcontractor it engages under any resulting contract must satisfy the requirements described in the above-mentioned annex; and
 - iii. agrees to provide to Canada, immediately upon request, evidence supporting any subcontractor's compliance with the requirements described in the above-mentioned annex.
3. The Bidder must check the applicable box below:
 - i. The Bidder is an Indigenous business that is a sole proprietorship, band, limited company, co-operative, partnership or not-for-profit organization.
OR
 - ii. The Bidder is either a joint venture consisting of two or more Indigenous businesses or a joint venture between an Indigenous business and a non-Indigenous business.
4. The Bidder must, upon request by Canada, provide all information and evidence supporting this certification. The Bidder must ensure that this evidence will be available for audit during normal business hours by a representative of Canada, who may make copies and take extracts from the evidence. The Bidder must provide all reasonably required facilities for any audits.

5. By submitting a bid, the Bidder certifies that the information submitted by the Bidder in response to the above requirements is accurate and complete.

A7035T (2007-05-25), List of Proposed Subcontractors

If the bid includes the use of subcontractors, the Bidder agrees, upon request from the Contracting Authority, to provide a list of all subcontractors including a description of the things to be purchased, a description of the work to be performed and the location of the performance of that work. The list should not include the purchase of off-the-shelf items, software and such standard articles and materials as are ordinarily produced by manufacturers in the normal course of business, or the provision of such incidental services as might ordinarily be subcontracted in performing the Work.

2.3. Submission of Bids

Bids must be submitted to Environment and Climate Change Canada at the address and by the date, time and place indicated on page 1 of the bid solicitation.

2.4. Former Public Servant – Competitive Bid

Contracts awarded to former public servants (FPS) in receipt of a pension or of a lump sum payment must bear the closest public scrutiny, and reflect fairness in the spending of public funds. In order to comply with Treasury Board policies and directives on contracts awarded to FPS, bidders must provide the information required below before contract award. If the answer to the questions and, as applicable the information required have not been received by the time the evaluation of bids is completed, Canada will inform the Bidder of a time frame within which to provide the information. Failure to comply with Canada's request and meet the requirement within the prescribed time frame will render the bid non-responsive.

Definitions

For the purposes of this clause, "former public servant" is any former member of a department as defined in the [Financial Administration Act](#) R.S., 1985, c. F-11, a former member of the Canadian Armed Forces or a former member of the Royal Canadian Mounted Police. A former public servant may be:

- a. an individual;
- b. an individual who has incorporated;
- c. a partnership made of former public servants; or
- d. a sole proprietorship or entity where the affected individual has a controlling or major interest in the entity.

"lump sum payment period" means the period measured in weeks of salary, for which payment has been made to facilitate the transition to retirement or to other employment as a result of the implementation of various programs to reduce the size of the Public Service. The lump sum payment period does not include the period of severance pay, which is measured in a like manner.

"pension" means a pension or annual allowance paid under the [Public Service Superannuation Act](#) (PSSA), R.S., 1985, c.P-36, and any increases paid pursuant to the [Supplementary Retirement Benefits Act](#), R.S., 1985, c.S-24 as it affects the PSSA. It does not include pensions payable pursuant to the [Canadian Forces Superannuation Act](#), R.S., 1985, c.C-17, the [Defence Services Pension](#)

[Continuation Act](#) 1970, c.D-3, the [Royal Canadian Mounted Police Pension Continuation Act](#) , , 1970, c.R-10, and the [Royal Canadian Mounted Police Superannuation Act](#), R.S., 1985, c.R-11, the [Members of Parliament Retiring Allowances Act](#), R.S., 1985, c.M-5, and that portion of pension payable to the [Canada Pension Plan Act](#), R.S., 1985, c.C-8.

Former Public Servant in Receipt of a Pension

As per the above definitions, is the Bidder a FPS in receipt of a pension? **Yes** () **No** ()

If so, the Bidder must provide the following information, for all FPS in receipt of a pension, as applicable:

- a. name of former public servant;
- b. date of termination of employment or retirement from the Public Service.

By providing this information, Bidders agree that the successful Bidder's status, with respect to being a former public servant in receipt of a pension, will be reported on departmental websites as part of the published proactive disclosure reports in accordance with [Contracting Policy Notice: 2019-01](#) and the [Guidelines on the Proactive Disclosure of Contracts](#).

Work Force Adjustment Directive

Is the Bidder a FPS who received a lump sum payment pursuant to the terms of the Work Force Adjustment Directive? **Yes** () **No** ()

If so, the Bidder must provide the following information:

- a. name of former public servant;
- b. conditions of the lump sum payment incentive;
- c. date of termination of employment;
- d. amount of lump sum payment;
- e. rate of pay on which lump sum payment is based;
- f. period of lump sum payment including start date, end date and number of weeks;
- g. number and amount (professional fees) of other contracts subject to the restrictions of a work force adjustment program.

2.5. Enquiries - Bid Solicitation

All enquiries must be submitted in writing to the Contracting Authority no later than 7 calendar days before the bid closing date. Enquiries received after that time may not be answered.

Bidders should reference as accurately as possible the numbered item of the bid solicitation to which the enquiry relates. Care should be taken by bidders to explain each question in sufficient detail in order to enable Canada to provide an accurate answer. Technical enquiries that are of a proprietary nature must be clearly marked "proprietary" at each relevant item. Items identified as "proprietary" will

be treated as such except where Canada determines that the enquiry is not of a proprietary nature. Canada may edit the question(s) or may request that the Bidder do so, so that the proprietary nature of the question(s) is eliminated and the enquiry can be answered to all bidders. Enquiries not submitted in a form that can be distributed to all bidders may not be answered by Canada.

2.6. Applicable Laws

Any resulting contract must be interpreted and governed, and the relations between the parties determined, by the laws in force in Québec.

Bidders may, at their discretion, substitute the applicable laws of a Canadian province or territory of their choice without affecting the validity of their bid, by deleting the name of the Canadian province or territory specified and inserting the name of the Canadian province or territory of their choice. If no change is made, it acknowledges that the applicable laws specified are acceptable to the bidders.

2.7. Bid Challenge and Recourse Mechanisms

Bid Challenge and Recourse Mechanisms

- (a) Several mechanisms are available to potential suppliers to challenge aspects of the procurement process up to and including contract award.
- (b) Canada encourages suppliers to first bring their concerns to the attention of the Contracting Authority. Canada's [Buy and Sell](#) website, under the heading "[Bid Challenge and Recourse Mechanisms](#)" contains information on potential complaint bodies such as:
 - Office of the Procurement Ombudsman (OPO)
 - Canadian International Trade Tribunal (CITT)
- (c) Suppliers should note that there are **strict deadlines** for filing complaints, and the time periods vary depending on the complaint body in question. Suppliers should therefore act quickly when they want to challenge any aspect of the procurement process.

PART 3 - BID PREPARATION INSTRUCTIONS

3.1. Bid Preparation Instructions

Canada requests that bidders provide their bid in separately bound sections as follows:

Section I: Technical Bid – one (1) electronic copy in PDF format or one (1) hard copy.

Section II: Indigenous Benefits Plan – one (1) electronic copy in PDF format or one (1) hard copy.

Section III: Financial Bid – one (1) electronic copy in PDF format or one (1) hard copy.

Section IV: Certifications – one (1) electronic copy in PDF format or one (1) hard copy.

Prices must appear in the financial bid and, if applicable, within the Indigenous benefits plan only. No prices must be indicated in any other section of the bid.

Note for electronic submission of bids:

In order to be considered, bids must be received by the date and time indicated on the cover page to herein as the "Closing Date." Bids received after the Closing Date will be considered non-responsive and will not be considered for contract award. Bids submitted by email must be submitted ONLY to the following email address:

Email Address: soumissionsbids@ec.gc.ca

Attention: Caitlin Andersen

Solicitation Number: 5000067250

Bidders should ensure that their name, address, Closing Date of the solicitation and Solicitation Number are clearly indicated in the body of their email. Bids and supporting information may be submitted in either English or French.

The total size of the email, including all attachments, must be less than 15 megabytes (MB). It is each Bidder's responsibility to ensure that the total size of the email does not exceed this limit.

Bids sent by fax will not be accepted.

It is important to note that emails systems can experience systematic delays and, at times, large attachments may cause systems to hold or delay transmission of emails. It is solely the Bidder's responsibility to ensure that the Contracting Authority receives a bid on time, in the mailbox that has been identified for bid receipt purposes. Date stamps for this form of transmission are not acceptable.

Section I: Technical Bid

In their technical bid, bidders should demonstrate their understanding of the requirements contained in the bid solicitation and explain how they will meet these requirements. Bidders should demonstrate their capability and describe their approach in a thorough, concise and clear manner for carrying out the work.

The technical bid should address clearly and in sufficient depth the points that are subject to the evaluation criteria against which the bid will be evaluated. Simply repeating the statement contained in the bid solicitation is not sufficient. In order to facilitate the evaluation of the bid, Canada requests that bidders address and present topics in the order of the evaluation criteria under the same headings. To avoid duplication, bidders may refer to different sections of their bids by identifying the specific paragraph and page number where the subject topic has already been addressed.

Part 4, Evaluation Procedures, contains additional instructions that bidders should consider when preparing their technical bid.

Section II: Indigenous Benefits Plan

If an Indigenous Benefits Plan (IBP) is submitted, it must be submitted in accordance with Annex "C". This is an optional document. It is not required for JBNQA and NEQA CLCA beneficiaries but optional for all other bidders.

Section III: Financial Bid

Bidders must submit their financial bid in accordance with the Basis of Payment in Annex "B" and the Attachment A to Part 3 – Financial Bid Presentation Sheet. The total amount of Applicable Taxes must be shown separately.

3.1.4 Price Breakdown

In their financial bid, the bidders are requested to provide a detailed breakdown of the price for the following elements for each task of the Work, as applicable:

- (a) Professional fees: For each individual and (or) labour category to be assigned to the Work, the bidders should indicate: i) the firm hourly rate or the firm daily rate, inclusive of overhead and profit; and ii) the estimated number of hours or days, as applicable. The bidders should indicate the number of hours in one working day.

The professional fees must include the total estimated cost of all travel and living expenses that may need to be incurred for:

- (i) Work described in Part 6, Resulting Contract of the bid solicitation required to be performed within Inukjuak, Quebec.
- (ii) travel between the successful bidder's place of business and Inukjuak, Quebec; and
- (iii) the relocation of resources

to satisfy the terms of any resulting contract. These expenses cannot be charged directly and separately from the professional fees to any contract that may result from the bid solicitation.

- (b) Equipment (if applicable): The bidders should specify each item required to complete the Work and provide the pricing basis of each one, Canadian customs duty and excise taxes included, as applicable.
- (c) Materials and Supplies (if applicable): The bidders should identify each category of materials and supplies required to complete the Work and provide the pricing basis. The Bidder should indicate, on a per category basis, whether the items are likely to be consumed during the performance of any resulting contract.
- (d) Travel and Living Expenses (if applicable): The bidders should indicate the number of trips and the number of days for each trip, the cost, destination and purpose of each journey, together with the basis of these costs without exceeding the meal, private vehicle and incidental expenses provided in Appendices B, C and D of the *National Joint Council Travel Directive* and with the other provisions of the directive referring to "travellers", rather than those referring to "employees".
- (e) Subcontracts (if applicable): The bidders should identify all of the proposed subcontractors and provide in their financial bid for each one a price breakdown.
- (f) Other Direct Charges (if applicable): The bidders should identify all of the categories of other direct charges anticipated, such as long distance communications and rentals, providing the pricing basis for each and explaining the relevance to the work described in Part 6 of the bid solicitation.
- (g) Applicable Taxes: The bidders should indicate the Applicable Taxes separately.

3.1.5 Bidders should include the following information in their financial bid:

- (a) Their legal name; and
- (b) The name of the contact person (including this person's mailing address, phone and facsimile numbers and email address) authorized by the Bidder to enter into communications with Canada with regards to their bid; and any contract that may result from their bid.

3.1.6 Other clauses

G1005C (2016-01-28), Insurance - No Specific Requirement

The Contractor is responsible for deciding if insurance coverage is necessary to fulfill its obligation under the Contract and to ensure compliance with any applicable law. Any insurance acquired or maintained by the Contractor is at its own expense and for its own benefit and protection. It does not release the Contractor from or reduce its liability under the Contract

Section IV: Certifications

Bidders must submit the certifications required under Part 5.

PART 4 - EVALUATION PROCEDURES AND BASIS OF SELECTION

4.1. Evaluation Procedures

- (a) Bids will be assessed in accordance with the entire requirement of the bid solicitation including the technical, financial and any additional evaluation criteria.
- (b) An evaluation team composed of representatives of Canada will evaluate the bids.
- (c) The evaluation team will determine if there are bids from CLCA beneficiaries as described in Section 2.2. If a compliant bid from a CLCA beneficiary is not received, the evaluation team will then determine if there are bids from registered Indigenous businesses as described in Section 2.2. If two (2) or more compliant bids from registered Indigenous businesses are received, only those bids will be eligible to be awarded a contract. Otherwise, all bids received will be evaluated.

If at any point in the evaluation process it is found, whether by determination of invalidity of certifications, determination that bids are non-responsive or withdrawal of bids by Bidders, that there are no longer two (2) or more responsive bids with a valid certification, then all responsive bids will be eligible to be awarded a contract. Canada may conduct the validation of certifications at any time in the evaluation process including doing so concurrently with other steps.

4.2. Technical Evaluation

The technical portion of this bid will provide the required information to allow the evaluation team to make a determination on whether or not the bidder meets any CLCA beneficiary or Indigenous Business Criteria outlined in Section 4.1.c and Section 2.2. Please include information in this section that will allow you to be considered against these requirements.

4.2.1. Indigenous Benefits Plan (IBP)

The Indigenous Benefits Plan will be considered if no bidder is found that meets the CLCA beneficiary criteria or if there are less than two (2) or more compliant bids from registered Indigenous businesses.

| Criteria | Total Points Available | Total Score |
|--|------------------------|-------------|
| Indigenous employment | 10 | /10 |
| Indigenous training and skills development | 10 | /10 |
| Indigenous ownership/sub-contractors/suppliers | 10 | /10 |
| Location in the Comprehensive Land Claim Agreement (CLCA) Area | 5 | /5 |
| Grand Total | | /35 |

There is no pass mark for this section. The Indigenous Benefits Plan (IBP) Evaluation Criteria are included in Annex "C".

4.3. Financial Evaluation

4.3.1 Evaluation of Price

The price of the bid will be evaluated in Canadian dollars, the Applicable Taxes excluded, Canadian customs and excise taxes included.

For evaluation purposes only, the price of the bid will be determined as follows:

4.3.1.2. For bid evaluation and contractor(s) selection purposes only, the evaluated price of a bid will be determined in accordance with the Financial Bid Presentation Sheet detailed in Attachment A to Part 3.

4.4 Basis of Selection

1. To be declared responsive, a bid must:
 - a. comply with all the requirements of the bid solicitation; and
 - b. meet all mandatory criteria;
2. Bids not meeting (a) or (b) will be declared non-responsive.

4.4.1 CLCA Beneficiaries - Lowest Price

In the instance where more than one (1) bid is received from a JBNQA and NEQA CLCA beneficiary, the selection will be based on the lowest price provider amongst these responsive bidders.

4.4.2 Indigenous Businesses - Lowest Price

In the instance where no bids are received from a JBNQA and NEQA CLCA beneficiary, but two (2) or more bids are received from Indigenous Businesses, the selection will be based on the lowest price provider amongst these responsive bidders.

4.4.3 Other Bidders - Highest Combined Rating of Indigenous Benefits Plan (IBP) Commitment, and Price

In the instance where no bids are received from a JBNQA and NEQA CLCA beneficiary, and less than two (2) bids are received from Indigenous Businesses, the selection will be based on a combined rating of Indigenous Benefits Plan (IBP) and Price.

1. The selection will be based on the highest responsive combined rating of IBP quality, and price. The ratio will be 35% for the IBP quality, and 65% for the price.
2. To establish the pricing score, the overall pricing score for each responsive bid will be determined as follows: total number of points obtained / maximum number of points available multiplied by the ratio of 65%.
3. To establish the IBP quality score, the overall IBP quality score for each responsive bid will be determined as follows: The total number of points obtained / maximum number of points available multiplied by the ratio of 35%.
4. For each responsive bid, the IBP quality score, and the pricing score will be added to determine its combined rating.
5. The responsive bid with the lowest evaluated price will not necessarily be accepted. The responsive bid with the highest combined rating of IBP quality, and price will be recommended for award of a contract. In the case of a tie, the bid with the lower price will be selected.

The table below illustrates an example where all three bids are responsive and the selection of the Contractor is determined by a 35/65 ratio of IBP quality, and price, respectively. The lowest evaluated price is \$450,000

Basis of Selection - Highest Combined Rating of IBP Commitment (35%), and Price (65%)

| | | Bidder 1 | Bidder 2 | Bidder 3 |
|--------------------------|-----------------------|------------------------------------|-------------------------------------|------------------------------------|
| Bid Evaluated Price | | \$500,000.00 | \$550,000.00 | \$450,000.00 |
| Indigenous Benefits Plan | | 15/35 | 35/35 | 0/35 |
| Calculations | Pricing Score | $450,000/500,000 \times 65 = 58.5$ | $450,000/550,000 \times 65 = 53.18$ | $450,000/450,000 \times 25 = 65.0$ |
| | IBP Commitment | $15/35 \times 35 = 15$ | $35/35 \times 35 = 35$ | $0/35 \times 35 = 0$ |
| Combined Rating | | 73.5 | 88.18 | 65 |
| Overall Rating | | 2nd | 1st | 3rd |

In the case of a tie, the proponent submitting the lower bid evaluation price for the services will be selected.

PART 5 - CERTIFICATIONS

Bidders must provide the required certifications and associated information to be awarded a contract.

The certifications provided by bidders to Canada are subject to verification by Canada at all times. Canada will declare a bid non-responsive, or will declare a contractor in default in carrying out any of its obligations under the Contract, if any certification made by the Bidder is found to be untrue, whether made knowingly or unknowingly, during the bid evaluation period or during the contract period.

The Contracting Authority will have the right to ask for additional information to verify the Bidder's certifications. Failure to comply and to cooperate with any request or requirement imposed by the Contracting Authority may render the bid non-responsive or constitute a default under the Contract.

5.1. Certifications Required Precedent to Contract Award

5.1.1 Integrity Provisions - Associated Information

By submitting a bid, the Bidder certifies that the Bidder and its Affiliates are in compliance with the provisions as stated in Section 01 Integrity Provisions - Bid of Standard Instructions 2004. The associated information required within the Integrity Provisions will assist Canada in confirming that the certifications are true.

5.1.2. Federal Contractors Program for Employment Equity - Bid Certification

By submitting a bid, the Bidder certifies that the Bidder, and any of the Bidder's members if the Bidder is a Joint Venture, is not named on the Federal Contractors Program (FCP) for employment equity "FCP Limited Eligibility to Bid" list available at the bottom of the page of the [Employment and Social Development Canada \(ESDC\) - Labour's](https://www.canada.ca/en/employment-social-development/programs/employment-equity/federal-contractor-program.html#) website (<https://www.canada.ca/en/employment-social-development/programs/employment-equity/federal-contractor-program.html#>).

Canada will have the right to declare a bid non-responsive if the Bidder, or any member of the Bidder if the Bidder is a Joint Venture, appears on the "FCP Limited Eligibility to Bid" list at the time of contract award.

5.2. Additional Certifications Required Precedent to Contract Award

The certifications listed below should be completed and submitted with the bid but may be submitted afterwards. If any of these required certifications is not completed and submitted as requested, the Contracting Authority will inform the Bidder of a time frame within which to provide the information. Failure to comply with the request of the Contracting Authority and to provide the certifications within the time frame provided will render the bid non-responsive.

5.2.1. Status and Availability of Resources

The Bidder certifies that, should it be awarded a contract as a result of the bid solicitation, every individual proposed in its bid will be available to perform the Work as required by Canada's representatives and at the time specified in the bid solicitation or agreed to with Canada's representatives. If for reasons beyond its control, the Bidder is unable to provide the services of an individual named in its bid, the Bidder may propose a substitute with similar qualifications and experience. The Bidder must advise the Contracting Authority of the reason for the substitution and provide the name, qualifications and experience of the proposed replacement. For the purposes of this clause, only the following reasons will be considered as beyond the control of the Bidder: death,

sickness, maternity and parental leave, retirement, resignation, dismissal for cause or termination of an agreement for default.

If the Bidder has proposed any individual who is not an employee of the Bidder, the Bidder certifies that it has the permission from that individual to propose his/her services in relation to the Work to be performed and to submit his/her résumé to Canada. The Bidder must, upon request from the Contracting Authority, provide a written confirmation, signed by the individual, of the permission given to the Bidder and of his/her availability. Failure to comply with the request may result in the bid being declared non-responsive.

5.3. Certifications Required with the Bid

Bidders must submit the following duly completed certifications as part of their bid.

1. Owner Certification as per A30001T noted below.

5.4. Set-aside for Aboriginal Business

A3000C (2022-05-12), Indigenous Business Certification

1. The Contractor warrants that its certification of compliance is accurate and complete and in accordance with the "Requirements for the Set-aside Program for Indigenous Business" detailed in [Annex 9.4](#) of the *Supply Manual*.
2. The Contractor must keep proper records and documentation relating to the accuracy of the certification provided to Canada. The Contractor must obtain the written consent of the Contracting Authority before disposing of any such records or documentation before the expiration of six years after final payment under the Contract, or until settlement of all outstanding claims and disputes, under the Contract, whichever is later. All such records and documentation must at all times during the retention period be open to audit by the representatives of Canada, who may make copies and take extracts. The Contractor must provide all reasonably required facilities for any audits.
3. Nothing in this clause must be interpreted as limiting the rights and remedies which Canada may otherwise have pursuant to the Contract.

A3001T (2022-05-12), Owner Certification - Set-aside for Indigenous Business

If requested by the Contracting Authority, the Bidder must provide the following certification for each owner who is Indigenous:

1. I am an owner of _____ (*insert name of business*), and an Indigenous person, as defined in [Annex 9.4](#) of the *Supply Manual* entitled "Requirements for the Set-aside Program for Indigenous Business".
2. I certify that the above statement is true and consent to its verification upon request by Indigenous Services Canada.

Printed name of owner

Signature of owner

Date

5.5 Certifications Required Upon Request

It is the responsibility of the Contractor to ensure they are in good standing with all Federal, Provincial and Municipal regulatory bodies and possess all required licences and certificates to complete the work under the Contract for the duration of the Contract. The Contractor must produce proof of any of these documents upon a request made by the Contracting or Technical Authorities.

PART 6 – RESULTING CONTRACT

The following clauses and conditions apply to and form part of any contract resulting from the bid solicitation.

Title: *(insert only at contract award)*

6.1. Statement of Work

The Contractor must perform the Work in accordance with the Statement of Work at Annex A.

6.2. Standard Clauses and Conditions

All clauses and conditions identified in the Contract by number, date and title are set out in the PSPC/PWGSC *Standard Acquisition Clauses and Conditions Manual* (<https://buyandsell.gc.ca/policy-and-guidelines/standard-acquisition-clauses-and-conditions-manual>) issued by Public Works and Government Services Canada.

6.2.1 General Conditions

The 2003 (2022-03-29) Standard Instructions - Goods or Services - Competitive Requirements, are incorporated by reference into and form part of the bid solicitation.

The standard instructions 2003 are modified as follows:

Under “Text” at 02:

Delete: “Procurement Business Number”

Insert: “Deleted”

At Section 02 Procurement Business Number

Delete: In its entirety

Insert: “Deleted”

At Section 05 Submission of Bids, Subsection 05 (2d):

Delete: In its entirety

Insert: “send its bid only to Environment and Climate Change Canada as specified on page 1 of the bid solicitation or to the address specified in the bid solicitation;”

At Section 06 Late Bids:

Delete: “PWGSC”

Insert: “Environment and Climate Change Canada”

At Section 07 Delayed Bids:

Delete: “PWGSC”

Insert: “Environment and Climate Change Canada”

At Section 08 Transmission by Facsimile, Subsection 08 (1):

Delete: In its entirety

At Section 12 Rejection of Bid, Subsection 12 (1) a. and b.:

Delete: In their entirety

Insert: “Deleted”

At Section 17 Joint Venture, Subsection 17 (1) b.:

Delete: “the Procurement Business Number of each member of the joint venture,”

Insert: “Deleted”

At Section 20 Further Information, Subsection 20 (2):

Delete: In its entirety

Insert: “Deleted”

At Section 05 Submission of Bids, Subsection 05 (4):

Delete: “sixty (60) days”

Insert: “one hundred and twenty (120) days”

6.3. Security Requirement

6.3.1 There is no security requirement applicable to this Contract.

6.4. Term of Contract

6.4.1 Period of the Contract

The period of the Contract is from date of Contract to October 31, 2022 inclusive.

6.4.2 Comprehensive Land Claims Agreements (CLCAs)

The Contract is subject to the following Comprehensive Land Claims Agreement(s):

- James Bay and Northern Quebec Agreement (JBNQA)
- Northeastern Quebec Agreement (NEQA)

6.5. Authorities

6.5.1 Contracting Authority

The Contracting Authority for the Contract is:

Name: Caitlin Andersen

Title: Senior Procurement Officer, Strategic Procurement and Governance

Environment and Climate Change Canada

Procurement and Contracting Division

Telephone: 289-348-0283

E-mail address: Caitlin.Andersen@ec.gc.ca

The Contracting Authority is responsible for the management of the Contract and any changes to the Contract must be authorized in writing by the Contracting Authority. The Contractor must not perform work in excess of or outside the scope of the Contract based on verbal or written requests or instructions from anybody other than the Contracting Authority.

6.5.2 Technical Authority

The Technical Authority for the Contract is:

Name: _____ (*insert at contract award*)

Title: _____

Environment and Climate Change Canada

Address: _____

Telephone: ____-____-_____

Facsimile: ____-____-_____

E-mail address: _____

The Technical Authority named above is the representative of the department or agency for whom the Work is being carried out under the Contract and is responsible for all matters concerning the technical content of the Work under the Contract. Technical matters may be discussed with the Technical Authority, however the Technical Authority has no authority to authorize changes to the scope of the Work. Changes to the scope of the Work can only be made through a contract amendment issued by the Contracting Authority.

6.5.4 Contractor's Representative

Name: _____ (*insert at contract award*)

Title: _____

Organization: _____

Address: _____

Telephone: ____-____-_____

Facsimile: ____-____-_____

E-mail address: _____

6.6. Proactive Disclosure of Contracts with Former Public Servants

By providing information on its status, with respect to being a former public servant in receipt of a *Public Service Superannuation Act* (PSSA) pension, the Contractor has agreed that this information will be reported on departmental websites as part of the published proactive disclosure reports, in accordance with [Contracting Policy Notice: 2019-01](#) of the Treasury Board Secretariat of Canada.

6.7. Payment

6.7.1 Basis of Payment

The Contractor will be reimbursed for the costs reasonably and properly incurred in the performance of the Work, as determined in accordance with the Basis of Payment in Annex B, to a limitation of expenditure of \$_____ (*insert the amount at contract award*). Customs duties are included, and Applicable Taxes are extra.

6.7.2 Limitation of Expenditure

- (a) Canada's total liability to the Contractor under the Contract must not exceed \$ _____. Customs duties are included and the Applicable Taxes are extra.
- (b) No increase in the total liability of Canada or in the price of the Work resulting from any design changes, modifications or interpretations of the Work, will be authorized or paid to the Contractor unless these design changes, modifications or interpretations have been approved, in writing, by the Contracting Authority before their incorporation into the Work. The Contractor must not perform any work or provide any service that would result in Canada's total liability

being exceeded before obtaining the written approval of the Contracting Authority. The Contractor must notify the Contracting Authority in writing as to the adequacy of this sum:

- (i) when it is 75 percent committed, or
 - (ii) four (4) months before the contract expiry date, or
 - (iii) as soon as the Contractor considers that the contract funds provided are inadequate for the completion of the Work, whichever comes first.
- (c) If the notification is for inadequate contract funds, the Contractor must provide to the Contracting Authority a written estimate for the additional funds required. Provision of such information by the Contractor does not increase Canada's liability.

6.8. Invoicing Instructions

6.8.1 Single Payment

6.8.1.1 Canada will pay the Contractor upon completion and delivery of the Work in accordance with the payment provisions of the Contract if:

- (a) an accurate and complete invoice and any other documents required by the Contract have been submitted in accordance with the invoicing instructions provided in the Contract;
- (b) all such documents have been verified by Canada;
- (c) the Work delivered has been accepted by Canada.

6.8.2 SACC Manual Clauses

A9117C (2007-11-30) T1204 - Direct Request by Customer Department

1. Pursuant to paragraph 221 (1)(d) of the *Income Tax Act*, R.S. 1985, c. 1 (5th Supp.), payments made by departments and agencies to contractors under applicable services contracts (including contracts involving a mix of goods and services) must be reported on a T1204 Government Service Contract Payments slip.
2. To enable departments and agencies to comply with this requirement, the Contractor must provide Canada, upon request, its business number or Social Insurance Number, as applicable. (These requests may take the form of a general call-letter to contractors, in writing or by telephone).

6.9. Certifications and Additional Information

6.9.1 Compliance

Unless specified otherwise, the continuous compliance with the certifications provided by the Contractor in its bid or precedent to contract award, and the ongoing cooperation in providing additional information are conditions of the Contract and failure to comply will constitute the Contractor in default. Certifications are subject to verification by Canada during the entire period of the Contract.

6.9.2 SACC Manual Clauses

6.9.2.1 Set-aside for Aboriginal Business

A3001T (2022-05-12), Owner Certification - Set-aside for Indigenous Business

If requested by the Contracting Authority, the Bidder must provide the following certification for each owner who is Indigenous:

1. I am an owner of _____ (*insert name of business*), and an Indigenous person, as defined in [Annex 9.4](#) of the *Supply Manual* entitled "Requirements for the Set-aside Program for Indigenous Business".
2. I certify that the above statement is true and consent to its verification upon request by Indigenous Services Canada.

Printed name of owner

Signature of owner

Date

6.10. Applicable Laws

The Contract must be interpreted and governed, and the relations between the parties determined, by the laws in force in _____.[\[to be inserted by bidder\]](#)

6.11. Priority of Documents

If there is a discrepancy between the wording of any documents that appear on the list, the wording of the document that first appears on the list has priority over the wording of any document that subsequently appears on the list.

- (a) the Articles of Agreement;
- (b) the general conditions 2003 (2022-03-29) Standard Instructions - Goods or Services - Competitive Requirements;
- (c) Annex A, Statement of Work;
- (d) Annex B, Basis of Payment;
- (e) Annex C, Indigenous Benefits Plan;
- (f) the Contractor's bid dated _____, (*insert date of bid*) (*If the bid was clarified or amended, insert at the time of contract award.*"), as clarified on _____ " **or** ", as amended on _____ " *and insert date(s) of clarification(s) or amendment(s)*).

6.12. Insurance

SACC Manual clause G1005C (2016-01-28), Insurance – No Specific Requirement

6.13. Dispute Resolution

- (a) The parties agree to maintain open and honest communication about the Work throughout and after the performance of the contract.
- (b) The parties agree to consult and co-operate with each other in the furtherance of the contract and promptly notify the other party or parties and attempt to resolve problems or differences that may arise.
- (c) If the parties cannot resolve a dispute through consultation and cooperation, the parties agree to consult a neutral third party offering alternative dispute resolution services to attempt to address the dispute.
- (d) Options of alternative dispute resolution services can be found on Canada's Buy and Sell website under the heading "[Dispute Resolution](#)".

ANNEX A STATEMENT OF WORK

1.0 TITLE:

Transportation Work required to prepare for the installation of an Automated Radiosonde Launching System (ARLS) and an Automated Weather Station (AWS) at the Inukjuak Upper Air Station in Inukjuak Quebec.

2.0 BACKGROUND:

Environment and Climate Change Canada's (ECCC) Meteorological Services of Canada (MSC) is preparing to install an ARLS and an AWS used to release atmospheric monitoring balloons at the Inukjuak Upper Air Station in Inukjuak Quebec. These automated systems will assist the department in obtaining more accurate and timely data from this weather station. In order to complete this work, ECCC requires assistance to complete transportation work to move materials and equipment from the Inukjuak sealift docks to the Inukjuak Upper Air Station.

3.0 SCOPE

MSC requires acceptance, offloading, and transportation of an ARLS (20'x 8' ISO shipping container) and precast foundation blocks from the Inukjuak sealift docks to the Inukjuak Upper Air Station, Inukjuak QC. The shipping container has designated crane lift points. The foundation blocks will be on pallets.

4.0 TASKS (Refer to Figure 1 for location details)

Tasks outlined within this Statement of Work are dependent on the timing of those outlined within other Contracts. This may lead to delays between the requirements listed below. Please work with the Technical Authority to coordinate schedules and minimize delays.

4.1. REQUIREMENTS

4.1.1 ARLS

The Contractor must complete the following tasks while abiding by section 4.2 General Details below:

- a. Loading, transportation, and unloading of 4 precast foundation blocks (supplied by MSC) as per Figure 1 and Vaisala pre-install guide section 6.2
- b. Loading, transportation, unloading, and placement of ARLS following Vaisala's recommended lifting procedures (Vaisala pre-install guide section 7.5 and 8).
The placement of the ARLS unit may occur on a separate day from the transportation based on the timing of the foundation work.

4.1.2 AWS

The Contractor must complete the following tasks while abiding by section 4.2 General Details below:

- a. Loading, transportation, and unloading of 4 precast foundation blocks (supplied by MSC) as per Figures 1 and 2.

4.2 GENERAL DETAILS

- a. Contractor must supply crane capable of lifting and moving the 7.5 t ARLS container (recommended capacity of 75 metric tonnes)
- b. Contractor must supply material handling equipment (front end loader or other) capable of moving precast foundation blocks

4.3 OUT-OF-SCOPE

Trenching Services may be provided by others.

Electrical Services may be provided by others.

Foundation Services may be provided by others.

Underground PVC conduit may be installed by others.

Communication feeds, equipment, and terminations will be supplied by others.

5.0 DELIVERABLES

The Contractor must supply the Technical Authority with the following:

- a. A Schedule detailing estimated construction timeline.
- b. Specifications for all supplied materials (including part numbers)

6.0 WORK LOCATION

Materials and equipment will be moved from the Inukjuak sealift docks to the Inukjuak Upper Air Station in Inukjuak Quebec (5km distance between the docks and the Upper Air station).

Inukjuak Upper Air Station:

58°28'03"N, 78°04'41"W

150m SE of the Inukjuak Airport terminal

7.0 OFFICIAL LANGUAGES

All work can be performed in the language of your choosing, however, all correspondence with the Technical Authority must be completed in either English or French.

8.0 TRAVEL

Travel will not be paid under this contract. All travel to and from the location of work is the responsibility of the Contractor.

9.0 GOVERNMENT SUPPLIED MATERIAL

All materials required to complete the work outlined below are the responsibility of the Contractor except for the following:

Eight (8) Precast Foundation Blocks

ARLS unit

10.0 FIGURES

Figure 1 - Inukjuak Upper Air Layout



Red line– Existing Power Pole and proposed Electrical service trench (133m)

Brown line – proposed AWS buried conduit (136m)

Blue rectangle– existing gravel pad

Orange rectangle– proposed gravel pad location (11X16m)

Yellow polygon– ARLS location

Green square– AWS location



Figure 2 - AWS layout

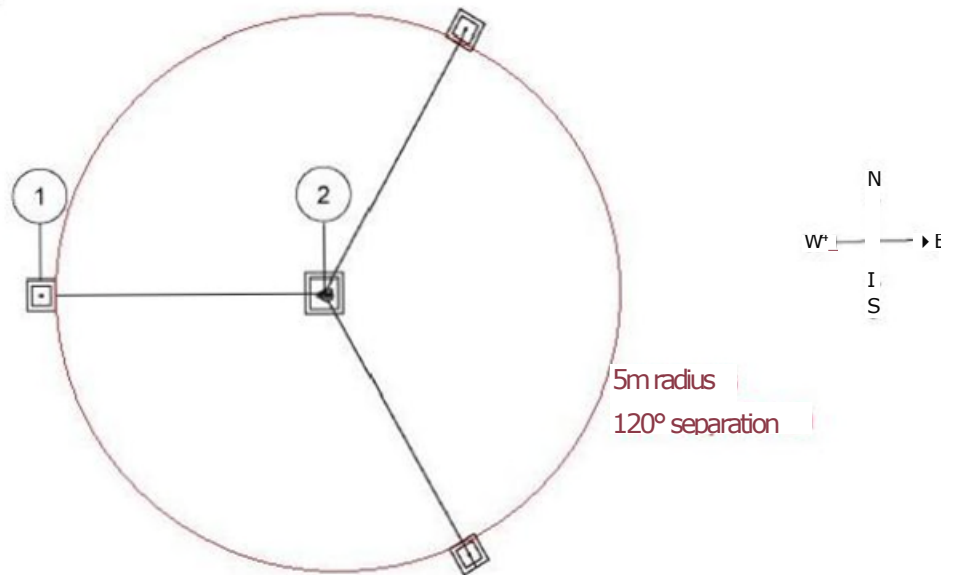

- 1 Guy wire 1 foundation
- 2 Mast foundation

ANNEX B BASIS OF PAYMENT

In consideration of the Contractor satisfactorily completing all of its obligations under the Contract, the Contractor will be reimbursed for the costs reasonably and properly incurred in the performance of the Work in accordance with the following:

A **maximum cost** of \$ (to be entered at contract award) for the satisfactory completion of all deliverables as described in the Statement of Work (SOW) and broken down as follows:

- A maximum of \$ (to be entered at contract award) for professional fees based on a rate of \$ (to be entered at contract award) per hour up to a maximum of (to be entered at contract award) hours;
- A maximum of \$ (to be entered at contract award) for parts; (if applicable)
- A maximum of \$ (to be entered at contract award) for equipment;
- A maximum \$ (to be entered at contract award) for travel expenses.

The Contractor will invoice for a one-time lump sum payment upon completion of the Work.

Limitation of expenditure

1. Canada's total liability to the Contractor under the Contract must not exceed \$ (to be entered at contract award). Customs duties are Included and Applicable Taxes are extra.
2. No increase in the total liability of Canada or in the price of the Work resulting from any design changes, modifications or interpretations of the Work, will be authorized or paid to the Contractor unless these design changes, modifications or interpretations have been approved, in writing, by the Contracting Authority before their incorporation into the Work. The Contractor must not perform any work or provide any service that would result in Canada's total liability being exceeded before obtaining the written approval of the Contracting Authority. The Contractor must notify the Contracting Authority in writing as to the adequacy of this sum:
 - a. when it is 75% committed, or
 - b. four months before the contract expiry date, or
 - c. as soon as the Contractor considers that the contract funds provided are inadequate for the completion of the Work, whichever comes first.



3. If the notification is for inadequate contract funds, the Contractor must provide to the Contracting Authority a written estimate for the additional funds required. Provision of such information by the Contractor does not increase Canada's liability.

Travel and Living Expenses – National Joint Council Travel Directive

The Contractor will be reimbursed for the authorized travel and living expenses reasonably and properly incurred in the performance of the Work, at cost, without any allowance for overhead or profit, in accordance with the meal and private vehicle allowances specified in Appendices B, C and D of the National Joint Council Travel Directive, and with the other provisions of the directive referring to "travellers", rather than those referring to "employees". Canada will not pay the Contractor any incidental expense allowance for authorized travel.

All travel must have the prior authorization of the Technical Authority.

All payments are subject to government audit.

Estimated cost: \$_____

ANNEX C INDIGENOUS BENEFITS PLAN

CLCA beneficiaries are not required to complete this section.

All other bidders should complete and submit this section as part of the bid per the bid submission instructions in Part 3.

PART A - INDIGENOUS BENEFITS PLAN (IBP)

Canada reserves the right to verify any information provided in the IBP and that untrue statements may result in the tender being declared non-responsive.

Definitions

Eligible Indigenous labourer:

1. An individual who is working on-site performing services related to the project for a contractor, subcontractor or supplier who has a contract with ECCC to do work related to the project; and
2. Must be an Indigenous person registered with Indigenous Services Canada, or on a membership list.

Inuit Firm Registry (IFR) Firm (prime contractor/subcontractor/supplier):

1. An IFR Firm shall be a firm, the name of which appears on the most current list of Inuit firms created in accordance with the requirements of Article 24.7.1 of the Agreement between the Inuit of the Nunavut Settlement area and Her Majesty the Queen in Right of Canada. <https://inuitfirm.tunnngavik.com/>

Indigenous Business Directory (IBD) Firm (prime contractor/subcontractor/supplier):

1. An IBD Firm shall be a firm, the name of which appears on the most current list of Indigenous Businesses created by Indigenous Services Canada. <https://www.sac-isc.gc.ca/REA-IBD/eng/reset>

Evaluation: Commitment

The Contractor must provide their IBP Commitments based on the Firm Requirement identified in Annex "B", Basis of Payment and the Financial Bid Preparation Sheet.

The Contractor will be assessed on their total IBP commitments. For example, in Indigenous Benefits Criteria (IBC), Indigenous Employment, if your commitment percentage is 20%, you should commit a minimum of 20% towards Indigenous Employment labour hours.

It is recommended that the Contractor provides an IBP Commitment Schedule detailing commitments for each criteria. If this schedule is provided, Canada may use the IBP Commitment Schedule to assess the annual commitment percentage instead.



Bidders should provide a written plan of engagements, measures, and proposed procedures to be taken to deliver on the Indigenous Benefit Criteria (IBC) identified in the tables below.

For a bid to be assigned points for commitments made in respect to any IBP bid criteria, the Bidder should provide proof to demonstrate how they will meet the objective of each criterion. Bidders should use the commitment tables in Part B to detail their commitment.

Commitment Tables

The tables in Part B should be used by bidders to submit their proposals and to supplement their response.

If the Commitment Tables for each IBP criteria has not been provided at bid closing, the Contracting Authority will notify the Bidder that they must provide the Commitment Tables within two (2) business days following notification. Failure to comply with the request of the Contracting Authority within that time period, a score of zero (0) will be allocated for the Commitment requirement, as applicable.

For follow-up purposes, the communities may receive copies of the Contractor’s Indigenous Benefits Plan and periodically receive performance monitoring results. Each commitment value will be confirmed during activities based on the commitment tables and supporting documentations provided by the Contractor and Technical Authority, as applicable.

Contractor Selection

For IBP commitment, to establish the commitment score, each responsive bid will be assigned points as detailed in the IBC table below.

The Contractor selection will be based on the highest responsive combined rating of IBP and price.

See **Part 4 - Evaluation Procedures and Basis of Selection** for details.

INDIGENOUS BENEFITS PLAN CRITERIA

The requirements of the James Bay and Norther Quebec Comprehensive Land Claim Agreement (JBNQA) and Northeastern Quebec Comprehensive Land Claim Agreement (NEQA) apply to this procurement. Canada reserves the right to confirm validity of all declarations / guarantees.

| Indigenous Benefits Criteria (IBC) | | |
|---|--|---------------|
| 1 | Indigenous Employment: to evaluate the employment of Indigenous Labour. | Points |
| | The employment of onsite Indigenous in carrying out the work under the contracts. Bidder will be evaluated on their firm guarantee to use Indigenous labour in carrying out the work. The percentages identified below relate specifically to on-site labour hours regardless of whether they are Prime Contractor staff and/or Subcontractor staff. Percentages should be supported by a list of specific positions that | /10 |

| | | | | |
|----------|---|---|---|--|
| | <p>may or will be staffed by onsite Indigenous. Onsite Indigenous employment will be confirmed during activities based on supporting documentation provided by the Contractor and Technical Authority if applicable.</p> <p>0-100% of total labour hours = 0-10 points. Points will be assigned based on a percentage % of the total Points available.</p> <p>___ % x total points available</p> <p>Example:</p> <p>Bidder guarantees 65% of total labour hours will be Indigenous = 65 % x 10 = 6.5 points</p> <p>NOTE: Bidders must demonstrate how they will meet their Labour %. Simply indicating a “%” commitment is not sufficient to achieve points. Your score will be adjusted in accordance with your backup documentation (ie.labour plan estimate).</p> | | | |
| 2 | <p>Indigenous training and skills development: to evaluate the undertaking of commitments, under the contract, with respect to training or skills development for Indigenous.</p> | | | |
| | <p>Bidders will be evaluated on their undertaking of a commitment with respect to delivery of on-the-job training and apprenticeship programs for Indigenous labourers at no additional cost under this Contract.</p> <p>“Training and Apprenticeship” is considered delivered when the receiving individuals have acquired certifiable work skills and received certification. This is typically achieved through an independent third party certification process.</p> <p>To establish the training score, each responsive bid will be prorated against the Bidder proposing the highest number of total Indigenous training hours, with the proposal committing to the highest number of training hours receiving full points.</p> | /10 | | |
| | | Bidder 1 | Bidder 2 | Bidder 3 |
| | Total number of Indigenous training hours proposed | 20 hours | 35 hours | 60 hours |
| | Calculation of Points | 20/60 = 33 / 10 of total points available | 35/60 = 58 / 10 of total points available | 60/60 = 100 / 10 of total points available |
| 3 | <p>Indigenous ownership (prime contractor and/or subcontractors): to evaluate whether the Bidder is an Indigenous firm on the IFR or IBD, and whether Indigenous firms on the IFR or IBD will be engaged as subcontractor(s) in carrying out the government contract</p> | | | |



| | | |
|-------------------------------------|--|-----|
| | <p>The use of IFR or IBD prime contractor/subcontractors or suppliers in carrying out the contract.</p> <p>Bidders will be evaluated on their firm commitment to use IFR or IBD subcontractors for services or the procurement of supplies and equipment from IFR or IBD businesses.</p> <p>NOTE: If the Prime Contractor is an Inuit or Indigenous owned business, the total dollar value of the Inuit or Indigenous contracting shall also include the contractor's share of the contract.</p> <p>Bidders should provide their guarantee of Indigenous or Inuit prime contractor/subcontractor/supplier in accordance with the following:</p> <p>Estimated value of Contract: \$_____ - Less non-IFR/IBD contracting: \$_____ = Total guarantee of IFR/IBD contracting: \$_____</p> <p>Points will be assigned to bidder as follows:</p> <p>Total guaranteed of IFR or IBD contracting / Estimated value of contract = _____ x _____ total points available = assigned points</p> <p>Example: Estimated value of Contract: \$100,000 - less non-IFR/IBD contracting: \$ 45,000 = Total guarantee of IFR/IBD contracting: \$ 55,000</p> <p>\$55,000 / \$100,000 = 0.55 x 10 = 5.5 points</p> <p>NOTE: Inuit or Indigenous ownership MUST be supported by a list of specific contractor / subcontractor(s) / supplier(s) that can be confirmed as Inuit or Indigenous.</p> | /10 |
| JBNQA/NEQA Benefits Criteria | | |
| 4 | <p>Location in the Comprehensive Land Claims Agreement (CLCA) area: to evaluate whether the Bidder or the subcontractor(s) have head offices, administrative offices or other staffed facilities in the JBNQA and NEQA Areas.</p> | |
| | <p>Bidders will be evaluated on their new or existing location of business in the JBNQA and NEQA Areas in performing work under the government contract. A Bidder may have head offices, administrative offices, or other staffed facilities.</p> <p>A maximum of 5 points will be assigned for this criterion. Points will be assigned as follows:</p> <ol style="list-style-type: none"> 1. Head Office(s) (2 points) 2. Administrative Office(s) (2 points) 3. Other Staffed Facilities (1 point) | /5 |

| | | |
|--|---|--|
| | <p>Location Proposal Bidders must provide details regarding the locations submitted. Information to include:</p> <ul style="list-style-type: none"> • a description of the locations, including addresses; • describe the nature of the firm's presence in the JBNQA and NEQA Areas; and • number of years the firm has been in the identified location(s) in the JBNQA and NEQA Areas. | |
|--|---|--|

| Criteria | Total Points Available | Total Score |
|--|------------------------|-------------|
| Indigenous employment | 10 | /10 |
| Indigenous training and skills development | 10 | /10 |
| Indigenous ownership/sub-contractors/suppliers | 10 | /10 |
| Location in the JBNQA and NEQA Areas | 5 | /5 |
| Grand Total | | /35 |

PART B – BIDDER GUARANTEE AND CERTIFICATION

1. At time of bid submission - The tables below may be used by bidders to submit their proposals.
2. Information provided may be subject to verification.

Commitment Table 1 – Gurantee of Onsite Indigenous Labour

Total No. of onsite Indigenous Person Hours for this Contract = _____%
 Total No. of onsite Person Hours for this Contract

1-A Total On-site Indigenous Labour

| Column | | (A) | (B) | (C) |
|--------------------------------|-----------------------------|---|---------------------------------------|----------------------------|
| Name and/or Beneficiary Number | Employment Type or Position | Hourly Rate* (for the employment type or position) | Total On-site Indigenous Labour Hours | Total Dollar Value (A x B) |
| | | \$ | | \$ |
| | | \$ | | \$ |
| | | \$ | | \$ |
| | | \$ | | \$ |
| | | \$ | | \$ |
| Total | | | | \$ |

Table 1-B – Total On-site non-Indigenous Labour



| Column | | (A) | (B) | (C) |
|--------------|-----------------------------|---|---|----------------------------|
| Name | Employment Type or Position | Hourly Rate* (for the employment type or position) | Total On-site non-Indigenous Labour Hours | Total Dollar Value (A x B) |
| | | \$ | | \$ |
| | | \$ | | \$ |
| | | \$ | | \$ |
| | | \$ | | \$ |
| | | \$ | | \$ |
| Total | | | | \$ |

Note: *The hourly rate must be the dollar value in CAD to the employee for the estimated work to be performed under the government contract.

Commitment Table 2 – Gurantee of Indigenous Training

| Name & Position Title (provide name(s) where possible) | Type of Training | Indigenous Training Hours |
|--|------------------|---------------------------|
| Bidders to include the type of training and hours of training as applicable. | | |

Commitment Table 3 – Gurantee of Indigenous Ownership (Contractor/Subcontractor/Supplier)

Bidders must provide a written plan of engagements, measures, and proposed procedures for their deliver on the Indigenous Ownership (of prime or sub-contractor/suppliers) criteria. The following is information required, at a minimum, to demonstrate Indigenous ownership commitment:

- Demonstrable Inuit/Indigenous ownership of prime and/or subcontractor(s) through registration on the Inuit Firm Registry (IFR) OR Indigenous Business Directory (IBD);
- list of specific Inuit/Indigenous businesses that will be subcontractors/suppliers;
- the type of work to be carried out by Inuit/Indigenous businesses on the IFR/IBD;
- the total contract value of the work to be performed by Inuit/Indigenous businesses on the IFR/IBD.

3-A Total Indigenous/Inuit Contractor/Sub-Contracting/Supplier Commitment

| Company Name (Contractor) | Description of the Work | Indigenous/Inuit Firm ID | Dollar Value of Contractor Portion |
|--|-------------------------|--------------------------|------------------------------------|
| | | | \$ |
| Company Name (subcontractor/supplier) | Description of the Work | Indigenous/Inuit Firm ID | Dollar Value of the Subcontract or |

| | | | |
|--------------|--|--|--------------------------|
| | | | Supplies/Services |
| | | | \$ |
| | | | \$ |
| | | | \$ |
| | | | \$ |
| | | | \$ |
| Total | | | \$ |

3-B Total non-Indigenous/Inuit Sub-Contracting/Supplier Commitment

| Company Name (subcontractor/supplier) | Description of the Work | Dollar Value of the Subcontract or Supplies/Services |
|--|--------------------------------|---|
| | | \$ |
| | | \$ |
| | | \$ |
| | | \$ |
| | | \$ |
| Total | | \$ |

Commitment Table 4 – Guarantee of Location in the JBNQA and NEQA Areas

| Company Name (Contractor) | Address in the JBNQA and NEQA Areas | Nature of Presence and Office Type in the JBNQA and NEQA Areas |
|--|--|---|
| | | |
| Company Name (subcontractor/supplier) | Address in the JBNQA and NEQA Areas | Nature of Presence and Office Type in the JBNQA and NEQA Areas |
| | | |
| | | |
| | | |
| | | |



Bidder Certification

The Bidder must submit the following certification if an IBP guarantee is being provided, either at time of bid submission, or as requested by the Contracting Authority.

Indigenous Benefits Plan Certification:

PRINT NAME

SIGNATURE

DATE

The Bidder certifies its IBP guarantee for contracting submitted with its bid is accurate and complete.

PART C – CONTRACTOR ACHIEVEMENT REPORTING AND CERTIFICATION

Part C and D is for the successful Contractor only.

1. The Contractor must provide a summary of activities undertaken to meet the commitments made as part of the Indigenous Benefits Plan (IBP) portion of their bid. The Certification and Achievement tables below must be submitted with supporting information (such as invoices, work logs, payroll receipts, etc.) by the Contractor upon invoice submission. The information provided will be used for Part D – Assessment of Annual IBP Deduction.
2. This will include at a minimum a list of the achieved versus committed listed in the tables below.
3. The Contractor must indicate if any objectives were not met, identify why they were not, and explain how the situation will be remedied and within what timeframe.
4. Canada reserves the right to verify any information provided in the IBP.

Return Reports to:

Contracting Authority Name: Caitlin Andersen

Title: Senior Procurement Officer, Strategic Procurement and Governance

Email: Caitlin.Andersen@ec.gc.ca

Contractor Name: _____

The reports must be submitted at time of invoicing.

Reporting Table 1 – Achievement of Onsite Labour

Total No. Of onsite Indigenous Person Hours for this Contract = _____%

Total No. Of Employee Hours for this Contract

1-A Total On-site Indigenous Labour

| Column | | (A) | (B) | (C) |
|--------------------------------|-----------------------------|---|--|---------------------------------|
| Name and/or Beneficiary Number | Employment Type or Position | Hourly Rate Paid* (for the employment type or position) | Total On-site Indigenous Labour Hours Worked | Total Dollar Value Paid (A x B) |
| | | \$ | | \$ |
| | | \$ | | \$ |
| | | \$ | | \$ |
| | | \$ | | \$ |
| | | \$ | | \$ |
| Total | | | | \$ |

Table 1-B – Total On-site non-Indigenous Labour

| Column | | (A) | (B) | (C) |
|--------------|-----------------------------|---|--|---------------------------------|
| Name | Employment Type or Position | Hourly Rate Paid* (for the employment type or position) | Total On-site non-Indigenous Labour Hours Worked | Total Dollar Value Paid (A x B) |
| | | \$ | | \$ |
| | | \$ | | \$ |
| | | \$ | | \$ |
| | | \$ | | \$ |
| | | \$ | | \$ |
| Total | | | | \$ |

Note: *The hourly rate must be the dollar value paid in CAD to the employee for work performed under the government contract.

Reporting Table 2 – Achievement of Indigenous Training



| Name and/or Beneficiary Number of Indigenous Trainee | Position Title | Type of Training | Indigenous Training Hours |
|--|----------------|------------------|------------------------------|
| | | | |
| | | | |
| | | | |
| | | | |

**Reporting Table 3 – Achievement of Indigenous Ownership
(Contractor/Subcontractor/Supplier)**

3-A Total Indigenous Contractor/Sub-Contracting/Supplier Commitment

| Company Name (Contractor) | Description of the Work | Indigenous Firm ID | Dollar Value of Contractor Portion |
|--|-------------------------|-----------------------|--|
| | | | \$ |
| Company Name (subcontractor/supplier) | Description of the Work | Indigenous Firm ID | Dollar Value of the Subcontract or Supplies/Services |
| | | | \$ |
| | | | \$ |
| | | | \$ |
| | | | \$ |
| Total | | | \$ |

3-B Total non-Indigenous Sub-Contracting/Supplier Commitment

| Company Name (subcontractor/supplier) | Description of the Work | Dollar Value of the Subcontract or Supplies/Services |
|--|-------------------------|--|
| | | \$ |
| | | \$ |
| | | \$ |
| | | \$ |
| Total | | \$ |

Reporting Table 4 – Achievement of Location in the JBNQA and NEQA Areas

| | | |
|---|--|---|
| Company Name (Contractor) | Address in the JBNQA and NEQA Areas | Nature of Presence and Office Type in the JBNQA and NEQA Areas |
| | | |
| Company Name (subcontractor/supplier) | Address in the JBNQA and NEQA Areas | Nature of Presence and Office Type in the JBNQA and NEQA Areas |
| | | |
| | | |
| | | |
| | | |

Contractor Certification

| | | |
|--|------------------|-------------|
| Indigenous Benefit Plan Reporting Certification: | | |
| | | |
| _____ | _____ | _____ |
| PRINT NAME | SIGNATURE | DATE |
| The Contractor certifies the information contained in the REPORTING TABLES is accurate and complete. | | |

PART D – ASSESSMENT OF IBP DEDUCTION

Part C and D is for the successful Contractor only.

1. If the Contractor does not meet the certified percentage or commitment for each criteria, Canada may deduct up to the full Annual IBP Deduction Amount from the last invoice in accordance with the Annual IBP Assessment tables below.

The IBP Deduction Amount is calculated as follows:

$$\text{Step 1} \quad \frac{\text{IBP Total Dollar Value / Total Evaluated Price for the Firm Requirement (excluding option periods)}}{\text{}} = \text{IBP Deduction Percentage (\%)}$$

$$\text{Step 2} \quad \text{Annual Invoice Totals} \times \text{IBP Deduction Percentage (\%)} = \text{Annual IBP Deduction Amount}$$

Example:

| | |
|---|----------------|
| IBP Dollar Value (value determined from Part A) | \$100,000.00 |
| Total Evaluated Price for the Firm Requirement (value determined from Annex “B”): | \$1,000,000.00 |

$$\text{Step 1: } 100,000.00 / 1,000,000.00 = 10\% \text{ (IBP Deduction Percentage)}$$



10% represents the value of the Contract committed to IBP commitments.

| | |
|---|--------------|
| Annual Invoice Totals (value is determined based on all the total invoices from the year) | \$250,000.00 |
| IBP Deduction Percentage (%) (percentage calculated in Step 1) | 10% |

Step 2: \$250,000.00 x 10% = \$25,000.00 (Annual IBP Deduction Amount)

\$25,000.00 is the total amount Canada may deduct if the Contractor does not meet the certified percentage or commitment for each criteria for that year.

- The Contractor must provide a summary of activities undertaken to meet the commitments made as part of the IBP portion of their bid in Part C. The information provided will be used in the tables below to assess the Contractor's IBP Deduction.
- Canada reserves the right to verify any information provided in the IBP.
- Where a Contractor is unable to deliver the level of IBC or JBNQA/NEQA benefits committed in the IBP, the Contractor should submit proof of efforts demonstrated to achieve those benefits, at a level commensurate with IBP commitments made to Canada. Contractors who meet or exceed each of their IBP commitment(s) will receive full points for each due diligence criteria below.

| IBP DEDUCTION CHECKLIST: ANNUAL IBP ASSESSMENT | | |
|--|---|---------------|
| Step # | Contractor Name: _____ | |
| | Total IBP Value (excluding applicable taxes): \$ _____ | |
| Indigenous Benefits Criteria | | |
| 1 | On-Site Indigenous Labour | |
| | Percentage Proposed – Hours Commitment | _____ % |
| | Percentage Achieved – Hours Commitment | _____ % |
| | Met: No applicable IBP deduction Not Met: Proceed to Table 1 to determine applicable IBP deduction | Met / Not Met |
| | Percentage Proposed – Financial Commitment | _____ % |
| | Percentage Achieved – Financial Commitment | _____ % |
| | Met: No applicable IBP deduction Not Met: Proceed to Table 1 to determine applicable IBP deduction | Met / Not Met |
| 2 | Indigenous Training & Skills Development | |
| | Percentage Proposed – Hours Commitment | _____ % |
| | Percentage Achieved – Hours Commitment | _____ % |

| | | |
|-------------------------------------|--|---------------|
| | Met: No applicable IBP deduction Not Met: Proceed to Table 2 to determine applicable IBP deduction | Met / Not Met |
| 3 | Indigenous Ownership | |
| | Percentage Proposed | _____ % |
| | Percentage Achieved | _____ % |
| | Met: No applicable IBP deduction Not Met: Proceed to Table 3 to determine applicable IBP deduction | Met / Not Met |
| JBNQA/NEQA Benefits Criteria | | |
| 4 | Location of Business The Contractor must achieve a total score equal or equivalent to the score received during their initial bid evaluation, contractors receiving a score less than their initial score will be subject to an IBP deduction. | |
| | Evaluated Score at Contract Award | _____ points |
| | Points Achieved | _____ points |
| | Met: No applicable IBP deduction Not Met: Proceed to Table 4 to determine applicable IBP deduction | Met / Not Met |
| Annual IBP Deduction Amount | | |
| 5 | IBP Deduction Percentage (%) | _____ % |
| | Annual Invoice Totals | \$ _____ |
| | Annual IBP Deduction Amount | \$ _____ |
| 6 | Comments: | |

| TABLE 1 - ASSESSMENT OF ON-SITE INDIGENOUS LABOUR IBP DEDUCTION | | | |
|--|---|---------------|--------------|
| Item # | Requirement | Weight | Score |
| 1 | <p>Calculate the percentage of commitment achieved for on-site Indigenous labour based on the following formula, where:</p> <p>Achieved %: (a) Proposed %: (b) Percentage achieved %: (c)</p> <p>Score will be calculated as follows: (a) / (b) = (c) * 30</p> | 30 | |



| | | | |
|---|---|----------|--|
| | Note: If (c) is less than 50%, the Contractor will receive 0 points. If (a) is greater than (b), the Contractor will receive a max of 30 points. | | |
| 2 | <p>Calculate the percentage of commitment achieved for on-site Indigenous labour dollar value based on the following formula, where:</p> <p>Achieved %: (a) Proposed %: (b) Percentage achieved %: (c)</p> <p>Score will be calculated as follows: (a) / (b) = (c) * 30</p> <p>Note: If (c) is less than 50%, the Contractor will receive 0 points. If (a) is greater than (b), the Contractor will receive a max of 30 points.</p> | 30 | |
| 3 | <p>CONTRACTOR DUE DILIGENCE:</p> <p>Case-by-case-consideration is given to Contractor's ability to demonstrate diligent efforts to achieve on-site Indigenous employment commitments.</p> <p>Points awarded for Contractor due diligence based on the Following scale:</p> <p>0 points – No information submitted to demonstrate efforts to meet the IBP commitment.</p> <p>8 points – Contractor demonstrated little to no effort and made no Attempt to meet the IBP commitment.</p> <p>24 points - Contractor demonstrated moderate effort while attempting to meet the IBP commitment and attempted to mitigate shortfalls.</p> <p>40 points - Contractor demonstrated outstanding effort to meet the IBP commitment and were proactive to mitigate shortfalls.</p> | 40 | |
| 4 | TOTAL ASSESSED SCORE | 100 | |
| 5 | <p>TOTAL CALCULATED IBP DEDUCTION: (100 - Total Assessed Score)% x (30% x Annual IBP Deduction Amount) = Calculated IBP Deduction</p> | \$ _____ | |
| 6 | COMMENTS/JUSTIFICATIONS: | | |
| 7 | SIGNATURE OF EVALUATION PANEL: | | |

| | | |
|--|----------------------------|------------------------------|
| | Technical Authority | Contracting Authority |
| | _____ | _____ |
| | Signature | Signature |

| TABLE 2 - ASSESSMENT OF INDIGENOUS TRAINING IBP DEDUCTION | | | |
|--|---|-----------------|-------|
| Item # | Requirement | Weight | Score |
| 1 | <p>Calculate the percentage of commitment achieved for Indigenous training based on the following formula, where:</p> <p>Achieved %: (a) Proposed %: (b) Percentage achieved %: (c)</p> <p>Score will be calculated as follows: (a) / (b) = (c) * 60</p> <p>Note: If (c) is less than 50%, the Contractor will receive 0 points. If (a) is greater than (b), the Contractor will receive a max of 60 points.</p> | 60 | |
| 2 | <p>CONTRACTOR DUE DILIGENCE:</p> <p>Case-by-case-consideration is given to Contractor's ability to demonstrate diligent efforts to achieve Indigenous training commitments.</p> <p>Points awarded for Contractor due diligence based on the Following scale:</p> <p>0 points – No information submitted to demonstrate efforts to meet the IBP commitment.</p> <p>8 points – Contractor demonstrated little to no effort and made no Attempt to meet the IBP commitment.</p> <p>24 points - Contractor demonstrated moderate effort while attempting to meet the IBP commitment and attempted to mitigate shortfalls.</p> <p>40 points - Contractor demonstrated outstanding effort to meet the IBP commitment and were proactive to mitigate shortfalls.</p> | 40 | |
| 3 | TOTAL ASSESSED SCORE | 100 | |
| 4 | TOTAL CALCULATED IBP DEDUCTION: (100 - Total Assessed Score)% x (30% x Annual IBP | \$ _____ | |



| | | |
|---|--|------------------------------|
| | Deduction Amount) = Calculated IBP Deduction | |
| 5 | COMMENTS/JUSTIFICATIONS: | |
| 6 | SIGNATURE OF EVALUATION PANEL: | |
| | Technical Authority | Contracting Authority |
| | _____ | _____ |
| | Signature | Signature |

| TABLE 3 - ASSESSMENT OF INDIGENOUS OWNERSHIP IBP DEDUCTION | | | |
|---|---|---------------|--------------|
| Item # | Requirement | Weight | Score |
| 1 | <p>Calculate the percentage of commitment achieved for Indigenous ownership based on the following formula, where:</p> <p>Achieved %: (a) Proposed %: (b) Percentage achieved %: (c)</p> <p>Score will be calculated as follows: (a) / (b) = (c) * 60</p> <p>Note: If (c) is less than 50%, the Contractor will receive 0 points. If (a) is greater than (b), the Contractor will receive a max of 60 points.</p> | 60 | |
| 2 | <p>CONTRACTOR DUE DILIGENCE:</p> <p>Case-by-case-consideration is given to Contractor's ability to demonstrate diligent efforts to achieve Indigenous sub-contracting / supplier commitments.</p> <p>Points awarded for Contractor due diligence based on the Following scale:</p> <p>0 points – No information submitted to demonstrate efforts to meet the IBP commitment.</p> <p>8 points – Contractor demonstrated little to no effort and made no Attempt to meet the IBP commitment.</p> <p>24 points - Contractor demonstrated moderate effort while attempting to meet the IBP commitment and attempted to</p> | 40 | |

| | | | |
|----------|---|---|--|
| | mitigate shortfalls. 40 points - Contractor demonstrated outstanding effort to meet the IBP commitment and were proactive to mitigate shortfalls. | | |
| 3 | TOTAL ASSESSED SCORE | 100 | |
| 4 | TOTAL CALCULATED IBP DEDUCTION: (100 - Total Assessed Score)% x (30% x Annual IBP Deduction Amount) = Calculated IBP Deduction | \$ _____ | |
| 5 | COMMENTS/JUSTIFICATIONS: | | |
| 6 | SIGNATURE OF EVALUATION PANEL: | | |
| | Technical Authority _____ Signature | Contracting Authority _____ Signature | |

| TABLE 4 - ASSESSMENT OF LOCATION OF BUSINESS IBP DEDUCTION | | | |
|---|--|---------------|--------------|
| Item # | Requirement | Weight | Score |
| 1 | Demonstrate the existence of head offices, staffed administrative offices or other staffed facilities in the JBNQA and NEQA Areas. Calculate the score of commitments achieved for the existence of head offices, staffed administrative offices or other staffed facilities in the CBJNQ Area based on the following formula, where: Evaluated Score at contact award: (a) 1. Head Offices (40 points) | 100 | |



| | | | |
|----------|--|---|--|
| | <p>2. Administrative Offices (40 points) 3. Other Staffed Facilities (20 points)</p> <p>Note: If (b) is less than (a), the Contractor will receive 0 points. If (a) is equal or greater than (b), the Contractor will receive a max of 100 points.</p> | | |
| 2 | TOTAL ASSESSED SCORE | 100 | |
| 3 | <p>TOTAL CALCULATED IBP DEDUCTION: (100 - Total Assessed Score)% x (10% x Annual IBP Deduction Amount) = Calculated IBP Deduction</p> | \$ _____ | |
| 4 | COMMENTS/JUSTIFICATIONS: | | |
| 5 | SIGNATURE OF EVALUATION PANEL: | | |
| | <p>Technical Authority</p> <p>_____</p> <p>Signature</p> | <p>Contracting Authority</p> <p>_____</p> <p>Signature</p> | |