



## **RULES FOR BUILDING AND CLASSING**

---

# STEEL VESSELS UNDER 90 METERS (295 FEET) IN LENGTH 2017

## **PART 5 SPECIALIZED VESSELS AND SERVICES**

**American Bureau of Shipping  
Incorporated by Act of Legislature of  
the State of New York 1862**

**© 2016 American Bureau of Shipping. All rights reserved.  
ABS Plaza  
16855 Northchase Drive  
Houston, TX 77060 USA**

## Rule Change Notice (2017)

The effective date of each technical change since 1993 is shown in parenthesis at the end of the subsection/paragraph titles within the text of each Part. Unless a particular date and month are shown, the years in parentheses refer to the following effective dates:

(2000) and after	1 January 2000 (and subsequent years)	(1996)	9 May 1996
(1999)	12 May 1999	(1995)	15 May 1995
(1998)	13 May 1998	(1994)	9 May 1994
(1997)	19 May 1997	(1993)	11 May 1993

### Listing by Effective Dates of Changes from the 2016 Rules

**EFFECTIVE DATE 1 January 2017** – shown as (2017)

(based on the contract date for new construction between builder and Owner)

<i>Part/Para. No.</i>	<i>Title/Subject</i>	<i>Status/Remarks</i>
5-11-4/7 (New)	Articulated Tug and Barge Connection	To provide requirements for design and review of structure in way of connection.

PART  
**5**

Specialized Vessels and Services

**CONTENTS**

---

<b>CHAPTER 1</b>	<b>Vessels Intended for Navigation in Ice.....</b>	<b>1</b>
<b>CHAPTER 2</b>	<b>Vessels Intended to Carry Oil in Bulk.....</b>	<b>2</b>
<b>CHAPTER 3</b>	<b>Vessels Intended to Carry Ore or Bulk Cargoes .....</b>	<b>3</b>
<b>CHAPTER 4</b>	<b>Vessels Intended to Carry Liquefied Gases and Chemical Cargoes.....</b>	<b>4</b>
<b>CHAPTER 5</b>	<b>Vessels Intended to Carry Passengers .....</b>	<b>5</b>
<b>CHAPTER 6</b>	<b>Vessels Intended to Carry Containers.....</b>	<b>6</b>
<b>CHAPTER 7</b>	<b>Vessels Intended to Carry Vehicles.....</b>	<b>7</b>
<b>CHAPTER 8</b>	<b>Fire Fighting Vessels .....</b>	<b>8</b>
<b>CHAPTER 9</b>	<b>Oil Recovery Vessels .....</b>	<b>9</b>
<b>CHAPTER 10</b>	<b>Escort Vessels.....</b>	<b>10</b>
<b>CHAPTER 11</b>	<b>Vessels Intended for Towing.....</b>	<b>11</b>
	Section 1 General .....	13
	Section 2 Stability .....	15
	Section 3 Towing Gear .....	16
	Section 4 Vessel Design .....	17
	Section 5 Equipment.....	18
	Section 6 Tests .....	19
	Appendix 1 Intact Stability Guidelines for Towing Vessels.....	20
	Appendix 2 Guidelines for Bollard Pull Test Procedure.....	23
<b>CHAPTER 12</b>	<b>Fishing Vessels .....</b>	<b>25</b>
	Section 1 General .....	29
	Section 2 Vessel Design .....	31
	Section 3 Subdivision and Stability – General.....	36

Section 4	Intact Stability.....	39
Section 5	Damage Stability.....	59
Section 6	Equipment.....	62
Section 7	Machinery Equipment and Systems .....	63
Section 8	Ammonia Refrigeration Systems .....	64
Section 9	Safety Requirements .....	77
Section 10	Surveys .....	80

<b>APPENDIX 1</b>	<b>Requirements for Building and Classing Vessels Intended for Service in Domestic Waters .....</b>	<b>81</b>
-------------------	---	-----------

PART  
**5**

CHAPTER 1 Vessels Intended for Navigation in Ice (1 July 2015)

1 Application

The requirements for vessels intended for navigation in ice are specified in Part 6, Chapter 1 of the *Steel Vessel Rules*.

3 Notations

Vessels complying with the above requirements may be assigned the following notations, as applicable:

**TABLE 1**  
**Ice Class Notations (1 July 2015)**

<i>Polar Class</i> (SVR 6-1-1, 6-1-2, 6-1-3)	<i>Polar Class, Enhanced</i> (SVR 6-1-4)	<i>First-year Ice Class</i> (SVR 6-1-5)	<i>Baltic Class</i> (SVR 6-1-6)
<b>PC1</b>	<b>PC1, Enhanced</b>		
<b>PC2</b>	<b>PC2, Enhanced</b>		
<b>PC3</b>	<b>PC3, Enhanced</b>		
<b>PC4</b>	<b>PC4, Enhanced</b>		
<b>PC5</b>	<b>PC5, Enhanced</b>		
<b>PC6</b>	<b>PC6, Enhanced</b>		<b>1AA</b>
<b>PC7</b>	<b>PC7, Enhanced</b>	<b>A0</b>	<b>1A</b>
		<b>B0</b>	<b>1B</b>
		<b>C0</b>	<b>1C</b>
		<b>D0</b>	
		<b>E0</b>	

*Note:* The shaded ice classes are eligible for **Ice Breaker** class notation.

## PART

# 5

## CHAPTER 2 Vessels Intended to Carry Oil in Bulk (1 July 2015)

### 1 Application

The requirements for vessels intended to carry oil in bulk are specified in Part 5C, Chapter 2 of the *Steel Vessel Rules*.

### 3 Notations

Vessels designed for the carriage of oil cargoes in bulk and built to the above requirements and other relevant sections of the Rules may be assigned the notation **✕ A1 Oil Carrier**. As used in the Rules, the term “oil” refers to petroleum products having flash points at or below 60°C (140°F), closed cup test, and specific gravity of not over 1.05.

Vessels intended to carry fuel oil having a flash point above 60°C (140°F), closed cup test, and which comply with the above requirements and other relevant sections of the Rules, with the exception that the requirements for cofferdams, gas-tight bulkheads and aluminum paint may be modified may be assigned the notation **✕ A1 Fuel Oil Carrier**.

PART

5

CHAPTER 3 Vessels Intended to Carry Ore or Bulk Cargoes  
(1 July 2015)

1 Application

The requirements for vessels intended to carry ore or bulk cargoes are specified in Part 5C, Chapter 4 of the *Steel Vessel Rules*.

3 Notations

Vessels designed for the carriage of bulk cargoes or ore cargoes, and built to the above requirements and other relevant sections of the Rules may be assigned the notation **✘ A1 Bulk Carrier** or **✘ A1 Ore Carrier**.

## PART

# 5

## CHAPTER 4 Vessels Intended to Carry Liquefied Gases and Chemical Cargoes (1 July 2015)

### 1 Application

The requirements for vessels intended to carry liquefied gases are specified in Part 5C, Chapter 8 of the *Steel Vessel Rules* and the requirements for vessels intended to carry chemical cargoes are specified in Part 5C, Chapter 9 of the *Steel Vessel Rules*.

### 3 Notations

#### 3.1 Vessels Intended to Carry Liquefied Gases

Vessels designed and specifically fitted for the carriage of liquefied gases and built to the requirements specified in Part 5C, Chapter 8 of the *Steel Vessel Rules* and other relevant sections of the Rules may be assigned the notation **✘ A1 Liquefied Gas Carrier**.

Vessels designed for the carriage of liquefied natural gas, of which the methane content is more than 80% and built to the above requirements and other relevant sections of the Rules may be assigned the notation **✘ A1 Liquefied Natural Gas Carrier**.

#### 3.3 Vessels Intended to Carry Chemical Cargoes

Vessels designed and specifically fitted for the carriage of dangerous or noxious liquid chemical substances, and built to the requirements specified in Part 5C, Chapter 9 of the *Steel Vessel Rules* and other relevant sections of the Rules may be assigned the notation **✘ A1 Chemical Carrier**.



PART

5

CHAPTER 5 Vessels Intended to Carry Passengers (1 July 2015)

1 Application

The requirements for vessels intended to carry passengers are specified in Part 5C, Chapter 7 of the *Steel Vessel Rules*.

3 Notation

Vessels designed and specifically fitted for the carriage of passengers, and built to the above requirements and other relevant sections of the Rules may be assigned the notation **✕ A1 Passenger Vessel**.

PART

# 5

## CHAPTER 6 Vessels Intended to Carry Containers (1 July 2015)

### 1 Application

The requirements for vessels intended to carry containers are specified in Part 5C, Chapter 6 of the *Steel Vessel Rules*.

### 3 Notation

Vessels designed for the carriage of containers, and built to the above requirements and other relevant sections of the Rules may be assigned the notation **☒ A1 Container Carrier**.

PART

# 5

## CHAPTER 7 Vessels Intended to Carry Vehicles (1 July 2015)

### 1 Application

The requirements for vessels intended to carry vehicles are specified in Part 5C, Chapter 10 of the *Steel Vessel Rules*.

### 3 Notations

#### 3.1 Vehicle Carrier

Vessels designed and primarily fitted for the carriage of vehicles and built to the requirements of Section 5C-10-2 of the *Steel Vessel Rules* and other relevant sections of the Rules may be assigned the notation **☒ A1 Vehicle Carrier**.

#### 3.3 Vehicle Passenger Ferry

Vessels designed and fitted for the carriage of both passengers and vehicles and built to the requirements of Section 5C-10-3 of the *Steel Vessel Rules* and other relevant sections of the Rules may be assigned the notation **☒ A1 Vehicle Passenger Ferry**.

PART

5

CHAPTER 8 Fire Fighting Vessels (1 July 2015)

1 Application

The requirements for fire fighting vessels are specified in Part 5, Chapter 4 of the *OSV Rules*.

3 Notations

3.1 **FFV 1**

Vessels with water spray protection for cooling the Fire Fighting Vessel's surfaces to enable close operation for early stages of fire fighting and rescue operations, with capabilities in accordance with 5-4-1/Table 1 of the *OSV Rules*, built in compliance with the above requirements and other relevant sections of the Rules may be assigned the notation **☒ A1 FFV 1**.

3.3 **FFV 2 or FFV 3**

Vessels built in compliance with the above requirements and for continuous fighting of large fires and cooling structures on fire, with capabilities in accordance with 5-4-1/Table 1 of the *OSV Rules*, and other relevant sections of the Rules may be assigned the notation **☒ A1 FFV 2** or **☒ A1 FFV 3**.

3.5 **FFV 1 and 2**

Vessels with the notation **☒ A1 FFV 2** that also meet the requirements for **☒ A1 FFV 1** may be assigned the notation **☒ A1 FFV 1 and 2**.

3.7 **FFV 1 and 3**

Vessels with the notation **☒ A1 FFV 3** that also meet the requirements for **☒ A1 FFV 1** may be assigned the notation **☒ A1 FFV 1 and 3**.

3.9 **FF Capable**

Vessels not in full compliance with the Rules or not specifically built for the service intended to be covered by the Rules, but which have some fire fighting capability in addition to their regular service, may be considered and reviewed under the intent of the Rules, in relation to the specific fire fighting requirements, and may be distinguished in the *Record* with their assigned designation followed by the designation (**FF Capable**), such as **☒ A1 Towing Vessel (FF Capable)**, with detailed data on the extent of this capability entered into the *Record*. Such special fire fighting systems will be subject to annual surveys.

PART

5

CHAPTER 9 Oil Recovery Vessels (1 July 2015)

1 Application

The requirements for oil recovery vessels are specified in Part 5, Chapter 6 of the *OSV Rules*.

3 Notations

3.1 **OSR-S1**

Vessels built in compliance with the above requirements for recovery of oil of unknown flash points and outfitted for the same in accordance with Sections 5-6-3 and 5-6-4 of the *OSV Rules* and other relevant sections of the Rules, and approved for oil recovery service at the assigned freeboard may be assigned the notation **A1 OSR-S1**.

3.3 **OSR-S2**

Vessels built in compliance with the above requirements for recovery of oil having a flash point exceeding 60°C (140°F) and outfitted for the same in accordance with Section 5-6-6 of the *OSV Rules* and other relevant sections of the Rules, and approved for oil recovery service at the assigned freeboard may be assigned the notation **A1 OSR-S2**.

3.5 **OSR-C1**

Vessels built in compliance with the above requirements for recovery of oil of unknown flash points but not outfitted for the same in accordance with Section 5-6-5 of the *OSV Rules* and other relevant sections of the Rules, and approved for oil recovery service at the assigned freeboard may be assigned the notation **OSR-C1** [e.g., **A1 Towing Vessel (OSR-C1)**].

3.7 **OSR-C2**

Vessels built in compliance with the above requirements for recovery of oil having a flash point exceeding 60°C (140°F) but not outfitted for the same in accordance with Section 5-6-7 of the *OSV Rules* and other relevant sections of the Rules, and approved for oil recovery service at the assigned freeboard may be assigned the notation **OSR-C2** [e.g., **A1 Towing Vessel (OSR-C2)**].

PART

5

CHAPTER 10 Escort Vessels (1 July 2015)

1 Application

The requirements for escort vessels are specified in Part 5, Chapter 13 of the *OSV Rules*.

3 Notations

**3.1 Escort Vessels**

Vessels designed and built to the above requirements and other relevant sections of the Rules may be assigned the notation **✘ A1 Escort Vessel**.

**3.3 Dual Purpose Vessels**

Vessels intended for escort operations and providing additional services may be classed with combinations of the applicable notations for the relevant service [e.g., **✘ A1 ⊕ Escort Vessel (FFV 2)**] as explained in Section 5-1-1 of the *OSV Rules*.

In such instances, the dual or multipurpose vessel is to be designed and built to these requirements, as well as to those applicable for the particular additional service or services.

PART  
5

CHAPTER 11 Vessels Intended for Towing

**CONTENTS**

---

<b>SECTION 1</b>	<b>General</b> .....	<b>13</b>
1	Application .....	13
3	Classification .....	13
3.1	Tugs .....	13
3.3	Dual Purpose Vessels .....	13
5	Optional Record Entries.....	13
5.1	Quick Release .....	13
7	Submission of Data.....	13
9	Definitions .....	14
9.1	Static Bollard Pull .....	14
9.3	Reference Load.....	14
<b>SECTION 2</b>	<b>Stability</b> .....	<b>15</b>
1	Intact Stability During Tow .....	15
<b>SECTION 3</b>	<b>Towing Gear</b> .....	<b>16</b>
1	Arrangement .....	16
3	Quick Release Device.....	16
5	Strength.....	16
5.1	Towline.....	16
5.3	Towing Hook, Towing Winch, Towing Bollard and Towing Bitts ....	16
5.5	Supporting Structures.....	16
5.7	Connections .....	16
<b>SECTION 4</b>	<b>Vessel Design</b> .....	<b>17</b>
1	Side Shell and Frames.....	17
3	After Deck .....	17
5	Weather Deck Openings.....	17
7	Articulated Tug and Barge Connection.....	17
<b>SECTION 5</b>	<b>Equipment</b> .....	<b>18</b>
<b>SECTION 6</b>	<b>Tests</b> .....	<b>19</b>
1	Quick Release Test.....	19
3	Static Bollard Pull Test.....	19

<b>APPENDIX 1</b>	<b>Intact Stability Guidelines for Towing Vessels .....</b>	<b>20</b>
1	General .....	20
3	Submission of Plans .....	20
5	Intact Stability Criteria .....	20
7	Standard Loading Conditions.....	21
7.1	Loading Conditions .....	21
7.3	Load Considerations .....	21
9	Heeling Arm Curve.....	21
11	Trim and Stability Booklet .....	22
TABLE 1	Towline Pull Force.....	22
FIGURE 1	Righting Arm and Heeling Arm Curves .....	21
<b>APPENDIX 2</b>	<b>Guidelines for Bollard Pull Test Procedure .....</b>	<b>23</b>
1	General .....	23
3	Steady Bollard Pull Test Requirements .....	23



## PART

# 5

## CHAPTER 11 Vessels Intended for Towing

### SECTION 1 General

#### 1 Application

The requirements in this section apply to vessels intended for unrestricted towing service.

#### 3 Classification

##### 3.1 Tugs

In accordance with 1-1-3/3 of the *ABS Rules for Conditions of Classification (Part 1)*, the classification **✕ A1 Towing Vessel** is to be assigned to vessels designed primarily for towing service and built to the requirements of this section and other relevant sections of the Rules.

##### 3.1.1 Bollard Pull (2001)

The static bollard pull, determined by an approved bollard pull test in the presence of the Surveyor, will be indicated in the *Record*. See 5-11-6/3.

##### 3.3 Dual Purpose Vessels

Vessels intended for towing and other services, such as supplying stores to offshore units and installations, may be classed **✕ A1 Towing Vessel**.

Alternatively, at the request of the Owner, these vessels may be classed **✕ A1** with an appropriate notation in column 5 of the *Record*, for example, **Combination Tug & Support Vessel**.

In both instances, the dual purpose vessel is to be designed and built to these requirements, in addition to those as may be applicable for the particular services.

#### 5 Optional Record Entries

##### 5.1 Quick Release

At the request of the owner and where a remotely controlled quick release device is provided for the towing hook or towing winch, in accordance with 5-11-3/3, 5-11-3/5.3 and 5-11-6/1, the letters **QR** will be entered in the column 5 of the *Record*.

#### 7 Submission of Data

In general, in addition to the plans listed in 1-1-4/1 of the Supplement to the *ABS Rules for Conditions of Classification (Part 1)* and 4-1-1/7 of these Rules, the following plans and particulars are to be submitted.

- Structural details and arrangements of the structures in way of the towing hook, towing winch, or towing bollards, or bits, towing guide rollers and fairleads.
- Details of connections (See 5-11-3/5.7).
- Braking power of winch.
- (2001) Estimated static bollard pull, together with the method of prediction. (The estimated value is to be confirmed at Trials prior to certification.)

- Minimum specified breaking strength of towline.
- Stability data and calculations.
- (2001) Static Bollard Pull Test Procedure.

## 9 Definitions

### 9.1 Static Bollard Pull (2001)

Static bollard pull (*BP*) for use in 5-11-1/9.3 is the value submitted by the designer, in accordance with 5-11-1/7.

Static bollard pull will be entered in the *Record*, in accordance with 5-11-1/3.1. *BP* for use in 5-11-1/9.3 is to be taken as not less than the design value nor more than the value obtained by testing and published in the *Record*. See 5-11-6/3.

### 9.3 Reference Load

Reference Load (*RL*) in the design and testing of towing gear is  $2BP$ . For *BP* greater than 51 tf (50 Ltf), consideration will be given to a reduction in *RL*. For a *BP* of 51 tf (50 Ltf), *RL* is  $2BP$  and for a *BP* of 153 tf (150 Ltf) or more, *RL* may be taken as  $1.33BP$ , with interpolation for intermediate values of *BP*.

PART

5

CHAPTER 11 Vessels Intended for Towing

SECTION 2 Stability

1 Intact Stability During Tow

The intact stability of the vessel for towing operation is to comply with a recognized standard. The submission of evidence showing approval by an Administration of stability of the vessel for the static bollard pull (see 5-11-1/9.1) will be acceptable. Alternatively, upon request, the review will be performed by ABS. See Appendix 5-11-A1 for ABS guidelines.

PART

5

CHAPTER 11 Vessels Intended for Towing

SECTION 3 Towing Gear

1 Arrangement

The towing hook, towing winch, towing bitt or towing bollard is to be located as low as is practicable, and close to, but abaft of, the center of gravity of the towing vessel in the expected towing condition.

Rollers or fairleads are to be arranged so as to contain the towline within the design limit of its sweep.

Effective means are to be provided to lead and restrain the towline over the stern of the towing vessel.

3 Quick Release Device

Where entry **QR** in column 5 of the *Record* is requested in accordance with 5-11-1/5.1, the quick release device for the towing hook or towing winch is to be operable from the bridge or other normally manned location in direct communication with the bridge. The quick release device is to disengage the towline at any combination of expected trim and heel.

5 Strength

5.1 Towline

The breaking strength of towline is to be not less than the Reference Load (*RL*). See 5-11-1/9.3.

5.3 Towing Hook, Towing Winch, Towing Bollard and Towing Bitts

The towing hook, towing winch, towing bollard and towing bitt are to be capable of sustaining *RL* without permanent deformation. These items are to comply with a recognized standard or code of practice. Name plates indicating the names of standard, rated load, speed, mass, etc., will be acceptable for that purpose. Other means for verifying compliance will also be considered.

The installation of these items is to be to the satisfaction of the Surveyor.

5.5 Supporting Structures

The stresses in the structures supporting the items in 5-11-3/5.3 are not to exceed the following under a pull of *RL* applied horizontally and within a range of 30 degrees from the centerline of the vessel on each side.

$$\text{Normal Stress} = 0.75Y$$

$$\text{Shear Stress} = 0.45Y$$

where

$$Y = \text{specified minimum tensile yield strength or yield point.}$$

In addition, the buckling strength is to be adequate for the above loading.

5.7 Connections

The size and arrangement of holding down bolts and welds for towing hook or towing winch are to be in accordance with a recognized standard.

PART

5

CHAPTER 11 Vessels Intended for Towing

SECTION 4 Vessel Design

1 Side Shell and Frames

For vessels subject to impact loadings during routines, it is recommended that side frames with section modulus 25% greater than that obtained from 3-2-5/3.1, 3-2-5/5.1 or 3-2-5/5.3 be considered. For side shell plating, see 3-2-2/5.3.

3 After Deck

Deck fittings within the sweep of towline are to be protected against contact by the towline and against the towline fouling.

5 Weather Deck Openings

Openings in the weather deck intended to be used at sea and leading to spaces below the freeboard or superstructure deck, including emergency exits, are to be protected as required in 3-2-12/23.3 with sill height of doors at least as required by 3-2-12/Table 1 for companionways.

Access openings, including emergency exits, are to be located clear of the towline sweep area.

7 Articulated Tug and Barge Connection (2017)

Structure in way of connection system, (i.e., webs, stringers, bulkheads, etc.) is to be in accordance with 5-3-1/13 of the *ABS Rules for Building and Classing Steel Barges*.

PART

# 5

CHAPTER 11 Vessels Intended for Towing

SECTION 5 Equipment

Equipment is to be in accordance with Section 3-5-1, except that the equipment number (EN) may be calculated using 3-5-1/3.5. The number, weight and sizes of equipment differing from 3-5-1/Table 1 may be specially considered for limited service. See also 1-1-3/11 of the *ABS Rules for Conditions of Classification (Part 1)*.

PART

5

CHAPTER 11 Vessels Intended for Towing

SECTION 6 Tests

In addition to the tests required by the relevant sections, the following tests are to be conducted to the satisfaction of the Surveyor.

1 Quick Release Test (2005)

Where the entry **QR** in the *Record* is requested in accordance with 5-11-1/5.1, the effectiveness of the quick release device is to be demonstrated during initial sea trial. The test is to be conducted to the manufacturer's recommendations.

3 Static Bollard Pull Test (1 July 2008)

The static bollard pull test procedure is to be submitted for review by the attending Surveyor in advance of the test.

The first vessel of a series is to have a bollard pull test conducted in all cases. The requirements for conducting a bollard pull test on vessels of duplicate design and built in a series will be specially considered on a case-by-case basis. However, a bollard pull test certificate will only be issued to those vessels for which the BP notation is requested and the bollard pull test is actually carried out.

The static bollard pull is to be measured with the tug at the maximum continuous rpm and at or near the maximum towing depth. The towed vessel is to be in ballast condition but need not be down to the summer load line mark.

The static bollard pull is the pull that is recorded over the state of equilibrium without any tendency to decline.

The depth of water under the keel in the testing area should be at least two times the vessel draft at amidships.

For additional test criteria, see Appendix 5-11-A2 "Guidelines for Bollard Pull Test Procedure" of these Rules.

## PART

# 5

## CHAPTER 11 Vessels Intended for Towing

### APPENDIX 1 Intact Stability Guidelines for Towing Vessels (1998)

#### 1 General

The intact stability of each towing vessel is to be evaluated for the loading conditions indicated in 5-11-A1/7 for compliance with the intact stability criteria in Section 5-11-2, and the results are to be submitted.

For every loading condition, which is to be shown in the Trim and Stability Booklet, the righting arm curve (GZ curve) should be plotted using the VCG corrected for the free surface effects of liquid in tanks.

#### 3 Submission of Plans

The following drawings are to be submitted with the Trim and Stability Booklet for our review:

- i) General arrangement plan
- ii) Capacity plan or table with centers of gravity
- iii) Lines plan
- iv) Hydrostatic curve or table
- v) Cross curves of stability
- vi) Downflooding angle versus draft curve. The downflooding angle is the first of the angle of heel at which openings in the hull, superstructures or deck houses which cannot be closed weathertight immerse.

#### 5 Intact Stability Criteria

The following stability criteria are to be complied with:

- i) The area under the righting lever curve (GZ curve) should not be less than 0.055 meter-radians (10.3 ft-degrees) up to  $\theta = 30^\circ$  angle of heel and not less than 0.09 meter-radians (16.9 ft-degrees) up to  $\theta = 40^\circ$  or the angle of flooding  $\theta_f$ , if this angle is less than  $40^\circ$ . Additionally, the area under the righting lever curve (GZ curve) between the angles of heel of  $30^\circ$  and  $40^\circ$  or between  $30^\circ$  and  $\theta_f$ , if this angle is less than  $40^\circ$ , is not to be less than 0.03 meter-radians (5.6 ft-degrees).
- ii) The righting lever GZ is to be at least 0.20 m (0.66 ft) at an angle of heel equal to or greater than  $30^\circ$ .
- iii) The maximum righting arm is to occur at an angle of heel not less than  $25^\circ$ .
- iv) The initial metacentric height,  $GM_0$ , is not to be less than 0.15 m (0.49 ft).
- v) The area of the residual dynamic stability (area between righting and heeling arm curves to the right of the first intercept) up to an angle of heel of  $40^\circ$  plus the angle of the first intercept ( $A_1 + A_2$ ), or the angle of downflooding, if this angle is less than  $40^\circ$  plus the angle of the first intercept ( $A_1$ ), should not be less than 0.09 meter-radians. (See 5-11-A1/Figure 1.)



**FIGURE 1**  
**Righting Arm and Heeling Arm Curves**

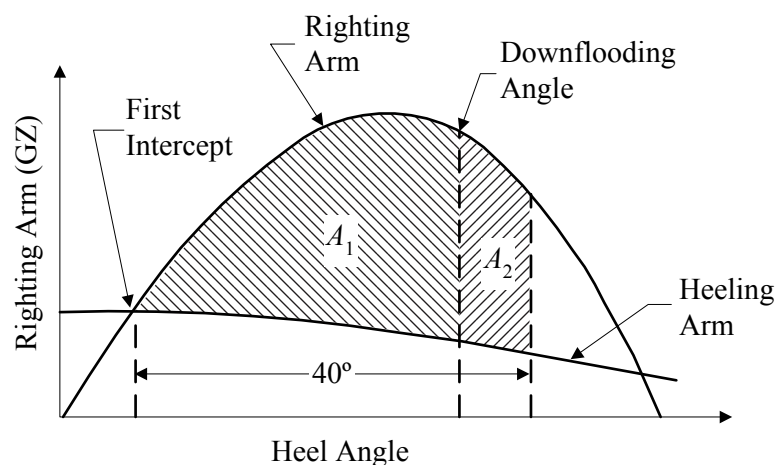

## 7 Standard Loading Conditions

### 7.1 Loading Conditions

The following conditions of loading are to be examined in the Trim and Stability Booklet:

- i) Vessel with full stores and fuel;
- ii) Vessel with 10 percent stores and fuel remaining;
- iii) Any other normal conditions, both departure and arrival that the Owner feels are appropriate or more suitable to the vessel's trade.

### 7.3 Load Considerations

The following are the assumptions for calculating loading conditions:

- i) In Loading Condition 5-11-A1/7.1i) above, it should be assumed that the vessel is loaded to its assigned load line with water ballast tanks empty.
- ii) If any loading condition water ballast is necessary, additional diagrams should be calculated, taking into account the water ballast. Its quantity and disposition should be stated.
- iii) In calculating the free surface corrections, it should be assumed that for each type of liquid, at least one transverse pair or a single centerline tank has a free surface and the tank or combination of tanks that is to be taken into account should be those where the effect of free surface is the greatest.

## 9 Heeling Arm Curve

The heeling moment due to the towline pull should be calculated using the corresponding percentage of the maximum bollard pull, depending on the type of propulsion (see below), at right angles to the vessel's fore and aft axis. The resultant moment should be converted to a heeling arm and plotted on the same graph as the righting arm curve (GZ curve). The heeling arm curve can be taken to vary with the cosine of the heeling angle.

Regarding the bollard pull force, the value is usually requested as it is derived from the actual test at maximum RPM. However, in preliminary considerations, a calculated value would be accepted based on the corresponding value of pounds of bollard pull force per SHP, depending on the type of propulsion (see 5-11-A1/Table 1). The heeling arm should be taken from the top of the towing bitt to the VCB or for an approximation to  $\frac{1}{2}$  the mean draft.

## 11 Trim and Stability Booklet

The Master of the vessel should receive information in the Trim and Stability Booklet regarding ballasting, towing, etc., to ensure that the stability is in compliance with the criteria given in 5-11-A1/5.

The Trim and Stability Booklet should also contain a table giving the free surface moments for all tanks designed for liquid. If any set of tanks are cross-connected, the free surface moment shall be calculated about the vessel's centerline.

**TABLE 1**  
**Towline Pull Force**

<i>Type of Propulsion</i>	<i>Bollard Pull (lbs/SHP)</i>	<i>Percentage of Bollard Pull at 90°</i>
Twin screw with open propellers, or other types not listed below	30	50%
Twin screw with open propellers and flank rudders	30	50%
Twin screw with conventional non-movable nozzles	35	50%
Water Tractor Tug with twin propeller Z-drives (steerable propellers with nozzles)	35	70%
Water Tractor with twin cycloidal propellers (vertical axis)	30	70%

PART

5

CHAPTER 11 Vessels Intended for Towing

APPENDIX 2 Guidelines for Bollard Pull Test Procedure (2001)

1 General

This Appendix is prepared as a guide for compliance with the requirements of 5-11-6/3.

Prior to conducting the steady bollard pull test, a written request should be received from the Owner of ABS attendance and addressing items 5-11-A2/3.15 and 5-11-A2/3.17 below. Only ABS-classed vessels may be attended for the test.

3 Steady Bollard Pull Test Requirements

3.1

The towing vessel should be on an even keel or trimmed to the intended operating condition in tow.

3.3

The draft of the towing vessel should be equal to or deeper than ballast condition, but need not be down to the summer load line mark.

3.5

Depth of water under the keel and on each side of the vessel should be at least  $2 \times$  vessel draft at midship.

3.7

If current exceeds 1 knot, its effect is to be subtracted from the bollard pull by either:

- i) Direct measurement of drag effect (pulling direction downstream) and reduction of bollard pull accordingly; or,
- ii) Conducting pull test both upstream and downstream and averaging the results.

3.9

The distance from the stern of the towing vessel to the bollard (fixed point) should be at least two ship lengths and be unobstructed by submerged pilings, bulwarks, etc.

3.11

Wind speed should be 10 mph or less, or such that it does not measurably affect the bollard pull results.

3.13

Sea condition should be calm.

3.15

A statement should be obtained from the vessel's Master or Owner's Representative that the propellers are those approved by ABS for the vessel.

**3.17**

The Owners should be satisfied as to the structural adequacy of the towing hawser, towing winch or tow bitts employed during the test.

**3.19**

The vessel's stability letter should include the towing condition.

**3.21**

The dynamometer (load cell) used for the test should be calibrated and suitable for use in the horizontal position. It should be fitted with swivels or should be torque insensitive, such as a hydraulic dynamometer. It should be easily read from a safe location or a remote readout should be provided. A continuous recording device is suggested but not mandatory. It is suggested that the maximum scale reading be, as a minimum, at least equal to [Max. Cont. Total H.P. × 50 (LBS.)]. The dynamometer should be located at the ashore end of the tow hawser.

**3.23**

The vessel's main engines should not be adjusted to operate in overload condition. Engine overspeed trip setting should be verified prior to commencing the test.

**3.25**

The Steady Bollard Pull should be computed as the average of evenly spaced load cell recordings taken over a sustained pull interval of three to five minutes. If the tow hawser is not horizontal, the vertical angle of the hawser is to be measured and used to obtain the actual horizontal thrust.

Engine temperatures should be at steady state during the test run. Engines should be operated at the ABS maximum continuous horsepower (certified horsepower per the *Record*) during the test. Instantaneous spike bollard pull readings should be ignored.

**3.27** (2006)

In general, two Surveyors are required when conducting the test, one ashore and one in the engine room. A two-way voice communication system is to be provided for the test.

When a survey is carried out at the initial testing for new construction, consideration may be given to conducting the test with one Surveyor in engine room where a continuous recording device suitably calibrated is used to record the bollard pull. This relaxation of two Surveyor requirements is to be included in a written request submitted as noted in 5-11-A2/1.

PART  
5

CHAPTER 12 Fishing Vessels (2001)

**CONTENTS**

<b>SECTION 1</b>	<b>General</b> .....	<b>29</b>
1	Application .....	29
3	Classification .....	29
5	Materials.....	29
7	Governmental and Other Regulations .....	29
9	International Conference on Safety of Fishing Vessels, 1977.....	30
11	Plans .....	30
13	Strengthening for Navigation in Ice.....	30
15	Refrigerated Fish Carrier .....	30
<b>SECTION 2</b>	<b>Vessel Design</b> .....	<b>31</b>
1	Fish Hold Bulkheads .....	31
1.1	General.....	31
1.3	Uprights.....	31
1.5	Portable Fish Hold Division .....	31
3	Side Shell – Local Strengthening.....	33
3.1	General.....	33
3.3	Vessels with Side Trawls.....	33
3.5	Vessels with Stern Trawls .....	33
5	Deck Plate.....	33
5.1	Local Reinforcement .....	33
7	Protection of Deck Openings .....	33
7.1	General.....	33
7.3	Hatchway Coamings, Companionway Sills and Access Sills .....	33
9	Bulwarks, Rails, Ports, Portlights and Ventilators.....	34
9.1	Details of Freeing Ports .....	34
9.3	Pound Boards.....	34
11	Miscellaneous .....	34
11.1	Storm Rails.....	34
11.3	Guard Rails, etc.....	34
11.5	Stern Doors .....	34
11.7	Drains .....	35
11.9	Chutes .....	35
13	Cargo Handling Equipment.....	35
TABLE 1	Coamings and Sill Heights.....	34
FIGURE 1	Horizontal Wood Boards – Steel Uprights .....	32

<b>SECTION 3</b>	<b>Subdivision and Stability – General</b> .....	<b>36</b>
1	Stability Requirements .....	36
1.1	Stability Information .....	36
1.3	Stability Standards.....	36
1.5	Lightship Determination .....	36
3	Plans .....	36
5	Freeboard and Limiting Draft Mark .....	37
7	Draft Marks.....	37
9	Review Procedures .....	37
9.1	Administration Review .....	37
9.3	ABS Review .....	37
11	Onboard Computers for Stability Calculations.....	38
<b>SECTION 4</b>	<b>Intact Stability</b> .....	<b>39</b>
1	Intact Stability – General.....	39
3	Intact Stability Criteria .....	39
3.1	General.....	39
3.3	Alternate Criteria .....	40
5	Severe Wind and Rolling Criteria.....	42
5.1	General .....	42
7	Treatment of Lifting Weights and Heeling Moments Due to Fishing Gear.....	45
7.1	General .....	45
7.3	Definitions .....	45
7.5	Heeling Moment Due to Onboard Crane Use .....	46
7.7	Heeling Moment Due to Fishing Gear .....	48
9	Standard Loading Conditions.....	49
9.1	Loading Conditions .....	49
9.3	Load Considerations .....	50
11	Design and Operating Factors Affecting Stability .....	51
11.1	Lightship and the Inclining Experiment .....	51
11.3	Calculation of Righting Arms.....	52
11.5	Free Surface Effects .....	52
11.7	Ballast.....	53
11.9	Watertight Integrity and Flooding .....	53
11.11	Icing .....	54
11.13	Water on Deck .....	55
13	Stability Guidance for the Master.....	57
TABLE 1	Values of Factor $X_1$ .....	45
TABLE 2	Values of Factor $X_2$ .....	45
TABLE 3	Values of Factor $k$ .....	45
TABLE 4	Values of Factor $s$ .....	45
TABLE 5	Values of $C_h$ .....	47

FIGURE 1A	Intact Stability Criteria for Fishing Vessels .....	40
FIGURE 1B	Alternate Intact Stability Criteria for Fishing Vessels .....	41
FIGURE 2	Severe Wind and Rolling Criteria.....	44
FIGURE 3	Crane Radius .....	46
FIGURE 4	Lifting Criteria .....	48
FIGURE 5	Calculating the Effect of a Fastened Trawl .....	49
FIGURE 6	Diagram of Key Watertight Closures .....	54
FIGURE 7	Method of Treatment of Water on Deck.....	56
FIGURE 8	Volume of Water to be Included in Calculating Effect of Water on Deck .....	57
<b>SECTION 5</b>	<b>Damage Stability .....</b>	<b>59</b>
1	Applicability .....	59
3	General .....	59
5	Damage Assumptions.....	59
7	Criteria.....	60
9	Permeability .....	60
11	Free Surface .....	60
13	Subdivision.....	61
<b>SECTION 6</b>	<b>Equipment.....</b>	<b>62</b>
1	Wire Rope .....	62
<b>SECTION 7</b>	<b>Machinery Equipment and Systems.....</b>	<b>63</b>
1	Inclinations .....	63
3	Liquid Petroleum Gas .....	63
5	Electrical Installation .....	63
5.1	General.....	63
5.3	Emergency Lighting.....	63
5.5	Cables – Construction .....	63
7	Refrigeration Plant .....	63
<b>SECTION 8</b>	<b>Ammonia Refrigeration Systems .....</b>	<b>64</b>
1	Application .....	64
1.1	Indirect Refrigeration Systems .....	64
1.3	Direct Expansion Refrigeration Systems .....	64
3	Refrigeration Machinery Space .....	64
3.1	General.....	64
3.3	Design Consideration .....	65
3.5	Materials.....	68
3.7	Personnel Safety Equipment .....	68
3.9	Safety Devices .....	68
3.11	Piping Arrangements.....	69
3.13	Electrical.....	69
3.15	Instrumentation, Control and Monitoring.....	70
3.17	Tests and Inspections .....	71

5	Process Area, Cargo Holds, and Bait Freezer Spaces.....	71
5.1	General .....	71
5.3	Design Considerations .....	72
5.5	Materials .....	74
5.7	Personnel Safety Equipment .....	74
5.9	Safety Devices .....	75
5.11	Piping Arrangements .....	75
5.13	Electrical .....	76
5.15	Instrumentation, Control and Monitoring .....	76
5.17	Test and Inspection .....	76
TABLE 1 Instrumentation and Alarms .....		70
<b>SECTION 9</b>	<b>Safety Requirements.....</b>	<b>77</b>
1	General .....	77
3	Fire Safety Measures .....	77
3.1	Structural Fire Protection .....	77
5	Life Saving Appliances and Equipment .....	78
5.1	Survival Craft .....	78
5.3	Personal Life Saving Appliances .....	78
5.5	Survival Craft Stowage, Embarkation and Launching Arrangements .....	78
7	Radio Communication Installations.....	78
9	Deck Coatings.....	79
11	Emergency Engine Kill Switch .....	79
13	Lifting Equipment Overload Trip .....	79
<b>SECTION 10</b>	<b>Surveys .....</b>	<b>80</b>
1	Surveys After Construction .....	80



PART

5

CHAPTER 12 Fishing Vessels (2001)

SECTION 1 General

1 Application (2014)

These requirements are intended to apply to vessels which meet the requirements of 5-12-1/3. Fishing Vessels that are intended solely for service in domestic waters are to comply with the requirements of this Section, and ABS may also consider the flag Administration's Ship Safety Regulations as an alternative in satisfying specific areas of the *ABS Rules for Building and Classing Steel Vessels Under 90 Meters (295 Feet) in Length* and this Chapter.

3 Classification (2014)

In accordance with 1-1-3/3 of the *ABS Rules for Conditions of Classification (Part 1)* the classification **✕ A1 Fishing Vessel** will be given to vessels which have been built to the satisfaction of the ABS Surveyors in accordance with these requirements and other relevant sections of the Rules and approved by the Committee for unrestricted service. In addition, as applicable, an entry will be made in the *Record* describing the vessel as **Side Trawl** or **Stern Trawl**.

The requirements of this Chapter are applicable to self-propelled fishing vessels under 90 meters (295 ft) in length that are commercially engaged in the catching, taking or harvesting of fish or an activity that is expected to result in the catching, taking or harvesting of the fish including fishing vessels which also process their catch. This Chapter is not intended to apply to vessels used exclusively for processing fish or other living resources of the sea, research or training, or fish carriers.

Where the vessel length exceeds 90 m (295 ft), the applicable requirements of this Section and the *Steel Vessel Rules* are to be used.

5 Materials (2014)

The requirements of this Chapter apply to welded vessels constructed of ordinary-strength steel complying with the requirements in the *ABS Rules for Building and Classing Steel Vessels Under 90 meters (295 feet) in Length*. Vessels constructed of aluminum or reinforced plastic material will be subject to special consideration. Other materials may be specially considered.

7 Governmental and Other Regulations

While these Rules cover the requirements for the classification of fishing vessels, the attention of Owners, designers, and builders is directed to the regulations of governmental, canal, and other authorities dealing with such matters as pollution control, emergency power supply, navigation aids, bilge pumping arrangements, piping details, fire protection.

## 9 International Conference on Safety of Fishing Vessels, 1977

Where authorized by the Administration of a country signatory to the International Conference on Safety of Fishing Vessels, 1977/1993 Protocol, and upon request of the Owners of an existing vessel or a vessel under construction, ABS will review plans and survey the vessel for compliance with the provisions of this Convention/Protocol and certify thereto in the manner prescribed in the Convention/Protocol.

Upon request of the Owner, ABS will review plans and survey an existing vessel or vessel under construction for compliance with the provisions of the International Conference on Safety of Fishing Vessels, 1977/1993 Protocol and will issue a special certificate certifying that the fishing vessel complies with this Convention/Protocol.

Where the vessel has been found to be in compliance with the provisions of the International Conference on Safety of Fishing Vessels, 1977/1993 Protocol, it will be distinguished in the *Record* by the words **Torremolinos Convention**.

## 11 Plans (2014)

In addition to the plans required to be submitted by Section 1-1-4 of the Supplement to the *ABS Rules for Conditions of Classification (Part 1)* and 4-1-1/7 of these Rules, the following plans are to be submitted in the same manner:

- Curves of Form (hydrostatic)
- Cross Curves of Stability
- Capacity Plan, giving centers of gravity and tank free surface corrections.

## 13 Strengthening for Navigation in Ice

Where it is intended to strengthen the vessel for navigation in Ice, and the Owner desires a notation in the *Record*, the vessel is to comply with the requirements in Part 6, Chapter 1 of the *Steel Vessel Rules*. It is the responsibility of the owner to determine which class is most suitable for his intended service.

## 15 Refrigerated Fish Carrier

Where Fishing Vessels are provided with facilities for chilling, cooling, or freezing and/or storage in the refrigerated cargo holds cooled by their own shipboard refrigeration machinery and the associated system the vessel is to comply with the requirements in Part 6, Chapter 2 of the *Steel Vessel Rules*.

## PART

## 5

## CHAPTER 12 Fishing Vessels (2001)

## SECTION 2 Vessel Design

## 1 Fish Hold Bulkheads

## 1.1 General

Where portable fish hold divisions are fitted, they are to be clearly indicated on the drawings submitted for review. Every portable fish hold division is to extend from the bottom of the hold to the deck.

## 1.3 Uprights (2014)

The section modulus of steel uprights (5-12-2/Figure 1) is not to be less than that obtained from the following equation.

$$SM = 4.0psbh^2 \text{ cm}^3 \qquad SM = 0.329 \times 10^{-4} psbh^2 \text{ in}^3$$

where

$s$	=	maximum transverse spacing between supports, in m (ft)
$b$	=	maximum longitudinal spacing between supports, in m (ft)
$h$	=	maximum unsupported span of the stanchion, in m (ft)
$p$	=	density of cargo, in metric tons/m <sup>3</sup> (lbs/ft <sup>3</sup> )

Where the uprights are permanent and welded attachments are provided at both ends, reduced scantlings can be considered on the end connections.

Where the uprights are constructed of aluminum, wood or other material, the scantlings will be specially considered. Due consideration is to be given for material strength and isolation of dissimilar metals.

## 1.5 Portable Fish Hold Division

## 1.5.1 Wooden Boards

The thickness of portable wooden boards (5-12-2/Figure 1) in centimeters (inches) is to be obtained from the following equations:

## 1.5.1(a) Horizontal boards

$$t = 2.83 \sqrt{(psb^2)} \text{ cm} \qquad t = 0.0235 \sqrt{(psb^2)} \text{ in.}$$

## 1.5.1(b) Vertical boards

$$t = 1.90 \sqrt{(ps\ell^2)} \text{ cm} \qquad t = 0.0157 \sqrt{(ps\ell^2)} \text{ in.}$$

where

$t$	=	thickness of wooden divisions, in cm (in.)
$\ell$	=	vertical span of wooden division, in cm (in.)

$p$ ,  $s$  and  $b$  are as defined in 5-12-2/1.3.

The formulae are applicable to longitudinal divisions. Where the divisions are athwartships the formulae should be modified by interchanging  $s$  and  $b$ . The thickness used may be rounded off to the nearest 3 mm ( $1/8$  in.) of the nearest standard thickness. The timber used is to be of durable quality, of a type and grade that has proved satisfactory for fish-hold divisions and the actual finished thickness of boards should be those derived from the equations. The thickness of the boards made of good quality hardwood may be reduced by 12.5 percent.

### 1.5.2 Metallic Boards

The section modulus of portable metallic boards is not to be less than that obtained from the following equation for horizontal or vertical members.

$$SM = 4kpasb^2 \text{ cm}^3 \qquad SM = 0.329 \times 10^{-4} kpasb^2 \text{ in}^3$$

where

- $a$  = width of metallic board, in m (ft)
- $\ell$  = unsupported span of vertical boards, in m (ft)
- $k$  = 1.0 for steel  
= 0.9 ( $Q_o$ ) for aluminum
- $Q_o$  =  $65/(Y_{al} + U_{al})$  SI/MKS Units  
=  $92000/(Y_{al} + U_{al})$  U.S. Units
- $U_{al}$  = minimum ultimate strength of the welded aluminum alloy under consideration, in kg/mm (psi)
- $Y_{al}$  = minimum yield strength of the welded aluminum alloy under consideration at 0.2% offset in a 254 mm (10 in.) gauge length, in kg/mm<sup>2</sup> (psi)

$p$ ,  $s$  and  $b$  are as defined in 5-12-2/1.3.

The formulae are applicable to longitudinal divisions. Where the divisions are athwartships the formulae should be modified by interchanging  $s$  and  $b$ .

**FIGURE 1**  
**Horizontal Wood Boards – Steel Uprights**

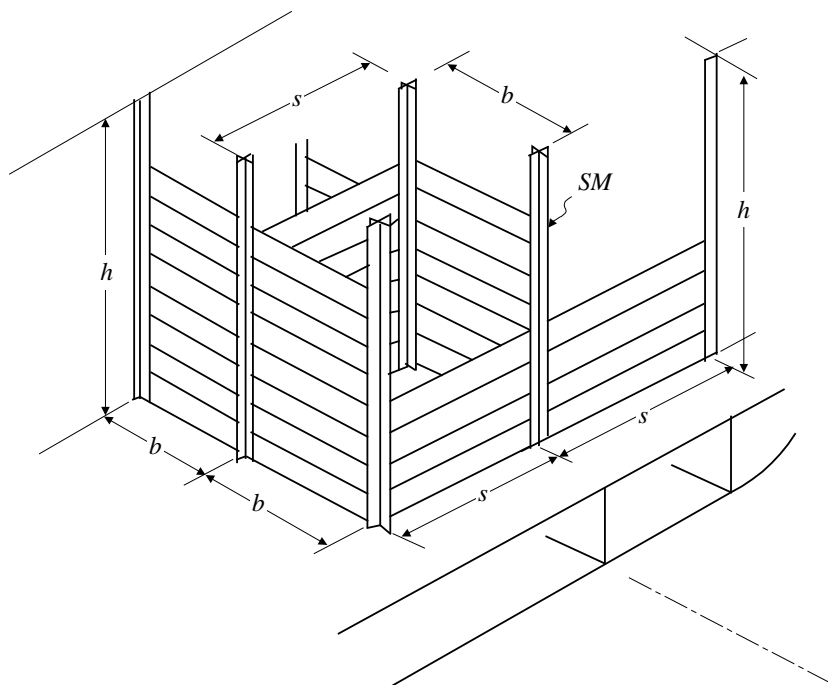

## 3 Side Shell – Local Strengthening

### 3.1 General

Wear plates or rollers are recommended at all places where fishing gear will subject the shell plating to accelerated wear. Special strengthening may be required in areas where small boats are regularly launched, retrieved, or stowed. Special strengthening may be required also in areas where the vessel makes contact with another vessel when pursuing, hauling, brailing, pumping, loading, unloading or running together.

### 3.3 Vessels with Side Trawls

In way of trawl gallows the minimum thickness of the side shell plating is to be 30% greater than the thickness of the side shell plating obtained from 3-2-2/5. In a vessel fitted with two or more gallows, the minimum thickness of the side shell plating between the gallows is to be 20% greater than the thickness of the side shell plating obtained from 3-2-2/5. Half round rub bars are to be installed at the top of the bulwark the top of the sheerstrake and at the designed waterline. These bars are to extend from not less than 150 mm (6 in.) forward of the forward leg of each gallow to not less than 305 mm (12 in.) aft of the forward gallow leg. Additional half-round rub bars are to be installed vertically or diagonally between the longitudinal rub bars in such a manner that shell plating welds are not subject to abrasion by the gear being handled by the gallows.

### 3.5 Vessels with Stern Trawls

The minimum thickness of the stern trawl chute is to be 30% greater than the thickness on the side shell plating obtained from 3-2-2/5. The minimum thickness of the chute sides is to be 10% greater than the thickness of the side shell plating obtained from 3-2-2/5. Wear plates are recommended at parts of the chute subject to accelerated wear.

## 5 Deck Plate

### 5.1 Local Reinforcement

The deck plating where subject to abrasion such as from the fishing gear is to be reinforced locally. The horizontal plating and the vertical plating are to be increased by approximately 30% and 10% respectively above the thickness of the deck plating in 3-2-3/3 or suitable deck coverings are to be provided. Positive means are to be provided to minimize the movement of the gear on deck due to the vessel motions in a seaway.

## 7 Protection of Deck Openings

### 7.1 General

All openings in decks are to be framed to provide efficient support and attachment for the ends of the deck beams. The proposed arrangements and details for all hatchways are to be submitted for approval.

### 7.3 Hatchway Coamings, Companionway Sills and Access Sills

The height above deck of coamings of hatchways, sills of companionways and access openings, is to be not less than given in 5-12-2/Table 1.

A companionway is a structure whose primary purpose is to protect an access in a deck. An access door in a superstructure or house is considered a companionway only if the access in a deck is adjacent to the door or if it is the sole access to the superstructure or house. A companionway opening, with a space or passageway and an inner joiner door with 100 mm (4 in.) sill, may have a sill height as required for access sills in 5-12-2/Table 1.

**TABLE 1**  
**Coamings and Sill Heights**

	<i>On Weather Deck</i>	<i>Deck Above Weather Deck</i>
<i>L equal to or over 24 meters (79 feet) in length</i>		
Hatch Coamings	600 mm (23.5 in.)	300 mm (12 in.)
Companionway sills	600 mm (23.5 in.)	300 mm (12 in.)
Access	380 mm (15 in.)	380 mm (15 in.)
<i>L under 24 meters (79 feet) in length</i>		
Hatch Coamings	300 mm (12 in.)	300 mm (12 in.)
Companionway sills	450 mm (17.5 in.)	300 mm (12 in.)
Access Sills	300 mm (12 in.)	230 mm (9 in.)

## 9 Bulwarks, Rails, Ports, Portlights and Ventilators

### 9.1 Details of Freeing Ports

Freeing ports are to be so arranged along the length of bulwarks as to ensure that the deck is freed of water most rapidly and effectively. Lower edges of freeing ports shall be as near the deck as practicable.

Freeing ports over 300 mm (11.8 in.) in depth are to be fitted with bars spaced not more than 230 mm (9 in.) nor less than 150 mm (6 in.) apart or provided with other suitable protective arrangements. Freeing port covers, if fitted, are to be submitted for review. If devices are considered necessary for locking freeing port covers during fishing operations they are to be easily operable from a readily accessible position.

In vessels intended to operate in areas subject to icing, covers and protective arrangements for freeing ports are to be capable of being easily removed to restrict ice accretion. The size of openings and means provided for removal of these protective arrangements are to be submitted for review.

### 9.3 Pound Boards

Pound boards and means for stowage of fishing gear are to be arranged so that the effectiveness of freeing ports will not be impaired. Pound boards are to be constructed that they can be locked in position when in use and shall not hamper the discharge of shipped water.

## 11 Miscellaneous

### 11.1 Storm Rails

Storm Rails are to be fitted on the outside of deck houses.

### 11.3 Guard Rails, etc. (2014)

Guard rails, gangways, lifelines or underdeck passages are to be provided for the crew to get between quarters, machinery spaces and other working areas. See also 3-2-14/1.5.

### 11.5 Stern Doors (2014)

Stern trawlers are to have doors, gates or other protective arrangements at the top of the stern ramp as high as the adjacent bulwark. A chain or other device should be provided to fit across the ramp when the doors are open. See also 3-2-13/23.

### 11.7 Drains (2014)

Adequate drainage facilities to be provided where fish handling or processing may cause water accumulation on deck, meeting the requirements of 4-4-2/23.

### 11.9 Chutes (2014)

Where chutes are used for the disposal of fish processing byproduct through the vessels side shell, they are to meet the requirements:

#### 11.9.1

The inboard end shall be located above the waterline formed by an 8.5 degree heel to port or starboard at the draft corresponding to the assigned summer freeboard, but not less than 1.0 m (3.3 feet) above the summer waterline.

#### 11.9.2

The chute is to be of substantial construction, not less than required by 3-2-2/5.1 and 3-2-2/5.5.

#### 11.9.3

The chute is to be provided with a hinged watertight cover at the inboard end of the chute together with a watertight discharge flap. The cover and flap shall be arranged with an interlock so that the discharge flap cannot be operated until the hopper cover is closed.

#### 11.9.4

The discharge flap structure is to be designed for pressures specified in 3-2-13/23.1.

#### 11.9.5

The hinged watertight cover is to comply with 3-2-12/23. It is to be provided with gaskets and a minimum of four clamping devices.

#### 11.9.6

The hinged cover shall be clearly marked: "Keep closed and secure when not in use".

## 13 Cargo Handling Equipment

For the Certification of cargo handling equipment, see Section 6-2-4 of the *Steel Vessel Rules*.

## PART

# 5

## CHAPTER 12 Fishing Vessels (2001)

### SECTION 3 Subdivision and Stability – General (2014)

#### 1 Stability Requirements

##### 1.1 Stability Information

Each vessel is to be provided with stability information in a format acceptable to ABS. The format may be pictorial, tabular, simplified trim and stability booklet, or other format that will provide a rapid means for the crew to evaluate the stability of the vessel. See 5-12-4/13.

Information is to be submitted on ballast, fuel, supplies and fish hold arrangement and capacities; summary and distribution of fixed and variable weights (including pots, traps, power-blocks, skiffs, wet nets, etc.) for each reviewed condition; and information on all loaded and ballasted conditions in which the vessel may be operated. See also Section 5-12-4.

Where the stability review has been conducted and found satisfactory by the flag State Administration, the stability information and calculations as required by Sections 5-12-4 and 5-12-5 need not be submitted.

##### 1.3 Stability Standards

The stability analysis is to be based on Sections 5-12-4 and 5-12-5, as applicable.

##### 1.5 Lightship Determination

The inclining experiment or lightweight survey, if applicable, is to be conducted on each fishing vessel upon completion and after modifications are made (see 5-12-4/11.1).

The responsibility for preparing the vessel for the test and conducting the test rests with the owner, shipbuilder or naval architect. The Surveyor will verify all of the data and will assist only as necessary to obtain valid test results. Where the inclining experiment is conducted by flag State Administrations, the Surveyor is to witness the inclining experiment. Also see 5-12-4/11.1.

#### 3 Plans

In addition to the plans required to be submitted by Section 1-1-4 of the Supplement to the ABS *Rules for Conditions of Classification (Part 1)* and 4-1-1/7 of these Rules, the following plans are to be submitted in the same manner:

- i) Lines and offsets
- ii) Curves of Form (hydrostatics), if not included in the Trim and Stability Booklet
- iii) Trim and Stability Booklet or simplified guidance for Master
- iv) General Arrangement Plan, with outboard profile
- v) Capacity Plan or Table with centers of gravity and free surface values for tanks and holds
- vi) Tank Sounding Tables, if not included in the Trim and Stability Booklet
- vii) Cross curves of stability, if not included in the Trim and Stability Booklet.
- viii) List of down-flooding points, including their transverse, longitudinal and vertical locations, used in the calculation of the intact and damage stability criteria.



- ix) *Draft Marks.* Drawing showing the draft mark details, longitudinal locations of marks fore and aft referenced to the forward and after perpendiculars or to the nearest frames and vertical reference points. Navigational draft marks should be based on the vessel's lowest vertical projection.
- x) Intact (and damage if required) stability calculations supporting the maximum KG or minimum GM curve
- xi) Stability Test Procedure
- xii) Stability Test Results

## 5 Freeboard and Limiting Draft Mark

The maximum permissible draft at amidships and its corresponding minimum freeboard are to be indicated on both sides of the vessel, amidships. The minimum freeboard corresponds to the maximum permissible draft at amidships for which the strength and stability of the vessel are approved.

## 7 Draft Marks

Vessels shall have permanent draft markings installed at the bow and stern to indicate the depth that the vessel extends below the waterline. The vertical extent of the draft marks shall be adequate to cover the draft of the vessel under all probable conditions of loading and corresponding trims with the ship undamaged.

Draft marks shall be block Arabic numerals, 100 mm in vertical projected height. The bottoms of the numerals shall correspond to multiples of 200 mm of draft. The draft mark numerals shall represent even intervals of decimeters and shall be in double or triple digits for whole meter draft marks and single digits for intermediate marks.

Alternatively, the use of U.S. customary units for markings is permitted. The draft marks shall be block Arabic numerals, 6 inches in vertical projected height. The bottoms of the numerals shall correspond to multiples of 1 foot of draft. The draft mark numerals shall represent even intervals of 1 foot and only the last digit shall be used except that both digits shall be used for drafts which are multiples of 10 feet and for the uppermost mark.

The units of the draft marks shall be consistent with the stability information provided to the Master.

Draft marks shall be provided, port and starboard, as near the bow and the stern as practicable with due regard for external fittings and the shape of the hull. Draft marks shall indicate the draft above the underside of the keel plate at their location except in cases where the keel is cut away at the bow or stern. Where the keel is cut away, the draft marks shall be located vertically so that zero draft is below the keel a distance equal to the designed rise of the keel at the location of the marks.

Draft marks shall be painted in a contrasting color to the surrounding hull so they are clearly visible.

## 9 Review Procedures

### 9.1 Administration Review

Stability approval by the Administration may be accepted as evidence that the vessel has subdivision and stability in accordance with or equivalent to Sections 5-12-4 and 5-12-5.

### 9.3 ABS Review

In all other cases, the information and calculations for subdivision and stability are to be submitted to ABS for review. On a case-by-case basis, the published criteria of an Administration may be accepted in lieu of Sections 5-12-4 and 5-12-5. Where the intact stability criteria are not applicable to a particular vessel, the review will be in accordance with other recognized criteria acceptable to ABS.

## 11 Onboard Computers for Stability Calculations

The use of onboard computers for stability calculations is not a requirement of class. However, if stability software is installed onboard fishing vessels contracted on or after 1 July 2005, it should cover all stability requirements applicable to the vessel and is to be approved by ABS for compliance with the requirements of Appendix 3-3-A2, “Onboard Computers for Stability Calculations”.

PART

5

CHAPTER 12 Fishing Vessels (2001)

SECTION 4 Intact Stability

1 Intact Stability – General (2014)

The intact stability of each fishing vessel is to be evaluated and the results for all loading conditions indicated in 5-12-4/9, verifying compliance with the intact stability criteria in 5-12-4/3, 5-12-4/5 and 5-12-4/7 and taking into account the design considerations indicated in 5-12-4/11, are to be submitted.

Where it may be critical, the longitudinal intact stability of the loading conditions is to be investigated.

The maximum allowable KG (or minimum required GM) curve shall confirm compliance with the intact criteria in 5-12-4/3, 5-12-4/5 and 5-12-4/7. This curve (or series of curves) shall cover the full range of operation (Load Line/maximum draft to arrival condition, 5-12-4/9.1.7, and the full range of anticipated trims). The supporting calculations for this curve shall be submitted for review.

Where it is desired to use intact stability criteria which differ from the following, special consideration may be given upon submission of the details and service experience.

3 Intact Stability Criteria

3.1 General

(2014) The intact stability of the fishing vessel is to meet the criteria in Part B Section 2.1.3.1 of the IMO Intact Stability Code, 2008, supplemented by a required 60 degree range of positive stability. This criterion is summarized below and illustrated in 5-12-4/Figure 1A.

3.1.1

The area under the righting arm curve is not to be less than 0.055 meter-radians (10.3 ft-degrees) up to an angle of heel of 30 degrees.

3.1.2

The area under the righting arm curve between the angles of heel of 30 degrees and 40 degrees or between 30 degrees and the angle of downflooding ( $\theta_p$ ), if downflooding occurs at less than 40 degrees, is not to be less than 0.030 meter-radians (5.6 ft-degrees)

3.1.3

The area under the righting arm curve is not to be less than 0.090 meter-radians (16.9 ft-degrees) up to an angle of heel of 40 degrees or the angle of downflooding ( $\theta_p$ ), if this angle is less than 40 degrees.

*Note:* This criterion requires that the sum of the area under the righting arm curve to 30 degrees and the righting arm curve between 30 degrees and 40 degrees or 30 degrees and the angle of downflooding be greater than 0.090 meter-radians (16.9 ft-degrees). This means that either or both of these areas is to be greater than that specified in 5-12-4/3.1.2 and 5-12-4/3.1.3.

3.1.4

The righting arm is to be at least 0.2 m (0.66 ft) at an angle greater than or equal to 30 degrees.

3.1.5

The maximum righting arm is to occur at an angle of heel preferably exceeding 30 degrees but not less than 25 degrees.

3.1.6 (2014)

Initial GM is not to be less than 0.35 m (1.15 ft). The required initial GM may be reduced to at least 0.15 m (0.5 ft) for vessels having a full length superstructure or for any vessel with a length of 70 m (229.7 ft.) or greater.

3.1.7 (2014)

A minimum range of stability of 60 degrees is to be provided.

3.1.8

For fishing vessels less than 24 m (79 ft), the criteria indicated above will be specially considered.

**FIGURE 1A**  
**Intact Stability Criteria for Fishing Vessels**

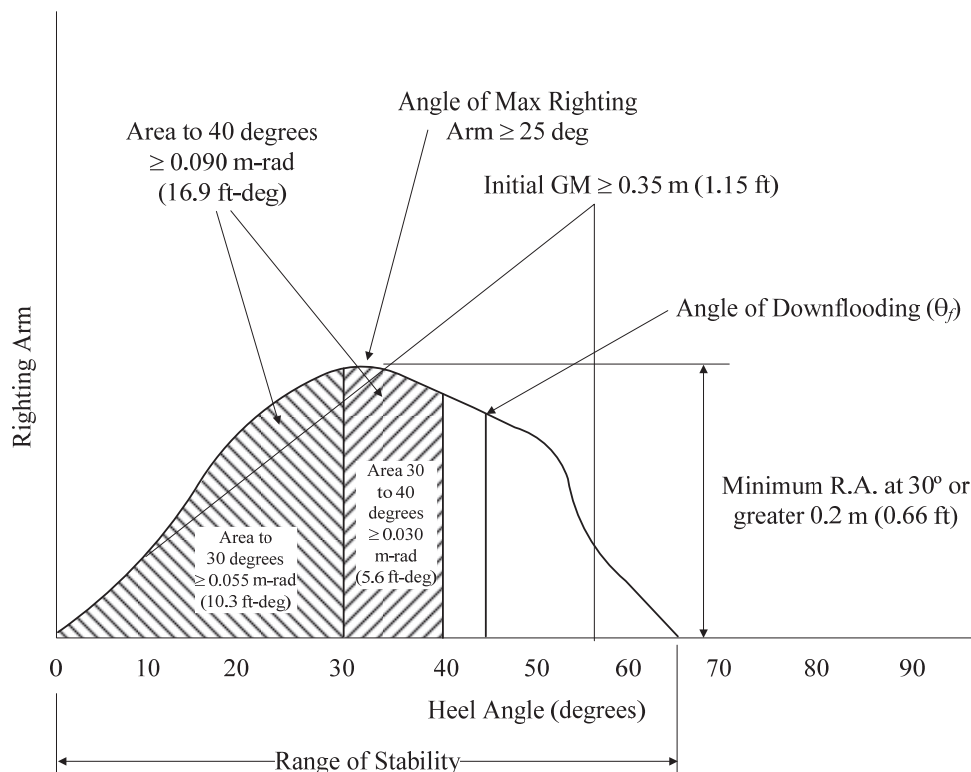

**3.3 Alternate Criteria**

Where the vessel's characteristics are such that the above criteria in 5-12-4/3.1 cannot be met, the following criteria may be used:

3.3.1

The area under the righting arm curve is not to be less than 0.070 meter-radians (13.1 ft-degrees) up to an angle of 15 degrees when the maximum righting arm occurs at 15 degrees, and 0.055 meter-radians (10.3 ft-degrees) up to an angle of 30 degrees when the maximum righting arm occurs at 30 degrees or above. Where the maximum righting arm occurs at angles of between 15 degrees and 30 degrees, the corresponding area under the righting arm curve is to be:

$$0.055 + 0.001 (30 - \theta_{\max}) \quad \text{meter-radians **}$$

$$10.3 + 0.187 (30 - \theta_{\max}) \quad \text{ft-degrees}$$

\*\*  $\theta_{\max}$  is the angle of heel in degrees at which the righting arm curve reaches its maximum.

3.3.2

The area under the righting arm curve between the angles of heel and 30 degrees and 40 degrees, or between 30 degrees and  $\theta_f$  if this angle is less than 40 degrees, is to be not less than 0.03 meter-radians (5.6 ft-degrees).

3.3.3

The righting arm is to be at least 0.2 m (0.66 ft) at an angle of heel equal to or greater than 30 degrees.

3.3.4

The maximum righting arm is to occur at an angle of heel not less than 15 degrees.

3.3.5 (2014)

The initial GM is to be not less than 0.35 m (1.15 ft). The required initial GM may be reduced to at least 0.15 m (0.5 ft) for vessels having a full length superstructure or for any vessel with a length of 70 m (229.7 ft.) or greater.

3.3.6 (2014)

A minimum range of stability of 60 degrees is to be provided.

3.3.7

For fishing vessels less than 24 m (79 ft), the criteria indicated above will be specially considered.

**FIGURE 1B**  
**Alternate Intact Stability Criteria for Fishing Vessels (2014)**

$$\text{Area } A_1 \geq \begin{cases} 0.07 \text{ m-rad (13.1 ft-deg), } \theta_{\max} \leq 15^\circ \\ 0.055 + 0.001(30 - \theta_{\max}) \text{ m-rad} \\ 10.3 + 0.187(30 - \theta_{\max}) \text{ ft-deg} \\ 0.55 \text{ m-rad (10.3 ft-deg), } \theta_{\max} \geq 30^\circ \end{cases} \quad 15^\circ < \theta_{\max} < 30^\circ$$

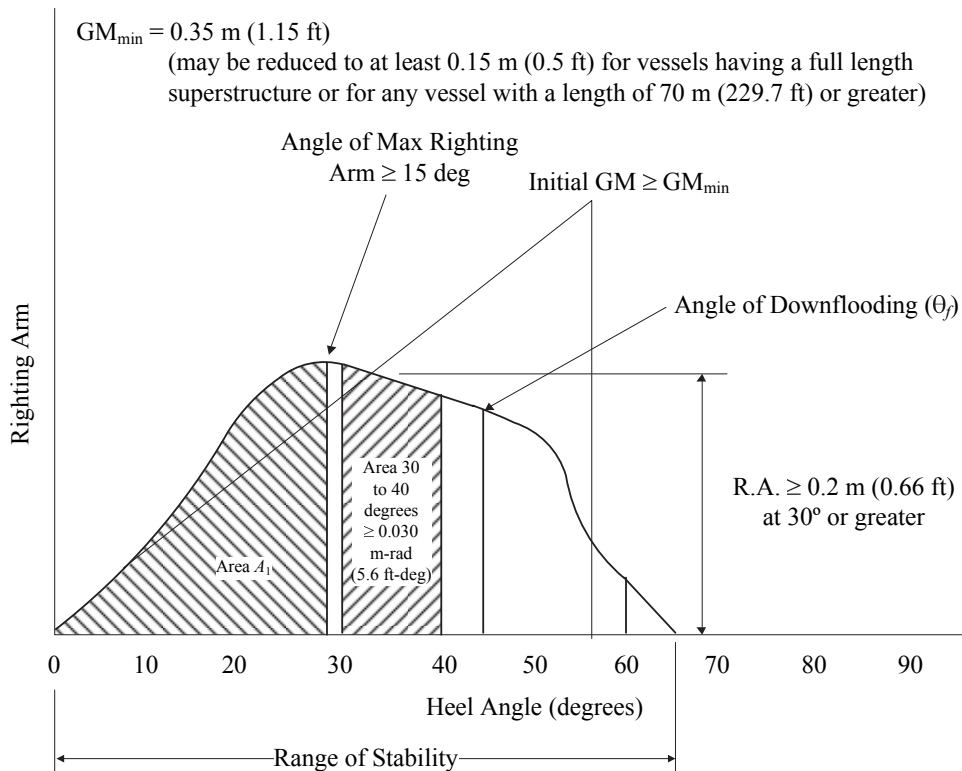

## 5 Severe Wind and Rolling Criteria

### 5.1 General

(2014) The fishing vessel is to meet the severe wind and rolling criteria, indicated in Part B Section 2.1.4 of the IMO Intact Stability Code, 2008, as summarized below and illustrated in 5-12-4/Figure 2.

#### 5.1.1 (2014)

The vessel is assumed to be subjected to a steady wind pressure acting perpendicular to the vessel's centerline which results in a steady wind heeling arm ( $L_{w1}$ ). The vessel heel to an angle of equilibrium ( $\theta_0$ ) is not to exceed 16 degrees or 80% of the angle of deck edge immersion, whichever is less.

#### 5.1.2

From the resultant angle of equilibrium ( $\theta_0$ ), the vessel is assumed to roll due to wave action to an angle of roll ( $\theta_1$ ) to windward.

#### 5.1.3

The vessel is then subjected to a gust wind pressure which results in a gust wind heeling arm ( $L_{w2}$ ).

#### 5.1.4

Under these circumstances, area "b" is to be equal to or greater than area "a".

#### 5.1.5

Free surface effects are to be accounted for in the standard conditions of loading, as discussed in 5-12-4/9.

#### 5.1.6

The angles in 5-12-4/Figure 2 are defined as follows:

- $\theta_0$  = angle of heel under action of steady wind (i.e., the intersection of the wind heeling arm curve,  $L_{w1}$ , and the righting arm curve)
- $\theta_1$  = angle of roll to windward due to wave action
- $\theta_2$  = angle of downflooding ( $\theta_p$ ) or 50 degrees or  $\theta_{c2}$ , whichever is less
- $\theta_3$  = angle of heel at which openings in the hull, superstructures or deckhouses which cannot be closed weathertight immerse. In applying this criterion, small openings through which progressive flooding cannot take place need not be considered as open
- $\theta_{c1}$  = angle of first intercept of wind heeling arm curve,  $L_{w2}$ , and righting arm curve
- $\theta_{c2}$  = angle of second intercept of wind heeling arm curve,  $L_{w2}$ , and righting arm curve

#### 5.1.7 (2014)

The wind heeling arms  $L_{w1}$  and  $L_{w2}$ , referred to above, are constant values at all angles of inclination and are to be calculated as shown below:

$$L_{w1} = \frac{PAZ}{\Delta} \quad \text{m (ft)}$$

$$L_{w2} = 1.5 L_{w1} \quad \text{m (ft)}$$

where

$P = 0.0514 \text{ t/m}^2$  (0.0047 lt/ft<sup>2</sup>) for vessels 45 m (147.6 ft.) in length and over  
 For vessels between 24.0 m (79 ft.) and 45 m (147.6 ft.) in length, the values of  $P$  shall be taken from the following table:

$h$ (m)	1	2	3	4	5	6 and up
$p$ (t/m <sup>2</sup> )	0.0322	0.0394	0.0438	0.0469	0.0494	0.0514
$p$ (LT/ft <sup>2</sup> )	0.00294	0.00360	0.00400	0.00428	0.00452	0.00470

$A =$  projected lateral area of the portion of the vessel and deck cargo above the waterline, m<sup>2</sup> (ft<sup>2</sup>)  
 $Z =$  vertical distance from the center of  $A$  to the center of the underwater lateral area or approximately to a point at one half the draft, m (ft)  
 $h =$  vertical distance from the center of the projected lateral area of the vessel above the waterline to the waterline, m (ft)  
 $\Delta =$  displacement, metric tons (long tons)

5.1.8 (2014)

The angle of roll ( $\theta_1$ ) is to be calculated as follows:

$$\theta_1 = 109k X_1 X_2 \sqrt{rs} \text{ degrees}$$

where

$X_1 =$  factor as shown in 5-12-4/Table 1  
 $X_2 =$  factor as shown in 5-12-4/Table 2  
 $k =$  factor as follows:  
 = 1.0 for round bilge vessel having no bilge or bar keels  
 = 0.7 for a vessel having sharp bilges  
 = as shown in 5-12-4/Table 3 for a vessel having bilge keels, a bar keel or both  
 $r = 0.73 + 0.6 OG/d$

with

$OG =$  distance between the center of gravity and waterline, m (ft) (+ if center of gravity is above the waterline, – if it is below)  
 $d =$  mean design draft of the vessel, m (ft)  
 $s =$  factor as shown in 5-12-4/Table 4.

$$\text{Rolling Period } T = \frac{2.0CB}{\sqrt{GM}} \text{ sec. (SI/MKS units)}$$

$$T = \frac{1.108CB}{\sqrt{GM}} \text{ sec. (U.S. units)}$$

where

$C = 0.373 + 0.023 (B/d) - 0.043(L/100)$  (SI/MKS units)  
 $C = 0.373 + 0.023 (B/d) - 0.000131L$  (U.S. units)

The symbols in 5-12-4/Table 1 to 5-12-4/Table 4 and formula for the rolling period are defined as follows:

- $L$  = waterline length of the vessel, m (ft)
- $B$  = molded breadth amidships of the vessel, m (ft)
- $d$  = mean design draft of the vessel, m (ft)
- $C_b$  = block coefficient
- $A_k$  = total overall area of bilge keels, or area of the lateral projection of the bar keel, or sum of these areas,  $m^2$  ( $ft^2$ )
- $GM$  = metacentric height corrected for free surface effect, m (ft)

The angle of roll for vessels provided with active anti-rolling devices is to be determined without taking into account the operation of these devices. For vessels with anti-roll tanks, the full free surface effect of the tanks is to be used to determine the GM value used in calculating the angle of roll.

**FIGURE 2**  
**Severe Wind and Rolling Criteria**

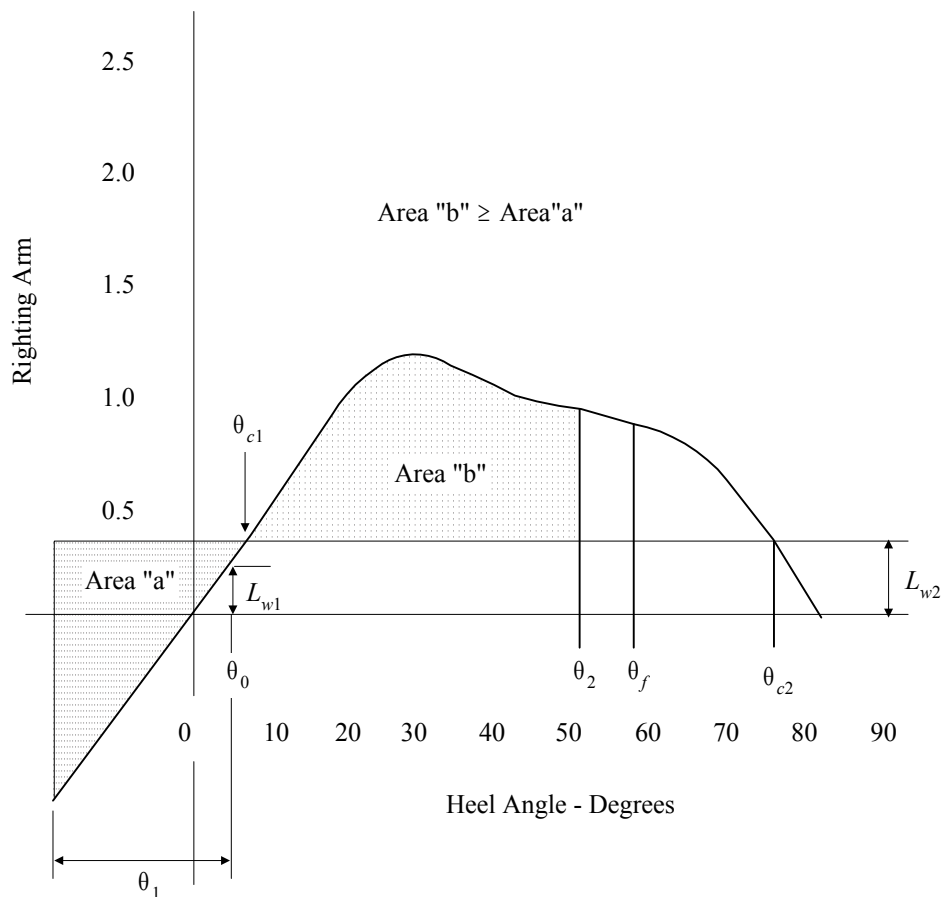



**TABLE 1**  
**Values of Factor  $X_1$**

$B/d$	$X_1$
$\leq 2.4$	1.00
2.5	0.98
2.6	0.96
2.7	0.95
2.8	0.93
2.9	0.91
3.0	0.90
3.1	0.88
3.2	0.86
3.3	0.84
3.4	0.82
$\geq 3.5$	0.80

**TABLE 2**  
**Values of Factor  $X_2$**

$C_b$	$X_2$
$\leq 0.45$	0.75
0.50	0.82
0.55	0.89
0.60	0.95
0.65	0.97
$\geq 0.70$	1.00

**TABLE 3**  
**Values of Factor  $k$  (2014)**

$\frac{Ak100}{LB}$	$k$
0.0	1.00
1.0	0.98
1.5	0.95
2.0	0.88
2.5	0.79
3.0	0.74
3.5	0.72
$\geq 4.0$	0.70

**TABLE 4**  
**Values of Factor  $s$  (2014)**

$T$	$s$
$\leq 6$	0.100
7	0.098
8	0.093
12	0.065
14	0.053
16	0.044
18	0.038
$\geq 20$	0.035

(Intermediate values in 5-12-4/Table 1 through 5-12-4/Table 4 should be obtained by linear interpolation.)

## 7 Treatment of Lifting Weights and Heeling Moments Due to Fishing Gear (2014)

### 7.1 General

When a weight is lifted from the deck or a fishing net filled with fish is lifted from the water, the weight then acts at the tip of the boom and is to be considered in developing the VCG and the righting arm curves.

The stability information shall contain the details of the lifting gear including the maximum heeling moments and other information for the crew to avoid exceeding the allowable lifting loads and/or heeling moments used in the stability calculations.

### 7.3 Definitions

As used in this section:

- i) Hook load means the weight of the object (i.e., fishing net with catch, crab pot, etc.) lifted by the crane.
- ii) Crane radius means the distance illustrated in 5-12-4/Figure 3.

- iii) Crane Heeling Moment is the maximum heeling moment developed by multiplying the weight of the hook load and boom by the horizontal distance from vessel's centerline to the hook load and boom center of gravity, respectively, considering the full range of crane elevations and weights. The resulting heeling moment is to be converted to a heeling arm at zero degrees by dividing it by the vessel displacement. The heeling arm is to be assumed constant for all heel angles.  
  
If multiple cranes are used simultaneously, the Crane Heeling Moment shall include the maximum heeling moment created by each crane.
- iv) The equilibrium heel angle is the angle of heel under the combined effects of the hook load, counter-ballasting and a beam wind.

**FIGURE 3**  
**Crane Radius (2014)**

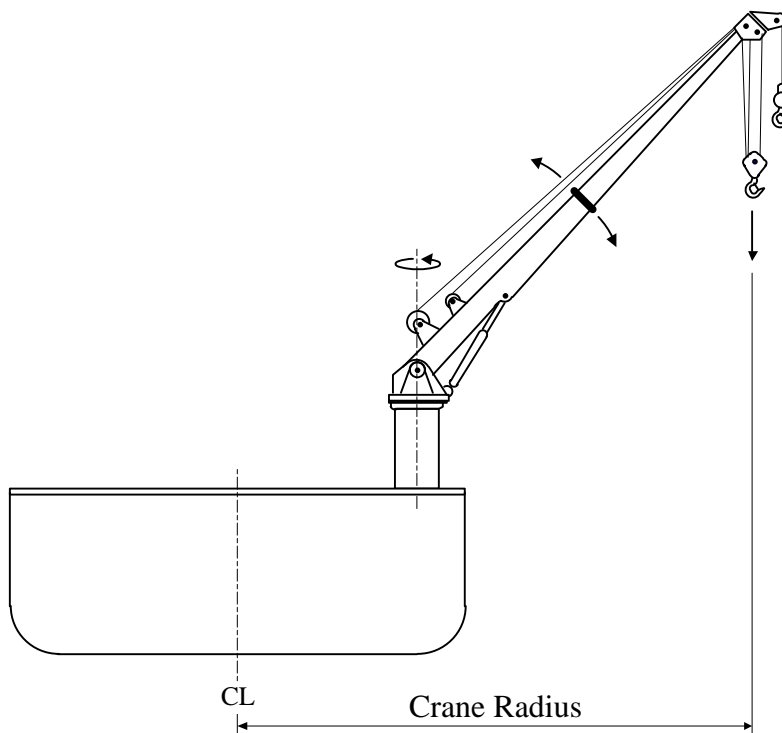

## 7.5 Heeling Moment Due to Onboard Crane Use

### 7.5.1

The stability of each vessel that uses onboard crane(s) for fishing operations shall be evaluated for the effects of the heeling moments. Stability calculations are to include the following considerations when showing compliance with the requirements in 5-12-4/7.5.2:

- i) Crane Heeling Moment, and
- ii) The effect of beam wind on the projected area of the vessel (including deck cargo) should be evaluated for 25.7 m/s (50 kn) wind speed. Should a lesser wind speed be used, that wind speed shall be listed in the trim and stability booklet as an operational restriction during lifting operations.

The heeling arm, which shall remain constant for all heel angles, shall be calculated as:

$$HA = (P \times A \times H) / \Delta$$

where

- $A$  = projected lateral area, in square meters (square feet), of all exposed surfaces (including deck cargo), in the upright condition
- $H$  = vertical distance, in meters (feet), from the center of  $A$  to the center of the underwater lateral area or approximately to the one-half draft point.
- $\Delta$  = displacement of the vessel with the hook load included, in metric tons (long tons)
- $P$  = wind pressure, calculated as:  
 $= f V_k^2 C_h C_s$  N/m<sup>2</sup> (kgf/m<sup>2</sup>, lbf/ft<sup>2</sup>)
- $f$  = 0.611 (0.0623, 0.00338)
- $V_k$  = wind velocity in m/s (m/s, kn)
- $C_s$  = 1.0, shape coefficient
- $C_h$  = height coefficient from 5-12-4/Table 5

**TABLE 5**  
**Values of  $C_h$  (2014)**

<i>H (Meters)</i>	<i>H (Feet)</i>	$C_h$
0.0–15.3	0–50	1.00
15.3–30.5	50–100	1.10
30.5–46.0	100–150	1.20
46.0–61.0	150–200	1.30
61.0–76.0	200–250	1.37
76.0–91.5	250–300	1.43
91.5 and above	300 and above	1.48

### 7.5.2

As illustrated in 5-12-4/Figure 4, each vessel must have a righting arm curve with the following characteristics:

- i)* The area under the righting arm curve from the equilibrium heel angle up to the smallest of the following angles must be at least 0.080 meter-radians (15 foot-degrees):
  - a)* The downflooding angle
  - b)* 40 degrees
- ii)* The deck edge should not be submerged at the equilibrium heel angle.
- iii)* The equilibrium heel angle shall not exceed 10 degrees.

**FIGURE 4**  
**Lifting Criteria (2014)**

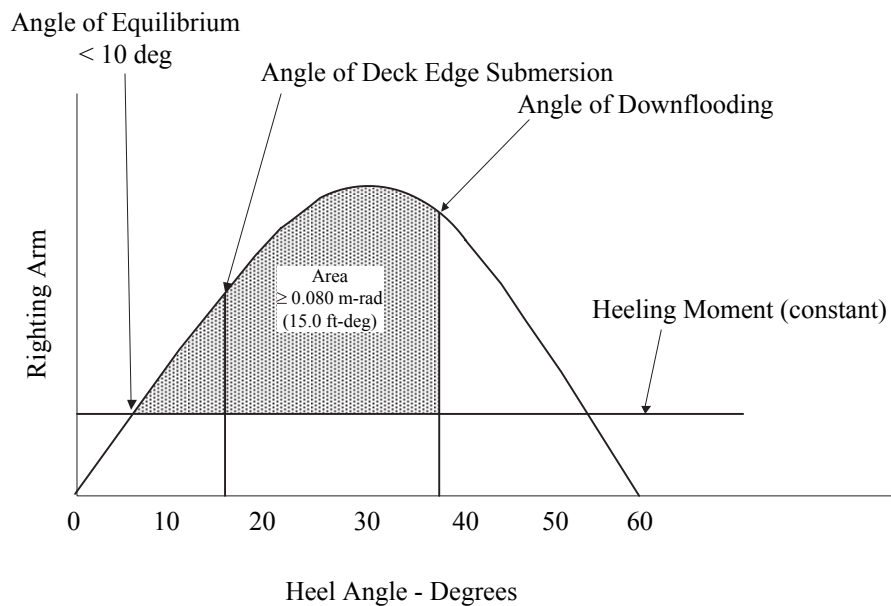

## 7.7 Heeling Moment Due to Fishing Gear

### 7.7.1

The expected maximum heeling moments imposed by trawling or seining, for instance, are to be evaluated by the designer and included in the stability analysis.

### 7.7.2

The effect of a trawl snagging on the bottom (and the vessel's attempt to clear the snag) is to be considered. When the trawl becomes snagged the potential heeling moment can exceed the righting moment. 5-12-4/Figure 5 shows a family of heeling moment curves for a given propeller thrust and vessel trawl geometry imposed on a righting arm curve. The illustration is not intended to be numerically specific, but is instead presented to show how operational practices must be considered in developing stability information. The heeling moment increases for decreasing trawl angles  $a$ , where  $a$  is the angle which the trawl wire makes with the vertical. The magnitude of the heeling moment is a function of the trawl angle, which is in turn a function of the wire length and the water depth. Since normal practice is to shorten up the trawl wire and use power to break the trawl free, the angle at which the wire trails can be significantly reduced as the vessel moves towards the location of the snag. The stability information should warn the operators that attempting to release a fastened trawl by rapidly increasing the engine thrust or suddenly increasing the power on the winch may cause the vessel to capsize. Consideration should be given to the need for quick-release devices on winches and other lifting equipment.

**FIGURE 5**  
**Calculating the Effect of a Fastened Trawl**

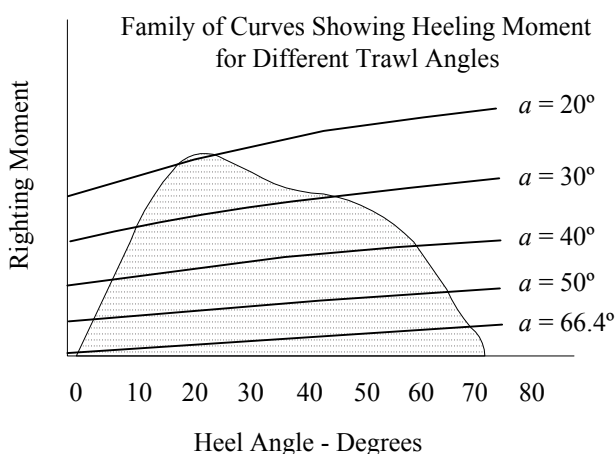
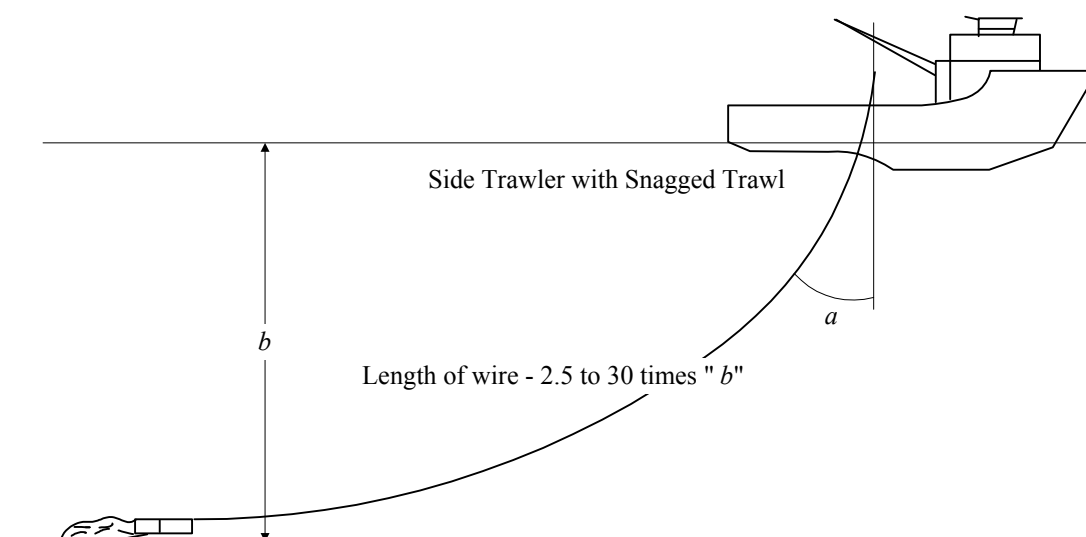

## 9 Standard Loading Conditions

### 9.1 Loading Conditions

The following assumed loading conditions, as a minimum, are to be investigated on each fishing vessel:

#### 9.1.1 (2014)

Departure condition from port with full fuel, water, stores, ice, fishing gear (including pot load or other gear on deck), etc.

#### 9.1.2 (2014)

Arrival at the fishing grounds with reduced fuel, water and stores, ice, fishing gear (including pot load or other gear on deck). and no catch (the amount of fuel, water and stores based on the distance to the fishing area).

#### 9.1.3 (2014)

At the fishing grounds with 50 percent fuel, water and stores, cargo holds empty and either the maximum deck load on deck or the holds 50 percent full, whichever is consistent with the vessel's fishing method).

- 9.1.4 Departure from the fishing grounds with reduced fuel, water, and stores and full catch.
- 9.1.5 (2014)  
Departure from the fishing grounds with reduced fuel, water, and stores and 20 percent of full catch.
- 9.1.6 Arrival at home port with 10 percent fuel, water and stores, and full catch including any weights to be lifted or suspended and their effects on stability.
- 9.1.7 Arrival at home port with 10 percent fuel, water, and stores and 20 percent of full catch.
- 9.1.8 Other loading conditions in which the vessel may be operated, such as other partial catch and tank loading combinations, with deck loads, using boxes to store fish, while lifting, in ballast and during periods of icing.

### 9.3 Load Considerations

The following considerations are to be included in assessing loading conditions.

- 9.3.1 In addition to the loading conditions noted above, loading conditions are to be calculated for any other unusual loads or operating practices not considered by the criteria which may have an effect on the vessel being designed.
- 9.3.2 Operating conditions which may seriously impair the stability of the vessel should be brought to the attention of the operator and recommended practical corrective measures are to be included in the stability information furnished to the operator.
- 9.3.3 When calculating operating conditions, the weight of all fishing gear on deck in that condition (i.e., wet nets, tackle, pots, traps, etc.) is to be included.
- 9.3.4 (2014)  
If the vessel operates in areas where ice accretion is likely to occur, the icing loads in 5-12-4/11.11 shall be included.
- 9.3.5 The cargo may be assumed to be homogeneous unless this is inconsistent with practice.
- 9.3.6 Deck cargo is to be included.
- 9.3.7 (2014)  
The free surface of slack ballast tanks or fish wells is to be accounted for if it is present in normal operations.
- 9.3.8 If normal practice is to stow fish so that one end of the hold is loaded higher, then the increase in VCG is to be accounted for.

## 11 Design and Operating Factors Affecting Stability

The following design considerations, environmental forces and operating conditions which affect the stability of each fishing vessel are to be considered when developing the stability calculations and appropriate instructions are to be included in the stability information furnished to the master.

### 11.1 Lightship and the Inclining Experiment (2014)

#### 11.1.1

Upon completion, each vessel is to undergo an inclining experiment to determine the actual displacement and position of the center of gravity for the lightship condition. The inclining experiment is to be conducted in accordance with Part B Chapter 8 of the 2008 Intact Stability Code and ASTM Standard F-1321-90, "*Standard Guide for Conducting a Stability Test (Lightweight Survey and Inclining Experiment) to Determine the Light Ship Displacement and Centers of Gravity of a Vessel*"

#### 11.1.2

If the inclining experiment results on the initial vessel in a series have been approved, the inclining experiment required by 5-12-4/11.1 may be waived provided that, for each sister vessel (built to the same plans in the same shipyard), the weights and centers of any known differences are documented and a lightweight survey is conducted to confirm the effects of the differences on the lightship characteristics.

#### 11.1.3

If it can be demonstrated that the performance of an inclining experiment is not practicable or safe or yields inaccurate results due to the specific proportions, arrangements, strength or hull of a ship, the vessel's lightship characteristics may be determined by a detailed weight estimate confirmed by a lightweight survey. A formal request for an inclining experiment waiver shall be made to ABS technical office and shall include the technical justification for the request.

#### 11.1.4

Prior to the performance of each inclining experiment or lightweight survey, a test procedure shall be submitted for approval. The procedure shall include the following data, as applicable:

- Identification of the vessel to be inclined
- Date and location of the experiment
- Inclining weight data
- Pendulum locations and lengths. Alternate measuring devices may be proposed for use.
- Approximate draft and trim of the vessel, including location of draft and freeboard readings
- Condition/loading of each tank
- Estimated items to be installed, removed, or relocated after the experiment, including the weight and location of each item
- Schedule of events
- Details of weight movements
- Person or persons responsible for conducting the experiment

#### 11.1.5

Each inclining experiment and lightweight survey must be performed in the presence of an ABS Surveyor and in accordance with the approved experiment procedure. The responsibility for preparing the vessel for the test and conducting the test rests with the owner, shipbuilder or naval architect. The Surveyor will verify all of the data and will assist only as necessary to obtain valid test results. Where the inclining experiment is conducted by flag State Administrations, the Surveyor is to witness the inclining experiment.

11.1.6

For vessels undergoing modifications, the lightship values may be approved without conducting a lightweight survey or inclining experiment if the submitted detailed weight calculation shows a change in both lightship weight and LCG of less than shown below.

- i) Lightship LCG, relative to the most recent approved lightship data, is not to exceed 0.5% of  $L_s^*$ , and

Lightship displacement, corrected for any known differences relative to the inclined vessel, is not to exceed:

For $L \leq 50$ m	2% of the lightship displacement from the most recent approved lightship data
For $L \geq 160$ m	1% of the lightship displacement from the most recent approved lightship data
For intermediate length	By linear interpolation.

- ii) Where a ship is within these limits, the calculated values of lightweight, lightship LCG and lightship VCG should be used in all subsequent stability information supplied to the Master.
- iii) Where a ship is outside of either of these limits, an inclining experiment is to be performed to determine the new lightship values that will be used in all subsequent stability information supplied to the Master.

\* Note:  $L_s$  is the greatest projected molded length of that part of the ship, at or below decks limiting the vertical extent of flooding with the ship, at the deepest subdivision draft.

**11.3 Calculation of Righting Arms (2014)**

11.3.1

The hull designs of fishing vessels, with house forward and working areas aft, generally cause the vessel to change draft and trim significantly as it is heeled. When calculating the loading conditions, the righting arms are to be determined assuming the initial trim and using constant trimming moments (free to trim).

11.3.2

Superstructures and deck houses may be included in the buoyant volume if the structure is weathertight and of sufficient strength, and if all openings in the sides and ends are weathertight, and all portlights and windows, including those fitted in doors, have deadlight covers.

11.3.3

Stern ramps are to be deducted from the buoyant volume.

11.3.4

Bulwarks are not to be included in the buoyant volume.

**11.5 Free Surface Effects**

The free surface effect is a major consideration for many fishing vessels. Because of this, the following is recommended to account for the free surface effect:

11.5.1

For all conditions, the initial metacentric height and righting arm curves are to be corrected for the effect of free surfaces of liquids in tanks by calculating the following:

11.5.1(a) For each type of consumable liquid, the free surface effect of at least one transverse pair of wing tanks or a single centerline tank having the greatest free surface effect.



11.5.1(b) (2014) The free surface effect of each partially filled tank containing other than consumable liquids. If the level of the tank is constant throughout the voyage, the actual free surface may be used. If the tank level changes, the maximum free surface in the range of fill levels shall be used.

11.5.1(c) (2014) The maximum free surface effect of passive roll stabilization tanks.

#### 11.5.2

Either the standard free surface calculation, based on the moment of inertia of the tank, or the moment of transference method may be used.

#### 11.5.3

Because of the large free surface moment, vessels with large fish wells are to maintain these wells in either empty or fully pressed up condition. A check of the transition period at sea is to be completed if ballasting at sea is the practice of the operator.

#### 11.5.4

The free surface correction for pairs of tanks fitted with cross connection piping but without valves such as passive roll stabilization tanks are to be calculated assuming the tanks are one common tank.

### 11.7 Ballast

#### 11.7.1

Ballast is normally used to improve the stability of the vessel. However, depending on the location of the ballast, it can either raise or lower the center of gravity of a vessel. Ballast may also decrease the reserve buoyancy of a given vessel and can adversely change the trim of the vessel.

#### 11.7.2

If it is the intent to ballast during ballast operations the free surface effect will exist during the interim period until the ballast tank is pressed up is to be considered in developing the stability data.

#### 11.7.3 (2014)

The installation of permanent ballast is to be verified by the attending Surveyor. Permanent ballast is not to be removed without notifying ABS and evaluating the effect on stability.

### 11.9 Watertight Integrity and Flooding

#### 11.9.1

The importance of providing watertight closures that can be quickly closed and easily maintained is to be considered in developing a hull which can meet or exceed the stability criteria and provide an efficient fishing platform.

#### 11.9.2

All closures which must be opened at sea are to be kept as far inboard and as high as possible in order to maximize the angle at which downflooding occurs. Doors in forecastle, poop, and deckhouse end bulkheads are often located near the side of the vessel and could be immersed at low angle of heel. Wherever possible these closures are to be kept close to the centerline, then the angle of downflooding is considerably increased with a resultant increase in safety.

#### 11.9.3 (2014)

Instructions to the master are to be provided to keep all watertight closures closed except when actually being used. These closures should be clearly labeled "This opening is to be kept closed except when actually being used." or similar. A diagram showing the location to all watertight closures is to be placed aboard the vessel in the Stability Information provided to the operator. An example of this is shown in 5-12-4/Figure 6.

**FIGURE 6**  
**Diagram of Key Watertight Closures**

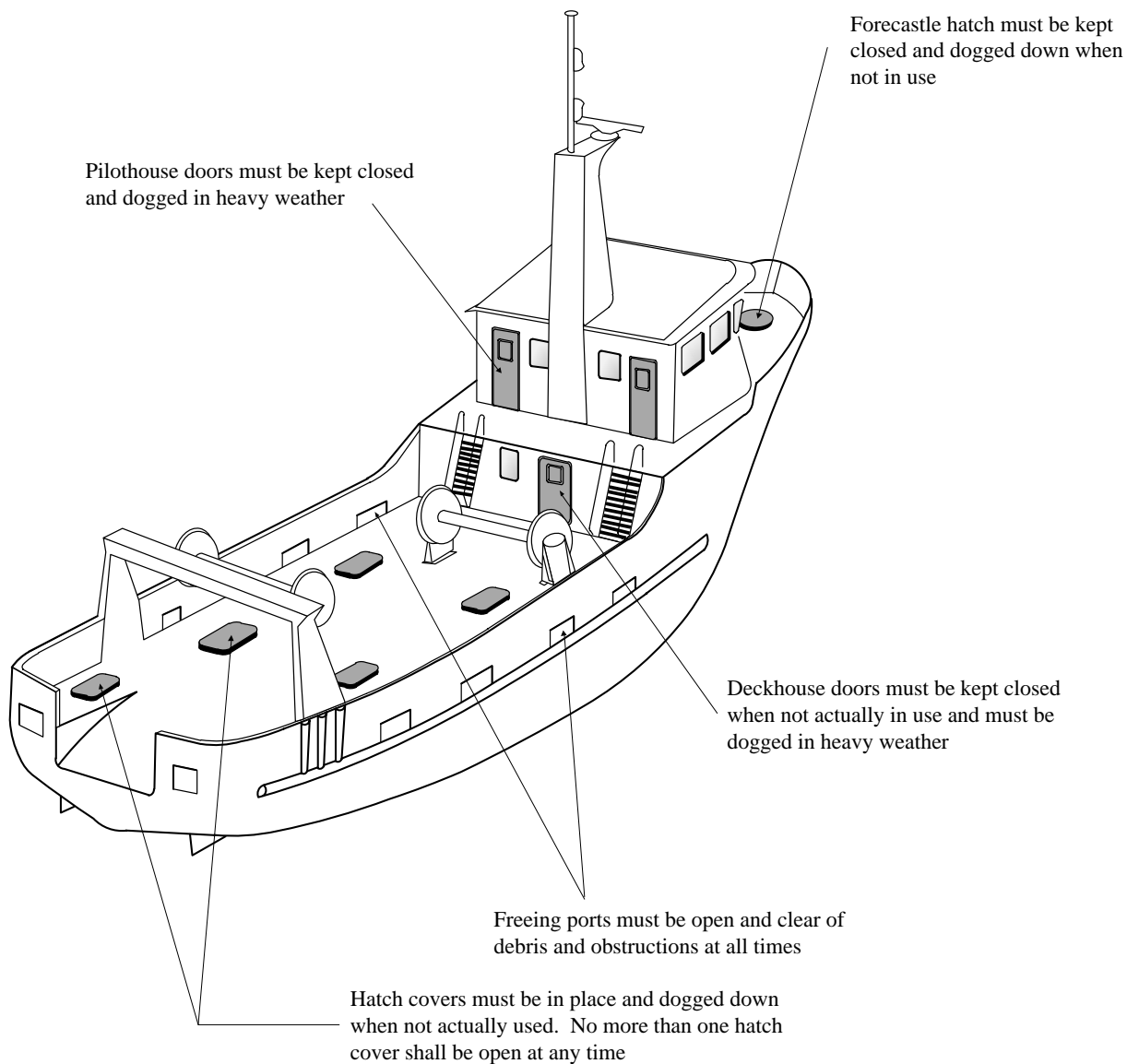

## 11.11 Icing (2014)

### 11.11.1

If the vessel operates in areas where ice accretion is likely to occur, the vessel's conditions of loading given in 5-12-4/9 shall include the icing allowance in either 5-12-4/11.11.2 or 5-12-4/11.11.3 when they are evaluated for compliance with the applicable intact and damage stability requirements.

### 11.11.2

The minimum weights of ice are:

- i) The weight of ice on all horizontal surfaces is to be at least  $30 \text{ kg/m}^2$  ( $6.14 \text{ lbs/ft}^2$ ).
- ii) The weight of ice of the projected vertical area above the waterline is to be at least  $15 \text{ kg/m}^2$  ( $3.07 \text{ lbs/ft}^2$ ). This accounts for  $7.5 \text{ kg/m}^2$  ( $1.54 \text{ lbs/ft}^2$ ) on both the port and starboard vertical surfaces.

Plans showing projected horizontal and vertical areas are to be submitted.

11.11.3

The weight of ice recommended by the Administration where the vessel is intended to operate (such as the Transport Canada – Marine Safety requirements for vessels operating in their waters), may be substituted for 5-12-4/11.11.2.

11.11.4

The height of the center of gravity of the accumulated ice is to be located according to the position of the corresponding horizontal surfaces (decks and gangways) and other continuous surfaces on which ice can reasonably expected to accumulate. The projected lateral area of small discontinuous surfaces such as rails, spars, and rigging with no sails can be accounted for by increasing the calculated area by 5 percent and the static moments of the area by 10 percent.

### 11.13 Water on Deck

The IMO Guidance as a means of evaluating the residual stability of the vessel with water on deck is repeated below.

11.13.1

The ability of the vessel to withstand the heeling effect due to the presence of water on deck is to be demonstrated by showing that with the vessel in the worst operating condition, the ratio of area “b” to area “a” shown in 5-12-4/Figure 7 is not to be less than 1.0. That is, it satisfies the following equation in the worst operating condition:

$$C_{wod} = \frac{\text{area "b"}}{\text{area "a"}} \geq 1.0$$

11.13.2

The angle which limits area “b” is to be equal to the downflooding angle  $\theta_f$  or 40 degrees, whichever is less.

11.13.3 (2014)

The value of the heeling moment  $M_{wod}$  (or the corresponding heeling arm) due to the presence of water on deck is to be determined assuming that the deck well is filled to the top of the bulwark at its lowest point and the vessel heeled up to the angle at which this point is immersed (see 5-12-4/Figure 8). For the determination of  $M_{wod}$  the following formula should be used:

$$M_{wod} = K M_w$$

where

$M_w$  = static heeling moment due to water on deck

$K$  = coefficient

- a) If  $M_{wod}$  is determined by static approach,  $K = 1.0$  may be applied.
- b) If  $M_{wod}$  is determined by quasi-static approach,  $K$  may take into account the rolling period of the vessel and the dynamic effect of the water flow, including the effect of the disposition and configuration of the deck wells and deckhouses. The value of  $K$  should be satisfactory, taking into account the type of vessel, area of operation, etc. For vessels where the angle of deck edge immersion  $\theta_D$  is less than  $10^\circ$  to  $15^\circ$ , or the angle of bulwark top immersion  $\theta_B$  is less than  $20^\circ$  to  $25^\circ$ , a value for  $K$  greater than 1.0 may be applied. When  $\theta_D$  is greater than  $20^\circ$  or  $\theta_B$  is greater than  $30^\circ$ , a value for  $K$  less than 1.0 may be applied.

11.13.4

When calculating  $M_{wod}$  the following assumptions are to be made:

- i) At the beginning the vessel is in upright position;
- ii) During heeling, trim and displacement are constant and equal to the values for the vessel without water on deck;
- iii) The effect of freeing ports should be ignored.

11.13.5

The above provisions may be adjusted, taking into account the seasonal weather conditions and sea states in the areas in which the vessels will operate, the type of vessel and its mode of operation.

11.13.6

Other methods for the calculation of the effect of water on deck using the dynamic approach may be adopted.

**FIGURE 7**  
**Method of Treatment of Water on Deck (2014)**

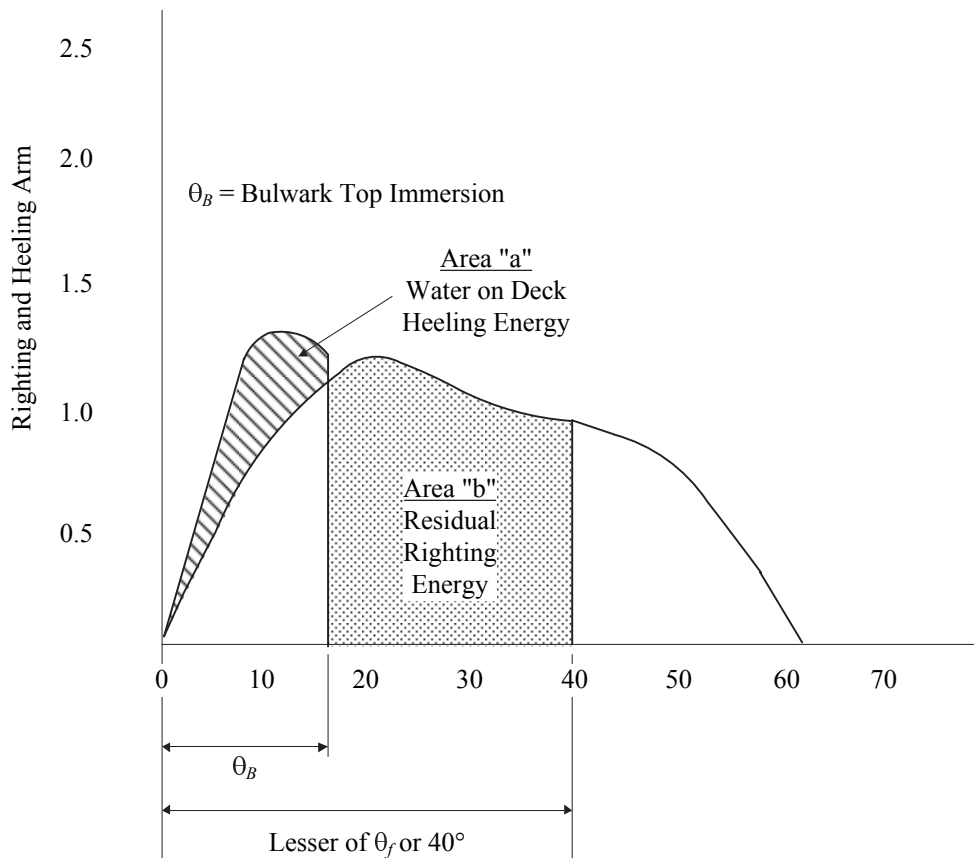

**FIGURE 8**  
**Volume of Water to be Included in Calculating Effect of Water on Deck (2014)**

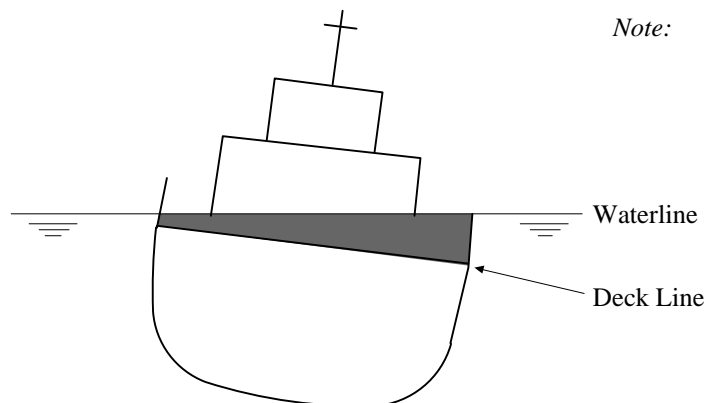

*Note:* Deck is filled to top of bulwark and bulwark is immersed.

### 13 Stability Guidance for the Master (2014)

#### 13.1

Each vessel is to be provided with stability information in a format acceptable to ABS. The format may be pictorial, tabular, simplified trim and stability booklet or other format that will provide a rapid means for the crew to evaluate the stability of the vessel.

#### 13.3

Each trim and stability book is to contain sufficient information to enable the Master to operate the vessel in compliance with the applicable intact and damage stability requirements in Section 5-12-5. Information on loading restrictions used to determine compliance with applicable intact and damage stability criteria is to encompass the entire range of operating drafts and the entire range of the operating trims.

The format of the trim and stability booklet and the information included will vary based on the vessel type and operation. Units of measure used in the trim and stability booklet are to agree with the units of measure of the draft markings.

##### 13.3.1

The following information shall be included in the trim and stability booklet:

- A table of contents and index for the booklet. All pages are to be numbered.
- A general description of the vessel, including identification, lightship data, amount and location of fixed ballast, vessel principal dimensions, Load Line draft, freeboard and allowances, maximum displacement and deadweight, etc.
- A brief description of the stability criteria satisfied including assumptions made in the calculations
- Instructions on the use of the booklet
- General arrangement plans showing watertight compartments, closures, vents, down-flooding angles, and allowable deck loadings
- Hydrostatic curves or tables
- Cross Curves of stability
- Capacity plan showing capacities and vertical, longitudinal, and transverse centers of gravity of stowage spaces and tanks

- Tank sounding/ullage tables showing capacities, vertical centers of gravity, longitudinal centers of gravity and free surface data in graduated intervals for each tank. This may be submitted as a separate document.
- Information on loading restrictions, such as cargo hold loading, live catch tanks, crab pot loads and stack heights, etc.
- A maximum KG or minimum GM curve that can be used to determine compliance with the applicable intact and damage stability criteria in Sections 5-12-4 and 5-12-5. This curve shall cover the full range of operation (Load Line draft to arrival condition (5-12-4/9.1.7) and the full range of operational trims).
- In addition to the standard loading conditions in 5-12-4/7, loading conditions showing vessel specific operations (lifting, towing, etc.) also are to be included.
- A rapid and simple means for evaluating the trim and stability of other loading conditions. This should include clear, step by step instructions for the calculation and evaluation of the loading condition, blank loading forms, and a worked example.
- General precautions for preventing unintentional flooding
- References to the Damage Control Booklet and/or Cargo Securing Manual, as applicable
- Any other necessary guidance for the safe operation of the vessel under normal and emergency conditions (i.e., required liquid ballast, fuel burn-off sequence, maximum cargo height, crane loads, etc.).
- The inclining experiment report may be included as an appendix.

#### 13.3.2

Intact and damage stability calculations supporting the maximum KG or minimum GM curve should be contained in a separate document and not included in the trim and stability booklet.

#### 13.3.3

The content and format of a simplified trim and stability booklet or simplified operating guidance shall cover the full operating envelope of the vessel and provide the Master with a rapid and simple means to evaluate the stability of the vessel. The format of the guidance (i.e., tank limitations, load restrictions, lifting restrictions, etc.) will be reviewed and accepted by ABS of a case-by-case basis.

## PART

# 5

## CHAPTER 12 Fishing Vessels (2001)

### SECTION 5 Damage Stability (2014)

#### 1 Applicability

Vessels 90m in Length and over, shall comply with the requirements of the *ABS Rules for Building and Classing Steel Vessels*. See also 5-12-1/3. Vessels of 100 m (328 ft) or greater in length and where the total number of persons onboard is 100 or more, shall be capable of remaining afloat with positive stability, after flooding of any one compartment assumed damaged.

#### 3 General

Taking into account, as initial conditions before flooding, all of the standard loading conditions (without icing) as referred to in 5-12-4/9 and the damage assumptions in 5-12-5/5, the vessel is to comply with the damage stability criteria as specified in 5-12-5/7.

The maximum allowable KG (or minimum required GM curve) in the trim and stability booklet shall confirm compliance with the damage criteria in 5-12-4/7. This curve (or series of curves) shall cover the full range of operation (Load Line draft to arrival condition, 5-12-4/9.1.7) and the full range of operational trims. The supporting calculations for this curve shall be submitted.

#### 5 Damage Assumptions

The following damage assumptions are to be applied:

- i) Damage is to be assumed to occur anywhere in the vessel's length between transverse watertight bulkheads. The longitudinal extent of damage is:  $(1/3)L_f^{2/3}$  m, where  $L_f$  is the freeboard length, as defined in 3-1-1/3.3.
- ii) The vertical extent of damage is to be assumed from the base line upwards without limit.
- iii) The transverse extent of damage is to be assumed as  $B/5$  m, measured inboard from the side of the vessel perpendicularly to the centerline at the level of the summer load line.

*Notes:*

1. The flooding should be restricted to any single compartment between adjacent transverse bulkheads. If there are steps or recesses in a transverse bulkhead of not more than 3.05 m (10 ft) in length located within the transverse extent of assumed damage, such transverse bulkhead may be considered intact and the adjacent compartments may be flooded singly. Where the step or recess within the transverse extent of damage exceeds 3.05 (10 ft) m in length in a transverse bulkhead, the two compartments adjacent to this bulkhead should be considered as flooded. The step formed at the junction of the aftpeak bulkhead and the afterpeak tank top should not be considered as a step.
2. If pipes, ducts or tunnels are situated within the assumed extents of damage, arrangements are to be made to ensure that progressive flooding cannot thereby extend to compartments other than those assumed to be floodable for each case of damage.
3. If damage of a lesser extent than that specified in 5-12-5/5i), 5-12-5/5ii) and 5-12-5/5iii) results in a more severe condition, such lesser extent is to be assumed.
4. Where a transverse watertight bulkhead is located within the transverse extent of assumed damage and is stepped in way of a double bottom or side tank by more than 3.05 m (10 ft), the double bottom or side tanks adjacent to the stepped portion of the transverse watertight bulkhead is to be considered as flooded simultaneously.

5. If the distance between adjacent transverse watertight bulkheads or the distance between the transverse planes passing through the nearest stepped portions of the bulkheads is less than the longitudinal extent of damage given in 3-12-5/5i), only one of these bulkheads should be regarded as effective.

## 7 Criteria

The following damage stability criteria are to be satisfied:

- i) The final waterline, taking into account sinkage, heel, and trim, is to be below the lower edge of any opening through which progressive flooding may take place. Such openings are to include air pipes and those openings which are capable of being closed by means of weather-tight doors or hatch covers and exclude those openings closed by means of watertight manhole covers and flush scuttles, small watertight cargo tank hatch covers which maintain the high integrity of the deck, remotely operated watertight sliding doors, and side scuttles of the non-opening type.
- ii) In the final stage of flooding, the angle of heel due to unsymmetrical flooding is not to exceed 20°.
- iii) The stability in the final stage of flooding is to be investigated and may be regarded as sufficient if the righting lever curve has a positive range of at least 20° beyond the position of equilibrium in association with a maximum residual righting lever of at least 100 mm (3.9 in.) within this range. The area under the righting arm curve within this range shall not be less than 0.0175 m-rad. Unprotected openings are not to become immersed at an angle of heel within the prescribed minimum range of residual stability unless the space in question has been included as a floodable space in calculations for damage stability. Within this range, immersion of any of the openings referred to in 5-12-5/5i) and any other openings capable of being closed weather-tight may be authorized.
- iv) The initial metacentric height of the damaged vessel in the final condition of flooding for the upright position shall not be less than 50 mm.
- v) Unsymmetrical flooding shall be kept to a minimum consistent with efficient arrangements. Where it is necessary to correct large angles of heel, the means shall be automatic. The vessel shall maintain sufficient stability during intermediate stages of flooding.

## 9 Permeability

The permeability\*\* of compartments assumed to be damaged is to be as follows:

<i>Spaces</i>	<i>Permeability</i>
Appropriated to Stores	0.60
Accommodations	0.95
Machinery Spaces	0.85
Void Spaces	0.95
Spaces for Dry Cargo	0.95
Empty Fish Hold	0.95
Full Fish Hold	0.50
Tanks	0.95

\*\* Permeability of a space means the ratio of the volume within that space, which should be assumed to be occupied by fluid, to the total volume of that space.

## 11 Free Surface

The free surface effects are to be calculated in accordance with 5-12-4/11.5. Additionally, the free surface effect of a damaged non-consumable tank may be omitted from the damage stability calculations.



### 13 Subdivision

The machinery spaces, working, cargo and accommodation spaces in the hull are to be separated by bulkheads made watertight up to the freeboard deck.

A collision bulkhead is to be fitted forward, complying with the relevant provisions of 3-2-7/3.1 applicable to cargo ships. In vessels having a long superstructure at the fore end, the collision bulkhead is to extend weather-tight up to the superstructure deck.

An aft peak bulkhead is to be fitted and made watertight up to the freeboard deck. The aft peak bulkhead may be stepped below the freeboard deck provided the degree of safety of the vessel with regard to subdivision is not diminished.

Arrangements made to maintain the watertight integrity of the watertight subdivisions in way of openings therein is to comply with the relevant provisions of Section 3-2-7 applicable to cargo ships.

PART

5

CHAPTER 12 Fishing Vessels (2001)

SECTION 6 Equipment

1 Wire Rope (2014)

Both anchor chains may be replaced with wire rope, having strength not less than the required tabular Grade 1 chain, on vessels less than 30.5 m (100 ft) in length. Wire rope having strength not less than the required tabular Grade 1 chain, may be used in lieu of the chain cable of one anchor on vessels between 30.5 m (100 ft) and 40 m (130 ft) in length, provided normal chain cable is provided for the second anchor. In general, wire ropes of trawl winches may be used to comply with the anchor cable requirement in this paragraph. Where wire ropes are substituted for anchor chain, the length of the wire rope is to be 1.5 times that of the chain it is replacing. A short length chain cable of the required size is to be fitted between the wire rope and the anchor, having a length of 12.5 m (41 ft) or the distance between anchor in stowed position and winch, whichever is less.

## PART

# 5

## CHAPTER 12 Fishing Vessels (2001)

### SECTION 7 Machinery Equipment and Systems

#### 1 Inclinations

Main propulsion and all auxiliary machinery essential to the operation of the vessel is to be capable of operating with the vessel upright or inclined transversely to 15 degrees either way under static conditions and up to 22.5 degrees under dynamic conditions or inclined longitudinally up to 7.5 degrees statically or dynamically or combination of these conditions. The Administration may permit deviation from these angles, taking into consideration the type, size and service conditions of the vessel.

For Emergency Equipment and Switchgear refer to 4-1-1/17.

#### 3 Liquid Petroleum Gas

Where liquid petroleum gas is used in the galley, the installation is to comply with a recognized standard, such as 46CFR-Subpart 58.16. Liquefied or non-liquefied combustible gas containers used for heating or cooking are considered ship's stores and are not covered in these Rules.

#### 5 Electrical Installation

##### 5.1 General (2014)

On vessels whose length is less than 30.5 m (100 ft) and the main engines are self-sustaining and no mechanical refrigeration is required for the catch, only one generator will be required.

##### 5.3 Emergency Lighting

In addition to the 4-6-2/5.3, emergency lighting is to be provided in fish handling and fish processing spaces.

##### 5.5 Cables – Construction

Cables are to be constructed and sized in accordance with a recognized standard. They are to be suitable for marine application, flame retardant and have copper conductors of stranded type, except sizes need exceeding 1.5 mm<sup>2</sup> (16 AWG) may have solid conductors. Refer also to 4-6-4/13.1.

#### 7 Refrigeration Plant (2014)

The refrigeration plant is to be in accordance with Part 6, Chapter 2 of the *Steel Vessel Rules*. For spaces containing toxic refrigerants, see Section 6-2-11 of the *Steel Vessel Rules* and Section 5-12-8 of these Rules. However, where separated spaces for toxic refrigerants are not practicable, the refrigerating machinery may be installed in the machinery spaces provided that in addition to the leak detection and water spray systems special consideration is given to the ventilation arrangements, appropriate gas detectors are fitted, protection of the refrigeration machinery from damage and provided that the propulsion machinery and essential auxiliaries can be operated from the navigation bridge.

PART

5

CHAPTER 12 Fishing Vessels (2001)

SECTION 8 Ammonia Refrigeration Systems (2014)

1 Application

**1.1 Indirect Refrigeration Systems**

Where ammonia is used as a primary refrigerant in an indirect refrigeration system compliance with the requirements of Section 6-2-11 of the *Steel Vessel Rules* is required.

**1.3 Direct Expansion Refrigeration Systems**

Where ammonia is used as a primary refrigerant in a direct expansion refrigeration system, compliance with the applicable requirements of Section 6-2-11 of the *Steel Vessel Rules* is required unless modified herein.

3 Refrigeration Machinery Space

**3.1 General**

3.1.1

Pressure Vessels and heat exchangers are to be:

- i) Manufactured in accordance with a recognized standard acceptable to ABS
- ii) Fitted with appropriate overpressure protection, and;
- iii) Hydrostatically tested in the presence of Surveyor

3.1.2

An emergency response plan outlining the actions to be taken by the crew to safely address an ammonia leak or release is to be provided on board. The plan is to include instructions for the crew to immediately leave any area where ammonia is detected.

3.1.3

The direct expansion ammonia refrigeration system may only be used for cargo and processing refrigeration systems. The use of direct expansion ammonia refrigeration systems for air conditioning or ship's stores is not permitted.

3.1.4

All refrigeration machinery is to be located in a refrigeration machinery room. Only the distribution refrigeration piping, valves, controls and evaporators may be located outside of the refrigeration machinery space.

3.1.5

Documentation is to be submitted verifying that the refrigeration machinery is suitable for the intended service.

### 3.3 Design Consideration

#### 3.3.1 Location of Refrigeration Machinery

- i)* In general, the refrigeration units and associated equipment which contain ammonia are to be located in a dedicated space. However, equipment other than refrigeration machinery may be permitted in the refrigeration machinery space on a case by case basis, but is to be limited to that necessary considering the space and arrangement of the vessel. In such case, any additional equipment that is essential for the safe operation of the vessel located in the refrigeration machinery space is to be capable of being operated from the navigating bridge and be of the type suitable to operate under all conditions, including an ammonia release. Any other additional equipment which may represent a source of ignition is to automatically shut down and de-energize from outside the space in the event of a detected ammonia release in conjunction with 5-12-8/3.13.2iv).
- ii)* The refrigeration machinery space is to be separated by gastight bulkheads and decks from other spaces
- iii)* Refrigeration machinery is to be adequately protected from mechanical damage and fitted with spill coamings

#### 3.3.2 Access and Openings

- i)* Accesses to the refrigerated machinery space are to be accordance with the following requirements:
  - a)* A minimum of two widely separated means of escapes are to be provided, one of which shall lead directly of the open deck. Water screens are to be provided above access doors and operable manually from outside the compartment and automatically in accordance with 5-12-8/3.15.2ii).

One of the means of escape may be a vertical ladder through a hatch to the weather. In that case, a water screen need not be fitted in the weather but a water deluge system that covers the area of the latter and entrance to any ladder trunk is to be provided.
  - b)* The access doors or hatches are to be gastight and self-closing with no holdback arrangements and are to open outward from the refrigeration machinery space.

Where it is determined impractical for the access door or hatch to be of the self-closing type due to their size and/or function (vertical hatch, etc.), a placard requiring them to be closed except when in use would be acceptable.
  - c)* Access doors are not to open to the accommodation spaces.
  - d)* Where one access is from a Category “A” machinery space, it is to be fitted with double doors, with a minimum space of 1.5 m (4.9 ft) between each door. The doors are to be self-closing and gastight with no holdback arrangements and the space between each door is to be provided with an independent ventilation system, the exhaust from which is to be led to the atmosphere. Alternative access arrangements will be specially considered provided a similar level of safety is maintained.
- ii)* Access corridors leading to the refrigerating machinery space are to be ventilated by means of an independent mechanical exhaust ventilation system. This will not be required if the ventilation system required by 5-12-8/3.3.3 below is also arranged to draw from the access corridors.
- iii)* Duct, pipe and cable penetrations of bulkheads and decks of the ammonia refrigerating machinery space are to be made gastight.

### 3.3.3 Ventilation of the Refrigeration Machinery Space

The ammonia refrigerating machinery space is to be efficiently ventilated by means of mechanical exhaust ventilation designed in accordance with the following requirements:

- i) The ventilation system is to be independent of other shipboard ventilation systems and is to be powered independently of the rest of the electrical equipment in the space so that shutting down the electrical power to the space does not affect ventilation.
- ii) The ventilation system is to be designed for continuous operation and alarmed at a manned control station upon failure.
- iii) The capacity of the ventilation system is to be of sufficient capacity to ensure at least 30 air changes per hour based on the total empty volume of the space.
- iv) Means are to be provided for stopping the ventilation fans and closing the ventilation openings from a readily accessible position located outside of the refrigeration machinery space.
- v) Air inlet openings are to be positioned as low as practicable in the space being ventilated and exhaust openings as high as practicable to ensure that no ammonia accumulates in the space.
- vi) Exhaust duct outlets are to be positioned at least 10 m (33 ft) from air intake openings, openings to accommodation spaces and other enclosed spaces, and at least 2 m (6.5 ft) above the open deck.

The 10 m (33 ft) distance may be reduced to 3 m (10 ft) provided:

- a) The refrigeration machinery space is fitted with a water deluge system that covers the entire space, including the inlet area to the mechanical extraction ventilation system, see 5-12-8/3.3.6 and;
- b) An emergency response plan outlining the actions to be taken by the crew to safely address an ammonia leak or release requiring any openings within 10 m (33 ft) to be closed immediately upon activation of the 25 ppm alarm is to be maintained on board.
- c) In lieu of meeting the requirements of 5-12-8/3.3.vi)a), an approved gas dispersion study, developed to a standard acceptable to ABS, may be considered provided it is shown that the concentration of ammonia within 10 m (33 ft) of intake openings, openings to accommodations spaces and other enclosed spaces, and within 2 m (6.5 ft) above the main deck does not exceed 100 ppm. In addition, an emergency response plan meeting the requirements of 5-12-8/3.3.vi)b) is to be provided.
- vii) Ventilation fans are to be of non-sparking construction in accordance with 4-8-3/11 of the *Steel Vessel Rules*.

### 3.3.4 Emergency Ventilation of Ammonia Refrigeration Machinery Space

Ammonia refrigerating machinery spaces are to be provided with an emergency mechanical type gas evacuation system to quickly dissipate a catastrophic leak of ammonia to reduce the risk of fire and explosion. The system is to be designed and constructed in accordance with the following requirements.

- i) The gas evacuation system is to be independent of other shipboard ventilation systems; however, it need not be independent of the ventilation system required by 5-12-8/3.3.3.
- ii) The gas evacuation system is to be arranged to automatically start when the concentration of ammonia in the space exceeds 300 ppm.
- iii) The combined capacity of the ventilation and gas evacuation fans is to be based upon the larger of the following:
  - a) A volume to ensure 40 air changes per hour based on the total empty volume in the space; or

b) The capacity calculated using the following formula:

$$Q = kG^{0.5}$$

where

$Q$  = minimum combined capacity, in m<sup>3</sup>/s (ft<sup>3</sup>/s)

$k$  = 0.07 (3.66)

$G$  = mass of ammonia in the largest refrigerating unit, in kg (lbs)

- iv) The gas evacuation system controls are to be positioned outside the space.
- v) The exhaust duct outlets are to be positioned at least 10 m (33 ft) from air intake openings, openings to accommodation spaces and other enclosed areas, and at least 2 m (6.5 ft) above the open deck. In addition, the vent outlets are to be directed upward and arranged so that the discharge of any ammonia vapors is away from accommodations and other enclosed areas, except as otherwise permitted for the normal ventilation outlet.
- The 10 m (33 ft) distance can be reduced to 3 m (10 ft) subject to the conditions identified in 5-12-8/3.3.3vi).
- vi) Gas evacuation fans are to be of non-sparking construction in accordance with 4-8-3/11 of the *Steel Vessel Rules*.

### 3.3.5 Drainage of Ammonia Refrigeration Machinery Space

- i) The ammonia refrigeration machinery space is to be provided with an independent bilge system.
- ii) The deck plating is to be arranged to facilitate easy cleaning and drying. No other plating above the deck is to be provided.
- iii) Where a deluge system (see 5-12-8/3.3.6) is fitted, the draining and pumping arrangements are to be such as to prevent the build-up on free surfaces. The draining system is to be sized to remove not less than 125% of the capacity of the water-deluge system.

### 3.3.6 Deluge System

Where a water deluge system is fitted, the arrangements are to be as follows:

- i) The system is to be independent of other water spray systems except that used for water screens for room access doors.
- ii) The system may be a pressurized system or a gravity fed system. Where gravity fed, the resulting pressure after 30 minutes of operation is to be adequate for the nozzles to provide the required coverage and rate. In addition, the emergency response plan is to address the actions to be taken after the 30 minute time period.
- iii) The discharge nozzles in the protected space(s) are to be positioned such that the water spray is directed over the entire area containing the ammonia refrigeration machinery.
- In addition, the number and arrangement of the nozzles is to be such as to ensure an effective average distribution of water of at least 5 l/m<sup>2</sup>/min.
- iv) Where a pump is utilized, the system is to consist of two pumps, a tank with capacity to maintain a discharge for a period of 30 minutes to all the nozzles simultaneously in the protected space(s), the tank is to be fitted with adequate safety release arrangements, pressure gauge(s), level control and level gauge.
- v) Means are to be provided to automatically maintain the required pressure and water level in the tank. In the event of low pressure or low level, and audible alarm is to sound in the refrigeration machinery room, refrigeration cargo control room, if fitted, and the engine room.
- vi) The system is to be arranged for automatic startup if the concentration of ammonia in the space exceeds 300 ppm.

- vii) If protected by a deluge system, the electrical equipment in the ammonia refrigeration compartment is to be to IP55 enclosure, or otherwise determined suitable for the intended service.
- viii) The water deluge system is to be arranged for manual starting from a location near the refrigeration machinery and at each exit from the refrigerating machinery space and for automatic starting in accordance with 5-12-8/3.3.6vi) and 5-12-8/3.15.2ii).

### 3.3.7 Storage of Ammonia Cylinders

See 6-2-11/3.13 of the *Steel Vessel Rules*.

## 3.5 Materials

### 3.5.1

Components in contact with ammonia are not to contain copper, zinc, cadmium, or alloys of these materials.

### 3.5.2

Components of rubber or plastic materials likely to be exposed to ammonia are not to be used.

### 3.5.3

Materials for sea water cooled condensers are to be corrosion resistant to sea water.

## 3.7 Personnel Safety Equipment

### 3.7.1

An eye wash and shower unit is to be provided immediately outside the refrigerating machinery room.

### 3.7.2

The following safety equipment is to be provided and stored in a readily accessible protected location outside the refrigerating machinery room and is to be in addition to the requirement required by 4-5-2/15:

- i) At least two sets of ammonia protective clothing, including refrigerant gas mask, helmet, boots and gloves
- ii) At least two sets of firemen's outfit's complying with 4-5-2/15
- iii) Two or more power driven air compressors, to recharge breathing apparatus cylinders
- iv) One heavy duty adjustable wrench
- v) Bottles of boric acid, vinegar and eye cups

### 3.7.3

Fire hydrant in and near the refrigeration machinery space are to be provided with fog applicators.

## 3.9 Safety Devices

### 3.9.1

A rupture disc is not to be used in series with the safety relief device.

### 3.9.2

The discharge from the safety relief valve on the ammonia side is to be led into the sea below the lightest water line or into a water dump tank near the bottom of the tank.

### 3.9.3

Ammonia refrigeration systems are to be provided with automatic air purging devices. The discharge from the purging device is to be led overboard below the lightest water line or to the water dump tank such that the discharge opening is submerged at all times. Where the connection is lead overboard, the discharge pipe is to be of extra heavy construction.



### 3.9.4

Where condensers are cooled by fresh water which is re-circulated, the fresh water system is to be equipped with pH meters to activate audible and visual alarms in the event of an ammonia leak.

## 3.11 Piping Arrangements

### 3.11.1

All piping other than that which is directly part of the refrigeration equipment is to be designed and fabricated in accordance with the requirements of Section 4-4-2 and the following:

- i)* Ammonia pipes are to have provisions for expansion and contraction encountered in service. The use of metallic flexible hoses for this purpose will be subject to ABS approval.
- ii)* Where flexible bellows are intended to be used in the ammonia refrigerant system, details and test data to show their suitability for the intended service are to be submitted.
- iii)* Joints for piping conveying ammonia are to be butt welded as far as practicable. For pipes up to 25 mm (1 in.) nominal diameter, socket welded joints may be accepted. Flanged joints are to be kept to a minimum and precautions are to be taken prior to disconnecting any such joints during repair and maintenance.
- iv)* Piping for the discharge of cooling sea water from the condenser is to be independent of other sea water piping systems and is to be led directly overboard without passing through accommodations or Category A machinery spaces.
- v)* Oil traps and oil drains are to be provided at the low points in the refrigerant system. Gauge lines and branches to level controls are not to be in locations where oil is likely to accumulate.
- vi)* Overboard discharges are to be in accordance with 4-4-2/19 and 4-4-2/21.
- vii)* Control, isolation and thermal expansion valves are to be located in the refrigeration machinery space and not in the refrigerated space.

## 3.13 Electrical

### 3.13.1 General

In general, the electrical equipment and arrangements are to comply with Part 4, Chapter 6.

### 3.13.2 Equipment and Installations in Hazardous Areas

Ammonia refrigerating machinery spaces and storage spaces are considered as hazardous locations. Electrical Equipment and wiring are not to be installed in such locations unless essential for operational purposes. Where electrical equipment is installed in the above spaces, the following conditions are to be met:

- i)* Electrical equipment which is required to be operated in the event of ammonia leakage, such as vapor detection and alarm systems are to be of an intrinsically safe type.
- ii)* Emergency lighting fixtures of an explosion proof type are to be provided in the above spaces. The switches for the lights are to be double pole type and located outside these spaces.
- iii)* Electrical Motors for gas evacuation fans or ventilation fans, if used for gas evacuation systems, are not to be located in the fan ducts or inside the ammonia refrigerating machinery spaces. They are to be located outside the hazardous areas.
- iv)* For electrical equipment other than those referenced in 5-12-8/3.13.2i) and 5-12-8/3.13.2ii), means are to be provided for automatic de-energizing from outside the space when the concentration of ammonia vapor in the space exceeds 10,000 ppm.
- v)* Cables in these spaces are to be armored unless they will be de-energized from outside the space in accordance with 5-12-8/3.13.2iv) and the penetrations are to be through gas tight fittings.

### 3.15 Instrumentation, Control and Monitoring

#### 3.15.1 General

Instrumentation, control, and monitoring for the ammonia refrigeration system are to be in accordance with Section 6-2-10 of the *Steel Vessel Rules* and the following requirements.

#### 3.15.2 Ammonia Vapor Detection and Alarm System

- i) An ammonia vapor detection and alarm system to warn against the release of ammonia (liquid and/or vapor) is to be provided for the following locations:
  - a) The refrigerating machinery space: One detector per 36 m<sup>2</sup> (387 ft<sup>2</sup>) of floor space
  - b) One detector in the exhaust duct of the refrigerating machinery space ventilation system
  - c) The access corridors leading to the ammonia refrigerating machinery space
  - d) One detector in the ammonia storage space
- ii) If the concentration of ammonia exceeds 25 ppm, the detectors are to activate audible and visual alarms locally and at the manned control station. In addition, if the concentration of ammonia exceeds 300 ppm, the detectors are to:
  - a) Activate the water screens and deluge system
  - b) Activate the gas evacuation system, and
  - c) Initiate an automatic emergency shutdown process of the refrigeration equipment considering the criticality of the equipment and associated risks and as recommended by the refrigeration machinery manufacturer.
- iii) Additional ammonia vapor detectors, set to provide an alarm in a continuously manned space if the ammonia concentration exceeds 50 ppm, are to be provided in the discharge piping from the safety relief valves.

#### 3.15.3 Ammonia Vapor Detection and Alarm System

An ammonia vapor detection and alarm system to warn against the release of ammonia (liquid and/or vapor) is to be provided for the following locations:

**TABLE 1**  
**Instrumentation and Alarms (2014)**

Item		Display	Alarm	Remarks
Condenser	Leakage of ammonia into cooling fresh water system	pH Meter	Leakage	Where condensers are cooled by fresh water
Water Dump Tank	Level	Level	Low	
Ammonia Vapor Detection	Locations Mentioned in 5-12-6/3.15.2ii)		Exceed 25 ppm	
	Discharge pipes from safety valves		Exceed 500 ppm	
	Refrigerating Plant Automatic Stop		Stop – 300 ppm	
	Activation of Gas Evacuation		Activation – 300 ppm	

### 3.17 Tests and Inspections

#### 3.17.1

Gas tightness of openings or doors referred to in 5-12-8/3.3.2 is to be verified by the attending Surveyor.

#### 3.17.2

Electrical Isolation of the refrigeration equipment at the set limit of 10,000 ppm of ammonia is to be demonstrated

#### 3.17.3

Ventilation air changes required by 5-12-8/3.3.3iii) and 5-12-8/3.3.4iii)a) are to be verified by the attending Surveyor.

#### 3.17.4

Satisfactory operational test of the emergency ventilation system is to be verified by the attending Surveyor.

#### 3.17.5

Ammonia vapor detection and alarm system is to be demonstrated. This is to include a demonstration of the required audible and visual alarms and stopping of the refrigerating plant and activation of the gas evacuation system in accordance with 5-12-8/3.15.2.

#### 3.17.6

The required alarms and displays are to be verified for satisfactory operation at the predefined set points

#### 3.17.7

Automatic de-energizing of non-intrinsically safe electrical equipment required by 5-12-8/3.13.2iv) is to be demonstrated in the presence of the Surveyor.

## 5 Process Area, Cargo Holds, and Bait Freezer Spaces

### 5.1 General

#### 5.1.1 Application

- i) The distributed spaces are not to contain ammonia refrigeration machinery. The space may only contain the necessary ammonia piping, evaporators and valve controls associated therewith.
- ii) The supply lines and return lines from the ammonia refrigeration piping in the various spaces are to be provided with isolation valves located in the ammonia refrigeration machinery space which shall be closed automatically upon detection of ammonia concentration of 300 ppm.
- iii) If the entire volume of ammonia in an isolated branch was released into the space, the average ammonia concentration in that space shall not exceed 30% of the lower explosive limit.
- iv) Ammonia gas detection meeting the requirements of this Section is to be provided.
- v) All pipe joints are to be welded except where necessary to facilitate a connection of a valve, evaporator, etc.

#### 5.1.2

All refrigeration system heat exchangers are to be:

- i) Manufactured in accordance with a recognized standard acceptable to ABS
- ii) Fitted with appropriate overpressure protection, and
- iii) Hydrostatically tested in the presence of an ABS Surveyor.

5.1.3

An emergency response plan outlining the actions to be taken by the crew to safely address an ammonia leak or release is to be provided on board. The plan is to include instructions for the crew to immediately leave any area where ammonia is detected.

5.1.4

Direct expansion ammonia refrigeration systems may only be used for cargo and process refrigeration systems. The use of direct expansion ammonia refrigeration systems for air conditioning or ship's stores is not permitted.

5.1.5

All refrigeration machinery is to be located in a refrigeration machinery room. Only the distributed refrigeration piping, valves and evaporators may be located in the refrigerated spaces (i.e., process area, cargo holds, and bait freezer).

### 5.3 Design Considerations

#### 5.3.1 Location

- i) Any equipment and machinery installed in the refrigerated spaces (i.e., process area, cargo holds, and bait freezers) is to be limited to that necessary for the intended purpose of the space (e.g., processing, handling of product, storing of product, etc.)
- ii) The spaces containing the ammonia refrigeration circuits are to be separated by gastight steel bulkheads and decks from other spaces.
- iii) The refrigeration piping, valves, and evaporators are to be adequately protected from mechanical damage.

#### 5.3.2 Access Openings

Accesses to the refrigerated space (i.e., process area, cargo holds, and bait freezers) are to in accordance with the following requirements:

- i) A minimum of two widely separated means of escape are to be provided, one of which shall lead directly to the open deck.  
  
For the cargo holds and bait freezers, where it is determined that direct access to the weather is not practical due to the location and/or location of the space, then arrangements providing two widely separated means with at least one providing ready access to the weather (i.e., access to the weather is close to the location where the crew exist the cargo hold/bait freezer) will be acceptable subject to each crew member entering the space having a refrigerant gas mask readily available. The requirement for each crew entering the space to have a refrigerant gas mask readily available is to be indicated in the emergency response plan and posted at the access points to the space.
- ii) The arrangements for egress to the escape points are to be such that personnel do not have to climb over or under equipment, plate freezers, conveyors, etc.
- iii) Water screens are to be provided above access openings and operable manually from outside the compartment.
- iv) The access doors are to be gastight and self-closing with no holdback arrangements and are to open outward from the refrigerated space.  
  
Where it is determined impractical for access to be of the self-closing type due to their size and/or function (load door, vertical hatch, etc.) a placard requiring them to be closed except when in use would be acceptable.
- v) Access doors are not to open to the accommodation spaces.
- vi) Duct, pipe and cable penetrations of bulkheads and decks of the refrigerated spaces are to be made gastight.

- 5.3.3 Ventilation of the Refrigerated Space (i.e., Process Area, Cargo Holds, and Bait Freezer)
- i)* A safe and effective means to remove any ammonia vapors from the space and sweep the room with ventilation is to be provided.
  - ii)* The arrangements may be fixed or portable, but in all cases the ventilation fans and associated equipment are to be suitable to handle ammonia vapors. If portable, the equipment is to be stored in a readily accessible location.
  - iii)* The vapors are to be discharged to the weather in an area that does not have any sources of ignition nor openings to enclosed spaces in the vicinity.
  - iv)* The emergency response plan is to provide specific instructions to the crew regarding the actions to be taken for ammonia vapor removal. As a minimum, the emergency response plan is to explain the hazards involved and must address the procedures to be followed including the location of the equipment, where the equipment is to be located during vapor removal efforts, locations where the vapors can be safely discharged, protective clothing and equipment to be worn by the individuals handling the operation.
  - v)* The power supply for the ventilation is to be independent of the rest of the electrical equipment in the space so that shutting off the electrical power to the space does not affect the means of ventilation.
  - vi)* Any fixed ventilation system provided is to be independent of any other shipboard ventilation system.
- 5.3.4 Drainage of Ammonia Refrigerated Spaces (i.e., Process Area, Cargo Holds, and Bait Freezer)
- i)* Any bilge or drainage arrangement for each of the refrigerated space (i.e., process area, cargo holds, and bait freezer) is to be independent of drainage servicing other spaces.
  - ii)* The deck plating is to be arranged to facilitate easy cleaning and drying. No other plating above the deck is to be provided.
  - iii)* Where a water deluge system is fitted, the drainage and pumping arrangements are to be such as to prevent the build-up for free surfaces. The drainage system is to be sized to remove not less than 125% of the capacity of the water deluge system.
- 5.3.5 Deluge System
- Valves, hoses, etc., associated with the freezer tables and area surrounding these items is to be covered by a water deluge system. This system is to be capable of being manually activated locally as well as automatically discharge upon detection of 300 ppm of ammonia.
- The water deluge system is to meet the following requirements:
- i)* The system is to be independent but may also be used for the supply of water to the water screens required for access water curtains addressed in 5-12-8/5.3.2iii).
  - ii)* The system may be a pressurized system or a gravity fed system.  
  
Where the system is gravity fed, the tank capacity is to be sufficient for at least 30 minutes of operation for all nozzles supplied. In addition, the pressure after 30 minutes of operation is to still be adequate for the operation of the nozzles to provide the required coverage area and rate. Also, the emergency response plan is to address the actions to be taken after the 30 minute time period.
  - iii)* The number and arrangement of the nozzles is to be such as to ensure an effective average distribution of water of at least 5 l/m<sup>2</sup>/min.
  - iv)* Where the pressure is provided by pumps, the system is to consist of two pumps, a tank with a capacity to maintain discharge for a period of 30 minutes to all the nozzles simultaneously in the protected space(s). The tank is to be fitted with adequate safety relief arrangements, pressure gauge(s), level control and level gauges.

- v) Means are to be provided to automatically maintain the required pressure and water level in the tank. In the event of low pressure or low level, an audible alarm is to sound in the refrigeration machinery room, refrigeration cargo control room, if fitted, and the engine room.
- vi) The water deluge system is to be arranged to automatically start when the concentration of ammonia in the space exceeds 300 ppm.
- vii) Any electrical equipment which would be impacted by the water spray is to be to IP55 enclosure, or otherwise determined suitable for the intended service.

#### 5.3.6

The storage of ammonia cylinders in the refrigerated spaces (i.e., process area, cargo holds, and bait freezers) is not permitted.

### 5.5 Materials

#### 5.5.1

Components in contact with ammonia are not to contain copper, zinc, cadmium, or alloys of these materials.

#### 5.5.2

Components of rubber or plastic materials likely to be exposed to ammonia are not to be used.

#### 5.5.3

Materials used for sea water cooled condensers are to be corrosion resistant to sea water, as applicable.

### 5.7 Personnel Safety Equipment

#### 5.7.1

An eye wash and shower unit is to be provided immediately outside each refrigerated space.

#### 5.7.2

The following safety equipment is to be provided and stored in a readily accessible protected location outside the refrigerated space(s). The same equipment may be used to meet this requirement for multiple refrigerated spaces (i.e., process area, cargo holds, and bait freezer), provided it is readily accessible from each of those spaces. If the location of the equipment is not readily accessible to a particular refrigerated space, then additional sets of safety devices are to be provided in these areas.

The following safety equipment is in addition to the safety equipment required elsewhere by the Rules:

- i) At least two sets of ammonia protective clothing, including refrigerant gas mask, helmet, boots and gloves
- ii) At least two sets of firemen's outfit's complying with 4-5-2/15
- iii) Two or more power driven air compressors, to recharge breathing apparatus cylinders
- iv) One heavy duty adjustable wrench
- v) Bottles of boric acid, vinegar and eye cups

#### 5.7.3

Fire hydrant in and near the refrigerated spaces (i.e., process area, cargo holds, and bait freezer) are to be provided with fog applicators.

## 5.9 Safety Devices

### 5.9.1

Rapture disc is not to be used in series with safety relief valve.

### 5.9.2

The discharge from safety relief valves on the ammonia side is to be led into the sea below the lightest waterline or into the water dump tank near the bottom of the tank.

### 5.9.3

Ammonia refrigeration systems are to be provided with automatic air purging devices. The discharge from the purging devices is to be led overboard below the lightest water line or to the water dump tank such that the discharge opening is submerged at all times. Where the connection is lead overboard, the discharge pipe is to be of extra heavy construction.

## 5.11 Piping Arrangements

All piping is to be designed and fabricated in accordance with the requirements of Section 4-4-2 and the following:

### 5.11.1

Each supply line and return line from the ammonia refrigerating piping serving the various spaces is to be provided with an isolation valve located in the ammonia refrigeration machinery space. The isolation valve is to be clearly labeled and arranged so that it will be closed automatically upon detection of an ammonia concentration of 300 ppm in the associated refrigerated space.

### 5.11.2

The branch lines entering the space are to be arranged so that if the entire volume of ammonia in an isolated branch was released into the space, the average concentration in the space would not exceed 30% of the lower explosive limit.

### 5.11.3

Control, isolation and thermal expansion valves are to be located in the refrigeration machinery space and not in the refrigerated space (i.e., process area, cargo holds, and bait freezer).

### 5.11.4

The piping is to pass directly from the refrigeration machinery space into the refrigerated space. The piping is not to pass through any other spaces unless specially approved.

All pipe joints are welded except where necessary to facilitate a connection to a valve, evaporator, etc.

### 5.11.5

Joints for piping conveying ammonia are to be butt welded as far as practicable. For pipes up to 25 mm (1 in.) nominal diameter, socket welded joints may be accepted. Flanged joints are to be kept to a minimum and precautions are to be taken prior to disconnecting any such joints during repair and maintenance.

### 5.11.6

The ammonia piping is to have adequate provisions to allow for the expansion and contraction encountered in service.

### 5.11.7

No flexible hoses (metallic or non-metallic) are to be used except for the connection between the fixed piping and refrigeration system components on the freezer tables where needed for flexibility. Where permitted, any non-metallic hose is to be wired reinforced and fire resistant, and is to comply with 4-4-1/9.19.

5.11.8

Each potential source of release of the ammonia piping system (e.g., flanged joints, valve seals, etc.) is to be shielded to prevent any released ammonia from impacting the workers.

5.11.9

Oil traps and oil drains are to be provided at the low points of the refrigerant system. Gauge lines and branches to level controls are not to be in locations where oil is likely to accumulate.

5.11.10

Evaporators, piping, valves, etc., are to be provided with adequate protection from mechanical damage.

### 5.13 Electrical

These spaces are not required to be considered as hazardous areas insofar as electrical requirements are concerned provided that the entire volume of ammonia in an isolated branch, if released into the space, would not result in an average ammonia concentration in that space exceeding 30% of the lower explosive limit.

### 5.15 Instrumentation, Control and Monitoring

#### 5.15.1 Ammonia Vapor Detection and Alarm

The refrigerated spaces (i.e., process area, cargo holds, and bait freezers) are to be fitted with an ammonia vapor detection alarm system complying with the following:

- i) One detector per 36 m<sup>2</sup> (387 ft<sup>2</sup>) of the space's floor area is to be provided.
- ii) One detector is to be located immediately above each area containing a potential source of release (e.g., each flanged joint, valve, etc.).
- iii) Any access corridors leading to the refrigerated spaces (i.e., process area, cargo holds, and bait freezers).
- iv) If the concentration of ammonia exceeds 25 ppm, the detectors are to activate audible and visual alarms locally and at the manned control station. If the concentration of ammonia exceeds 300 ppm, the detectors are to activate an automatic emergency shutdown process considering the criticality of the equipment and associated risks and as recommend by the refrigeration machinery manufacturer to in order to safely isolate the ammonia from the refrigerated area.
- v) In addition, if the concentration of ammonia exceeds 300 ppm, the detectors are also to activate any water deluge system(s) installed in the space.

#### 5.15.2

Additional ammonia vapor detectors set to provide an alarm in a continuously manned space if the ammonia concentrations exceed 500 ppm, are to be provided in the discharge pipes from the safety relief valves, as applicable.

### 5.17 Test and Inspection

#### 5.17.1

Gas tightness of openings or doors referred to in 5-12-8/5.3.2 is to be verified by the attending Surveyor.

#### 5.17.2

Ammonia vapor detection and alarm system is to be demonstrated. This is to include a demonstration of the required audible and visual alarms.



PART

5

CHAPTER 12 Fishing Vessels (2001)

SECTION 9 Safety Requirements (2014)

1 General

Where a review of all or part of the requirements covered in this Chapter has been conducted by the Administration of the State whose flag the vessel is entitled to fly and found acceptable, the same will be acceptable to ABS. The designer or builder is to submit evidence that the Administration has reviewed the arrangements and that the details are acceptable to that Administration.

The requirements of this section are applicable to all vessels whose length does not exceed 90m (295ft) in length, regardless of their construction material.

Each reference to a regulation in this section means a regulation of the International Convention for The Safety of Life at Sea, 1974 (1974 SOLAS) as amended.

3 Fire Safety Measures

All vessels are to comply with the requirements of Part 4, Chapter 5, as applicable.

**3.1 Structural Fire Protection**

Vessels with a freeboard length exceeding 30.5 m (100 ft) as defined by 3-1-1/3.3 or which carry 12 people or more are to meet the following requirements:

3.1.1

The bulkheads and decks separating machinery spaces of Category A from accommodation spaces, service spaces or control stations shall be constructed of steel or equivalent and constructed to A-60 standard in accordance with the FTP Code. Decks and bulkheads separating control stations and emergency sources of power from accommodation and service spaces shall be constructed of steel or equivalent.

3.1.2

The boundary bulkheads and decks of galleys, paint lockers and any store rooms which contain highly flammable materials shall be constructed of steel or equivalent.

3.1.3

Stairways, lift trunks and other escape trunks shall be constructed of steel or equivalent material and be protected by self-closing doors at all levels unless specifically addressed through other sections of the Rules.

3.1.4

Penetrations through bulkheads referenced in 5-12-9/3.1.1, 5-12-9/3.1.2 and 5-12-9/3.1.3 for electric cables, pipes and vent ducts shall be in accordance with SOLAS Ch II-2/Regulation 9.3.

## 5 Life Saving Appliances and Equipment

### 5.1 Survival Craft

#### 5.1.1 All Vessels

Each vessel is to be provided with survival craft. The arrangement and location shall comply with the following:

- i) They shall carry on each side of the ship, one or more inflatable or rigid liferafts complying with the requirements of section 4.2 or 4.3 of the LSA Code and of such aggregate capacity as will accommodate the total number of persons on board;
- ii) They shall carry at least one rescue boat complying with the requirements of Chapter V of the LSA Code. A lifeboat may be accepted as a rescue boat, provided that it also complies with the requirements for a rescue boat.
- iii) Unless the liferafts required by 5-12-9/5.1.1i) are of a mass of less than 185 kg and stowed in a position providing for easy side-to-side transfer at a single open deck level, additional liferafts shall be provided so that the total capacity available on each side will accommodate 150% of the total number of persons on board;
- iv) If the rescue boat required by 5-12-9/5.3 is also a totally enclosed lifeboat complying with the requirements of section 4.6 of the Code, it may be included in the aggregate capacity required by 5-12-9/5.1.1i), provided that the total capacity available on either side of the ship is at least 150% of the total number of persons on board; and
- v) In the event of any one survival craft being lost or rendered unserviceable, there shall be sufficient survival craft available for use on each side, including any which are of a mass of less than 185 kg and stowed in a position providing for easy side-to-side transfer at a single open deck level, to accommodate the total number of persons on board.

In lieu of meeting the above requirements, vessels carrying less than 12 persons may carry on each side of the vessel one or more life rafts complying with the requirements of section 4.2 or 4.3 of the LSA Code of such aggregate capacity as will accommodate all persons on board.

#### 5.1.2 Flag Administrations Requirements

ABS will consider the flag Administration Safety Regulations as an alternative to the requirements of 5-12-9/5.1.1.

### 5.3 Personal Life Saving Appliances

Personal life saving appliances are to comply with Regulation III/32 of SOLAS.

### 5.5 Survival Craft Stowage, Embarkation and Launching Arrangements

All survival craft stowage, embarkation and launching arrangements are to comply with SOLAS Regulation III/13 and III/33.

## 7 Radio Communication Installations

Each vessel is to be provided with:

- i) A radiotelephone station complying with the provisions of Chapter IV of the 1974 SOLAS Convention, as amended.
- ii) An efficient means of communication between the radiotelephone station and the rest of the vessel.
- iii) At least one emergency position-indicating radio beacon (EPIRB).

## 9 Deck Coatings

The surfaces of all decks shall be provided with effective non-skid coatings or grating system to minimize the possibility of slipping. Abrasion resistant coatings are to be provided in working areas including holds for the stowage of nets and lines.

## 11 Emergency Engine Kill Switch

For vessels with a freeboard length less than 30m (100 ft) as defined by 3-1-1/3.3 or a total crew compliment of 12 or less, there is to be an engine kill switch provided on the deck.

## 13 Lifting Equipment Overload Trip

Provisions are to be provided to prevent any installed lifting appliances from producing a heeling moment greater than that approved in the vessels trim and stability booklet. See also 5-12-4/7.

PART

5

CHAPTER 12 Fishing Vessels (2001)

SECTION 10 Surveys

1 Surveys After Construction (2005)

The surveys after construction are to be carried out in accordance with the *ABS Rules for Surveys After Construction (Part 7)*.

# PART 5

## APPENDIX 1 Requirements for Building and Classing Vessels Intended for Service in Domestic Waters

*Note:* This Appendix is prepared to make provision for users of the Rules to design, build and operate vessels intended solely for restricted service in domestic waters. It is recommended that any vessel which may possibly change its service area from domestic to international at a future date should at least comply with the requirements listed in 5-A1/3.1, as applicable, so that the upgrading work for compliance with SOLAS, etc. will avoid essential conversion of the vessel's structural arrangements.

### 1 General (1 July 2010)

For a vessel intended for service in domestic waters, ABS will consider the Flag Administration's Ships Safety Regulations as an alternative in satisfying specific areas of the Rules. Where approved by the Committee for a particular service, the vessel will be classed and distinguished in the *Record* by the symbols **✕ A1** followed by class notation, **(Operational Area) Domestic Service**, (e.g., **✕ A1 U.S. Domestic Service**, etc.).

### 3 Requirements Replaced with National Regulations

The following requirements in the Rules may be replaced with the Regulations of the Flag Administration for those vessels intended solely for service in domestic waters:

#### 3.1 Basic Construction (2010)

<i>Section/Paragraph</i>	<i>Requirement</i>
3-2-4/1	Double Bottom
Section 3-2-7	Extra Bulkheads for Subdivision
3-2-7/7	Watertight Door on W.T. Bulkhead
Section 3-4-1	Structural Fire Protection
4-5-2/9, 4-5-2/11 & 4-5-3/3.1	Fixed Fire Fighting System in Engine Room
4-6-2/5	Emergency Generator Room

#### 3.3 Machinery and Equipment

<i>Section/Paragraph</i>	<i>Requirement</i>
4-2-1/3.3, 4-2-1/9.7, 4-2-1/11.7	Spare Pumps
4-6-2/5	Emergency Power
4-6-2/5.9	Emergency Switchboard
4-5-2/5.3	Emergency (Second) Fire Pump
Part 4, Chapter 7	Shipboard Automation <sup>(1)</sup>

*Note:*

- The applicable requirements in Part 4, Chapter 7 are to be fully complied with when the shipboard automation notation **ACCU** or **ABCU** is requested.