



RULES FOR

**SURVEY AFTER CONSTRUCTION
2017**

PART 7

**American Bureau of Shipping
Incorporated by Act of Legislature of
the State of New York 1862**

**© 2016 American Bureau of Shipping. All rights reserved.
ABS Plaza
16855 Northchase Drive
Houston, TX 77060 USA**

Rule Change Notice (2017)

The effective date of each technical change since 1993 is shown in parenthesis at the end of the subsection/paragraph titles within the text of each Part. Unless a particular date and month are shown, the years in parentheses refer to the following effective dates:

(2000) and after	1 January 2000 (and subsequent years)	(1996)	9 May 1996
(1999)	12 May 1999	(1995)	15 May 1995
(1998)	13 May 1998	(1994)	9 May 1994
(1997)	19 May 1997	(1993)	11 May 1993

Listing by Effective Dates of Changes from the 2016 Rules

The reference date which is indicated in the parentheses following the title of the requirement in this Part is the date that the requirement becomes effective [e.g., 7-3-2/3.15.3(a)i “Ballast Tanks” (1 July 2016) is to apply for vessels undergoing survey on or after 1 July 2016].

Notice No. 1 (effective on 1 July 2016) to the 2016 Rules, which is incorporated in the 2017 Rules, is summarized below.

EFFECTIVE DATE 1 July 2016 – shown as (1 July 2016)

<i>Part/Para. No.</i>	<i>Title/Subject</i>	<i>Status/Remarks</i>
7-3-1/13	Vessels with the SH, SHCM or CSR, AB-CM Notation	To specify that areas identified as critical areas should be specially considered when performing visual examination of spaces. (Incorporates Notice No. 1)
7-3-2/3.15.3(a)i	Ballast Tanks	To align the requirements with IACS requirements. (Incorporates Notice No. 1)
7-3-2/5.7.4(a)iv	<No Title>	To clarify that vessels’ parts that are inaccessible need not be surveyed or have thickness measurements taken. (Incorporates Notice No. 1)
7-3-2/5.7.4(b)vi	<No Title>	To clarify that vessels’ parts that are inaccessible need not be surveyed or have thickness measurements taken. (Incorporates Notice No. 1)
7-3-2/5.7.4(c)vi	<No Title>	To clarify that vessels’ parts that are inaccessible need not be surveyed or have thickness measurements taken. (Incorporates Notice No. 1)
7-3-2/5.7.4(d)vi	<No Title>	To clarify that vessels’ parts that are inaccessible need not be surveyed or have thickness measurements taken. (Incorporates Notice No. 1)
7-3-2/5.13.6(b) Note i	<No Title>	To clarify that what is to be included in the tank testing procedure. (Incorporates Notice No. 1)
7-3-2/5.14.6(b) Note i	<No Title>	To clarify that what is to be included in the tank testing procedure. (Incorporates Notice No. 1)
7-3-2/5.15.4(a)iii	<No Title>	To clarify that vessels’ parts that are inaccessible need not be surveyed or have thickness measurements taken. (Incorporates Notice No. 1)
7-3-2/5.15.4(b)v	<No Title>	To clarify that vessels’ parts that are inaccessible need not be surveyed or have thickness measurements taken. (Incorporates Notice No. 1)
7-3-2/5.15.4(c)v	<No Title>	To clarify that vessels’ parts that are inaccessible need not be surveyed or have thickness measurements taken. (Incorporates Notice No. 1)
7-3-2/5.15.4(d)v	<No Title>	To clarify that vessels’ parts that are inaccessible need not be surveyed or have thickness measurements taken. (Incorporates Notice No. 1)
7-3-2/5.19.4(a)iii	<No Title>	To clarify that vessels’ parts that are inaccessible need not be surveyed or have thickness measurements taken. (Incorporates Notice No. 1)

<i>Part/Para. No.</i>	<i>Title/Subject</i>	<i>Status/Remarks</i>
7-3-2/5.19.4(b)iii)	<No Title>	To clarify that vessels' parts that are inaccessible need not be surveyed or have thickness measurements taken. (Incorporates Notice No. 1)
7-3-2/5.19.4(b)v)	<No Title>	To clarify that vessels' parts that are inaccessible need not be surveyed or have thickness measurements taken. (Incorporates Notice No. 1)
7-3-2/5.19.4(c)iii)	<No Title>	To clarify that vessels' parts that are inaccessible need not be surveyed or have thickness measurements taken. (Incorporates Notice No. 1)
7-3-2/5.19.4(c)v)	<No Title>	To clarify that vessels' parts that are inaccessible need not be surveyed or have thickness measurements taken. (Incorporates Notice No. 1)
7-3-2/5.19.4(d)iii)	<No Title>	To clarify that vessels' parts that are inaccessible need not be surveyed or have thickness measurements taken. (Incorporates Notice No. 1)
7-3-2/5.19.4(d)v)	<No Title>	To clarify that vessels' parts that are inaccessible need not be surveyed or have thickness measurements taken. (Incorporates Notice No. 1)
7-3-2/5.21.6(b) Note i)	<No Title>	To clarify that what is to be included in the tank testing procedure. (Incorporates Notice No. 1)
7-A-16/Table 7	Minimum Requirements for CLOSE-UP Examination at Special Periodical Surveys – Bulk Carriers – Non Double Skin ESP and Bulk Carrier Features of Combination Carriers – Non Double Skin ESP	To clarify that vessels' parts that are inaccessible need not be surveyed or have thickness measurements taken. (Incorporates Notice No. 1)
7-A-16/Table 11	Minimum Requirements for CLOSE-UP Examination at Special Periodical Surveys – Tankers ESP (Oil Carriers and Oil Carrier Features of Combination Carriers – Double Hull) and Oil/Fuel Oil Tank Barges – Double Hull 122 meters (400 feet) and over in Length	To clarify the requirements for survey for structural elements. (Incorporates Notice No. 1)
7-A-16/Table 15	Minimum Requirements for CLOSE-UP Examination at Special Periodical Surveys – Bulk Carriers – Double Skin ESP and Bulk Carrier Features of Combination Carriers – Double Skin ESP	To clarify that vessels' parts that are inaccessible need not be surveyed or have thickness measurements taken. (Incorporates Notice No. 1)

EFFECTIVE DATE 1 January 2017 – shown as (2017)

<i>Part/Para. No.</i>	<i>Title/Subject</i>	<i>Status/Remarks</i>
7-1-1/1.7.1(b)	Bulk Carrier	To align the requirements with IACS UR Z11 Rev. 5.
7-1-1/1.7.1(c)	Ore Carrier	To align the requirements with IACS UR Z11 Rev. 5.
7-2-1/13.3.1(a)	Extension up to Three (3) Months	To clearly specify the “two-and-a-half year extension”.
7-2-1/13.3.1(b)	Extension up to One (1) Year	To clearly specify the “two-and-a-half year extension”.
7-3-2/1.13.4	Cargo Pump Room	To incorporate requirements from OCIMF 1.e) and ISGOTT 10.11.3.
7-3-2/1.21 (New)	Compressed Natural Gas Carriers	To consolidate survey requirements by relocating the requirements from the <i>ABS Guide for Vessels Intended to Carry Compressed Natural Gas in Bulk</i> .
7-3-2/5.23 (New)	Compressed Natural Gas Carriers	To consolidate survey requirements by relocating the requirements from the <i>ABS Guide for Vessels Intended to Carry Compressed Natural Gas in Bulk</i> .
7-5-1/3.37	Alternative Means	To clarify that a tailshaft condition monitoring system and/or similar program are acceptable in lieu of meeting some requirements for other systems.

<i>Part/Para. No.</i>	<i>Title/Subject</i>	<i>Status/Remarks</i>
7-6-2/3.1.1(t)	Fixed Gas and Foam Extinguishing Systems	To clarify the titles of the sections.
7-6-2/3.1.1(u)	Fixed Water Spray and Mist Systems	To clarify the titles of the sections.
7-7-1/9	Hydrostatic Testing	To clarify the requirements.
7-9-6/3.1	Annual Surveys	To provide sets of tests required to be done annually.
7-9-6/3.5	Special Surveys	To provide sets of tests required to be done annually.
7-9-23	Inventory of Hazardous Materials	To consolidate survey requirements by relocating the requirements from the <i>ABS Guide For The Inventory Of Hazardous Materials</i> .
7-11-2/3	Special Periodical Surveys	To correct the Special Periodical Survey (SPS) definition by removal the three (3) month window after the date of build for completion of SPS and to align with definition in 7-2-1/5 for vessels with unrestricted service.
7-11-4/1.5	Ballasting and Deballasting Systems	To indicate that pressure testing to 1.25 times the MAWP only applies to piping systems exposed to seawater.
7-11-7 (New)	Relocation or Reinstallation of Portable Diving Systems	To add requirements for relocation/reinstallation of a portable diving system.
7-A-4/23	Thickness Measurements Carried Out Afloat	To remove the requirement for submitting of request for thickness measurement afloat authorization, as it is no longer ABS Survey practice
7-A-11/Figure 3B (New)	Location for Hardness Measurements Across the Weldment	To clearly indicate location for hardness measurements during weld procedure qualification for repair of shafts.
7-A-14/15	Condition Monitoring (CM)	To add new requirements for Condition Based Maintenance.
7-A-14/18 (New)	Condition Based Maintenance (CBM)	To add new requirements for Condition Based Maintenance.

PART 7

Foreword (2001)

In an effort to facilitate usage and better maintain survey after construction Rules, ABS has consolidated twenty-two (22) ABS Rules and Guides into this “Rules for Survey after Construction” booklet for 2001. These requirements apply to and supersede all survey after construction Rules required by the ABS Rules and Guides listed in Chapter 1, Section 1, Subsection 1 “Application” (7-1-1/1) of these Rules. These Rules do not apply to any other ABS Rules or Guide containing survey after construction requirements unless a particular Rule or Guide references any of the survey requirements of the ABS Rules or Guides listed in 7-1-1/1.

Chapters 1 through 8 contains survey Rules that have common requirements for different vessel types and geographical service areas. Where survey requirements differ according to the vessel’s geographical limitation in these Rules, the chapter has been sectioned into Unrestricted Service, Great Lakes Service, and Rivers and Intracoastal Waterways Services.

Where survey requirements are common to different vessel types, each survey type will contain requirements applicable to all vessels. When additional requirements are applicable to a specific vessel type, or are in lieu of the common requirement, they will be listed after the requirements for all vessels. The requirements for vessels in the Enhanced Survey Program (ESP) have been incorporated into each survey type.

Chapter 9 contains survey requirements to maintain a Class Notation for an additional system or service.

Chapters 10 through 12 contain unique survey Rules for Floating Drydocks, Underwater Vehicles and Sailing Yachts not Receiving **AMS** Notation. The survey interval and survey requirements noted in these chapters only apply to these vessel types.

The Appendix includes several ABS Guides relating to survey after construction and also contains planning, reporting and certification of thickness measurement firms required by the Enhanced Survey Program.

In order to further explain the new formatting contained in these Rules, sample vessels and their applicable survey requirements are illustrated in the table on the following page.

Examples:

Sample Vessels:

- ☒ A1 Bulk Carrier, Ⓢ, ☒ AMS, ☒ ACCU (ESP)
- ☒ A1 Oil Carrier, Ⓢ, ☒ AMS (ESP)
- A1 Container Carrier, AMS, ACCU, OMBO
- ☒ A1 Barge, River, Bay and Sound Service

Survey Type	Bulk Carrier	Oil Carrier	Container Carrier	Barge
Annual Survey Hull				
All Vessel Requirements	7-3-2/1.1	7-3-2/1.1	7-3-2/1.1	7-3-2/1.1
Specific Vessel requirements	7-3-2/1.7	7-3-2/1.13		7-3-2/1.5
Intermediate Survey Hull				
All Vessel Requirements	7-3-2/3.1	7-3-2/3.1	7-3-2/3.1	7-3-2/3.1
Specific Vessel requirements	7-3-2/3.7	7-3-2/3.17		7-3-2/3.5
Special Periodical Survey Hull				
All Vessel Requirements	7-3-2/5.1	7-3-2/5.1	7-3-2/5.1	7-3-2/5.1
Specific Vessel requirements	7-3-2/5.7	7-3-2/5.13		7-3-2/5.5
Thickness Measurement requirements	7-3-2/5.7.3	7-3-2/5.13.4	7-3-2/5.1.14(c)	7-3-4/1 7-3-4/1.3
Drydocking Survey	7-4-1/1	7-4-1/1	7-4-1/1	7-4-1/1
Tailshaft Survey	7-5-1/1	7-5-1/1	7-5-1/1	Not applicable
Annual Survey Machinery				
All Vessel Requirements	7-6-2/1.1	7-6-2/1.1	7-6-2/1.1	7-6-2/1.1
Specific Vessel requirements		7-6-2/1.3		
OMBO notation			7-9-3/1.1	
Special Periodical Survey Machinery				
All Vessel Requirements	7-6-2/3.1	7-6-2/3.1	7-6-2/3.1	7-6-2/3.1
Specific Vessel requirements		7-6-2/3.3		
Boiler Survey	7-7-1	7-7-1	7-7-1	Not applicable
Annual Survey Automation	7-8-1	7-8-1	7-8-1	Not applicable
Special Periodical Survey Automation	7-8-2	7-8-2	7-8-2	Not applicable

PART
7

Rules for Survey After Construction

CONTENTS

CHAPTER 1	Conditions for Survey After Construction	1
	Section 1 General Information	3
CHAPTER 2	Survey Intervals	15
	Section 1 Vessels for Unrestricted Service.....	17
	Section 2 Vessels in Great Lakes Service.....	23
	Section 3 Vessels in Rivers and Intracoastal Waterway Service	25
	Section 4 Survey After Ocean Transit Tow.....	27
CHAPTER 3	Hull Surveys	28
	Section 1 Requirements for Internal Examination of All Vessels.....	31
	Section 2 Vessels for Unrestricted Service.....	35
	Section 3 Vessels in Great Lakes Service	135
	Section 4 Vessels in Rivers and Intracoastal Waterways Service.....	137
CHAPTER 4	Drydocking Surveys.....	138
	Section 1 Survey Requirements	139
CHAPTER 5	Tailshaft Surveys	141
	Section 1 Survey Requirements	143
	Section 2 Allowable Bearing Weardown.....	150
CHAPTER 6	Machinery Surveys	151
	Section 1 General	152
	Section 2 Survey Requirements	153
	Section 3 Vessels in Great Lakes Service.....	171
CHAPTER 7	Boiler Surveys	172
	Section 1 Survey Requirements	173
CHAPTER 8	Shipboard Automatic and Remote-control Systems.....	175
	Section 1 Annual Surveys.....	176
	Section 2 Special Periodical Surveys	177

CHAPTER 9	Survey Requirements for Additional Systems and Services.....	178
Section 1	Cargo Refrigeration Systems.....	183
Section 2	Hull Condition Monitoring System.....	189
Section 3	One Man Bridge Operated System.....	190
Section 4	Propulsion Redundancy System.....	191
Section 5	Quick Release System.....	192
Section 6	Thrusters and Dynamic Positioning System.....	193
Section 7	Vapor Emission Control Systems	199
Section 8	Fire Fighting Service	202
Section 9	Safety Standby Service.....	204
Section 10	Offshore Installations Support Service	206
Section 11	Oil Recovery Service	217
Section 12	Automatic or Remote Control and Monitoring Systems for Vessels in Port.....	219
Section 13	Bridge Design and Navigational Equipment/Systems	220
Section 14	Integrated Tug-Barge (ITB) Combinations Intended to Operate on the Great Lakes	221
Section 15	Environmental Safety.....	222
Section 16	Crew Habitability on Ships and Workboats.....	225
Section 17	Comfort on Ships and Yachts	227
Section 18	Compliance with the ILO Maritime Labour Convention, 2006 Title 3 Requirements.....	230
Section 19	Yachts	232
Section 20	Tailshaft Condition Monitoring	233
Section 21	Oil Carriers Equipped for Mooring at Single Point Mooring	234
Section 22	Inert Gas Systems for Ballast Tanks	235
Section 23	Inventory of Hazardous Materials	236
CHAPTER 10	Steel Floating Drydocks.....	237
Section 1	Survey Interval	238
Section 2	Hull Surveys.....	239
Section 3	Machinery Surveys	241
CHAPTER 11	Underwater Vehicles, Systems and Hyperbaric Facilities	242
Section 1	General	245
Section 2	Survey Interval.....	246
Section 3	Annual Surveys.....	247
Section 4	Special Periodical Surveys	252
Section 5	Survey for Transit Damage	255
Section 6	Replacement of Viewports.....	256
Section 7	Relocation or Reinstallation of Portable Diving Systems	257

CHAPTER 12	Sailing Yachts not Receiving AMS Notation	259
Section 1	Survey Intervals	260
Section 2	Hull Surveys	261
Section 3	Machinery Surveys	265
Section 4	Comfort on Yachts	266
APPENDIX	267
Section 1	Underwater Inspection in Lieu of Drydocking Surveys	279
Section 2	Survey of Voyage Repairs to Hull Structure	284
Section 3	Vessel Lay-up and Reactivation	286
Section 4	Additional Information for Hull Thickness Measurement	298
Section 5	Procedures for Certification of Firms Engaged in Thickness Measurement of Hull Structures	325
Section 6	Report on Thickness Measurement of Bulk Carriers – Non Double Skin (CSR and Non-CSR Vessels) and General Dry Cargo Vessels	327
Section 7	Report on Thickness Measurement of Oil Carriers – Non Double Hull, Ore/Oil Ships – Non Double Hull and Chemical Carriers, etc.	376
Section 8	Intermediate and Special Periodical Survey Preparation for ESP Vessels	404
Section 9	Reporting Principles for ESP Vessels.....	450
Section 10	Bronze and Stainless Steel Propeller Castings	462
Section 11	Repair and Cladding of Shafts	489
Section 12	Ultrasonic Examination of Carbon Steel Forgings for Tail Shafts	505
Section 13	Report on Thickness Measurement of Oil Carriers – Double Hull (CSR and Non-CSR Vessels)	515
Section 14	Surveys Based on Preventative Maintenance Techniques	553
Section 15	Report on Thickness Measurement of Bulk Carriers – Double Skin (CSR and Non-CSR Vessels)	575
Section 16	Thickness Measurement and Close-up Survey Requirements at Special Periodical Surveys.....	619
Section 17	Survey of Portable Industrial Modules	652

This Page Intentionally Left Blank

PART
7

CHAPTER 1 Conditions for Survey After Construction

CONTENTS

SECTION 1	General Information	3
1	Application	3
1.1	Chapters 1 through 9.....	3
1.3	Chapters 1 and 10 through 12.....	3
1.5	Appendix	4
1.7	Enhanced Survey Program (ESP) Notations.....	4
1.9	Expanded Survey (ESDC) Notations.....	6
3	Definitions	6
3.1	Active Corrosion	6
3.2	Air Pipe Head	6
3.3	Allowable Corrosion or Wastage Limit.....	6
3.5	Bay	7
3.7	Ballast Tank – All Vessels	7
3.9	Ballast Tank – Tankers ESP.....	7
3.11	Ballast Tank – Bulk Carriers ESP	7
3.13	Bulk Carrier	7
3.14	Bulk Carrier – Double Skin	7
3.15	Cargo Area – Tankers	7
3.16	Cargo Length Area – All Vessels.....	7
3.17	Chemical Carrier	7
3.19	Close-up Survey.....	7
3.21	Coating Condition	7
3.23	Combined Cargo/Ballast Tank – All Vessels	8
3.25	Corrosion Prevention System.....	8
3.27	Critical Structural Areas.....	8
3.28	Edge Corrosion	8
3.29	Excessive Corrosion.....	8
3.31	Extensive Area of Corrosion.....	8
3.33	General Dry Cargo Vessel (ESDC)	8
3.35	Grooving Corrosion	8
3.36	Lightering Service.....	9
3.37	Localized Corrosion.....	9
3.39	Oil.....	9
3.41	Oil Carrier	9
3.43	Oil Carrier – Double Hull.....	9
3.45	Overall Corrosion	9
3.47	Overall Survey	9
3.49	Panel	9
3.51	Pitting Corrosion.....	9

3.53	Prompt and Thorough Repair	9
3.54	Renewal Thickness.....	9
3.55	Representative Spaces/Tanks	9
3.56	Ro-Ro Definitions.....	10
3.57	Serious/Significant Corrosion	10
3.59	Spaces.....	10
3.60	Special Consideration.....	10
3.61	Substantial Corrosion	10
3.63	Superstructure Deck	10
3.65	Suspect Areas	11
3.67	Tanker	11
3.68	Topside Ballast Tanks	11
3.69	Transverse Section (Girth Belt/Belt)	11
3.71	Weld Metal Corrosion	11
3.73	Wind and Water Strakes.....	11
5	Notification and Availability for Survey.....	11
7	Damage, Failure and Repair.....	11
7.1	Examination and Repair	11
7.3	Suspension of Classification.....	12
7.5	Prompt and Thorough Repairs	12
7.7	Representation	13
9	Alterations	13
11	Welding and Replacement of Materials	13
11.1	Ordinary and Higher Strength Structural Steels.....	13
11.3	Special Materials	13
13	Incomplete Surveys	14
15	Vessels Confined to a Specific Location.....	14
17	Lay-up and Reactivation	14
17.1	Vessels for Unrestricted Service and in Rivers and Intracoastal Waterways Services	14
17.3	Vessels in Great Lakes Service.....	14
19	Vessels in Lightering Service.....	14
21	Vessels Utilized in Support of Military Operations.....	14
FIGURE 1.....		4
FIGURE 2.....		5
FIGURE 3.....		5
FIGURE 4.....		5
FIGURE 5.....		6
FIGURE 6.....		6

PART 7

CHAPTER 1 Conditions for Survey After Construction

SECTION 1 General Information

1 Application (2002)

1.1 Chapters 1 through 9 (2013)

The requirements for Survey After Construction contained in Part 7, Chapters 1 through 9 apply to the following ABS Rules and Guides:

- *Rules for Building and Classing Steel Vessels*
- *Rules for Building and Classing Steel Vessels Under 90 Meters in Length*
- *Rules for Building and Classing Steel Vessels for Service on Rivers and Intracoastal Waterways*
- *Rules for Building and Classing Bulk Carriers for Service on the Great Lakes*
- *Rules for Building and Classing Steel Barges*
- *Guide for Building and Classing Accommodation Barges*
- *Rules for Building and Classing High Speed Craft*
- *Rules for Building and Classing Offshore Support Vessels*
- *Rules for Building and Classing High-Speed Naval Craft*
- *Guide for Building and Classing Yachts*
- *Guide for Building and Classing Integrated Tug-Barge (ITB) Combinations Intended to Operate on the Great Lakes*
- *Guide for the Environmental Protection Notation for Vessels*
- *Guide for the Environmental Protection Notation for Offshore Units, Floating Installations, and Liftboats*
- *Guide for Hull Condition Monitoring Systems*
- *Guide for One Man Bridge Operated (OMBO) Ships*
- *Guide for Automatic or Remote Control and Monitoring Systems for Vessels in Port*
- *Guide for Bridge Design and Navigational Equipment/Systems*

1.3 Chapters 1 and 10 through 12 (2005)

The requirements for Survey After Construction contained in Part 7, Chapters 1 and 10 through 12 apply to the following ABS Rules and Guides:

- *Rules for Building and Classing Steel Floating Drydocks*
- *Rules for Building and Classing Underwater Vehicles, Systems and Hyperbaric Facilities*
- *Guide for Building and Classing Yachts*

1.5 Appendix (2013)

Additionally, the following Appendices are contained in Part 7:

- *Underwater Inspection in Lieu of Drydocking*
- *Survey of Voyage Repairs to Hull Structure*
- *Lay-up and for Reactivation of Laid-up Ships*
- *Hull Thickness Measurement*
- *Bronze and Stainless Steel Propeller Castings*
- *Repair and Cladding of Shafts*
- *Ultrasonic Examination of Carbon Steel Forgings for Tail Shafts*
- *Preventative Maintenance Techniques*

Note: SVR references in these Survey After Construction Rules refer to the *Rules for Building and Classing Steel Vessels*.

1.7 Enhanced Survey Program (ESP) Notations (2005)

Oil carriers including combination carriers, bulk carriers and chemical carriers, as defined in 7-1-1/3, are subject to an Enhanced Survey Program and will be identified in the *Record* by the notation, **ESP**. These vessels are to comply with the requirements identified in this Part as **ESP** vessels (e.g., Bulk Carriers ESP, etc.).

1.7.1 Ship Type and Enhanced Survey Program (ESP) Notations

1.7.1(a) Oil Carrier (1 July 2012). The ship type notation **Oil Carrier**, or equivalent (e.g., **Fuel Oil Carrier**), and the notation, **ESP** is to be assigned to seagoing self-propelled ships which are constructed generally with integral tanks and intended primarily to carry oil in bulk. Refer to definition of oil as noted in 7-1-1/3.39. This type notation is to be assigned to tankers of both single and double hull construction, as well as tankers with alternative structural arrangements, e.g., mid-deck designs. Typical midship sections are given in 7-1-1/Figure 1.

Note: Oil Tankers that do not comply with MARPOL I/19 may be subject to International and/or National Regulations requiring phase out under MARPOL I/20 and/or MARPOL I/21.

FIGURE 1

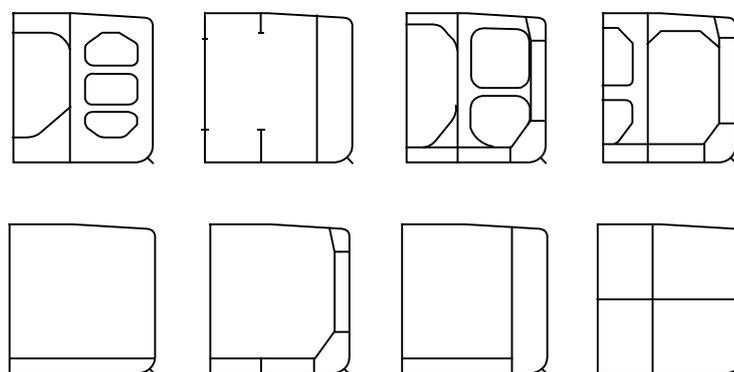

1.7.1(b) Bulk Carrier (2017). The ship type notation **Bulk Carrier**, or equivalent, **including those with self-unloading features**, and the notation, **ESP** is to be assigned to seagoing self-propelled ships which are constructed generally with single deck, double bottom, hopper side tanks and topside tanks and with single or double side skin construction in cargo length area and intended primarily to carry dry cargoes in bulk. Typical midship sections are given in 7-1-1/Figure 2.

FIGURE 2

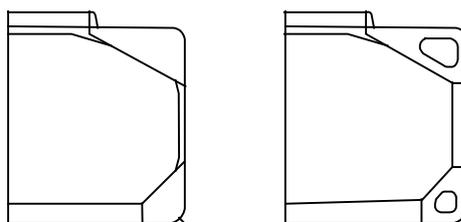

1.7.1(c) *Ore Carrier (2017)*. The ship type notation **Ore Carrier**, or equivalent, including those with self-unloading features, and the notation, **ESP** is to be assigned to seagoing self-propelled ships which are constructed generally with single deck, two longitudinal bulkheads and a double bottom throughout the cargo length area and intended primarily to carry ore cargoes in the center holds only. Typical midship sections are given in 7-1-1/Figure 3.

FIGURE 3

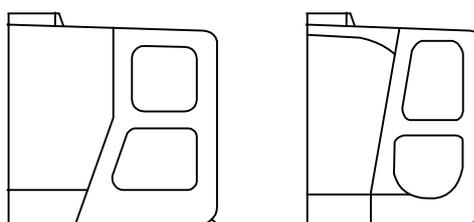

1.7.1(d) *Combination Carrier (1 July 2012)*. “Combination carrier” is a general term applied to ships intended for the carriage of both oil and dry cargoes in bulk; these cargoes are not carried simultaneously, with the exception of oily mixture retained in slop tanks. The ship types defined in *i)* and *ii)* below are to be considered to be combination carriers.

- i)* The ship type notation **Ore/Oil Carrier**, or equivalent, and the notation, **ESP** is to be assigned to seagoing self-propelled ships which are constructed generally with single deck, two longitudinal bulkheads and a double bottom throughout the cargo length area and intended primarily to carry ore cargoes in the center holds or of oil cargoes in center holds and wing tanks. Typical midship sections are given in 7-1-1/Figure 4.

Note: Ore/Oil carriers that do not comply with MARPOL I/19 may be subject to International and/or National Regulations requiring phase out.

FIGURE 4

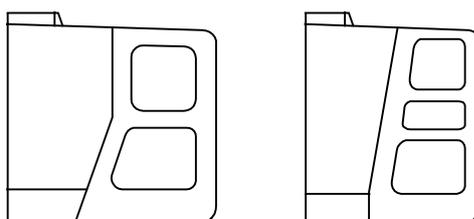

- ii) The ship type notation **Oil/Bulk/Ore (OBO) Carrier**, or equivalent, and the notation, **ESP** is to be assigned to seagoing self-propelled ships which are constructed generally with single deck, double bottom, hopper side tanks and topside tanks, and with single or double side skin construction in the cargo length area, and intended primarily to carry oil or dry cargoes, including ore, in bulk. Typical midship sections are given in 7-1-1/Figure 5.

Note: Oil/Bulk/Ore carriers that do not comply with MARPOL I/19 may be subject to International and/or National Regulations requiring phase out.

FIGURE 5

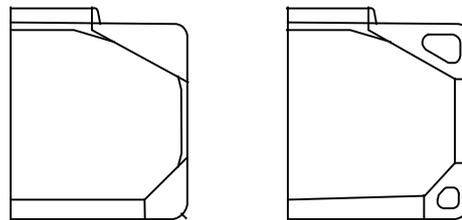

1.7.1(e) *Chemical Carrier.* The ship type notation **Chemical Carrier**, or equivalent, and the notation, **ESP** is to be assigned to seagoing self-propelled ships which are constructed generally with integral tanks and intended primarily to carry chemicals in bulk. This type notation is to be assigned to tankers of both single or double hull construction, as well as tankers with alternative structural arrangements. Typical midship sections are given in 7-1-1/Figure 6.

FIGURE 6

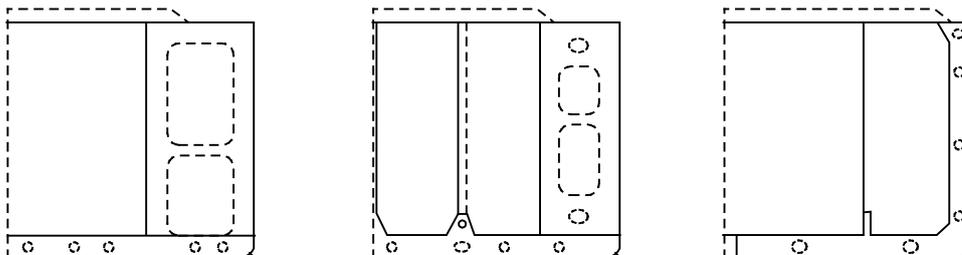

1.9 Expanded Survey (ESDC) Notations (2005)

General Dry Cargo Vessels as defined by 7-1-1/3.33 are subject to an Expanded Survey and will be identified in the *Record* by the notation **ESDC**. These vessels are to comply with the requirements identified in this Part as “General Dry Cargo Vessels (ESDC)”.

3 Definitions (1999)

3.1 Active Corrosion

Active Corrosion means loose scale and evidence of moisture penetration to the steel.

3.2 Air Pipe Head (1 July 2006)

Air Pipe Heads installed on the exposed decks are those extending above the freeboard deck or superstructure decks.

3.3 Allowable Corrosion or Wastage Limit

Allowable Corrosion or *Wastage Limit* is the acceptable corrosion limit for the vessel’s structure in a given area. Also known as *Allowable Limit*.

3.5 Bay

Bay is the area between adjacent transverse frames from longitudinal bulkhead to longitudinal bulkhead (or side shell).

3.7 Ballast Tank – All Vessels (1 July 2006)

A *Ballast Tank* is a tank which is used primarily for the carriage of salt water ballast.

3.9 Ballast Tank – Tankers ESP (1 July 2006)

A *Ballast Tank* is a tank which is used solely for the carriage of salt water ballast.

3.11 Ballast Tank – Bulk Carriers ESP (1 July 2006)

A *Ballast Tank* is a tank which is used solely for salt water ballast, or where applicable, a space which is used for both cargo and salt water ballast will be treated as a ballast tank when substantial corrosion has been found in that space. A double side tank is to be considered as a separate tank even if it is in connection to either the topside tank or the hopper side tank.

3.13 Bulk Carrier (1 July 2013)

A *Bulk Carrier* is a ship which is constructed generally with single deck, double bottom, topside tanks and hopper side tanks in cargo spaces, and is intended primarily to carry dry cargo in bulk. Combination Carriers are included. Ore and combination carriers are not subject to the IACS Common Structural Rules.

3.14 Bulk Carrier – Double Skin (1 July 2006)

A *Double Skin Bulk Carrier* is a ship which is constructed generally with single deck, topside tanks and hopper side tanks in cargo spaces, and is intended primarily to carry dry cargo in bulk, including such types as Ore Carrier and Combination Carrier, in which all cargo holds are bounded by a double-side skin (regardless of the width of the wing space).

3.15 Cargo Area – Tankers (1 July 2006)

Cargo Area is that part of the ship that contains cargo tanks, slop tanks and cargo/ballast pump rooms, cofferdams, ballast tanks, fuel tanks and void spaces adjacent to cargo tanks or slop tanks; and also deck areas throughout the entire length and breadth of the part of the ship over the above-mentioned spaces. Where independent tanks are installed in hold spaces, cofferdams, ballast or void spaces at the after end of the aftermost hold space or at the forward end of the forwardmost hold space are excluded from the cargo area.

3.16 Cargo Length Area – All Vessels (1 July 2006)

Cargo Length Area is that part of the vessel which contains cargo holds and adjacent areas including fuel tanks, cofferdams, ballast tanks and void spaces.

3.17 Chemical Carrier

A *Chemical Carrier* is a ship which is constructed or adapted and used for the carriage in bulk of any liquid product listed in the SVR Section 5C-9-17.

3.19 Close-up Survey

A *Close-up Survey* is a survey where the details of structural components are within the close visual inspection range of the Surveyor, i.e., normally within hand's reach.

3.21 Coating Condition (1 July 2006)

Coating Condition of hard coatings is defined as follows:

GOOD is a condition with only minor spot rusting.

FAIR is a condition with local breakdown at edges of stiffeners and weld connections and/or light rusting over 20% or more of areas under consideration, but less than as defined for *POOR* condition.

POOR is a condition with general breakdown of coating over 20% or more of areas, or hard scale at 10% or more of areas under consideration.

Reference is made to IACS Recommendation No.87 "Guidelines for Coating Maintenance & Repairs for Ballast Tanks and Combined Cargo / Ballast Tanks on Oil Tankers".

3.23 Combined Cargo/Ballast Tank – All Vessels (1 July 2011)

A *Combined Cargo/Ballast Tank* is a tank which is used for the carriage of cargo or ballast water as a routine part of the vessel's operation and will be treated as a ballast tank. Cargo tanks in which water ballast might be carried only in exceptional cases per MARPOL I/18(3) are to be treated as cargo tanks.

3.25 Corrosion Prevention System (2010)

A *Corrosion Prevention System* is normally considered a full hard protective coating. Hard Protective Coating is usually to be epoxy coating or equivalent. Other coating systems, which are neither soft nor semi-hard coatings, may be considered acceptable as alternatives, provided that they are applied and maintained in compliance with the manufacturer's specification.

3.27 Critical Structural Areas

Critical Structural Areas are locations which have been identified from calculations to require monitoring or from the service history of the subject ship or from similar or sister ships to be sensitive to cracking, buckling or corrosion that could impair the structural integrity of the ship.

3.28 Edge Corrosion (1 July 2013)

Edge Corrosion is defined as local corrosion at the free edges of plates, stiffeners, primary support members and around openings. An example of edge corrosion is shown in 7-A-4/Figure 3.

3.29 Excessive Corrosion

Excessive Corrosion is corrosion that exceeds the allowable limit.

3.31 Extensive Area of Corrosion

Extensive Area of Corrosion is corrosion of hard and/or loose scale, including pitting, over 70% or more of the plating surface in question, accompanied by evidence of thinning.

3.33 General Dry Cargo Vessel (ESDC) (1 July 2014)

A *General Dry Cargo Vessel (ESDC)* is a vessel carrying solid cargoes other than:

- Bulk carriers, Double Skin or Non-Double Skin, subject to ESP
- Dedicated container carriers
- Ro-ro cargo vessels
- Refrigerated cargo vessels
- Dedicated wood chip carriers
- Dedicated cement carriers
- Livestock carriers
- Deck cargo ships (A deck cargo ship is a ship that is designed to carry cargo exclusively above deck without any access for cargo below deck.)
- (1 July 2012) General dry cargo ships of double side-skin construction, with double side-skin extending for the entire length of the cargo area, and for the entire height of the cargo hold to the upper deck.

3.35 Grooving Corrosion (1 July 2013)

Grooving Corrosion is typically local material loss adjacent to weld joints along abutting stiffeners and at stiffener or plate butts or seams. An example of groove corrosion is shown in the appendix 7-A-4/Figure 4.

3.36 Lightering Service (1 July 2004)

Lightering Service is defined as the side-by-side mooring of two vessels, either while underway or stationary, for the purpose of transferring petroleum cargo, excluding bunkers, from a ship to be lightered to a service vessel. Both the lightered vessel and the service vessel are to be considered in lightering service.

3.37 Localized Corrosion

Localized Corrosion is by name local in nature and may be caused by a local breakdown in coating from contact damage, insufficient preparation or at areas of stress concentration.

3.39 Oil

Oil, for the purpose of the Rules, means petroleum in any form including crude oil, fuel oil, sludge, oil refuse and refined products other than petrochemicals which are subject to the provisions of Annex II of MARPOL 73/78.

3.41 Oil Carrier

An *Oil Carrier* is a ship which is constructed primarily to carry oil in bulk and includes a ship of similar types such as a Combination Carrier (Ore/Oil), etc.

3.43 Oil Carrier – Double Hull (2004)

An *Oil Carrier – Double Hull* is a ship which is constructed primarily to carry oil in bulk and includes similar types of ships such as a Combination Carrier (Ore/Oil), etc., which have the cargo tanks protected by a double hull which extends for the entire length of the cargo area, consisting of double sides and double bottom spaces for the carriage of water ballast or void spaces.

3.45 Overall Corrosion

Overall Corrosion appears as a non-protective rust which can uniformly occur on tank internal surfaces that are uncoated, or where coating has totally deteriorated. The rust scale continues to break off, exposing fresh metal to corrosive attack. Thickness cannot be judged visually until excessive loss has occurred.

3.47 Overall Survey

An *Overall Survey* is a survey intended to report on the overall condition of the hull structure and to determine the extent of additional Close-up Surveys.

3.49 Panel

Panel is the area between adjacent transverse frames from longitudinal stiffener to longitudinal stiffener.

3.51 Pitting Corrosion (1 July 2013)

Pitting Corrosion is defined as scattered corrosion spots/areas with local material reductions which are greater than the general corrosion in the surrounding area. Pitting intensity is defined in 7-A-4/Figure 5.

3.53 Prompt and Thorough Repair

A *Prompt and Thorough Repair* is defined as a permanent repair completed at the time of the survey to the satisfaction of the Surveyor.

3.54 Renewal Thickness (1 July 2013)

Renewal Thickness (t_{ren}) is the minimum allowable thickness, in mm, below which renewal of structural members is to be carried out.

3.55 Representative Spaces/Tanks (1 July 2006)

Representative Spaces/Tanks are those which are expected to reflect the condition of other spaces of similar type and service and with similar corrosion prevention systems. When selecting representative spaces, account should be taken of the service and repair history onboard and identifiable Critical Structural Areas and/or Suspect Areas.

3.56 Ro-Ro Definitions (2012)

3.56.1 Ro-Ro Ship

A ship which utilizes a loading ramp to enable wheeled vehicles to be rolled-on and rolled-off the ship.

3.56.2 Ro-Ro Passenger Ship(Ro-Pax)

A passenger ship with Ro-Ro spaces or special category spaces.

3.56.3 Ro-Ro Spaces

Spaces not normally sub-divided in any way and normally extending to either a substantial length or the entire length of the ship, in which motor vehicles with fuel in their tanks for their own propulsion and/or goods (packaged or in bulk, in or on rail or road cars, vehicles (including road or rail tankers), trailers, containers, pallets, demountable tanks or in or on similar stowage units or, other receptacles) can be loaded and unloaded normally in a horizontal direction.

3.56.4 Special Category Spaces

Those enclosed vehicle spaces above or below the bulkhead deck, into and from which vehicles can be driven and to which passengers have access. Special category spaces may be accommodated on more than one deck provided that the total overall clear height for vehicles does not exceed 10 m.

3.56.5 Securing Device

A device used to keep the door closed by preventing it from rotating about its hinges.

3.56.6 Supporting Device

A device used to transmit external or internal loads from the door to a securing device and from the securing device to the ship's structure, or a device other than a securing device, such as a hinge, stopper or other fixed device, that transmits loads from the door to the ship's structure.

3.56.7 Locking Device

A device that locks a securing device in the closed position.

3.57 Serious/Significant Corrosion

Serious/Significant Corrosion means more than 30% corrosion, and active scale is present. Active scale that is loose or has fallen off the structure.

3.59 Spaces (1 July 2008)

Spaces are separate compartments including holds, tanks, cofferdams, and void spaces bounding cargo holds, decks, and the outer hulls.

3.60 Special Consideration (1 July 2006)

Special Consideration or *Specially Considered* (in connection with close-up surveys and thickness measurements) means sufficient close-up inspection and thickness measurements are to be taken to confirm the actual average condition of the structure under the coating.

3.61 Substantial Corrosion

Substantial Corrosion is an extent of corrosion such that assessment of the corrosion pattern indicates a wastage in excess of 75% of the allowable margins, but within the acceptable limits.

Note: Wastage allowances may be found in 7-A-4/Table 1 and 7-A-4/Table 2.

(1 July 2013) For vessels built under the IACS Common Structural Rules, substantial corrosion is an extent of corrosion such that the assessment of the corrosion pattern indicates a measured thickness between $t_{ren} + 0.5$ mm and t_{ren} .

3.63 Superstructure Deck

For gauging purposes, a *Superstructure Deck* is a deck over an enclosed superstructure i.e., the first tier deck.

3.65 Suspect Areas

Suspect Areas are locations showing substantial corrosion and/or are considered by the Surveyor to be prone to rapid wastage.

3.67 Tanker

A *Tanker* is a ship which is constructed primarily to carry liquid cargo in bulk. Oil Carriers, Combination Carriers, Chemical Carriers and Liquefied Gas Carriers are included in this category.

3.68 Topside Ballast Tanks (2005)

Topside Ballast Tanks are ballast tanks in bulk carriers that normally extend along the length of the vessel's side and occupy the upper corners of the cargo hold.

3.69 Transverse Section (Girth Belt/Belt) (1 July 2006)

A *Transverse Section* includes all longitudinal members such as plating, longitudinals and girders at the deck, sides, bottom, inner bottom, longitudinal bulkheads, hopper sides, inner sides and bottoms of topside tanks. For transversely framed vessels, a transverse section includes adjacent frames and their end connections in way of transverse sections.

3.71 Weld Metal Corrosion

Weld Metal Corrosion is defined as preferential corrosion of the weld deposit. The most likely reason for this attack is galvanic action with the base metal which may start as pitting and often occurs on hand welds as opposed to machine welds.

3.73 Wind and Water Strakes

Wind and Water Strakes are the two (2) strakes located in the vicinity of the load waterline. Due to vessel's trim, the strakes may vary over the length of the vessel.

5 Notification and Availability for Survey

The Surveyors are to have access to classed vessels at all reasonable times. The Owners or their representatives are to notify the Surveyors on all occasions when a vessel can be examined in dry dock or on a slipway.

The Surveyors are to undertake all surveys on classed vessels upon request, with adequate notification, of the Owners or their representatives and are to report thereon to the Committee. Should the Surveyors find occasion during any survey to recommend repairs or further examination, notification is to be given immediately to the Owners or their representatives in order that appropriate action may be taken. The Surveyors are to avail themselves of every convenient opportunity for carrying out periodical surveys in conjunction with surveys of damages and repairs in order to avoid duplication of work. See also 1-1-8/5 of the *ABS Rules for Conditions of Classification (Part 1)*.

7 Damage, Failure and Repair

7.1 Examination and Repair

7.1.1

Damage, failure, deterioration or repair to hull, machinery or equipment, which affects or may affect classification, is to be submitted by the Owners or their representatives for examination by a Surveyor at first opportunity. All repairs found necessary by the Surveyor are to be carried out to the Surveyor's satisfaction.

7.1.2

Where repairs to hull, machinery or equipment, which affect or may affect classification, are planned in advance to be carried out, a complete repair procedure including the extent of proposed repair and the need for Surveyor's attendance is to be submitted to and agreed upon by ABS reasonably in advance.

Note: The above paragraph applies also to repairs during voyage. See Appendix 7-A-2.

The above paragraph is not intended to include maintenance and overhaul to hull, machinery and equipment in accordance with the manufacturer's recommended procedures and established marine practice and which does not require ABS approval; however, any repair as a result of such maintenance and overhauls which affects or may affect classification is to be noted in the ship's log and submitted to the Surveyor, as required by 7-1-1/7.1.

Material, components and equipment used in the course of a repair for which the Rules require certification are to be provided with the required certificates. For internal combustion engines with bores 300 mm (11.8 inches) or less, certification of the connecting rods is at the owner's discretion unless the Surveyor has a concern about the source of the connecting rods based on the condition of the replacement parts. Refer to 7-1-1/9 and 7-1-1/11.

7.1.3 (1 July 2012)

When deemed necessary by the Surveyor, testing as a result of damage, failure, deterioration or repair to the hull, machinery or equipment may be required. Tests are to be carried out in the presence of the Surveyor, and are to be in accordance with Section 3-7-1 of the Rules, as well as the *Guide for Nondestructive Inspection of Hull Welds*, where applicable.

7.3 Suspension of Classification

Failure to submit a damage, failure, deterioration or repair governed by 7-1-1/7.1.1 to a Surveyor for examination at first opportunity, or failure to notify ABS in advance of the repairs contemplated by 7-1-1/7.1.2, may result in suspension of the vessel's classification from the date of arrival at the first port of call after the initial damage, failure, deterioration or repair until such time as the damage, failure or deterioration is repaired to the Surveyor's satisfaction, or the repair is redone or evidence is submitted to satisfy the Surveyor that the repair was properly carried out.

7.5 Prompt and Thorough Repairs (1 July 2012)

Notwithstanding 7-1-1/7.1 and 7-1-1/7.3, any damage in association with wastage over the allowable limits (including buckling, detachment or fracture), or extensive areas of wastage over the allowable limits, which affects or may affect the vessel's structural, watertight or weathertight integrity, is to be promptly and thoroughly repaired. Areas to be considered include:

- Side shell frames, their end attachments and adjacent shell plating
- Deck structure and deck plating
- Bottom structure and bottom plating
- Inner bottom structure and inner bottom plating
- Watertight and oiltight bulkheads
- Hatch covers and hatch coamings, where fitted
- Weld connection between air pipes and deck plating
- Air pipe heads installed on the exposed decks
- Ventilators including closing devices, if any
- Bunker and vent piping systems

For double hull tankers and double skin bulk carriers subject to the Enhanced Survey Program, the following additional areas are to be considered:

- Side structure and side plating
- Inner side structure and inner side plating
- Longitudinal bulkhead(s) structure and longitudinal bulkhead(s) plating, where fitted
- Transverse watertight or oiltight bulkheads structure and transverse watertight or oiltight bulkheads plating

For locations where adequate repair facilities are not available, consideration may be given to allow the vessel to proceed directly to a repair facility. This may require discharging the cargo and/or temporary repairs for the intended voyage.

Additionally, when a survey results in the identification of structural defects or corrosion, either of which, in the opinion of the Surveyor, will impair the vessel's fitness for continued service, remedial measures are to be implemented before the ship continues in service.

Where damage found on structure is isolated and of a localized nature which does not affect the ship's structural integrity, consideration may be given by the Surveyor to allow an appropriate temporary repair to restore watertight or weather tight integrity and impose a Recommendation with a specific time limit.

7.7 Representation

Nothing contained in this section or in a rule or regulation of any government or other administration, or the issuance of any report or certificate pursuant to this section or such a rule or regulation, is to be deemed to enlarge upon the representations expressed in 1-1-1/1 through 1-1-1/7 of the *ABS Rules for Conditions of Classification (Part 1)* and the issuance and use of any such reports or certificates are to be governed in all respects by 1-1-1/1 through 1-1-1/7 of the above-referenced Part 1.

9 Alterations (1999)

No alterations which affect or may affect classification or the assignment of load lines, including substitutions of steel differing from that originally installed, alteration of original structural configuration, or change from riveted to welded joint, are to be made to a classed vessel unless plans of the proposed alterations are submitted and approved by an ABS Technical Office before the work of alteration is commenced. Such work, when approved, is to be carried out to the satisfaction of the Surveyor. Nothing contained in this section or in a rule or regulation of any government or other administration, or the issuance of any report or certificate pursuant to this section or such a rule or regulation, is to be deemed to enlarge upon the representations expressed in 1-1-1/1 through 1-1-1/7 of the *ABS Rules for Conditions of Classification (Part 1)* and the issuance and use of any such reports or certificates are to in all respects be governed by 1-1-1/1 through 1-1-1/7 of the above-referenced Part 1.

11 Welding and Replacement of Materials (1999)

11.1 Ordinary and Higher Strength Structural Steels

Welding or other fabrication performed on the structural steels listed in 2-1-2/Table 5 and 2-1-3/Table 5 of the *Rules for Materials and Welding (Part 2)* is to be in accordance with the requirements of Chapter 4 of the *Rules for Materials and Welding (Part 2)*.

11.3 Special Materials

11.3.1 Steel

Welding or other fabrication performed on other steels of special characteristics or repairs or renewals of such steel or adjacent to such steel is to be accomplished with procedures approved for the special materials involved. The procedures are to take into account the information provided under SVR 3-1-2/1 and be in accordance with requirements of Chapter 4 of the *Rules for Materials and Welding (Part 2)*.

11.3.2 Aluminum (2014)

Welding is not to be performed on aluminum alloys of the hull structure nor repairs or renewals commenced on such plating or adjacent to such plating without thorough and careful reference to the recommendations contained in Chapter 5 of the *ABS Rules for Materials and Welding (Part 2) – Aluminum and Fiber Reinforced Plastics (FRP)*. Substitution of aluminum alloys differing from those originally installed is not to be undertaken without approval.

13 Incomplete Surveys

When a survey is not completed, the Surveyor is to report immediately upon the work done in order that the Owners and the Committee may be advised of the parts still to be surveyed.

15 Vessels Confined to a Specific Location

For vessels confined to a specific location, such as a storage or a production vessel, the extent of the classification surveys will be specially considered.

17 Lay-up and Reactivation

17.1 Vessels for Unrestricted Service and in Rivers and Intracoastal Waterways Services

ABS is to be notified by the Owner that a vessel has been laid-up. This status will be noted in the *Record*, and surveys falling due during lay-up will then be held in abeyance until the vessel is reactivated. Lay-up procedures and arrangements for maintenance of conditions during lay-up may be submitted to ABS for review and confirmation by survey (See Appendix 7-A-3).

In the case of vessels which have been laid up for an extended period (i.e., six months or more), the requirements for surveys on reactivation are to be specially considered in each case, with due regard being given to the status of surveys at the time of the commencement of the lay-up period, the length of the period and the conditions under which the vessel had been maintained during that period.

Where the lay-up preparations and procedures have been submitted to ABS for review and confirmed by Annual Lay-up Surveys, consideration may be given to deducting part or all of the time in lay-up from the progression of survey intervals. This consideration is not applicable to vessels in the Enhanced Survey Program (ESP).

For vessels returning to active service, regardless of whether ABS has been informed previously that the vessel has been in lay-up, a Reactivation Survey is required.

17.3 Vessels in Great Lakes Service

Where the lay-up preparations and procedures have been submitted to ABS for review and verified by Annual Lay-up Surveys, consideration may be given to deducting part or all of the time in lay-up from the progression of survey intervals.

When applying for deductions, Owners are to provide details of out of service intervals since last credited surveys which do not include the normal winter lay-up months of January, February, and March.

19 Vessels in Lightering Service (1 July 2004)

ABS is to be notified by the Owner when a vessel has been put into lightering service. For a vessel engaged in lightering service, at each Annual, Intermediate and Special Periodical Survey, the additional requirements as contained in 7-3-2/1.1.15, 7-3-2/3.1.5 and 7-3-2/5.1.16 are to be complied with. Once the vessel has been removed from lightering service, these requirements will remain in effect through the completion of the next scheduled Intermediate or Special Periodical Survey, whichever occurs first.

21 Vessels Utilized in Support of Military Operations (1 July 2006)

Special consideration may be given in application of relevant sections of the *ABS Rules for Survey After Construction (Part 7)* to commercial vessels owned or full-time chartered by Governments, for use in support of military operations or non-commercial service.

PART
7

CHAPTER 2 Survey Intervals

CONTENTS

SECTION 1	Vessels for Unrestricted Service	17
1	Annual Surveys.....	17
3	Intermediate Surveys.....	17
5	Special Periodical Surveys	17
5.1	Commencement.....	17
5.3	Credited Date	18
5.5	Unusual Cases	18
7	Continuous Surveys.....	18
9	In-line Surveys	19
11	Drydocking Surveys	19
11.1	All Vessels.....	19
11.3	Accommodation Barges	19
11.5	Barges and Yachts	20
11.7	Passenger Vessels and High Speed Craft	20
13	Tailshaft Surveys	20
13.1	Intervals.....	20
13.3	Extensions.....	21
15	Tube Shaft Surveys	21
17	Boiler Surveys.....	21
17.1	Water-tube Boilers for Propulsion.....	21
17.3	Fire-tube Boilers for Propulsion	22
17.5	Auxiliary Boiler.....	22
SECTION 2	Vessels in Great Lakes Service	23
1	General Conditions	23
3	Annual Surveys.....	23
5	Intermediate Surveys	23
7	Special Periodical Surveys	23
9	Continuous Surveys.....	23
11	Year of Grace.....	24
13	Drydocking Surveys	24
15	Tailshaft Surveys	24
17	Boiler Surveys.....	24
SECTION 3	Vessels in Rivers and Intracoastal Waterway Service	25
1	General Conditions	25
3	Intermediate Surveys	25

5	Special Periodical Surveys	25
7	Drydocking Surveys	25
7.1	General	25
7.3	Salt Water Operation	26
7.5	Unscheduled Salt Water Operation	26
SECTION 4 Survey After Ocean Transit Tow		27

PART

7

CHAPTER 2 Survey Intervals

SECTION 1 Vessels for Unrestricted Service

1 Annual Surveys

Annual Surveys are to be made within three months before or after each anniversary date of the crediting of the previous Special Periodical Survey or original construction date. For vessels on Continuous Survey, all Continuous Survey requirements for those parts (items) due are generally to be completed each year. The Annual Survey will not be credited and the Certificate of Classification will not be endorsed unless Continuous Survey items which are due or overdue at the time of the Annual Survey are either completed or granted an extension.

Special Annual Survey (2011) – When **Annual Survey** is part of a vessel's Hull Classification notation, all of the requirements of Special Periodical Survey – Hull, except for tank testing, are required each year for the first four years of each five-year cycle. At the fifth year, a complete Special Periodical Survey – Hull, including tank testing is required. The drydocking survey in conjunction with the Special Annual Survey shall be carried out within the survey interval window of the Special Annual Survey.

LASH Barges – For steel barges carried aboard ship, and without Load Line Certificate, an Annual Survey will not be required, provided that in addition to the regular Special Periodical Survey at five (5) year intervals, a Special Intermediate Survey, equivalent to a Special Periodical Survey, is carried out about midway between Special Periodical Surveys.

3 Intermediate Surveys (1 July 2004)

Intermediate Surveys, where required by 7-3-2/3, are to be carried out either at or between the second and third Annual Surveys after Special Periodical Survey No. 1 and subsequent Special Periodical Surveys.

(1 July 2006) Those items which are additional to the requirements of the Annual Surveys may be surveyed either at or between the second and third Annual Surveys.

(1 July 2008) Concurrent crediting to both Intermediate Survey and Special Periodical Survey for surveys and thickness measurements of spaces is not acceptable.

5 Special Periodical Surveys

A Special Periodical Survey is to be completed within five years after the date of build or after the crediting date of the previous Special Periodical Survey. The fifth Annual Survey must be credited as a requirement of the Special Periodical Survey. The interval between Special Periodical Surveys may be reduced by the Committee.

(1 July 2008) Concurrent crediting to both Intermediate Survey and Special Periodical Survey for surveys and thickness measurements of spaces is not acceptable.

5.1 Commencement (1998)

A Special Periodical Survey may be commenced at the fourth Annual Survey and be continued with completion by the fifth anniversary date. Where the Special Periodical Survey is commenced prior to the fourth Annual Survey, the entire survey is to be completed within 15 months if such work is to be credited to the Special Periodical Survey.

5.3 Credited Date

A Special Periodical Survey will be credited as of the completion date of the survey but not later than five years from date of build or from the date recorded for the previous Special Periodical Survey. If the Special Periodical Survey is completed within three months prior to the due date, the Special Periodical Survey will be credited to agree with the effective due date.

5.5 Unusual Cases

Special consideration may be given to Special Periodical Survey requirements in the case of vessels of unusual design, in lay-up or in unusual circumstances.

(2016) In cases where the vessel has been laid up or has been out of service for a considerable period because of a major repair or modification and the owner elects only to carry out the overdue surveys, the next period of class will start from the expiry date of the previous due special survey. If the owner elects to carry out the next due special survey, the period of class will start from the survey completion date.

(1 July 2006) Consideration may be given for an extension of class of three (3) months maximum beyond the 5th year under exceptional circumstances. In this case, the next period of class will start from the expiry date of the Special Periodical Survey before the extension was granted.

7 Continuous Surveys (1998)

(1 July 2005) At the request of the Owner, and upon approval of the proposed arrangements, a system of Continuous Surveys may be undertaken, whereby the Special Periodical Survey requirements are carried out in regular rotation to complete all of the requirements of the particular Special Periodical Survey within a five-year period. The proposed arrangements are to provide for survey of approximately 20% of the total number of survey items during each year of the five-year period. Reasonable alternative arrangements may be considered.

(1 July 2006) Vessels on the Continuous Survey System are not exempt from other periodical surveys.

(1 July 2005) Continuous Surveys – Hull may not be undertaken of oil tankers, bulk carriers and combination carriers (such as ore/oil, etc.) and chemical tankers subject to the Enhanced Survey Program (ESP) and of general dry cargo vessels with the **ESDC** notation.

Each part (item) surveyed becomes due again for survey approximately five years from the date of the survey and the due parts (items) are generally to be completed each year. The Annual Survey will not be credited and the Certificate of Classification will not be endorsed unless Continuous Survey items which are due or overdue at the time of the Annual Survey are either completed or granted an extension. For Continuous Surveys, a suitable notation will be entered in the *Record* and the date of the completion of the cycle published.

Out of water drydocking, as required by 7-3-2/5.1.2, may be carried out at any time during the cycle, provided all requirements of Section 7-4-1 are met and thickness measurements, as required by 7-3-2/5.1.9, are carried out when the vessel is surveyed in drydock.

(1 July 2006) For vessels more than 10 years of age, the ballast tanks are to be internally examined twice in each five-year class period, i.e., once within the scope of the intermediate survey and once within the scope of the continuous system for the hull special periodical survey. The interval between any two such examinations should not exceed 36 months.

(1 July 2006) The Surveyor may extend the inspection at his/her discretion, to other items if the inspections carried out revealed any defects.

ABS may withdraw its approval for Continuous Survey if the Surveyor's recommendations are not complied with.

9 In-line Surveys

All items required to undergo Special Periodical Surveys, including but not limited to hull, machinery, automation and cargo refrigeration, are to be carried out at the same time and interval in order that they are recorded with the same crediting date. In cases where damage has necessitated extensive repairs and examination, the survey thereon may, where approved by the Committee, be accepted as equivalent to Special Periodical Survey.

11 Drydocking Surveys

11.1 All Vessels

(2011) There is to be a minimum of two examinations of the outside of a vessel's bottom and related items during each five-year special survey period. One such examination is to be carried out in conjunction with the Special Periodical Survey. In all cases, the interval between any two such examinations is not to exceed 36 months. See also 7-3-2/5.1.2. For vessels not subject to SOLAS operating solely in fresh water, the maximum interval is not to exceed five years.

(1 July 2004) Examinations of the outside of a vessel's bottom and related items is normally to be carried out with the vessel in drydock. However, consideration may be given to an alternative examination while the vessel is afloat by an approved underwater inspection, equivalent to a Drydocking Survey, subject to provisions of Appendix 7-A-1. This alternative will not be available for Drydocking Surveys concurrent with the Special Periodical Survey – Hull referred to in 7-3-2/5.1.2. Vessels 15 years of age or over will be subject to special consideration based on the vessel's survey status before being permitted to have such inspections. For vessels on Continuous Surveys – Hull, refer to 7-2-1/7.

(1 July 2005) For vessels 15 years of age or over subject to the Enhanced Survey Program (ESP), Underwater Inspections in Lieu of Drydocking (UWILD) will not be permitted at alternate Drydocking Surveys. Accordingly, all Rule-required Drydocking Surveys are to be carried out with the vessel on dry dock.

(1 July 2004) Compliance with 7-2-1/11.1 does not absolve the Owner from compliance with the requirements of SOLAS as amended, especially when shorter intervals between examination of the vessel's bottom for certain types of vessels are required.

(1 July 2004) For ESP Oil Tankers, ESP Combination Carriers, ESP Bulk Carriers, ESP Chemical Tankers, ESP Oil Tankers – Double Hull, ESP Bulk Carriers – Double Side Skin, and General Dry Cargo Vessels ESDC, reference should be made to the applicable Paragraphs of 7-3-2/5.

(1 July 2005) An extension of examination of a vessel's bottom of three (3) months beyond the due date may be granted in exceptional circumstances ⁽¹⁾. An underwater inspection by a diver may be required for such extensions.

Note 1 'Exceptional circumstances' means unavailability of dry-docking facilities; unavailability of repair facilities; unavailability of essential materials, equipment or spare parts; or delays incurred by action taken to avoid severe weather conditions. [See also 1-1-2/7.9iii) of the ABS Rules for Conditions of Classification (Part 1).]

(1 July 2005) These requirements are also applicable to vessels with geographical limitations except those vessels referred to in 7-2-2/13 and 7-2-3/7.

11.3 Accommodation Barges (2011)

In lieu of the requirements of 7-2-1/11.1, for barges classed as Accommodation Barges, prior to Special Periodical Survey No. 3, drydocking for survey will not be required and an approved underwater inspection in lieu of drydocking is allowed. However, the underwater inspection in lieu of drydocking shall be carried out at least two times in any five-year period with an interval not exceeding three years.

Commencing at Special Periodical Survey No. 3, there is to be a minimum of two examinations of the outside of a vessel's bottom and related items during each five-year special survey period. One such examination is to be carried out in conjunction with the Special Periodical Survey. In all such cases, the interval between any two such examinations is not to exceed 36 months. See also 7-3-2/5.1.2.

Consideration may be given to special circumstances which may justify an extension of the interval.

11.5 Barges and Yachts

In addition to the requirements of 7-2-1/11.1, for Barges and Yachts operating in salt water for less than six months each year, the maximum interval is not to exceed three years. For barges operating solely in fresh water, the maximum interval is not to exceed five years.

An approved underwater inspection by diver equivalent to a Drydocking Survey will be considered at alternate Drydocking Survey dates.

11.7 Passenger Vessels and High Speed Craft (2005)

In addition to the requirements in 7-2-1/11.1, a Drydocking Survey is to be carried out annually for passenger vessels subject to SOLAS and for High Speed Craft (HSC) vessels subject to the IMO HSC Code.

For passenger vessels and high speed craft, Drydocking Surveys are to be made within three months before or after the date of each annual anniversary date.

For passenger vessels, an approved underwater inspection by a diver (See Section 7-A-1), equivalent to a Drydocking Survey, may be considered at Drydocking Surveys not associated with the Special Periodical Survey – Hull referred to in 7-3-2/5.1.2. Vessels 15 years of age or over will be subject to special consideration based on the vessel's survey status before being permitted to have such inspections.

For vessels on Continuous Surveys – Hull, refer to 7-2-1/7.

13 Tailshaft Surveys (2016)

For surveys completed not more than 3 months in advance of the Survey Due Date, the crediting date will be the date of the Survey Due Date

13.1 Intervals

13.1.1 Oil-Lubricated Bearings

13.1.1(a) Every five (5) years

- A survey in accordance with Method 1, 2 or 3 and;

13.1.1(b) Every fifteen (15) years

- For shafts with keyed or keyless connection, a survey in accordance with Method 1 or Method 2.
- For shafts with a Flanged Propeller Connection a survey in accordance with Method 1, 2 or 3.

13.1.1(c) For vessels with **TCM** notation, refer to Section 7-9-20.

13.1.2 Closed Loop System Fresh Water Lubricated Shafts

13.1.2(a) Every five (5) years

- A survey in accordance with Method 1, 2 or 3 and;

13.1.2(b) Every fifteen (15) years

- A survey in accordance with Method 1

13.1.3 Water-Lubricated Bearings (Open Systems)

13.1.3(a) Every five (5) years, a survey in accordance with Method 4 for;

- Single shaft operating in fresh water only
- Single shaft provided with adequate means of protection against corrosion or fabricated from corrosion resistant material.
- Multiple shafts

13.1.3(b) Every three (3) years, a survey in accordance with Method 4 for single shaft configurations other than those listed in 7-2-1/13.1.3(a).

13.3 Extensions

Extension Surveys should normally be carried out within 1 month of the shaft survey due date and the extension counts from the shaft survey due date. If the extension survey is carried out more than 1 month prior to the shaft survey due date, then the period of extension counts from the date the extension survey was completed.

13.3.1 Oil-Lubricated Bearings or Closed Loop System Fresh Water Lubricated Shafts

For Closed Loop System Fresh Water Lubricated Shafts, the maximum interval between two surveys carried out according to Method 1 shall not exceed 15 years. An extension of not more than three months can be granted.

13.3.1(a) Extension up to Three (3) Months (2017). An extension up to three (3) months may be granted by the Surveyor, when requested by the Owner, provided a survey is carried out in accordance with 7-5-1/5.3.3. In the event an additional extension is requested, the requirements of the “one year extension” or “two-and-a-half year extension” are to be carried out and the shaft survey due date, prior to the previous extension, is extended for one year or a maximum of two-and-a-half years, respectively.

13.3.1(b) Extension up to One (1) Year (2017). An extension up to one (1) year may be granted by the Surveyor, when requested by the Owner, provided a survey is carried out in accordance with 7-5-1/5.3.2. No more than two (2) consecutive “one year” extensions may be granted. In the event “a two-and-a-half-year” extension is requested, the requirements in 7-5-1/5.3.1 are to be carried out and the shaft survey due date, prior to the previous extension(s), shall be extended for a maximum of 2.5 years.

13.3.1(c) Extension up to Two-and-a-half (2.5) Years. An extension of up to two-and-a-half (2.5) years may be granted by the Surveyor, when requested by the Owner, provided a survey is carried out in accordance with 7-5-1/5.3.1. No more than one extension can be granted. No further extension, of any other type, can be granted.

13.3.2 Water-Lubricated Bearings

For all types of propeller connections, the interval between two consecutive surveys may be extended after the execution of extension survey as follows:

13.3.2(a) Extension up to Three (3) Months. An extension up to three (3) months may be granted by the Surveyor, when requested by the Owner, provided a survey is carried out in accordance with 7-5-1/7.3.2.

13.3.2(b) Extension up to One (1) Year. An extension up to one (1) year may be granted by the Surveyor, when requested by the Owner, provided a survey is carried out in accordance with 7-5-1/7.3.1.

15 Tube Shaft Surveys

Tube shafts, if fitted, are to be examined at the same interval as tail shafts.

17 Boiler Surveys

17.1 Water-tube Boilers for Propulsion (1998)

17.1.1 Multiple Boilers (2007)

For vessels fitted with more than one boiler, a minimum of two surveys is to be carried out during each 5-year Special Periodical Survey period. One such survey is to be carried out in conjunction with the Special Periodical Survey. In all cases, the interval between any two such surveys is not to exceed 36 months. An extension of the survey up to three (3) months may be granted by the Surveyor in exceptional circumstances⁽¹⁾, provided a survey is carried out in accordance with 7-7-1/11.

(1 July 2009) For vessels on continuous survey of hull, two surveys are to be carried out during each 5 year cycle and may be aligned with the dry dock survey dates as long as the interval between surveys does not exceed 36 months.

In addition, annual examinations are to be carried out in accordance with 7-7-1/13.

Note: 1 “Exceptional circumstances” means, e.g., unavailability of repair facilities, unavailability of essential materials, equipment or spare parts, or delays incurred by action taken to avoid severe weather conditions.

17.1.2 Single Boiler (2007)

For vessels fitted with one boiler, the interval between surveys is not to exceed 2½ years for the first 7½ years. Thereafter, the boiler is to be surveyed annually. An extension of the survey not exceeding 6 months may be granted by the Surveyor provided a survey is carried out in accordance with 7-7-1/11, and provided the boiler is surveyed twice in every 5-year period for the first 7½ years.

In addition, annual examinations are to be carried out in accordance with 7-7-1/13 for the first 7½ years.

17.3 Fire-tube Boilers for Propulsion (2007)

A minimum of two surveys are to be carried out during first 5-year special periodical survey period. Thereafter, boilers are to be surveyed annually. The interval between any two surveys is not to exceed 36 months.

In addition, annual examinations are to be carried out in accordance with 7-7-1/13 for the first 5-year Special Periodical Survey period.

17.5 Auxiliary Boiler (1 July 2008)

Waste-heat or fired auxiliary boilers intended for working pressures above 3.4 bar (3.5 kgf/cm², 50 psi), a minimum of two surveys are to be carried out during each 5-year Special Periodical Survey period. One such survey is to be carried out in conjunction with the Special Periodical Survey. In all cases, the interval between any two such surveys is not to exceed 36 months. An extension of the survey up to three (3) months may be granted by the Surveyor in exceptional circumstances⁽¹⁾, provided a survey is carried out in accordance with 7-7-1/11.

In addition, annual examinations are to be carried out in accordance with 7-7-1/13.

For vessels on continuous survey of hull, the two surveys are to be carried out during each 5 year cycle and may be aligned with the dry dock survey dates as long as the interval between surveys does not exceed 36 months.

Note: 1 “Exceptional circumstances” means, e.g., unavailability of repair facilities, unavailability of essential materials, equipment or spare parts, or delays incurred by action taken to avoid severe weather conditions.

PART

7

CHAPTER 2 Survey Intervals

SECTION 2 Vessels in Great Lakes Service

1 General Conditions

Except as noted below, the requirements of Part 7, Chapters 1 through 12 apply to Great Lakes Service. Special consideration may be given where justified by special circumstances. Enhanced Survey Program requirements are not applicable to vessels classed Great Lakes Service.

Note: Owners should be cautioned that Load Line Certificate validity period may limit application of extended class survey interval.

Surveys falling due during January, February and March, when the vessel is in normal winter lay-up, may be considered deferred but must be completed before the vessel returns to operation.

3 Annual Surveys

Annual Surveys are to be made during each year of service.

5 Intermediate Surveys

Intermediate Surveys are to be carried out either at or between the second and third Annual Surveys after Special Periodical Survey No. 1 and subsequent Special Periodical Surveys.

7 Special Periodical Surveys

The first Special Periodical Survey becomes due five years after the date of build. Subsequent Special Periodical Surveys are due five years after the crediting date of the previous Special Periodical Survey. If a Special Periodical Survey is not completed at one time, it will be credited as of the completion date of the survey but no later than six years from date of build or from the date recorded for the previous Special Periodical Survey. The Special Periodical Survey – Hull credit date will be the last day of the month when the vessel was last visited on drydock for crediting Special Periodical Survey Drydocking as long as no item for Special Periodical Survey – Hull is overdue. The Load Line Certificate validity date will be the actual day of the month when the vessel was last visited on drydock.

9 Continuous Surveys

At the request of the Owner, and upon approval of the proposed arrangements, a system of Continuous Surveys may be undertaken, whereby the Special Periodical Survey requirements are carried out in regular rotation to complete all of the requirements of the particular Special Periodical Survey within a five-year period. Each part (item) surveyed becomes due again for survey approximately five years from the date of the survey and the due parts (items) are generally to be completed each year. The Annual Survey will not be credited and the Certificate of Classification will not be endorsed unless Continuous Survey items which are due or overdue at the time of the Annual Survey are either completed or granted an extension.

For Continuous Surveys, a suitable notation will be entered in the *Record* and the date of the completion of the cycle published. If any defects are found during the survey, they are to be dealt with to the satisfaction of the Surveyor. The Continuous Survey credit date and date for renewal of the Load Line Certificate will be the last day of the month when the vessel was last visited on drydock for credited Special Periodical Survey Drydocking as long as no item for Continuous Survey – Hull is overdue.

At a survey approximately two to three years after entering service and after each subsequent Continuous Survey – Hull has been credited, vessels will require the equivalent of an Intermediate Survey. Vessels on the Continuous Survey – Hull Program where 20% of the ballast tanks and cargo holds are examined and reported satisfactory each year would not be required to carry out the Intermediate Survey.

11 Year of Grace

To be eligible for the Year of Grace to complete the Special Periodical Survey within one year after the due date, the vessel is to be presented for survey up to a maximum of three months prior to the Special Periodical Survey due date. The survey may be commenced earlier than the above specified three months, provided it is commenced while the vessel is in continuous lay-up that extends to the date of the maximum 3 month limit.

If the Year of Grace Survey is satisfactory, the completion of the Special Periodical Survey may be deferred for a period not exceeding twelve months, provided the whole Special Periodical Survey is satisfactorily completed within six years from date of build or from the date recorded for the previous Special Periodical Survey.

13 Drydocking Surveys

For vessels classed Great Lakes Service, operating solely within the recognized boundaries for Great Lakes voyages, the regular interval for Drydocking Survey is five years. Consideration may be given to any special circumstances justifying an extension of the regular interval. When a satisfactory Year of Grace Survey has been carried out, including additional examinations afloat as may be deemed necessary by the attending Surveyor, this regular interval can be extended to a maximum of six years. See Note under 7-2-2/1.

15 Tailshaft Surveys

The regular interval for Tailshaft Surveys is five years and is intended to coincide with the Special Periodical Survey, including Year of Grace when recommended, subject to such additional examinations afloat as deemed necessary by the attending Surveyor.

The intervals for Tailshaft Surveys are to be the same as that required for Special Periodical Surveys.

17 Boiler Surveys (*1 July 2007*)

For vessels classed Great Lakes Service, operating solely within the recognized boundaries for Great Lakes voyages, the regular interval for Boiler Survey may be extended for up to one (1) year, when a satisfactory Year of Grace Survey has been carried out in conjunction with the Boiler Extension Survey.

PART 7

CHAPTER 2 Survey Intervals

SECTION 3 Vessels in Rivers and Intracoastal Waterway Service

1 General Conditions

Unless otherwise specified below, surveys after construction are to be in accordance with Part 7, Chapters 1 through 12. Annual Surveys are to be made during each year of service. Enhanced Survey Program requirements are not applicable to vessels classed Rivers and Intracoastal Waterways Service.

3 Intermediate Surveys

Intermediate Surveys are to be carried out either at or between the third and fourth Annual Surveys after Special Periodical Survey No. 1 and subsequent Special Periodical Surveys.

5 Special Periodical Surveys

A Special Periodical Survey is to be completed within six (6) years after the date of build or after the crediting date of the previous Special Periodical Survey. The sixth Annual Survey must be credited as a requirement of the Special Periodical Survey. The interval between Special Periodical Surveys may be reduced by the Committee.

7 Drydocking Surveys

7.1 General

The interval between Drydocking Surveys is not to exceed the maximum intervals given below with associated notes for types, services and operation:

Vessels/barges operating in salt water for a period of up to one (1) month per annum: single skin tank vessels, 3-year interval (note 1), double skin tank vessels, 6-year interval (note 2), all other vessels, 5-year interval (note 1 & 3).

All vessels/barges operating in salt water for a period of more than one (1) month and up to six (6) months per annum, 3-year interval.

All vessels/barges operating in salt water for a period of more than six (6) months per annum, drydocking is to be carried out two times in any 5-year period with an interval not exceeding three (3) years between drydockings. Consideration may be given to special circumstances which may justify an extension of the interval.

Notes:

- 1 The first Drydocking Survey after the date of build may be waived if after general examination afloat the Surveyor finds no indication of wastage or damage which would necessitate examination on drydock.
- 2 Internal surveys afloat are to be carried out at about three (3) years after the date of build or previous drydocking and the Surveyor is to be satisfied that there are no indications of wastage or damage which would necessitate examination on drydock.
- 3 Twelve (12) months maximum extension may be granted, provided after survey afloat the Surveyor is satisfied that there are no indications of wastage or damages which would necessitate examination on drydock. Vessels which have loadline certificates are to be drydocked within 60 months of the issuance of the loadline certificate.

7.3 Salt Water Operation

It is incumbent upon the Owner to advise ABS in writing of a vessel's period of operation in salt water.

7.5 Unscheduled Salt Water Operation

Where a vessel intended for fresh water operation is engaged in salt water operation for a period of time, intervals may be reduced accordingly.

PART

7

CHAPTER 2 Survey Intervals

SECTION 4 Survey After Ocean Transit Tow

For Accommodation Barges with self-elevating hulls, a specific survey is to be carried out on the self-elevating hull after the completion of an ocean transit tow. This survey should be carried out prior to elevating the hull and should include a comprehensive visual examination of the structure including helicopter support structure as well as surface nondestructive examination of critical locations. If the survey is carried out by the Owner and damage is found which affects or may affect classification, ABS is to be notified and arrangements are to be made for survey. If the survey is carried out by the Owner and no damages are found which affect or may affect classification, ABS is to be advised of the details of the tow and the inspection results, and a confirmation survey will be made at the next periodical survey.

PART
7

CHAPTER 3 Hull Surveys

CONTENTS

SECTION 1	Requirements for Internal Examinations of All Vessels	31
1	General	31
3	Preparations for Survey	31
5	Access to Structures	32
7	Equipment for Survey	33
9	Survey at Sea or at Anchorage	33
11	Thickness Measurements and Close-up Surveys	34
13	Vessels with the SH, SHCM or CSR, AB-CM Notation	34
SECTION 2	Vessels for Unrestricted Service	35
1	Annual Surveys	35
1.1	All Vessels	35
1.3	Accommodation Barges	39
1.5	Barges	39
1.7	Bulk Carriers – Non Double Skin ESP and Bulk Carrier Features of Combination Carriers – Non Double Skin ESP	40
1.9	High Speed Craft	44
1.11	Passenger Vessels	44
1.13	Tankers – (ESP and Non ESP) and Tank Barges and Oil Carrier Features of Combination Carriers	44
1.15	General Dry Cargo Vessels (ESDC)	49
1.17	Vessels Carrying Vehicles	50
1.19	Bulk Carriers – Double Skin ESP and Bulk Carrier Features of Combination Carriers – Double Skin ESP	53
1.21	Compressed Natural Gas Carriers	55
3	Intermediate Surveys	56
3.1	All Vessels	56
3.3	Accommodation Barges	57
3.5	Barges	57
3.7	Bulk Carriers – Non Double Skin ESP and Bulk Carrier Features of Combination Carriers – Non Double Skin ESP	58
3.9	General Dry Cargo Vessels (ESDC)	60
3.11	Tankers Non ESP	61
3.13	Tankers ESP (Oil Carriers and Oil Carrier Features of Combination Carriers – Non Double Hull)	62
3.15	Tankers ESP (Oil Carriers and Oil Carrier Features of Combination Carriers – Double Hull)	63
3.17	Bulk Carriers – Double Skin ESP and Bulk Carrier Features of Combination Carriers – Double Skin ESP	64
3.19	Chemical Carriers ESP	66

5	Special Periodical Surveys	67
5.1	All Vessels.....	67
5.3	Accommodation Barges	76
5.5	Barges	76
5.7	Bulk Carriers – Non Double Skin ESP and Bulk Carrier Features of Combination Carriers – Non Double Skin ESP.....	79
5.9	High Speed Craft.....	83
5.11	Liquefied Gas Carriers.....	84
5.13	Tankers ESP (Oil Carriers and Oil Carrier Features of Combination Carriers – Non-Double Hull)	86
5.14	Tankers ESP (Oil Carriers and Oil Carrier Features of Combination Carriers – Double Hull)	91
5.15	General Dry Cargo Vessels (ESDC)	95
5.17	Vessels Carrying Vehicles.....	99
5.19	Bulk Carriers – Double Skin ESP and Bulk Carrier Features of Combination Carriers – Double Skin ESP	100
5.21	Chemical Carriers ESP.....	104
5.23	Compressed Natural Gas Carriers	111
7	Extent of Thickness Measurement Requirements for those Areas of Substantial Corrosion within the Cargo Area.....	113
7.1	All Non ESP Vessels and General Dry Cargo Vessels (ESDC) ..	113
7.3	Bulk Carriers – Non Double Skin ESP and Bulk Carrier Features of Combination Carriers – Non Double Skin ESP.....	113
7.5	Tankers ESP (Oil Carriers and Oil Carrier Features of Combination Carriers – Non Double Hull and Chemical Carriers)	116
7.7	Tankers ESP (Oil Carriers and Oil Carrier Features of Combination Carriers – Double Hull and Chemical Carriers)	118
7.9	Bulk Carriers – Double Skin ESP and Bulk Carrier Features of Combination Carriers – Double Skin ESP	122
9	Preparations for Surveys of ESP Vessels	126
9.1	Survey Program	126
9.2	Survey Planning Meeting.....	128
9.3	Survey at Sea or at Anchorage	128
9.5	Conditions for Survey	130
9.7	Equipment for Survey.....	130
10	Preparations for Surveys of ESDC Vessels.....	131
10.1	Survey Planning	131
10.3	Survey at Sea or at Anchorage	131
11	Documentation on Board ESP Vessels	131
11.1	General.....	131
11.3	Survey Report File.....	132
11.5	Supporting Documents	132
11.7	Review of Documentation on Board	132
12	Documentation on Board General Dry Cargo Vessels (ESDC).....	133
13	Procedure for Thickness Measurements of ESP Vessels and General Dry Cargo Vessels (ESDC).....	133
13.1	General.....	133
13.3	Certification of Thickness Measurement Company	133
13.5	Reporting.....	133

15	Reporting and Evaluation of Surveys of ESP Vessels	133
15.1	Evaluation of Survey Report	133
15.3	Reporting	134
FIGURE 1.....		129
SECTION 3	Vessels in Great Lakes Service.....	135
1	Definitions	135
3	Annual Hull Surveys.....	135
3.1	Bulk Carriers	135
5	Intermediate Surveys	135
5.1	Bulk Carriers and Combination Carriers	135
7	Special Periodical Surveys	135
7.1	All Special Periodical Surveys	135
7.3	Special Periodical Survey No. 3 and Subsequent Special Periodical Surveys.....	136
7.5	Special Periodical Survey No. 7 and Subsequent Special Periodical Surveys.....	136
9	Year of Grace Surveys.....	136
11	Drydocking Surveys	136
SECTION 4	Vessels in Rivers and Intracoastal Waterways Service	137
1	Special Periodical Surveys	137
1.1	Surveys on Drydocked Vessels	137
1.3	Thickness Measurements.....	137

PART 7

CHAPTER 3 Hull Surveys

SECTION 1 Requirements for Internal Examinations of All Vessels

1 General (2005)

The following apply to all internal examinations of any spaces such as tanks, holds, voids or machinery spaces:

- (1 July 2006) Where soft or semi-hard coatings have been applied, safe access is to be provided for the Surveyor to verify the effectiveness of the coatings and to carry out an assessment of the condition of internal structures, which may include spot removal of the coating. When safe access cannot be provided, the soft or semi-hard coating is to be removed. Should the soft or semi-hard coating be found no longer effective, sufficient cleaning, as required by the following Rules below, shall be carried out prior to survey.
- Based on conditions found, thickness measurements and means of access to the upper part of the tank or space should be required. Where extensive areas of wastage or structural damage are found, the extent of the overall examination may be expanded to other spaces.
- Casings, ceilings or linings, and loose insulation, where fitted, are to be removed, as required by the Surveyor, for examination of plating and framing.
- Compositions on plating are to be examined and sounded, but need not be disturbed if found adhering satisfactorily to the plating.
- (1 July 2012) In refrigerated cargo spaces the condition of the coating behind the insulation is to be examined at representative locations. The examination may be limited to verification that the protective coating remains effective and that there are no visible structural defects. Where POOR coating condition is found, the examination is to be extended as deemed necessary by the Surveyor. The condition of the coating is to be reported. If indents, scratches, etc., are detected during surveys of shell plating from the outside, insulations in way are to be removed as required by the Surveyor, for further examination of the plating and adjacent frames.

3 Preparations for Survey (2004)

3.1

The Owner is to provide the necessary facilities for a safe execution of the survey.

3.3

Tanks and spaces are to be safe for access, i.e., gas freed, ventilated, illuminated, etc.

3.5 (1 July 2006)

In preparation for survey and thickness measurements and to allow for a thorough examination, all spaces are to be cleaned including removal from surfaces of all loose accumulated corrosion scale. Spaces are to be sufficiently clean and free from water, scale, dirt, oil residues etc. to reveal corrosion, deformation, fractures, damages or other structural deterioration. However, those areas of structure whose renewal has already been decided by the Owner need only be cleaned and descaled to the extent necessary to determine the limits of the areas to be renewed.

3.7 (2005)

Sufficient illumination is to be provided to reveal corrosion, deformation, fractures, damages or other structural deterioration.

5 Access to Structures (1 July 2014)

5.1

For surveys, means are to be provided to enable the Surveyor to examine the hull structure in a safe and practical way. It is to be confirmed as far as practicable that means of access to all spaces are in good condition when examining internal spaces.

Walking on bulk cargo is not considered an acceptable means of access for carrying out close up surveys of cargo holds.

5.3

For surveys in cargo holds and ballast tanks, one or more of the following means for access, acceptable to the Surveyor, is to be provided:

- Permanent staging and passages through structures.
- Temporary staging and passages through structures.
- Hydraulic arm vehicles such as conventional cherry pickers, lifts and movable platforms. Single person hoists/lifts are not acceptable means for access
- Portable ladders
- Boats or rafts.
- Other equivalent means.

5.5 Close-up Survey on Bulk Carriers – Non Double Skin and Bulk Carriers Features of Combination Carriers – Non Double Skin

In lieu of the requirements of 7-3-1/5.3, the following requirements also apply.

5.5.1 Hull Structure other than Cargo Hold Shell Frames

For close-up surveys of the hull structure, other than cargo hold shell frames, one or more of the following means for access, acceptable to the Surveyor, is to be provided:

- Permanent staging and passages through structures
- Temporary staging and passages through structures
- Lifts and moveable platforms
- Boats or rafts
- Other equivalent means

5.5.2 Cargo Hold Shell Frames of Bulk Carriers less than 100,000 DWT

For close-up surveys of the cargo hold shell frames of bulk carriers less than 100,000 DWT, one or more of the following means for access, acceptable to the Surveyor, is to be provided:

- Permanent staging and passages through structures
- Temporary staging and passages through structures
- Hydraulic arm vehicles such as conventional cherry pickers, lifts and movable platforms
- Boats or rafts provided the structural capacity of the hold is sufficient to withstand static loads at all levels of water
- Other equivalent means

5.5.3 Cargo Hold Shell Frames of Bulk Carriers 100,000 DWT and Above

For close-up surveys of the cargo hold shell frames of bulk carriers 100,000 DWT and above, the requirements of 7-3-1/5.5.2 apply.

In addition, for vessels 10 years of age and over, the following also apply for Intermediate Surveys and Special Periodical Surveys.

- Either permanent or temporary staging and passage through structures for close-up survey of at least the upper part of hold frames
- Hydraulic arm vehicles such as conventional cherry pickers for surveys of lower and middle part of shell frames as alternative to staging

7 Equipment for Survey (2004)

7.1 (2008)

Thickness measurement is normally to be carried out by means of ultrasonic test equipment. The accuracy of the equipment is to be proven to the Surveyor, as required. Thickness measurements are to be carried out by a firm certified by ABS in accordance with Appendix 7-A-5.

The certification of the firm is not required with respect to thickness measurements of non-ESP/ESDC vessels under 90 meters in length, vessels in Great Lakes service or fishing vessels.

7.3

One or more of the following fracture detection procedures may be required if deemed necessary by the Surveyor:

- Radiographic examination.
- Ultrasonic examination.
- Magnetic particle examination.
- Dye penetrant examination.

7.5 Rescue and Emergency Response Equipment (1 July 2014)

If breathing apparatus and/or other equipment is to be used as 'Rescue and Emergency Response Equipment' then the equipment is to be suitable for the configuration of the space being surveyed.

9 Survey at Sea or at Anchorage (1 July 2004)

9.1

Survey at sea or at anchorage may be accepted, provided the Surveyor is given the necessary assistance from the personnel onboard. Necessary precautions and procedures for carrying out the survey are to be in accordance with 7-3-1/3, 7-3-1/5, 7-3-1/7 and additionally for ESP vessels, 7-3-2/9.1.

9.3 (1 July 2006)

A communication system is to be arranged between the survey party in the tank or space under examination and the responsible officer on deck. This system is also to include the personnel in charge of ballast pump handling if boats or rafts are used.

9.5

Explosimeter, oxygen-meter, breathing apparatus, life line and whistles are to be at hand during the survey.

9.7

When boats or rafts are used, appropriate life jackets are to be available for all persons onboard. Boats or rafts are to have satisfactory residual buoyancy and stability, even if one chamber is ruptured. A safety checklist is to be provided.

9.9 (1 July 2008)

Surveys of tanks or applicable holds by means of boats or rafts may only be undertaken with the agreement of the Surveyor, who is to take into account the safety arrangements provided, including weather forecasting and ship response under foreseeable conditions and provided the expected rise of water within the tank does not exceed 0.25 m and the water level is stationary.

Reference is made to the IACS Recommendation 39 - Guidelines for use of Boats or Rafts for Close-up Surveys.

11 Thickness Measurements and Close-up Surveys (2007)

The required thickness measurements are to be witnessed by a Surveyor. The Surveyor is to be onboard to the extent necessary to control the process.

The thickness measurement company's representative is to be part of the survey planning meeting to be held prior to commencing the survey.

In any kind of survey, i.e., Special Periodical, Intermediate, Annual or other surveys having the scope of the foregoing ones, thickness measurements of structures in areas where Close-up Surveys are required are to be carried out simultaneously with Close-up Surveys.

13 Vessels with the SH, SHCM or CSR, AB-CM Notation (1 July 2016)

For vessels with the **SH, SHCM** or **CSR, AB-CM** notation, an approved copy of the Construction Monitoring Plan shall be available onboard. When a critical area is being surveyed, the extent and scope of the survey shall be in accordance with the approved copy of the Construction Monitoring Plan.

During annual, intermediate, and special survey attention is to be given to the critical areas identified in the SHCM or CSR, AB-CM plan. Any identified areas in the SHCM or CSR, AB-CM plan, in the location surveyed, must be visually examined.

PART 7

CHAPTER 3 Hull Surveys

SECTION 2 Vessels for Unrestricted Service

1 Annual Surveys

1.1 All Vessels

(1 July 2011) The Master is to confirm that to the best of their knowledge the vessel has had no damages, failures, deteriorations, or repairs (including temporary repairs) to hull, machinery, or equipment which affected or may have affected classification since the last annual survey.

At each Annual Survey, the weather decks, hull plating and their closing appliances together with watertight penetrations are to be generally examined as far as practicable and placed in satisfactory condition. The survey is to include the following:

1.1.1 Protection of Cargo Hatch Openings

1.1.1(a) (1999) Confirmation that no unapproved changes have been made to the hatch covers, hatch coamings and their securing and sealing devices since the last survey. Exposed hatch covers are to be examined to confirm the structural integrity and capability of maintaining weathertightness. Where extensive areas of wastage of steel hatch covers are found, thickness measurements are to be carried out, and renewals or repairs made where wastage exceeds allowable margins. Where substantial corrosion is found, additional thickness measurements in accordance with 7-3-2/7 are to be taken to confirm the extent of substantial corrosion.

1.1.1(b) (1 July 2003) Where mechanically operated steel covers are fitted, examination of:

- Hatch covers; including plating and stiffeners and Close-up Survey of hatch cover plating
- Tightness devices of longitudinal, transverse and intermediate cross junction (gaskets, gasket lips, compression bars, drainage channels, drains, and non return valves, if fitted)
- Steel-to-steel contact between cover and coaming, support pads, cleats (including cross joint bolts and/or wedges)
- Clamping devices, retaining bars, cleating
- Chain or rope pulleys
- Guides
- Guide rails and track wheels
- Stoppers, etc.
- Wires, chains, gypsies, tensioning devices
- Hydraulic system essential to closing and securing
- Safety locks and retaining devices

1.1.1(c) (1 July 2003) Where wooden covers on portable beams or steel pontoon covers are fitted, examination of:

- Wooden covers and portable beams, carriers or sockets for the portable beams, and their securing devices
- *(1 July 2004)* Steel pontoons
- Tarpaulins

- Cleats, battens and wedges
- Hatch securing bars and their securing devices
- Loading pads/bars and the side plate edge
- Guide plates and chocks
- Compression bars, drainage channels and drain pipes (if any)

1.1.1(d) (1999) Examination, including Close-up Survey, of hatch coaming plating including deck connection, stiffeners, stays, pads, chocks and brackets. Where extensive areas of wastage are found, thickness measurements are to be carried out, and renewals or repairs made where wastage exceeds allowable margins. Where substantial corrosion is found, additional thickness measurements in accordance with 7-3-2/7 are to be taken to confirm the extent of substantial corrosion.

1.1.1(e) (2005) Random checking of the satisfactory operation of mechanically-operated hatch covers is to be made, including:

- Stowage and securing in open condition.
- Proper fit and efficiency of sealing in closed condition.
- Operational testing of hydraulic and power components, wires, chains and link drives.

1.1.1(f) Where the omission of gaskets has been approved, in accordance with SVR 3-2-15/11.1, the satisfactory condition of specially approved details such as labyrinths is to be confirmed in addition to 7-3-2/1.1.1(b).

1.1.2 Protection of Other Openings

1.1.2(a) Hatchways, manholes and scuttles in freeboard and superstructure decks.

1.1.2(b) Machinery casings, fiddley covers, funnel annular spaces, skylights, companionways and deckhouses protecting openings in freeboard or enclosed superstructure decks.

1.1.2(c) (2011) Portlights together with deadcovers, means of attachment, securing devices and gaskets.

1.1.2(d) (2011) Windows together with deadcovers, means of attachment, securing devices and gaskets or storm covers together with means of securing, as applicable.

1.1.2(e) (2011) Cargo ports, bow or stern access, chutes and similar openings in vessel's sides or ends below the freeboard deck or in way of enclosed superstructures.

1.1.2(f) (1 July 2006) Ventilators including closing devices where fitted, air pipes together with flame screens and weld connections to deck plating. All air pipe "closure devices" installed on the exposed decks are to be externally examined, randomly opened out and their condition verified. Scuppers, inlets and overboard discharges are to be externally examined as accessible including their attachment to shell and valves.

1.1.2(g) (2012) Watertight bulkheads, collision bulkheads, bulkhead penetrations, end bulkheads of enclosed superstructures and the operation of any doors in same.

(2007) In addition, for vessels fitted with self-unloading system, watertight conveyor belt doors are to be examined and operationally tested as far as practicable.

1.1.2(h) Weathertight doors and closing appliances for all of the above including stiffening, dogs, hinges and gaskets. Proper operation of weathertight doors and closing appliances to be confirmed.

1.1.2(i) (2012) Means provided to minimize water ingress through the spurling pipes and chain lockers.

1.1.3 Freeing Ports and Drainage (2012)

1.1.3(a) Freeing ports, together with bars, shutters and hinges.

1.1.3(b) Confirmation of satisfactory drainage from enclosed cargo spaces situated on the freeboard deck.

- 1.1.4 Protection of Crew
Guard rails, lifelines, gangways and deck houses accommodating crew.
- 1.1.5 Loading and Stability Information (2005)
Confirmation of loading guidance, stability data and damage control plans, as applicable. Loading instruments accepted for classification or approved stability computers installed to supplement the Trim and Stability booklet are to be confirmed in working order by use of the approved check conditions, as applicable. The user's instruction manual for the loading instrument or the stability computer is to be confirmed onboard. Additionally, for High Speed Craft, the operation manual is to be verified on board.
- 1.1.6 Load Line (2012)
Confirmation that no alterations have been made to the hull or superstructures which would affect the calculation determining the position of the load lines. Record of Conditions of Assignment is to be available onboard for reference. The Load Line marks are to be sighted, position checked, found plainly visible, and recut and/or painted, as required.
- 1.1.7 Anchoring Systems and Mooring Equipment (2012)
Anchors and chain cables, anchor windlass including foundation, prime mover, shafting, wildcats, brakes, controls and chain stoppers are to be examined, as far as possible.
Mooring and towing equipment is to be examined as far as possible and to be confirmed properly marked as applicable with any restriction associated with its safe operation.
(2006) Each windlass is to be operated, as far as possible, for braking, clutch functioning, lowering and hoisting of chain cable and anchor, proper riding of the chain over the wildcat, proper transit of the chain through the hawse pipe and chain pipe, and effecting proper stowage of the chain and anchor.
- 1.1.8 Structural Fire Protection (1 July 2015)
Verification that no changes have been made to the arrangement of structural fire protection, verification of the operation of manual and/or automatic fire doors, if fitted, random visual examination and operational testing of interior fire dampers, and verification that the means for escape from the accommodations, machinery spaces and other spaces are satisfactory.
- 1.1.9 Suspect Areas (1 July 2006)
Suspect areas of the hull are to be overall examined, including an overall and Close-up Survey of those suspect areas which were identified at the previous surveys.
Areas of substantial corrosion identified at previous surveys are to have thickness measurements taken.
Where extensive areas of corrosion are found or when considered necessary by the Surveyor, thickness measurements are to be carried out and renewals and/or repairs made when wastage exceeds allowable margins.
Where substantial corrosion is found, additional thickness measurements in accordance with 7-3-2/7 are to be taken to confirm the extent of substantial corrosion. These extended thickness measurements are to be carried out before the survey is credited as completed.
Note: The above requirements for suspect areas, including substantial corrosion, are not applicable to cargo tanks of oil and chemical carriers.
Where reduced scantlings on the basis of effective corrosion control have been adopted, the results of any measurements are to be evaluated based on the scantlings before reduction.
(1 July 2013) For vessels built under the IACS Common Structural Rules, the annual thickness gauging of ballast tanks may be omitted where a protective coating has been applied in accordance with the coating manufacturer's requirements and is maintained in GOOD condition.

1.1.10 Ballast Tanks and Combined Cargo/Ballast Tanks (1 July 2006)

1.1.10(a) *Vessels over 5 years of age (2010)*. Examination of the following tanks is to be carried out.

- i) Ballast tanks and combined cargo/ballast tanks other than double bottom tanks, where the following conditions have been identified at previous surveys.
 - A hard protective coating was found in POOR condition, or
 - A soft or semi-hard coating has been applied, or
 - A hard protective coating has not been applied from the time of construction.
- ii) Double bottom ballast tanks, where substantial corrosion was found within the tank, and the following conditions have been identified at previous surveys.
 - A hard protective coating was found in POOR condition, or
 - A soft or semi-hard coating has been applied, or
 - A hard protective coating has not been applied from the time of construction.

1.1.10(b) *Vessels over 15 years of age*. In addition to the requirements of 7-3-2/1.1.10(a), the following tanks are also to be examined.

- i) Ballast tanks and combined cargo/ballast tanks other than double bottom tanks in way of spaces designated for the carriage of cargo, where FAIR coating conditions were identified at previous surveys, a minimum of three (3) so identified tanks, i.e., one (1) forward, one (1) midship and one (1) aft.
- ii) Peak tanks, where FAIR coating conditions were identified at previous surveys.

Where extensive areas of corrosion are found or when considered necessary by the Surveyor, thickness measurements are to be carried out and renewals and/or repairs made when wastage exceeds allowable margins.

Where substantial corrosion is found, additional thickness measurements in accordance with 7-3-2/7 are to be taken to confirm the extent of substantial corrosion. These extended thickness measurements are to be carried out before the survey is credited as completed.

Where reduced scantlings on the basis of effective corrosion control have been adopted, the results of any measurements are to be evaluated based on the scantlings before reduction.

1.1.11 Helicopter Deck (1 July 2006)

Where areas of the vessel are designated for helicopter operations, the helicopter deck, deck supporting structure, deck surface, deck drainage, tie downs, markings, lighting, wind indicator, securing arrangements where fitted safety netting or equivalent, access arrangements including emergency escape, and access for fire fighting and rescue personnel, are to be examined.

1.1.12 Vessels Constructed of Aluminum Alloys (1 July 2013)

In addition to the applicable requirements of 7-3-2/1.1, the Annual Survey – Hull is to include the following:

All parts liable to rapid deterioration, particularly areas adjacent to dissimilar metals which are in close proximity.

In lieu of 7-3-2/1.1.10, internal structure of a randomly selected cargo space, dry or liquid, together with any other space deemed necessary by the Surveyor, with particular attention to be given to bilges and drain wells.

1.1.13 Vessels Constructed of Reinforced Plastic

In addition to the applicable requirements of 7-3-2/1.1, the Annual Survey – Hull is to include the following:

1.1.13(a) All accessible parts particularly liable to rapid deterioration.

1.1.13(b) The deck-to-hull connection, and superstructure and deckhouse connections to the deck.

1.1.14 Special Load Lines

Where vessels have timber, tanker or special load lines, the structural arrangements, fitting and appliances upon which such load lines are conditional, are to be examined and placed in satisfactory condition.

1.1.15 Vessels in Lightering Service (1 July 2004)

In addition to the applicable requirements of 7-3-2/1.1, the Annual Survey – Hull is also to include an external examination of hull structures where fenders for lightering operation were located. Where extensive areas of wastage are found, or when considered necessary by the Surveyor, thickness measurements and internal examination, including Close-up Survey, may be required.

1.1.16 Non Self Propelled Vessels (2005)

Machinery items installed consistent with the services of the vessel are subject to a general examination and are to be placed in satisfactory condition.

1.3 Accommodation Barges

In addition to the applicable requirements of 7-3-2/1.1, the Annual Survey – Hull is to include the following:

- The exposed parts of the hull, the deck, deck structures attached to the deck, including supporting structure, accessible internal spaces and equipment, which are to be generally examined and placed in satisfactory condition, as found necessary.
- Fire extinguishing apparatus, as outlined in Section 3 of the *ABS Guide for Building and Classing Accommodation Barges*.
- Lifesaving appliances and equipment, as outlined in Section 4 of the *ABS Guide for Building and Classing Accommodation Barges*.
- Radio communication, as outlined in the Section 5 of the *ABS Guide for Building and Classing Accommodation Barges*.

1.5 Barges

In addition to the applicable requirements of 7-3-2/1.1, the Annual Survey is to include the following:

1.5.1 Barges Engaged in Dry Bulk Cargo Trade

For barges engaged in the dry bulk cargo trade, at each Annual Survey after Special Periodical Survey No. 3, the holds, with particular attention being paid to tank tops, underside of main deck and side shell plating, framing and attachments. Thickness measurements may be required and access is to be provided for inaccessible areas, as considered necessary by attending Surveyor.

1.5.2 Manned Barges

For manned barges, the Annual Survey is to include the following:

- Fire safety measures.
- Fire extinguishers.
- Power supply including emergency source of power.
- Lifesaving appliances and equipment.
- Radio communication installation.
- Windlass, anchors and chains.
- Firemain, pressurized to the working pressure and surveyed over their full length, where accessible.

1.5.3 (2006)

For barges of Integrated Tug-Barge (ITB) combination, Annual Survey is also to include the following, as applicable, to be examined.

- Confirmation of satisfactory operation of tug-barge connection/disconnection system in line with operational manual/procedure
- Linkage and/or structural connection between tug and barge including supporting structure
- Hydraulic system, if fitted, to be checked for leaks
- Hinge arms
- Locking/unlocking device including functional test as far as practicable

1.7 Bulk Carriers – Non Double Skin ESP and Bulk Carrier Features of Combination Carriers – Non Double Skin ESP

In addition to the applicable requirements of 7-3-2/1.1, the Annual Survey is to include the following:

1.7.1 Weather Decks, Hatch Covers and Coamings (1 July 2008)

1.7.1(a) Confirmation is to be obtained that no unapproved changes have been made to the hatch covers, hatch coamings and their securing and sealing devices since the last survey.

1.7.1(b) A thorough survey of cargo hatch covers and coamings is to be carried out in the open as well as closed positions and is to include verification of proper opening and closing operation. As a result, the hatch cover sets within the forward 25% of the ship's length and at least one additional set, such that all sets on the ship are assessed at least once in every 5-year period, are to be surveyed open, closed, and in operation to the full extent on each direction at each Annual Survey, including:

- Stowage and securing in open condition
- Proper fit and efficiency of sealing in closed condition
- Operational testing of hydraulic and power components, wires, chains, and link drives

The closing of the covers is to include the fastening of all peripheral, and cross joint cleats or other securing devices. Particular attention is to be paid to the condition of the hatch covers in the forward 25% of the ship's length, where sea loads are normally greatest.

1.7.1(c) If there are indications of difficulty in operating and securing hatch covers, additional sets above those required by 7-3-2/1.7.1(b), at the discretion of the Surveyor, are to be tested in operation.

1.7.1(d) Where the cargo hatch securing system does not function properly, repairs are to be carried out under the supervision of the Surveyor.

1.7.1(e) For each cargo hatch cover set, at each Annual Survey, the following items are to be surveyed:

- Cover panels, including side plates, and stiffener attachments that may be accessible in the open position by close-up survey (for corrosion, cracks, deformation)
- Sealing arrangements of perimeter and cross joints (gaskets for condition and permanent deformation, flexible seals on combination carriers, gasket lips, compression bars, drainage channels and non return valves)
- Clamping devices, retaining bars, and cleating (for wastage, adjustment, and condition of rubber components)
- Closed cover locating devices (for distortion and attachment)
- Chain or rope pulleys
- Guides
- Guide rails and track wheels

- Stoppers
- Wires, chains, tensioners, and gypsies
- Hydraulic system, electrical safety devices and interlocks
- End and interpanel hinges, pins and stools where fitted.

1.7.1(f) At each hatchway, at each Annual Survey, the coamings, with panel stiffeners and brackets are to be checked for corrosion, cracks and deformation, especially of the coaming tops, including close-up survey.

1.7.1(g) Where considered necessary, the effectiveness of sealing arrangements may be proved by hose or chalk testing supplemented by dimensional measurements of seal compressing components.

1.7.1(h) Where portable covers or wooden or steel pontoons are fitted, checking the satisfactory condition, where applicable, of:

- Wooden covers and portable beams, carriers or sockets for the portable beam, and their securing devices
- Steel pontoons
- Tarpaulins
- Cleats, battens and wedges
- Hatch securing bars and their securing devices
- Loading pads/bars and the side plate edge
- Guide plates and chocks
- Compression bars, drainage channels and drain pipes (if any)

1.7.1(i) Examination of flame screens on vents to all bunker tanks.

1.7.1(j) Examination of air pipes, vent piping systems and ventilators including closing devices where fitted.

1.7.2 Cargo Holds

1.7.2(a) For Vessels 10 < Age ≤ 15 years:

- Overall Survey (1999).* An Overall Survey is to be carried out in all of the holds, particular attention being paid to tank tops, transverse watertight bulkheads, stool structure (externally), piping and penetrations, side plating, framing and attachment.
- Close-up Survey.* Close-up Survey of sufficient extent, minimum 25% of frames, to establish the condition of the lower region of the shell frames including approx. lower one third length of side frame at side shell and side frame end attachment and the adjacent shell plating in the forward cargo hold.

(2003) Where repairs are found necessary or where deemed necessary by the Surveyor as a result of the Overall and/or Close-up Survey, the survey is to be extended to include a Close-up Survey of all of the shell frames and adjacent shell plating of those cargo holds as well as a Close-up Survey of a sufficient extent of all remaining cargo holds.

- Thickness Measurement (1 July 2013).* Where extensive areas of corrosion are found or when considered necessary by the Surveyor, thickness measurements are to be carried out. Where substantial corrosion is found, additional thickness measurements in accordance with the requirements of 7-3-2/7 are to be taken to confirm the extent of substantial corrosion. These extended thickness measurements are to be carried out before the survey is credited as completed.

For vessels built under the IACS Common Structural Rules, the annual thickness gauging may be omitted where a protective coating has been applied in accordance with the coating manufacturer's requirements and is maintained in GOOD condition.

- Piping and Penetrations (1 July 2008).* All piping and penetrations in cargo holds, including overboard piping, are to be examined.

1.7.2(b) For Vessels Age > 15 years:

- i) *Overall Survey (1999)*. An Overall Survey is to be carried out in all of the holds, particular attention being paid to tank tops, transverse watertight bulkheads, stool structure (externally), piping and penetrations, side plating, framing and attachment.
- ii) *Close-up Survey*. Close-up examination of a sufficient extent, with a minimum 25% of the frames, to establish the condition of the lower region of the shell frames including approx. lower one third length of side frame at side shell and side frame end attachment and the adjacent shell plating in the forward cargo hold and one (1) other selected hold.

(2003) Where repairs are found necessary or where deemed necessary by the Surveyor, as a result of the Overall and/or Close-up Survey, the survey is to be extended to include a Close-up Survey of all of the shell frames and adjacent shell plating of those cargo holds as well as a Close-up Survey of sufficient extent of all remaining cargo holds.

- iii) *Thickness Measurement (1 July 2013)*. Where extensive areas of corrosion are found or when considered necessary by the Surveyor, thickness measurements are to be carried out. Where substantial corrosion is found, additional thickness measurements in accordance with the requirements of 7-3-2/7 are to be taken to confirm the extent of substantial corrosion. These extended thickness measurements are to be carried out before the survey is credited as completed.

For vessels built under the IACS Common Structural Rules, the annual thickness gauging may be omitted where a protective coating has been applied in accordance with the coating manufacturer's requirements and is maintained in GOOD condition.

- iv) (1 July 2006) All piping and penetrations in cargo holds, including overboard piping, are to be examined.

1.7.2(c) For Vessels Age > 25 years and over 100,000 DWT: (13 November 2007)

- i) *Overall Survey*. An Overall Survey is to be carried out in all of the holds, particular attention being paid to tank tops, transverse watertight bulkheads, stool structure (externally), piping and penetrations, side plating, framing and attachment.
- ii) *Close-up Survey*. Close-up examination of a sufficient extent, with a minimum 25% of the frames, to establish the condition of the lower region of the shell frames including approx. lower one third length of side frame at side shell and side frame end attachment and the adjacent shell plating in all cargo holds.

Where repairs are found necessary or where deemed necessary by the Surveyor, as a result of the Overall and/or Close-up Survey, the survey is to be extended to include a Close-up Survey of all of the shell frames and adjacent shell plating of those cargo holds as well as a Close-up Survey of sufficient extent of all remaining cargo holds.

- iii) *Thickness Measurement*. Where extensive areas of corrosion are found or when considered necessary by the Surveyor, thickness measurements are to be carried out. Where substantial corrosion is found, additional thickness measurements in accordance with the requirements of 7-3-2/7 are to be taken to confirm the extent of substantial corrosion. These extended thickness measurements are to be carried out before the survey is credited as completed.

- iv) All piping and penetrations in cargo holds, including overboard piping, are to be examined.

1.7.3 Vessels Subject to SOLAS XII/9.1 and 9.2 (1 July 2012)

In addition to the applicable requirements of 7-3-2/1.1 and 7-3-2/1.7, the Annual Survey is also to include functional examinations of the bilge well alarms to all cargo holds and conveyor tunnels, as well as the following for the foremost cargo hold:

1.7.3(a) For Vessels $5 < \text{Age} \leq 15$ years:

- i) *Overall Survey*. An Overall Survey is to be carried out, particular attention being paid to tank tops, transverse watertight bulkheads, stool structure (externally), piping and penetrations, side plating, framing and attachment.

- ii) *Close-up Survey (1 July 2006)*. Close-up examination of a sufficient extent, with a minimum 25% of the frames, to establish the condition of shell frames including their upper and lower end attachments, adjacent shell plating and transverse bulkheads.
Suspect areas identified at previous surveys are to be examined.
- iii) Where deemed necessary by the Surveyor, as a result of the Overall and Close-up Survey, the survey is to be extended to include a Close-up Survey of all of the shell frames and adjacent shell plating of the cargo hold
- iv) *Thickness Measurement (1 July 2006)*. Thickness measurements are to be carried out to an extent sufficient to determine both general and local corrosion levels at areas subject to close-up survey. The minimum requirements for thickness measurements are the suspect areas identified at previous surveys.
Where substantial corrosion is found, additional thickness measurements are to be carried out in accordance with the requirements of 7-3-2/7.
- v) *(1 July 2006)* Thickness measurements may be dispensed with, provided the Surveyor is satisfied by the Close-up Survey that there is no structural diminution and the hard protective coating, where fitted, remains effective.
- vi) *(1 July 2006)* Where the hard protective coating is found to be in GOOD condition, the extent of Close-up Surveys and thickness measurements may be specially considered.

1.7.3(b) *For Vessels Age > 15 years:*

- i) *Overall Survey*. An Overall Survey is to be carried out, particular attention being paid to tank tops, transverse watertight bulkheads, stool structure (externally), piping and penetrations, side plating, framing and attachment.
- ii) *Close-up Survey (1 July 2006)*. Close-up examination is to be carried out to establish the condition of all shell frames including their upper and lower end attachments, adjacent shell plating and transverse bulkheads.
Suspect areas identified at previous surveys are to be examined.
- iii) *Thickness Measurement (1 July 2006)*. Thickness measurements are to be carried out to an extent sufficient to determine both general and local corrosion levels at areas subject to close-up survey. The minimum requirements for thickness measurements are the suspect areas identified at previous surveys.
Where substantial corrosion is found, additional thickness measurements are to be carried out in accordance with the requirements of 7-3-2/7.
- iv) *(1 July 2006)* Thickness measurements may be dispensed with provided the Surveyor is satisfied by the Close-up Survey that there is no structural diminution and the hard protective coating, where fitted, remains effective.
- v) *(1 July 2006)* Where the hard protective coating is found to be in GOOD condition, the extent of Close-up Surveys and thickness measurements may be specially considered.

1.7.4 Bulk Carriers Subject to SOLAS XII/12 and XII/13 (2007)

1.7.4(a) *Vessels complying with SOLAS XII/12*. Water ingress detection and alarm systems for cargo holds, ballast and dry spaces are to be examined and tested at random.

1.7.4(b) *Vessels complying with SOLAS XII/13*. Means for draining and pumping of tanks forward of the collision bulkhead and bilges of dry spaces any part of which extends forward of the foremost cargo hold, and their controls are to be examined and tested.

1.9 High Speed Craft

1.9.1

For High Speed Craft of Fiber Reinforced Plastic (FRP) Construction, in addition to the applicable requirements of 7-3-2/1.1, the Annual Survey – Hull is to include the following:

- i) The craft is to be placed in drydock or slipway and all applicable items of the Annual Survey – Hull are to be examined.
- ii) The deck-to-hull connection, and superstructure and deckhouse connections are to be examined.
- iii) The vessel is to be thoroughly checked and sounded for any apparent delaminations. Where it is thought a delamination is found, a 2 inch diameter plug is to be removed from the area and examined for core to skin adhesion and water permeation.

1.9.2 (1 July 2005)

For High Speed Craft subject to the IMO HSC Code, in addition to the applicable requirements of 7-3-2/1.1, drydocking survey is to be a part of the Annual Survey as required by 7-2-1/11.7.

1.11 Passenger Vessels

In addition to the applicable requirements of 7-3-2/1.1, the Annual Survey is to include the following:

1.11.1

All shell connections below the bulkhead deck.

1.11.2 (2005)

Gangways, cargo and fueling ports, chutes and other openings in the side shell plating.

1.11.3 (2005)

Portlights including deadlights and securing arrangements below the first deck above the bulkhead deck.

1.11.4

All openings and their closures in watertight bulkheads below the bulkhead deck including watertight doors and operation of same.

1.11.5 (1 July 2005)

For passenger vessels subject to SOLAS, drydocking survey is to be a part of the Annual Survey as required by 7-2-1/11.7.

1.13 Tankers – (ESP and Non ESP) and Tank Barges and Oil Carrier Features of Combination Carriers

(1 July 2005) For Tankers (ESP and Non ESP) and Tank Barges, in addition to the applicable requirements of 7-3-2/1.1, the Annual Survey is to include the following:

1.13.1 Cargo Tanks

Cargo tank openings including gaskets, covers and coamings.

Pressure/vacuum relief valves, flame arrestors and flame screens. Tank vent protective devices are to be examined externally for proper assembly and installation, damage, deterioration or traces of carryover at the outlet. Where deemed suspect, the tank protective device is to be opened for examination.

1.13.2 Cargo and Other Piping Systems (1 July 2008)

Cargo, crude oil washing, bunker, ballast, steam, and tank vent piping systems above the weather deck and in the cargo pump room and pipe tunnels. Where suspect, piping may be required to be pressure-tested at the working pressure, thickness measured or both.

Cargo and stripping pumps including foundations, gland seals, operation of remote control and shut-down devices.

Confirmation that cargo discharge pressure gauges and level indicator systems are operational.

1.13.3 Electrical Bonding and Equipment

Electrical bonding arrangements on the weather deck and in cargo pump rooms, including bonding straps, where fitted, of cargo piping systems carrying flammable liquids and piping systems routed through hazardous areas. Bonding of cargo tanks to hull, where applicable, is to be examined.

Confirmation that electrical equipment in hazardous locations, including the cargo pump room, has been properly maintained, including the following items. The list required by SVR 4-8-1/5.3.2 may be referred to during the confirmation.

- Intrinsically safe and explosion-proof features of electrical equipment installed in the hazardous areas, in particular any associated sealing arrangement.
- The physical condition of cables (wiring) and fixtures and test of insulation resistance of the circuits. In cases where a proper record of testing is maintained, consideration may be given to accepting recent readings.
- The cable supports and the means of cable protection from mechanical damage, as originally provided.
- Gas detection system in the cargo pump room, if fitted.
- Temperature-sensing devices fitted on bulkhead shaft glands, pump bearings and casings.

1.13.4 Cargo Pump Room (2017)

Examination of pump room bulkheads for signs of leakage or fractures and, in particular, the sealing arrangement of all penetrations of bulkheads.

Confirmation that there are no potential sources of ignition in or near the cargo pump room and cargo area and that pump room access ladders are in good condition.

Operation of pump room bilge pumping system.

Pump room ventilation system including ducting, dampers and screens.

Visual examination of the cargo piping system including valves and fittings.

Verification that bolts on the cargo pumps and associated fittings, such as pedestal fixing bolts, pump casing bolts and bolts securing shaft guards are secure.

1.13.5 Oil Tank Barges (1 July 2008)

Environmental Control of Hold Spaces. Where fitted, inert gas systems, including indicators and alarms, are to be confirmed in satisfactory operating condition. Means for prevention of backflow of cargo vapor into gas-safe spaces is to be confirmed in satisfactory operating condition.

1.13.6 Tankers ESP – Ballast Tanks and Combined Cargo/Ballast Tanks (1 July 2013)

For vessels over 5 years of age, ballast tanks or combined cargo/ballast tanks are to be examined where the following conditions have been identified at previous surveys.

- i) A hard protective coating has not been applied from the time of construction, or
- ii) Soft or semi-hard coating has been applied, or
- iii) Substantial corrosion was found within the tank, or
- iv) The hard protective coating was found to be in less than GOOD condition and the hard protective coating was not repaired to the satisfaction of the Surveyor.

When considered necessary by the Surveyor, or when extensive corrosion exists, thickness measurements are to be carried out and if the results of these thickness measurements indicate that substantial corrosion is found, the extent of thickness measurements is to be increased in accordance with 7-3-2/7.

These extended thickness measurements are to be carried out before the survey is credited as completed. Suspect areas identified at previous surveys are to be examined. Areas of substantial corrosion identified at previous surveys are to have thickness measurements taken.

For vessels built under IACS Common Structural Rules, the identified substantial corrosion areas are required to be examined and additional thickness measurements are to be carried out.

1.13.7 Chemical Carriers and Chemical Tank Barges (1 July 2005)

In addition to the applicable requirements of 7-3-2/1.13.1 through 1.13.6, the Annual Survey is to include the following:

1.13.7(a) Accommodation Spaces. Verify gas and vapor tightness of doors and airports.

1.13.7(b) Cargo Pump Rooms. Verify unrestricted passage from floor and ladder platforms in the pump room as well as unrestricted access to cargo handling systems. Hoisting arrangements are to be examined.

1.13.7(c) Cargo Handling Piping and Machinery. All piping, cargo hoses, emergency shutdown valves, remote operating valves, machinery and equipment for loading, unloading, venting, heating/cooling or otherwise handling chemicals are to be examined. Pump pressure gauges are to be examined.

(1 July 2006) Cargo hoses are to be verified, where appropriate, type-approved or marked with date of testing.

See also 7-3-2/1.13.3.

1.13.7(d) Ventilating Systems. Those systems for all spaces in the cargo area, including air locks, cargo pump rooms, cargo control rooms and spaces used for cargo handling operations are to be examined. Closing devices of all air intakes and openings into the accommodation service and control spaces are to be examined. All portable ventilating equipment required for use in the cargo area is to be examined.

1.13.7(e) Cargo Tank Vent System (1 July 2006). The venting system including pressure/ vacuum valves, secondary means to prevent over or under pressure, flame screens, liquid-level indicators and alarms for the cargo tanks, as required, are to be confirmed in satisfactory operating condition. Vent line drainage arrangement is to be examined.

1.13.7(f) Environmental Control of Vapor Space in Cargo Tanks and Void Spaces Surrounding Such Tanks. Where a controlled atmosphere is required, an examination of the control provided and verification that an adequate supply of the specified medium is onboard or can be produced onboard, as required.

1.13.7(g) Pump and Pipeline Identification. Verification of pipe and pump markings.

1.13.7(h) Vapor Detection. Verify, as required, the means provided for detection and testing for toxic and flammable vapor concentrations including proper working conditions.

1.13.7(i) Personnel Protection. Firemen's outfits, protective clothing and respiratory protection equipment are to be examined. Decontamination showers and eye wash are to be examined and operationally tested as far as practicable.

1.13.7(j) Operating Instructions. Instructions and information material, such as cargo handling plans, loading manual and filling limit information, are to be verified as being aboard the vessel.

1.13.7(k) Fire Protection and Fire Extinguishing Equipment. The fire main equipment, water spray equipment, dry chemical powder fire extinguishing systems in the cargo area, and fixed inerting and fixed smothering installations are to be examined and operationally tested in so far as practicable.

1.13.8 Liquefied Gas Carriers and Liquefied Gas Tank Barges (1 July 2013)

In addition to the applicable requirements of 7-3-2/1.13.1 through 1.13.6, the Annual Survey is to include the following:

- i) *General (1 July 2003)*. The logbooks are to be examined with regard to correct functioning of the cargo containment and cargo handling systems. The hours per day of the reliquefaction plants or the boil-off rate is to be considered.
- ii) *Interbarrier Space Venting System*. The venting system or other arrangements provided for the emergency removal of gas from the interbarrier spaces (i.e., between the primary and secondary barriers) is to be confirmed in satisfactory condition.
- iii) *Cargo Tank Venting System (1 July 2003)*. The venting system for the cargo tanks and hold spaces is to be confirmed in satisfactory operating condition. The vent line drainage arrangement is to be examined.
- iv) *Instrumentation and Safety Systems (1 July 2003)*. Gas leakage detection equipment, including indicators and alarms, is to be confirmed in satisfactory operating conditions. Systems for temperature, pressure and liquid level indication of the cargo, cargo tank, insulation, the hull adjacent to the cargo containment system, and cargo refrigerating installations where fitted, including alarms, are to be confirmed in satisfactory operating condition. The piping of the gas detection system is to be visually examined for corrosion and damage and the integrity of the line between suction points and analyzing units is to be confirmed as far as possible.
(1 July 2006) The logbooks are to be examined for confirmation that the emergency shutdown system has been tested.
- v) *Environmental Control of Hold Spaces (1 July 2008)*. Inert gas and dry air systems, including indicators and alarms, are to be confirmed in satisfactory operating condition. Means for prevention of backflow of cargo vapor into gas-safe spaces is to be confirmed in satisfactory operating condition. For membrane containment systems, normal operation of the nitrogen control system for insulation and interbarrier spaces shall be confirmed.
- vi) *Cargo Handling Piping and Machinery (1998)*. All piping, cargo hoses, emergency shut-down valves, remote operating valves, machinery and equipment for loading, unloading, venting, compressing, refrigerating, liquefying, heating or otherwise handling the liquefied gas or vapor is to be examined, as far as possible. Stopping of the cargo pumps and compressors upon emergency shut-down of the system is to be confirmed.
(1 July 2006) Cargo hoses are to be verified, where appropriate, type-approved or marked with date of testing.
See also 7-3-2/1.13.2.
- vii) *Cargo Tank Tightness*. The tightness of cargo tanks is to be confirmed. For this purpose, the vessel's gas leak detectors, micro-flow meters, etc. may be utilized providing that they are first proved to be in good order. The vessel's logbooks are also to be reviewed to confirm the tightness of the cargo tanks.
- viii) *Heating Coils*. Heating coils and other heating systems which are fitted and essential for the heating of the hull structure to ensure that the temperature of the structure does not fall below the minimum allowable value for the material used are to be proven in satisfactory operating condition.
- ix) *Ventilating System (1 July 2006)*. Examination of the ventilation system is to be made for all gas dangerous spaces and zones, including air locks, cargo pump rooms, cargo compressor rooms, cargo control rooms and spaces used for cargo handling operations. All portable ventilating equipment required for use in the gas dangerous spaces is to be examined. Provision of spares for mechanical ventilation fans for gas dangerous spaces and zones, recommended by manufacturer is to be confirmed.

- x) *Spaces in Cargo Areas (1 July 2003)*. Air locks, cargo pump rooms, cargo compressor rooms, rooms containing electric motors for driving cargo pumps or compressors, cargo control rooms and spaces used for cargo handling operations are to be examined. All accessible gas-tight bulkhead penetrations including gas-tight shaft seals are to be examined. The means for accomplishing gas tightness of the wheelhouse doors and windows is to be examined.
- (1 July 2006) The closing devices for all air intakes and openings into accommodation spaces, service spaces, machinery spaces, control stations and openings in superstructures and deckhouses facing the cargo area or bow and stern loading/unloading arrangements are to be examined.
- All windows and sidescuttles within the area required to be of the fixed type (non-opening) are to be examined for gas tightness.
- xi) *Drip Trays*. Portable and fixed drip trays and insulation for the protection of the deck in the event of cargo leakage are to be examined.
- xii) *Gas Burning Installations (1 July 2006)*. Gas burning installations, including instrumentation and safety systems, are to be examined and confirmed in satisfactory operating condition. See also 7-3-2/1.13.8iv).
- xiii) *Sealing Arrangements*. Sealing arrangements on the weather deck in way of openings for the cargo containment system are to be examined.
- xiv) *Fire Protection and Fire Extinguishing Equipment*. The fire water main equipment, water spray equipment, dry chemical powder fire extinguishing systems in the cargo area, and fixed inerting and fixed smothering installations in gas-dangerous spaces are to be examined and operationally tested, as far as practicable.
- xv) *Electrical Equipment (2007)*. Electrical equipment in gas-dangerous spaces or zones is to be examined as far as practicable with particular respect to the following:
- Protective earthing
 - Physical condition of electrical cables and supports
 - Integrity of enclosures
 - Intrinsically safe, explosion proof, or increased safety features of electrical equipment
 - Functional testing of pressurized equipment and associated alarms
 - Testing systems for de-energizing electrical equipment which is not certified safe for use in gas-hazardous areas but which is located in spaces protected by air-locks (e.g., electrical motor rooms or cargo control rooms)
 - Insulation resistance readings of circuits. Where a proper record of testing is maintained, consideration may be given to accepting recent readings.
- Note:* See also IACS Recommendation No.35 – Inspection and maintenance of electrical equipment installed in hazardous areas.
- xvi) *Personnel Protection*. Firemen's outfits, protective clothing, and respiratory protection equipment are to be examined. Decontamination showers and eye wash are to be examined and operationally tested, as far as practicable.
- xvii) *Tightness of Hull*. Means for detecting leakage into the hold space through the ship's structure forming the boundary of the hold space are to be examined.
- xviii) *Operating Instructions*. Instructions and information material, such as cargo handling plans, loading manual, filling limit information, cooling-down procedure, are to be confirmed as being aboard the vessel.
- xix) *Relief Valves (1999)*. All relief valves in the cargo containment and venting system are to be examined, including protective screens and flame screens, if provided, and seals confirmed intact. Records of opening and closing pressures of relief valves are to be confirmed onboard.

1.13.9 Access to Bow on Tankers (1 July 2006)

For tankers including oil carriers, chemical carriers and gas carriers, arrangements for safe access to the bow are to be examined.

1.13.10 Emergency Towing Arrangements (1 July 2006)

For tankers of 20,000 tonnes deadweight and above including oil carriers, chemical carriers and gas carriers, emergency towing arrangements are to be examined.

1.15 General Dry Cargo Vessels (ESDC) (2004)

In addition to the applicable requirements of 7-3-2/1.1, the Annual Survey – Hull is also to include the following:

1.15.1 Weather Decks, Hatch Covers and Coamings (1 July 2006)

1.15.1(a) Confirmation is to be obtained that no unapproved changes have been made to the hatch covers, hatch coamings and their securing and sealing devices since the last survey.

1.15.1(b) Where mechanically operated steel covers are fitted, checking the satisfactory condition of:

- Hatch covers; including close-up survey of hatch cover plating
- Tightness devices of longitudinal, transverse and intermediate cross junctions (gaskets, gasket lips, compression bars, drainage channels)
- Clamping devices, retaining bars, cleating
- Chain or rope pulleys
- Guides
- Guide rails and track wheels
- Stoppers, etc.
- Wires, chains, gypsies, tensioning devices
- Hydraulic system essential to closing and securing
- Safety locks and retaining devices

1.15.1(c) Where portable covers, wooden or steel pontoons are fitted, checking the satisfactory condition, where applicable, of:

- Wooden covers and portable beams, carriers or sockets for the portable beam, and their securing devices
- Steel pontoons
- Tarpaulins
- Cleats, battens and wedges
- Hatch securing bars and their securing devices
- Loading pads/bars and the side plate edge
- Guide plates and chocks
- Compression bars, drainage channels and drain pipes (if any)

1.15.1(d) Checking the satisfactory condition of hatch coaming plating and their stiffeners including close-up survey.

1.15.1(e) Random checking of the satisfactory operation of mechanically operated hatch covers is to be made including:

- Stowage and securing in open condition
- Proper fit and efficiency of sealing in closed condition
- Operational testing of hydraulic and power components, wires, chains, and link drives

1.15.2 Cargo Holds

1.15.2(a) For Vessels $10 < \text{Age} \leq 15$ Years

- i) Overall Survey of one (1) forward and one (1) after cargo hold and their associated tween deck spaces.
- ii) When considered necessary by the Surveyor, or where extensive corrosion exists, thickness measurement is to be carried out. Where substantial corrosion is found, additional thickness measurements, in accordance with 7-3-2/7, are to be taken to confirm the extent of substantial corrosion.

(1 July 2006) These extended thickness measurements are to be carried out before the survey is credited as completed.

1.15.2(b) For Vessels Age > 15 Years

- i) Overall Survey of all cargo holds and tween deck spaces.
- ii) Close-up examination of a sufficient extent, with a minimum 25% of the frames, to establish the condition of the lower region of the shell frames, including approximately the lower one third length of side frame at side shell and side frame end attachment and the adjacent shell plating in a forward lower cargo hold and one (1) other selected lower cargo hold. Where this level of survey reveals the need for remedial measures, the survey is to be extended to include a Close-up Survey of all of the shell frames and adjacent shell plating of those cargo holds and associated tween deck spaces (as applicable) as well as a Close-up Survey of a sufficient extent of all remaining cargo holds and tween deck spaces (as applicable).

Where the hard protective coating in cargo holds, as applicable, is found to be in a GOOD condition, the extent of Close-up Surveys may be specially considered.

- iii) When considered necessary by the Surveyor, or where extensive corrosion exists, thickness measurement is to be carried out. Where substantial corrosion is found, additional thickness measurements, in accordance with 7-3-2/7, are to be taken to confirm the extent of substantial corrosion.

(1 July 2006) These extended thickness measurements are to be carried out before the survey is credited as completed.

- iv) All piping and penetrations in cargo holds, including overboard piping, are to be examined.

1.15.3 (1 July 2007)

For ships complying with the requirements for single hold cargo ships subject to SOLAS II-I/23-3 and II-I/25 for hold water level detectors, the annual survey is to include an examination and a test, at random, of the water ingress detection system and of their alarms.

1.17 Vessels Carrying Vehicles (2012)

In addition to the applicable requirements of 7-3-2/1.1, the Annual Survey – Hull is also to include the following:

1.17.1 Bow Doors, Inner Doors, Side Shell Doors and Stern Doors

1.17.1(a) The survey is to consist of an examination to verify, as far as practicable, that the bow, inner, side and stern doors are maintained in satisfactory condition.

1.17.1(b) Confirmation is to be obtained that no unapproved changes have been made to the bow, inner, side shell and stern doors since the last survey.

1.17.1(c) Bow doors, inner doors, side shell doors and stern doors are to be examined together with shell plating surrounding the opening and the securing, supporting and locking devices, with particular attention being paid to:

- i) Plating, stiffening and welding of same. The following devices and fittings and associated welding are subject to close-up survey by the attending Surveyor:
- Cylinder securing pins, supporting brackets, back-up brackets (where fitted) and their welded connections
 - Hinge pins, supporting brackets, back-up brackets (where fitted) and their welded connections
 - Locking hooks, securing pins, supporting brackets, back-up brackets (where fitted) and their welded connections
 - Locking pins, supporting brackets, back-up brackets (where fitted) and their welded connections
 - Locating and stopper devices and their welded connections
- ii) Supporting structure, supports and lifting arms
- iii) Hinging arms and their welding
- iv) Secondary stiffeners and welding
- v) Hinges, bearings and thrust bearings
- Clearances are to be measured. Clearances of hinges, bearings and thrust bearings are to be taken, where no dismantling is required. Where the function test is not satisfactory, dismantling may be required to measure the clearances. If dismantling is carried out, a visual examination of hinge pins and bearings together with NDT of the hinge pin is to be carried out. Clearances of securing, supporting and locking devices are to be measured, where indicated in the Operating and Maintenance Manual (OMM).
- Where clearances cannot be measured without dismantling, they are to be measured, at least, at the Special Periodical Survey and where the function test is not satisfactory
- vi) Securing, supporting and locking devices
- Clearances are to be measured
- Where clearances cannot be measured without dismantling, they are to be measured, at least, at the Special Periodical Survey and where the function test is not satisfactory
- Nondestructive Testing is to be carried out as per the requirement of the Operation and Maintenance Manual.
 - Thickness is to be measured as per the requirement of the Operation and Maintenance Manual.
- vii) Where fractures are revealed, a thorough examination, supported by Nondestructive Testing, is to be carried out in the surrounding area and for similar items.
- viii) Sealing arrangement. An examination of packing material/ rubber gaskets and retaining bars or channels, including welding is to be carried out.
- ix) Drainage arrangement

1.17.1(d) Tightness test of the sealing arrangements is to be tested by hose test or equivalent. If the visual examination and function test have shown satisfactory results, the tightness test of shell doors on Ro-Ro cargo ships need not be carried out unless considered necessary by the attending surveyor.

1.17.1(e) Operating procedures for closing and securing doors is to be verified onboard and posted appropriately. If an Operating and Maintenance Manual (OMM) is required, it is to be verified that an approved copy is on board and any possible modifications are included.

It is to be verified that documented operating procedures for closing and securing doors are kept on board and posted at an appropriate place.

The surveyor shall examine the OMM with special attention to the register of inspections and its contents as a basis for the survey.

1.17.1(f) Function test of doors. Checking of the satisfactory operation of the bow, inner, side shell and stern doors during a complete opening and closing operation is to be made, as applicable, including:

- Proper working of the hinging arms and hinges
- Proper engagement of the thrust bearings
- Device for locking the door in the open position
- Securing, supporting and locking devices
- Proper sequence of the interlock system for the opening/closing system and the securing and locking devices
- Mechanical lock of the securing devices
- Proper locking of hydraulic securing devices in the event of a loss of the hydraulic fluid, according to the procedure provided by the OMM
- Correct indication of open/closed position of doors and securing/locking devices at navigation bridge and other control stations
- Isolation of the hydraulic securing /locking devices from other hydraulic systems
- Confirmation that the operating panels are inaccessible to unauthorized persons.
- Verification that a notice plate giving instructions to the effect that all securing devices are to be closed and locked before leaving harbor is placed at each operating panel and supplemented by warning indicator lights.
- Examination of electrical equipment for opening, closing and securing the doors

1.17.1(g) Function test of the indicator system. Checking of the satisfactory operation of the indicator system, where fitted, is to be carried out, as applicable, including:

- Proper visible indication and audible alarm on the navigation bridge panel, according to the selected function "harbor/sea voyage" and on the operating panel
- Lamp test function on both panels
- Verification that it is not possible to turn off the indicator light on both panels
- Verification of fail safe performance, according to the procedure provided by the OMM
- Confirmation that power supply for indicator system is supplied by the emergency source or other secure power supply and independent of the power supply for operating the doors
- Proper condition of sensors and protection from water, ice formation and mechanical damage

1.17.1(h) Test of water leakage detection system. Where fitted, the water leakage detection system is to be tested including proper audible alarm on the navigation bridge panel and on the engine control room panel, according to the procedure provided by the OMM.

1.17.1(i) Test of television surveillance system. Where fitted, the television surveillance system is to be tested including proper indication on the navigation bridge monitor and on the engine control room monitor.

1.17.1(j) NDT and Thickness Measurements. When considered necessary by the surveyor, NDT and thickness measurements may be required after visual examination and function test.

1.19 Bulk Carriers – Double Skin ESP and Bulk Carrier Features of Combination Carriers – Double Skin ESP (2005)

In addition to the applicable requirements of 7-3-2/1.1, the Annual Survey is also to include the following:

1.19.1 Weather Decks, Hatch Covers and Coamings (1 July 2008)

1.19.1(a) Confirmation is to be obtained that no unapproved changes have been made to the hatch covers, hatch coamings and their securing and sealing devices since the last survey.

1.19.1(b) A thorough survey of cargo hatch covers and coamings is to be carried out in the open as well as closed positions and is to include verification of proper opening and closing operation. As a result, the hatch cover sets within the forward 25% of the ship's length and at least one additional set, such that all sets on the ship are assessed at least once in every 5-year period, are to be surveyed open, closed, and in operation to the full extent on each direction at each Annual Survey, including:

- Stowage and securing in open condition
- Proper fit and efficiency of sealing in closed condition
- Operational testing of hydraulic and power components, wires, chains, and link drives

The closing of the covers is to include the fastening of all peripheral and cross joint cleats or other securing devices. Particular attention is to be paid to the condition of the hatch covers in the forward 25% of the ship's length, where sea loads are normally greatest.

1.19.1(c) If there are indications of difficulty in operating and securing hatch covers, additional sets above those required by 7-3-2/1.19.1(b), at the discretion of the Surveyor, are to be tested in operation.

1.19.1(d) Where the cargo hatch securing system does not function properly, repairs are to be carried out under the supervision of the Surveyor.

1.19.1(e) For each cargo hatch cover set, at each Annual Survey, the following items are to be surveyed:

- Cover panels, including side plates, and stiffener attachments that may be accessible in the open position by close-up survey (for corrosion, cracks, deformation)
- Sealing arrangements of perimeter and cross joints (gaskets for condition and permanent deformation, flexible seals on combination carriers, gasket lips, compression bars, drainage channels and non return valves)
- Clamping devices, retaining bars, and cleating (for wastage, adjustment, and condition of rubber components)
- Closed cover locating devices (for distortion and attachment)
- Chain or rope pulleys
- Guides
- Guide rails and track wheels
- Stoppers
- Wires, chains, tensioners, and gypsies
- Hydraulic system, electrical safety devices and interlocks
- End and interpanel hinges, pins, and stools, where fitted.

1.19.1(f) At each hatchway, at each Annual Survey, the coamings, with panel stiffeners and brackets are to be checked for corrosion, cracks, and deformation, especially of the coaming tops, including close-up survey.

1.19.1(g) Where considered necessary, the effectiveness of sealing arrangements may be proved by hose or chalk testing supplemented by dimensional measurements of seal compressing components.

1.19.1(h) Where portable covers or wooden or steel pontoons are fitted, checking the satisfactory condition, where applicable, of:

- Wooden covers and portable beams, carriers or sockets for the portable beam, and their securing devices
- Steel pontoons, including close-up survey of hatch cover plating
- Tarpaulins
- Cleats, battens, and wedges
- Hatch securing bars and their securing devices
- Loading pads/bars and the side plate edge
- Guide plates and chocks
- Compression bars, drainage channels, and drain pipes (if any)

1.19.1(i) Examination of flame screens on vents to all bunker tanks.

1.19.1(j) Examination of air pipes, vent piping systems and ventilators including closing devices where fitted.

1.19.2 Cargo Holds

1.19.2(a) For Vessels $10 < \text{Age} \leq 15$ years:

- i) *Overall Survey.* Overall survey of two selected cargo holds, particular attention being paid to tank tops, transverse and longitudinal watertight bulkheads, and stool structure (externally).
- ii) *Thickness Measurement (1 July 2006).* When considered necessary by the Surveyor, or where extensive corrosion exists, thickness measurements are to be carried out. Where substantial corrosion is found, additional thickness measurements in accordance with the requirements of 7-3-2/7 are to be taken to confirm the extent of substantial corrosion. These extended thickness measurements are to be carried out before the survey is credited as complete.
(1 July 2013) For vessels built under IACS Common Structural Rules, the annual thickness gauging may be omitted where a protective coating has been applied in accordance with the coating manufacturer's requirements and is maintained in GOOD condition.
- iii) *Piping and Penetrations (1 July 2008).* All piping and penetrations in cargo holds, including overboard piping, are to be examined.

1.19.2(b) For Vessels $\text{Age} > 15$ years:

- i) *Overall Survey.* Overall survey of all cargo holds, particular attention being paid to tank tops, transverse and longitudinal watertight bulkheads, and stool structure (externally).
- ii) *Thickness Measurement (1 July 2006).* When considered necessary by the Surveyor, or where extensive corrosion exists, thickness measurements are to be carried out. Where substantial corrosion is found, additional thickness measurements in accordance with the requirements of 7-3-2/7 are to be taken to confirm the extent of substantial corrosion. These extended thickness measurements are to be carried out before the survey is credited as complete.
(1 July 2013) For vessels built under IACS Common Structural Rules, the annual thickness gauging may be omitted where a protective coating has been applied in accordance with the coating manufacturer's requirements and is maintained in GOOD condition.
- iii) *Piping and penetrations.* All piping and penetrations in cargo holds, including overboard piping, are to be examined.

1.19.3 Bulk Carriers Subject to SOLAS XII/12 and XII/13 (2007)

1.19.3(a) *Vessels complying with SOLAS XII/12.* Water ingress detection and alarm systems for cargo holds, ballast and dry spaces are to be examined and tested at random.

1.19.3(b) *Vessels complying with SOLAS XII/13.* Means for draining and pumping of tanks forward of the collision bulkhead and bilges of dry spaces any part of which extends forward of the foremost cargo hold, and their controls are to be examined and tested.

1.21 Compressed Natural Gas Carriers (2017)

Survey of the containment system is to be carried out in accordance with the survey inspection plan and in line with the applicable requirements of the following:

- i) *General.* The cargo carriage records are to be examined with regard to the correct functioning of the cargo containment and cargo handling systems.
- ii) *Cargo Containment System Venting.* The venting system for the cargo containment system and hold spaces is to be confirmed in satisfactory operating condition. Vent line drainage arrangement is to be examined.
- iii) *Instrumentation and Safety Systems.* Gas leakage detection equipment, including indicators and alarms, is to be confirmed in satisfactory operating conditions. Systems for temperature and pressure of the cargo, cargo containment system, insulation, the hull adjacent to the cargo containment system, and cargo refrigerating installations where fitted, including alarms, are to be confirmed in satisfactory operating condition. The piping of the gas detection system is to be visually examined for corrosion and damage and the integrity of the line between suction points and analyzing units is to be confirmed as far as possible.
- iv) *Environmental Control of Hold Spaces.* Inert gas and dry air systems, including indicators and alarms, are to be confirmed in satisfactory operating condition. Means for prevention of backflow of cargo gas into gas-safe spaces is to be confirmed in satisfactory operating condition.
- v) *Cargo Handling Piping and Machinery.* All piping, cargo hoses, emergency shut-down valves, remote operating valves, machinery and equipment for loading, unloading, venting, compressing, refrigerating, heating or otherwise handling the gas or vapor, are to be examined, as far as possible. Stopping of the cargo pumps and compressors upon emergency shutdown of the system is to be confirmed.
- vi) *Cargo Containment System Tightness.* The tightness of the cargo containment system is to be confirmed. For this purpose, the vessel's gas leak detectors, micro-flow meters, etc., may be utilized providing that they are first proved to be in good order. The vessel's cargo carriage records are also to be made available to the Surveyor so that the Surveyor may verify the tightness of the cargo containment system.
- vii) *Ventilating Systems.* Examination of the ventilation system is to be made for all spaces in the cargo area, including air locks, cargo pump rooms, cargo compressor rooms, cargo control rooms and spaces used for cargo handling operations. All portable ventilating equipment required for use in the cargo area is to be examined. Provision of spares for cargo area mechanical ventilation fans recommended by the manufacturer is to be confirmed.
- viii) *Spaces in Cargo Areas.* Air locks, cargo pump rooms, cargo compressor rooms, rooms containing electric motors for driving cargo pumps or compressors, cargo control rooms and spaces used for cargo handling operations are to be examined. All accessible gas-tight bulkhead penetrations, including gas-tight shaft seals, are to be examined. The means for accomplishing gas tightness of the wheelhouse doors and windows, and closing devices for all air intakes and openings in superstructures and deckhouse facing the cargo area or bow and stern loading/ unloading arrangements, are to be examined. All windows and sidescuttles within the area required to be of the fixed type (non-opening) are to be examined for gas tightness.
- ix) *Sealing Arrangements.* Sealing arrangements on the weather deck in way of openings for the cargo containment system are to be examined.
- x) *Fire Protection and Fire Extinguishing Equipment.* The fire water main equipment, water spray equipment, dry chemical powder fire extinguishing systems in the cargo area, and fixed inerting and fixed smothering installations in gas-dangerous spaces are to be examined and operationally tested, in so far as practicable.

- xi) *Electrical Equipment.* Electrical equipment in gas-dangerous spaces or zones is to be examined. This examination is to include the physical condition of electrical cables and supports; intrinsically safe, explosion proof or increased safety features of electrical equipment; functional testing of pressurized equipment and associated alarms; testing systems for de-energizing electrical equipment which is not certified for use in gas hazardous areas but which is located in spaces protected by airlocks (e.g., electrical motor rooms or cargo control rooms); and insulation resistance readings of circuits. Where a proper record of testing is maintained, consideration may be given to accepting recent readings.
- xii) *Electrical Bonding Arrangement.* Electrical bonding arrangements on weather deck and in cargo handling machinery rooms, including bonding straps, where fitted, of cargo piping systems carrying flammable gases and piping systems routed through hazardous areas. Bonding to hull, where applicable, of cargo containment systems is to be examined.
- xiii) *Personnel Protection.* Additional firemen's outfits, protective clothing and respiratory protection equipment are to be examined.
- xiv) *Operating Instructions.* Instructions and information material, such as cargo handling plans, loading manual, filling limit information and inerting procedure, are to be confirmed as being aboard the vessel.
- xv) *Relief Valves.* All relief valves in the cargo containment and venting system are to be examined, including protective screens and flame screens, if provided, and seals confirmed intact. Records of opening and closing pressures of relief valves are to be confirmed onboard.
- xvi) *Inerting System.* Inerting system is to be examined and tested, to include.
 - Backflow alarm into inert gas system is verified.
 - Isolation valves, non-return valves, controls, relief valves, etc., are to be tested for inerted tanks.
 - Continuous reading oxygen meter has alarm set with a maximum oxygen value of 5%.
 - Verify that a means to prevent backflow of gas is provided in the cargo area.

3 Intermediate Surveys (1 July 2014)

For vessels on Continuous Survey system, see also 7-2-1/7.

3.1 All Vessels

(1 July 2006) The scope of the second or third Annual Survey is to be extended to include the following. (See also 7-2-1/3.)

3.1.1 Survey Planning Meeting (1 July 2006)

A survey planning meeting is to be held prior to the commencement of the survey.

3.1.2 Ballast Tanks (2010)

i) For Vessels $5 < \text{Age} \leq 10$ years

Overall Survey of a minimum of three (3) representative ballast tanks selected by the Surveyor is to be carried out. Where a hard protective coating is found in POOR condition, where soft or semi-hard coating has been applied or where a hard protective coating has not been applied from time of construction, the examination is to be extended to other ballast tanks of the same type.

ii) For Vessels Age > 10 years

Overall Survey of all ballast tanks is to be carried out.

If such examinations reveal no visible structural defects, the examination may be limited to verification that the corrosion prevention system remains effective.

3.1.2(a) Ballast Tanks and Combined Cargo/Ballast Tanks Other than Double Bottom Tanks. Where provided, the condition of corrosion prevention system of ballast tanks and combined cargo/ballast tanks is to be examined.

Ballast tanks and combined cargo/ballast tanks, other than double bottom tanks, where a hard protective coating is found in POOR condition and Owners or their representatives elect not to restore the coating, where a soft or semi-hard coating has been applied or where a hard protective coating has not been applied from time of construction, the tanks in question are to be internally examined at each subsequent Annual Survey. Thickness measurements are to be carried out as considered necessary by the Surveyor.

3.1.2(b) Ballast Tanks in way of Double Bottom. Double bottom ballast tanks, where a hard protective coating is found in POOR condition and owners or their representatives elect not to restore the coating, where a soft or semi-hard coating has been applied or where a hard protective coating has not been applied from time of construction, the tanks in question are to be internally examined at each subsequent Annual Survey where substantial corrosion is documented. Thickness measurements are to be carried out as required.

3.1.3 Thickness Measurements

When extensive areas of wastage are found, thickness measurements are to be carried out and renewals made where wastage exceeds the allowable margin. Where reduced scantlings on the basis of effective corrosion control have been adopted, the results of any measurements are to be evaluated based on scantlings before reduction.

3.1.4 Tank Testing (2003)

Pressure testing of cargo and ballast tanks is not required unless deemed necessary by the attending Surveyor.

3.1.5 Vessels in Lightering Service (1 July 2004)

In addition to the applicable requirements of 7-3-2/3.1, the Intermediate Survey is to include an external examination and internal Close-up Survey of hull structures, including thickness measurements, where fenders for lightering operation were located.

3.1.6 Cargo Spaces (2012)

For vessels over 10 years of age other than ships engaged in the carriage of dry cargoes only or vessels as noted in 7-3-2/3.11, 7-3-2/3.13, 7-3-2/3.15, and 7-3-2/3.19, an internal examination of selected cargo spaces is to be carried out.

3.1.7 (1 July 2014)

In the case of dry cargo ships over 15 years of age, other than bulk carriers subject to 7-3-2/3.7 or 7-3-2/3.17 or general dry cargo ships subject to 7-3-2/3.9, an internal examination of at least two cargo holds is to be carried out.

3.3 Accommodation Barges

In addition to the applicable requirements of 7-3-2/3.1, the Intermediate Survey is to include the following:

3.3.1 Overall Survey Requirements

In lieu of 7-3-2/3.1.2, an Overall Survey of one (1) end tank and at least two (2) other representative tanks between the end bulkheads used primarily or exclusively for water ballast.

3.5 Barges

In addition to the applicable requirements of 7-3-2/3.1, the Intermediate Survey is to include the following:

3.5.1 Salt Water Ballast Spaces

In lieu of 7-3-2/3.1.2, an Overall Survey of three (3) representative salt water ballast spaces including one (1) rake tank and one (1) upper wing tank, if applicable, and one (1) additional space selected by the Surveyor.

3.5.2 Deck Cargo Barges (2007)

At each Intermediate Survey after Special Periodical Survey – Hull No. 1, in addition to the required salt water ballast spaces, at least two (2) void spaces, one (1) port and one (1) starboard, are to be examined internally. Where extensive corrosion or structural damage is found, the remaining void spaces may also be required to be examined as considered necessary by the attending Surveyor.

3.5.3 Dry Cargo Barges (2007)

At each Intermediate Survey after Special Periodical Survey – Hull No. 1, in addition to the required salt water ballast spaces, at least two (2) representative cargo holds are to be examined. Where extensive corrosion or structural damage is found, the remaining holds may also be required to be examined as considered necessary by the attending Surveyor. See 7-3-2/1.5.1.

3.5.4 Oil Tank Barges, Fuel Oil Tank Barges and Chemical Tank Barges

At each Intermediate Survey after Special Periodical Survey – Hull No. 2, in addition to the required salt water ballast spaces, at least three (3) cargo tanks: one (1) center tank, one (1) port wing tank and one (1) starboard wing tank, are to be examined internally and dealt with, as deemed necessary by the attending Surveyor. Thickness gauging and means of access to the upper part of the tanks may be required. Where extensive corrosion or structural damage is found, the remainder of the cargo tanks may be required to be examined.

3.5.5 Liquefied Gas Tank Barges (1 July 2005)

In addition to the requirements of 7-3-2/3.5.1, an Intermediate Survey is also to include the applicable requirements of 7-3-2/3.11.2.

3.7 Bulk Carriers – Non Double Skin ESP and Bulk Carrier Features of Combination Carriers – Non Double Skin ESP (1 July 2001)

In addition to the applicable requirements of 7-3-2/3.1, the Intermediate Survey is to include the following:

3.7.1 Survey Planning (1 July 2005)

Survey planning meeting is to be held in accordance with 7-3-2/9.2.

In addition, for vessels over 10 years of age, a Survey program is to be developed in accordance with 7-3-2/9.1.

3.7.2 Overall Survey Requirements (1 July 2006)

3.7.2(a) For Vessels $5 < \text{Age} \leq 10$ years

i) *Ballast tanks.* In addition to 7-3-2/3.1.2, representative ballast tanks selected by the Surveyor including fore and aft peak tanks and a number of other tanks, taking into account the total number and types of ballast tanks, are to be examined.

If such overall survey reveals no visible structural defects, the examination may be limited to verification that the corrosion prevention system remains effective.

ii) *Cargo holds.* Overall survey of all cargo holds are to be carried out.

iii) Suspect areas identified at previous surveys are to be examined.

3.7.2(b) For Vessels Age > 10 years

Overall survey requirements of the previous Special Periodical Survey as contained in 7-3-2/5.7.2 and 7-3-2/5.7.3.

Internal examination of fuel oil, lube oil and fresh water tanks in the cargo length is not required unless deemed necessary by the Surveyor.

3.7.3 Close-up Survey Requirements (1 July 2006)

3.7.3(a) For Vessels $5 < \text{Age} \leq 10$ years

- i) In the forward cargo hold and one (1) other hold of sufficient extent (at least 25% of shell frames) to establish the condition of:
 - Shell frames including their upper and lower end attachments, adjacent shell plating and transverse bulkheads including stiffening systems.
- ii) When deemed necessary by the Surveyor as a result of the Overall and Close-up Survey, the survey is to be extended to include a Close-up Survey of all shell frames and adjacent shell plating of that cargo hold and a Close-up Survey of sufficient extent of all remaining cargo holds.
- iii) Suspect areas identified at previous surveys
- iv) For areas of cargo holds where hard protective coating is found in GOOD condition, the extent of close-up survey may be specially considered.

3.7.3(b) For Vessels $\text{Age} > 10$ years

Close-up Survey requirements of the previous Special Periodical Survey as contained in 7-3-2/5.7.4.

3.7.4 Thickness Measurement Requirements (1 July 2006)

3.7.4(a) For Vessels $5 < \text{Age} \leq 10$ years

- i) Thickness measurements of sufficient extent to determine general and local corrosion levels of areas subject to Close-up Survey, any suspect areas and areas of substantial corrosion identified at previous surveys.
- ii) The extent of thickness measurements may be specially considered provided the Surveyor is satisfied by the close-up survey that there is no structural diminution and the hard protective coating is found in GOOD condition.
- iii) Where substantial corrosion is found, additional thickness measurements in accordance with 7-3-2/7 are to be taken to confirm the extent of substantial corrosion. These extended thickness measurements are to be carried out before the survey is credited as completed.

(1 July 2013) For vessels built under IACS Common Structural Rules, the identified substantial corrosion areas may be:

- a) Protected by coating applied in accordance with the coating manufacturer's requirements and examined at annual intervals to confirm the coating in way is still in GOOD condition, or alternatively
- b) Required to be measured at annual intervals.

3.7.4(b) For Vessels $\text{Age} > 10$ years

Thickness measurement requirements of the previous Special Periodical Survey as contained in 7-3-2/5.7.5.

3.7.5 Tank Testing Requirements (1 July 2006)

For Vessels $\text{Age} > 10$ years

Tank testing requirements of the previous Special Periodical Survey as contained in 7-3-2/5.7.6 may be required as deemed necessary by the Surveyor.

3.7.6 Drydocking Requirements (1 July 2006)

3.7.6(a) For Vessels $10 < \text{Age} \leq 15$ years

Drydocking requirements of the previous Special Periodical Survey as contained in 7-3-2/5.7.7 are to be carried out.

In lieu of the above, an underwater survey in lieu of drydocking (UWILD) may be considered as equivalent.

3.7.6(b) For Vessels Age > 15 years

Drydocking requirements of the previous Special Periodical Survey as contained in 7-3-2/5.7.7 are to be carried out.

3.7.7 Bulk Carriers subject to IACS Unified Requirement S31 (2004)

Side shell frames of cargo holds bounded by a single side shell are to be assessed for compliance with the requirements of IACS UR S31 and steel renewal, reinforcement or coating, where required in accordance with IACS UR S31, is to be carried out.

3.9 General Dry Cargo Vessels (ESDC) (2004)

In addition to the applicable requirements of 7-3-2/3.1, the Intermediate Survey is to include the following:

3.9.1 Survey Planning (2005)

(1 July 2006) A survey planning meeting is to be held prior to the commencement of the survey. See also 7-3-2/13.1.

For Vessels Age > 15 years

Survey planning is to be carried out in accordance with 7-3-2/10.1.

3.9.2 Overall Survey Requirements (1 July 2006)

3.9.2(a) For Vessels $5 < \text{Age} \leq 10$ years

Overall Survey of one (1) forward and one (1) after cargo hold and their associated tween deck spaces.

All suspect areas identified at previous surveys are to be examined in accordance with 7-3-2/1.1.9.

3.9.2(b) For Vessels $10 < \text{Age} \leq 15$ years

Overall Survey of all cargo holds and tween deck spaces.

All suspect areas identified at previous surveys are to be examined in accordance with 7-3-2/1.1.9.

When considered necessary by the Surveyor, or where extensive corrosion exists, thickness measurement is to be carried out.

Where substantial corrosion is found, additional thickness measurements, in accordance with 7-3-2/7, are to be taken to confirm the extent of substantial corrosion. These extended thickness measurements are to be carried out before the survey is credited as completed.

3.9.2(c) For Vessels Age > 15 years

Overall Survey requirements of the previous Special Periodical Survey as contained in 7-3-2/5.15.2 and 7-3-2/5.15.3.

Internal examination of fuel oil, lube oil and fresh water tanks in the cargo length is not required unless deemed necessary by the Surveyor.

3.9.3 Close-up Survey Requirements (1 July 2006)

For Vessels Age > 15 years

Close-up Survey requirements of the previous Special Periodical Survey as contained in 7-3-2/5.15.4.

3.9.4 Thickness Measurements Requirements (1 July 2006)

For Vessels Age > 15 years

Thickness measurement requirements of the previous Special Periodical Survey as contained in 7-3-2/5.15.5, except that 7-3-2/5.15.5(d)ix) is not required.

3.9.5 Tank Testing Requirements (1 July 2006)

For Vessels Age > 15 years

Tank testing requirements of the previous Special Periodical Survey as contained in 7-3-2/5.15.6 may be required as deemed necessary by the Surveyor.

3.9.6 Drydocking Requirements (1 July 2005)

For Vessels Age > 15 years

(1 July 2006) Drydocking requirements of the previous Special Periodical Survey as contained in 7-3-2/5.15.7 are to be carried out.

In lieu of the requirements above, an underwater survey in lieu of drydocking (UWILD) may be considered as equivalent.

3.11 Tankers Non ESP

In addition to the applicable requirements of 7-3-2/3.1, the Intermediate Survey is also to include the following.

3.11.1 Cargo Tanks (1 July 2006)

At each Intermediate Survey after Special Periodical Survey No. 2, at least three (3) cargo tanks of integral type: one (1) center, one (1) port wing and one (1) starboard wing tank, are to be examined internally.

3.11.2 Liquefied Gas Carriers (1 July 2003)

The Intermediate Survey is preferably to be carried out with the ship in a gas free condition. The extent of the testing required for the Intermediate Survey will normally be such that the survey cannot be carried out during a loading or discharging operation.

(1 July 2006) In addition to the applicable requirements of 7-3-2/1.13.8, the Intermediate Survey is also to include the following.

3.11.2(a) Instrumentation and safety systems

- i) The instrumentation of the cargo installation with regard to pressure, temperature and liquid level is to be visually examined and to be tested by changing the pressure, temperature and level, as applicable, and comparing with test instruments. Simulated testing may be accepted for sensors which are not accessible or for sensors located within cargo tanks or inerted hold spaces. The testing is to include testing of the alarm and safety functions.
- ii) Gas detectors are to be calibrated or verified with sample gases.
- iii) The emergency shutdown system is to be tested, without flow in the pipe lines, to verify that the system will cause the cargo pumps and compressors to stop.

3.11.2(b) Gas Burning Installations The instrumentation and safety systems for gas burning installations are to be examined and tested in accordance with the requirements of 7-3-2/3.11.2(a)i).

3.11.3 Liquefied Gas Carriers Close-up Survey Requirements (1 July 2008)

3.11.3(a) For Vessels 10 < Age ≤ 15 years

- i) All complete web frames including adjacent structural members and both transverse bulkheads complete, including girder system and adjacent members, and adjacent longitudinal bulkhead structure in a representative ballast tank.
- ii) The upper part of one web frame in another representative ballast tank.
- iii) One (1) transverse bulkhead complete, including girder system and adjacent members, and adjacent longitudinal bulkhead structure.

3.11.3(b) For Vessels Age > 15 years

All complete web frames including adjacent structural members and both transverse bulkheads complete, including girder system and adjacent members and adjacent longitudinal bulkhead structure in two (2) representative ballast tanks.

3.13 Tankers ESP (Oil Carriers and Oil Carrier Features of Combination Carriers – Non Double Hull) (1 July 2006)

In addition to the applicable requirements of 7-3-2/3.1, the Intermediate Survey is also to include the following:

3.13.1 Survey Planning (1 July 2005)

Survey planning meeting is to be held in accordance with 7-3-2/9.2.

In addition, for vessels over 10 years of age, a Survey program is to be developed in accordance with 7-3-2/9.1.

3.13.2 Piping Systems on Weather Decks (1 July 2011)

An examination as far as practical of cargo, crude oil washing, bunker, ballast, steam and vent piping systems as well as vent masts and headers. If upon examination there is any doubt as to the condition of the piping, the piping may be required to be pressure-tested, thickness-measured, or both. Venting systems of cargo tanks, including secondary means of protection, are to be examined. Randomly selected pressure/vacuum valves based upon review of maintenance records, including flame arresting and drainage arrangements, are to be opened, cleaned, examined, tested and set in accordance with manufacturer's specifications, as applicable.

3.13.3 Overall Survey Requirements (1 July 2006)

3.13.3(a) For Vessels 5 < Age ≤ 10 years (2010)

i) All ballast tanks and combined cargo/ballast tanks are to be examined.

When considered necessary by the Surveyor, thickness measurement and testing are to be carried out to ensure that the structural integrity remains effective.

ii) A ballast tank or a combined cargo/ballast tank is to be examined at subsequent annual intervals where:

- A hard protective coating has not been applied from the time of construction, or
- A soft or semi-hard coating has been applied, or
- Substantial corrosion is found within the tank, or
- The hard protective coating is found to be in less than good condition and the hard protective coating is not repaired to the satisfaction of the Surveyor.

iii) Suspect areas identified at previous surveys are to be examined.

3.13.3(b) For Vessels Age > 10 years

Overall survey requirements of the previous Special Periodical Survey as contained in 7-3-2/5.13.2 and 7-3-2/5.13.3.

3.13.4 Close-up Survey Requirements (1 July 2006)

For Vessels Age > 10 years

Close-up Survey requirements of the previous Special Periodical Survey as contained in 7-3-2/5.13.4.

3.13.5 Thickness Measurement Requirements (1 July 2006)

For Vessels Age > 10 years

Thickness measurement requirements of the previous Special Periodical Survey as contained in 7-3-2/5.13.5.

Requirements for the evaluation of the vessel's longitudinal strength, as required in 7-3-2/15.1.2, are not required unless deemed necessary by the Surveyor.

3.13.6 Tank Testing Requirements (1 July 2006)

For Vessels Age > 10 years

Tank testing requirements of the previous Special Periodical Survey as contained in 7-3-2/5.13.6 may be required as deemed necessary by the Surveyor.

3.13.7 Drydocking Requirements (1 July 2006)

3.13.7(a) For Vessels 10 < Age ≤ 15 years

Drydocking requirements of the previous Special Periodical Survey as contained in 7-3-2/5.13.7 are to be carried out.

In lieu of the above, an underwater survey in lieu of drydocking (UWILD) may be considered as equivalent.

3.13.7(b) For Vessels Age > 15 years

Drydocking requirements of the previous Special Periodical Survey as contained in 7-3-2/5.13.7 are to be carried out.

3.15 Tankers ESP (Oil Carriers and Oil Carrier Features of Combination Carriers – Double Hull) (2003)

In addition to the applicable requirements of 7-3-2/3.1, the Intermediate Survey is also to include the following:

3.15.1 Survey Planning (1 July 2005)

Survey planning meeting is to be held in accordance with 7-3-2/9.2.

In addition, for vessels over 10 years of age, a Survey program is to be developed in accordance with 7-3-2/9.1.

3.15.2 Piping Systems on Weather Decks (1 July 2011)

An examination, as far as applicable, of cargo, crude oil washing, bunker, ballast, steam and vent piping systems as well as vent masts and headers. If upon examination there is any doubt as to the condition of the piping, the piping may be required to be pressure-tested, thickness-measured, or both. Venting systems of cargo tanks, including secondary means of protection, are to be examined. Randomly selected pressure/vacuum valves based upon review of maintenance records, including flame arresting and drainage arrangements, are to be opened, cleaned, examined, tested and set in accordance with manufacturer's specifications, as applicable.

3.15.3 Overall Survey Requirements (1 July 2006)

3.15.3(a) For Vessels 5 < Age ≤ 10 years (2010)

i) (1 July 2016) Ballast Tanks. In addition to 7-3-2/3.1.2, representative ballast tanks selected by the Surveyor including fore and aft peak tanks and a number of other tanks, taking into account the total number and types of ballast tanks, are to be examined. If such overall survey reveals no visible structural defects, the examination may be limited to verification that the corrosion prevention system remains effective.

ii) A ballast tank or a combined cargo/ballast tank is to be examined at subsequent annual intervals where:

- A hard protective coating has not been applied from the time of construction, or
- A soft or semi-hard coating has been applied, or
- Substantial corrosion is found within the tank, or
- The hard protective coating is found to be in less than good condition and the hard protective coating is not repaired to the satisfaction of the surveyor.

iii) Suspect areas identified at previous surveys are to be examined.

3.15.3(b) For Vessels Age > 10 years

Overall Survey requirements of the previous Special Periodical Survey as contained in 7-3-2/5.14.2 and 7-3-2/5.14.3.

3.15.4 Close-up Survey Requirements (1 July 2006)

For Vessels Age > 10 years

Close-up Survey requirements of the previous Special Periodical Survey as contained in 7-3-2/5.14.4.

3.15.5 Thickness Measurement Requirements (1 July 2013)

For vessels built under IACS Common Structural Rules, the identified substantial corrosion areas are required to be examined and additional thickness measurements are to be carried out.

For Vessels Age > 10 years

Thickness measurement requirements of the previous Special Periodical Survey as contained in 7-3-2/5.14.5.

Requirements for the evaluation of the vessel's longitudinal strength, as required in 7-3-2/15.1.2, are not required unless deemed necessary by the Surveyor.

3.15.6 Tank Testing Requirements (1 July 2006)

For Vessels Age > 10 years

Tank testing requirements of the previous Special Periodical Survey as contained in 7-3-2/5.14.6 may be required as deemed necessary by the Surveyor.

3.15.7 Drydocking Requirements (1 July 2006)

3.15.7(a) For Vessels 10 < Age ≤ 15 years

Drydocking requirements of the previous Special Periodical Survey as contained in 7-3-2/5.14.7 are to be carried out.

In lieu of the above, an underwater survey in lieu of drydocking (UWILD) may be considered as equivalent.

3.15.7(b) For Vessels Age > 15 years

Drydocking requirements of the previous Special Periodical Survey as contained in 7-3-2/5.14.7 are to be carried out.

3.17 Bulk Carriers – Double Skin ESP and Bulk Carrier Features of Combination Carriers – Double Skin ESP (2005)

In addition to the applicable requirements of 7-3-2/3.1, the Intermediate Survey is also to include the following:

3.17.1 Survey Planning (1 July 2005)

Survey planning meeting is to be held in accordance with 7-3-2/9.2.

In addition, for vessels over 10 years of age, a Survey program is to be developed in accordance with 7-3-2/9.1.

3.17.2 Overall Survey Requirements (1 July 2006)

3.17.2(a) For Vessels 5 < Age ≤ 10 years

i) *Ballast tanks.* In addition to 7-3-2/3.1.2, representative ballast tanks selected by the Surveyor including fore and aft peak tanks and a number of other tanks, taking into account the total number and types of ballast tanks, are to be examined.

If such overall survey reveals no visible structural defects, the examination may be limited to verification that the corrosion prevention system remains effective.

ii) *Cargo holds.* Overall survey of all cargo holds are to be carried out.

iii) Suspect areas identified at previous surveys are to be examined.

3.17.2(b) For Vessels Age > 10 years

Overall survey requirements of the previous Special Periodical Survey as contained in 7-3-2/5.19.2 and 7-3-2/5.19.3.

Internal examination of fuel oil, lube oil and fresh water tanks in the cargo length is not required unless deemed necessary by the Surveyor.

3.17.3 Close-up Survey Requirements (1 July 2006)

For close-up surveys of wing ballast tanks of ore carriers, the survey requirements of wing ballast tanks for oil tankers as given in 7-3-2/3.13.4 apply.

3.17.3(a) For Vessels 5 < Age ≤ 10 years

- i) Where considered necessary by the Surveyor as a result of the overall survey, the survey is to be extended to include a close-up survey of those areas of structure in the cargo holds selected by the Surveyor.
- ii) Close-up survey of suspect areas identified at previous surveys.

3.17.3(b) For Vessels Age > 10 years

Close-up survey requirements of the previous Special Periodical Survey as contained in 7-3-2/5.19.4.

3.17.4 Thickness Measurement Requirements (1 July 2006)

3.17.4(a) For Vessels 5 < Age < 10 years

- i) Thickness measurements are to be carried out to an extent sufficient to determine both general and local corrosion levels at areas subject to close-up survey, and areas of substantial corrosion identified at previous surveys.
- ii) Where substantial corrosion is found, additional thickness measurements, in accordance with 7-3-2/7, are to be taken to confirm the extent of substantial corrosion. These extended thickness measurements are to be carried out before the survey is credited as completed.
- iii) The extent of thickness measurements may be specially considered provided the Surveyor is satisfied by the close-up survey that there is no structural diminution and the hard protective coating is found in GOOD condition.

(1 July 2013) For vessels built under IACS Common Structural Rules, the identified substantial corrosion areas may be:

- a) Protected by coating applied in accordance with the coating manufacturer's requirements and examined at annual intervals to confirm the coating in way is still in GOOD condition, or alternatively
- b) Required to be measured at annual intervals.

3.17.4(b) For Vessels Age > 10 years

Thickness measurements requirements of the previous Special Periodical Survey as contained in 7-3-2/5.19.5.

3.17.5 Tank Testing Requirements (1 July 2006)

For Vessels Age > 10 years

Tank testing requirements of the previous Special Periodical Survey as contained in 7-3-2/5.19.6 may be required as deemed necessary by the Surveyor.

3.17.6 Drydocking Requirements (1 July 2006)

3.17.6(a) For Vessels 10 < Age ≤ 15 years

Drydocking requirements of the previous Special Periodical Survey as contained in 7-3-2/5.19.7 are to be carried out.

In lieu of the above, an underwater survey in lieu of drydocking (UWILD) may be considered as equivalent.

3.17.6(b) For Vessels Age > 15 years

Drydocking requirements of the previous Special Periodical Survey as contained in 7-3-2/5.19.7 are to be carried out.

3.19 Chemical Carriers ESP (1 July 2006)

In addition to the applicable requirements of 7-3-2/3.1, the Intermediate Survey is also to include the following:

3.19.1 Survey Planning

Survey planning meeting is to be held in accordance with 7-3-2/9.2.

In addition, for vessels over 10 years of age, a Survey program is to be developed in accordance with 7-3-2/9.1.

3.19.2 Piping Systems on Weather Decks (1 July 2011)

An examination as far as practical of cargo, bunker, ballast, steam and vent piping systems as well as vent masts and headers. If upon examination there is any doubt as to the condition of the piping, the piping may be required to be pressure-tested, thickness-measured, or both. Venting systems of cargo tanks, including secondary means of protection, are to be examined. Randomly selected pressure/vacuum valves based upon review of maintenance records, including flame arresting and drainage arrangements, are to be opened, cleaned, examined, tested and set in accordance with manufacturer's specifications, as applicable.

3.19.3 Overall Survey Requirements

3.19.3(a) For Vessels 5 < Age ≤ 10 years (2010)

- i) All ballast tanks and combined cargo/ballast tanks, including double bottom tanks, are to be examined, and this examination is to be supplemented by thickness measurement and testing, as deemed necessary to ensure that the structural integrity remains effective.
- ii) A ballast tank is to be examined at subsequent annual intervals where:
 - A hard protective coating has not been applied from the time of construction, or
 - A soft or semi-hard coating has been applied, or
 - Substantial corrosion is found within the tank, or
 - The hard protective coating is found to be in less than good condition and the hard protective coating is not repaired to the satisfaction of the surveyor.
- iii) Suspect areas identified at previous surveys are to be examined.

3.19.3(b) For Vessels Age > 10 years

Overall survey requirements of the previous Special Periodical Survey as contained in 7-3-2/5.21.2 and 7-3-2/5.21.3.

3.19.4 Close-up Survey Requirements

For Vessels Age > 10 years

Close-up survey requirements of the previous Special Periodical Survey as contained in 7-3-2/5.21.4.

3.19.5 Thickness Measurement Requirements

For Vessels Age > 10 years

Thickness measurement requirements of the previous Special Periodical Survey as contained in 7-3-2/5.21.5.

3.19.6 Tank Testing Requirements

For Vessels Age > 10 years

Tank testing requirements of the previous Special Periodical Survey as contained in 7-3-2/5.21.6 may be required as deemed necessary by the Surveyor.

3.19.7 Cargo and Ballast Piping

For Vessels Age > 10 years

Examination and testing requirements of the previous Special Periodical Survey as contained in 7-3-2/5.21.7.

3.19.8 Drydocking Requirements

3.19.8(a) For Vessels 10 < Age ≤ 15 years

Drydocking requirements of the previous Special Periodical Survey as contained in 7-3-2/5.21.8 are to be carried out.

In lieu of the above, an underwater survey in lieu of drydocking (UWILD) may be considered as equivalent.

3.19.8(b) For Vessels Age > 15 years

Drydocking requirements of the previous Special Periodical Survey as contained in 7-3-2/5.21.8 are to be carried out.

5 Special Periodical Surveys

5.1 All Vessels

(1 July 2006) In addition to the requirements of the Annual Survey – Hull, the Special Periodical Survey – Hull is to include sufficient examination, tests and checks carried out by the Surveyors to satisfy themselves that the hull, equipment and related piping are in or are placed in satisfactory condition and are fit for the intended purpose for the new period of class of five (5) years to be assigned, subject to proper maintenance and operation and to periodic surveys being carried out at the due dates. Special Periodical Survey is to include the following:

5.1.1 Survey Planning Meeting *(1 July 2006)*

A survey planning meeting is to be held prior to the commencement of the survey.

5.1.2 Drydocking Survey

The vessel is to be placed in a drydock or upon a slipway and all items of Section 7-4-1 are to be examined.

5.1.3 Rudder

The rudder is to be examined and, when required, lifted and the gudgeons rebushed. The condition of carrier and steadiment/rudder stock bearings and the effectiveness of stuffing boxes are to be ascertained when the rudder is lifted.

5.1.4 Anchor and Chain Cable

The anchors and chain cables are to be ranged, examined and the required complement and condition confirmed. The chain locker, holdfasts, hawse pipes and chain stoppers are to be examined and pumping arrangements of the chain locker operationally tested.

At Special Periodical Survey No. 2 and subsequent Special Periodical Surveys, chain cables are to be gauged and renewed in cases where their mean diameter is 12% or more below the original required nominal size. Where structural alterations to the vessel have resulted in a higher equipment numeral, the original chain cables may be used until their mean diameter has been reduced to 12% below the nominal diameter of the larger cable required by the higher equipment numeral.

5.1.5 Shell Openings and Their Closures

All openings in the shell including overboard discharges and ash chutes are to be examined.

5.1.6 Decks, Bulkheads and Shell Plating

All decks, watertight bulkheads, and internal and external surfaces of shell plating are to be examined. Plating in way of sideshell or superstructure portlights is to be especially examined.

5.1.7 Overall Survey Requirements

5.1.7(a) Spaces. An Overall Survey of all spaces including holds and their tween decks, where fitted; double bottom, deep, ballast, peak and cargo tanks; pumprooms, pipe tunnels, duct keels, machinery spaces, dry spaces, cofferdams and voids, including the plating and framing, bilges and drain wells, sounding, venting, pumping and drainage arrangements.

(1 July 2006) Internal examination of fuel oil, lube oil and fresh water tanks is to be carried out in accordance with 7-3-2/5.1.7(e).

Where sounding pipes are fitted, the Surveyor is to confirm that a thick steel plate is securely fixed below the sounding pipe for the rod to strike upon.

Electrical bonding arrangements, including bonding straps where fitted, for the piping systems located within cargo tanks, pipe tunnels, cofferdams and void spaces bounding cargo tanks are also to be examined.

(1 July 2006) This examination is to be supplemented by thickness measurement and testing as required to ensure that the structural integrity remains effective. The aim of the examination is to discover substantial corrosion, significant deformation, fractures, damages or other structural deterioration, that may be present.

5.1.7(b) Engine Room Spaces (2003). Engine room structure is to be examined. Particular attention is to be given to tank tops, shell plating in way of tank tops, brackets connecting side shell frames and tank tops, and engine room bulkheads in way of tank top and bilge wells. Particular attention is to be given to the sea suction, seawater cooling pipes and overboard discharge valves and their connection to the side shell plating. Where extensive areas of wastage are found, thickness measurements are to be carried out, and renewals and/or repairs made where wastage exceeds allowable margins.

5.1.7(c) Ballast Tanks and Combined Cargo/Ballast Tanks (2010). Where provided, the condition of corrosion prevention system of ballast tanks and combined cargo/ballast tanks is to be examined.

Ballast tanks and combined cargo/ballast tanks other than double bottom tanks, where a hard protective coating is found in POOR condition and Owners or their representatives elect not to restore the coating, where soft or semi-hard coating has been applied or where a hard protective coating has not been applied from time of construction, the tanks in question are to be internally examined at each subsequent Annual Survey. Thickness measurements are to be carried out as deemed necessary by the Surveyor.

When such breakdown of hard protective coating is found in double bottom ballast tanks and owners or their representatives elect not to restore the coating, where a soft or semi-hard coating has been applied, or where a hard protective coating has not been applied from time of construction, the tanks in question are to be internally examined at each subsequent Annual Survey where substantial corrosion is documented. Thickness measurements are to be carried out as required.

5.1.7(d) Permanent Ballast Tanks (2004). Internal examination requirements will be specially considered for tanks used exclusively for permanent ballast which are fitted with an effective means of corrosion control.

5.1.7(e) Fuel Oil Tanks, Lube Oil Tanks, and Freshwater Tanks (1 July 2006). Where tanks of integral structural type, except for peak tanks, are used primarily for heavy fuel oil or exclusively for light oils or fresh water, the internal examination may be specially considered, provided a general external examination and the following internal examinations are carried out.

Minimum requirements for internal examination of fuel oil, lube oil and fresh water tanks at Special Periodical Surveys are as follows.

i) *Special Periodical Survey No. 1 (Age ≤ 5 Years)*

None

ii) *Special Periodical Survey No. 2 (5 < Age ≤ 10 Years)*

- (2008) One (1) fuel oil tank in the Cargo length area. For vessels without a defined cargo area a minimum of one (1) fuel oil tank.
- One (1) freshwater tank

- iii) *Special Periodical Survey No. 3 (10 < Age ≤ 15 Years)*
- (2008) One (1) fuel oil tank in way of the engine room
 - (2008) Two (2) fuel oil tanks in the Cargo length area. For vessels without a defined cargo area a minimum of two (2) fuel oil tanks. One (1) deep tank is to be included, if fitted
 - All freshwater tanks
- iv) *Special Periodical Survey No. 4 and Subsequent Special Periodical Surveys (Age > 15 Years)*
- (2008) One (1) fuel oil tank in way of the engine room
 - (2008) Half of all fuel oil tanks in the Cargo length area, minimum two (2). For vessels without a defined cargo area, half of all fuel oil tanks, a minimum of two (2). One (1) deep tank is to be included, if fitted
 - One (1) lube oil tank
 - All freshwater tanks

Note: If a selection of tanks is accepted for examination, then different tanks are to be examined at each Special Periodical Survey on a rotational basis.

Independent oil tanks in machinery spaces are to be externally examined and, if deemed necessary, tested under a head of liquid.

5.1.8 Protection of Other Openings (2003)

5.1.8(a) Tank Protective Devices

- i) All tank protective devices, where fitted, are to be examined externally for proper assembly and installation, damage, deterioration or traces of carryover at the outlets.
- ii) All pressure-vacuum valves and pressure relief valves are to be opened out, pressure and vacuum valve discs checked for good contact with their respective seats and/or proved by testing.

5.1.8(b) *Airpipes (1 July 2006)*. All airpipes are to be opened out and closing arrangements and flame screens, if fitted, are to be examined both externally and internally. For designs where the inner parts cannot be properly examined from outside, this is to include removal of the head from the air pipe. Particular attention is to be paid to the condition of the zinc coating in heads constructed from galvanized steel.

5.1.8(c) *Watertight Bulkheads (2007)*. In addition to the examination required by 7-3-2/1.1.2(e), watertight doors are to be operationally tested and effectiveness to maintain tightness is to be confirmed.

5.1.9 Thickness Measurement Requirements

Minimum requirements for thickness measurement at Special Periodical Surveys are as follows:

- Vessels under 90 meters (295 feet) in length, see 7-3-2/5.1.15a).
- Passenger Vessels and High Speed Craft under 61 meters (200 feet) in length, see 7-3-2/5.1.15(a).
- Passenger Vessels and High Speed Craft 61 meters (200 feet) and over in length, see 7-3-2/5.1.15(c).
- Non ESP Tankers, Gas and Independent Tank Carriers 90 meters (295 feet) and over in length, see 7-3-2/5.1.15(b).
- Non ESP/ESDC Vessels 90 meters (295 feet) and over in length, see 7-3-2/5.1.15(c).
- Barges, see 7-3-2/5.5.1(f).
- Bulk Carriers – Non Double Skin ESP and Bulk Carrier features of Combination Carriers – Non Double Skin ESP, see 7-3-2/5.7.5.
- Bulk Carriers –Double Skin ESP and Bulk Carrier features of Combination Carriers –Double Skin ESP, see 7-3-2/5.19.5.

- Tankers ESP (Oil Carriers and Oil Carrier Features of Combination Carriers – Non Double Hull), see 7-3-2/5.13.4.
- Tankers ESP (Oil Carriers and Oil Carrier Features of Combination Carriers – Double Hull), see 7-3-2/5.14.5.
- (2004) General Dry Cargo Vessels (ESDC), see 7-3-2/5.15.5.
- (1 July 2006) Chemical Carriers ESP, see 7-3-2/5.21.4.

Thickness measurements taken during or after the fourth Annual Survey will be credited towards the Special Periodical Survey.

(1 July 2006) The Surveyor may require further thickness measurements, as deemed necessary. Renewals are to be made when wastage exceeds allowable margins.

Where substantial corrosion is found, additional thickness measurements, in accordance with 7-3-2/7, are to be taken to confirm the extent of substantial corrosion.

(2004) These extended thickness measurements are to be carried out before the survey is credited as completed.

Where reduced scantlings on the basis of effective corrosion control have been adopted, the results of any gaugings are to be evaluated based on the scantlings before reduction.

Transverse sections are to be chosen based upon cargo/ballast history, arrangement and condition of coatings. Thickness measurement locations are to be chosen from areas likely to be most exposed to corrosion effects, (i.e., typically in way of ballast tanks) or are revealed from deck plating thickness measurements.

(1 July 2006) For Non-ESP/ESDC vessels, thickness measurement requirements in way of internals may be specially considered by the Surveyor if the corrosion prevention system remains in GOOD condition.

5.1.10 Tank Testing (2004)

Boundaries of double bottom, deep, ballast, peak and other tanks, including holds adapted for the carriage of salt water ballast, are to be tested with a head of liquid to the top of air pipes or to near the top of hatches for ballast/cargo holds, except that cargo tanks on chemical carriers and oil carriers of both single and double hull construction may be tested to the highest point that liquid will rise under service condition. Boundaries of fuel oil, lube oil and fresh water tanks may be tested with a head of liquid to the highest point that liquid will rise under service condition. Tank testing of fuel oil, lube oil and fresh water tanks may be specially considered based on a satisfactory external examination of the tank boundaries, and a confirmation from the Master stating that the pressure testing has been carried out according to the requirements with satisfactory results, provided that representative tanks for fuel oil, lube oil and fresh water are tested.

The testing of double bottoms and other spaces not designed for the carriage of liquid may be omitted, provided a satisfactory internal examination together with an examination of the tanktop is carried out.

The Surveyor may require further tank testing, as deemed necessary.

5.1.11 Hatch Covers and Coamings

(1 July 2006) A thorough examination of the items listed in 7-3-2/1.1, including close-up survey of hatch cover plating and hatch coaming plating, is to be carried out.

(2005) Checking of the satisfactory operation of all mechanically operated hatch covers is to be made, including:

- Stowage and securing in open condition
- Proper fit and efficiency of sealing in closed condition
- Operational testing of hydraulic and power components, wires, chains, and link drives

Checking the effectiveness of sealing arrangements of all hatch covers is to be made by hose testing or equivalent. Where the omission of gaskets has been approved in accordance with SVR 3-2-15/11.1, hose tests are not required, provided the surveys required by 7-3-2/1.1.1(f) are satisfactorily carried out.

(1999) Where extensive areas of wastage of steel hatch covers, coamings or their stiffeners are found, thickness measurements are to be carried out and renewals made when wastage exceeds allowable margins. Where substantial corrosion is found, additional thickness measurements in accordance with 7-3-2/7 are to be taken to confirm the extent of substantial corrosion.

(1 July 2008) For Container Vessels with hatch coaming top and/or side plating consisting of higher-strength steel plate over 50 mm (2.0 in.) in thickness, the following is to be carried out within $0.3L \sim 0.7L$ at every Special Survey after Special Survey No. 2:

- Visual Inspection of all hatch coaming top and side plate butt weld joints.

In addition, vessels constructed with EH40 material and greater with thickness of 60 mm ($2\frac{3}{8}$ in.) and above are to be subject to:

- Ultrasonic test of all hatch coaming top and side plate butt weld block erection joints.

5.1.12 Independent Cargo Tanks

The following requirements apply only to independent cargo tanks (i.e., separated from the main hull structure), except those on Liquefied Gas Carriers (see 7-3-2/5.11).

5.1.12(a) Internal Examination. An internal examination is to be made of all independent cargo tanks including internal mountings and equipment. The tanks are to be thoroughly cleaned and cleared of gas before entry, and every precaution is to be taken to insure safety during examination.

5.1.12(b) Independent Cargo Tank Supports and Hull Structure Fittings. Foundations, chocks, sway braces, keys and anti-flotation arrangements are to be examined.

5.1.12(c) Venting systems for the cargo containment systems are to be examined. All relief valves are to be opened, examined, tested and readjusted, as necessary. Liquid-level indicators are to be proven in order. Where a proper record of continuous overhaul and retesting of individually identifiable relief valves is maintained, consideration will be given to acceptance on the basis of opening, internal examination and testing of a representative sampling of valves including each size of each type of relief valve in use, provided there is logbook evidence that the remaining valves have been overhauled and tested since the crediting of the previous Special Periodical Survey. The testing and setting of relief valves may be carried out in place or after removal.

5.1.12(d) All piping, machinery, and equipment for loading, venting, compressing, refrigerating, liquefying, heating or otherwise handling the cargo are to be generally examined. All quick-closing and emergency shut-off valves in the cargo piping systems are to be examined and tested.

5.1.12(e) Insulation Removals. Insulation is to be removed in way of any distorted or otherwise suspect part in the cargo containment system and elsewhere, as required by the Surveyor. Insulation may be required to be removed to carry out any of the previous items at the discretion of the Surveyor.

5.1.12(f) Thickness Gauging. Where there is evidence of corrosion, the plating or structure of the independent tank is to be gauged by nondestructive means to determine the thickness.

5.1.12(g) Tightness Tests. Tanks, other than independent pressure tanks, are to be tested with a head of liquid to the overflow or by an alternative method meeting the approval of the attending Surveyor. In certain designs, water should not be used as the test liquid as it may overstress or contaminate the tank.

5.1.12(h) Independent Pressurized Cargo Tanks (2011). Independent pressure tanks, complying with the requirements of SVR Section 4-4-1, are to be hydrostatically, hydropneumatically or otherwise pressure tested at each Special Periodical Survey. This requirement may be modified at alternate Special Periodical Surveys if the internal and external survey of such pressure vessels indicates no evidence of leakage, distortion or wastage. The test pressure is to be 1.25 times the maximum allowable relief valve setting (MARVS) which corresponds to the maximum allowable working pressure of the independent tank. Independent pressurized bulk cement/barite tanks with

a maximum allowable operating pressure of less than 6.9 bar (7 kgf/cm², 100 psi) are to be examined externally at each Special Periodical Survey, including foundations and mountings. Provided the external examination is satisfactory no internal examination will be necessary. All relief valves are to be opened, examined, and tested. Vent piping for the relief valves and all other piping for the bulk cement/barite system are to be generally examined.

5.1.12(i) Special Periodical Survey – Hull No. 3. At Special Periodical Survey – Hull No. 3, the plating of all independent cargo tanks (shell, heads, and domes) is to be gauged by nondestructive means to determine the thickness. At subsequent Special Periodical Surveys, special consideration will be given to modifying this requirement upon prior application from the owners.

5.1.13 Vessels Constructed of Aluminum Alloys

In addition to the applicable requirements of 7-3-2/5.1, particular attention is to be given to insulation material in joints of shell connections between dissimilar metals, which is to be found or made effective, as necessary.

5.1.14 Vessels Constructed of Reinforced Plastic

In addition to the applicable requirements of 7-3-2/5.1, the Special Periodical Survey is to include the following:

5.1.14(a) The framing and holds, hull laminate of the tween deck, deep tanks, peaks, bilges and drain wells, and machinery spaces are to be cleaned and examined. Linings, ceiling, tanks and portable ballast are to be removed as considered necessary by the attending Surveyor.

5.1.14(b) Where there is evidence of cracking, distortion, wetness or delamination, destructive or nondestructive testing and removal and repair of the defect is subject to the discretion of the attending Surveyor.

5.1.14(c) The hull, fastenings and backing reinforcements in way of hull fittings and attachments are to be examined. Fastenings are to be withdrawn as considered necessary by the attending Surveyor.

5.1.14(d) The efficiency of hand pumps or other drainage arrangements for end spaces is to be tested.

5.1.14(e) (2016) Additionally for Sailing and Unpowered Vessels, where applicable, ballast-keel fastenings and all openings to the sea, including sanitary and other overboard discharges, together with the cocks and valves connected therewith, are to be examined while the vessel is in drydock. Mast foundation and connection to the hull are to be examined.

5.1.15 Minimum Requirements for Thickness Measurements at Special Periodical Surveys for Vessels without ESP and ESDC Notations

5.1.15(a) Vessels Under 90 meters (295 feet) in Length; Passenger Vessels and High Speed Craft under 61 meters (200 feet) in Length

i) Special Periodical Survey No. 1 (Age ≤ 5 Years) (2003)

- Suspect areas throughout the vessel.

ii) Special Periodical Survey No. 2 (5 < Age ≤ 10 Years) (2003)

- Suspect areas throughout the vessel.
- One (1) transverse section of deck plating within the midship 0.5L (in way of cargo space, if applicable).

iii) Special Periodical Survey No. 3 (10 < Age ≤ 15 Years) (1 July 2006)

- Suspect areas throughout the vessel.
- Two (2) transverse sections within the amidships 0.5L (in way of two (2) different cargo (or ballast) spaces, if applicable).
- Internals in forepeak and afterpeak tanks.
- All cargo hold hatch covers and coamings (stiffeners and plating).

- iv) *Special Periodical Survey No. 4 and Subsequent Special Periodical Surveys (Age > 15 Years) (2003)*
- Suspect areas throughout the vessel.
 - Three (3) transverse sections within the amidships 0.5L, (in way of cargo spaces, if applicable), avoiding those spaces previously gauged.
 - Internals in forepeak and after peak tanks.
 - All cargo hold hatch covers and coamings (stiffeners and plating).
 - Lowest strake and strakes in way of tween decks of all transverse bulkheads in cargo spaces together with internals in way.
 - Wind-and-water strakes, port and starboard, full length.
 - All exposed main deck and superstructure deck plating.
 - Flat keel plating full length. Also, additional bottom plates in way of cofferdams, machinery spaces and aft ends of tanks.
 - For tank vessels, gauging of principal internals throughout cargo and ballast tanks.
 - For High Speed Craft, one (1) additional transverse section forward of 0.125L.
 - Plating of seachests. Shell plating in way of overboard discharges as considered necessary by the attending Surveyor.

5.1.15(b) *Non ESP Tankers, Gas and Independent Tank Carriers 90 meters (295 feet) and over in Length (2006)*. These requirements do not apply to independent cargo tanks.

- i) *Special Periodical Survey No. 1 (Age ≤ 5 Years)*
- Suspect areas throughout the vessel.
 - (1 July 2008) Additionally for Liquefied Gas Carriers, one section of deck plating for the full beam of the ship within 0.5L amidships in way of a ballast tank, if any.
- ii) *Special Periodical Survey No. 2 (5 < Age ≤ 10 Years)*
- All main deck plates within the amidships 0.5L or cargo tank section, whichever is longer.
 - One (1) transverse section within the amidships 0.5L.
 - Plates in wind-and-water strakes outside the amidships 0.5L.
 - All complete transverse web frame rings in a ballast wing tank or ballast double hull tank, if any.
 - One (1) deck transverse in each of the remaining ballast tanks, if any.
 - Both transverse bulkheads including girder system in a ballast wing tank or ballast double hull tank, if any, or a cargo wing tank used primarily for water ballast.
 - Lower part of transverse bulkhead including girder system in each remaining ballast tank, one (1) cargo wing tank and two (2) cargo center tanks.
 - Internals in forepeak and afterpeak tanks.
 - Suspect areas throughout the vessel.
- iii) *Special Periodical Survey No. 3 (10 < Age ≤ 15 Years)*
- All main deck plates within the amidships 0.5L or cargo tank, whichever is longer.
 - Two (2) transverse sections within the amidships 0.5L.
 - Plates in wind-and-water strakes outside the amidships 0.5L.

- (1 July 2008) Additionally for Liquefied Gas Carriers, all wind and water strakes within the cargo area.
 - All complete transverse web frame rings in all ballast tanks and in a cargo wing tank.
 - A minimum of 30% of all complete transverse web frame rings in each remaining cargo wing tank. (In calculating the 30% minimum, the number of web frame rings is to be rounded up to the next whole integer.)
 - A minimum of 30% of deck and bottom transverse in each cargo center tank. (In calculating the 30% minimum, the number of transverses is to be rounded up to the next whole integer.)
 - All transverse bulkheads including girder and stiffener systems in all cargo and ballast tanks.
 - Additional complete transverse web frame rings as considered necessary by the Surveyor.
 - Internals in forepeak and afterpeak tanks including plating and stiffeners of forepeak and afterpeak tank bulkheads.
 - Suspect areas throughout the vessel.
- iv) *Special Periodical Survey No. 4 and Subsequent Special Periodical Surveys (Age > 15 Years)*
- All exposed main deck plates, full length. Also, exposed first-tier superstructure deck plates (poop bridge and forecastle decks).
 - All keel plates full length. Also, additional bottom plates in way of cofferdams, machinery space and aft ends of tanks.
 - (1 July 2008) Additionally for Liquefied Gas Carriers, duct keel plating and internals, and each bottom plate within the cargo area.
 - A minimum of three (3) transverse sections within the amidships 0.5L.
 - All complete transverse web frame rings in all ballast tanks and in a cargo wing tank.
 - A minimum of 30% of all complete transverse web frame rings in each remaining cargo wing tank. (In calculating the 30% minimum, the number of web frame rings is to be rounded up to the next whole integer.)
 - A minimum of 30% of deck and bottom transverse in each cargo center tank. (In calculating the 30% minimum, the number of transverses is to be rounded up to the next whole integer.)
 - All transverse bulkheads including girder and stiffener systems in all cargo and ballast tanks.
 - Additional complete transverse web frame rings as considered necessary by the Surveyor.
 - Any additional tanks and structure as considered necessary by the Surveyor.
 - Internals in forepeak and afterpeak tanks including plating and stiffeners of forepeak and afterpeak tank bulkheads.
 - All plates in two (2) wind-and-water strakes, port and starboard full length.
 - Suspect areas throughout the vessel.
 - Plating of seachests. Shell plating in way of overboard discharges as considered necessary by the attending Surveyor.

5.1.15(c) *Vessels 90 meters (295 feet) and over in Length; Passenger Vessels and High Speed Craft 61 meters (200 feet) and over in Length*

i) *Special Periodical Survey No. 1 (Age ≤ 5 Years)*

- Suspect areas throughout the vessel.

ii) *Special Periodical Survey No. 2 (5 < Age ≤ 10 Years)*

- Suspect areas throughout the vessel.
- One (1) transverse section of deck plating within the amidships 0.5L (in way of a cargo space, if applicable).

iii) *Special Periodical Survey No. 3 (10 < Age ≤ 15 Years)*

- Suspect areas throughout the vessel.
- Two (2) transverse sections within the amidships 0.5L (in way of two (2) different cargo spaces, if applicable).
- (1999) Internals in forepeak and afterpeak tanks including plating and stiffeners of forepeak and afterpeak tank bulkheads.
- All cargo hold hatch covers and coamings (plating and stiffeners).

iv) *Special Periodical Survey No. 4 and Subsequent Special Periodical Surveys (Age > 15 Years)*

- Suspect areas throughout the vessel.
- A minimum of three (3) transverse sections within the amidships 0.5L (in way of cargo spaces, if applicable).
- Internals in forepeak and afterpeak tanks including plating and stiffeners of forepeak and afterpeak tank bulkheads.
- (1999) All cargo hold hatch covers and coamings (plating and stiffeners).
- Lowest strakes and strakes in way of tween decks of all transverse bulkheads in cargo space together with internals in way.
- All plates in two (2) wind-and-water strakes, port and starboard, full length.
- All exposed main deck plates full length and all exposed first-tier superstructure deck plates (poop, bridge and forecastle decks).
- All keel plates full length. Also, additional bottom plates in way of cofferdams, machinery space and aft ends of tanks.
- Duct keel or pipe tunnel plating and internals.
- (2003) Plating of seachests. Shell plating in way of overboard discharges as considered necessary by the attending Surveyor.

5.1.16 *Vessels in Lightering Service (1 July 2004)*

In addition to the applicable requirements of 7-3-2/5.1, the Special Periodical Survey is also to include an external examination and internal Close-up Survey of hull structures, including thickness measurements, where fenders for lightering operation were located.

5.1.17 *Bilge and Ballast Piping (1 July 2006)*

All bilge and ballast piping systems are to be examined and operationally tested to working pressure to the satisfaction of the Surveyor to ensure that tightness and condition remain satisfactory.

5.3 Accommodation Barges

In addition to the applicable requirements of 7-3-2/5.1, the Special Periodical Survey is to include the following:

5.3.1 Special Periodical Survey No. 1

Special Periodical Survey No. 1 is to include compliance with all Annual Survey requirements and in addition, the following requirements are to be carried out as applicable, the parts examined and placed in satisfactory condition:

5.3.1(a) General – All Types

- i) Where double-bottom and other tanks are used primarily for heavy oil or exclusively for light oils, the gas freeing and internal cleaning and examination may be waived, provided that, upon a general external examination of the tanks, the Surveyor finds their condition satisfactory.
- ii) Attachment of anchor racks and anchor cable fairleads are to be examined.
- iii) Structures such as deck houses, superstructures, helicopter landing pads and their respective attachment to the deck or hull.
- iv) Parts of the unit which are underwater and inaccessible to the Surveyor may be accepted on the basis of an examination by a qualified diver carried out in the presence of the Surveyor. Video or photo records, nondestructive testing and thickness gauging may be required in addition to the diver's report.
- v) At each Special Periodical Survey, thickness measurements are to be carried out where wastage is evident or suspect. At Special Periodical Survey No. 2 and subsequent Special Periodical Surveys, representative thickness measurements will be required. These will be specified in advance. Special attention is to be paid to splash zones on hulls, legs or related structure, and in ballast tanks, pre-load tanks, free-flooding spaces, spud cans and mats.
- vi) Where inspection of underwater joints is required, sufficient cleaning is to be carried out in way and water clarity to be adequate to permit meaningful visual, video, camera or NDT examination, as required. Every effort is to be made to avoid damage to special coatings when cleaning.
- vii) All openings to the sea, including sanitary and other overboard discharge together with the cocks and valves connected therewith are to be examined internally and externally at the time of underwater examination in lieu of drydocking, and the fastenings to the shell plating are to be renewed when considered necessary by the Surveyor.

5.3.2 Special Periodical Survey No. 2 and Subsequent Special Periodical Surveys

These surveys are to be at least as comprehensive as Special Periodical Survey No. 1, with special attention being given to the conditions and thickness of material in high corrosion areas. The subsequent Special Periodical Surveys of ship or barge type units will include the requirements of the following Barge Special Periodical Survey requirements.

5.5 Barges

In addition to the applicable requirements of 7-3-2/5.1, the Special Periodical Survey is to include the following:

5.5.1 Special Periodical Survey No. 1 and Subsequent Special Periodical Surveys

5.5.1(a) *Drydocking Survey (1995)*. In lieu of the requirements of 7-3-2/5.1.2, an Underwater Inspection in Lieu of Drydocking (UWILD) may be carried out for alternate Drydocking Survey as allowed by 7-2-1/11.5, except that Oil Tank barges, Fuel Oil Tank Barges and Chemical Tank Barges 122 meters (400 feet) and over in length are to be placed in drydock or upon a slipway, and all applicable items of Section 7-4-1 are to be examined. In addition, all openings to the sea, including sanitary and other overboard discharges, together with their valves, are to be examined internally and externally. The fastenings to the shell are to be renewed when considered necessary by the Surveyor.

5.5.1(b) *Pumps and Piping Arrangement (1995)*. Pumps and piping arrangements, including valves, cocks, pipes and strainers, are to be examined. The Surveyor is to be satisfied with the operation of the bilge system, where fitted. Other systems are to be tested as considered necessary.

5.5.1(c) *Heat Exchangers and Unfired Pressure Vessels (1995)*. Heat exchangers and other unfired pressure vessels with design pressures over 6.9 bar (7 kgf/cm², 100 psi) are to be examined, opened or thickness gauged and pressure tested as considered necessary, and associated relief valves proven operative. Evaporators that operate with a vacuum on the shell need not be opened, but may be accepted on the basis of satisfactory external examination and operational test or review of operating records.

5.5.1(d) *Fire Extinguishing Apparatus (1 July 2005)*. An examination of the fire extinguishing apparatus required for classification as outlined in *Rules for Building and Classing Steel Barges*, Part 3, Chapter 5 is to be made in order that the Surveyor may satisfy himself as to its efficient state.

5.5.1(e) *Tank Examination*. During each Special Periodical Survey, the double bottom, deep, ballast, rake, cargo tanks/holds, adjacent void spaces, cofferdams, bilges, drain wells, machinery spaces and pump rooms are to be examined together with cargo piping, ballast piping, anodes and coatings. Precautions are to be taken to ensure safety during inspection. Tanks are to be thoroughly freed of dangerous gas or hazardous chemicals and cleaned sufficiently to reveal corrosion, deformation, fractures, damages or other structural deterioration. Means are to be provided for access to the upper parts of the tanks, as required for examination and thickness measurement.

For Oil Tank Barges, Fuel Oil Tank Barges and Chemical Tank Barges 122 meters (400 feet) and over in length, see Close-up Survey requirements in 7-3-2/5.13.4 for single hull Oil Tank Barges and Fuel Oil Tank Barges, 7-3-2/5.14.4 for double hull Oil Tank Barges and Fuel Oil Tank Barges and 7-3-2/5.21.4 for all Chemical Tank Barges.

5.5.1(f) *Thickness Measurements*

i) *Minimum Requirements for Barges other than Oil Tank Barges, Fuel Oil Tank Barges and Chemical Tank Barges (1 July 2005)*

Special Periodical Survey No. 1 and 2

- Areas considered suspect by the Surveyor, throughout the barge.

Special Periodical Survey No. 3

- Areas considered suspect by the Surveyor, throughout the barge.
- Two (2) transverse sections within the midship half length.

Special Periodical Survey No. 4 and Subsequent Special Periodical Surveys

- Areas considered suspect by the Surveyor, throughout the barge.
- Three (3) transverse sections within the midship half-length.
- Two (2) wind and water strakes, port and starboard, for the full length.
- All exposed main deck and superstructure deck plating.
- Flat keel plating full length, plus all bottom plating.

ii) *Minimum Requirements for Thickness Measurement for Oil Tank Barges, Fuel Oil Tank Barges and Chemical Tank Barges under 122 meters (400 feet) in length*

Special Periodical Survey No. 1 and 2

- Areas considered suspect by the Surveyor, throughout the barge.

Special Periodical Survey No. 3

- Areas considered suspect by the Surveyor, throughout the barge.
- Two (2) transverse sections within the midship half-length in way of two (2) different cargo (or ballast) tanks.

Special Periodical Survey No. 4 and Subsequent Special Periodical Surveys

- Areas considered suspect by the Surveyor, throughout the barge.
- Three (3) transverse sections within the midship half-length avoiding those tanks previously gauged.
- Transverse webs with associated plating and longitudinals in way of the three (3) transverse sections required above.
- All transverse bulkheads including stiffening system in all ballast and cargo tanks.
- Two (2) wind and water strakes, port and starboard, for the full length.
- All exposed main deck and superstructure deck plating.
- Flat keel plating full length, plus all bottom plating.

iii) *Minimum Requirements for Thickness Measurement for Oil Tank Barges, Fuel Oil Barges and Chemical Tank Barges 122 meters (400 feet) and over in length.* See 7-3-2/5.13.5 for single hull Oil Tank Barges and Fuel Oil Tank Barges, 7-3-2/5.14.3 for double hull Oil Tank Barges and Fuel Oil Tank Barges and 7-3-2/5.21.5 for all Chemical Tank Barges.

5.5.1(g) *Tank Testing (1 July 2001)*

i) *Barges other than Oil Tank Barges, Fuel Oil Tank Barges and Chemical Tank Barges (1 July 2005).* In lieu of 7-2-3/5.1.10, during each Special Periodical Survey of barges other than Oil Tank Barges, Fuel Oil Tank Barges and Chemical Tank Barges, double bottom, deep, ballast, rake and other tanks are to be tested with a head of liquid to the highest point that liquid will rise under service conditions. Alternative means of testing may be approved, provided the Surveyor is satisfied with the internal and external condition of the tanks and associated structure. The testing of double bottoms and other spaces not designed for the carriage of liquid may be omitted provided a satisfactory internal examination is carried out together with an examination of the tanktop and, in the opinion of the Surveyor, testing may be waived. These requirements are not applicable to independent cargo tanks and liquefied gas cargo tanks. For independent cargo tanks, refer to 7-3-2/5.1.12 and for liquefied gas cargo tanks, refer to 7-3-2/5.11.

ii) *All Oil Tank Barges, Fuel Oil Tank Barges and Chemical Tank Barges under 122 meters (400 feet) in Length and Double Hull Oil Tank Barges, Double Hull Fuel Oil Tank Barges and Double Hull Chemical Tank Barges 122 meters (400 feet) and over in Length (1 July 2010).* In lieu of 7-3-2/5.1.10, during each Special Periodical Survey, the cargo tank bulkheads which form the boundaries of segregated cargoes, or which face ballast tanks, void spaces, pipe tunnels, fuel oil tanks, pump rooms or cofferdams are to be tested with a head of liquid to the highest point the liquid will rise under service conditions for cargo tanks or top of air pipes for ballast tanks. The Surveyor is to be satisfied as to the condition of the remaining cargo-tank bulkheads by visual examination. However, at Special Periodical Survey No. 3 and subsequent Special Periodical Surveys, or when cargoes are intended to be carried without specified segregation, all bulkheads of cargo tanks are to be tested as above and reported upon. Alternative means of testing the cargo tanks such as air or hydro pneumatic testing may be approved, provided the Surveyor is satisfied with the internal and external condition of the tanks and associated structures, that there is no evidence of leakage, distortion or substantial corrosion that would affect the structural integrity of the tank.

iii) *(1 July 2010)* For Non Double Hull Oil Tank Barges and Non Double Hull Fuel Oil Tank Barges 122 meters (400 feet) and over in length, see Tank Testing requirements in 7-3-2/5.13.6.

iv) *(1 July 2010)* For Non-Double Hull Chemical Tank Barges 122 meters (400 feet) and over in length, see Tank Testing requirements in 7-3-2/5.21.6.

5.5.2 *Liquefied Gas Tank Barges (1 July 2005)*

In addition to the requirements of 7-3-2/5.5.1, a Special Periodical Survey is also to include the applicable requirements of 7-3-2/5.11.

5.7 Bulk Carriers – Non Double Skin ESP and Bulk Carrier Features of Combination Carriers – Non Double Skin ESP

In addition to the applicable requirements of 7-3-2/5.1, the Special Periodical Survey is to include the following:

5.7.1 Survey Planning (1 July 2006)

Survey planning meeting is to be held in accordance with 7-3-2/9.2.

Survey program is to be developed in accordance with 7-3-2/9.1.

5.7.2 General (1 July 2006)

The Special Periodical Survey is to include, in addition to the requirements of the Annual Survey, examination, tests and checks of sufficient extent to ensure that the hull and related piping, as required herein, are in a satisfactory condition and fit for the intended purpose for the new period of class of 5 years to be assigned, subject to proper maintenance and operation and to periodical surveys being carried out at the due dates.

5.7.3 Overall Survey Requirements (1 July 2006)

All cargo holds, ballast tanks, pipe tunnels, cofferdams and void spaces bounding cargo holds, decks and outer hull are to be examined. This examination is to be supplemented by thickness measurement and testing as required to ensure that the structural integrity remains effective. The aim of the examination is to discover substantial corrosion, significant deformation, fractures, damages or other structural deterioration, that may be present.

All piping systems within the above spaces are to be examined and operationally tested to working pressure to the satisfaction of the attending Surveyor to ensure that tightness and condition remain satisfactory.

5.7.3(a) Hatch Covers and Coamings (1 July 2008). A thorough examination of the items listed in 7-32/1.7.1 is to be carried out, in addition to all hatch covers and coamings.

Checking of the satisfactory operation of all mechanically operated hatch covers is to be made, including:

- Stowage and securing in open condition
- Proper fit and efficiency of sealing in closed condition
- Operational testing of hydraulic and power components, wires, chains and link drives

Checking the effectiveness of sealing arrangements of all hatch covers by hose testing or equivalent is to be carried out.

5.7.3(b) Extent of Overall Survey. An Overall Survey of all tanks and spaces is to be carried out.

Fuel oil, lube oil and fresh water tanks in the cargo length area are to be examined in accordance with 7-3-2/5.1.7(d).

5.7.4 Close-up Survey Requirements (1 July 2006)

The Surveyor may extend the Close-up Survey as deemed necessary taking into account the maintenance of the spaces under survey, the condition of the corrosion prevention system and where spaces have structural arrangements or details which have suffered defects in similar spaces or on similar vessels according to available information.

Close-up Survey of transverse bulkheads is to be carried out at the following levels:

- Immediately above the inner bottom and immediately above the line of gussets (if fitted) and shedders for ships without lower stools.
- Immediately above and below the lower stool shelf plate (for those ships fitted with lower stools) and immediately above the line of shedder plates.
- About mid-height of the bulkhead.
- Immediately below the upper deck plating and immediately adjacent to the upper wing tank, and immediately below the upper stool shelf plate for those ships fitted with upper stools, or immediately below the topside tank.

With reference to cargo and ballast history and coating arrangements, tanks and holds are to be selected for Close-up Survey which will provide the best representative sampling of areas likely to be most exposed to the effects of corrosion, swash and stress concentration.

For areas in spaces where hard protective coatings are found to be in GOOD condition, the extent of close-up surveys may be specially considered.

(1 July 2001) The survey extent of ballast tanks converted to void spaces is to be specially considered in relation to the requirements for ballast tanks. As a minimum, sufficient close-up inspection and thickness measurements are to be carried out to determine the actual average condition of the structure under the coating.

Minimum requirements for close-up survey at Special Periodical Survey are as follows.

5.7.4(a) Special Periodical Survey No. 1 (Age ≤ 5 years)

- i)* 25% of shell frames in the forward cargo hold at representative positions. Representative frames in remaining cargo holds. (See 7-A-6/Figure 3 Area A)
- ii)* One (1) transverse web with associated plating and longitudinals in two (2) representative ballast tanks of each type: topside or hopper side tanks. (See 7-A-6/Figure 3 Area B)
- iii)* Two (2) cargo hold transverse bulkheads plating, stiffeners and girders, including internal structure of upper and lower stools, where fitted. (See 7-A-6/Figure 3 Area C)
- iv)* (1 July 2016) All cargo hold hatch covers and coamings plating and stiffeners. For cargo hold hatch covers of approved design which structurally have no access to the internals, close-up survey/thickness measurement shall be done of accessible parts of hatch covers structures. (See 7-A-6/Figure 3 Area D)

5.7.4(b) Special Periodical Survey No. 2 (5 < Age ≤ 10 years)

- i)* (2003) All shell frames in the forward cargo hold and 25% of frames in each of the remaining cargo holds including upper and lower end attachments and adjacent shell plating.
(1 July 2007) For bulk carriers 100,000 DWT and above, all shell frames in the No. 1 forward cargo hold and 50% of shell frames in each of the remaining cargo holds, including upper and lower end attachments and adjacent shell plating. (See 7-A-6/Figure 3 Area A)
- ii)* One (1) transverse web with associated plating and longitudinals in all ballast tanks. (See 7-A-6/Figure 3 Area B)
- iii)* Forward and aft transverse bulkheads in one (1) topside ballast tank, including stiffening systems. (See 7-A-6/Figure 3 Area B)
- iv)* All cargo hold transverse bulkheads plating, stiffeners and girders, including internal structure of upper and lower stools, where fitted. (See 7-A-6/Figure 3 Area C)
- v)* (2003) All deck plating and under deck structure inside line of hatch openings between all cargo hold hatches. (See 7-A-6/Figure 3 Area E)
- vi)* (1 July 2016) All cargo hatch covers and coamings plating and stiffeners. For cargo hold hatch covers of approved design which structurally have no access to the internals, close-up survey/thickness measurement shall be done of accessible parts of hatch covers structures. (See 7-A-6/Figure 3 Area D)

5.7.4(c) Special Periodical Survey No. 3 (10 < Age ≤ 15 years)

- i)* (2005) All shell frames in the forward cargo hold and one other selected cargo hold, and 50% of frames in each of the remaining cargo holds, including the upper and lower end attachments and adjacent shell plating. (See 7-A-6/Figure 3 Area A)
- ii)* All transverse web with associated plating and longitudinals in all ballast tanks. (See 7-A-6/Figure 3 Area B)
- iii)* All transverse bulkheads in ballast tanks, including stiffening systems (See 7-A-6/Figure 3 Area B)

- iv) All cargo holds transverse bulkheads plating, stiffeners and girders, including internal structure of upper and lower stools, where fitted. (See 7-A-6/Figure 3 Area C)
- v) (2005) All deck plating and under deck structure inside the line of hatch openings between all cargo hold hatches. (See 7-A-6/Figure 3 Area E)
- vi) (1 July 2016) All cargo hatch covers and coamings plating and stiffeners. For cargo hold hatch covers of approved design which structurally have no access to the internals, close-up survey/thickness measurement shall be done of accessible parts of hatch covers structures. (See 7-A-6/Figure 3 Area D)

5.7.4(d) *Special Periodical Survey No. 4 and Subsequent Special Periodical Surveys (Age > 15 years)*

- i) All shell frames in all cargo holds including upper and lower end attachments and adjacent shell plating. (See 7-A-6/Figure 3 Area A)
- ii) All transverse webs with associated plating and longitudinals in all ballast tanks. (See 7-A-6/Figure 3 Area B)
- iii) All transverse bulkheads in ballast tanks, including stiffening systems (See 7-A-6/Figure 3 Area B)
- iv) All cargo holds transverse bulkheads plating, stiffeners and girders, including internal structure of upper and lower stools, where fitted. (See 7-A-6/Figure 3 Area C)
- v) (2005) All deck plating and under deck structure inside the line of hatch openings between all cargo hold hatches. (See 7-A-6/Figure 3 Area E)
- vi) (1 July 2016) All cargo hatch covers and coamings plating and stiffeners. For cargo hold hatch covers of approved design which structurally have no access to the internals, close-up survey/thickness measurement shall be done of accessible parts of hatch covers structures. (See 7-A-6/Figure 3 Area D)

5.7.5 Thickness Measurement Requirements (1 July 2013)

Where substantial corrosion is found, additional thickness measurements in accordance with 7-3-2/7 are to be taken to confirm the extent of substantial corrosion. These extended thickness measurements are to be carried out before the survey is credited as completed.

Suspect areas identified at previous surveys are to be examined. Areas of substantial corrosion identified at previous surveys are to have thickness measurements taken.

For vessels built under IACS Common Structural Rules, the identified substantial corrosion areas may be:

- i) Protected by coating applied in accordance with the coating manufacturer's requirements and examined at annual intervals to confirm the coating in way is still in GOOD condition, or alternatively
- ii) Required to be measured at annual intervals.

The Surveyor may require further thickness measurements, as deemed necessary.

Where hard protective coatings are found to be in GOOD condition, the extent of thickness measurements of structural members subject to close-up surveys may be specially considered.

Transverse sections are to be chosen where the largest reductions are suspected to occur or are revealed from deck plating measurements, one of which is to be in the amidships area.

Representative thickness measurement to determine both general and local levels of corrosion in the shell frames and their end attachments in all cargo holds and ballast tanks is to be carried out.

Thickness measurement is also to be carried out to determine the corrosion levels on the transverse bulkhead plating.

Minimum requirements for thickness measurement at Special Periodical Survey are as follows:

5.7.5(a) *Special Periodical Survey No. 1 (Age ≤ 5 years)*

- i) Suspect areas throughout the vessel.
- ii) Measurement, for general assessment and recording of corrosion patterns, of structural members subject to Close-up Survey.

5.7.5(b) *Special Periodical Survey No. 2 (5 < Age ≤ 10 years)*

- i) Suspect areas throughout the vessel.
- ii) All deck plating inside the line of opening between cargo hold hatches.
- iii) Two (2) transverse sections of deck plating outside the line of cargo hatch openings within the amidships $0.5L$.
- iv) Plates in two (2) wind-and-water strakes in way of the same transverse sections.
- v) Selected wind-and-water strakes outside the cargo length area.
- vi) All cargo hold hatch covers and coamings (plating and stiffeners)
- vii) Measurement, for general assessment and recording of corrosion patterns, of structural members subject to Close-up Survey.
- viii) (1 July 2003) Measurements of the corrugated transverse watertight bulkhead between cargo holds No's. one and two, for vessels subject to IACS UR S19 and IACS UR S23.
- ix) (2005) Additional thickness measurements to be taken of the cargo hold side shell frames and brackets on ships subject to compliance with IACS UR S31 for initial and continued compliance.

5.7.5(c) *Special Periodical Survey No. 3 (10 < Age ≤ 15 years)*

- i) Suspect areas throughout the vessel
- ii) All main deck plating within the cargo length area.
- iii) Two (2) transverse sections, one (1) in the amidship area, outside the line of cargo hatch openings within the amidships $0.5L$.
- iv) All plating in two (2) wind-and-water strakes, port and starboard, full length.
- v) All cargo hold hatch covers and coamings (plating and stiffeners).
- vi) Plating and stiffeners of transverse bulkheads.
- vii) Internals in forepeak and afterpeak tanks, including plating and stiffeners of bulkheads.
- viii) Measurement, for general assessment and recording of corrosion pattern, of structural members subject to Close-up Survey.
- ix) (1 July 2002) Measurements of the corrugated transverse watertight bulkhead between cargo holds No's. one and two, for vessels subject to IACS UR S19 and IACS UR S23.
- x) (2005) Additional thickness measurements to be taken of the cargo hold side shell frames and brackets on ships subject to compliance with IACS UR S31 for initial and continued compliance.

5.7.5(d) *Special Periodical Survey No. 4 and Subsequent Special Periodical Surveys (Age > 15 years)*

- i) Suspect areas throughout the vessel.
- ii) All main deck plating within the cargo length area, all exposed main deck plating outside of the cargo length area, and all exposed first tier superstructure deck plates (poop, bridge and forecastle decks).
- iii) A minimum of three (3) transverse sections, one (1) in the amidship area, outside of the line of cargo hatch openings within the amidships $0.5L$.

- iv) All plating in two (2) wind-and-water strakes, port and starboard, full length.
- v) All cargo hold hatch covers and coamings (plating and stiffeners).
- vi) Plating and stiffeners of transverse bulkheads
- vii) Internals in forepeak and afterpeak tanks, including plating and stiffeners of bulkheads.
- viii) Duct keel or pipe tunnel plating and internals.
- ix) All keel and bottom plates full length.
- x) (2003) Plating of seachests. Shell plating in way of overboard discharges as considered necessary by the attending Surveyor.
- xi) Measurement, for general assessment and recording of corrosion patterns of structural members subject to Close-up Survey.
- xii) (1 July 2002) Measurements of the corrugated transverse watertight bulkhead between cargo holds No's. one and two, for vessels subject to IACS UR S19 and IACS UR S23.
- xiii) (2005) Additional thickness measurements to be taken of the cargo hold side shell frames and brackets on ships subject to compliance with IACS UR S31 for initial and continued compliance.

5.7.6 Tank Testing Requirements (1 July 2004)

Boundaries of double bottom, deep, ballast and other tanks, including holds adapted for the carriage of water ballast, are to be tested in addition to and in accordance with 7-3-2/5.1.10.

5.7.7 Drydocking Requirements (1 July 2006)

In addition to the requirements of 7-3-2/5.1.2, the overall and close-up surveys and thickness measurements, as applicable, of the lower portions of the cargo holds and ballast tanks are to be carried out while the vessel is in drydock in accordance with the applicable requirements for Special Periodical Survey, if not already carried out.

Note: Lower portions of the cargo holds and ballast tanks are considered to be the parts below light ballast waterline.

5.7.8 Bulk Carriers subject to IACS Unified Requirement S31 (2004)

Side shell frames of cargo holds bounded by a single side shell are to be assessed for compliance with the requirements of IACS UR S31 and steel renewal, reinforcement or coating, where required in accordance with IACS UR S31, is to be carried out.

5.7.9 Bulk Carriers subject to SOLAS XII/12 and XII/13 (2007)

5.7.9(a) *Vessels complying with SOLAS XII/12.* Water ingress detection and alarm systems for cargo holds, ballast and dry spaces are to be examined and tested.

5.7.9(b) *Vessels complying with SOLAS XII/13.* Means for draining and pumping of tanks forward of the collision bulkhead and bilges of dry spaces any part of which extends forward of the foremost cargo hold, and their controls are to be examined and tested.

5.9 High Speed Craft

In addition to the applicable requirements of 7-3-2/5.1, the Special Periodical Survey is to include the following:

5.9.1 Requirements for Craft of FRP Construction

5.9.1(a) Engine foundations and their attachments to the hull are to be examined.

5.9.1(b) A minimum of five plugs, each two (2) inches in diameter, are to be removed from the hull bottom and topsides from locations deemed appropriate from the attending Surveyor and examined for core to skin adhesion and water permeation.

5.11 Liquefied Gas Carriers

(1 July 2006) In addition to the applicable requirements of 7-3-2/3.11.2 and 7-3-2/5.1, the Special Periodical Survey is to include the following:

5.11.1 Special Periodical Surveys No. 1 and No. 2

5.11.1(a) Cargo Tanks (Primary Containers). An internal examination is to be made of all cargo tanks, after being gas freed, including internal mountings and equipment.

5.11.1(b) Cargo Tank Supports, Insulation and Hull Structures (1 July 2006). For independent tanks, foundations, chocks, sway braces, keys, anti-flotation arrangements, the secondary barriers or hull plating or both are to be examined, with special attention being given to the cargo tanks and insulation in way of the above. See 7-3-2/5.11.1(f) for insulation removal. Framing adjacent to the cargo containment system is also to be examined.

Where the arrangement is such that the insulation cannot be examined, the surrounding structures in the wing tanks, double bottom tanks and cofferdams are to be examined for cold spots while the cargo tank is in cold condition, unless sufficient evidence of the integrity of the insulation is available from the voyage records.

5.11.1(c) Interbarrier Space Venting System (1 July 2003). Venting systems, relief valves or other arrangements provided for emergency removal of gas from the interbarrier spaces and hold spaces are to be opened, inspected, tested and readjusted as necessary.

5.11.1(d) Cargo Tank Venting System and Liquid-level Indicators (2001). Relief valves, liquid-level indicators and venting systems for the primary cargo containment system are to be examined. All relief valves are to be opened, inspected, tested and readjusted as necessary. If the cargo tanks are equipped with relief valves with non-metallic membranes in the main or pilot valves, such non-metallic membranes are to be replaced. Liquid-level indicators and alarms are to be proven satisfactory. Where a proper record of continuous overhaul and retesting of individually identifiable relief valves is maintained, consideration will be given to acceptance on the basis of opening, internal examination and testing of a representative sampling of valves including each size of each type of liquefied gas or vapor relief valve in use, provided there is logbook evidence that the remaining valves have been overhauled and tested since the crediting of the previous Special Periodical Survey. The testing and setting of relief valves may be carried out in place or after removal.

5.11.1(e) Cargo Handling and Piping Systems (1 July 2006). All piping, machinery and equipment for loading, unloading, venting, compressing, refrigerating, liquefying, heating or otherwise handling the liquefied gas or vapor and liquid nitrogen, and gas burning installations is to be examined including removal of insulation and opening for examination, as deemed necessary. Where deemed suspect, a hydrostatic test to 1.25 times the Maximum Allowable Relief Valve Setting (MARVS) for the pipeline is to be carried out. After reassembly, the complete piping is to be tested for leaks. Where water cannot be tolerated and the piping cannot be dried prior to putting the system into service, the Surveyor may accept alternative testing fluids or alternative means of testing. All emergency shut-down valves and remote operating valves in the cargo piping systems are to be inspected and proven operable. The pressure relief valves are to be function-tested. A random selection of valves is to be opened for examination and adjusted.

5.11.1(f) Insulation Removals (1 July 2006). Insulation is to be removed in way of any distorted or otherwise suspect insulation or structural part of the cargo tanks or elsewhere to carry out any of the examinations as required by the Surveyor.

5.11.1(g) Thickness Measurements. Where there is evidence of corrosion, or where one side of the cargo tank is exposed to possible corrosive atmosphere, the plating of the cargo tanks is to be gauged by nondestructive means to determine the thickness.

5.11.1(h) Cargo Pump Towers (2007). All cargo pump tower structures are to be examined including stiffeners, bracings, fasteners and locking devices, spray nozzles, wiring with associated conduits and pipe connections. Where deemed necessary by the Surveyor, dimensional measurements and/or nondestructive testing may be required. See also 7-3-2/5.11.1(j).

5.11.1(i) *Secondary Barriers (1 July 2014)*. The secondary barrier is to be checked for its effectiveness by means of a pressure/vacuum test, a visual inspection or other acceptable method.

For membrane containment systems, a tightness test of the primary and secondary barrier shall be carried out in accordance with the system designers' procedures and acceptance criteria as approved by ABS. Low differential pressure tests may be used for monitoring the cargo containment system performance, but are not considered an acceptable test for the tightness of the secondary barrier.

For membrane containment systems with glued secondary barriers if the designer's threshold values are exceeded, an investigation is to be carried out and additional testing such as thermographic or acoustic emissions testing should be carried out.

5.11.1(j) *Nondestructive Testing (2011)*

i) (1 July 2012) Nondestructive testing is to supplement cargo tank inspection with special attention to be given to the integrity of the main structural members, tank shell and highly stressed areas, including welded connections as deemed necessary by the Surveyor. However, for type C tanks, this does not mean that non-destructive testing can be dispensed with totally. The following items are, inter alia, considered as highly stressed areas:

- Cargo tank supports and anti-rolling/anti pitching devices.
- Web frames or stiffening rings.
- Y-connections between tank shell and a longitudinal bulkhead of bilobe tanks.
- Swash bulkhead boundaries.
- Dome and sump connections to the tank shell.
- Foundations for pumps, towers, ladders etc.
- Pipe connections.

ii) (2004) For independent tanks type C, in addition to the requirements of i) above, at alternate Special Periodical Surveys, at least 10% of the length of the welded connections in each highly stressed area is to be tested. This testing is to be carried out internally and externally, as applicable. Insulation is to be removed, as necessary, for the required nondestructive testing.

iii) For independent tanks type B, the extent of the nondestructive testing is to be in accordance with a planned program specially prepared and approved for the cargo tank design.

5.11.1(k) *Tank Testing*. Where nondestructive testing, or other evidence such as leakage or distortion, raises doubts as to the structural integrity of a cargo tank, a hydrostatic or hydropneumatic pressure test is to be carried out. For integral tanks and independent tanks type A and B, the test pressure is to be at least MARVS at the top of the tank. For independent tanks type C and pressurized tanks B with MARVS 2.06 bar (2.1 kgf/cm², 30 psi) and over, the test pressure is to be 1.25 times MARVS.

5.11.1(l) *Electrical Bonding*. Electrical bonding arrangements, including bonding straps where fitted, of the piping systems located within cargo tanks, ballast tanks, pipe tunnels, cofferdams and void spaces bounding cargo tanks are to be examined.

5.11.1(m) *Drainage Arrangements (1 July 2003)*. Systems for removing water or cargo from interbarrier spaces and holds are to be examined and tested as deemed necessary.

5.11.1(n) *Membrane and Semi-membrane Tank (1 July 2003)*. For membrane and semi-membrane tanks systems, inspection and testing are to be carried out in accordance with programs specially prepared in accordance with an approved method for the actual tank system.

5.11.1(o) *Gas-tight Bulkhead (1 July 2003)*. All gas-tight bulkheads are to be examined. The effectiveness of gas-tight shaft sealing is to be verified.

5.11.1(p) *Miscellaneous (1 July 2003)*. The hoses and spool pieces used for segregation of piping systems for cargo, inert gas and bilge are to be examined.

5.11.2 Special Periodical Survey No. 3 and Subsequent Special Periodical Surveys (1 July 2008)

In addition to all of the requirements of Special Periodical Survey No. 1 or 2, the following requirements are to be complied with for Special Periodical Survey No. 3 and all subsequent Special Periodical Surveys.

5.11.2(a) Cargo Tanks. The plating of at least one (1) cargo tank of gas carriers with independent tanks (LPG and LNG) is to be gauged by nondestructive means to determine the thickness. Where only cargoes of a non-corrosive nature are carried, modifications to the extent of thickness measurements may be specially considered.

5.11.3 Special Periodical Survey Close-Up Survey Requirements (1 July 2008)

5.11.3(a) Special Periodical Survey No. 1 (Age ≤ 5 years)

- i) One (1) complete transverse web frame including adjacent structural members in a representative ballast tank of the topside, hopper side and double hull side type.
- ii) One (1) transverse bulkhead lower part including girder system and adjacent structural members in a ballast tank.

5.11.3(b) Special Periodical Survey No. 2 (5 < Age ≤ 10 years)

- i) All complete transverse web frames including adjacent structural members in a ballast tank, which is to be a double hull side tank or a topside tank. If such tanks are not fitted, another ballast tank is to be selected.
- ii) One (1) complete transverse web frame including adjacent structural members in each remaining ballast tank.
- iii) One (1) transverse bulkhead lower part including girder system and adjacent structural members in each ballast tank.

5.11.3(c) Special Periodical Survey No. 3 and Subsequent Special Periodical Surveys (Age > 10 years)

- i) All complete transverse web frames, including adjacent structural members in all ballast tanks.
- ii) All transverse bulkheads lower part including girder system and adjacent structural members in all ballast tanks.

5.11.4 Drydocking Requirements (1 July 2008)

In addition to the requirements of 7-3-2/5.1.1, the overall and close-up surveys and thickness measurements, as applicable, of the lower portions of the ballast tanks are to be carried out while the vessel is in drydock in accordance with the applicable requirements for Special Periodical Survey, if not already carried out.

Note: Lower portions of the ballast tanks are considered to be the parts below light ballast waterline.

5.13 Tankers ESP (Oil Carriers and Oil Carrier Features of Combination Carriers – Non-Double Hull) (1 July 2006)

In addition to the applicable requirements of 7-3-2/5.1, the Special Periodical Survey is to include the following:

5.13.1 Survey Planning (1 July 2006)

Survey planning meeting is to be held in accordance with 7-3-2/9.2.

Survey program is to be developed in accordance with 7-3-2/9.1.

5.13.2 General (1 July 2006)

The Special Periodical Survey is to include, in addition to the requirements of the Annual Survey, examination, tests and checks of sufficient extent to ensure that the hull and related piping, as required herein, are in a satisfactory condition and fit for the intended purpose for the new period of class of 5 years to be assigned, subject to proper maintenance and operation and to periodical surveys being carried out at the due dates.

5.13.3 Overall Survey Requirements (1 July 2006)

All cargo tanks, ballast tanks, combined cargo/ballast tanks, including double bottom tanks, pump rooms, pipe tunnels, cofferdams and void spaces bounding cargo tanks, decks and outer hull are to be examined. This examination is to be supplemented by thickness measurement and testing as required, to ensure that the structural integrity remains effective. The aim of the examination is to discover substantial corrosion, significant deformation, fractures, damages or other structural deterioration, that may be present.

(2001) Cargo piping on deck, including Crude Oil Washing (COW) piping, and all piping systems within the above tanks and spaces are to be examined and operationally tested under working pressure to attending Surveyor's satisfaction to ensure that tightness and condition remain satisfactory. Special attention is to be given to ballast piping in cargo tanks and any cargo piping in ballast tanks and void spaces. Surveyors are to be advised on all occasions when this piping, including valves and fittings, is open during repair periods and can be examined internally.

Venting systems of cargo tanks, including secondary means of protection, are to be examined. All pressure/vacuum valves including flame arresting and drainage arrangements, are to be opened, cleaned, examined, tested and set in accordance with manufacturer's specifications, as applicable.

5.13.3(a) *Conditions of Coating.* Where provided, the condition of the corrosion prevention system of cargo tanks is to be examined.

5.13.3(b) *Ballast Tanks and Combined Cargo/Ballast Tanks (2010).* A ballast tank or a combined cargo/ballast tank is to be examined at subsequent annual intervals where:

- i) A hard protective coating has not been applied from the time of construction, or
- ii) A soft or semi-hard coating has been applied, or
- iii) Substantial corrosion is found within the tank, or
- iv) The hard protective coating is found to be in less than GOOD condition and the hard protective coating is not repaired to the satisfaction of the Surveyor.

Thickness measurements are to be carried out as deemed necessary by the Surveyor.

5.13.3(c) *Extent of Overall Survey.* An overall survey of all tanks and spaces is to be carried out.

5.13.4 Close-up Survey Requirements (1 July 2006)

The Surveyor may extend the Close-up Survey as deemed necessary, taking into account the maintenance of the tanks under survey, the condition of the corrosion prevention system, with particular attention being given to the following situations:

- Tanks having structural arrangements or details which have suffered defects in similar tanks or on similar ships according to available information.
- In tanks which have structures approved with reduced scantlings due to an approved corrosion control system.

With reference to cargo and ballast history and coating arrangements, tanks and holds are to be selected for Close-up Survey which will provide the best representative sampling of areas likely to be most exposed to the effects of corrosion, swash and stress concentration.

Close-up Surveys are to include welded attachments and deck transverse when fitted on the deck.

For areas in tanks where hard protective coatings are found to be in GOOD condition, the extent of Close-up Surveys may be specially considered.

Minimum requirements for Close-up Survey at Special Periodical Survey are as follows.

For further structural details, see 7-A-7/Figures 1-5.

5.13.4(a) *Special Periodical Survey No. 1 (Age ≤ 5 years)*

- i) One (1) complete transverse web frame ring including adjacent structural members in a ballast wing tank, if any, or in a cargo wing tank used primarily for water ballast. (See 7-A-7/Figure 5 Area A)
- ii) One (1) deck transverse including adjacent structural members in a cargo wing tank. (See 7-A-7/Figure 5 Area B)
- iii) Lower part of one (1) transverse bulkhead including girder system and adjacent structural members:
 - In one (1) ballast wing tank.
 - In one (1) cargo wing tank.
 - In one (1) cargo center tank.(See 7-A-7/Figure 5 Area D)

5.13.4(b) *Special Periodical Survey No. 2 (5 < Age ≤ 10 years)*

- i) All complete transverse web frame rings including adjacent structural members in a ballast wing tank, if any, or a cargo wing tank used primarily for water ballast. (See 7-A-7/Figure 5 Area A)
- ii) One (1) deck transverse including adjacent deck structural members.
 - In each of the remaining ballast tanks, if any.
 - In one (1) cargo wing tank.
 - In two (2) cargo center tanks.(See 7-A-7/Figure 5 Area B)
- iii) Both transverse bulkheads including girder system and adjacent structural members in a ballast wing tank, if any, or a cargo wing tank used primarily for water ballast. (See 7-A-7/Figure 5 Area C)
- iv) Lower part of one (1) transverse bulkhead including girder system and adjacent structural members.
 - In each remaining ballast tank.
 - In one (1) cargo wing tank.
 - In two (2) cargo center tanks.(See 7-A-7/Figure 5 Area D)

5.13.4(c) *Special Periodical Survey No. 3 (10 < Age ≤ 15 years)*

- i) All complete transverse web frame rings, including adjacent structural members in all ballast tanks and in a cargo wing tank. (See 7-A-7/Figure 5 Area A)
- ii) A minimum of 30% of all complete transverse web frame rings, including adjacent structural members in each remaining cargo wing tank. (See 7-A-7/Figure 5 Area A) (In calculating the 30% minimum, the number of web frame rings is to be rounded up to the next whole integer.)
- iii) A minimum of 30% of deck and bottom transverses including adjacent structural members in each cargo center tank. (See 7-A-7/Figure 5 Area E) (In calculating the 30% minimum, the number of transverses is to be rounded up to the next whole integer.)
- iv) All transverse bulkheads, including girder and stiffener systems and adjacent structural members in all cargo and ballast tanks. (See 7-A-7/Figure 5 Area C)
- v) Additional complete transverse web frame rings as considered necessary by the Surveyor. (See 7-A-7/Figure 5 Areas A and E)

5.13.4(d) Special Periodical Survey No. 4 and Subsequent Special Periodical Surveys (Age > 15 years)

- i)* All complete transverse web frame rings including adjacent structural members in all ballast tanks and in a cargo wing tank. (See 7-A-7/Figure 5 Area A)
- ii)* A minimum of 30% of all complete transverse web frame rings including adjacent structural members in each remaining cargo wing tank. (See 7-A-7/Figure 5 Area A) (In calculating the 30% minimum, the number of web frame rings is to be rounded up to the next whole integer.)
- iii)* A minimum of 30% of deck and bottom transverses including adjacent structural members in each cargo center tank. (See 7-A-7/Figure 5 Area E) (In calculating the 30% minimum, the number of transverses is to be rounded up to the next whole integer.)
- iv)* All transverse bulkheads including girder and stiffener systems and adjacent structural members in all cargo and ballast tanks. (See 7-A-7/Figure 5 Area C)
- v)* Additional complete transverse web frame rings as considered necessary by the Surveyor. (See 7-A-7/Figure 5 Areas A and E)
- vi)* Any additional tanks and structure as considered necessary by the Surveyor.

5.13.5 Thickness Measurement Requirements (1 July 2006)

In the case of oil tankers of 130 m (427 ft) in length and upwards (as defined in the International Convention of Load Lines in force) and more than 10 years of age, for the evaluation of the vessel's longitudinal strength as required in 7-3-2/15.1.2, the sampling method of thickness measurements is given in 7-A-4/33.

Where substantial corrosion is found, additional thickness measurements in accordance with 7-3-2/7 are to be taken to confirm the extent of substantial corrosion. These extended thickness measurements are to be carried out before the survey is credited as completed.

Suspect areas identified at previous surveys are to be examined. Areas of substantial corrosion identified at previous surveys are to have thickness measurements taken.

The Surveyor may require further thickness measurements, as deemed necessary.

Where hard protective coatings are found to be in GOOD condition, the extent of thickness measurements of structural members subject to Close-up Surveys may be specially considered.

Transverse sections are to be chosen where the largest reductions are suspected to occur or are revealed from deck plating measurements.

Minimum requirements for Thickness Measurement at Special Periodical Survey are as follows:

5.13.5(a) Special Periodical Survey No. 1 (Age ≤ 5 years)

- i)* Suspect areas throughout the vessel.
- ii)* One (1) transverse section of deck plating for the full beam of the ship within amidships 0.5L, in way of a ballast tank, if any, or a cargo tank used primarily for water ballast.
- iii)* Measurement, for general assessment and recording of corrosion patterns, of structural members subject to Close-up Surveys.

5.13.5(b) Special Periodical Survey No. 2 (5 < Age ≤ 10 years)

- i)* Suspect areas throughout the vessel.
- ii)* All main deck plating within the amidships 0.5L or cargo area, whichever is longer.
- iii)* One (1) transverse section within the amidships 0.5L.
- iv)* Plating in two (2) wind-and-water strakes outside amidships 0.5L.
- v)* Internals in forepeak and afterpeak tanks, including plating and stiffeners of forepeak and afterpeak tank bulkheads.
- vi)* Measurement for general assessment and recording of corrosion patterns of structural members subject to Close-up Survey.

5.13.5(c) *Special Periodical Survey No. 3 (10 < Age ≤ 15 years)*

- i) Suspect areas throughout the vessel.
- ii) All main deck plating within the amidships 0.5L or cargo area, whichever is longer.
- iii) Two (2) transverse sections, including at least one (1) in way of a ballast tank, within the amidships 0.5L.
- iv) All plating in two (2) wind-and-water strakes, port and starboard, full length.
- v) Internals in forepeak and afterpeak tanks, including plating and stiffeners of forepeak and afterpeak tank bulkheads.
- vi) Measurement, for general assessment and recording of corrosion patterns, of structural members subject to Close-up Survey.

5.13.5(d) *Special Periodical Survey No. 4 and Subsequent Special Periodical Surveys (Age > 15 years)*

- i) Suspect areas throughout the vessel.
- ii) All main deck plating within the cargo area, all exposed main deck plating outside of cargo area and all exposed 1st tier superstructure deck plating (poop, bridge and forecastle decks).
- iii) A minimum of three (3) transverse sections, including at least one (1) in way of a ballast tank, within the amidships 0.5L.
- iv) All plating in two (2) wind-and-water strakes, port and starboard, full length.
- v) Internals in forepeak and afterpeak tanks, including plating and stiffeners of forepeak and afterpeak tank bulkheads.
- vi) Duct keel or pipe tunnel plating and internals.
- vii) All keel and bottom plating, full length.
- viii) (2003) Plating of seachests. Shell plating in way of overboard discharges as considered necessary by the attending Surveyor.
- ix) Measurements, for general assessment and recording of corrosion patterns, of structural members subject to Close-up Survey.

5.13.6 Extent of Tank Testing (1 July 2014)

In addition to 7-3-2/5.1.10, tank testing requirements at Special Periodical Survey are as follows:

5.13.6(a) *Special Periodical Survey No. 1 (Age ≤ 5 years)*

- i) All ballast tank boundaries.
- ii) Cargo tank boundaries facing ballast tanks, void spaces, pipe tunnels, fuel oil tanks, pump rooms or cofferdams.

5.13.6(b) *Special Periodical Survey No. 2 and Subsequent Special Periodical Surveys (Age > 5 years)*

- i) All ballast tank boundaries.
- ii) All cargo tank bulkheads.

Note: All minimum requirements for cargo tank testing at Special Survey are given in 7-3-2/5.13.6(a) and 7-3-2/5.13.6(b) above. Cargo tank testing carried out by the vessel's crew under the direction of the Master may be accepted by the Surveyor provided the following conditions are complied with:

- i) (1 July 2016) A tank testing procedure, specifying fill heights, for tanks and bulkheads being tested, has been submitted by the owner and reviewed by the Surveyor prior to the testing being carried out;
- ii) There is no record of leakage, distortion or substantial corrosion that would affect the structural integrity of the tank;
- iii) The tank testing has been satisfactorily carried out within special survey window not more than 3 months prior to the date of the survey on which the overall or close up survey is completed;

- iv) The satisfactory results of the testing is recorded in the vessel's logbook;
- v) The internal and external condition of the tanks and associated structure are found satisfactory by the Surveyor at the time of the overall and close up survey.

5.13.7 Drydocking Requirements (1 July 2006)

In addition to the requirements of 7-3-2/5.1.2, the overall and Close-up Surveys and thickness measurements, as applicable, of the lower portions of the cargo tanks and ballast tanks are to be carried out while the vessel is in drydock in accordance with the applicable requirements for Special Periodical Survey, if not already carried out.

Note: Lower portions of the cargo and ballast tanks are considered to be the parts below light ballast waterline.

5.14 Tankers ESP (Oil Carriers and Oil Carrier Features of Combination Carriers – Double Hull) (2003)

In addition to the applicable requirements of 7-3-2/5.1, the Special Periodical Survey is also to include the following:

5.14.1 Survey Planning (1 July 2006)

Survey planning meeting is to be held in accordance with 7-3-2/9.2.

Survey program is to be developed in accordance with 7-3-2/9.1.

5.14.2 General (1 July 2006)

The Special Periodical Survey is to include, in addition to the requirements of the Annual Survey, examination, tests and checks of sufficient extent to ensure that the hull and related piping, as required herein, are in a satisfactory condition and fit for the intended purpose for the new period of class of 5 years to be assigned, subject to proper maintenance and operation and to periodical surveys being carried out at the due dates.

5.14.3 Overall Survey Requirements (1 July 2006)

All cargo tanks, ballast tanks, combined cargo/ballast tanks, including double bottom tanks, pump rooms, pipe tunnels, cofferdams and void spaces bounding cargo tanks, decks and outer hull are to be examined. This examination is to be supplemented by thickness measurement and testing as required, to ensure that the structural integrity remains effective. The aim of the examination is to discover substantial corrosion, significant deformation, fractures, damages or other structural deterioration, that may be present.

Cargo piping on deck, including Crude Oil Washing (COW) piping, and all piping systems within the above tanks and spaces are to be examined and operationally tested under working pressure to attending Surveyor's satisfaction to ensure that tightness and condition remain satisfactory. Special attention is to be given to ballast piping in cargo tanks and any cargo piping in ballast tanks and void spaces. Surveyors are to be advised on all occasions when this piping, including valves and fittings, is open during repair periods and can be examined internally.

Venting systems of cargo tanks, including secondary means of protection, are to be examined. All pressure/vacuum valves including flame arresting and drainage arrangements, are to be opened, cleaned, examined, tested and set in accordance with manufacturer's specifications, as applicable.

5.14.3(a) Conditions of Coating. Where provided, the condition of the corrosion prevention system of cargo tanks is to be examined.

5.14.3(b) Ballast Tanks and Combined Cargo/Ballast Tanks (2010). A ballast tank or a combined cargo/ballast tank is to be examined at subsequent annual intervals where:

- i) A hard protective coating has not been applied from the time of construction, or
- ii) A soft or semi-hard coating has been applied, or
- iii) Substantial corrosion is found within the tank, or
- iv) The hard protective coating is found to be in less than GOOD condition and the hard protective coating is not repaired to the satisfaction of the Surveyor.

Thickness measurements are to be carried out as deemed necessary by the Surveyor.

5.14.3(c) *Extent of Overall Survey.* An overall survey of all tanks and spaces is to be carried out.

5.14.4 Close-up Survey Requirements (1 July 2006)

The Surveyor may extend the Close-up Survey, as deemed necessary, taking into account the maintenance of the tanks under survey, the condition of the corrosion prevention system, with particular attention being given to the following situations:

- Tanks having structural arrangements or details which have suffered defects in similar tanks or on similar ships according to available information.
- In tanks which have structures approved with reduced scantlings due to an approved corrosion control system.

With reference to cargo and ballast history and coating arrangements, tanks and holds are to be selected for Close-up Survey which will provide the best representative sampling of areas likely to be most exposed to the effects of corrosion, swash and stress concentration.

Close-up Surveys are to include welded attachments and deck transverse when fitted on the deck.

For areas in tanks where hard protective coatings are found to be in GOOD condition, the extent of Close-up Surveys may be specially considered.

Minimum requirements for Close-up Survey at Special Periodical Survey are as follows.

For further structural details, see 7-A-13/Figures 1-5.

5.14.4(a) *Special Periodical Survey No. 1 (Age ≤ 5 years)*

- i) One (1) web frame⁽¹⁾ in one (1) ballast tank⁽²⁾. (See 7-A-13/Figure 4 Area 1.)
- ii) One (1) deck transverse⁽³⁾ in a cargo tank (See 7-A-13/Figure 4 Area 2.)
- iii) One (1) transverse bulkhead⁽⁴⁾ in one (1) ballast tank⁽²⁾. (See 7-A-13/Figure 4 Area 4.)
- iv) Lower part of a transverse bulkhead⁽⁵⁾ in one (1) cargo center tank⁽⁶⁾. (See 7-A-13/Figure 4 Area 5.)
- v) Lower part of a transverse bulkhead⁽⁵⁾ in one (1) cargo wing tank. (See 7-A-13/Figure 4 Area 5.)

5.14.4(b) *Special Periodical Survey No. 2 (5 < Age ≤ 10 years)*

- i) All web frames⁽¹⁾ in one (1) ballast tank⁽²⁾. (See 7-A-13/Figure 4 Area 1.)
- ii) The knuckle area and the upper part (5 meters approximately)⁽⁷⁾ of one (1) web frame in each remaining ballast tank. (See 7-A-13/Figure 5 Area 6.)
- iii) One (1) deck transverse⁽³⁾ in two (2) cargo tanks. (See 7-A-13/Figure 4 Area 2.)
- iv) One (1) transverse bulkhead⁽⁴⁾ in all ballast tanks. (See 7-A-13/Figure 4 Area 4.)
- v) Lower part of a transverse bulkhead⁽⁵⁾ in two (2) cargo center tanks⁽⁶⁾. (See 7-A-13/Figure 4 Area 5.)
- vi) Lower part of a transverse bulkhead⁽⁵⁾ in one (1) cargo wing tank. (See 7-A-13/Figure 4 Area 5.)

5.14.4(c) *Special Periodical Survey No. 3 (10 < Age ≤ 15 years)*

- i) All web frames⁽¹⁾ in all ballast tanks. (See 7-A-13/Figure 4 Area 1.)
- ii) All web frames⁽⁸⁾ in one (1) cargo tank. (See 7-A-13/Figure 5 Area 7.)
- iii) One (1) web frame⁽⁸⁾ in each remaining cargo tank. (See 7-A-13/Figure 5 Area 7.)
- iv) All transverse bulkheads⁽⁹⁾ in all cargo tanks. (See 7-A-13/Figure 4 Area 3.)
- v) All transverse bulkheads⁽⁴⁾ in all ballast tanks. (See 7-A-13/Figure 4 Area 4.)

5.14.4(d) *Special Periodical Survey No. 4 and Subsequent Special Periodical Surveys (Age > 15 years)*

- i) All web frames⁽¹⁾ in all ballast tanks. (See 7-A-13/Figure 4 Area 1.)
- ii) All web frames⁽⁸⁾ in one (1) cargo tank. (See 7-A-13/Figure 5 Area 7.)
- iii) One (1) web frame⁽⁸⁾ in each remaining cargo tank. (See 7-A-13/Figure 5 Area 7.)
- iv) All transverse bulkheads⁽⁹⁾ in all cargo tanks. (See 7-A-13/Figure 4 Area 3.)
- v) All transverse bulkheads⁽⁴⁾ in all ballast tanks. (See 7-A-13/Figure 4 Area 4.)
- vi) Additional transverse areas as deemed necessary by the Surveyor.

Notes:

- 1 Web frame in a ballast tank means vertical web in side tank, hopper web in hopper tank, floor in double bottom tank and deck transverse in double deck tank where fitted, including adjacent structural members. In fore and aft peak tanks, web frame means a complete transverse web frame ring including adjacent structural members.
- 2 A ballast tank means double bottom tank plus double side tank plus double deck tank, as applicable, even if these tanks are separate.
- 3 Deck transverse includes adjacent deck structural members or external structure on deck in way of the tank, where applicable.
- 4 Transverse bulkhead in a ballast tank includes girder system and adjacent structural members such as longitudinal bulkheads, girders in double bottom tanks, inner bottom plating, hopper side, inner hull longitudinal bulkhead and connecting brackets.
- 5 Transverse bulkhead lower part in a cargo tank includes girder system, adjacent structural members such as longitudinal bulkheads, and internal structure of lower stool, where fitted.
- 6 Where no center cargo tanks are fitted (as in the case of center longitudinal bulkhead), transverse bulkheads in port and starboard cargo wing tanks are to be surveyed.
- 7 Knuckle area is the area of the web frame around the connections of the slope hopper plating to the inner hull bulkhead and the inner bottom plating, up to 2 meters from the corners both on the bulkhead and the double bottom. The knuckle area and the upper part (5 meters approximately) include adjacent structural members.
- 8 Web frame in a cargo tank means deck transverse, longitudinal bulkhead vertical girder and cross ties, where fitted, including adjacent structural members.
- 9 Transverse bulkhead in a cargo tank includes girder system, adjacent structural members such as longitudinal bulkheads, and internal structure of lower and upper stools, where fitted.

5.14.5 *Thickness Measurement Requirements (1 July 2006)*

In the case of oil tankers of 130 m (427 ft) in length and upwards (as defined in the International Convention of Load Lines in force) and more than 10 years of age, for the evaluation of the vessel's longitudinal strength as required in 7-3-2/15.1.2, the sampling method of thickness measurements is given in 7-A-4/33.

Where substantial corrosion is found, additional thickness measurements in accordance with 7-3-2/7 are to be taken to confirm the extent of substantial corrosion. These extended thickness measurements are to be carried out before the survey is credited as completed.

Suspect areas identified at previous surveys are to be examined. Areas of substantial corrosion identified at previous surveys are to have thickness measurements taken.

The Surveyor may require further thickness measurements, as deemed necessary.

Where hard protective coatings are found to be in GOOD condition, the extent of thickness measurements of structural members subject to close-up surveys may be specially considered.

Transverse sections are to be chosen where the largest reductions are suspected to occur or are revealed from deck plating measurements.

Minimum requirements for Thickness Measurement at Special Periodical Survey are as follows:

5.14.5(a) Special Periodical Survey No. 1 (Age ≤ 5 years)

- i) Suspect areas throughout the vessel.
- ii) One (1) transverse section of deck plating for the full beam of the ship within amidships 0.5L, in way of a ballast tank, if any.
- iii) Measurement, for general assessment and recording of corrosion patterns, of structural members subject to Close-up Surveys.

5.14.5(b) Special Periodical Survey No. 2 (5 < Age ≤ 10 years)

- i) Suspect areas throughout the vessel.
- ii) All main deck plating within the amidships 0.5L or cargo area, whichever is longer.
- iii) One (1) transverse section within the amidships 0.5L.
- iv) Plating in two (2) wind-and-water strakes outside amidships 0.5L.
- v) Internals in forepeak and afterpeak tanks, including plating and stiffeners of forepeak and afterpeak tank bulkheads.
- vi) Measurement, for general assessment and recording of corrosion patterns, of structural members subject to Close-up Survey.

5.14.5(c) Special Periodical Survey No. 3 (10 < Age ≤ 15 years)

- i) Suspect areas throughout the vessel.
- ii) All main deck plating within the amidships 0.5L or cargo area, whichever is longer.
- iii) Two (2) transverse sections, including at least one (1) in way of a ballast tank, within the amidships 0.5L.
- iv) All plating in two (2) wind-and-water strakes, port and starboard, full length.
- v) Internals in forepeak and afterpeak tanks, including plating and stiffeners of forepeak and afterpeak tank bulkheads.
- vi) Measurement, for general assessment and recording of corrosion patterns, of structural members subject to Close-up Survey.

5.14.5(d) Special Periodical Survey No. 4 and Subsequent Special Periodical Surveys (Age > 15 years)

- i) Suspect areas throughout the vessel.
- ii) All main deck plating within the cargo area, all exposed main deck plating outside of cargo area and all exposed 1st tier superstructure deck plating (poop, bridge and forecastle decks).
- iii) A minimum of three (3) transverse sections, including at least one (1) in way of a ballast tank, within the amidships 0.5L.
- iv) All plating in two (2) wind-and-water strakes, port and starboard, full length.
- v) Internals in forepeak and afterpeak tanks, including plating and stiffeners of forepeak and afterpeak tank bulkheads.
- vi) Duct keel or pipe tunnel plating and internals.
- vii) All keel and bottom plating full length.
- viii) (2003) Plating of seachests. Shell plating in way of overboard discharges as considered necessary by the attending Surveyor.
- ix) Measurements, for general assessment and recording of corrosion patterns, of structural members subject to Close-up Survey.

5.14.6 Extent of Tank Testing (1 July 2014)

In addition to 7-3-2/5.1.10, tank testing requirements at Special Periodical Survey are as follows:

5.14.6(a) Special Periodical Survey No. 1 (Age ≤ 5 years)

- i) All ballast tank boundaries.
- ii) Cargo tank boundaries facing ballast tanks, void spaces, pipe tunnels, fuel oil tanks, pump rooms or cofferdams.

5.14.6(b) Special Periodical Survey No. 2 and Subsequent Special Periodical Surveys (Age > 5 years)

- i) All ballast tank boundaries.
- ii) All cargo tank bulkheads.

Note: All minimum requirements for cargo tank testing at Special Survey are given in 7-3-2/5.14.6(a) and 7-3-2/5.14.6(b) above. Cargo tank testing carried out by the vessel's crew under the direction of the Master may be accepted by the Surveyor provided the following conditions are complied with:

- i) (1 July 2016) A tank testing procedure, specifying fill heights, for tanks and bulkheads being tested, has been submitted by the owner and reviewed by the Surveyor prior to the testing being carried out;
- ii) There is no record of leakage, distortion or substantial corrosion that would affect the structural integrity of the tank;
- iii) The tank testing has been satisfactorily carried out within special survey window not more than 3 months prior to the date of the survey on which the overall or close up survey is completed;
- iv) The satisfactory results of the testing is recorded in the vessel's logbook;
- v) The internal and external condition of the tanks and associated structure are found satisfactory by the Surveyor at the time of the overall and close up survey.

5.14.7 Drydocking Requirements (1 July 2006)

In addition to the requirements of 7-3-2/5.1.2, the overall and close-up surveys and thickness measurements, as applicable, of the lower portions of the cargo tanks and ballast tanks are to be carried out while the vessel is in drydock in accordance with the applicable requirements for Special Periodical Survey, if not already carried out.

Note: Lower portions of the cargo and ballast tanks are considered to be the parts below light ballast waterline.

5.15 General Dry Cargo Vessels (ESDC) (2004)

(1 July 2004) In addition to the applicable requirements of 7-3-2/5.1, the Special Periodical Survey is also to include the following:

5.15.1 Survey Planning (1 July 2006)

Survey planning is to be carried out in accordance with 7-3-2/10.1.

5.15.2 General (1 July 2006)

The Special Periodical Survey is to include, in addition to the requirements of the Annual Surveys, examination, tests and checks of sufficient extent to ensure that the hull and related piping as required herein, are in a satisfactory condition and fit for the intended purpose for the new period of class of 5 years to be assigned, subject to proper maintenance and operation and to periodical surveys being carried out at the due dates.

5.15.3 Overall Survey Requirements (1 July 2006)

All cargo holds, ballast tanks, including double bottom tanks, pipe tunnels, cofferdams and void spaces bounding cargo holds, decks and outer hull are to be examined, and this examination is to be supplemented by thickness measurement and testing as required to ensure that the structural integrity remains effective.

The aim of the examination is to discover substantial corrosion, significant deformation, fractures, damages or other structural deterioration, that may be present.

All piping systems within the above spaces are to be examined and operationally tested to working pressure to the satisfaction of the Surveyor to ensure that tightness and condition remain satisfactory.

The survey extent of ballast tanks converted to void spaces is to be specially considered in relation to the requirements for ballast tanks.

5.15.3(a) Hatch Covers and Coamings. A thorough examination of the items listed in 7-3-2/1.15.1 is to be carried out.

Checking of the satisfactory operation of all mechanically operated hatch covers is to be made, including:

- Stowage and securing in open condition
- Proper fit and efficiency of sealing in closed condition
- Operational testing of hydraulic and power components, wires, chains and link drives

Checking the effectiveness of sealing arrangements of all hatch covers by hose testing or equivalent is to be carried out.

5.15.3(b) Extent of Overall Survey. An overall survey of all tanks and spaces is to be carried out.

Fuel oil, lube oil and fresh water tanks in the cargo length area are to be examined in accordance with 7-3-2/5.1.7(d).

5.15.4 Close-up Survey Requirements (1 July 2006)

The Surveyor may extend the close-up survey as deemed necessary taking into account the maintenance of the spaces under survey, the condition of the corrosion prevention system and where spaces have structural arrangements or details which have suffered defects in similar spaces or on similar vessels according to available information.

Close-up Survey of transverse bulkheads is to be carried out at the following levels:

- Immediately above the inner bottom and immediately above the tween decks, as applicable.
- Mid-height of the bulkheads for holds without tween decks.
- Immediately below the main deck plating and immediately below the tween deck plating.

For areas in spaces where hard protective coatings are found to be in GOOD condition, the extent of Close-up Surveys may be specially considered.

The survey extent of ballast tanks converted to void spaces is to be specially considered in relation to the requirements for ballast tanks. As a minimum, sufficient close-up inspection and thickness measurements are to be carried out to determine the actual average condition of the structure under coating.

Minimum requirements for close-up survey at Special Periodical Survey are as follows:

5.15.4(a) Special Periodical Survey No. 1 (Age ≤ 5 years)

- i)* Selected transverse shell frames in one (1) forward and one (1) aft cargo hold and associated tween deck spaces. (See 7-A-6/Figure 4 Area A.)
- ii)* One (1) selected cargo hold transverse bulkhead, including plating, stiffeners and girders. (See 7-A-6/Figure 4 Area B.)
- iii)* (1 July 2016) All cargo hold hatch covers and coamings (plating and stiffeners). For cargo hold hatch covers of approved design which structurally have no access to the internals, close-up survey/thickness measurement shall be done of accessible parts of hatch covers structures. (See 7-A-6/Figure 4 Area D.)

5.15.4(b) *Special Periodical Survey No. 2 (5 < Age ≤ 10 years)*

- i) Selected transverse shell frames in all cargo holds and tween deck spaces. (See 7-A-6/Figure 4 Area A.)
- ii) One (1) transverse bulkhead in each cargo hold, including bulkhead plating, stiffeners and girders. (See 7-A-6/Figure 4 Area B.)
- iii) Forward and aft transverse bulkhead in one (1) side ballast tank, including stiffening system. (See 7-A-6/Figure 4 Area B.)
- iv) One (1) transverse web with associated plating and framing in two (2) representative ballast tanks of each type (i.e., topside, hopper side, side tank or double bottom tank). (See 7-A-6/Figure 4 Area C.)
- v) (1 July 2016) All cargo hold hatch covers and coamings (plating and stiffeners). For cargo hold hatch covers of approved design which structurally have no access to the internals, close-up survey/thickness measurement shall be done of accessible parts of hatch covers structures. (See 7-A-6/Figure 4 Area D.)
- vi) Selected areas of all deck plating and underdeck structure inside line of hatch openings between cargo hold hatches. (See 7-A-6/Figure 4 Area E.)
- vii) Selected areas of inner bottom plating. (See 7-A-6/Figure 4 Area F)

5.15.4(c) *Special Periodical Survey No. 3 (10 < Age ≤ 15 years)*

- i) All transverse shell frames in the forward lower cargo hold and 25% frames in each of the remaining cargo holds and tween deck spaces, including upper and lower end attachments and adjacent shell plating. (See 7-A-6/Figure 4 Area A.)
- ii) All cargo hold transverse bulkheads, including bulkhead plating, stiffeners and girders. (See 7-A-6/Figure 4 Area B.)
- iii) All transverse bulkheads in ballast tanks, including stiffening system. (See 7-A-6/Figure 4 Area B.)
- iv) All transverse webs with associated plating and framing in all ballast tanks. (See 7-A-6/Figure 4 Area C.)
- v) (1 July 2016) All cargo hold hatch covers and coamings (plating and stiffeners). For cargo hold hatch covers of approved design which structurally have no access to the internals, close-up survey/thickness measurement shall be done of accessible parts of hatch covers structures. (See 7-A-6/Figure 4 Area D.)
- vi) All deck plating and underdeck structure inside line of hatch openings between cargo hold hatches. (See 7-A-6/Figure 4 Area E.)
- vii) All areas of inner bottom plating. (See 7-A-6/Figure 4 Area F)

5.15.4(d) *Special Periodical Survey No. 4 and Subsequent Special Periodical Surveys (Age > 15 years)*

- i) All transverse shell frames in all cargo holds and tween deck spaces, including upper and lower end attachments and adjacent shell plating. (See 7-A-6/Figure 4 Area A.)
- ii) All cargo hold transverse bulkheads, including bulkhead plating, stiffeners and girders. (See 7-A-6/Figure 4 Area B.)
- iii) All transverse bulkheads in ballast tanks, including stiffening system. (See 7-A-6/Figure 4 Area B.)
- iv) All transverse webs with associated plating and framing in all ballast tanks. (See 7-A-6/Figure 4 Area C.)

- v) (1 July 2016) All cargo hold hatch covers and coamings (plating and stiffeners). For cargo hold hatch covers of approved design which structurally have no access to the internals, close-up survey/thickness measurement shall be done of accessible parts of hatch covers structures. (See 7-A-6/Figure 4 Area D.)
- vi) All deck plating and underdeck structure inside line of hatch openings between cargo hold hatches. (See 7-A-6/Figure 4 Area E.)
- vii) All areas of inner bottom plating. (See 7-A-6/Figure 4 Area F.)

5.15.5 Thickness Measurement Requirements (1 July 2006)

Representative thickness measurement to determine both general and local levels of corrosion in the shell frames and their end attachments in all cargo holds and ballast tanks is to be carried out. Thickness measurement is also to be carried out to determine the corrosion levels on the transverse bulkhead plating.

Provided the Surveyor is satisfied by the close-up examination that there is no structural diminution and the hard protective coating, where applied, is found to be in GOOD condition, the extent of thickness measurements of structural members subject to close-up surveys may be specially considered.

Where substantial corrosion is found, additional thickness measurements in accordance with 7-3-2/7 are to be taken to confirm the extent of substantial corrosion. These extended thickness measurements are to be carried out before the survey is credited as completed.

Suspect areas identified at previous surveys are to be examined. Areas of substantial corrosion identified at previous surveys are to have thickness measurements taken.

The Surveyor may require further thickness measurements, as deemed necessary.

Transverse sections are to be chosen where the largest reductions are suspected to occur or are revealed from deck plating measurements.

Minimum requirements for thickness measurement at Special Periodical Survey are as follows:

5.15.5(a) Special Periodical Survey No. 1 (Age ≤ 5 years)

- i) Suspect areas.

5.15.5(b) Special Periodical Survey No. 2 (5 < Age ≤ 10 years)

- i) Suspect areas.
- ii) One (1) transverse section of deck plating in way of a cargo space hatch opening (i.e., outside of cargo hatch opening) within the amidships 0.5L.
- iii) Measurement for general assessment and recording of corrosion pattern of those structural members subject to Close-up Survey.

5.15.5(c) Special Periodical Survey No. 3 (10 < Age ≤ 15 years)

- i) Suspect areas.
- ii) Within the cargo length area, each deck plate outside line of cargo hatch openings.
- iii) Two (2) transverse sections within the amidships 0.5L in way of two (2) different cargo spaces.
- iv) All wind and water strakes within the cargo length area.
- v) Selected wind and water strakes outside the cargo length area.
- vi) (1 July 2004) All cargo hold hatch covers and coamings (plating and stiffeners).
- vii) (1 July 2004) Internals in forepeak and afterpeak tanks, including plating and stiffeners of forepeak and afterpeak tank bulkheads.
- viii) Measurement for general assessment and recording of corrosion pattern of those structural members subject to Close-up Survey.

5.15.5(d) *Special Periodical Survey No. 4 and Subsequent Special Periodical Surveys (Age > 15 years)*

- i) Suspect areas.
- ii) (1 July 2004) Each deck plate outside line of cargo hatch openings within the cargo length area, all exposed main deck plates full length and all exposed first-tier superstructure deck plates (poop, bridge and forecastle decks).
- iii) (1 July 2004) A minimum of three transverse sections in way of cargo spaces within the amidships 0.5L.
- iv) All wind and water strakes full length port and starboard.
- v) (1 July 2004) All cargo hold hatch covers and coamings (plating and stiffeners).
- vi) (1 July 2004) Lowest strakes and strakes in way of tween decks of all transverse bulkheads in cargo space together with internals in way.
- vii) (1 July 2004) Internals in forepeak and afterpeak tanks, including plating and stiffeners of forepeak and afterpeak tank bulkheads.
- viii) Duct keel or pipe tunnel plating and internals.
- ix) (1 July 2004) Each bottom plate including lower turn of bilge within the cargo length area, all keel plates full length and also additional bottom plates in way of cofferdams, machinery space and aft end of tanks.
- x) (1 July 2004) Plating of seachests. Shell plating in way of overboard discharges as considered necessary by the attending Surveyor.
- xi) Measurement for general assessment and recording of corrosion pattern of those structural members subject to Close-up Survey.

5.15.6 Tank Testing Requirements (1 July 2006)

All boundaries of ballast tanks and deep tanks used for water ballast within the cargo length area are to be pressure-tested, in addition to and in accordance with 7-3-2/5.1.10. For fuel oil tanks, representative tanks are to be pressure tested.

5.15.7 Drydocking Requirements (1 July 2006)

In addition to the requirements of 7-3-2/5.1.2, the overall and close-up surveys and thickness measurements, as applicable, of the lower portions of the cargo holds and ballast tanks are to be carried out while the vessel is in drydock in accordance with the applicable requirements for Special Periodical Surveys, if not already carried out.

Note: Lower portions of the cargo holds and ballast tanks are considered to be the parts below light ballast waterline.

5.17 Vessels Carrying Vehicles (2012)

In addition to the applicable requirements of 7-3-2/1.17, the Special Periodical Survey – Hull is also to include the following for bow doors, inner doors, side shell doors and stern doors:

- Examination, tests and checks of sufficient extent to verify that the bow, inner, side shell and stern doors, are in satisfactory condition and considered able to remain in compliance with the applicable requirements, subject to proper maintenance and operation in accordance with the Operation and Maintenance Manual (OMM) or manufacturer's recommendations and the periodical surveys being carried out at the due dates for the five year period until the next Special Survey.
- The examinations of the doors are to be supplemented by thickness measurements and testing to verify compliance with applicable requirements so that the structural and weathertight integrity remain effective. The examination is to identify the presence of corrosion, significant deformation, fractures, damages or other structural deterioration.

- Clearances of hinges, bearings and thrust bearings are to be taken. Unless otherwise specified in the OMM or by manufacturer's recommendation, the measurement of clearances on Ro-Ro cargo ships may be limited to representative bearings where dismantling is needed in order to measure the clearances. If dismantling is carried out, a visual examination of hinge pins and bearings together with NDT of the hinge pin is to be carried out.
- A close visual inspection, supplemented by Nondestructive Testing and thickness measurement, is to be carried out of securing, supporting and locking devices, including welding, to the extent considered necessary by the attending surveyor. Where fractures are revealed, a thorough examination, supported by Nondestructive Testing, is to be carried out in the surrounding area and for similar items.
- The maximum diminution of hinging arms, securing, supporting and locking devices is not to be more than 15% of the as-built thickness. Certain designs may be subject to special consideration.
- Checking the effectiveness of sealing arrangements by hose testing or equivalent is to be carried out.
- Non-return valves are to be examined after dismantling

5.19 Bulk Carriers – Double Skin ESP and Bulk Carrier Features of Combination Carriers – Double Skin ESP (2005)

In addition to the applicable requirements of 7-3-2/5.1, the Special Periodical Survey is also to include the following:

5.19.1 Survey Planning (1 July 2006)

Survey planning meeting is to be held in accordance with 7-3-2/9.2.

Survey program is to be developed in accordance with 7-3-2/9.1.

5.19.2 General (1 July 2006)

The Special Periodical Survey is to include, in addition to the requirements of the Annual Survey, examination, tests and checks of sufficient extent to ensure that the hull and related piping, as required herein, are in a satisfactory condition and fit for the intended purpose for the new period of class of 5 years to be assigned, subject to proper maintenance and operation and to periodical surveys being carried out at the due dates.

5.19.3 Overall Survey Requirements (1 July 2006)

All cargo holds, ballast tanks, including double bottom and double side tanks, pipe tunnels, cofferdams and void spaces bounding cargo holds, decks and outer hull are to be examined. This examination is to be supplemented by thickness measurement and testing as required to ensure that the structural integrity remains effective. The aim of the examination is to discover substantial corrosion, significant deformation, fractures, damages or other structural deterioration that may be present.

All piping systems within the above spaces are to be examined and operationally tested to working pressure to the satisfaction of the Surveyor to ensure that tightness and condition remain satisfactory.

5.19.3(a) Hatch covers and coamings (1 July 2008). A thorough examination of the items listed in 7-3-2/1.19.1 is to be carried out, in addition to all hatch covers and coamings.

Checking of the satisfactory operation of all mechanically operated hatch covers is to be made, including:

- Stowage and securing in open condition
- Proper fit and efficiency of sealing in closed condition
- Operational testing of hydraulic and power components, wires, chains and link drives

Checking the effectiveness of sealing arrangements of all hatch covers by hose testing or equivalent is to be carried out.

5.19.3(b) Extent of Overall Survey. An overall survey of all tanks and spaces is to be carried out.

Fuel oil, lube oil and fresh water tanks in the cargo length area are to be examined in accordance with 7-3-2/5.1.7(d).

5.19.4 Close-up Survey Requirements (1 July 2008)

Close-up Survey of transverse bulkheads is to be carried out at the following levels:

- Immediately above the inner bottom and immediately above the line of gussets (if fitted) and shedders for ships without lower stools.
- Immediately above and below the lower stool shelf plate (for those ships fitted with lower stools) and immediately above the line of shedder plates.
- About mid-height of the bulkhead.
- Immediately below the upper deck plating and immediately adjacent to the upper wing tank, and immediately below the upper stool shelf plate for those ships fitted with upper stools, or immediately below the topside tank.

With reference to cargo and ballast history and coating arrangements, tanks and holds are to be selected for Close-up Survey which will provide the best representative sampling of areas likely to be most exposed to the effects of corrosion, swash and stress concentration.

For areas in spaces where hard protective coatings are found to be in GOOD condition, the extent of close-up surveys may be specially considered.

The survey extent of ballast tanks converted to void spaces is to be specially considered in relation to the requirements for ballast tanks. As a minimum, sufficient close-up inspection and thickness measurements are to be carried out to determine the actual average condition of the structure under coating.

For close-up surveys of ore carriers, refer to 7-A-16/Table 18 “Minimum Requirements for CLOSE-UP Examination at Special Periodical Surveys– Ore Carriers”.

The Surveyor may extend the close-up survey as deemed necessary, taking into account the maintenance of the spaces under survey, the condition of the corrosion prevention system and where spaces have structural arrangements or details which have suffered defects in similar spaces or on similar ships according to available information.

Minimum requirements for close-up survey at Special Periodical Survey are as follows.

5.19.4(a) Special Periodical Survey No. 1 (Age ≤ 5 years)

- i) One (1) transverse web frame⁽¹⁾ in two (2) representative ballast tanks of each type in topside, hopper side and double side ballast tanks. (This is to include the foremost topside and double side ballast tanks on either side) (See 7-A-15/Figure 1 Area A.)
- ii) Two (2) selected cargo hold transverse bulkheads⁽²⁾. (See 7-A-15/Figure 1 Area C.)
- iii) (1 July 2016) All cargo hold hatch covers and coamings (plating and stiffeners). For cargo hold hatch covers of approved design which structurally have no access to the internals, close-up survey/thickness measurement shall be done of accessible parts of hatch covers structures. (See 7-A-15/Figure 1 Area D.)

5.19.4(b) Special Periodical Survey No. 2 (5 < Age ≤ 10 years)

- i) One (1) transverse web frame⁽¹⁾ in all ballast tanks. (See 7-A-15/Figure 1 Area A.)
- ii) Forward and aft transverse bulkheads, including stiffening systems in a transverse section including topside, hopper side and double side ballast tanks on one side of the ship (i.e., port or starboard). (See 7-A-15/Figure 1 Area A.)
- iii) (1 July 2016) 25% of ordinary transverse frames for transverse framing system or 25% of longitudinals for longitudinal framing system on side shell and inner side plating at forward, middle and aft parts, in the foremost double side ballast tanks (See 7-A-15/Figure 2 Area B.)
- iv) One (1) transverse bulkhead⁽²⁾ in all cargo holds. (See 7-A-15/Figure 1 Area C.)

v) (1 July 2016) All cargo hold hatch covers and coamings (plating and stiffeners). For cargo hold hatch covers of approved design which structurally have no access to the internals, close-up survey/thickness measurement shall be done of accessible parts of hatch covers structures. (See 7-A-15/Figure 1 Area D.)

vi) All deck plating and under deck structure inside line of hatch openings between all cargo hold hatches. (See 7-A-15/Figure 1 Area E.)

5.19.4(c) Special Periodical Survey No. 3 ($10 < \text{Age} \leq 15$ years)

i) All transverse web frames⁽¹⁾ in all ballast tanks. (See 7-A-15/Figure 1 Area A.)

ii) All transverse bulkheads, including stiffening systems in all ballast tanks. (See 7-A-15/Figure 1 Area A.)

iii) (1 July 2016) 25% of ordinary transverse frames for transverse framing system or 25% of longitudinals for longitudinal framing system on side shell and inner side plating at forward, middle and aft parts, in all double side ballast tanks (See 7-A-15/Figure 2 Area B.)

iv) All cargo hold transverse bulkheads⁽²⁾. (See 7-A-15/Figure 1 Area C.)

v) (1 July 2016) All cargo hold hatch covers and coamings (plating and stiffeners). For cargo hold hatch covers of approved design which structurally have no access to the internals, close-up survey/thickness measurement shall be done of accessible parts of hatch covers structures. (See 7-A-15/Figure 1 Area D.)

vi) All deck plating and under deck structure inside line of hatch openings between all cargo hold hatches. (See 7-A-15/Figure 1 Area E.)

5.19.4(d) Special Periodical Survey No. 4 and Subsequent Special Periodical Surveys ($\text{Age} > 15$ years)

i) All transverse web frames⁽¹⁾ in all ballast tanks. (See 7-A-15/Figure 1 Area A.)

ii) All transverse bulkheads, including stiffening systems in all ballast tanks. (See 7-A-15/Figure 1 Area A.)

iii) (1 July 2016) All ordinary transverse frames for transverse framing system or all longitudinals for longitudinal framing system on side shell and inner side plating at forward, middle and aft parts, in all double side ballast tanks (See 7-A-15/Figure 2 Area B.)

iv) All cargo hold transverse bulkheads⁽²⁾. (See 7-A-15/Figure 1 Area C.)

v) (1 July 2016) All cargo hold hatch covers and coamings (plating and stiffeners). For cargo hold hatch covers of approved design which structurally have no access to the internals, close-up survey/thickness measurement shall be done of accessible parts of hatch covers structures. (See 7-A-15/Figure 1 Area D.)

vi) All deck plating and under deck structure inside line of hatch openings between all cargo hold hatches. (See 7-A-15/Figure 1 Area E.)

Notes:

1 Transverse web frame includes associated plating, stiffeners and longitudinals.
In fore and aft peak tanks, transverse web frame means a complete transverse web frame ring, including adjacent structural members.

2 Cargo hold transverse bulkhead includes plating, stiffeners and girders, and internal structure of upper and lower stools, where fitted.

5.19.5 Thickness Measurement Requirements (1 July 2013)

Where substantial corrosion is found, additional thickness measurements in accordance with 7-3-2/7 are to be taken to confirm the extent of substantial corrosion. These extended thickness measurements are to be carried out before the survey is credited as completed.

Suspect areas identified at previous surveys are to be examined. Areas of substantial corrosion identified at previous surveys are to have thickness measurements taken.

For vessels built under IACS Common Structural Rules, the identified substantial corrosion areas may be:

- i) Protected by coating applied in accordance with the coating manufacturer's requirements and examined at annual intervals to confirm the coating in way is still in GOOD condition, or alternatively
- ii) Required to be measured at annual intervals.

The Surveyor may require further thickness measurements, as deemed necessary.

Where hard protective coatings are found to be in GOOD condition, the extent of thickness measurements of structural members subject to close-up surveys may be specially considered.

Transverse sections are to be chosen where the largest reductions are suspected to occur or are revealed from deck plating measurements, one of which is to be in the amidships area.

Representative thickness measurement to determine both general and local levels of corrosion in the transverse web frames in all ballast tanks is to be carried out.

Thickness measurement is also to be carried out to determine the corrosion levels on the transverse bulkhead plating.

Minimum requirements for thickness measurement at Special Periodical Survey are as follows:

5.19.5(a) Special Periodical Survey No. 1 (Age ≤ 5 years)

- i) Suspect areas throughout the vessel.
- ii) Measurement, for general assessment and recording of corrosion patterns, of structural members subject to close-up survey.

5.19.5(b) Special Periodical Survey No. 2 (5 < Age ≤ 10 years)

- i) Suspect areas throughout the vessel.
- ii) Two (2) transverse sections of deck plating outside the line of cargo hatch openings within the cargo length area.
- iii) Plates in wind-and-water strakes in way of the two (2) transverse sections considered above.
- iv) (1 July 2008) Selected wind-and-water strake plating, outside the cargo length area.
- v) Measurement, for general assessment and recording of corrosion patterns, of structural members subject to Close-up Survey.

5.19.5(c) Special Periodical Survey No. 3 (10 < Age ≤ 15 years)

- i) Suspect areas throughout the vessel.
- ii) Each deck plate outside line of cargo hatch openings within the cargo length area
- iii) Two (2) transverse sections, one (1) in the amidships area, outside the line of cargo hatch openings within the cargo length area.
- iv) All plating in two (2) wind-and-water strakes, port and starboard, within the cargo length area.
- v) Selected wind-and-water strake plating, outside the cargo length area.
- vi) All cargo hold hatch covers and coamings (plating and stiffeners).
- vii) Internals in forepeak and afterpeak tanks including plating and stiffeners of bulkheads.
- viii) Measurement, for general assessment and recording of corrosion pattern, of structural members subject to Close-up Survey.

5.19.5(d) Special Periodical Survey No. 4 and Subsequent Special Periodical Surveys (Age > 15 years)

- i)* Suspect areas throughout the vessel.
- ii)* All exposed main deck plates full length and all exposed first-tier superstructure deck plates (poop, bridge and forecastle decks).
- iii)* Three (3) transverse sections, one (1) in the amidships area, outside the line of cargo hatch openings within the cargo length area.
- iv)* All plating in two (2) wind-and-water strakes, port and starboard, full length.
- v)* All cargo hold hatch covers and coamings (plating and stiffeners).
- vi)* Internals in forepeak and afterpeak tanks, including plating and stiffeners of forepeak and afterpeak tank bulkheads.
- vii)* Duct keel or pipe tunnel plating and internals.
- viii)* Each bottom plate, including lower turn of bilge within the cargo length area, all keel plates full length and also additional bottom plates in way of cofferdams, machinery space and aft end of tanks.
- ix)* Plating of sea chests. Shell plating in way of overboard discharges as considered necessary by the attending Surveyor.
- x)* Measurement, for general assessment and recording of corrosion patterns of structural members subject to Close-up Survey.

5.19.6 Tank Testing Requirements

Boundaries of ballast tanks, deep tanks and cargo holds used for ballast within the cargo length area are to be tested in addition to and in accordance with 7-3-2/5.1.10.

5.19.7 Drydocking Requirements (1 July 2006)

In addition to the requirements of 7-3-2/5.1.2, the overall and close-up surveys and thickness measurements, as applicable, of the lower portions of the cargo holds and ballast tanks are to be carried out while the vessel is in drydock in accordance with the applicable requirements for Special Periodical Survey, if not already carried out.

Note: Lower portions of the cargo holds and ballast tanks are considered to be the parts below light ballast waterline.

5.19.8 Bulk Carriers Subject to SOLAS XII/12 and XII/13 (2007)

5.19.8(a) Vessels complying with SOLAS XII/12. Water ingress detection and alarm systems for cargo holds, ballast and dry spaces are to be examined and tested.

5.19.8(b) Vessels complying with SOLAS XII/13. Means for draining and pumping of tanks forward of the collision bulkhead and bilges of dry spaces any part of which extends forward of the foremost cargo hold, and their controls are to be examined and tested.

5.21 Chemical Carriers ESP (1 July 2006)

In addition to the applicable requirements of 7-3-2/5.1, the Special Periodical Survey is also to include the following:

5.21.1 Survey Planning

Survey planning meeting is to be held in accordance with 7-3-2/9.2.

Survey program is to be developed in accordance with 7-3-2/9.1.

5.21.2 General

The Special Periodical Survey is to include, in addition to the requirements of the Annual Survey, examination, tests and checks of sufficient extent to ensure that the hull and related piping, as required herein, are in a satisfactory condition and fit for the intended purpose for the new period of class of 5 years to be assigned, subject to proper maintenance and operation and to periodical surveys being carried out at the due dates.

Insulation is to be removed in way of any distorted or otherwise suspect insulation or structural part of the cargo tanks or elsewhere to carry out any of the examinations as required by the Surveyor.

5.21.3 Overall Survey Requirements

All cargo tanks, ballast tanks including double bottom tanks, pump rooms, pipe tunnels, cofferdams and void spaces bounding cargo tanks, decks and outer hull are to be examined. This examination is to be supplemented by thickness measurement and testing as required, to ensure that the structural integrity remains effective. The aim of the examination is to discover substantial corrosion, significant deformation, fractures, damages or other structural deterioration, that may be present.

Cargo piping on deck and all piping systems within the above tanks and spaces are to be examined and operationally tested to working pressure to attending Surveyor's satisfaction to ensure that tightness and condition remain satisfactory. Special attention is to be given to ballast piping in cargo tanks and any cargo piping in ballast tanks and void spaces. Surveyors are to be advised on all occasions when this piping, including valves and fittings, is open during repair periods and can be examined internally.

Venting systems of cargo tanks, including secondary means of protection, are to be examined. All pressure/vacuum valves including flame arresting and drainage arrangements, are to be opened, cleaned, examined, tested and set in accordance with manufacturer's specifications, as applicable.

5.21.3(a) Conditions of Coating. Where provided, the condition of the corrosion prevention system of cargo tanks is to be examined.

5.21.3(b) Ballast Tanks (1 July 2008). A ballast tank is to be examined at subsequent annual intervals where:

- i) A hard protective coating has not been applied from the time of construction, or
- ii) A soft or semi-hard coating has been applied, or
- iii) Substantial corrosion is found within the tank, or
- iv) The hard protective coating is found to be in less than GOOD condition and the hard protective coating is not repaired to the satisfaction of the Surveyor.

Thickness measurements are to be carried out as deemed necessary by the Surveyor.

5.21.3(c) Extent of Overall Survey. An overall survey of all tanks and spaces is to be carried out.

The survey of stainless steel tanks may be carried out as an Overall Survey supplemented by Close-up Survey as deemed necessary by the Surveyor.

5.21.4 Close-up Survey Requirements (1 July 2013)

5.21.4(a) General

The Surveyor may extend the Close-up Survey as deemed necessary, taking into account the maintenance of the tanks under survey, the condition of the corrosion prevention system, with particular attention being given to the following situations:

- Tanks having structural arrangements or details which have suffered defects in similar tanks or on similar ships according to available information.
- In tanks which have structures approved with reduced scantlings due to an approved corrosion control system.

With reference to cargo and ballast history and coating arrangements, tanks are to be selected for Close-up Survey which will provide the best representative sampling of areas likely to be most exposed to the effects of corrosion, swash and stress concentration.

Close-up Surveys are to include welded attachments and deck transverse when fitted on the deck.

For areas in tanks where hard protective coatings are found to be in GOOD condition, the extent of Close-up Surveys may be specially considered.

5.21.4(b) Minimum Requirements for Close-up Survey at Special Periodical Survey for Single Hull Vessels

For further structural details, see 7-A-7/Figures 6-9.

i) Special Periodical Survey No. 1 (Age ≤ 5 years)

- One (1) complete transverse web frame ring including adjacent structural members in a ballast wing tank. (See 7-A-7/Figure 9 Area A)
- One (1) deck transverse including adjacent structural members in a cargo tank or on deck. (See 7-A-7/Figure 9 Area B)
- Lower part of one (1) transverse bulkhead for single hull, including girder system and adjacent structural members in:
 - One (1) ballast tank
 - One (1) cargo wing tank
 - One (1) cargo center tank⁽²⁾

(See 7-A-7/Figure 9 Area D)

ii) Special Periodical Survey No. 2 (5 < Age ≤ 10 years)

- All plating and internal structure including all tank boundaries and internal structure and external structure on deck in way of all web frame rings in a ballast wing tank or double bottom ballast tank⁽¹⁾. (See 7-A-7/Figure 9 Area A)
- One (1) deck transverse including adjacent deck structural members in:
 - Each remaining ballast tank or on deck
 - One (1) cargo wing tank or on deck
 - Two (2) cargo center tanks or on deck

(See 7-A-7/Figure 9 Area B)

- Both transverse bulkheads including girder system and adjacent structural members in a ballast wing tank. (See 7-A-7/Figure 9 Area C)
- Lower part of one (1) transverse bulkhead including girder system and adjacent structural members in:
 - Each remaining ballast tank
 - One (1) cargo wing tank
 - Two (2) cargo center tanks⁽²⁾

(See 7-A-7/Figure 9 Area D)

- iii) *Special Periodical Survey No. 3 (10 < Age ≤ 15 years)*
- All plating and internal structure including all tank boundaries and internal structure and external structure on deck in way of all web frame rings in all ballast tanks. (See 7-A-7/Figure 9 Area C, E)
 - All plating and internal structure including all tank boundaries and internal structure and external structure on deck in way of all web frame rings in a cargo wing tank. (See 7-A-7/Figure 9 Area E)
 - One (1) complete transverse web frame ring including adjacent structural members in each remaining cargo tank. (See 7-A-7/Figure 9 Area A)
 - All transverse bulkheads including girder system and adjacent structural members in all cargo tanks. (See 7-A-7/Figure 9 Area C)
 - All transverse bulkheads including girder system and adjacent structural members in all ballast tanks. (See 7-A-7/Figure 9 Area C)
- iv) *Special Periodical Survey No. 4 and Subsequent Special Periodical Surveys (Age > 15 years)*
- All plating and internal structure including all tank boundaries and internal structure and external structure on deck in way of all web frame rings in all ballast tanks. (See 7-A-7/Figure 9 Area C, E)
 - All plating and internal structure including all tank boundaries and internal structure and external structure on deck in way of all web frame rings in a cargo wing tank. (See 7-A-7/Figure 9 Area E)
 - One (1) complete transverse web frame ring including adjacent structural members in each remaining cargo tank. (See 7-A-7/Figure 9 Area A)
 - All transverse bulkheads including girder system and adjacent structural members in all cargo tanks. (See 7-A-7/Figure 9 Area C)
 - All transverse bulkheads including girder system and adjacent structural members in all ballast tanks. (See 7-A-7/Figure 9 Area C)
 - Any additional tanks and structure as considered necessary by the Surveyor.

5.21.4(c) *Minimum Requirements for Close-up Survey at Special Periodical Survey for Double Hull Vessels*

For further structural details, see 7-A-7/Figures 10-12.

- i) *Special Periodical Survey No. 1 (Age ≤ 5 years)*
- One (1) complete transverse web frame ring including adjacent structural members in a ballast double hull tank^(1, 3). (See 7-A-7/Figure 10 Area 1)
 - One (1) deck transverse including adjacent deck structural members (or external structure on deck in way of the tank, where applicable) in a cargo tank or on deck. (See 7-A-7/Figure 10 Area 2)
 - One (1) complete transverse bulkhead, including girder system and adjacent structural members, such as longitudinal bulkheads, girders in double bottom tanks, inner bottom plating, hopper side and connecting brackets in a ballast tank.⁽¹⁾ (See 7-A-7/Figure 11 Area 4)
 - Lower part of one (1) transverse bulkhead, including girder system, adjacent structural members (such as longitudinal bulkheads) and internal structure of lower stool, where fitted, in:
 - One (1) cargo wing tank
 - One (1) cargo center tank⁽²⁾(See 7-A-7/Figure 11 Area 5)

- ii) *Special Periodical Survey No. 2 ($5 < \text{Age} \leq 10$ years)*
- All transverse web frame rings including adjacent structural members in a ballast wing tank or ballast double hull tank^(1,3). (See 7-A-7/Figure 10 Area 1)
 - The knuckle area and the upper part (3 meters approx.) of one web frame, including adjacent structural members, in each remaining ballast tank⁽⁴⁾. (See 7-A-7/Figure 12 Area 6)
 - One (1) deck transverse including adjacent deck structural members (or external structure on deck in way of the tank, where applicable) in two cargo tanks. (See 7-A-7/Figure 10 Area 2)
 - One (1) complete transverse bulkhead, including girder system and adjacent structural members, such as longitudinal bulkheads, girders in double bottom tanks, inner bottom plating, hopper side and connecting brackets in each ballast tank⁽¹⁾. (See 7-A-7/Figure 11 Area 4)
 - Lower part of one (1) transverse bulkhead, including girder system, adjacent structural members (such as longitudinal bulkheads) and internal structure of lower stool, where fitted, in:
 - One (1) cargo wing tank
 - Two (2) cargo center tanks⁽²⁾(See 7-A-7/Figure 11 Area 5)
- iii) *Special Periodical Survey No. 3 ($10 < \text{Age} \leq 15$ years)*
- All transverse web frame rings including adjacent structural members in all ballast tanks⁽³⁾. (See 7-A-7/Figure 10 Area 1)
 - All transverse web frame rings, including deck transverse, longitudinal bulkhead vertical girder and cross ties, where fitted, and adjacent structural members, in a cargo wing tank. (See 7-A-7/Figure 12 Area 7)
 - One (1) transverse web frame ring, including deck transverse, longitudinal bulkhead vertical girder and cross ties, where fitted, and adjacent structural members, in each remaining cargo tank. (See 7-A-7/Figure 12 Area 7)
 - All complete transverse bulkheads, including girder system, adjacent structural members (such as longitudinal bulkheads) and internal structure of lower and upper stools, where fitted, in all cargo tanks. (See 7-A-7/Figure 11 Area 3)
 - All complete transverse bulkheads, including girder system and adjacent structural members, such as longitudinal bulkheads, girders in double bottom tanks, inner bottom plating, hopper side and connecting brackets in all ballast tanks. (See 7-A-7/Figure 11 Area 4)
- iv) *Special Periodical Survey No. 4 and Subsequent Special Periodical Surveys ($\text{Age} > 15$ years)*
- All transverse web frame rings including adjacent structural members in all ballast tanks⁽³⁾. (See 7-A-7/Figure 10 Area 1)
 - All transverse web frame rings, including deck transverse, longitudinal bulkhead vertical girder and cross ties, where fitted, and adjacent structural members, in a cargo wing tank. (See 7-A-7/Figure 12 Area 7)
 - One (1) transverse web frame ring, including deck transverse, longitudinal bulkhead vertical girder and cross ties, where fitted, and adjacent structural members, in each remaining cargo tank. (See 7-A-7/Figure 12 Area 7)
 - All complete transverse bulkheads, including girder system, adjacent structural members (such as longitudinal bulkheads) and internal structure of lower and upper stools, where fitted, in all cargo tanks. (See 7-A-7/Figure 11 Area 3)

- All complete transverse bulkheads, including girder system and adjacent structural members, such as longitudinal bulkheads, girders in double bottom tanks, inner bottom plating, hopper side and connecting brackets in all ballast tanks. (See 7-A-7/Figure 11 Area 4)
- Any additional tanks and structure as deemed necessary by the Surveyor.

Notes:

- 1 Ballast double hull tank: means double bottom tank plus double side tank plus double deck tank, as applicable, even if these tanks are separate.
- 2 Where no center tanks are fitted (as in the case of center longitudinal bulkhead), transverse bulkheads in wing tanks are to be surveyed.
- 3 Web frame in a ballast tank means vertical web in side tank, hopper web in hopper tank, floor in double bottom tank and deck transverse in double deck tank (where fitted). In fore and aft peak tanks web frame means a complete transverse web frame ring including adjacent structural members.
- 4 Knuckle area is the area of the web frame around the connections of the slope hopper plating to the inner hull bulkhead and the inner bottom plating, up to 2 meters from the corners both on the bulkhead and the double bottom.

5.21.5 Thickness Measurement Requirements

The extent of thickness measurements of stainless steel hull structure may be specially considered, except for clad steel plating.

Where substantial corrosion is found, additional thickness measurements in accordance with 7-3-2/7 are to be taken to confirm the extent of substantial corrosion. These extended thickness measurements are to be carried out before the survey is credited as completed.

Suspect areas identified at previous surveys are to be examined. Areas of substantial corrosion identified at previous surveys are to have thickness measurements taken.

The Surveyor may require further thickness measurements, as deemed necessary.

Where hard protective coatings are found to be in GOOD condition, the extent of thickness measurements of structural members subject to Close-up Surveys may be specially considered.

Transverse sections are to be chosen where the largest reductions are suspected to occur or are revealed from deck plating measurements.

Minimum requirements for Thickness Measurement at Special Periodical Survey are as follows:

5.21.5(a) Special Periodical Survey No. 1 (Age ≤ 5 years)

- i) Suspect areas throughout the vessel.
- ii) One (1) transverse section of deck plating for the full beam of the ship within the cargo area, in way of a ballast tank, if any.
- iii) Measurements, for general assessment and recording of corrosion patterns, of those structural members subject to Close-up Survey.

5.21.5(b) Special Periodical Survey No. 2 (5 < Age ≤ 10 years)

- i) Suspect areas throughout the vessel.
- ii) All main deck plating within the cargo area.
- iii) One (1) transverse section within the cargo area.
- iv) Selected wind-and-water strakes outside the cargo area.
- v) Internals in forepeak and afterpeak tanks including plating and stiffeners of bulkheads.
- vi) Measurements, for general assessment and recording of corrosion patterns, of those structural members subject to Close-up Survey.

5.21.5(c) *Special Periodical Survey No. 3 (10 < Age ≤ 15 years)*

- i) Suspect areas throughout the vessel.
- ii) All main deck plating within the cargo area.
- iii) Two (2) transverse sections within the cargo area, including at least one (1) section in way of a ballast tank within amidships 0.5L.
- iv) All wind-and-water strakes within the cargo area, and selected wind-and-water strakes outside the cargo area.
- v) Internals in forepeak and afterpeak tanks including plating and stiffeners of bulkheads.
- vi) Measurements, for general assessment and recording of corrosion patterns, of those structural members subject to Close-up Survey.

5.21.5(d) *Special Periodical Survey No. 4 and Subsequent Special Periodical Surveys (Age > 15 years)*

- i) Suspect areas throughout the vessel.
- ii) All main deck plating within the cargo area, all exposed main deck plating outside the cargo area and all exposed first tier superstructure deck plating (poop, bridge and forecastle decks).
- iii) A minimum of three (3) transverse sections within the cargo area, including at least one (1) section in way of a ballast tank within amidships 0.5L.
- iv) All wind-and-water strakes, full length.
- v) Internals in forepeak and afterpeak tanks including plating and stiffeners of bulkheads.
- vi) Duct keel or pipe tunnel plating and internals.
- vii) All keel plates full length. All bottom plates within the cargo area, also additional bottom plates in way of cofferdams, machinery space and aft end of tanks.
- viii) Plating of seachests. Shell plating in way of overboard discharges as considered necessary by the attending Surveyor.
- ix) Measurements, for general assessment and recording of corrosion patterns, of those structural members subject to Close-up Survey.

5.21.6 Extent of Tank Testing (1 July 2014)

In addition to 7-3-2/5.1.10, tank testing requirements at Special Periodical Survey are as follows:

5.21.6(a) *Special Periodical Survey No. 1 (Age ≤ 5 years)*

- i) All ballast tank boundaries.
- ii) Cargo tank boundaries facing ballast tanks, void spaces, pipe tunnels, fuel oil tanks, pump rooms or cofferdams.

5.21.6(b) *Special Periodical Survey No. 2 and Subsequent Special Periodical Surveys (Age > 5 years)*

- i) All ballast tank boundaries.
- ii) (1 July 2007) All cargo tank bulkheads.

Note: All minimum requirements for cargo tank testing at Special Survey are given in 7-3-2/5.21.6(a) and 7-3-2/5.21.6(b) above. Cargo tank testing carried out by the vessel's crew under the direction of the Master may be accepted by the Surveyor provided the following conditions are complied with:

- i) (1 July 2016) A tank testing procedure, specifying fill heights, for tanks and bulkheads being tested, has been submitted by the owner and reviewed by the Surveyor prior to the testing being carried out;
- ii) There is no record of leakage, distortion or substantial corrosion that would affect the structural integrity of the tank;

- iii) The tank testing has been satisfactorily carried out within special survey window not more than 3 months prior to the date of the survey on which the overall or close up survey is completed;
- iv) The satisfactory results of the testing is recorded in the vessel's logbook;
- v) The internal and external condition of the tanks and associated structure are found satisfactory by the Surveyor at the time of the overall and close up survey.

5.21.7 Cargo and Ballast Piping

For vessels over 10 years of age, selected steel cargo pipes outside cargo tanks and ballast pipes passing through cargo tanks are to be:

- Thickness measured at random or selected pipe lengths to be opened for internal examination.
- Pressure tested to the maximum working pressure.

Special attention is to be given to cargo/slop discharge piping through ballast tanks and void spaces.

5.21.8 Drydocking Requirements

In addition to the requirements of 7-3-2/5.1.2, the overall and close-up surveys and thickness measurements, as applicable, of the lower portions of the cargo tanks and ballast tanks are to be carried out while the vessel is in drydock in accordance with the applicable requirements for Special Periodical Survey, if not already carried out.

Note: Lower portions of the cargo and ballast tanks are considered to be the parts below light ballast waterline.

5.23 Compressed Natural Gas Carriers (2017)

In addition to the requirements at annual survey, at each Special Periodical Survey, in addition to a general review of the maintenance records and where applicable and required for classification of the CNG carrier, the Surveyor is to verify the effectiveness of the following items by visual examination and operational testing, as appropriate:

- i) Gas detectors are to be calibrated or verified with sample gases.
- ii) The emergency shutdown system is to be tested.

5.23.1 Containment Systems

Survey of the containment system is to be carried out in accordance with the survey inspection plan and in line with the applicable requirements of the following.

5.23.1(a) Special Periodical Surveys

- i) *Cargo Tanks (Primary Containers).* An external examination is to be made of all cargo tanks, after being gas freed, including internal mountings and equipment.
- ii) *Cargo Tank Supports, Insulation and Hull Structures.* For independent tanks, foundations, chocks, sway braces, keys, anti-flotation arrangements, and the hull plating are to be examined, with special attention being given to the cargo tanks and insulation in way of the above. Framing adjacent to the cargo containment system is also to be examined.
- iii) *Cargo Tank Venting System.* Relief valves and venting systems for the primary cargo containment system are to be examined. All relief valves are to be opened, inspected, tested and readjusted as necessary. If the cargo tanks are equipped with relief valves with non-metallic membranes in the main or pilot valves, such non-metallic membranes are to be replaced. Where a proper record of continuous overhaul and retesting of individually identifiable relief valves is maintained, consideration will be given to acceptance on the basis of opening, internal examination and testing of a representative sampling of valves including each size of each type of gas or vapor relief valve in use, provided there is logbook evidence that the remaining valves have been overhauled and tested since the crediting of the previous Special Periodical Survey. The testing and setting of relief valves may be carried out in place or after removal.

- iv) *Cargo Handling and Piping Material.* All piping, machinery and equipment for loading, unloading, venting, compressing, refrigerating, heating or otherwise handling the gas or vapor and liquid nitrogen is to be examined, including removal of insulation and opening for examination, as deemed necessary. Where deemed suspect, a hydrostatic test to 1.25 times the Maximum Allowable Relief Valve Setting (MARVS) for the pipeline is to be carried out. After reassembly, the complete piping is to be tested for leaks. Where water cannot be tolerated and the piping cannot be dried prior to putting the system into service, the Surveyor may accept alternative testing fluids or alternative means of testing. All emergency shutdown valves and remote operating valves in the cargo piping systems are to be inspected and proven operable. The pressure relief valves are to be function-tested. A random selection of valves is to be opened for examination and adjusted.
- v) *Insulation Removals.* Insulation is to be removed in way of any suspect structural part of the cargo tanks.
- vi) *Thickness Measurements.* Where there is evidence of corrosion, or where one side of the cargo tank is exposed to a possible corrosive atmosphere, the plating of the cargo tanks is to be gauged by nondestructive means to determine the thickness.
- vii) *Nondestructive Testing.* Nondestructive testing is to supplement cargo tank inspection with special attention to be given to the integrity of the main structural members, tank shell and highly stressed areas, including welded connections as deemed necessary by the Surveyor. The following items are, inter alia, considered as highly stressed areas:
- Cargo tank supports and anti-rolling/anti pitching devices
 - Pipe connections
- viii) *Tank Testing in accordance with the Approved Plan.* Where nondestructive testing, or other evidence, such as leakage, raises doubts as to the structural integrity of a cargo tank, a hydrostatic or hydropneumatic pressure test is to be carried out. For independent tanks Type C and pressurized tanks B with MARVS 2.06 bar (2.1 kgf/cm², 30 psi) and over, the test pressure is to be 1.25 times MARVS.
- ix) *Electrical Bonding.* Electrical bonding arrangements, including bonding straps where fitted, of the piping systems located within cargo tanks, ballast tanks, pipe tunnels, cofferdams and void spaces bounding cargo tanks are to be examined.
- x) *Drainage Arrangements.* Systems for removing water from interbarrier spaces and holds are to be examined and tested as deemed necessary.
- xi) *Gas-tight Bulkhead.* All gas-tight bulkheads are to be examined. The effectiveness of gas-tight shaft sealing is to be verified.
- xii) *Miscellaneous.* The hoses and spool pieces used for segregation of piping systems for cargo, inert gas and bilge are to be examined.

5.23.1(b) *Special Periodical Survey No. 3 and Subsequent Special Periodical Surveys*

In addition to all of the requirements of Special Periodical Survey No. 1 or 2, the following requirements are to be complied with for Special Periodical Survey No. 3 and all subsequent Special Periodical Surveys.

- *Cargo Tanks (Primary Containers).* The plating of at least one (1) cargo tank, including pressure vessels, is to be gauged by nondestructive means to determine the thickness. Where only cargoes of a non-corrosive nature are carried, modifications to the extent of thickness measurements may be specially considered.

7 Extent of Thickness Measurement Requirements for those Areas of Substantial Corrosion within the Cargo Area

7.1 All Non ESP Vessels and General Dry Cargo Vessels (ESDC) (2004)

7.1.1 Plating

Suspect areas and adjacent plates.

- Five (5) point pattern over one (1) square meter.

7.1.2 Stiffeners

Suspect areas.

- Three (3) measurements each in line across web and flange.

7.3 Bulk Carriers – Non Double Skin ESP and Bulk Carrier Features of Combination Carriers – Non Double Skin ESP

7.3.1 Double Bottom and Hopper Structure

7.3.1(a) Inner/Double Bottom Plating

Suspect plates plus all adjacent plates.

- Five (5) point pattern for each panel between longitudinals over one (1) square meter of plating.

7.3.1(b) Inner/Double Bottom Longitudinals

Three (3) longitudinals where plates measured.

- Three (3) measurements in line across web and three (3) measurements on flange.

7.3.1(c) Longitudinal Girder or Transverse Floors

Suspect plates.

- Five (5) point pattern over about one (1) square meter.

7.3.1(d) Watertight Bulkhead (WT Floors)

Lower $\frac{1}{3}$ of tank.

- Five (5) point pattern over one (1) square meter of plating.

Upper $\frac{2}{3}$ of tank.

- Five (5) point pattern alternate plates over one (1) square meter of plating.

7.3.1(e) Web Frames

Suspect plating.

- Five (5) point pattern over one (1) square meter of plating.

7.3.2 Deck Structure including Cross Strips, Main Cargo Hatchways, Hatch Covers, Coamings and Topside Tanks

7.3.2(a) Cross Deck Strip Plating

Suspect cross deck plating.

- Five (5) point pattern between underdeck stiffeners over one (1) meter length.

7.3.2(b) *Underdeck Stiffeners*

Transverse members.

- Five (5) point pattern at each end and mid span.

Longitudinal member.

- Five (5) point pattern on both web and flange.

7.3.2(c) *Hatch Covers*

Skirt, each side and ends, three (3) locations.

- Five (5) point pattern each location.

Three (3) longitudinal bands, outboard strakes two (2) and centerline strake one (1).

- Five (5) point measurement each band

7.3.2(d) *Hatch Coamings*

Each side and end of coaming, one (1) band lower $\frac{1}{3}$, one (1) band upper $\frac{2}{3}$ of coaming.

- Five (5) point measurement each band. (i.e., end or side coaming)

7.3.2(e) *Topside Water Ballast Tanks*

i) *Watertight transverse bulkheads*

Lower $\frac{1}{3}$ of bulkhead.

- Five (5) point pattern over one (1) square meter of plating.

Upper $\frac{2}{3}$ of bulkhead.

- Five (5) point pattern over one (1) square meter of plating.

Stiffeners.

- Five (5) point pattern over one (1) meter length.

ii) *Two (2) representative swash transverse bulkheads*

Lower $\frac{1}{3}$ of bulkhead.

- Five (5) point pattern over one (1) square meter of plating.

Upper $\frac{2}{3}$ of bulkhead.

- Five (5) point pattern over one (1) square meter of plating.

Stiffeners.

- Five (5) point pattern over one (1) meter length.

iii) *Three (3) representative bays of sloping plating*

Lower $\frac{1}{3}$ of tank.

- Five (5) point pattern over one (1) square meter of plating.

Upper $\frac{2}{3}$ of tank

- Five (5) point pattern over one (1) square meter of plating.

Longitudinals, suspect and adjacent.

- Five (5) point pattern on both web and flange over one (1) meter length.

7.3.2(f) *Main Deck Plating*

Suspect plates, plus four (4) adjacent plates.

- Five (5) point pattern over one (1) square meter of plating.

7.3.2(g) *Main Deck Longitudinals*

Minimum of three (3) longitudinals where plating measured.

- Five (5) point pattern on both web and flange over one (1) meter length.

7.3.2(h) *Web Frames/Transverses*

Suspect plates.

- Five (5) point pattern over one (1) square meter.

7.3.3 **Shell Structure**

7.3.3(a) *Bottom and Side Shell Plating*

Suspect plate, plus four (4) adjacent plates.

- Five (5) point pattern for each panel between longitudinals.
- See other sections for particulars on gauging in way of tanks and cargo holds.

7.3.3(b) *Bottom/Side Shell Longitudinals*

Minimum of three (3) longitudinals in way of suspect areas.

- Three (3) measurements in line across web.
- Three (3) measurements across webs and one (1) measurement on flange.

7.3.4 **Transverse Bulkheads in Cargo Holds**

7.3.4(a) *Lower Stool*

Transverse band within 25 mm of welded connection to inner bottom.

- Five (5) points between stiffeners over one (1) meter length.

Transverse band within 15 mm of welded connection to shelf plate.

- Five (5) points between stiffeners over one (1) meter length.

7.3.4(b) *Transverse Bulkhead*

Transverse band approximately mid height.

- Five (5) point pattern over one (1) square meter of plating.

Transverse band at part of bulkhead adjacent to upper deck or below upper stool shelf plate, for those ships fitted with upper stool.

- Five (5) point pattern over one (1) square meter of plating.

7.3.5 **Cargo Holds**

7.3.5(a) *Side Shell Frames*

Suspect frames and each adjacent frame.

- At each end and mid span, five (5) point pattern of both web and flange.
- Five (5) point pattern within 25 mm of welded attachment to both shell and lower slope plate.

7.5 Tankers ESP (Oil Carriers and Oil Carrier Features of Combination Carriers – Non Double Hull and Chemical Carriers) (2010)

7.5.1 Bottom Structure for Oil Carriers ESP and Oil Carrier features of Combination Carriers ESP

7.5.1(a) Bottom Plating

Minimum of three (3) bays across tank, including aft bay. Measurement around and under all bell-mouths.

- Five (5) point pattern for each panel between longitudinals and webs.

7.5.1(b) Bottom Longitudinals

Minimum of three (3) longitudinals in each bay where bottom plating is measured.

- Three (3) measurements in line across the flange.
- Three (3) measurements on vertical web.

7.5.1(c) Bottom Transverse Webs

Three (3) webs in bays where bottom plating measured, with measurements at both ends and middle.

- Five (5) point pattern over two (2) square meter area.
- Single measurement on face flat.

7.5.1(d) Bottom Girders and Brackets

At fore and aft transverse bulkhead, bracket toes and in center of tank.

- Vertical line of single measurements on web plating with one (1) measurement between each panel stiffener or a minimum of three (3) measurements.
- Two (2) measurements across face flat.
- Five (5) point pattern on girder/bulkhead brackets.

7.5.1(e) Panel Stiffening

Where provided:

- Single measurements.

7.5.2 Deck Structure

7.5.2(a) Deck Plating

Two (2) bands across the tank.

- Minimum of three (3) measurements per plate per band.

7.5.2(b) Deck Longitudinals

Minimum of three (3) longitudinals each in two (2) bays.

- Three (3) measurements in line vertically on webs.
- Two (2) measurements on flange, if fitted.

7.5.2(c) Deck Girders and Brackets

At fore and aft transverse bulkhead bracket toes and in center of tanks.

- Vertical line of single measurements on web plating with one (1) measurement between each panel stiffener, or a minimum of three (3) measurements.
- Two (2) measurements across face flat.
- Five (5) point pattern on girder/bulkhead brackets.

7.5.2(d) *Deck Transverse Web*

Minimum of two (2) webs with measurements at middle and both ends of span.

- Five (5) point pattern over two (2) square meter areas.
- Single measurement on face flat.

7.5.2(e) *Panel Stiffening*

Where provided:

- Single measurements.

7.5.2(f) *Substantial Corrosion of more than 20%, in Chemical Carriers ESP.* In tanks in Chemical Carriers, where substantial corrosion covers more than 20% of the deck surface, the whole deck structure including longitudinals and web frames above the tank is to be thickness measured in accordance with the above.

7.5.3 Shell and Longitudinal Bulkheads

7.5.3(a) *Deckhead and Bottom Strakes and Strakes in way of Stringer Platforms*

Plating between each pair of longitudinals in a minimum of three (3) bays.

- Single measurements.

7.5.3(b) *All Other Strakes*

Plating between every third pair of longitudinals in same three (3) bays.

- Single measurements.

7.5.3(c) *Longitudinals – Deckhead and Bottom Strakes*

Each longitudinal in same three (3) bays.

- Three (3) measurements across web and one (1) measurement on flange.

7.5.3(d) *Longitudinals – All others*

Every third longitudinal in same three (3) bays.

- Three (3) measurements across web and one (1) measurement on flange.

7.5.3(e) *Longitudinal – Bracket*

Minimum of three (3) at top, middle and bottom of tank in same three (3) bays.

- Five (5) point pattern over area of bracket.

7.5.3(f) *Web Frames and Cross Ties*

Three (3) webs with minimum of three (3) locations on each web, including in way of cross tie connections.

- Five (5) point pattern over about two (2) square meter area.
- Single measurements on web frame and cross tie face flats.

7.5.4 Transverse Bulkheads and Swash Bulkheads

7.5.4(a) *Deckhead and Bottom Stakes, and Strakes in way of Stringer Platforms*

Plating between pair of stiffeners at three (3) locations – approximately $\frac{1}{4}$, $\frac{1}{2}$ and $\frac{3}{4}$ width of tank.

- Five (5) point pattern between stiffeners over one (1) meter length.

7.5.4(b) *All Other Strakes*

Plating between pair of stiffeners at middle location.

- Single measurement.

7.5.4(c) *Strakes in Corrugated Bulkheads*

Plating for each change of scantlings at center of panel and at flange or fabricated connection.

- Five (5) point pattern over about one (1) square meter of plating.

7.5.4(d) *Stiffeners*

Minimum of three (3) typical stiffeners.

- For web, five (5) point pattern over span between bracket connections (two (2) measurements across web at each bracket connection, and one (1) at center of span).
- For flanges, single measurements at each bracket toe and at center of span.

7.5.4(e) *Brackets*

Minimum of three (3) at top, middle and bottom of tank.

- Five (5) point pattern over area of bracket.

7.5.4(f) *Deep Webs and Girders*

Measurement at toe of bracket and at center of span.

- For web, five (5) point pattern over about one (1) square meter.
- Three (3) measurements across face flat.

7.5.4(g) *Stringer Platforms*

All stringers with measurements at both ends and middle.

- Five (5) point pattern over one (1) square meter of area.
- Single measurement near bracket toes and on face flats.

7.7 Tankers ESP (Oil Carriers and Oil Carrier Features of Combination Carriers – Double Hull and Chemical Carriers) (2010)

7.7.1 Bottom, Inner Bottom And Hopper Structure

7.7.1(a) *Bottom, inner bottom and hopper structure plating*

Minimum of three (3) bays across double bottom tank, including aft bay

Measurements around and under all suction bell mouths

- Five (5) point pattern for each panel between longitudinals and floors

7.7.1(b) *Bottom, inner bottom and hopper structure longitudinals*

Minimum of three (3) longitudinals in each bay where bottom plating measured

- Three (3) measurements in line across flange and three (3) measurements on vertical web

7.7.1(c) *Bottom girders, including the watertight ones*

At fore and aft watertight floors and in center of tanks

- Vertical line of single measurements on girder plating with one (1) measurement between each panel stiffener, or a minimum of three (3) measurements

7.7.1(d) *Bottom floors, including the watertight ones*

Three (3) floors in bays where bottom plating measured, with measurements at both ends and middle

- Five (5) point pattern over a two (2) square meter area

7.7.1(e) *Hopper structure web frame ring*

Three (3) floors in bays where bottom plating measured

- Five (5) point pattern over one (1) square meter of plating. Single measurements on flange

7.7.1(f) *Hopper structure transverse watertight bulkhead or swash bulkhead*

Lower $\frac{1}{3}$ of bulkhead

- Five (5) point pattern over one (1) square meter of plating

Upper $\frac{2}{3}$ of bulkhead

- Five (5) point pattern over one (1) square meter of plating

Stiffeners [minimum of three (3)]

- For web, five (5) point pattern over span (two (2) measurements across web at each end and one (1) at center of span). For flange, single measurements at each end and center of span

7.7.1(g) *Panel stiffening*

Where applicable

- Single measurements

7.7.1(h) *Substantial Corrosion of more than 20%, in Chemical Carriers ESP (2010)*. In tanks in Chemical Carriers, where substantial corrosion covers more than 20% of the deck surface, the whole deck structure including longitudinals and web frames above the tank is to be thickness measured in accordance with the above.

7.7.2 Deck Structure

7.7.2(a) *Deck plating*

Two (2) transverse bands across tank

- Minimum of three (3) measurements per plate per band

7.7.2(b) *Deck longitudinals*

Every third longitudinal in each of two (2) bands with a minimum of one (1) longitudinal

- Three (3) measurements in line vertically on webs and two (2) measurements on flange (if fitted)

7.7.2(c) *Deck girders and brackets (usually in cargo tanks only)*

At fore and aft transverse bulkhead, bracket toes and in center of tanks

- Vertical line of single measurements on web plating with one (1) measurement between each panel stiffener, or a minimum of three (3) measurements.
- Two (2) measurements across flange. Five (5) point pattern on girder/bulkhead brackets

7.7.2(d) *Deck transverse webs*

Minimum of two (2) webs, with measurements at both ends and middle of span

- Five (5) point pattern over a one (1) square meter area.
- Single measurements on flange

7.7.2(e) *Vertical web and transverse bulkhead in wing ballast tank (two meters from deck)*

Minimum of two (2) webs, and both transverse bulkheads

- Five (5) point pattern over a one (1) square meter area

7.7.2(f) *Panel stiffening*

Where applicable

- Single measurements

7.7.3 Structure In Wing Ballast Tanks

7.7.3(a) *Side shell and longitudinal bulkhead plating:*

Upper strake and strakes in way of horizontal girders

Plating between each pair of longitudinals in a minimum of three (3) bays (along the tank)

- Single measurement

All other strakes

Plating between every third pair of longitudinals in same three (3) bays

- Single measurement

7.7.3(b) *Side shell and longitudinal bulkhead longitudinal on:*

Upper strake

Each longitudinal in same three (3) bays

- Three (3) measurements across web and one (1) measurement on flange

All other strakes

Every third longitudinal in same three (3) bays

- Three (3) measurements across web and one (1) measurement on flange

7.7.3(c) *Longitudinals – brackets*

Minimum of three (3) at top, middle and bottom of tank in same three (3) bays

- Five (5) point pattern over area of bracket

7.7.3(d) *Vertical web and transverse bulkheads (excluding deckhead area):*

Strakes in way of horizontal girders

Minimum of two (2) webs and both transverse bulkheads

- Five (5) point pattern over approximately a two (2) square meter area

Other strakes

Minimum of two (2) webs and both transverse bulkheads

- Two (2) measurements between each pair of vertical stiffeners

7.7.3(e) *Horizontal girders*

Plating on each girder in a minimum of three (3) bays

- Two (2) measurements between each pair of longitudinal girder stiffeners

7.7.3(f) *Panel stiffening*

Where applicable

- Single measurements

7.7.4 Longitudinal Bulkheads In Cargo Tanks

7.7.4(a) *Deckhead and bottom strakes, and strakes in way of the horizontal stringers of transverse bulkheads*

Plating between each pair of longitudinals in a minimum of three (3) bays

- Single measurement

7.7.4(b) *All other strakes*

Plating between every third pair of longitudinals in same three (3) bays

- Single measurement

7.7.4(c) *Longitudinals on deckhead and bottom strakes*

Each longitudinal in same three (3) bays

- Three (3) measurements across web and one (1) measurement on flange

7.7.4(d) *All other longitudinals*

Every third longitudinal in same three (3) bays

- Three (3) measurements across web and one (1) measurement on flange

7.7.4(e) *Longitudinals - brackets*

Minimum of three (3) at top, middle and bottom of tank in same three (3) bays

- Five (5) point pattern over area of bracket

7.7.4(f) *Web frames and cross ties*

Three (3) webs with minimum of three (3) locations on each web, including in way of cross tie connections

- Five (5) point pattern over approximately a two (2) square meter area of webs, plus single measurements on flanges of web frame and cross ties

7.7.4(g) *Lower end brackets (opposite side of web frame)*

Minimum of three (3) brackets

- Five (5) point pattern over approximately a two (2) square meter area of brackets, plus single measurements on bracket flanges

7.7.5 Transverse Watertight and Swash Bulkheads In Cargo Tanks

7.7.5(a) *Upper and lower stool, where fitted*

Transverse band within 25 mm of welded connection to inner bottom/deck plating

Transverse band within 25 mm of welded connection to shelf plate

- Five (5) point pattern between stiffeners over one (1) meter length

7.7.5(b) *Deckhead and bottom strakes, and strakes in way of horizontal stringers*

Plating between pair of stiffeners at three (3) locations: approximately $\frac{1}{4}$, $\frac{1}{2}$ and $\frac{3}{4}$ width of tank

- Five (5) point pattern between stiffeners over one (1) meter length

7.7.5(c) *All other strakes*

Plating between pair of stiffeners at middle locations

- Single measurement

7.7.5(d) *Strakes in corrugated bulkheads*

Plating for each change of scantling at center of panel and at flange of fabricated connection

- Five (5) point pattern over about one (1) square meter of plating

7.7.5(e) *Stiffeners*

Minimum of three (3) typical stiffeners

- For web, five (5) point pattern over span between bracket connections (two (2) measurements across web at each bracket connection and one (1) at center of span).
- For flange, single measurements at each bracket toe and at center of span

7.7.5(f) *Brackets*

Minimum of three (3) at top, middle and bottom of tank

- Five (5) point pattern over area of bracket

7.7.5(g) *Horizontal stringers*

All stringers with measurements at both ends and middle

- Five (5) point pattern over a one (1) square meter area, plus single measurements near bracket toes and on flanges

7.7.5(h) *Deep webs and girders (for Chemical Carriers) (2010)*

Measurements at toe of bracket and at center span

- For web, five (5) point pattern over about one (1) square meter. Three (3) measurements across face flat.

7.9 Bulk Carriers – Double Skin ESP and Bulk Carrier Features of Combination Carriers – Double Skin ESP (2005)

7.9.1 Bottom, Inner Bottom and Hopper Structure

7.9.1(a) *Bottom, Inner Bottom and Hopper Structure Plating*

Minimum of three bays across double bottom tank, including aft bay

- Five (5) point pattern for each panel between longitudinals and floors

Measurements around and under all suction bell mouths

7.9.1(b) *Bottom, Inner Bottom and Hopper Structure Longitudinals*

Minimum of three (3) longitudinals in each bay where bottom plating measured

- Three (3) measurements in line across flange and three (3) measurements on the vertical weld

7.9.1(c) *Bottom Girders, including the watertight ones*

At fore and aft watertight floors and in center tanks

- Vertical line of single measurements on girder plating with one measurement between each panel stiffener, or a minimum of three (3) measurements

7.9.1(d) *Bottom Floors, including the watertight ones*

Three floors in bays where bottom plating measured, with measurements at both ends and middle

- Five (5) point pattern over two (2) square meter area.

7.9.1(e) *Hopper Structure Web frame ring*

Three floors in bays where bottom plating measured

- Five (5) point pattern over one (1) square meter of plating. Single measurements on flange.

7.9.1(f) *Hopper Structure Transverse Watertight Bulkhead or Swash bulkhead*

Lower $\frac{1}{3}$ of bulkhead

- Five (5) point pattern over one (1) square meter of plating

Upper $\frac{2}{3}$ of bulkhead

- Five (5) point pattern over two (2) square meters of plating

Stiffeners (minimum of three)

- For web, five (5) point pattern over span (two measurements across web at each end and one at center of span). For flange, single measurements at each end and center of span

7.9.1(g) *Panel Stiffening*

Where applicable

- Single measurements

7.9.2 Deck Structure Including Cross Strips, Main Cargo Hatchways, Hatch Covers, Coamings and Topside Tanks

7.9.2(a) *Cross Deck Strip Plating*

Suspect Cross Deck Strip plating

- Five (5) point pattern between underdeck stiffeners over one (1) meter length

7.9.2(b) *Underdeck Stiffeners*

Transverse members

- Five (5) point pattern at each end and mid span

Longitudinal member

- Five (5) point pattern at both web and flange

7.9.2(c) *Hatch Covers*

Side and end skirts, each three locations

- Five (5) point pattern at each location

Three longitudinal bands, outboard strakes (2) and centerline strake (1)

- Five (5) point measurement each band

7.9.2(d) *Hatch Coamings*

Each side and end of coaming, one band lower $\frac{1}{3}$, one band upper $\frac{2}{3}$ of coaming

- Five (5) point measurement each band i.e. end or side coaming

7.9.2(e) *Topside Ballast Tanks*

Watertight transverse bulkheads

- Five (5) point pattern over one (1) square meter of plating

Lower $\frac{1}{3}$ of bulkhead

- Five (5) point pattern over one (1) square meter of plating

Upper $\frac{2}{3}$ of bulkhead

- Five (5) point pattern over one (1) square meter of plating

Stiffeners

- Five (5) point pattern over one (1) meter length

7.9.2(f) *Topside Ballast Tanks*

Two representative swash transverse bulkheads

- Five (5) point pattern over one (1) square meter of plating

Lower $\frac{1}{3}$ of bulkhead

- Five (5) point pattern over one (1) square meter of plating

Upper $\frac{2}{3}$ of bulkhead

- Five (5) point pattern over one (1) square meter of plating

Stiffeners

- Five (5) point pattern over one (1) meter length

7.9.2(g) *Topside Ballast Tanks*

Three representative bays of slope plating

- Five (5) point pattern over one (1) square meter of plating

Lower $\frac{1}{3}$ of bulkhead

- Five (5) point pattern over one (1) square meter of plating

Upper $\frac{2}{3}$ of bulkhead

- Five (5) point pattern over one (1) square meter of plating

Stiffeners

- Five (5) point pattern over one (1) meter length

7.9.2(h) *Topside Ballast Tanks*

Longitudinals, suspect and adjacent

- Five (5) point pattern on both web and flange over one (1) meter length

7.9.2(i) *Main Deck Plating*

Suspect Plates and adjacent (4)

- Five (5) point pattern over one (1) square meter of plating

7.9.2(j) *Main Deck Longitudinals*

Suspect Plates

- Five (5) point pattern on both web and flange over one (1) meter length

7.9.2(k) *Web Frames/Transverses*

Suspect Plates

- Five (5) point pattern over one (1) square meter

- 7.9.3 Structure in Double Side Spaces of Double Skin Bulk Carriers Including Wing Void Spaces of Ore Carriers
- 7.9.3(a) *Side shell and inner plating:*
- i) *Upper strake and strakes in way of horizontal girders*
Plating between each pair of transverse frames/longitudinals in a minimum of three bays (along the tank)
- Single measurement
- ii) *All other strakes*
Plating between every third pair of longitudinals in same three bays
- Single measurement
- 7.9.3(b) *Side shell and inner side transverse frames/longitudinals on:*
- i) *Upper strake*
Each transverse frame/longitudinal in same three bays
- Three (3) measurements across web and one (1) measurement on flange
- ii) *All other strakes*
Every third transverse frame/longitudinal in same three bays
- Three (3) measurements across web and one (1) measurement on flange
- 7.9.3(c) *Transverse frame/Longitudinals*
- i) *Brackets*
Minimum of three at top, middle and bottom of tank in same three bays
- Five-point (5) pattern over area of bracket
- 7.9.3(d) *Vertical web and transverse bulkheads:*
- i) *Strakes in a way of horizontal girders*
Minimum of two (2) webs and both transverse bulkheads
- Five-point (5) pattern over approximately two square meter area
- ii) *Other strakes*
Minimum of two webs and both transverse bulkheads
- Two (2) measurements between each pair of vertical stiffeners
- 7.9.3(e) *Horizontal girders*
Plating on each girder in a minimum of three bays
- Two (2) measurements between each pair of longitudinal girder stiffeners
- 7.9.3(f) *Panel stiffening*
Where applicable
- Single measurements

7.9.4 Transverse Bulkheads in Cargo Holds

7.9.4(a) Lower stool, where fitted

Transverse band within 25 mm of welded connection to inner bottom

- Five (5) point pattern between stiffeners over one (1) meter length

Transverse bands within 25 mm of welded connection to shelf plate

- Five (5) point pattern between stiffeners over one (1) meter length

7.9.4(b) Transverse bulkheads

Transverse band at approximately mid height

- Five (5) point pattern over one (1) square meter of plating

Transverse band at part of bulkhead adjacent to upper deck or below upper stool shelf plate (for those ships fitted with upper stools)

- Five (5) point pattern over one (1) square meter of plating

9 Preparations for Surveys of ESP Vessels (1 July 2014)

9.1 Survey Program

9.1.1 (1 July 2008)

The Owner in cooperation with ABS is to develop a specific Survey Program prior to the commencement of any part of:

- The Special Periodical Survey
- The Intermediate Survey for vessels over 10 years of age

The Survey Program is to be in a written format based on the information in 7-A-8/7 through 7-A-8/19 as applicable for each vessel type. The survey is not to commence until the Survey program has been agreed.

Prior to the development of the survey program, the survey planning questionnaire is to be completed by the Owner based on the information set out in 7-A-8/9 through 7-A-8/21, as applicable for each vessel type and forwarded to the attending Surveyor.

The Survey Program at Intermediate Survey may consist of the Survey Program at the previous Special Periodical Survey supplemented by the Condition Evaluation Report of that Special Periodical Survey and later relevant survey reports.

The Survey Program is to be developed taking into account any amendments to the survey requirements implemented after the last Special Periodical Survey carried out.

9.1.2 (1 July 2008)

The following documentation is to be collected and consulted with a view to selecting tanks, holds, areas and structural elements to be examined:

- Survey status and basic ship information.
- Documentation onboard, as described in the following paragraphs: 7-3-2/11.3 "Survey Report File" and 7-3-2/11.5 "Supporting Documents".
- Main structural plans of cargo and ballast tanks (scantlings and drawings), including information regarding use of higher strength steels.
- Condition Evaluation Report.
- Relevant previous damage and repair history.
- Relevant previous survey and inspection reports from both ABS and the Owner.

- Information regarding the use of the vessel's holds and tanks, typical cargoes and other relevant data.
- Cargo and ballast history for the last three (3) years, including carriage of cargo under heated conditions.
- Details of the inert gas plant and tank cleaning procedures.
- Information and other relevant data regarding conversion or modification of the vessel's cargo and ballast tanks since the time of construction.
- Description and history of the coating and corrosion protection system (previous class notations) if any.
- Inspections by the Owner's personnel during the last three (3) years with reference to structural deterioration in general, leakages in tank boundaries and piping, and condition of the coating and corrosion protection system, if any.
- Information regarding the relevant maintenance level during operation including port state control reports of inspection containing hull related deficiencies and Safety Management System non-conformities relating to hull maintenance, including the associated corrective action(s).
- Any other information that will help identify suspect areas and critical structural areas.

9.1.3 (2012)

Survey program is to account for and comply, as a minimum, with the requirements of close-up survey, thickness measurement, tank testing, and pipe testing, and is to consider relevant information including at least:

- Basic ship information and particulars.
- Main structural plans, including information regarding use of higher strength steels, clad steel and stainless steel.
- Plan of holds and tanks.
- List of holds and tanks with information on use, corrosion prevention system and condition of coating.
- Conditions for survey (e.g., information regarding tank cleaning, gas freeing, ventilation, lighting, etc.).
- Provisions and methods for access to structures.
- Equipment for surveys.
- Holds and tanks, and areas selected for Close-up Survey.
- Structures selected for Thickness Measurement.
- Tanks selected for Tank Testing and the pipes that are to undergo pipe testing as per 7-3-2/5.21.7.
- Damage experience related to the vessel.
- Identification of the thickness measurement company.
- Critical structural areas and suspect areas, where relevant.

9.1.4

ABS will advise the Owner of the maximum acceptable structural wastage allowances applicable to the vessel.

9.1.5 (1 July 2005)

"Guidelines for Technical Assessment in Conjunction with Planning for Enhanced Surveys" may be referred to in conjunction with the Survey program preparation (see Appendix 7-A-8).

9.2 Survey Planning Meeting (1 July 2008)

9.2.1

The establishment of proper preparation and the close co-operation between the attending Surveyor(s) and the Owner's representatives onboard prior to and during the survey are an essential part in the safe and efficient conduct of the survey. During the survey onboard safety meetings are to be held regularly.

9.2.2 (2010)

Prior to commencement of any part of the Special Periodical and Intermediate Survey, a survey planning meeting is to be held between the attending Surveyor(s), the Owner's representative in attendance, the Thickness Measurement company operator (as applicable) and the master of the vessel or an appropriately qualified representative appointed by the master or company for the purpose to ascertain that all the arrangements envisaged in the survey program are in place, so as to ensure the safe and efficient conduct of the survey work to be carried out. See also 7-3-2/13.1.

9.2.3

The following is an indicative list of items that are to be addressed in the meeting:

- Schedule of the vessel (i.e., the voyage, docking and undocking maneuvers, periods alongside, cargo and ballast operations, etc.).
- Provisions and arrangements for thickness measurements (i.e., access, cleaning/de-scaling, illumination, ventilation, personal safety).
- Extent of the thickness measurements.
- Acceptance criteria (refer to the list of minimum thicknesses).
- Extent of close-up survey and thickness measurement considering the coating condition and suspect areas/areas of substantial corrosion.
- Execution of thickness measurements.
- Taking representative readings in general and where uneven corrosion/pitting is found.
- Mapping of areas of substantial corrosion.
- Communication between attending Surveyor(s), the Thickness Measurement company operator(s), and Owner's representative(s) concerning findings.

9.3 Survey at Sea or at Anchorage (1 July 2004)

In addition to 7-3-1/9, the following requirements are to be complied with:

9.3.1

Rafts or boats alone may be allowed for inspection of the under deck areas for tanks or spaces, if the depth of the webs is 1.5 m or less.

9.3.2

If the depth of the webs is more than 1.5 m, rafts or boats alone may be allowed only:

- i) When the coating of the under deck structure is in GOOD condition and there is no evidence of wastage; or
- ii) (2007) If a permanent means of access is provided in each bay to allow safe entry and exit. This means:
 - Access direct from the deck via a vertical ladder and a small platform fitted approximately 2 m below the deck in each bay; or

- Access to deck from a longitudinal permanent platform having ladders to deck in each end of the tank. The platform is to, for the full length of the tank, be arranged in level with, or above, the maximum water level needed for rafting of under deck structure. For this purpose, the ullage corresponding to the maximum water level is to be assumed not more than 3 m from the deck plate measured at the midspan of deck transverses and in the middle length of the tank (See 7-3-2/Figure 1).

If neither of the above conditions is met, then staging or an “other equivalent means” is to be provided for the survey of the under deck areas.

FIGURE 1 (2007)

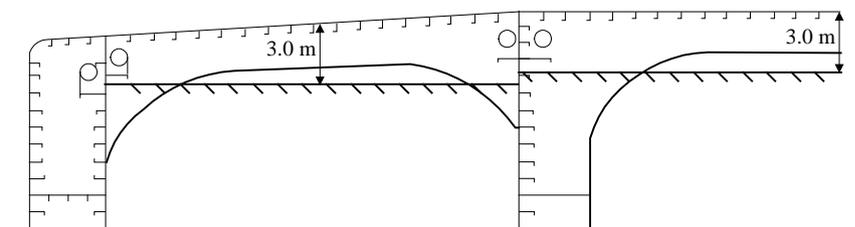

9.3.3

The use of rafts or boats alone in paragraphs 7-3-2/9.3.1 and 7-3-2/9.3.2 does not preclude the use of boats or rafts to move about within a tank during a survey.

9.3.4 (1 July 2008)

When rafts or boats will be used for close-up survey, the following conditions are to be observed:

- i) Only rough duty, inflatable rafts or boats, having satisfactory residual buoyancy and stability even if one chamber is ruptured, are to be used;
- ii) The boat or raft is to be tethered to the access ladder and an additional person is to be stationed down the access ladder with a clear view of the boat or raft;
- iii) Appropriate lifejackets are to be available for all participants;
- iv) The surface of water in the tank or hold is to be calm (under all foreseeable conditions, the expected rise of water within the tank is not to exceed 0.25 m) and the water level stationary. On no account, is the level of the water to be rising while the boat or raft is in use.
- v) The tank, hold or space must contain clean ballast water only. Even a thin sheen of oil on the water is not acceptable; and
- vi) At no time is the water level to be allowed to be within 1 m of the deepest under deck web face flat so that the survey team is not isolated from a direct escape route to the tank hatch. Filling to levels above the deck transverses is only to be contemplated if a deck access manhole is fitted and open in the bay being examined, so that an escape route for the survey party is available at all times. Other effective means of escape to the deck may be considered.
- vii) If the tanks (or spaces) are connected by a common venting system, or inert gas system, the tank in which the boat or raft should be used should be isolated to prevent a transfer of gas from other tanks (or spaces).

9.5 Conditions for Survey (2016)

9.5.1

The Owner is to provide the necessary facilities for a safe execution of the survey.

9.5.2 (2016)

In order to enable the attending Surveyors to carry out the survey, provisions for proper and safe access, are to be agreed between the Owner and the Surveyor and be in accordance with the ABS Health & Safety Manual.

9.5.3

Details of the means of access are to be provided in the survey planning questionnaire.

9.5.4

In cases where the provisions of safety and required access are judged by the attending Surveyor(s) to be inadequate, the survey of the spaces involved is not to proceed.

9.5.5

Cargo holds, tanks, and spaces are to be safe for access. Cargo holds, tanks, and spaces are to be gas free and properly ventilated. Prior to entering a tank, void or enclosed space, it is to be verified that the atmosphere in the tank is free from hazardous gas and contains sufficient oxygen.

9.5.6

In preparation for survey and thickness measurements and to allow for a thorough examination, all spaces are to be cleaned, including removal from surfaces of all loose accumulated corrosion scale. Spaces are to be sufficiently clean and free from water, scale, dirt, oil residues, etc., to reveal corrosion, deformation, fractures, damages, or other structural deterioration, as well as the condition of the coating. However, those areas of structure whose renewal has already been decided by the Owner need only be cleaned and descaled to the extent necessary to determine the limits of the areas to be renewed.

9.5.7

Sufficient illumination is to be provided to reveal corrosion, deformation, fractures, damages, or other structural deterioration, as well as the condition of the coating.

9.5.8

Where soft or semi-hard coatings have been applied, safe access is to be provided for the Surveyor to verify the effectiveness of the coating and to carry out an assessment of the conditions of internal structures which may include spot removal of the coating. When safe access cannot be provided, the soft or semi-hard coating is to be removed.

9.7 Equipment for Survey (1 July 2008)

9.7.1

Thickness measurement is normally to be carried out by means of ultrasonic test equipment. The accuracy of the equipment is to be proven to the Surveyor, as required.

9.7.2

One or more of the following fracture detection procedures may be required if deemed necessary by the Surveyor:

- Radiographic examination.
- Ultrasonic examination.
- Magnetic particle examination.
- Dye penetrant examination.

9.7.3

Explosimeter, oxygen-meter, breathing apparatus, lifelines, riding belts with rope and hook, and whistles together with instructions and guidance on their use are to be made available during the survey. A safety check-list is to be provided.

9.7.4

Adequate and safe lighting is to be provided for the safe and efficient conduct of the survey.

9.7.5

Adequate protective clothing is to be made available and used (e.g., safety helmet, gloves, safety shoes, etc.) during the survey.

10 Preparations for Surveys of ESDC Vessels (1 July 2014)

10.1 Survey Planning

A survey planning meeting is to be held prior to the commencement of the Special Periodical Surveys and Intermediate Surveys. See also 7-3-2/13.1.

The survey plan is to be in a written format. Refer to 7-A-8/1 for a sample plan.

Survey planning is to account for and comply with the requirements of close-up survey, thickness measurement and tank testing, and is to consider relevant information including at least:

- Basic ship information and particulars.
- Main structural plans, including information regarding use of higher strength steels.
- Plan of holds and tanks.
- List of holds and tanks with information on use, corrosion prevention system and condition of coating.
- Conditions for survey (e.g., information regarding tank cleaning, gas freeing, ventilation, lighting, etc.).
- Provisions and methods for access to structures.
- Equipment for surveys.
- Holds and tanks, and areas selected for Close-up Survey.
- Structures selected for Thickness Measurement.
- Tanks selected for Tank Testing.
- Damage experience related to the vessel.

10.3 Survey at Sea or at Anchorage

Refer to 7-3-2/9.3.

11 Documentation on Board ESP Vessels

11.1 General (2016)

The Owner is to obtain, supply and maintain onboard documentation, as specified in the following paragraphs “Survey Report File” and “Supporting Documents”, which is to be readily available for the Surveyor. The documentation is to be kept onboard for the lifetime of the ship.

For tankers and bulk carriers subject to SOLAS Chapter II-1 Part A-1 Regulation 3-10, the Owner is to arrange the updating of the Ship Construction File (SCF) throughout the ship’s life whenever a modification of the documentation included in the SCF has taken place. Documented procedures for updating the SCF are to be included within the Safety Management System.

11.3 Survey Report File

A Survey Report File is to be a part of the documentation on board consisting of:

- Reports of structural surveys.
- Condition Evaluation Report.
- Thickness measurement reports.
- Survey plan, as noted in the preceding paragraph 7-3-2/9.1 “Survey Program”.

The Survey Report File is also to be available in the Owner’s management office.

11.5 Supporting Documents

The following additional documentation is to be available onboard:

11.5.1 (1 July 2013)

Main structural plans of cargo holds, cargo and ballast tanks (for CSR ships these plans are to include for each structural member both the as-built and renewal thickness. Any thickness for voluntary addition is also to be clearly indicated on the plans. The main structural plans to be supplied on board the ship are to include the minimum allowable hull girder sectional properties for hold or tank transverse sections in all cargo holds or tanks).

11.5.2

Previous repair history.

11.5.3

Cargo and ballast history.

11.5.4

Extent of use of inert gas plant and tank cleaning procedures.

11.5.5 (1 July 2006)

Inspections and actions taken by ship’s personnel with reference to:

- Structural deterioration in general.
- Leakage in bulkheads and piping.
- Condition of corrosion prevention system, if any.

A guidance for reporting is shown in 7-A-8/5 titled “Owners Inspection Report”.

11.5.6 (2016)

Any other information that will help to identify critical structural areas and/or suspect areas requiring inspection. For tankers and bulk carriers subject to SOLAS Chapter II-1 Part A-1 Regulation 3-10, the Ship Construction File (SCF), limited to the items to be retained on board, is to be available on board.

11.7 Review of Documentation on Board (2016)

11.7.1

Prior to commencing survey of hull structure, the Surveyor is to examine the completeness of the documentation onboard and its contents as a basis for the survey.

11.7.2

For tankers and bulk carriers subject to SOLAS Chapter II-1 Part A-1 Regulation 3-10, on completion of the survey, the surveyor is to verify that the update of the Ship Construction File (SCF) has been done whenever a modification of the documentation included in the SCF has taken place.

11.7.3

For tankers and bulk carriers subject to SOLAS Chapter II-1 Part A-1 Regulation 3-10, on completion of the survey, the surveyor is to verify any addition and/or renewal of materials used for the construction of the hull structure are documented within the Ship Construction File inventory list.

12 Documentation on Board General Dry Cargo Vessels (ESDC) (2004)

The Owner is to supply and maintain onboard survey and thickness measurement reports, which are to be readily available for the Surveyor. Prior to commencing Structural Hull surveys, the Surveyor is to examine the documentation onboard as a basis for the survey.

The documentation is to be kept onboard for the lifetime of the vessel.

13 Procedure for Thickness Measurements of ESP Vessels and General Dry Cargo Vessels (ESDC) (2004)

13.1 General (1 July 2002)

The required thickness measurements are to be witnessed by the Surveyor, who is to be onboard to the extent necessary to control the process.

The thickness measurement company is to be part of a survey planning meeting to be held prior to commencing the survey.

(2007) Thickness measurements of structures in areas where close-up surveys are required are to be carried out simultaneously with close-up surveys.

(1 July 2008) In all cases, the extent of thickness measurements is to be sufficient as to represent the actual average condition.

13.3 Certification of Thickness Measurement Company

The thickness measurements are to be carried out by a qualified company certified by ABS, according to principles stated in Appendix 7-A-5 "Procedures for Certification of Firms Engaged in Thickness Measurements of Hull Structures".

13.5 Reporting (1 July 2006)

A thickness measurement report is to be prepared and submitted to the attending Surveyor. The report is to give the location of measurements, together with the corresponding original thickness and maximum allowable diminution and the thickness measured. Furthermore, the report is to give the date when the measurements were carried out, type of measuring equipment, names of personnel and their qualifications and has to be signed by the operator. The thickness measurement report is to follow the principles as specified in Appendix 7-A-6 for Bulk Carriers and General Dry Cargo Vessels, Appendix 7-A-7 for Oil Carriers and Chemical Carriers Non-Double Hull, Appendix 7-A-13 for Double Hull Oil Carriers and Appendix 7-A-15 for Double Skin Bulk Carriers.

The Surveyor is to review the final thickness measurement report and countersign the cover page.

15 Reporting and Evaluation of Surveys of ESP Vessels (2004)

15.1 Evaluation of Survey Report (2004)

15.1.1

The data and information on the structural condition of the vessel collected during the survey is to be evaluated for acceptability and continued structural integrity of the vessel.

15.1.2 (1 July 2013)

For oil tankers 130 m (427 ft) in length and larger (as defined in the current International Convention on Load Lines), the vessel's longitudinal strength is to be evaluated by using the actual thickness of structural members measured during each Special Periodical Survey carried out after the vessel has reached 10 years of age. Structural members may be subject to renewal or reinforcement, as appropriate and determined by the survey. The longitudinal strength evaluation is to be made in accordance with the criteria for longitudinal strength of oil tankers' hull girders specified in 7-A-4/33.

For CSR bulk carriers, the ship's longitudinal strength is to be evaluated by using the thickness of structural members measured, renewed and reinforced, as appropriate, during the special surveys carried out after the ship reached 15 years of age (or during the special survey no. 3, if this is carried out before the ship reaches 15 years) in accordance with the criteria for longitudinal strength of the ship's hull girder for CSR bulk carriers specified in Part 5A, Pt 1, Ch 13 of CSR.

The final result of the evaluation of the vessel's longitudinal strength, including any renewal or reinforcement work carried out as a result of the initial evaluation, is to be submitted to ABS for Approval and is to be reported as a part of the Condition Evaluation Report.

15.3 Reporting (1 July 2006)

When a survey is split between different survey stations, a report is to be made for each portion of the survey. A list of items examined and/or tested (pressure testing, thickness measurements etc.) and an indication of whether the item has been credited are to be made available to the next attending Surveyor(s) prior to continuing or completing the survey.

Principles for reporting are shown in Appendix 7-A-9 "Reporting Principles".

A Condition Evaluation Report of the survey and results as shown in 7-A-9/Reports 1 and 2 is to be issued to the Owner and placed onboard the vessel for reference at future surveys.

PART
7

CHAPTER 3 Hull Surveys

SECTION 3 Vessels in Great Lakes Service

Except as noted below, the requirements for vessels in Unrestricted Service in Section 7-3-2 apply to vessels in Great Lakes Service.

The ESP and ESDC vessel requirements do not apply to vessels in Great Lakes Service.

1 Definitions (2012)

Ballast tank - For Great Lakes service a ballast tank is a tank which is used primarily for the carriage of fresh water ballast.

3 Annual Hull Surveys (2012)

3.1 Bulk Carriers

3.1.1

Overall survey of a minimum of three (3) representative ballast tanks selected by the Surveyor is to be carried out. Where substantial corrosion or structural damage is found the remaining ballast tanks may also be required to be examined as considered necessary by the attending Surveyor.

5 Intermediate Surveys

5.1 Bulk Carriers and Combination Carriers

5.1.1

This survey is to include examination of the hatch side girders and/or upper deck plating inside the hatch coaming, together with associated internals so far as can be seen.

5.1.2

At least three (3) ballast tanks, one (1) peak tank and two (2) cargo holds are to be internally examined. Where substantial corrosion or structural damage is found, the remaining spaces may also be required to be examined.

7 Special Periodical Surveys

7.1 All Special Periodical Surveys

7.1.1

At the discretion of the Surveyor, the testing of tanks required by 7-3-2/5.1.10 may be waived for tanks other than cargo tanks for tankers, provided an internal examination is carried out, where required elsewhere, together with an examination of the tank top.

7.1.2 (2012)

In general, the thickness Measurements as per 7-3-2/5.1.9 do not apply to Great Lakes Vessels, except as noted in 7-3-3/7.5.

7.1.3

In any part of the vessel where wastage is evident or suspect, the Surveyor may require thickness measurements in order to obtain the actual thickness of the material.

7.3 Special Periodical Survey No. 3 and Subsequent Special Periodical Surveys

7.3.1

For Great Lakes vessels having the additional St. Lawrence River Service notation and operating in the St. Lawrence River, particular attention is directed to unprotected ballast tanks. Where extensive corrosion is found, thickness measurements are to be carried out.

7.3.2

For Great Lakes vessels designed for and granted restricted service into the Gulf of St. Lawrence, and which are found with extensive corrosion, thickness measurements are to be carried out that may be equal to those required for full Ocean service.

7.5 Special Periodical Survey No. 7 and Subsequent Special Periodical Surveys (2012)

As a minimum, at least one (1) belt near amidships to include deck, side shell, bottom and internals in way is to be thickness measured. In addition, confirmatory thickness measurements are to be taken in way of the lower strakes of transverse structural bulkheads and port and starboard lower hopper slope plating in all cargo holds.

9 Year of Grace Surveys

The requirements for surveys to qualify for a period of grace will normally include the internal examination of peaks, some ballast tanks and cargo holds. Outstanding recommendations are to be re-examined and found or placed in a condition acceptable to the attending Surveyor.

11 Drydocking Surveys

After satisfactory external examination of the non-metallic expansion pieces in the main seawater circulating system, the internal examination may be waived by the attending Surveyor. However, the Surveyors are to be notified should such non-metallic expansion pieces become accessible for internal examination.

PART

7

CHAPTER 3 Hull Surveys

SECTION 4 Vessels in Rivers and Intracoastal Waterways Service

Except as noted below, the requirements for vessels in Unrestricted Service in Section 7-3-2 apply to vessels in Rivers and Intracoastal Waterways Service.

The ESP and ESDC vessel requirements do not apply to vessels in Rivers and Intracoastal Waterways Service.

1 Special Periodical Surveys

1.1 Surveys on Drydocked Vessels

For vessels which have been surveyed on drydock approximately one year before the commencement of Special Periodical Survey, no further dry docking will be required, provided all requirements incidental to the Drydocking Survey are completed satisfactorily.

1.3 Thickness Measurements

In lieu of the thickness measurements required by 7-3-2/5.1.9, where, owing to the condition of the vessel, the Surveyor deems it necessary, the thicknesses of the shell and deck and such other parts of the vessel as are liable to excessive corrosion are to be determined.

PART
7

CHAPTER 4 Drydocking Surveys

CONTENTS

SECTION 1	Survey Requirements.....	139
1	All Vessels.....	139
3	Accommodation Barges.....	140
3.1	Displacement Hulls.....	140
5	Vessels Constructed of Aluminum Alloys.....	140
7	High Speed Craft Constructed of FRP.....	140

PART
7

CHAPTER 4 Drydocking Surveys

SECTION 1 Survey Requirements

1 All Vessels (2004)

(2005) When a vessel is in drydock or on a slipway, it is to be placed on blocks of sufficient height and with the necessary staging to permit the examination of the following items which are to be cleaned, as necessary, and examined together with appendages, as applicable, and placed in satisfactory condition:

- i) Keel
- ii) Stem
- iii) Stern frame and post
- iv) (2008) Bottom Plug arrangements
- v) (2005) Side and bottom plating externally. The shell plating is to be examined for excessive corrosion, or deterioration due to chafing or contact with the ground and for any undue unfairness or buckling. Plate unfairness or other deterioration which does not necessitate immediate repairs is to be recorded.
- vi) (2005) Bow plating externally
- vii) Rake plating externally
- viii) (2005) Visible parts of the rudder. If considered necessary by the Surveyor, the rudder is to be lifted.
- ix) (2005) Visible parts of rudder shafts and couplings
- x) (2014) Rudder pintles and gudgeons together with their respective securing arrangements. Inspection covers or access plates are to be removed for the examination of pintles and securing arrangements.
- xi) Rudder pressure test, where applicable, as deemed necessary by the Surveyor
- xii) Rudder bearing clearances are to be ascertained and reported on
- xiii) (2014) Propeller nozzle
- xiv) Exposed parts of the stern bearing and seal assembly. (See Note below.)
- xv) The stern bearing clearance or wear-down is to be ascertained and reported on. (See Note below.)
- xvi) (1 July 2015) Visible parts of the propeller. Each taper fitted propeller hub with greater than 10 years of service life is to be examined by a surface crack-detection method at each out of the water drydocking, or whenever the propeller is removed for any reason.
- xvii) Controllable pitch propeller hub fastenings and tightness. (See Note below.)
- xviii) Controllable pitch propeller blade fastenings and tightness. (See Note below.)
- xix) The efficiency of the oil gland, if fitted, is to be ascertained and reported on. (See Note below.)
- xx) Bilge keels, with special attention paid to the connection between the bilge strakes and the bilge keels.

- xxi) (1 July 2014) Visible parts of athwartship thrusters are to be examined. Other propulsion systems which also have maneuvering characteristics (such as directional propellers, vertical axis propellers, water jet units) are to be examined externally with focus on the condition of gear housing, propeller blades, bolt locking and other fastening arrangements. Sealing arrangement of propeller blades, propeller shaft and steering column shall be verified.
- xxii) Sea chests and their gratings
- xxiii) (2005) Sea connections and overboard discharge valves and cocks, including their attachments to the hull or sea chests, are to be externally examined. Valves and cocks need not be opened up more than once in a Special Periodical Survey period unless considered necessary by the Surveyor.
- xxiv) All nonmetallic expansion pieces in the sea-water cooling and circulating systems are to be externally examined
- xxv) Nonmetallic expansion pieces in the main sea-water circulating systems are to be examined both externally and internally when vessel is examined on drydock
- xxvi) (1 July 2015) Special attention is to be paid to all weldments of the ESD (energy saving device) in way of its connection to the hull or rudder blade plating as applicable.
- xxvii) (1 July 2015) The exposed steel of the tailshaft is to be protected from the action of the water by filling all spaces between cap, hub and shaft with a suitable material. Once the cap/cone is installed, bolts are to be tightened, visually examined and are to be secured using a locking mechanism.

Note: (2005) Dismantling need not be carried out unless considered necessary by the Surveyor

For Special Periodical Survey of underwater items, refer to 7-6-2/3.1.1 and 7-3-2/5.

3 Accommodation Barges

In addition to the applicable requirements of 7-4-1/1, the Drydocking Survey (or equivalent) is also to include the following:

3.1 Displacement Hulls

For Displacement Hulls, external surfaces of the hull plating together with sea chest, strainers and fastenings are to be cleaned and examined.

5 Vessels Constructed of Aluminum Alloys

In addition to the applicable requirements of 7-4-1/1, the Drydocking Survey (or equivalent) is also to include the following:

Underwater aluminum plating in close proximity to dissimilar metal is to be examined both internally and externally, as far as practicable.

7 High Speed Craft Constructed of FRP

In addition to the applicable requirements of 7-4-1/1, the Drydocking Survey (or equivalent) is also to include the following:

The hauling and supporting of an FRP craft when out of the water is not part of the ABS review. Extreme caution is to be taken on the blocking of an FRP craft. Blocks are to be placed along the keel and pads are to be placed on structural bulkheads.

PART
7

CHAPTER 5 Tailshaft Surveys

CONTENTS

SECTION 1	Survey Requirements	143
1	General	143
3	Definitions	143
3.1	Shaft.....	143
3.3	Propeller Shaft.....	143
3.5	Tube Shaft.....	143
3.7	Stern Tube.....	143
3.9	Closed Loop (System) Oil Lubricating Bearing.....	143
3.11	Water Lubricated Bearing.....	143
3.13	Closed Loop System Fresh Water Lubricated Bearing.....	143
3.15	Open Systems (Water).....	143
3.17	Adequate Means for Protection Against Corrosion.....	144
3.19	Corrosion Resistant Shaft.....	144
3.21	Stern Tube Sealing System.....	144
3.23	Service Records	144
3.25	Oil Sample Examination	144
3.27	Lubricating Oil Analysis	144
3.29	Fresh Water Sample Test.....	144
3.31	Keyless Connection.....	145
3.33	Keyed Connection	145
3.35	Flanged Connection	145
3.37	Alternative Means.....	145
5	Oil Lubricated Shafts or Closed Loop System Fresh Water Lubricated Shafts (Closed System)	145
5.1	Shaft Survey Methods	145
5.3	Shaft Extension Surveys – Extension Types	147
7	Water Lubricated Shafts (Open Systems)	148
7.1	Shaft Survey Methods	148
7.3	Shaft Extension Surveys – Extension Types	148
9	Vessels in Great Lakes Service	149
9.1	Tailshaft Survey.....	149
SECTION 2	Allowable Bearing Weardown	150
1	Vessels for Unrestricted Service and in Rivers and Intracoastal Waterways Services	150
1.1	Water-Lubricated Bearing Other than Rubber.....	150
1.3	Water-Lubricated Rubber Bearing.....	150
1.5	Oil-Lubricated Bearings	150

3	Vessels in Great Lakes Service	150
3.1	Water-Lubricated Bearings Other than Rubber	150
3.3	Rubber and Oil-Lubricated Bearings.....	150

PART
7

CHAPTER 5 Tailshaft Surveys

SECTION 1 Survey Requirements

1 General (2016)

The following Methods are to be adhered to when conducting Tailshaft Surveys

3 Definitions (2016)

3.1 Shaft

For the purposes of this requirement the shaft definition includes:

- Propeller Shaft
- Tube Shaft

3.3 Propeller Shaft

Propeller Shaft is the part of the propulsion shaft to which the propeller is fitted. It may also be the screw shaft or tailshaft.

3.5 Tube Shaft

Tube shaft is a shaft placed between the intermediate shaft and propeller shaft, normally arranged with the stern tube or running in open water. It may also be called the Stern Tube Shaft.

3.7 Stern Tube

Tube or pipe fitted in the shell of a ship at the stern (or rear part of the ship), below the water-line, through which passes the tube shaft or aftermost section of the propeller shaft. The stern tube is the housing of the shaft bearings, generally two (one aft and one fore), that sustain the shaft and allows its rotation with less frictional resistance. The stern tube also accommodates the shaft sealing arrangements.

3.9 Closed Loop (System) Oil Lubricating Bearing

Closed loop oil lubricating systems use oil to lubricate the bearings and are sealed against the environment (seawater) by adequate sealing/gland devices.

3.11 Water Lubricated Bearing

Water lubricated bearings are bearings cooled/lubricated by water (fresh or salt).

3.13 Closed Loop System Fresh Water Lubricated Bearing

Closed loop water lubricating systems use fresh water to lubricate the bearings and are sealed against the environment (such as seawater) by adequate sealing/gland devices.

3.15 Open Systems (Water)

Open water lubricating systems use water to lubricate the bearings and are exposed to the environment.

3.17 Adequate Means for Protection Against Corrosion

An adequate means for protection against corrosion is an approved means for full protection of the core shaft against sea water intrusion and subsequent corrosion attack. Such means are used for the protection of common steel material against corrosion particularly in combination with water lubricated bearings.

Typical examples are:

- Continuous metallic, corrosion resistant liners
- Continuous cladding per 4-3-2/5.17.5
- Multiple layer synthetic coating
- Multiple layers of fiberglass per 4-3-2/5.17.4
- Combinations of the above mentioned
- Rubber/elastomer covering coating

3.19 Corrosion Resistant Shaft

A corrosion resistant shaft is made in approved corrosion resistant steel as core material for the shaft

3.21 Stern Tube Sealing System

Stern tube Sealing System is the equipment installed on the inboard extremity and, for closed systems, at the outboard extremity of the stern tube. The inboard seal is the device fitted on the fore part of the stern tube that achieve the sealing against the possible leakage of the lubricant media. The outboard seal is the device fitted on the aft part of the stern tube that achieve the sealing against the possible sea water ingress and the leakage of the lubricant media.

3.23 Service Records

Service Records are regularly recorded data showing in-service conditions of the shaft(s) and may include, as applicable; lubricating oil temperature, bearing temperature and oil consumption records (for oil lubricated bearings) or water flow, water temperature, salinity, pH, make-up water and water pressure (for closed loop fresh water lubricated bearings depending on design).

3.25 Oil Sample Examination

An oil sample examination is a visual examination of the stern tube lubricating oil taken in the presence of the surveyor with a focus on water contamination.

3.27 Lubricating Oil Analysis

Lubricating oil analysis is to be carried out at regular intervals not exceeding six (6) months. The documentation on lubricating oil analysis is to be available on board. Oil samples submitted for analysis should be taken under service condition

3.29 Fresh Water Sample Test

Fresh water sample test should be carried out at regular intervals not exceeding six (6) months. Samples are to be taken under service conditions and are to be representative of the water circulating within the stern tube. Analysis results are to be retained on board and made available to the surveyor. At the time of survey the sample for the test must be taken in the presence of the Surveyor.

Fresh water sample tests shall include the following parameters:

- Chlorides content
- pH value
- Presence of bearing particles or other particles (only for laboratory analysis, not required for tests carried out in the presence of the Surveyor).

3.31 Keyless Connection

The keyless connection is the forced coupling methodology between the shaft and the propeller without a key achieved through interference fit of the propeller boss on the shaft tapered end.

3.33 Keyed Connection

The keyed connection is the forced coupling methodology between the shaft and the propeller with a key and a keyway achieved through the interference fit of the propeller boss on the shaft tapered end.

3.35 Flanged Connection

The flanged connection is the coupling methodology, between the shaft and the propeller, achieved by a flange, built in at the shaft end, bolted to the propeller boss.

3.37 Alternative Means (2017)

Shafting arrangements such as, but not limited to, an approved Condition Monitoring Scheme and/or another reliable approved means for assessing and monitoring the condition of the tail shaft, bearings, sealing devices and the stern tube lubricant system which is capable of assuring the condition of the propeller shaft assembly with an equivalent level of safety as obtained by survey methods as applicable in Section 7-5-1.

5 Oil Lubricated Shafts or Closed Loop System Fresh Water Lubricated Shafts (Closed System) (2016)

When the propeller is removed for any reason, the propeller hub is to be examined by a surface crack detection method after reinstallation. Controllable-pitch propellers are to be surveyed along with the tailshaft. The propeller is to be function tested, examined for blade seal leaks, and opened out as deemed necessary by the attending Surveyor.

5.1 Shaft Survey Methods

5.1.1 Method 1

The survey is to consist of:

- Drawing the shaft and examining the entire shaft, seals system and bearings
- For keyed and keyless connections:
 - Removing the propeller to expose the forward end of the taper,
 - Performing a nondestructive examination (NDE) by a surface crack detection method all around the shaft in way of the forward portion of the taper section, including the keyway (if fitted). For shaft provided with liners, the NDE shall extended to the after edge of the liner.
- For flanged connection:
 - Whenever the coupling bolts of any type of flange-connected shaft are removed or the flange radius is made accessible in connection with overhaul, repairs, or when deemed necessary by the Surveyor, the coupling bolts and flange radius are to be examined by means of an approved surface crack detection method.
- Checking and recording the bearing clearances.
- Verification that the propeller is free of damages which may cause the propeller to be out of balance.
- Bearing inboard seal assemblies are to be externally examined and to be found or placed in a satisfactory condition.
- Bearing outboard seals are to be renewed and the seal liner found to be or placed in a satisfactory condition.
- Recording the bearing wear-down measurements (after re-installation)

5.1.2 Method 2

The survey is to consist of:

- For keyed and keyless connections:
 - Removing the propeller to expose the forward end of the taper,
 - Performing a nondestructive examination (NDE) by a surface crack detection method all around the shaft in way of the forward portion of the taper section, including the keyway (if fitted).
- For flanged connection:
 - Whenever the coupling bolts of any type of flange-connected shaft are removed or the flange radius is made accessible in connection with overhaul, repairs, or when deemed necessary by the Surveyor, the coupling bolts and flange radius are to be examined by means of a an approved surface crack detection method.
- Checking and recording the bearing wear down measurements.
- Visual Inspection of all accessible parts of the shafting system.
- Verification that the propeller is free of damages which may cause the propeller to be out of balance.
- Seal liner found to be or placed in a satisfactory condition.
- Bearing inboard seal assemblies are to be externally examined and to be found or placed in a satisfactory condition.
- Bearing outboard seals are to be renewed and the seal liner found to be or placed in a satisfactory condition.
- Review of service records.
- Review of test records of:
 - Lubricating Oil analysis (for oil lubricated shafts), or
 - Fresh Water Sample test (for closed system fresh water lubricated shafts).
- Oil Sample Examination (for oil lubricated shafts), or Fresh Water Sample test (for closed system fresh water lubricated).
- Verification of no reported repairs by grinding or welding of shaft and/or propeller.

5.1.3 Method 3

The survey is to consist of:

- Checking and recording the bearing wear down measurements.
- Visual Inspection of all accessible parts of the shafting system. Verification that the propeller is free of damages which may cause the propeller to be out of balance.
- Seal liner found to be or placed in a satisfactory condition.
- Verification of the satisfactory conditions of inboard and outboard seals.
- Review of service records.
- Review of test records of:
 - Lubricating Oil analysis (for oil lubricated shafts), or
 - Fresh Water Sample test (for closed system fresh water lubricated shafts).
- Oil Sample Examination (for oil lubricated shafts), or Fresh Water Sample test (for closed system fresh water lubricated).
- Verification of no reported repairs by grinding or welding of shaft and/or propeller.

5.3 Shaft Extension Surveys – Extension Types

5.3.1 Extension Up to 2.5 Years

The survey is to consist of:

- Checking and recording the bearing wear measurements, as far as practicable.
- Visual Inspection of all accessible parts of the shafting system.
- Verification that the propeller is free of damages which may cause the propeller to be out of balance.
- Verification of the effectiveness of the inboard seal and outboard seals.
- Review of service records.
- Review of test records of:
 - Lubricating Oil analysis (for oil lubricated shafts), or
 - Fresh Water Sample test (for closed system fresh water lubricated shafts).
- Oil Sample Examination (for oil lubricated shafts), or Fresh Water Sample test (for closed system fresh water lubricated).
- Verification of no reported repairs by grinding or welding of shaft and/or propeller.
- Confirmation from the Chief Engineer that the shafting arrangement is in good working condition.

5.3.2 Extension Up to One (1) Year

The survey is to consist of:

- Visual Inspection of all accessible parts of the shafting system.
- Verification that the propeller is free of damages which may cause the propeller to be out of balance.
- Verification of the effectiveness of the inboard seal and outboard seals.
- Review of the previous wear and/or clearance recordings.
- Review of service records.
- Review of test records of:
 - Lubricating Oil analysis (for oil lubricated shafts), or
 - Fresh Water Sample test (for closed system fresh water lubricated shafts).
- Oil Sample Examination (for oil lubricated shafts), or Fresh Water Sample test (for closed system fresh water lubricated).
- Verification of no reported repairs by grinding or welding of shaft and/or propeller.
- Confirmation from the Chief Engineer that the shafting arrangement is in good working condition.

5.3.3 Extension Up to Three (3) Months

The survey is to consist of:

- Visual Inspection of all accessible parts of the shafting system.
- Verification of the effectiveness of the inboard seal.
- Review of the previous wear and/or clearance recordings.
- Review of service records.

- Review of test records of:
 - Lubricating Oil analysis (for oil lubricated shafts), or
 - Fresh Water Sample test (for closed system fresh water lubricated shafts).
- Oil Sample Examination (for oil lubricated shafts), or Fresh Water Sample test (for closed system fresh water lubricated).
- Verification of no reported repairs by grinding or welding of shaft and/or propeller.
- Confirmation from the Chief Engineer that the shafting arrangement is in good working condition.

7 Water Lubricated Shafts (Open Systems) (2016)

When the propeller is removed for any reason, the propeller hub is to be examined by a surface crack detection method after reinstallation.

7.1 Shaft Survey Methods

7.1.1 Method 4

The survey is to consist of:

- Drawing the shaft and examining the entire shaft (including liners, corrosion protection system and stress reducing features, where provided, inboard seal system and bearings).
- For keyed and keyless connections:
 - Removing the propeller to expose the forward end of the taper,
 - Performing a nondestructive examination (NDE) by a surface crack detection method all around the shaft in way of the forward portion of the taper section, including the keyway (if fitted). For shafts provided with liners, the NDE shall be extended to the after edge of the liner
- For flanged connection:
 - Whenever the coupling bolts of any type of flange-connected shaft are removed or the flange radius is made accessible in connection with overhaul, repairs, or when deemed necessary by the Surveyor, the coupling bolts and flange radius are to be examined by means of a surface crack detection method.
- Checking and recording the bearing clearances.
- Verification that the propeller is free of damages which may cause the propeller to be out of balance.
- Verification of the satisfactory conditions of inboard seal during re-installation of the shaft and propeller.

7.3 Shaft Extension Surveys – Extension Types

7.3.1 Extension Up to One (1) Year

The survey is to consist of:

- Visual Inspection of all accessible parts of the shafting system.
- Verification that the propeller is free of damages which may cause the propeller to be out of balance.
- Checking and recording the clearances of bearing.
- Verification of the effectiveness of the inboard seal.
- Review of the previous clearance recordings.

- Service records.
- Verification of no reported repairs by grinding or welding of shaft and/or propeller.
- Confirmation from the Chief Engineer that the shafting arrangement is in good working condition.

7.3.2 Extension Up to Three (3) Months

The survey is to consist of:

- Visual Inspection of all accessible parts of the shafting system.
- Verification that the propeller is free of damages which may cause the propeller to be out of balance.
- Verification of the effectiveness of the inboard seal.
- Review of the previous clearance recordings.
- Service records.
- Verification of no reported repairs by grinding or welding of shaft and/or propeller.
- Confirmation from the Chief Engineer that the shafting arrangement is in good working condition.

9 Vessels in Great Lakes Service (2005)

9.1 Tailshaft Survey

Where arrangements are such as to permit an effective nondestructive examination by a surface crack-detection method (such as magnetic particle or dye penetrant) all around the shaft in way of the forward portion of the taper section, including the end of keyway (if fitted), the shaft need not be drawn for examination in its entirety. Where arrangements of the flanged tailshaft permits effective examination of the flange fillet by a surface crack detection method, bearing wear-down measurement and shaft seal effectiveness (oil-lubricated bearings), the shaft need not be withdrawn. The flange coupling bolts are to be examined by means of a surface crack detection method whenever they are removed. The Controllable-Pitch propeller hub is to be tested under operating conditions for oil tightness.

PART

7

CHAPTER 5 Tailshaft Surveys

SECTION 2 Allowable Bearing Wear

1 Vessels for Unrestricted Service and in Rivers and Intracoastal Waterways Services

1.1 Water-Lubricated Bearing Other than Rubber

1.1.1 Machinery Amidships

1.1.1(a) Shaft Diameter is less than or equal to 230 mm (9 in.). The after bearing is to be rebushed when clearance has reached 6.4 mm (0.25 in.).

1.1.1(b) Shaft Diameter is greater than 230 mm (9 in.) but less than or equal to 305 mm (12 in.). The after bearing is to be rebushed when clearance has reached 8.0 mm (0.31 in.).

1.1.1(c) Shaft Diameter is greater than 305 mm (12 in.). The after bearing is to be rebushed when clearance has reached 9.5 mm (0.38 in.).

1.1.2 Machinery Aft

1.1.2(a) Shaft Diameter is less than or equal to 230 mm (9 in.). The after bearing is to be rebushed when clearance has reached 4.8 mm (0.19 in.).

1.1.2(b) Shaft Diameter is greater than 230 mm (9 in.) but less than or equal to 305 mm (12 in.). The after bearing is to be rebushed when clearance has reached 6.4 mm (0.25 in.).

1.1.2(c) Shaft Diameter is greater than 305 mm (12 in.). The after bearing is to be rebushed when clearance has reached 8.0 mm (0.31 in.).

1.3 Water-Lubricated Rubber Bearing

Water-lubricated rubber bearings are to be rebushed when any water groove is 50% of the original depth, or whenever the clearance exceeds the limits as given above for water-lubricated bearings other than rubber, whichever occurs first.

1.5 Oil-Lubricated Bearings

Oil-lubricated bearings are to be rebushed when the wear exceeds the manufacturer's recommendations.

3 Vessels in Great Lakes Service

3.1 Water-Lubricated Bearings Other than Rubber

The after bearing is to be rebushed when it is worn down to $\frac{5}{16}$ inch clearance in the case of shafts 9 inches or less in diameter, $\frac{3}{8}$ inch in clearance where the diameter is above 9 inches but not more than 12 inches, and $\frac{1}{2}$ inch clearance where the shaft exceeds 12 inches in diameter.

3.3 Rubber and Oil-Lubricated Bearings

See 7-5-2/1.3 and 7-5-2/1.5.

PART
7

CHAPTER 6 Machinery Surveys

CONTENTS

SECTION 1	General.....	152
1	Examination During Overhaul.....	152
3	Examination at Shorter Intervals.....	152
5	Preventative Maintenance Techniques.....	152
SECTION 2	Survey Requirements	153
1	Annual Surveys – Machinery	153
1.1	All Vessels.....	153
1.3	Tankers	159
1.5	Liquefied Gas Carriers.....	159
1.7	Gas Fueled Vessels other than Liquefied Gas Carriers	161
1.9	Vessels with Single or Dual Fuel Engines	162
3	Special Periodical Surveys – Machinery.....	163
3.1	All Vessels.....	163
3.3	Tankers	168
3.5	General Dry Cargo Vessels (ESDC)	169
3.7	Gas Fueled Vessels other than Liquefied Gas Carriers	169
3.9	Vessels with Single or Dual Fuel Engines	170
SECTION 3	Vessels in Great Lakes Service	171
1	Special Periodical/Continuous Surveys – Machinery – Year of Grace	171

PART

7

CHAPTER 6 Machinery Surveys

SECTION 1 General

1 Examination During Overhaul

On all occasions of overhaul or adjustment, access is to be provided for the Surveyor to examine the parts opened. In the event of defects being discovered, such other parts as may be considered necessary are to be opened and examined.

3 Examination at Shorter Intervals

If it is found desirable, upon examination, that any part of the machinery should be examined at shorter intervals than specified, it will be necessary for Owners to comply with the Committee's requirements in this respect.

5 Preventative Maintenance Techniques

Vessels which have an approved program of Preventative Maintenance will be given special consideration as to the details and intervals for examination of machinery. See Appendix 7-A-14 titled, "Survey Based on Preventative Maintenance Techniques."

CHAPTER 6 Machinery Surveys

SECTION 2 Survey Requirements

1 Annual Surveys – Machinery (*1 July 2012*)

(*1 July 2011*) The Chief Engineer (or other owner's representative) is to be reminded of the Owner's obligation to advise and submit to ABS any damage, failure, deterioration, or repairs which affect or may affect classification, and is to confirm that to the best of their knowledge the vessel has had no damages, failures, deteriorations, or repairs (including temporary repairs) to hull, machinery, or equipment since the last annual survey.

At each Annual Survey the machinery and electrical installations are to be generally examined so far as can be seen and placed in satisfactory condition. The survey is also to include the following items, as applicable:

1.1 All Vessels1.1.1 Machinery and Machinery Spaces (*2014*)

1.1.1(a) Machinery Spaces. Machinery and boiler spaces with particular attention to the propulsion system, auxiliary machinery (including all main and auxiliary piping systems, where accessible), fire and explosion hazards (particularly in way of tank top areas and bilges), risks to personnel from moving parts, hot surfaces and other hazards and confirmation that emergency escape routes are not blocked.

1.1.1(b) Dead Ship Starting Arrangement. Means to bring the machinery into operation, as required by SVR 4-8-2/3.1.3 and SVR 4-8-4/1.13, as applicable.

1.1.1(c) Protection Arrangements for Fuel Oil System (2005). Protection arrangements for external high-pressure fuel oil delivery lines, as required by SVR 4-6-5/3.3.7, and for fuel oil line joints, as required by SVR 4-6-4/13.3.3 and SVR 4-6-5/3.3.6, and insulation for hot surfaces with temperatures above 220°C, as required by SVR 4-2-1/11.9 and SVR 4-6-4/13.3.2.

1.1.1(d) Foundations (2006). The foundations of main and auxiliary machinery are to be generally examined.

1.1.2 Main Propulsion Gears

Main propulsion gear-tooth contact is to be examined at the time of the first Annual Survey after the vessel enters service, or after replacement gears have been placed in service. Examination for conventional gear units 1120 kW (1520 mhp, 1500 hp) and below and for all epicyclic gear units will be subject to special consideration. See SVR 4-3-1/9.9.

1.1.3 Steering Gear (*1 July 2011*)

All accessible parts of the steering arrangements, together with an operational test of the main and auxiliary steering gear, including their associated equipment, means of indicating angular position of the rudder, and control systems, performed while the vessel is not under way.

1.1.4 Anchor Windlass (*2004*)

All accessible parts of the anchor windlass.

1.1.5 Communication (1 July 2011)

Testing of all means of communication between the navigation bridge, the machinery control positions, and the steering gear space, as well as the alternative steering position, if fitted. Confirmation that there are means of relaying heading information and visual compass readings to the emergency steering position.

1.1.6 Bilge System (1 July 2011)

Bilge pumping system, bilge wells and oil pollution prevention equipment, including operation of pumps, remote reach rods and level alarms, where fitted. Examination of each bilge pump and confirmation of the bilge pumping arrangement for each watertight compartment. Examination of the functionality of bilge well alarms to all cargo holds and conveyor tunnels. For passenger vessels, operational test to include emergency bilge system.

1.1.7 Boilers, Pressure Vessels, Thermal Oil Heaters, and Fired Equipment (2011)

Boilers, pressure vessels, thermal oil heaters, fired equipment, and their external mountings, including safety devices, foundations, control, relieving gear, high-pressure and steam escape piping, insulation and gauges.

(2007) In addition, boilers are to be examined in accordance with 7-7-1/13.

1.1.8 Electrical Installation (2002)

1.1.8(a) Equipment. Electrical machinery, the emergency sources of electrical power, the switchgear, and other electrical equipment, including operation of same. Confirmation, as far as practicable, of the operation of the emergency sources of electrical power and, where appropriate, their automatic operation.

1.1.8(b) Cable Penetrations (1 July 2013). Watertight and fire-rated cable penetrations in decks and bulkheads to be generally examined for alterations and continued effectiveness.

1.1.8(c) Protection Against Shock. General examination of safety precautions against shock, fire and other hazards of electrical origin.

1.1.8(d) Schedule of Batteries (2008). Details of the schedule for storage, maintenance and replacement of batteries for essential and emergency services in the vessel's operational maintenance routine, as appropriate, is to be verified. See SVR 4-8-4/5.1.5 and 4-6-3/3.7.5 of the *ABS Rules for Building and Classing Steel Vessels Under 90 meters (295 feet) in Length*.

1.1.9 Fire Extinguishing

Fire-extinguishing apparatus required for Classification, including examination and/or testing of the following as applicable:

1.1.9(a) Fire Main System. Fire main system, including isolating valves and hydrants. Fire mains are to undergo satisfactory pressure testing at the working pressure.

1.1.9(b) Fire Pumps (2003). Fire pumps, including verification that each fire pump including the emergency fire pump can deliver two jets of water simultaneously from different hydrants. Self priming arrangements to be confirmed in satisfactorily maintained condition and to be operationally tested.

1.1.9(c) Fire Fighting Equipment. Verification that fire hoses, nozzles, applicators and spanners are in good working condition and situated at their respective locations.

1.1.9(d) Semi-Portable and Portable Fire Extinguishers. Verification that all semi-portable and portable fire extinguishers are in their stowed positions, checking for evidence of proper maintenance and servicing, conducting random check for evidence of discharged containers.

1.1.9(e) Fire Control Plans (1 July 2001). Confirmation that Fire Control Plans are properly posted.

1.1.9(f) International Shore Connection (1 July 2001). Confirmation that an international shore connection is provided.

1.1.9(g) Fixed Fire Fighting System (1 July 2015). Before commencing examination/testing of the system, measures to prevent accidental discharge are to be taken in accordance with manufacturer's recommendation and safe working practices. Examination of fixed fire-fighting system controls, piping, instructions and marking, checking for evidence of proper maintenance and servicing, including date of last systems tests; foam concentrates are to be tested at intervals recommended by the manufacturer and renewed if found unsatisfactory for further use. The manifold should be examined to verify that flexible discharge hoses and fittings are properly tightened. CO₂ system flexible hoses are to be visually examined.

1.1.9(h) Fire and Smoke Detection System (2005). Examination as far as possible and testing as feasible of the fixed fire and/or smoke detection and fire alarm system(s).

1.1.9(i) Remote Controls (1 July 2006). Verification, as far as practicable, that the remote controls for stopping fans and machinery and closing valves for fuel oil, lubricating oil and other flammable oils are in working order. For passenger vessels, examination and testing as far as possible of indication arrangements of the status of fans at control position.

1.1.9(j) Fireman's Outfits (2005). Verification that the fireman's outfits, including breathing apparatus, are complete and in satisfactory condition. For passenger vessels carrying more than 36 passengers, verification is to include water fog applicators, and also two-way portable radio telephone apparatus for fire patrols.

1.1.9(k) Closing Arrangements (1 July 2004). Examination of the closing arrangements of openings in funnels, skylights, ventilators, doorways and tunnels. Ventilator ducts are to be opened to verify satisfactory condition and operation of dampers. For passenger vessels, examination and testing as far as possible of control, alarm and indication arrangements of fire doors at control position.

1.1.9(l) Requirements by Flag Administration (1998). These requirements for fire-extinguishing apparatus are intended as minimum classification requirements and do not prevent more extensive requirements by the Flag Administration. Where the examinations and/or tests required are carried out by ABS on behalf of an Administration, or by a Flag Administration, their acceptance will be subject to a satisfactory general examination of the fire fighting equipment and a review of the relevant documentation.

1.1.9(m) Emergency Escape Breathing Devices (EEBD) (2005). Verification that EEBDs are in their stowed positions and in satisfactory condition.

1.1.9(n) Fire extinguishing systems (1 July 2006). Fire extinguishing systems for spaces containing paint and/or flammable liquids and deep-fat cooking equipment in accommodation and service spaces are to be examined.

1.1.9(o) Fire fighting systems (1 July 2006). Operational readiness and maintenance of fire fighting systems are to be verified.

1.1.10 Helicopter Operations (1 July 2006)

Where areas of the vessel are designated for helicopter operations, the following, where fitted, are to be examined.

- Ventilation and electrical equipment.
- Fire fighting appliances
- Refueling and hanger facilities including fuel storage system, tanks, pumps, piping, valves, vent, sounding, overflow, spill containment and remote shutdowns.
- Operations manual for helicopter facilities, including checklist of safety precautions and procedures, is to be verified.

1.1.11 Manually Operated Alarms (2005)

Examination and testing of manually operated alarms, including general emergency alarm, engineer's alarm, refrigerated space alarm, elevator's alarm and public address system, as applicable.

1.1.12 Inert Gas Systems (2004)

At each Annual Survey of Machinery the inert gas system is to be generally examined in so far as can be seen and placed in satisfactory condition. The survey is also to include the following, as applicable:

1.1.12(a) General

- i) *External Examination.* External examination of all components and piping, including scrubber, fans, valves, stand pipe and screens.
- ii) *Inert Gas Blower.* Confirmation of proper operation of inert gas blowers. In the gas generator type system with one inert gas blower and/or one fuel oil pump, sufficient spares for the blower and/or fuel oil pump and its prime mover are to be verified onboard.
- iii) *Air compressor.* Confirmation of proper operation of air compressors and feed air treatment system for nitrogen generator system. In the system with one air compressor, sufficient spares for the air compressor and its prime mover are to be verified onboard.
- iv) *Scrubber Room Ventilation System.* Observation of the operation of the scrubber room ventilation system.
- v) *Air compressor, nitrogen generator and nitrogen receiver/buffer tank room.* Observation of the operation of the ventilation system and low oxygen alarm system for the compartment
- vi) *Non-return device.* Deck seals or double block and bleed assemblies, and non-return valves are to be examined externally and proven to be in operation. Automatic filling and draining of the deck seal, operation of non-return valves and double block and bleed assemblies, and the water carryover are to be checked.
- vii) *Control Valves.* Verify the operation of all remotely operated or automatically controlled valves and, in particular, the flue gas isolating valves.
- viii) *Interlocking Feature.* Verify the operation of the interlocking feature of soot blowers.
- ix) *Gas Pressure Regulating Valve.* Verify the automatic operation of the gas pressure-regulating valve.
- x) *Operation and Maintenance Records.* The Surveyor is to examine the permanent records to verify the operation and maintenance of the system. Consideration may be given by the Surveyor for the crediting of certain items that have been properly documented and recorded.

1.1.12(b) *Alarm and Safety Device.* Verify the operation of the following alarms and safety devices using simulated conditions, where necessary:

- i) *Flue Gas Systems*
 - Low water pressure or low water flow rate to the flue gas scrubber, including automatic shut-down of the inert gas blowers and gas regulating valve.
 - High water level in the flue gas scrubber, including automatic shut-down of the inert gas blowers and gas regulating valve.
 - High gas temperature at IGS blower discharge, including automatic shut-down of the inert gas blowers and gas regulating valve.
 - Failure of the inert gas blowers, including automatic shut-down of the gas regulating valve.
 - Oxygen content in excess of 8% by volume.
 - Failure of the power supply to the automatic control system for the gas regulating valve and to the oxygen content and gas pressure indicating devices.
 - Low water level in the water seal.
 - Gas pressure less than 100 mm water gauge. (For combination carrier, the alarm arrangements are to ensure that the pressure in slop tanks can be monitored at all times.)

- Additional low gas pressure audible alarm system independent of alarm system for gas pressure less than 100 mm water gauge, if fitted.
- Automatic shutdown of cargo pumps to operate on predetermined limits of low pressure in the inert gas mains, if fitted.
- High gas pressure.
- Accuracy of fixed and portable oxygen measuring equipment by means of a calibration gas.

ii) *Inert Gas Generating Systems*

- Low water pressure or low water flow rate to the inert gas scrubber, including automatic shut-down of the inert gas blowers, gas regulating valve and fuel oil supply to the gas generator.
- High water level in the inert gas scrubber, including automatic shut-down of the inert gas blowers and gas regulating valve.
- High gas temperature at IGS blower discharge, including automatic shut-down of the inert gas blowers, gas regulating valve and fuel oil supply to the gas generator.
- Failure of the inert gas blowers, including automatic shut-down of the gas regulating valve.
- Oxygen content in excess of 8% by volume.
- Failure of the power supply to the automatic control system for the gas regulating valve and to the oxygen content and gas pressure indicating devices.
- Low water level in the water seal.
- Gas pressure less than 100 mm water gauge. (For combination carrier, the alarm arrangements are to ensure that the pressure in slop tanks can be monitored at all times.)
- Additional low gas pressure audible alarm system independent of alarm system for gas pressure less than 100mm water gauge, if fitted.
- Automatic shutdown of cargo pumps to operate on predetermined limits of low pressure in the inert gas mains, if fitted.
- High gas pressure.
- Insufficient fuel oil supply.
- Failure of the power supply to the generator, including automatic shut-down of the gas regulating valve.
- Failure of the power supply to automatic control system for the generator.
- Accuracy of fixed and portable oxygen measuring equipment by means of a calibration gas.

iii) *Nitrogen Generating Systems*

- Low air pressure, including automatic shut-down of the system.
- High air temperature, including automatic shut-down of the system.
- High condensate level at automatic drain of water separator, including automatic shut-down of the system.
- High gas temperature, including automatic shut-down of the gas regulating valve.
- Failure of electrical heater, if fitted, including automatic shut-down of the system.

- Failure of nitrogen gas pressure, including automatic shut-down of the gas regulating valve.
- Oxygen content in excess of 5% by volume, including automatic shut-down of the system.
- Failure of the power supply to the automatic control system for the gas regulating valve and to the oxygen content and gas pressure indicating devices.
- Gas pressure less than 100 mm water gauge. (For combination carrier, the alarm arrangements are to ensure that the pressure in slop tanks can be monitored at all times.)
- Additional low gas pressure audible alarm system independent of alarm system for gas pressure less than 100 mm water gauge, if fitted.
- Automatic shutdown of cargo pumps to operate on predetermined limits of low pressure in the nitrogen gas mains, if fitted.
- High gas pressure.
- Accuracy of fixed and portable oxygen measuring equipment by means of a calibration gas.

1.1.13 Annual Confirmation Survey of Preventative Maintenance Program (2005)

The effectiveness of the preventative maintenance program is to be confirmed (see 7-A-14/15).

1.1.14 Dangerous Goods (2004)

Additional features fitted in accordance with the requirements for vessels intended to carry dangerous goods per 4-7-2/7.3 are to be examined, tested, as applicable, and placed in satisfactory condition. Generally, additional requirements are applicable to:

- Water supplies
- Sources of ignition
- Detection system
- Ventilation
- Bilge pumping
- Personnel protection
- Portable fire extinguishers
- Insulation of machinery space boundaries
- Water spray systems
- Separation of ro-ro spaces

1.1.15 Watertight Bulkhead Doors (2005)

Examination and testing as far as possible of control, alarm and indication arrangements of watertight doors at control positions.

1.1.16 Propulsion Thrusters (2007)

In addition to the applicable requirements of this section, propulsion thrusters are to be surveyed in accordance with the applicable requirements of 7-9-6/1.1.

1.1.17 Gaseous Fuel for Domestic Services (1 July 2011)

Examination of the arrangements for the storage, distribution, and utilization of gaseous fuel used for domestic purposes.

1.1.18 Expansion Joints (1 July 2011)

Expansion joints in the seawater systems are to be visually examined.

1.3 Tankers (2001)

In addition to the applicable requirements of 7-6-2/1.1, the Annual Survey is also to include the following:

1.3.1 Steering Machinery

Operation of the arrangements to regain steering capability in the event of a single failure.

1.3.2 Fixed Fire Fighting System

An external examination of piping and cutout valves of cargo tank and cargo pump room fixed fire-fighting systems.

1.3.3 Deck Foam System

Confirmation that the deck foam system is in operating condition.

1.3.4 Bow or Stern Loading and Unloading (2002)

An examination of loading/unloading piping, including welded joints, identification, means of segregation from the cargo main line, closing arrangement of the loading/unloading connection, draining and leak detection arrangements and spill containment. Means of communications between the cargo control room and the loading/unloading connection to be tested.

1.3.5 Gas Detection (1 July 2006)

i) An examination of portable gas detectors and oxygen analyzers.

ii) An examination and test of the Double Hull Space fixed or portable gas detection system.

1.3.6 Cargo Pump Room Protection (1 July 2006)

An examination and test of the following systems, as applicable.

i) Temperature sensing devices and alarms for bulkhead shaft glands, bearings and pump casings of cargo pumps, ballast pumps and stripping pumps installed in the cargo pump rooms and driven by shafts passing through pump room bulkheads.

ii) Interlock between lighting and ventilation system

iii) Fixed gas detection and alarm system

iv) Bilge level monitoring and alarm system

v) Emergency lighting system

1.3.7 Liquefied Gas Carriers

See additional requirements in 7-3-2/1.13.8.

1.3.8 Chemical Carriers

See additional requirements in 7-3-2/1.13.7.

1.5 Liquefied Gas Carriers (1 July 2013)

1.5.1 General

The following is to be carried out during the survey of the Boil-Off Gas (BOG) Utilization System:

i) *General.* The logbooks are to be examined with regard to correct functioning of the BOG systems. The hours per day of the re-liquefaction plants or the boil-off rate are to be considered.

ii) *Operating and Maintenance Instruction Manual (2016).* The manufacturer/builder instructions and manuals covering the operations, safety and maintenance requirements and occupational health hazards relevant to the BOG utilization units and use of gas as fuel, are to be confirmed as being aboard the vessel.

- iii) *Instrumentation and Safety Systems.* Gas detection equipment in all compartments containing BOG utilization equipment or components, including indicators and alarms, is to be confirmed in satisfactory operating conditions. Verification of installed interlocks in the gas detection system is to be verified in working condition. Any piping of the gas detection system is to be visually examined for corrosion and damage and the integrity of the line between suction points and analyzing units is to be confirmed as far as possible. Recalibration of the gas detection systems should be verified in accordance with the manufacturers' recommendations.
- iv) *BOG Handling Piping and Machinery.* All piping, hoses, emergency shut-down valves, remote operating valves, machinery and equipment for BOG utilization such as venting, compressing, refrigerating, liquefying, heating, cooling or otherwise handling the liquefied gas or vapor is to be examined, as far as possible. Stopping of pumps and compressors upon emergency shut-down of the system is to be confirmed.
- v) *Ventilating System.* Examination of the ventilation system is to be made for all spaces containing BOG utilization units or components, including air locks, pump rooms, compressor rooms, gas valve rooms, control rooms and spaces containing gas burning equipment. All required portable ventilating equipment is to be examined. Provision of spares for mechanical ventilation fans recommended by manufacturer is to be confirmed. Where alarms, such as differential pressure and loss of pressure alarms, are fitted, these should be operationally tested as far as practicable.
- vi) *Drip Trays.* Portable and fixed drip trays and insulation for the protection of the deck in the event of gas leakage are to be examined
- vii) *Sealing Arrangements.* Sealing arrangements in way of openings and bulkhead penetrations for the BOG system are to be examined
- viii) *Fire Protection and Fire Extinguishing Equipment.* The required fire protection and fire extinguishing system contained in areas and spaces where BOG utilization units are fitted are to be examined and operationally tested, in so far as practicable.
- ix) *Electrical Equipment.* Electrical equipment in gas-dangerous spaces or zones is to be examined for continued suitability for their intended service and installation area.
- x) *Electrical Bonding.* Electrical bonding arrangements, including bonding straps where fitted, of the piping systems for BOG utilization systems located within cargo tanks, ballast tanks, pipe tunnels, cofferdams and void spaces bounding cargo tanks are to be examined.

1.5.2 Gas Combustion Unit

The following are to be examined, so far as applicable:

- i) The Gas Burning Unit during working condition.
- ii) External examination of all pressure vessels in the system.
- iii) Testing of burner management control system, and flame scanner and installed interlocks.
- iv) External examination of the combustion chamber and associated refractory
- v) External examination of exhaust gas piping/ducts.
- vi) Testing of the remote and local closing of the installed "master gas valve" and automatic gas shut-off valve for each Gas Combustion Unit compartment

1.5.3 Re-Liquefaction Plant

The following are to be examined, so far as applicable. Insulation need not be removed, but any deterioration or evidence of dampness is to be investigated:

- i) The plant during working condition.
- ii) External examination of all pressure vessels in the system
- iii) External examination of relief valves, if fitted.
- iv) The re-liquefaction/refrigeration plant spare gears as recommended by the manufacturer.

- v) Testing of control, monitoring and shut-down systems as far as practicable, or verification of set-points in accordance with approved test program
- vi) Examination and testing of installed bilge alarms and means of drainage of the compartment.

1.7 Gas Fueled Vessels other than Liquefied Gas Carriers (1 July 2013)

1.7.1 General

The following is to be carried out during the survey of the Gas Fuel Storage, Fuel Bunkering System, Fuel Gas Supply System and Gas Utilization Systems:

- i) *General.* The logbooks are to be examined with regard to correct functioning of the fuel gas detection systems, fuel gas supply/gas systems, etc. The hours per day of the prime movers, re-liquefaction plant, Gas Combustion Unit, as applicable, or the boil-off rate are to be considered together with historical gas detection records.
- ii) *Operating and Maintenance Instruction Manual (2016).* The manufacturer/builder instructions and manuals covering the operations, safety and maintenance requirements and occupational health hazards relevant to gas fuel storage, fuel bunkering, fuel gas supply, gas utilization units and associated systems and use of gas as fuel, are to be confirmed as being aboard the vessel.
- iii) *Instrumentation and Safety Systems.* Gas detection equipment in all compartments containing gas fuel storage, fuel bunkering, fuel gas supply or gas utilization equipment or components or associated systems, including indicators and alarms, is to be confirmed in satisfactory operating conditions. Verification of installed interlocks in the gas detection system is to be verified in working condition. Any piping of the gas detection system is to be visually examined for corrosion and damage and the integrity of the line between suction points and analyzing units is to be confirmed as far as possible. Recalibration of the gas detection systems should be verified in accordance with the manufacturers' recommendations.
- iv) *Fuel Gas Handling Piping and Machinery.* All piping, hoses, emergency shut-down valves, remote operating valves, machinery and equipment for gas fuel storage, fuel bunkering, fuel gas supply and gas utilization such as venting, compressing, refrigerating, liquefying, heating, cooling or otherwise handling the liquefied gas or vapor is to be examined, as far as possible. Stopping of pumps and compressors upon emergency shut-down of the system is to be confirmed.
- v) *Ventilating System.* Examination of the ventilation system is to be made for all spaces containing gas fuel storage, fuel bunkering, fuel gas supply and gas utilization units or components or associated systems, including air locks, pump rooms, compressor rooms, fuel preparation rooms, gas valve rooms, control rooms and spaces containing gas burning equipment. All required portable ventilating equipment is to be examined. Provision of spares for mechanical ventilation fans recommended by manufacturer is to be confirmed. Where alarms, such as differential pressure and loss of pressure alarms, are fitted, these should be operationally tested as far as practicable.
- vi) *Drip Trays.* Portable and fixed drip trays and insulation for the protection of the deck in the event of gas leakage are to be examined
- vii) *Sealing Arrangements.* Sealing arrangements in way of openings and bulkhead penetrations for the gas fuel system are to be examined
- viii) *Fire Protection and Fire Extinguishing Equipment.* The required fire protection and fire extinguishing system contained in areas and spaces where gas fuel storage, fuel bunkering, fuel gas supply and gas utilization units are fitted are to be examined and operationally tested, in so far as practicable.
- ix) *Electrical Equipment.* Electrical equipment in gas-dangerous spaces or zones is to be examined for continued suitability for their intended service and installation area.
- x) *Electrical Bonding.* Electrical bonding arrangements, including bonding straps where fitted, of the piping systems for gas utilization systems located within bunker tanks, ballast tanks, pipe tunnels, cofferdams and void spaces bounding bunker tanks are to be examined.

1.7.2 Gas Storage, Bunkering and Supply Systems

The following are to be examined, so far as applicable. Insulation need not be removed, but any deterioration or evidence of dampness is to be investigated:

1.7.2(a) Gas Fuel Storage

- i) External examination of the bunker tanks and secondary barrier or gas fuel storage room.
- ii) External examination of main tank and relief valves.
- iii) Testing of tank monitoring system.
- iv) Examination and testing of installed bilge alarms and means of drainage of the compartment.
- v) Testing of the remote and local closing of the installed Main Tank Valve.

1.7.2(b) Fuel Bunkering System

- i) Examination of all bunker stations and the fuel bunkering system during working condition.
- ii) External examination of bunker manifolds.
- iii) External examination of manifold valves and manifold ESD valves.
- iv) Testing of fuel bunkering control, monitoring and shut-down systems as far as practicable, or verification of set-points in accordance with approved test program.
- v) Testing of bunker lines inert and gas freeing system.

1.7.2(c) Fuel Gas Supply System

- i) The fuel gas supply system during working condition.
- ii) External examination of all pressure vessels, heat exchangers, pumps, compressors, filters etc. for making-up the gas for its use as fuel in the system.
- iii) External examination of relief valves, if fitted.
- iv) Location of applicable warning notices.
- v) Where double wall fuel gas piping is provided, means for detecting any leakage should be tested.
- vi) The fuel gas supply system component spares as recommended by the manufacturer.
- vii) Testing of control, monitoring and shut-down systems as far as practicable, or verification of set-points in accordance with approved test program.

1.9 Vessels with Single or Dual Fuel Engines (1 July 2013)

1.9.1 Dual Fuel Diesel Engine Power Plant

In addition to the Annual Survey requirements for liquid fuel diesel engines, the following are to be examined, so far as applicable. Insulation need not be removed, but any deterioration or evidence of dampness is to be investigated:

- i) External examination of any pressure vessels, heat exchangers, compressors, filters etc. for making-up the gas for its use as fuel.
- ii) Operational test, as far as practicable of the power management system for the emergency shutdown of the dual fuel engine compartments and testing of the automatic shut-off of gas fuel supply.
- iii) Where double wall fuel gas piping is provided, means for detecting any leakage should be tested.
- iv) Verification of redundancy and testing of gas detection system in engine rooms together with any interlocks.
- v) Testing of alarm for the access doors to the engine rooms.
- vi) Testing of the remote and local closing of the installed main tank valve and master gas valve for each engine compartment.

1.9.2 Single Gas Fuel Engine Power Plant

In addition to the Annual Survey requirements for liquid fuel diesel engines, the following are to be examined, so far as applicable. Insulation need not be removed, but any deterioration or evidence of dampness is to be investigated:

- i) External examination of any pressure vessels, heat exchangers, compressors, filters etc. for making-up the gas for its use as fuel.
- ii) Operational test, as far as practicable of the power management system for the emergency shutdown of the single fuel engine compartments and testing of the automatic shut-off of gas fuel supply.
- iii) Where double wall fuel gas piping is provided, means for detecting any leakage should be tested.
- iv) Verification of redundancy and testing of gas detection system in engine rooms together with any interlocks.
- v) Testing of alarm for the access doors to the engine rooms.
- vi) Testing of the remote and local closing of the installed main tank valve and master gas valve for each engine compartment.

1.9.3 Dual Fuel Gas Turbine Power Plant

The attending Surveyor is to examine, as far as applicable, the following:

- i) Verify compliance with the approved maintenance schedule and manufacturers' recommendations, taking into consideration the "in-service" records for the unit and applicable hours of running time for each type of fuel.
- ii) Structural examination of the gas turbine enclosure and foundation.
- iii) Verify satisfactory operation of any fitted interlocks on the gas enclosure.
- iv) Verify air-tightness of the gas turbine enclosure or its capability of maintaining a negative pressure inside the enclosure by means of testing of installed alarms if fitted.
- v) Examination and testing of installed gas turbine enclosure ventilation and associated alarms.
- vi) External examination of gas turbine enclosure air intakes, combustion air intake and exhaust system and fitted dampers.
- vii) Testing of the remote and local closing of the installed Main Tank Valve and Master Gas Valve for each dual fuel gas turbine.
- viii) Testing of the control system for the gas turbine and associated alarms, changeover and shutdown functions.

3 Special Periodical Surveys – Machinery

3.1 All Vessels

At each Special Periodical Survey, the following items are to be examined and placed in satisfactory condition:

3.1.1 General

3.1.1(a) Openings to the Sea (2003). All openings to the sea, including sanitary and other overboard discharges, together with the valves connected therewith, are to be examined internally and externally while the vessel is in dry dock and the fastenings to the shell plating are to be renewed when deemed necessary by the Surveyor. The emergency fire pump non-return valve (if fitted) is to be examined internally and externally.

3.1.1(b) Pumps and Pumping Arrangements. Pumps and pumping arrangements, including valves, cocks, pipes and strainers, are to be examined. Nonmetallic flexible expansion pieces in the main circulating system are to be examined. The Surveyor is to be satisfied with the operation of the bilge system. Other systems are to be tested, as considered necessary.

3.1.1(c) Shafts. Shafts (except the propeller shaft), thrust bearings and lineshaft bearings are to be opened for examination.

3.1.1(d) Foundations. The foundations of main and auxiliary machinery are to be examined.

3.1.1(e) Heat Exchangers and Unfired Pressure Vessels. Heat exchangers and other unfired pressure vessels with design pressures over 6.9 bar (7 kgf/cm², 100 psi) are to be examined, opened out and pressure tested, as deemed necessary, and associated relief valves proven operable. Evaporators that operate with a vacuum on the shell need not be opened, but may be accepted on basis of satisfactory external examination and operational test or review of operating records.

3.1.1(f) Compressed Air System (2001). Air compressors, air reservoirs and associated piping are to be examined. If air reservoirs cannot be examined internally, they are to be hydrostatically tested. All relief valves and safety devices are to be proven operable.

3.1.1(g) Steering Machinery. Examination of the steering machinery is to be carried out, including an operational test and checking of relief-valve settings. Further, a hydrostatic check of the steering system to the relief valve setting is to be conducted using the installed power units. The machinery may be required to be opened for further examination, as deemed necessary by the Surveyor.

3.1.1(h) Main Propulsion Gears. Reduction gearing is to be opened and examined as deemed necessary by the Surveyor in order to confirm the condition of the gears, pinions, shafts, bearings and lubrication system. Alternative means of ascertaining the condition of epicyclic gearing will be specially considered.

3.1.1(i) Anchor Windlass. Examination of anchor windlass, including an operational check, check of the brake and testing of safety devices.

3.1.1(j) Steam Reciprocating Engine. Steam reciprocating engines are to be opened and examined, including cylinders, pistons, valves, valve gear, crossheads, crankpins, main journals and thrust bearing.

3.1.1(k) Steam Condenser. Main and auxiliary steam condensers are to be opened, examined and leak tested, as deemed necessary by the Surveyor.

3.1.1(l) Steam Piping. Steam piping is to be examined, and where deemed necessary by the Surveyor, sections may be required to be removed for examination. Where deemed necessary by the Surveyor, the thickness is to be ascertained by nondestructive means. Alternatively, for installations operating at temperatures not exceeding 427°C (800°F) hydrostatic tests to 1.25 times the working pressure may be accepted. Copper pipes are to be annealed before the test. Where deemed necessary by the Surveyor, the thickness is to be ascertained to determine the future working pressure.

3.1.1(m) (2007) (No text)

3.1.1(n) Operational Testing. For Operational Testing of main and auxiliary machinery, see the following sections, as applicable:

7-8-2	Shipboard Automatic and Remote Control Systems
7-6-2/3.1.3(a)iii	Generators
7-6-2/3.1.3(c)	Major Repairs of Electrical Equipment
7-6-2/3.1.4	Steam Turbines
7-6-2/3.1.5	Gas Turbines

(1 July 2006) At the time of drydocking, a dock trial is to be carried out to the satisfaction of the Surveyor to confirm satisfactory operation of main and auxiliary machinery. If significant repairs are carried out to main or auxiliary machinery or steering gear, consideration should be given to a sea trial to the satisfaction of the Surveyor.

3.1.1(o) *Inert Gas Systems*. In conjunction with the Special Periodical Survey – Machinery, the following items of the Inert Gas System are to be examined and placed in satisfactory condition:

- i) *General*. All valves, including valves at boiler uptakes, air seal valves at uptakes, scrubber isolating valves, fans inlet and outlet isolating valves, main isolating valve, re-circulating valve (if fitted), pressure/vacuum breaker and cargo tank isolating valves are to be examined.
- Scrubber is to be examined.
 - Fans (blowers), including casing drain valves are to be examined.
 - Fan (blower) drives, either electric motor or steam turbine are to be examined.
 - Bellows expansions pieces are to be examined.
 - Sea water pumps, valves and strainers for scrubbers and water seals together with piping connections at the scrubber, water seals, shell plating and the remainder of the sea water piping are to be examined.
 - Stand pipe, where fitted, for purging in each cargo tank is to be examined.
 - Deck seals or double block and bleed assemblies, and non-return valves are to be examined externally and internally.
- ii) *Separate Inert Gas Generator System*. Surveys for separate inert gas generator systems are to comply with all applicable requirements for Special Periodical Surveys given in this section of the Rules, together with the following:
- Automatic combustion control system is to be examined and tested, as necessary.
 - Combustion chamber and mountings are to be examined internally and externally.
 - Forced draft fan is to be examined.
 - Fuel oil service pumps are to be examined.
- iii) *Gas Stored in Bottles System*. Systems using inert gas stored in bottles are to comply with all applicable requirements for Special Periodical Surveys given in this section of the Rules, together with the following:
- Bottles are to be examined internally and externally. If they cannot be examined internally, they are to be thickness measured. When considered necessary by the Surveyor, they are to be hydrostatically tested. Relief valves are to be proven operable.
 - Where an alkali (or other) scrubber is fitted in the system, the scrubber, circulating pump, valves and piping are to be examined internally and externally.

3.1.1(p) *Thermal Fluid Heaters (2004)*. Thermal fluid heaters are to be opened out, examined and pressure tested, as deemed necessary. Associated relief valves are to be proven operable.

3.1.1(q) *Propulsion Thrusters (2007)*. In addition to the applicable requirements of this section, propulsion thrusters are to be surveyed in accordance with the applicable requirements of 7-9-6/1.3.

3.1.1(r) *Oil Pollution Prevention Equipment (2005)*. Oily water filtering or separating equipment, including pumps, piping, fittings, control and alarm devices, is to be opened, examined and tested, as deemed necessary. Oil content meter, where fitted, is to be examined and confirmed in satisfactory working order, including calibration status, if applicable.

3.1.1(s) *Arrangements for Oxygen-Acetylene Systems (2008)*. Storage and distribution systems are to be examined as accessible including piping systems, pressure relief devices, ventilation and electrical equipment as installed in the applicable spaces. Where deemed necessary by the Surveyor, pressure test and/or leak test with nitrogen or a suitable inert gas may be required.

3.1.1(t) *Fixed Gas and Foam Extinguishing Systems (2017)*. The discharge piping and nozzles shall be tested to verify that they are not blocked. The test shall be performed by isolating the discharge piping from the system and flowing dry air or nitrogen from test cylinders, or other suitable means as recommended by manufacturer, though the piping to confirm the pipework and nozzles are clear of any debris and obstructions. This may require the removal of nozzles, if applicable.

3.1.1(u) *Fixed Water Spray and Mist Systems (2017)*. The nozzles and pipes shall be checked to confirm that they are free of obstructions, by blowing through the lines with compressed air or water as applicable or other suitable means recommended by the manufacturer. Nozzles should be removed for this test.

3.1.2 Internal Combustion Engines

3.1.2(a) *Main and Auxiliary Internal Combustion Engines (2016)*. Main and auxiliary internal combustion engines are to be opened and examined, including cylinders, cylinder heads, valves and valve gear, fuel pumps, scavenging pumps, and superchargers, pistons, crossheads, connecting rods, crankshafts, clutch, reversing gear, air compressors, intercoolers and such other parts of the main and auxiliary machinery as are considered necessary. Tie rods are to be re-tensioned, as necessary. Engine entablature bolting is to be checked for tightness, and crankshaft deflections of medium/low-speed-type engines, as defined in 4-2-1/1.3 of the *Steel Vessel Rules* are to be recorded. Parts which have been examined within fifteen months need not be examined again, except in special circumstances. Special consideration as to the requirements for Special Periodical Surveys may be given for main engines with bores 300 mm (11.8 inches) or under, provided the engine is maintained under a manufacturer's scheduled maintenance program. The records of the program, including lubrication servicing, are to be made available to the Surveyor. Periodical overhauls, required by the manufacturer's scheduled maintenance program, are to be witnessed by the Surveyor and will be accepted for completion of the cycle.

3.1.2(b) *Fuel Oil System*. Essential components of the engine fuel oil system, including fuel oil service pumps, separators and heaters are to be examined.

3.1.3 Electrical Equipment

The entire electrical installation, including the following items, is to be examined and placed in satisfactory condition.

3.1.3(a) *Auxiliary Apparatus*

- i) *Main Switchboards and Distribution Panels*. Fittings and connections on main switchboards and distribution panels are to be examined, and care is to be taken to see that no circuits are overfused.
- ii) *Cables*. Cables are to be examined as far as practicable without undue disturbance of fixtures.
- iii) *Generators*. All generators, including emergency generator, are to be run under load. Where the generators are arranged to operate in parallel, satisfactory load sharing and operation of the circuit breakers, including the reverse power trip, are to be demonstrated.
- iv) *Equipment and Circuits*. All equipment and circuits are to be examined for possible development of physical changes or deterioration. The insulation resistance of the circuits is to be measured between conductors and between conductors and earth and these values compared with those previously measured. Any large and abrupt decrease in insulation resistance is to be further investigated and corrected.
- v) *Electrical Auxiliaries*. Where electrical auxiliaries are used for vital purposes, the generators and motors are to be examined and their prime movers opened for examination. The insulation resistance of each generator and motor is to be measured with all circuits of different voltages above earth being tested separately. This test is to be made with direct current potential to earth, as follows:
 - 500 volts DC for units 550 volts AC (phase to phase) or lower and also for DC fields.
 - 1000 volts DC for units 551 volts AC (phase to phase) up to 4000 volts AC.
 - 2500 volts DC for units 4001 volts AC (phase to phase) and up.

The direct current potential is to be applied for at least 30 seconds and the minimum insulation resistance is to be of the order of one-half to one megohm.

3.1.3(b) *Main Propulsion Apparatus.*

- i) *Generators and Motors.* The windings of generators and motors are to be thoroughly examined and found or made dry and clean. Particular attention is to be paid to the ends of all windings of stators and rotors.
- ii) *Ventilation.* All air ducts in stator coils and the ventilating holes in rotors and retaining rings of alternators are to be carefully examined and found or made clear and clean.
- iii) *Cable Runs.* All cable runs are to be examined and found or placed in good condition as to supports, etc., and the ground connections of protective coverings or sheath found substantial and effective. Particular attention is also to be paid to high-potential bus insulators, which are to be free from dust or oil in order to prevent creepage to ground.
- iv) *Insulation Resistance.* The insulation resistance of each propulsion unit is to be measured and found equal to the requirements noted above for auxiliary generators and motors. In order to further evaluate these insulation-resistance readings, it is recommended that a separate log be kept of insulation-resistance measurements taken frequently at regularly scheduled intervals. Humidity, ambient temperature and condition of the machine are also to be noted. Any large and abrupt decrease in insulation resistance, when compared with those recorded in the log, is to be investigated and corrected.
- v) *Insulation Resistance Log.* Alternately, a log of insulation resistance values is to be made at the beginning of the survey and insulation resistance is to be measured again at the end of the survey; a comparison is to be made between the measured value and the log made at the beginning of the survey. Any large or abrupt decrease in insulation resistance is to be further investigated and corrected.

3.1.3(c) *Major Repairs to Rotating Machines of 100 kW and Over for Essential Services.* On the occasion of major repairs, the coils repaired or renewed are to be subjected to a dielectric strain test, as specified under the applicable parts of SVR 4-8-3/3.15. In addition, the circuits containing the repairs or renewals and coils which have been disturbed during repairs are to be subjected to dielectric strain tests for one minute by application of a potential of 125% of the maximum operating voltage of the circuits to which it is applied. The DC fields of generators and motors are to be subjected for one minute to a test potential equal to 50% of the value specified under the applicable parts of SVR 4-8-3/3.15, and the whole apparatus operated under full-load conditions.

3.1.4 Steam Turbines

Main and auxiliary turbines are to be opened and examined, including nozzles, rotor with blading and shrouding, bearings, stationary blading, interstage packing, gland seals with oil barriers, bleed controls and foundation expansion arrangements. Throttle valves are to be operationally tested and opened, as deemed necessary.

(1998) At Special Periodical Survey No. 1, lifting of the main propulsion turbine casing may be waived, provided the turbines are fitted with rotor position indicators and vibration indicators of an approved type, as well as steam pressure measuring equipment at appropriate locations in the steam flow path. Rotor bearings, thrust bearings and the flexible coupling are to be opened and examined. The low pressure turbine exhaust trunk is to be opened for examination of the last row of low pressure and astern wheels. Turbine operating records are to be reviewed. The arrangements for change over in case of emergency operation of the plant are to be readily available. The turbines are to be operationally tested.

(1998) Turbine casings are to be lifted at Special Periodical Survey No. 2 and subsequent Special Periodical Surveys. However, provided an approved preventative maintenance arrangement has been established, including vibration monitoring, lubricating oil analysis and rotor position checks; provided the rotor journal bearings, thrust bearings and flexible couplings are opened up for examination, the low-pressure turbine exhaust trunk is opened for examination of the last row of low pressure and astern wheels, and provided the turbine operating records are reviewed and all considered satisfactory by the Surveyor, the lifting of main propulsion turbine casings may be waived at Special Periodical Survey No. 3 and alternate, subsequent Special Periodical Surveys. The turbines are to be operationally tested.

3.1.5 Gas Turbines

Gas turbines are to be opened and maintained in accordance with manufacturer's recommendations, as appropriate for the actual applicable operating conditions. Owners are to submit for approval maintenance schedules for each type of gas turbine in service, specifying proposed intervals for combustion checks, hot-gas-path examinations and major examinations. Upon approval, the schedules will become part of the Special Periodical Survey – Machinery records.

For units in continuous service, at least one hot-gas-path examination is to be scheduled each survey cycle and is to include an examination of turbine rotors, fixed blading, combustors, inlet casings (including demisters and filters), exhaust casing (including regenerator), air control valves and protective apparatus. Other parts and associated equipment, as may be deemed necessary by the attending Surveyor, are to be opened up for examination. Opening of compressor sections is to be scheduled in conjunction with major examinations, provided that examination of the blades visible from the inlet plenum during the hot-gas-path examination reveals no evidence of defects. The required examinations of auxiliary gas turbine units, at least once each cycle, are to be based on manufacturer's recommendations, as appropriate for the actual operating hours and conditions, together with an operation test including protective apparatus. Where units are arranged such that the unit is removed from the vessel and dismantled at another facility, the internal examination may be carried out at the facility. The reinstallation is to be carried out to the satisfaction of the Surveyor.

Upon reassembly/reinstallation, all fuel lines, lube oil piping, the unit itself and exhaust system are to be checked under full speed operational conditions for leakage. All shielding and fuel oil double wall piping is to be examined.

3.3 Tankers

3.3.1 Cargo Handling Systems

On tankers, an examination is to be made of cargo handling systems, including cargo pumps and drives, cargo piping, vent piping, valves and equipment. All remotely operated valves in the cargo piping system are to be examined and tested. See also 7-3-2/5.13.3 and 7-3-2/5.14.3. For independent cargo tanks, see 7-3-2/5.1.12.

3.3.2 Cargo Piping on Deck (2001)

Cargo piping on deck, including Crude Oil Washing (COW) piping, and all piping systems within all cargo tanks, salt water ballast tanks, combined cargo/salt water ballast tanks (including double bottom tanks), pump rooms, pipe tunnels, cofferdams and voids spaces bounding cargo tanks, decks and outer hull are to be examined and operationally tested under working pressure to attending Surveyor's satisfaction to ensure that tightness and condition remain satisfactory. Special attention is to be given to ballast piping in cargo tanks and any cargo piping in ballast tanks and void spaces. Surveyors are to be advised on all occasions when this piping, including valves and fittings, is open during repair periods and can be examined internally.

3.3.3 Liquefied Gas Carriers (1 July 2013)

In addition to the applicable requirements of 7-3-2/5.11 and 7-6-2/1.5, the Special Periodical Survey is also to include the following:

- i) *Boil-Off Gas (BOG) Handling and Piping Material.* All piping, machinery and equipment for BOG utilization, such as venting, compressing, refrigerating, liquefying, heating storing, burning or otherwise handling the liquefied gas or vapor and liquid nitrogen installations are to be examined including removal of insulation and opening for examination, as deemed necessary. Where deemed suspect, a hydrostatic test to 1.25 times the Maximum Allowable Relief Valve Setting (MARVS) for the pipeline is to be carried out. After reassembly, the complete piping is to be tested for leaks. Where water cannot be tolerated and the piping cannot be dried prior to putting the system into service, the Surveyor may accept alternative testing fluids or alternative means of testing.
- ii) *BOG Utilization Valves.* All emergency shut-down valves, check valves, block and bleed valves, master gas valves, remote operating valves in the BOG utilization piping systems are to be inspected and proven operable. The pressure relief valves are to be function-tested. A random selection of valves is to be opened for examination and adjusted as necessary.

- iii) *Pressure Vessels.* Internal examination and thickness measurement of the fitted pressure vessels in the BOG utilization units as deemed necessary by the Surveyor.
- iv) *Electrical Equipment.* Examination and testing of electrical equipment. This examination is to include the physical condition of electrical cables and supports, intrinsically safe, explosion proof, or increased safety features of electrical equipment, functional testing of pressurized equipment and associated alarms, testing systems for de-energizing electrical equipment which is not certified for use in gas-hazardous areas, and insulation resistance readings of circuits. Where a proper record of testing is maintained, consideration may be given to accepting recent readings.
- v) *Gas Combustion Unit.* Internal examination of the gas combustion unit, combustion chamber and associated refractory.

3.3.4 Chemical Carriers

3.3.4(a) Chemical Carriers ESP

- i) *Cargo Pump Rooms.* Examine for leakage and drainage arrangements, including operational test of the bilge system.
- ii) *Cargo Transfer and Control System.* Examine cargo transfer system including operational test of remote shut-down devices and remote operating valves, as fitted. Verify that the cargo hoses are compatible with the cargo carried, and suitable for the cargo temperature and working pressures.
- iii) *Temperature Control.* The cargo heating or cooling systems, as required, are to be examined including temperature indicating devices and alarm systems.
- iv) *Electrical Equipment.* Electrical equipment in hazardous locations, spaces or zones is to be examined.
- v) *Bonding.* The electrical bonding arrangements including bonding straps, where fitted, for independent cargo tanks and for the piping systems located within cargo tanks, ballast tanks, pipe tunnels, cofferdams and void spaces bounding cargo tanks are to be examined.
- vi) *Insulation Removals.* Insulation is to be removed in way of any distorted or otherwise suspect insulation or structural part of the cargo tanks or elsewhere to carry out any of the examinations as required by the Surveyor.

See also 7-3-2/5.21.3 and 7-3-2/5.21.7.

3.5 General Dry Cargo Vessels (ESDC) (2004)

3.5.1 Overall Survey Requirements (1 July 2006)

All piping systems within the cargo holds, salt water ballast tanks, including double bottom tanks, pipe tunnels, cofferdams and void spaces bounding cargo holds, decks and outer hull are to be examined and operationally tested to working pressure to the satisfaction of the Surveyor to ensure that tightness and condition remain satisfactory.

3.7 Gas Fueled Vessels other than Liquefied Gas Carriers (1 July 2013)

In addition to the applicable requirement of 7-6-2/1.7, the Special Survey is also to include:

- i) *Fuel Gas Handling and Piping Material.* All piping, machinery and equipment for gas fuel storage, fuel bunkering, fuel gas supply and gas utilization, such as venting, compressing, refrigerating, liquefying, heating storing, burning or otherwise handling the liquefied gas or vapor and liquid nitrogen installations are to be examined including removal of insulation and opening for examination, as deemed necessary. Where deemed suspect, a hydrostatic test to 1.25 times the Maximum Allowable Relief Valve Setting (MARVS) for the pipeline is to be carried out. After reassembly, the complete piping is to be tested for leaks. Where water cannot be tolerated and the piping cannot be dried prior to putting the system into service, the Surveyor may accept alternative testing fluids or alternative means of testing.

- ii) *Fuel Gas Valves.* All emergency shut-down valves, check valves, block and bleed valves, master gas valves, remote operating valves in the gas fuel storage, fuel bunkering, fuel gas supply and gas utilization piping systems are to be inspected and proven operable. The pressure relief valves are to be function-tested. A random selection of valves is to be opened for examination and adjusted as necessary.
- iii) *Pressure Vessels.* Internal examination and thickness measurement of the fitted pressure vessels in the fuel gas storage, fuel gas supply and gas utilization units as deemed necessary by the Surveyor.
- iv) *Electrical Equipment.* Examination and testing of electrical equipment. This examination is to include the physical condition of electrical cables and supports, intrinsically safe, explosion proof, or increased safety features of electrical equipment, functional testing of pressurized equipment and associated alarms, testing systems for de-energizing electrical equipment which is not certified for use in gas-hazardous areas, and insulation resistance readings of circuits. Where a proper record of testing is maintained, consideration may be given to accepting recent readings.

3.9 Vessels with Single or Dual Fuel Engines (1 July 2013)

In addition to the applicable requirements of 7-6-2/1.9, the Special Survey is also to include:

- i) *Gas Turbines.* For dual fuel gas turbine units in continuous service, at least one hot-gas-path examination is to be scheduled each survey cycle and is to include an examination of turbine rotors, fixed blading, combustors, inlet casings (including demisters and filters), exhaust casing (including regenerator), air control valves and protective apparatus.

Other parts of the dual fuel gas turbine and associated equipment, as may be deemed necessary by the attending Surveyor, are to be opened up for examination.

Where units are arranged such that the unit is removed from the vessel in accordance with the approved plans and the maker's recommendations, and dismantled at another facility, the internal examination may be carried out at the facility in the presence of the Surveyor. Upon reassembly/reinstallation, all fuel lines, lube oil piping, the unit itself and exhaust system are to be checked under full speed and its range of operational conditions for leakage.

PART

7

CHAPTER 6 Machinery Surveys

SECTION 3 Vessels in Great Lakes Service

1 Special Periodical/Continuous Surveys – Machinery – Year of Grace (1998)

In addition to the survey requirements of Section 7-6-2, when the Owner applies for a Year of Grace Survey, this will also apply to the Special Periodical Survey – Machinery or Continuous Survey – Machinery items that are not normally examined with the vessel afloat, such as the controllable pitch propeller system, main drive shaft couplings, thrust bearings, sea valves and chests, etc. Upon external examinations and review of records to the satisfaction of the attending Surveyor, such items may also be granted the Year of Grace Survey.

PART
7

CHAPTER 7 Boiler Surveys

CONTENTS

SECTION 1	Survey Requirements.....	173
1	Internal and External Examinations	173
3	Boiler Mountings and Safety Valves	173
5	Waste Heat Boilers	173
7	Record Review.....	173
9	Hydrostatic Testing	173
9.1	Post Repairs and/or Modifications	173
9.3	Auxiliary Boilers	173
11	Survey Extensions	174
13	Annual Examination	174

PART

7

CHAPTER 7 Boiler Surveys

SECTION 1 Survey Requirements

1 Internal and External Examinations

At each survey, the boilers, superheaters, and economizers are to be examined internally (water-steam side) and externally (fire side).

3 Boiler Mountings and Safety Valves *(1 July 2002)*

Boiler mountings and safety valves are to be examined at each survey and opened, as considered necessary by the Surveyor.

(2007) The safety valves are to be tested and the proper operation of the safety valves is to be confirmed at each survey.

Boiler safety valve relieving gear (easing gear) is to be examined and tested to verify satisfactory operation. This test is to be carried out prior to any safety valve operation or setting test under steam.

(2007) For waste heat boilers, if steam cannot be raised at port, the safety valves may be tested and set by the Chief Engineer at sea, and the results recorded in the log book for review by the Surveyor.

5 Waste Heat Boilers *(2007)*

In addition to the other requirements of Section 7-7-1, for waste heat boilers of the shell type, all accessible welded joints are to be subjected to an examination for fractures at each survey. Nondestructive testing may be required for this purpose.

7 Record Review *(2007)*

Review of the following records since the last Boiler Survey is to be carried out at each survey.

- Operation
- Maintenance
- Repair history
- Feedwater chemistry

9 Hydrostatic Testing *(2017)*

9.1 Post Repairs and/or Modifications

After repairs and/or modification to pressurized parts or when considered necessary by the Surveyor, the boilers and superheaters are to be subjected to hydrostatic pressure test.

9.3 Auxiliary Boilers

Auxiliary boilers that cannot be examined internally are to be hydrostatically tested at their rated working pressure.

11 Survey Extensions (2005)

An extension may be granted by the Surveyor after the following is satisfactorily carried out:

- i) External examination of the boiler
- ii) Boiler safety valve relieving gear (easing gear) is to be examined and operationally tested
- iii) (2007) Boiler protective devices (alarms and shutdowns) operationally tested
- iv) Review of the following records since the last Boiler Survey:
 - Operation
 - Maintenance
 - Repair history
 - Feedwater chemistry

13 Annual Examination (2007)

External examination of boilers including test of safety and protective devices, and test of safety valve using its relieving gear, is to be carried out annually, within the window of the Annual Survey of the vessel.

(2009) For waste heat boilers, the safety valves are to be tested under steam by the Chief Engineer at sea using its relieving gear within the annual survey window. This test is to be recorded in the log book for review by the attending Surveyor prior to crediting the Annual Survey of Machinery.

PART
7

CHAPTER 8 Shipboard Automatic and Remote-control
Systems

CONTENTS

SECTION 1	Annual Surveys	176
1	General	176
3	Fire Safety Systems.....	176
5	Machinery Records.....	176
SECTION 2	Special Periodical Surveys.....	177
1	Control Actuators	177
3	Electrical.....	177
	3.1 Insulation Resistance Readings	177
	3.3 Automatic Controls	177
5	Dock Trials	177

PART

7

CHAPTER 8 Shipboard Automatic and Remote-control Systems

SECTION 1 Annual Surveys

In order to retain the **ACC**, **ACCU** or **ABCU** symbol, at each Annual Survey, the automatic and remote-control systems are to be generally examined so far as can be seen and placed in satisfactory condition. The survey is also to include:

1 General (2004)

The examination is to be made with a ship's service generator in operation and the control system energized to permit random checking of the following function indicators, alarms, shutdowns and such control actuators as may be operational to the satisfaction of the attending Surveyor:

- Lamp test of alarm indicators
- Power supply arrangements and automatic controls
- Automatic controls for the propulsion system
- Automatic controls for the main/auxiliary boiler system
- Automatic controls for thermal fluid heaters
- Automatic changeover of selected pumps
- Automatic starting of and controls for the emergency generator
- Bridge and engineer's accommodation function and alarm indicators
- Fuel oil system arrangements and alarms
- Machinery space bilge level alarms

3 Fire Safety Systems (2004)

Fire safety systems, including operational tests of the fire detecting system. Fire Fighting Station controls and equipment, if fitted.

The arrangements made to ensure immediate availability of a supply of water from the fire main at the required pressure either by permanent pressurization or by remote starting arrangements for the fire pumps are to be verified.

5 Machinery Records (2001)

The Surveyor is to examine the machinery records to check the performance of the control system throughout the period since the last survey and to establish if there has been any abnormal functioning or failures and what corrective measures had been taken to preclude their recurrence.

PART

7

CHAPTER 8 Shipboard Automatic and Remote-control Systems

SECTION 2 Special Periodical Surveys

In order to retain the **ACCU**, **ACC** or **ABCU** symbol, at each Special Periodical Survey, the following items are to be examined and placed in satisfactory condition:

1 Control Actuators

All mechanical, hydraulic and pneumatic control actuators and their power systems are to be examined and tested, as considered necessary.

3 Electrical

3.1 Insulation Resistance Readings

The insulation resistance of the windings of electrical control motors or actuators is to be measured, with all circuits of different voltages above ground being tested separately, and is to be on the order of one-half to one megohm.

3.3 Automatic Controls (2001)

Automatic controls for the electrical power generating system, including auto start, parallel operation and load shedding function.

5 Dock Trials (2001)

In addition to the Annual Survey requirements, control systems are to be subjected to dock trials at reduced power on the propulsion engine to check the proper performance of the following automatic functions, alarms and safety systems:

- Function test of alarm system.
- Function test of safety system, including override of system functions.
- Manual control of machinery.
- Loss and restoration of power.
- Propulsion remote control, including propulsion control transfer, propulsion starting, verification of propulsion control power failure, automatic propulsion shutdown, automatic propulsion slow-down, actuation of propulsion emergency stop devices and for turbine-driven vessel, actuation of the shaft turning device.

PART
7

CHAPTER 9 Survey Requirements for Additional Systems and Services

CONTENTS

SECTION 1	Cargo Refrigeration System	183
1	RCC, RCCC, RMC, REBLT, RFC or RC(HOLD) Notation	183
1.1	Annual Surveys	183
1.3	Special Periodical Surveys	184
1.5	Loading Surveys	185
3	APLUS, ASLS or SASLS Notation.....	186
3.1	Annual Surveys	186
3.3	Re-Testing Survey	186
5	CA or CA(INST) Notation.....	186
5.1	Annual Surveys	186
5.3	Special Periodical Surveys	188
SECTION 2	Hull Condition Monitoring System.....	189
1	HM1, HM2, HM3 Notation.....	189
1.1	Annual Surveys	189
1.3	Special Periodical Surveys	189
SECTION 3	One Man Bridge Operated System.....	190
1	OMBO Notation.....	190
1.1	Annual Surveys	190
SECTION 4	Propulsion Redundancy System.....	191
1	R1, R2, R1-S or R2-S Notation.....	191
1.1	Annual Surveys	191
SECTION 5	Quick Release System	192
1	QR Notation	192
1.1	Special Periodical Surveys	192
SECTION 6	Thrusters and Dynamic Positioning System	193
1	PAS and APS Notations	193
1.1	Annual Surveys	193
1.3	Special Periodical Surveys	193
3	DPS-0, DPS-1, DPS-2, DPS-3 Notations	194
3.1	Annual Surveys	194
3.3	First Drydocking Survey After Delivery	198
3.5	Special Surveys	198

SECTION 7	Vapor Emission Control System.....	199
1	VEC Notation	199
1.1	Annual Surveys	199
1.3	Special Periodical Surveys.....	200
3	VEC-L Notation	200
3.1	Annual Surveys	200
3.3	Special Periodical Surveys.....	201
SECTION 8	Fire Fighting Service.....	202
1	FFV Class 1, FFV Class 2 and FFV Class 3 Notation.....	202
1.1	Annual Surveys for Fire Fighting Vessels.....	202
3	FFV Class 1 Notation.....	202
3.1	Annual Surveys for Fire Fighting Vessels.....	202
5	FFV Class 2 Notation.....	203
5.1	Annual Surveys for Fire Fighting Vessels.....	203
7	FFV Class 3 Notation.....	203
7.1	Annual Surveys for Fire Fighting Vessels.....	203
SECTION 9	Safety Standby Service.....	204
1	Safety Standby Service Notation	204
1.1	Annual Surveys and Surveys after Each Rescue Operation or Evacuation.....	204
SECTION 10	Offshore Installations Support Service	206
1	Offshore Support Vessel Notation	206
1.1	Annual Surveys for Offshore Support Vessels	206
1.3	Annual Surveys for Anchor Handling/Offshore Support Vessels.....	206
1.5	Annual Surveys for Well Stimulation/Offshore Support Vessels.....	206
3	Vessels with SPS Notation	206
3.1	Annual Surveys	206
5	Offshore Supply Notation.....	207
5.1	Annual Surveys	207
5.3	Special Surveys.....	207
7	Vessels with the Supply HNLS Notation.....	207
7.1	Annual Surveys	207
7.3	Special Surveys.....	208
9	Vessels with the AH, TOW, and AH, TOW Notations.....	208
9.1	Annual Surveys	208
9.3	Special Surveys.....	208
11	Vessels with the ROV Notation.....	209
11.1	Annual Surveys	209
13	Vessels with the ROV Capable and DSV Capable Notations	209
13.1	Annual Surveys	209
15	Vessels with the DSV Notation	209
15.1	Annual Surveys	209

17	Vessels with the Pipe Lay Notation	210
17.1	Annual Surveys	210
17.3	Special Surveys	211
19	Vessel with the Heavy Lift Notation	211
19.1	Annual Surveys	211
21	Vessels with the Escort or QR Notation.....	211
21.1	Annual Surveys	211
21.3	Special Surveys	211
23	Vessels with the WIND-IMR Notation	212
23.1	Annual Surveys	212
25	Vessels with the Cable Lay Notation	212
25.1	Annual Surveys	212
27	Vessels with the WI Notation	212
27.1	Annual Surveys	212
27.3	Special Surveys	213
29	Vessels with in the WI-Ready Notation.....	213
29.1	Annual Surveys	213
31	Vessels with the WI-Temp Notation.....	213
31.1	Annual Surveys	213
33	Well Intervention Vessels with no Specific Notation.....	213
33.1	Annual Surveys	213
35	OSV Well Stimulation Vessels with no Class Notation.....	214
35.1	Annual Surveys	214
37	Vessels with the WS-Ready Notation	214
37.1	Annual Surveys	214
39	Vessels with the WS-Temp Notation	214
39.1	Annual Surveys	214
41	Vessels with the WS Notation.....	214
41.1	Annual Surveys	214
43	Vessels with Well Test Systems with no Notation	215
43.1	Annual Surveys	215
45	Vessels with the WT-Ready and WT-Temp Notations	215
45.1	Annual Surveys	215
47	Vessels with the Well Test Service Notation	216
47.1	Annual Surveys	216

SECTION 11 Oil Recovery Service..... 217

1	Oil Spill Recovery – Standby Class 1 and 2 Notation.....	217
1.1	Annual Surveys	217
1.3	Special Periodical Surveys	217
1.5	Survey After Each Oil Recovery Operation.....	217
3	Oil Spill Recovery – Capability Class 1 and 2 Notation	217
3.1	Annual Surveys	217
3.3	Special Periodical Surveys	218
3.5	Survey Before Oil Recovery Operation.....	218
3.7	Survey After Each Oil Recovery Operation.....	218

SECTION 12	Automatic or Remote Control and Monitoring Systems for Vessels in Port	219
1	PORT Notation.....	219
1.1	Annual Surveys	219
SECTION 13	Bridge Design and Navigational Equipment/ Systems	220
1	NBLES Notation.....	220
1.1	Annual Surveys	220
3	NIBS Notation	220
3.1	Annual Surveys	220
SECTION 14	Integrated Tug-Barge (ITB) Combinations Intended to Operate on the Great Lakes	221
1	DM and PM Notation.....	221
1.1	Annual Surveys	221
SECTION 15	Environmental Safety.....	222
1	Environmental Safety (ES) Notation	222
1.1	Annual Survey	222
3	Environmental Protection (ENVIRO and ENVIRO+) Notations for Vessels.....	222
3.1	ENVIRO Notation	222
3.3	ENVIRO+ Notation	223
SECTION 16	Crew Habitability on Ships and Workboats	225
1	Annual Surveys.....	225
3	Special Periodical Surveys	225
3.1	Survey Requirements.....	225
5	Requirements for Vessel Alterations	226
SECTION 17	Comfort on Ships and Yachts	227
1	Annual Surveys.....	227
3	Special Periodical Surveys	227
3.1	Survey Requirements.....	227
3.3	Passenger Comfort on Ships.....	228
3.5	Comfort on Yachts.....	228
5	Requirements for Vessel Alterations	229
SECTION 18	Compliance with the ILO Maritime Labour Convention, 2006 Title 3 Requirements	230
1	Annual Surveys.....	230
3	Special Periodical Surveys	230
3.1	Survey Requirements.....	230
5	Requirements for Vessel Alterations	231

SECTION 19	Yachts	232
1	All Yachts	232
1.1	Annual Survey	232
3	Commercial Yachting Service Notation	232
3.1	Annual Survey	232
5	Passenger Yachting Service Notation	232
5.1	Annual Survey	232
SECTION 20	Tailshaft Condition Monitoring	233
1	TCM Notation	233
1.1	Annual Survey	233
1.3	Initial Survey for Existing Vessels obtaining TCM Notation	233
SECTION 21	Oil Carriers Equipped for Mooring at Single Point Moorings	234
1	SPMA Notation	234
1.1	Annual Surveys	234
1.3	Special Periodical Surveys	234
SECTION 22	Inert Gas Systems for Ballast Tanks	235
1	IGS – Ballast Notation	235
1.1	Annual Surveys	235
1.3	Special Periodical Surveys	235
SECTION 23	Inventory of Hazardous Materials	236
1	Introduction	236
3	Annual Survey	236
5	Additional Survey	236

PART
7

CHAPTER 9 Survey Requirements for Additional Systems and Services

SECTION 1 Cargo Refrigeration System

1 RCC, RCCC, RMC, REBLT, RFC or RC(HOLD) Notation

1.1 Annual Surveys

1.1.1 Refrigeration Installation

The cargo refrigeration installation is to be generally examined so far as can be seen and placed in satisfactory condition. This is to include an examination and test of the machinery under working conditions and should include the following:

1.1.1(a) Liquid and Gas Piping. Liquid and gas piping, together with their respective valves, receivers separators, condensers and evaporator coil terminals are to be examined externally, as far as practicable.

1.1.1(b) Direct-Expansion System. Where a direct-expansion system is employed, the cooling coils are to be examined under working conditions.

1.1.1(c) Brine System. The brine return tanks, brine pumps piping and valves are to be examined, as far as practicable. Where brine may escape to bilges, the cement, where fitted, is to be examined.

1.1.1(d) Insulation. The insulation is to be carefully examined and bored, where considered necessary, particularly under line of decks and side stringers in order to determine fullness and dryness. The test holes are to be subsequently closed. The cargo battens, gratings, where fitted, are to be examined.

1.1.1(e) Cargo Gratings. The cargo gratings are to be examined. All limbers are to be removed, the bilge or bilge wells cleaned, and the suction and sounding pipes examined. All hatches and access doors, air trunks, thermometer tubes, ventilator coamings and deck connections are to be examined and where air trunks pass through watertight bulkheads, the watertight doors are to be worked.

1.1.1(f) Ventilators. Ventilators to refrigerated spaces, including their closing appliances, are to be examined for satisfactory condition and operation.

1.1.1(g) Bulkhead and Deck Penetrations. Bulkhead and deck penetration seals of refrigerant pipes are to be examined.

1.1.1(h) Alarm and Monitoring Systems. The alarm and monitoring systems, including cargo hold temperature measurement equipment and CO₂ content meters, are to be generally examined and to be proven in satisfactory condition. Evidence of periodic instrument calibration is to be verified.

1.1.1(i) Air Coolers and Cooling Grids. The drainage arrangements, including liquid seal traps, drip trays under air coolers or cooling grids, are to be examined for satisfactory condition.

1.1.1(j) Hatch Covers. Drainage and sealing arrangements between the double seals of exposed hatch covers.

1.1.2 Ammonia Refrigerating Plant

The following features of the Ammonia refrigerating machinery space are to be surveyed and placed in satisfactory condition:

1.1.2(a) Ammonia Refrigeration Machinery Spaces. Confirmation of gas tightness of Ammonia refrigeration machinery space, including access doors and all bulkhead and deck penetrations.

1.1.2(b) Exhaust Ventilation System. Examination and testing of independent exhaust ventilation system, including the confirmation that a catastrophic leak of Ammonia is easily and rapidly dissipated by means of an automatic starting arrangement of the exhaust ventilation system.

1.1.2(c) Water Dump Tank. Examination of water dump tank, including venting arrangements, level alarms and water supply control.

1.1.2(d) Water Drainage Arrangements. Examination and operational test of independent water drainage arrangements.

1.1.2(e) Spare. General examination of the spare Ammonia storage space, including ventilation, handling and storage/securing arrangements.

1.1.2(f) Vapor Detection and Alarm Systems. Examination and testing of the two (2) required Ammonia vapor detection and alarm systems including the automatic shut-down of the refrigerating plant and activation of exhaust ventilation system.

1.1.2(g) Electrical Equipment. Confirmation that electrical equipment within the Ammonia refrigerating machinery space complies with the requirements for hazardous areas.

1.1.2(h) Personal Safety Equipment. Confirmation that the following personal safety equipment is stored outside of the Ammonia refrigerating machinery space.

- Eye wash and shower unit (at entrance).
- One (1) set of fireman's outfit (in addition to SOLAS requirements).
- One (1) heavy-duty adjustable wrench.
- Boric acid, vinegar and eye cups.

1.1.3 RCCC Notation (only)

In addition to the applicable requirements of 7-9-1/1.1.1 and 7-9-1/1.1.2, the following special features of container ships which are fitted with a refrigerating plant for supplying cooled air to insulated containers are to be examined and placed in satisfactory condition:

1.1.3(a) Air Duct System. An operational test is to be carried out of the air duct system supplying cooled air to the containers, together with air coolers and circulating fans, and the flexible connections to the containers.

1.1.3(b) Air Duct Sensors. Examination of air duct thermometers and or remote temperature sensing apparatus for satisfactory condition and accuracy.

1.3 Special Periodical Surveys

1.3.1 Cargo Refrigerating Plant

1.3.1(a) Machinery Operation. The machinery is to be examined under working conditions and the vessel's logs examined to ascertain satisfactory operation.

1.3.1(b) Compressors and their Motors. Centrifugal or reciprocating compressors are to be opened up and examined. Motors driving the compressors, together with gears and air circulating fans, if fitted, are to be opened up and examined as considered necessary by the Surveyor, unless they are maintained under an approved planned maintenance program. For electric motors, the insulation resistance is to be measured unless satisfactory records are made available.

1.3.1(c) Insulation and Coating. The fullness and dryness of the insulation is to be confirmed in accordance with requirements of 7-9-1/1.1.1(d).

The condition of the coating behind the insulation in cargo spaces is to be examined at random. The examination may be limited to verification that the protective coating remains effective and that there are no visible structural defects. Where POOR coating condition is found, the examination is to be extended at the discretion of the Surveyor. The coating is to be reported on.

1.3.1(d) Primary Refrigerating System. The entire primary refrigerating system, including condensers, economizers, evaporators, brine coolers, receivers, oil receivers, refrigerant storage tanks, oil coolers, dryers, direct expansion cooling coils and such other similar equipment, are to be examined and leak-tested at their working pressure.

1.3.1(e) Piping. Refrigerant piping, including brine piping, is to be examined and insulation is to be removed as deemed necessary by the Surveyor. The entire brine system, including air coolers, is to be hydrostatically tested to maximum working pressure. Coating condition of piping or other corrosion protection is to be examined.

1.3.1(f) Relief Valves. All relief valves and/or other pressure relieving devices of the refrigerating system are to be tested and verified for correct setting.

1.3.1(g) Brine System. Brine heaters, brine expansion tanks, brine mixing tank and brine air coolers are to be opened, examined.

1.3.1(h) Pumps. Condenser sea water cooling pumps, brine pumps and refrigerant pumps where installed, are to be opened and examined.

1.3.1(i) Bulkhead and Deck Penetration Seals. Bulkhead and deck penetration seals of refrigerant pipes are to be examined.

1.3.1(j) Defrosting. Arrangement for defrosting, where fitted, are to be confirmed in satisfactory condition.

1.5 Loading Surveys

When requested by the Owner, a survey will be carried out and a Loading Certificate issued, provided the cargo refrigerating installation has been maintained in class. Loading Certificates for the individual thermal containers are to be issued in accordance with the *Rules for Certification of Cargo Containers*.

1.5.1 Surveys for Vessels Carrying Cargo in Refrigerated Holds

The survey is to consist of an inspection to ascertain that the chambers and drain pipes are clean, that the cargo battens (when fitted) are in good order and that the insulation and refrigerating pipes have not sustained damage. A test of the refrigerating machinery and air circulating system under working conditions is to be witnessed and the temperatures in the various chambers noted, as well as ambient temperature.

1.5.2 Surveys for Vessels Carrying Cargo in Portable Insulated Containers Refrigerated by Shipboard Equipment

The Survey is to consist of an inspection to ascertain that the container stowage areas are dry and the stowage fittings are in order, that the drains in the stowage areas are clean and that the refrigeration system connections to the individual containers are in good order and free from damage. An operational test of the refrigerating machinery and air circulating system under the prevailing conditions is to be witnessed, and proper operation of the system verified.

When requested by the Owner, an additional survey may be made after loading to verify that the refrigeration system connections to the individual containers have been properly made, with unused connections properly sealed off. At this survey, proper operation of the refrigerating machinery under working conditions is to be verified, and the temperatures of the individual containers noted, where practicable, as well as the ambient temperature.

3 APLUS, ASLS or SASLS Notation

3.1 Annual Surveys

3.1.1 Automatic Pallet Loading and Unloading System

The system is to be generally examined, as practicable, and placed in satisfactory condition, as follows:

3.1.1(a) Load Bearing Structure. Examination of the load bearing structure for deformations, excessive wear, corrosion, damage or fractures.

3.1.1(b) Pallet Handling Machinery. External and internal examination of the pallet handling machinery, including prime movers, gears, clutches, hoisting and slewing equipment, brakes, hoisting cables, guide rails and guide shoes or rollers, travel wheels.

3.1.1(c) Wire Ropes and Chains. Examination of the wire ropes and/or chains.

3.1.1(d) Safety Devices. Functional testing of the safety devices including, interlocks and limiting devices, is to be carried out.

3.3 Re-Testing Survey

At intervals not exceeding five years, in addition to the requirements of Annual Surveys, the pallet handling system is to undergo testing and examination.

3.3.1 Proof Load Testing

Proof load testing of 125% SWL is to include hoisting and lowering of the equipment and testing of fail safe and limiting device. After being tested, the equipment is to be examined to ensure that no part has been damaged or permanently deformed by the test.

3.3.2 Brakes and Fail Safe Devices

The operation of all brakes and fail-safe devices are to be demonstrated under simulated loss of power conditions to the satisfaction of the Surveyor.

3.3.3 Administration Requirements

Where administrations require re-testing of the pallet handling system at intervals other than those mentioned above, ABS is prepared to carry out such re-testing and note same in the class certificate.

5 CA or CA(INST) Notation

5.1 Annual Surveys

5.1.1 Controlled Atmosphere System

The system is to be generally examined, as practicable, and placed in satisfactory condition, as follows:

5.1.1(a) General

i) Monitoring and Control Systems. The monitoring and control systems are to be generally examined under working condition, as far as practical.

ii) Machinery Records. Machinery records are to be checked for the performance of the system, including the monitoring and control systems throughout the period since the last survey.

iii) Compressors and Piping. External examination of all compressors and piping, including where provided carbon dioxide scrubbers, ethylene scrubbers, carbon dioxide supply equipment and humidifiers.

iv) Monitoring System. Confirmation that the plant is set to automatically achieve and maintain design O₂ and CO₂ levels in all controlled atmosphere cargo spaces and that permanent monitoring system is in satisfactory operating condition.

- v) *Alarms and Safety Devices.* Confirmation of the satisfactory operation of the following alarms and safety devices, including verification of posted warning notices.
- Safety devices of each compressor and all pressure vessels.
 - Stopping devices of gas generators and ventilators outside of space.
 - Automatic alarm at each space prior to discharge of medium.
 - Pressure and vacuum valves at each space.
 - Portable equipment for measuring O₂ and CO₂ levels.
 - Permanently installed O₂ level alarms in gas separator equipment spaces, monitor O₂ level at the desired values and alarming low level O₂.
 - Centralized monitoring control system, where fitted.
- vi) *Warning Notices.* Confirmation that warning notices are posted, that gas generating compartment or container complies with the requirements for hazardous area with regard to suitability of electrical equipment, ventilation, access, etc. Also, that there are warning notices posted on all hatch covers and doors leading to spaces under controlled atmosphere.
- vii) *Liquid Seal Traps.* Confirmation that all liquid seal traps on drains from cargo spaces such as the air cooler trays are in satisfactory condition.
- viii) *Ventilation System.* Confirmation of satisfactory operation of positive pressure ventilation systems of all accessible spaces adjacent to spaces under controlled atmosphere, including controls for ventilation system from outside the space(s).
- ix) *O₂ Level Monitoring Equipment.* Confirmation of satisfactory operation of permanently installed O₂ level monitoring equipment, including testing of alarms for low O₂ levels in all normally accessible spaces adjacent to spaces under controlled atmosphere.
- 5.1.1(b) *Humidifying System (where fitted)*
- i) *Humidifying System.* Confirmation of satisfactory operation of humidifying systems in all refrigerated cargo spaces, including drainage and heating arrangements.
- ii) *Humidifying Monitoring Equipment.* Confirmation of satisfactory operation of permanently installed humidity monitoring equipment in all cargo holds, including individual alarms for deviations of relative humidity.
- 5.1.1(c) *Personal Safety Equipment.* Confirmation of availability of following Personal Safety Equipment:
- At least ten (10) portable oxygen content meters with alarms.
 - One (1) portable gas analyzer capable of measuring O₂ levels in the spaces under controlled atmosphere in addition to the portable equipment required by 7-9-1/5.1.1(a)v).
 - Three (3) sets of portable radio telephone apparatus - two way communication between cargo space under controlled atmosphere and the Nitrogen generating space, in addition to those required by SOLAS Chapter III, Reg. (6).
 - One (1) set of resuscitation equipment.
 - Two (2) sets of self-contained breathing apparatus equipped with built in radio communication lifeline with belt and one each fully charged spare air container with a capacity of 3000 liter, in addition to those required by SOLAS Chapter II (2), Reg. (17).

5.1.2 Control and Monitoring Systems

At each Annual Survey, the control and monitoring systems are to be generally examined so far as can be seen and placed in satisfactory condition. The examination is to be made with one or more ship's service generator(s) in operation and the control system energized to permit random checking of function indicators, alarms and such control actuators as may be operational. The Surveyor is to examine the refrigerating machinery records to check the performance of the control system throughout the period since the last survey and to establish if there have been any abnormal functioning or failures and the corrective measures taken to preclude their recurrence.

5.3 Special Periodical Surveys

The following items are to be examined at each Special Periodical Survey:

5.3.1 Controlled Atmosphere Spaces

All gastight spaces are to be tested for tightness.

5.3.2 Controlled Atmosphere Equipment

All equipment is to be examined and opened up, as considered necessary by the Surveyor.

5.3.3 Controlled Atmosphere Alarms and Controls

All equipment, including alarms, controls, sampling systems and instrumentation, is to be operated to the satisfaction of the Surveyor.

PART

7

CHAPTER 9 Survey Requirements for Additional Systems and Services

SECTION 2 Hull Condition Monitoring System

1 HM1, HM2, HM3 Notation

The equipment and arrangements required for the optional class notation **HM1**, **HM2** or **HM3** (plus **R+** if applicable) are to be examined, as follows:

1.1 Annual Surveys

The following items are to be examined, placed in satisfactory condition and reported on:

- The operation of the system is to be verified in accordance with the approved verification procedure.
- The existence of current calibration certificates for the sensors and the Operating Manual are to be established.
- The protection of sensors is to be examined.

1.3 Special Periodical Surveys

The following items are to be examined, placed in satisfactory condition and reported on:

- The operation of the system is to be verified in accordance with the approved verification procedure.
- Sensors fitted in exposed locations are to be hose-tested to confirm weathertightness.

PART

7

CHAPTER 9 Survey Requirements for Additional Systems and Services

SECTION 3 One Man Bridge Operated System

1 OMBO Notation

1.1 Annual Surveys

At each Annual Survey, the equipment and arrangements for One Man Bridge Operation are to be generally examined so far as can be seen and placed in satisfactory condition. The survey is also to include:

1.1.1 Operations Manual

Confirmation of an Operations Manual specifying the conditions under which a one man watch is permitted and emergency plans are onboard.

1.1.2 Transmitting Device

Operation of the transmitting device reproducing external sound signals inside the wheelhouse.

1.1.3 Instrumentation and Controls

Confirmation, as far as practicable, of satisfactory performance of the required instrumentation and controls pertaining to safety of navigation including ARPA, automatic pilot, position fixing systems, radars, gyro compass, speed log, echo sounding systems and any associated alarms. This is to include examination of equipment records for abnormal functioning or failures and what corrective measures were taken to preclude their recurrence.

1.1.4 Operational Testing

Operation of controls, including propulsion plant remote control system, whistle control device, window wipe and wash control device, workstation console lighting control, steering pump selector/control, internal communication, VHF radiotelephone, wheelhouse heating/cooling controls and NAVTEX automatic receiver and recorder.

1.1.5 Automatic Transfer and Changeover

Watch officer alertness system, including automatic transfer to the master and automatic changeover to standby power in the event of loss of normal power.

PART
7

CHAPTER 9 Survey Requirements for Additional Systems and Services

SECTION 4 Propulsion Redundancy System

1 R1, R2, R1-S or R2-S Notation

The equipment and arrangements required for the optional class notation **R1**, **R2**, **R1-S**, or **R2-S** (plus + if applicable) are to be examined, as follows:

1.1 Annual Surveys

The following items are to be examined, placed in satisfactory condition and reported on:

- Ready availability and validity of the approved operating manual.
- Sampling of fault simulation tests for the redundancy arrangements to verify that upon any single failure, the propulsion and steering systems remain operational, or the back-up propulsion and steering systems may be speedily brought into service.
- The effectiveness of the communication system required by SVR 4-8-2/11.5 is to be tested to confirm that local control of propulsion systems may be carried out satisfactorily.

PART

7

CHAPTER 9 Survey Requirements for Additional Systems and Services

SECTION 5 Quick Release System

1 QR Notation

1.1 **Special Periodical Surveys**

At each Special Periodical Survey, the quick release system is to be generally examined as far as can be seen and placed in satisfactory condition. The effectiveness of the quick release device is to be demonstrated. The test is to be conducted to the manufacturer's recommendations in the presence of the attending Surveyor.

PART
7

CHAPTER 9 Survey Requirements for Additional Systems and Services

SECTION 6 Thrusters and Dynamic Positioning System

1 PAS and APS Notations

1.1 Annual Surveys (1 July 2008)

At each Annual Survey, the thruster installation is to be generally examined so far as can be seen and placed in satisfactory condition. The survey is also to include:

1.1.1 Controls and Alarms

Verification of effective means of control from both the Navigation Bridge and local control stations, including alarms and indicators. The following audible and visual alarms at each control station are to be visually examined, verified operational and considered satisfactory, as applicable:

- i)* Engine low lubricating oil pressure
- ii)* Engine coolant high temperature
- iii)* Motor overload
- iv)* Thruster RPM
- v)* Thrust direction (azimuthing type)
- vi)* Thruster power supply failure
- vii)* Controllable pitch propellers hydraulic low oil pressure
- viii)* Controllable pitch propellers hydraulic high oil pressure
- xi)* Controllable pitch propellers hydraulic oil high temperature
- x)* Fire extinguishing systems

1.1.2 Communication

Means of voice communication between the bridge control station, main propulsion control station and the thruster room are to be tested and found satisfactory.

1.1.3 Thruster Room

Thruster room arrangements, including adequate ventilation, bilge system and alarms for enclosed modules and firefighting systems are to be examined, tested and considered satisfactory.

1.3 Special Periodical Surveys (1 July 2004)

1.3.1 All Thrusters (2007)

In addition to the requirements of the Annual Survey, thrusters are to be surveyed as part of the Special Periodical Survey including the following:

- i)* External examination including propeller, gear housing, bolting and their securing arrangements and for seal leakage.
- ii)* Examination of propeller shaft.

- iii) Internal examination including gear train assembly, bearing and seal assemblies.
- iv) Lubrication oil sample analysis.
- v) In addition, for controllable pitch propellers, blade seal leak check and functional test.

Where deemed necessary by the Surveyor, nondestructive testing may be required.

At the first Special Periodical Survey after delivery, on the basis of a satisfactory service record, lubrication oil sample analysis and external examination, the propeller shaft and internal examinations may be specially considered by the Surveyor.

Prime movers are to be examined and tested, as per applicable requirements of 7-6-2/3.

1.3.2 Water-Jet Type Thrusters (2007)

In addition to the applicable requirements of 7-9-6/1.3.1, the survey is also to include the following.

- i) External examination including steering nozzle and astern deflector
- ii) Internal examination including impeller, stator, impeller shaft, water duct, journal and thrust bearings and shaft seals.

1.3.3 Cycloidal Propellers (2007)

In addition to the applicable requirements of 7-9-6/1.3.1, the survey is also to include the following.

- i) External examination including blades, blade seal leak check and functional test.

3 DPS-0, DPS-1, DPS-2, DPS-3 Notations

3.1 Annual Surveys (2017)

(1 July 2013) In addition to the requirements for **PAS** and **APS** at each Annual Survey, the vessel is to be operated for a duration of at least two hours to demonstrate that the dynamic positioning system has been maintained properly and is in good working order. The operational testing is to be carried out to the Surveyor's satisfaction the tests are to demonstrate the level of redundancy established by the FMEA (Failure Modes and Effects Analysis, see Subsection 2/11 of the *ABS Guide for Dynamic Positioning Systems*).

In addition, the following items are to be generally examined **and tested** so far as can be seen and placed in satisfactory condition:

3.1.1 Documentation

The following accepted documents are to be confirmed onboard the vessel as applicable:

- i) DP FMEA
- ii) DP Trial Test Procedures/Results of Trials
- iii) DP Operations Manual
- iv) ESD Operations Manual

3.1.2 Controls and Alarms

Control system, including independent emergency shut-down facility for each thruster at the main dynamic positioning control station, position keeping redundancy, and alarms and instrumentation are to be generally examined and confirmed to be functioning satisfactorily.

3.1.3 Position and Environment Sensors

All available position sensors, wind sensors(s) and gyro-compass(s) are to be generally examined and confirmed to be functioning satisfactorily.

3.1.4 For DPS-1 Notation

The operation of the automatic control system and a manual position control system including manual transfer of control between the two systems is to be confirmed to be functioning satisfactorily.

- i) Verification that any DP system hardware changes that may affect the DP Class Notation for the unit have been submitted, approved, and tested as required.
- ii) Confirmation that any software revisions since the time of last Survey have been tracked and tested as appropriate by Owner and suitably documented for record.
- iii) Any hardware or software changes that have not been tested since the last performance test shall have functionality proven and recorded by a supplementary trials program to verify the effect of the modifications with regard to the approved redundancy arrangements for the unit.

3.1.5 For DPS-2 Notation

The operation of two automatic control systems and a manual position control system including automatic transfer of one automatic control system to another upon failure is to be confirmed to be functioning satisfactorily. Upon failure of the two automatic control systems, it is to be verified that the manual position control is possible. See 7-9-6/3.1.6.

Additionally the following to be confirmed/tested:

i) *General System*

- Black out recovery test shall be conducted.
- The following redundant equipment shall be disabled or disconnected in order to demonstrate operational capability after such simulated failure / condition:
 - Position reference systems
 - Worse case failure (e.g. switchboard, transformer, engine, or thruster as applicable)
 - Network arrangements
- Demonstration of open bus power management systems.
- Demonstration of closed bus power management systems where such closed bus arrangements have been reviewed and accepted / approved by the Bureau.

ii) *Standby and Power Redundancy*

- Test thruster supply and generator feeder automatic transfer switches
- The tests will exercise the changeover functions as well as the redundant supplies.
- The standby and power redundancy tests may be combined with the tests of the Worst Case Failure Design Intent identified in the DP FMEA. Changeover to the standby DP Control Station is to be tested.
- Changeover to standby auxiliary services, such as seawater or freshwater cooling pumps and hydraulic pumps, shall be tested where these auxiliaries provide essential redundancy as identified in the DP FMEA.
- Test the switchover and isolation of redundant DC power supplies, such as in control power circuits. Where one DC power supply is failed or removed, voltage or current from the redundant DC power supply or any other source should not be present at the failed power supply.

3.1.6 For DPS-3 Notation

Completion of all items for DPS-2 Notation

The operation of three automatic control systems and a manual position control system including automatic transfer of one automatic control system to another upon failure is to be confirmed to be functioning satisfactorily. Manual transfer of control is to be verified possible at the third automatic control system located in the emergency back-up control station. Upon failure of the automatic control systems, it is to be verified that the manual position control is possible. See 7-9-6/3.1.6.

Additionally, the following are to be confirmed/tested:

- i) The following redundant compartments shall be disabled or disconnected in order to prove operational capability after failure
- ii) Main Control station
- iii) Worst case failure compartment (e.g. engine room, switchgear room, thruster room, or other space)
- iv) Verification that no changes have been made to the watertight integrity and fire subdivisions of compartments containing elements of the DP and associated systems.

3.1.7 Manual Position Control System for DPS-1, DPS-2, and DPS-3 Notations

The operation of the manual position control system using one joystick on the Navigation Bridge or DP control station in accordance with Subsection 5/7 of the *ABS Guide for Dynamic Positioning Systems* 4-3-5/15.9.4 and supplemented by an automatic heading control is to be confirmed to be functioning satisfactorily.

3.1.8 Manual Thruster Control System

In addition to 7-9-6/3.1.3 through 7-9-6/3.1.6, the operation of the manual thruster control system using individual levers on the Navigation Bridge or DP control station in accordance with 4/9.5 of the *ABS Guide for Dynamic Positioning Systems* is to be confirmed to be functioning satisfactorily.

3.1.9 Alarms and Instrumentation

The following audible and visual alarms including indicators at each control station are to be examined, verified operational and confirmed to be functioning satisfactorily, as applicable:

Thruster Power System

- i) Engine lubricating oil pressure – low*
- ii) Engine coolant temperature – high*
- iii) CPP hydraulic oil pressure – low and high*
- iv) CPP hydraulic oil temperature – high*
- v) CPP pitch**
- vi) Thruster RPM**
- vii) Thruster direction**
- viii) Thruster motor/semiconductor converter coolant leakage*
- ix) Thruster motor/semiconductor converter temperature**
- x) Thrust motor short circuit**
- xi) Thruster motor exciter power available**
- xii) Thruster motor supply power available**
- xiii) Thruster motor overload*
- xiv) Thruster motor high temperature*

Power Distribution System

- i) Status of automatically controlled circuit breakers**
- ii) Bus bar current and power levels**
- iii) High power consumers – current levels**

System Performance

- i) Excursion outside operating envelope*
- ii) Control system fault*
- iii) Position sensor fault*
- iv) Vessel target and present position and heading**
- v) Wind speed and direction**
- vi) Selected reference system**

*In addition, for **DPS-2** and **DPS-3** notations*

- i) Thruster location (pictorial)**
- ii) Percentage thrust**
- iii) Available thrusters on stand-by**
- iv) DP alert through consequence analyzer*
- v) Position information of individual position reference systems connected**

* Alarm

** Display

3.1.10 Uninterruptible Power Systems (UPS) (1 July 2013)

The uninterruptible power systems (UPS) are to be operated and confirmed to be functioning satisfactorily. The uninterruptible power systems (UPS) are to be operated without the normal main power input for 30 minutes to confirm that the batteries are capable of supplying the output power and are in satisfactory condition. The schedule of batteries is to be examined to verify that the batteries have been maintained. See 7-6-2/1.1.8(d).

3.1.11 Communication

- i) A means of voice communication between the DP control position (navigation bridge), and the thruster room(s) is to be tested and confirmed to be functioning satisfactorily.
- ii) A means of voice communication between the DP control position (Navigation Bridge), the engine control position and any operational control centers associated with DP is to be tested and confirmed to be functioning satisfactorily.

Note: No back up required.

3.1.12 Dynamic Positioning System (1 July 2013)

- i) Confirmation of dynamic positioning system operations manual onboard. Verification that the manual is up to date with any modifications performed on the installation.
- ii) Verification that the failure modes and effects of any modifications or upgrades have been considered and incorporated in the operations manual.
- iii) **Fail Safe Tests for Thrusters.** A single fault in the thruster system is to be such that a thruster fails to a safe mode so that the vessel's position and heading are not affected. Fail to a safe mode could be a failure to zero thrust or motor stop.

3.3 First Drydocking Survey After Delivery (2007)

At the first drydocking survey after delivery, thruster units are to be examined and confirmed in satisfactory condition including the following.

- i) External examination including propeller, gear housing, bolting and their securing arrangements and for seal leakage.
- ii) Internal gear train examination through inspection opening. Where inspection opening is not provided, at least one unit is to be opened for examination.
- iii) Lubrication oil sample analysis.
- iv) In addition, for controllable pitch propellers, blade seal leak check and functional test.

Where deemed necessary by the Surveyor, nondestructive testing may be required.

In case the first drydocking survey after delivery is the first Special Periodical Survey after delivery, 7-9-6/3.5 will apply and in addition, 7-9-6/3.3ii) is to be carried out.

3.5 Special Surveys (2017)

In addition to the requirements of the Annual Survey, complete performance tests are to be carried out to the Surveyor's satisfaction. The schedule of these tests is to be designed to demonstrate the level of redundancy established in the FMEA (Failure Modes and Effects Analysis, see Subsection 2/11 of the *ABS Guide for Dynamic Positioning Systems*) for **DPS-2** and **DPS-3**. See Subsection 7/5 of the *ABS Guide for Dynamic Positioning Systems*. **In those cases where a Continuous DP Testing Program has been accepted in 7-9-6/3.5.1, this may be considered by the Surveyor for acceptance in lieu of conducting the complete performance test.**

- i) Thrusters are to be surveyed as part of the Special Periodical Survey in accordance with 7-9-6/1.3.
- ii) Full power tests of thrusters and generators are to be conducted

3.5.1 Annual DP Testing Program

If the vessel is on Continuous Survey Machinery, the Owner may submit a Continuous DP Testing Program to conduct the required FMEA and performance testing throughout the survey cycle. The program may schedule approximately 20% of the FMEA and performance testing, along with the requirements of 7-9-6/3.1 for the Annual Survey each year. This Annual DP Testing Program shall be submitted for review to ABS. The testing program shall be kept on board the vessel for reference at each Annual Survey.

PART
7

CHAPTER 9 Survey Requirements for Additional Systems and Services

SECTION 7 Vapor Emission Control System

1 VEC Notation

1.1 Annual Surveys

In order to retain the **VEC** notation, at each Annual Survey, the vapor emission control system is to be generally examined in so far as can be seen, and placed in satisfactory condition. The survey is also to include:

1.1.1 Components and Piping

External examination of all components and piping, including isolating/relief valves, means of collecting and draining condensate, means for separation of vapors from non-compatible cargoes and electrical continuity/bonding arrangements.

1.1.2 Manifold Isolating Valve

Confirmation of the proper operation of the vapor manifold isolating valve, including manual operation.

1.1.3 Vapor Connection Flanges

Confirmation of the continuing effectiveness of the “lug and hole” construction of the vapor connection flange(s), or other approved means of preventing misconnection of the loading hose to the vapor collection system.

1.1.4 Hoses

Confirmation that any hoses used for the conveyance of vapor are in accordance with SVR 5C-1-7/21.9.4.

1.1.5 Inert Gas piping

Where inert gas distribution piping is used for vapor collection, confirmation of the continuing effectiveness of the inert gas main isolating valve(s).

1.1.6 Cargo Gauging System

Correct operation of the closed cargo gauging system for each tank which is connected to the vapor collection system. Where portable gauging devices are used, the number of devices available shall be equal to the number of tanks that can be simultaneously loaded plus two (2) additional units.

1.1.7 Cargo Tank Venting System

Examination of the cargo tank venting system, including flame screens, where fitted.

1.1.8 Alarms and Safety Devices

Verification of the satisfactory operation of the following alarms and safety devices using simulated conditions, where necessary:

- High vapor pressure in main vapor collection line(s) (not required for tank barges).
- Low vapor pressure in main vapor collection line(s) (not required for tank barges).
- Cargo tank high liquid level.
- Cargo tank overfill (high-high liquid level).
- Loss of power to alarm system or, alternatively, failure of tank level sensor circuitry.
- Automatic shutdown system (where fitted).

1.1.9 Operation and Maintenance Records

The Surveyor is to examine the permanent records to verify the operation and maintenance of the system. Consideration may be given by the Surveyor for the crediting of certain items that have been properly documented and recorded.

1.3 Special Periodical Surveys

In order to retain the **VEC** notation, at each Special Periodical Survey, the following items of the vapor emission control system are to be examined and placed in satisfactory condition:

1.3.1 Valves

All valves, including cargo tank isolating valves, main vapor line cross-over valves (where fitted for vapor segregation), condensate drain valves, manifold isolating valves, pressure/ vacuum relief valves and spill valves/rupture disks (where fitted as additional overfill control devices) are to be examined.

1.3.2 Gauging System

The closed gauging system, including portable gauging devices where applicable, is to be examined.

1.3.3 Alarms

The independent cargo tank overfill alarms are to be examined.

1.3.4 Hoses

Vapor collection system hoses are to be tested for electrical continuity or non-conductivity, as applicable.

1.3.5 Inert Gas Piping

Where inert gas distribution piping is used for vapor collection, deck seals or double block and bleed assemblies are to be examined.

3 VEC-L Notation

3.1 Annual Surveys

In order to retain the **VEC-L** notation, at each Annual Survey, in addition to the requirements of 7-9-7/1.1, the following items of the vapor emission control system are to be examined and placed in satisfactory condition:

3.1.1 Detonation Flame Arrester

Confirmation that the Detonation Flame Arrester (where fitted) is in satisfactory condition.

3.1.2 Vapor Manifold

Confirmation that a means of electrical insulation (insulating flange or non-conductive hose, etc.) is provided for the vapor manifold connection.

3.1.3 Fixed Oxygen Analyzer

Confirmation of the accuracy of the fixed oxygen analyzer (required to be fitted within 3 meters (10 feet) of the vessel's vapor manifold connection) by means of a calibration gas.

3.1.4 Vapor Blowers/Compressors

General examination of any devices (such as compressors or blowers) used to increase the vapor flow rate.

3.3 Special Periodical Surveys

In order to retain the **VEC-L** notation, at each Special Periodical Survey, in addition to the requirements of 7-9-7/3.1, the following items of the vapor emission control system are to be examined and placed in satisfactory condition:

3.3.1 Vapor Blowers/Compressors and Detonation Flame Arresters

For tank vessels designated by the notation **VEC-L**, Vapor blowers/compressors and detonation flame arresters, where fitted, are to be examined, including isolating and relief valves, as applicable.

PART
7

CHAPTER 9 Survey Requirements for Additional Systems and Services

SECTION 8 Fire Fighting Service

1 FFV Class 1, FFV Class 2 and FFV Class 3 Notation

1.1 Annual Surveys for Fire Fighting Vessels

1.1.1 General

At each Annual Survey, in addition to surveys of hull, machinery and equipment otherwise required by the Rules, the fire fighting equipment onboard the vessel is to be verified operational in accordance with the operating booklet and safety plan and to the satisfaction of the attending Surveyor.

Compliance with the periodic maintenance program and operating booklet is to be verified by the Surveyor.

1.1.2 Fire Fighting Systems

The fire fighting equipment to be verified in operating condition is to include the following:

- Water Monitors including controls.
- Pumps and piping for water monitors and water spray.
- Sea Suctions (strainer plates, valves).
- Hose Stations.

1.1.3 Special Equipment

The following special equipment is to be verified to be in operating condition:

- Fireman's outfits.
- Searchlights.
- Recharging Equipment.

3 FFV Class 1 Notation

3.1 Annual Surveys for Fire Fighting Vessels

3.1.1 Fixed Water-Spray System

In addition to the requirements of 7-9-8/1.1, the Annual Survey is to include an operational test of the fixed water-spray system, including spray system pumps and deck drainage arrangements.

5 FFV Class 2 Notation

5.1 Annual Surveys for Fire Fighting Vessels

5.1.1 Fire Fighting Systems

In addition to the requirements of 7-9-8/1.1, the Annual Survey is to include the following:

- Mobile high expansion foam generators are to be verified to be in operating condition.
- Verification by the Surveyor that the renewal of the foam forming liquid has been carried out in accordance with the replacement schedules, which is included in the operating booklet. Generally, foam renewal is to be carried out every 36 months.
- Examination of the deadlights and shutters if the vessel is not fitted with a fixed water-spray system.

7 FFV Class 3 Notation

7.1 Annual Surveys for Fire Fighting Vessels

7.1.1 Fire Fighting Systems

In addition to the requirements of 7-9-8/5.1.1, the Annual Survey of the fixed foam monitor system is to be verified to be in operating condition.

PART
7

CHAPTER 9 Survey Requirements for Additional Systems and Services

SECTION 9 Safety Standby Service

1 Safety Standby Service Notation

1.1 Annual Surveys and Surveys after Each Rescue Operation or Evacuation (2005)

At each Annual Survey, in addition to surveys of hull, machinery and equipment and after each Rescue Operation or Evacuation, the rescue equipment, safety equipment, arrangement, accommodation and assigned freeboard marks are to be examined and placed in satisfactory condition to the satisfaction of the attending Surveyor. The survey is also to include the following, as applicable:

1.1.1 Windows

Confirmation that bridge front windows and those of forward end of bridge sides are provided with efficient means of being blanked off.

1.1.2 Rescue Zones

1.1.2(a) Confirmation that bulwarks or railings in rescue zone are provided with gates or chains and readily operable or removable.

1.1.2(b) Arrangements provided for deploying boarding nets and for attachment of lifelines.

1.1.2(c) Confirmation that Rescue Zones (and reception area) are illuminated and marked so as to be readily identified from seaward and generally free of hull fittings and projections and overboard discharges which would impede the rescue operations.

1.1.3 Recovery from the Sea

System to aid access up ship's side from the sea or from rescue boat alongside, and power assisted method of recovering injured persons from the sea, are to be confirmed in satisfactory operating condition.

1.1.4 Load Line

Load line marks are to be verified.

1.1.5 Accommodations for Survivors

Spaces provided for shelter of survivors, including heating, lighting and ventilation arrangements, seating and berthing arrangements and sanitary facilities, are to be generally examined and confirmed in satisfactory condition.

1.1.6 Rescue and Safety Equipment

Rescue and safety equipment, including the following, as applicable, is to be examined and confirmed in satisfactory operating condition.

- Rescue boats and launching arrangements
- Rescue net at each rescue zone
- Searchlights
- Water spraying system

- Gas detection equipment
- Person overboard alarm
- Main and emergency lighting for rescue operation
- Helicopter winching area
- Arrangements for towing liferafts and lifeboats
- Survival suits
- Life rings
- Lifebuoys
- Safety harness and line with safety hook
- Line thrower with accessories and lines
- Diver's ladders.
- Life jackets

1.1.7 Navigational Equipment

Navigational equipment, including radio direction-finder and radio homing equipment, are to be examined and confirmed in satisfactory operating condition.

1.1.8 Radio and Communications Equipment

Radio and communication equipment, including the following, is to be examined and confirmed in satisfactory operating condition.

- Single sideband radiotelephone station
- Maritime VHF radiotelephone station
- VHF radio telephone with helicopter communications frequencies
- Helicopter beacon
- Daylight signaling lamp
- Two (2) transistorized portable loud hailers
- Portable waterproof VHF radiotelephones for each rescue boat and for each rescue zone

1.1.9 Medical Stores (2005)

Verification that the inspection of medical stores has been carried out every 6 months and after each rescue operation or evacuation by a licensed pharmacist.

PART
7

CHAPTER 9 Survey Requirements for Additional Systems and Services

SECTION 10 Offshore Installations Support Service (2004)

1 Offshore Support Vessel Notation

1.1 Annual Surveys for Offshore Support Vessels

1.1.1 General

At each Annual Survey, in addition to surveys of hull, machinery and equipment otherwise required by the Rules, the following features, as applicable, are to be examined and placed in satisfactory condition to the satisfaction of the attending Surveyor.

- Arrangement of fender
- Cargo deck covering
- Cargo rail

1.1.2 Liquid Cargo Tank

Where tanks for hazardous and noxious liquid cargo are fitted, the survey requirements for Chemical Carriers are applicable.

1.3 Annual Surveys for Anchor Handling/Offshore Support Vessels (2011)

In addition to the requirements of 7-9-10/1.1, the Annual Survey is to include the following:

- Winch and accessories for anchor handling are to be examined and placed in satisfactory condition.
- Where A-frame or shear leg type crane is installed for anchor handling, they are to be examined in compliance with the *ABS Guide for Certification of Lifting Appliances*.
- Stern roller arrangements are to be examined and placed in satisfactory condition.

1.5 Annual Surveys for Well Stimulation/Offshore Support Vessels

In addition to the requirements of 7-9-10/1.1, the Annual Survey is to include the following:

- Acid spill protection arrangements, lining or coating of decks, spray shield for pipe connections, drip trays and drainage arrangements are to be examined and placed in satisfactory condition.

3 Vessels with SPS Notation (2016)

3.1 Annual Surveys

At each Annual Survey, in addition to the surveys of hull, machinery and equipment otherwise required by the Rules, the following features, as applicable, are to be examined to the satisfaction of the attending Surveyor.

- i) The Surveyor is to verify that the vessel remains in compliance with the SPS Code, and maintains valid SOLAS Cargo Ship or Passenger Ship Certificates appropriate for the number of special personnel carried.

5 Offshore Supply Notation (2016)

5.1 Annual Surveys

At each Annual Survey, in addition to the surveys of hull, machinery and equipment otherwise required by the Rules, the following features, as applicable, are to be examined to the satisfaction of the attending Surveyor.

- i) Safe havens and escape routes are to be marked on the deck.
- ii) Cargo piping
- iii) All remote shutdowns of liquid cargo pumps are to be tested.
- iv) Spill coamings are to be inspected.
- v) Liquid mud cargo tanks are to have vent pipes with burst disc(s) rated below the mud tank design pressure.
- vi) Spare burst discs are to be verified on board.
- vii) Cargo hoses are to have a burst pressure not less than 5 times the expected service pressure.
- viii) Cargo hoses for combustible service have electrical conductivity and are to be earthed.
- ix) Transfer hoses operating in excess of 725 psi pressure are to have emergency depressurization and disconnection.
- x) Emergency means for disconnection of the cargo hoses are to be provided and capable of being activated from the Dynamic Positioning or Cargo Control Station. The disconnection is to be self-sealing (automatic closing).
- xi) Steering gear must be capable of moving from 35 degrees on either side (Port or Stbd) to 30 degrees on the opposite side in 20 seconds. For testing, the vessel does not need to be underway. This requirement does not apply to vessels with **DP** notation.

5.3 Special Surveys

In addition to the requirements listed above for annual survey, the below is required.

- i) Cargo hoses are to be hydrostatically tested.
- ii) Cargo transfer hose emergency disconnect capabilities are to be demonstrated.

7 Vessels with the Supply HNLS Notation (2016)

7.1 Annual Surveys

At each Annual Survey, in addition to the surveys of hull, machinery and equipment otherwise required by the Rules, the following features, as applicable, are to be examined to the satisfaction of the attending Surveyor.

7.1.1 Hull

- i) Requirements of IMO Resolution A 673(16) were verified
- ii) Special requirements listed in Section 5-2-3 of the *ABS Rules for Building and Classing Offshore Support Vessels (OSV Rules)* for the types of cargo capable of being carried are complied with based on the approved cargo list.
- iii) Acid spill protection equipment is to be provided.
- iv) Decontamination (showers and eye washes) and protective safety equipment provided.

7.1.2 Other

Special requirements for the following are to be complied with as required:

- i)* Electrical equipment in hazardous areas
- ii)* Tank venting arrangements
- iii)* Cargo control, monitoring, safety devices and shut downs
- iv)* Access and ventilation for hazardous areas
- v)* Loading and discharging connections
- vi)* P/V valves on tanks
- vii)* Fire fighting systems and equipment
- viii)* Vapor detection and portable gas detectors (2)
- ix)* Special requirements for liquefied gases

7.3 Special Surveys

- i)* P/V valves are to be disassembled, internally examined and function tested upon reassembly.

9 Vessels with the AH, TOW, and AH, TOW Notations (2016)

9.1 Annual Surveys

At each Annual Survey, in addition to the surveys of hull, machinery and equipment otherwise required by the Rules, the following features, as applicable, are to be examined to the satisfaction of the attending Surveyor.

9.1.1 Hull

- i)* Cargo rails, safe havens, escape routes, and control stations

9.1.2 Machinery

- i)* It is to be confirmed that towing winch brakes are to be applied upon loss of power.
- ii)* Drum Overload Clutch is to be inspected where fitted.
- iii)* Pad eyes used for securing anchors and chains are to be marked with their respective SWL.
- iv)* Steering gears must be proven to operate from 35 degrees on either side (Port or Stbd) to 30 degrees on the opposite side in 20 seconds. For testing purposes, the vessel need not be underway. This requirement does not apply to vessels with **DP** notation.
- v)* Anchor Handling A-frame shear leg cranes are to be part of the ABS Cargo Gear Register.
- vi)* Function test and general examination of the tow winch, towing pins, towing eyes, shark jaws and stern roller, as applicable.

9.3 Special Surveys

- i)* Drum Overload Clutch is to be tested where fitted.
- ii)* Quick Release Devices to be tested where fitted.

11 Vessels with the ROV Notation (2016)

11.1 Annual Surveys

At each Annual Survey, in addition to the surveys of hull, machinery and equipment otherwise required by the Rules, the following features, as applicable, are to be examined to the satisfaction of the attending Surveyor.

- i) ROVs and their associated support systems (handling systems, control stations, etc.) installed on the vessel are to be classed by ABS or another IACS member.
- ii) The vessel is to have a position keeping capability, which may be achieved with either a **DPS-2**, **DPS-3** installation, or a mooring system which is in operational condition. To retain the **ROV** notation the position keeping capability of the vessel must be maintained.
- iii) The ROV handling system is to be in accordance with Section 16 of the *ABS Rules for Building and Classing Underwater Vehicles, Systems and Hyperbaric Facilities (Underwater Vehicles Rules)*, or in accordance with the IACS Society that Classed the ROV system, and arranged to minimize interference with the vessels propellers, thrusters, or anchors.
- iv) The handling system and support components are to be welded or bolted to the hull. These connection points are to be inspected to the satisfaction of the attending surveyor. Lashing is not an acceptable means of securing.
- v) The ROV control station is provided with communications to the vessel's control stations and all other control stations for subsea equipment.
- vi) All vessel and ROV interfaces are to be tested.

13 Vessels with the ROV Capable and DSV Capable Notations (2016)

13.1 Annual Surveys

At each Annual Survey, in addition to the surveys of hull, machinery and equipment otherwise required by the Rules, the following features, as applicable, are to be examined to the satisfaction of the attending Surveyor.

Equipment and arrangements, including any applicable Class Notations, stipulated by ABS as being required to support the vessel's capability notation as reflected in the *Record* are to be verified.

15 Vessels with the DSV Notation (2016)

15.1 Annual Surveys

At each Annual Survey, in addition to the surveys of hull, machinery and equipment otherwise required by the Rules, the following features, as applicable, are to be examined to the satisfaction of the attending Surveyor.

- i) The dive system was confirmed to have been classed by ABS or another IACS society.
- ii) The vessel has a position keeping capability, either with a **DPS-2**, **DPS-3** installation, or a mooring system which is in operational condition.
- iii) Breathing gas is to be stored in accordance with 5-5-3/3 of the *OSV Rules*.
 - a) Breathing gas with more than 25% Oxygen is stored on deck or in a space with at least two Oxygen analyzers with audio-visual alarms with one located in the upper and one in the lower level of the enclosed space.
 - b) Enclosed Oxygen storage spaces do not have any hydrocarbons, fat, grease, or other flammable material stored or present in them.
- iv) The diving system is welded or bolted to the hull. The means of securing allows for pressure expansion.

- v) Piping systems carrying gases under high pressure are not in accommodation spaces, engine rooms, or similar compartments. Piping systems carrying flammable fluids are not run through open deck areas or spaces housing breathing gases.
- vi) An emergency generator (either the vessel's or a dedicated dive system generator) is available for safe termination of the diving operation.
- vii) The emergency source of power is located outside the machinery spaces and as far away as is practicable from the normal source of power for the diving system.
- viii) Diving systems and systems installed in enclosed spaces including:
 - a) A-60 Boundaries when adjacent to Category A machinery spaces
 - b) Fixed fire fighting systems, means of cooling PVHO windows, and portable extinguishers
 - c) Means of cooling breathing gas cylinders/pressure vessels
 - d) Automatic fire detections or monitoring system with alarms panels
- ix) Diving systems on deck are to have suitable fire fighting capabilities including means of cooling PVHO windows.
- x) Automatic Fire Detection or monitoring at the dive control station is provided for systems on open deck.
- xi) Dive control stations for permanent installations are installed in accordance with the ABS *Underwater Vehicles Rules*, or in accordance with the requirements of the IACS member that Classed the diving system.
- xii) Portable dive control stations are located and have communications in accordance with 5-5-3/19.3 and 5-5-3/19.5 of the *OSV Rules*.
- xiii) All vessel and ROV interfaces are to be tested.
- xiv) All vessel and Dive System interfaces are to be tested.

17 Vessels with the Pipe Lay Notation (2016)

17.1 Annual Surveys

At each Annual Survey, in addition to the surveys of hull, machinery and equipment otherwise required by the Rules, the following features, as applicable, are to be examined to the satisfaction of the attending Surveyor.

- i) The vessel has a mooring system in accordance with **M** or **P** if moored, or a dynamic positioning system in accordance with **DPS-2** or **DPS-3**.
- ii) Cranes fitted on the vessel are certified by ABS in accordance with the ABS *Guide for Certification of Lifting Appliances (Lifting Appliance Guide)*.
- iii) The pipe laying control station has a clear view of the pipe departure location and provides an overview of all systems and activities associated with pipe laying operations.
- iv) The pipe laying control station has a hard wired communication system and manually operated alarm system with the vessel's station keeping station.
- v) The pipe laying control station has a means of communication with the local control stations for the pipe laying equipment.
- vi) The following items have been examined and found to be in accordance with the applicable rules as noted:
 - a) Abandonment and Recovery System
 - b) Reels, carousels, pipe racks and support structure
 - c) Pipe laying towers and skid frames

- d) Pipe tensioners
- e) Hang off clamps (means to hold the pipe in case of blackout)
- f) Control stations and remote control stations for tensioners
- g) Any ROV handling systems and control stations are in accordance with Sections 16 and 17 of the *Underwater Vehicles Rules*, and secured in accordance with 5-5-3/5 of the *OSV Rules*.

17.3 Special Surveys

- i) A functional test of the pipe laying system on board to the extent and per the agreed method
- ii) Verification of the positioning system is completed to the satisfaction of the attending Surveyor

19 Vessel with the Heavy Lift Notation (2016)

19.1 Annual Surveys

At each Annual Survey, in addition to the surveys of hull, machinery and equipment otherwise required by the Rules, the following features, as applicable, are to be examined to the satisfaction of the attending Surveyor.

- i) The vessel has a mooring system in accordance with **Ⓟ** if moored, or a dynamic positioning system in accordance with **DPS-2** or **DPS-3** and have been tested and found satisfactory.
- ii) Any crane permanently installed on board the crane unit and intended for operations other than supply of provisions and maintenance of the unit is to be certified by ABS in accordance with Chapter 2 of the *ABS Lifting Appliance Guide* or API Spec. 2C.
- iii) Cranes used for subsea lifting have been certified and tested in accordance with Appendix 5-9-A2 of the *ABS OSV Rules*.
- iv) The crane's power system is in accordance with 5-9-3/9.1 of the *ABS OSV Rules*.
- v) The vessel's heeling and ballasting system is to be operationally tested to the satisfaction of the attending Surveyor.
- vi) Crane controls
- vii) The crane operator's control station has hard wired communications with the vessel's station keeping station.
- viii) The vessel has all the crane manuals accessible on board which contain the operational limits, system diagrams, materials, welding procedures, NDE, maintenance, and inspection requirements.
- ix) A record of the crane tests and other information concerning initial certification is to be readily available.

21 Vessels with the Escort or QR Notation (2016)

21.1 Annual Surveys

At each Annual Survey, in addition to the surveys of hull, machinery and equipment otherwise required by the Rules, the following features, as applicable, are to be examined to the satisfaction of the attending Surveyor.

- i) Operational testing of the tow winch is required
- ii) Verify that the vessel's fendering arrangement is in accordance with the approved drawing

21.3 Special Surveys

- i) Functional testing of the quick release devices is required.

23 Vessels with the WIND-IMR Notation (2016)

23.1 Annual Surveys

At each Annual Survey, in addition to the surveys of hull, machinery and equipment otherwise required by the Rules, the following features, as applicable, are to be examined to the satisfaction of the attending Surveyor.

- i) Cranes are in accordance with API Spec 2C or the ABS *Lifting Appliance Guide*.
- ii) Any mobile cranes are capable of being secured. Securing arrangements are to be demonstrated. Foundations of machinery examined.
- iii) Dynamic positioning systems are in accordance with **DP** notation requirements where fitted.
- iv) Jacking systems if fitted are examined in accordance with the requirements of the 7-2-4/1.7 of the ABS *MODU Rules*.
- v) A record of the crane tests and other information concerning initial certification is to be readily available.

25 Vessels with the Cable Lay Notation (2016)

25.1 Annual Surveys

At each Annual Survey, in addition to the surveys of hull, machinery and equipment otherwise required by the Rules, the following features, as applicable, are to be examined to the satisfaction of the attending Surveyor.

- i) Vessel's position keeping system to be examined, in accordance with **DPS-2**, **DPS-3**, **Ⓟ**, or **Ⓜ**, as applicable.
- ii) Cranes are to be certified in accordance with the *Lifting Appliance Guide*.
- iii) Foundations of cable laying machinery examined for soundness.
- iv) Central control station examined, hard wired communications, and manual alarms verified.
- v) Cable drums, reels, and deployment structures examined.
- vi) Work-class ROVs found with a handling system and control station examined for compliance with Sections 16 and 17 of the *Underwater Vehicles Rules*.
- vii) Dynamic tracking system examined for reliable interface with vessel's data and control networks.
- viii) Cable laying system emergency stops satisfactorily tested.

27 Vessels with the WI Notation (2016)

27.1 Annual Surveys

At each Annual Survey, in addition to the surveys of hull, machinery and equipment otherwise required by the Rules, the following features, as applicable, are to be examined to the satisfaction of the attending Surveyor.

- i) For subsea well intervention systems confirm well control is only possible from the well intervention vessel as accessible and two upstream pressure containing barriers are present.
- ii) The riserless well intervention system is in accordance with the approved drawing, is ABS certified, has a pressure control head, and a BOP section including emergency disconnect.
- iii) The riserless well intervention well control system and components are certified by ABS in accordance with the *OSV Rules* and applicable sections of the ABS *Guide for Certification of Drilling Systems (CDS Guide)*.
- iv) Maintenance, testing and overhaul of the Well Intervention system were verified to be in accordance with the *CDS Guide* and considered satisfactory.

27.3 Special Surveys

- i) Maintenance, testing and overhaul of the Well Intervention system were verified to be in accordance with the *CDS Guide* requirements for special survey and considered satisfactory.

29 Vessels with in the WI-Ready Notation (2016)

29.1 Annual Surveys

At each Annual Survey, in addition to the surveys of hull, machinery and equipment otherwise required by the Rules, the following features, as applicable, are to be examined to the satisfaction of the attending Surveyor.

- i) Cranes are in accordance with API Spec 2C or the ABS *Lifting Appliance Guide*. Interventions accessing wellbore are to have suitable heave compensation similar to Appendix 5-9-A2 of the ABS *OSV Rules*.
- ii) Equipment and arrangements, including any applicable Class Notations, stipulated by ABS as being required to support the vessel's **WI-Ready** notation as reflected in the *Record* are to be verified.
- iii) Any permanently mounted well intervention equipment installed on board the vessel is to be tested in accordance with Section 5-10-4 of the ABS *OSV Rules*.

31 Vessels with the WI-Temp Notation (2016)

31.1 Annual Surveys

At each Annual Survey, in addition to the surveys of hull, machinery and equipment otherwise required by the Rules, the following features, as applicable, are to be examined to the satisfaction of the attending Surveyor.

- i) If well intervention equipment is installed on board on a temporary basis, surveys are to be conducted in accordance with 7-9-10/27.

33 Well Intervention Vessels with no Specific Notation (2016)

33.1 Annual Surveys

At each Annual Survey, in addition to the surveys of hull, machinery and equipment otherwise required by the Rules, the following features, as applicable, are to be examined to the satisfaction of the attending Surveyor.

- i) The vessel has a mooring system in accordance with **Ⓟ** if moored, or a dynamic positioning system in accordance with **DPS-2** or **DPS-3** and have been tested and found satisfactory.
- ii) Cranes are in accordance with API Spec 2C or the ABS *Lifting Appliance Guide*.
- iii) Interventions accessing wellbore are to have suitable heave compensation similar to Appendix 5-9-A2 of the ABS *OSV Rules*.
- iv) Confirm that no changes have been made to hazardous areas as defined in accordance with Section 6.2 of the IMO MODU Code.
- v) The system is set up and capable of being operated safely within the operational window, with provisions for fire fighting, communications, adequate access to controls, and escape.
 - a) Flammable and hydrogen sulfide gas detection has been tested, along with automatic shutdown functions when required.
 - b) Safety systems monitoring system flow rate, pressure, liquid level and temperature with alarms for abnormal conditions are fitted.
 - c) At least one panel is fitted capable of closing all elements of BOP and disconnecting subsea connector is provided at a safe and readily accessible location.
 - d) The safety systems are to be provided with and powered by a UPS for 30 minutes on both main and emergency circuits. If hydraulic or pneumatic, power is to be supplied from main and emergency sources, or dedicated well intervention power plant.

35 OSV Well Stimulation Vessels with no Class Notation (2016)

35.1 Annual Surveys

At each Annual Survey, in addition to the surveys of hull, machinery and equipment otherwise required by the Rules, the following features, as applicable, are to be examined to the satisfaction of the attending Surveyor.

- i) The vessel has a mooring system in accordance with **Ⓟ** if moored, or a dynamic positioning system in accordance with **DPS-2** or **DPS-3** and have been tested in accordance with 5-11-6/3 of the *OSV Rules*.
- ii) Special arrangements for remote controls, low flashpoint liquids, and tank venting must be opened out and tested as necessary.
- iii) Portable tanks are to be in accordance with 5-2-3/9.9.2 of the *OSV Rules*.
- iv) Acid and liquid nitrogen systems are to be in accordance with Section 5-11-4 of the *OSV Rules*.
- v) Shutdowns as required by 5-11-7/3vii) of the *OSV Rules* verified, along with gas detection, oxygen monitoring, tank gauging and alarm systems, communications and power supplies.
- vi) Decontamination showers, eyewashes, protective safety equipment, and fire fighting systems verified in accordance with Section 5-11-5 of the *OSV Rules*.

37 Vessels with the WS-Ready Notation (2016)

37.1 Annual Surveys

At each Annual Survey, in addition to the surveys of hull, machinery and equipment otherwise required by the Rules, the following features, as applicable, are to be examined to the satisfaction of the attending Surveyor.

In addition to all the requirements for vessels with no well stimulation notation:

- i) Permanently mounted equipment must meet the requirements for the **WS-Ready** notation as fitted.
- ii) Equipment and arrangements including any applicable Class Notations, stipulated by ABS as being required to support the vessel's **WS-Ready** notation as reflected in the *Record* are to be verified.

39 Vessels with the WS-Temp Notation (2016)

39.1 Annual Surveys

At each Annual Survey, in addition to the surveys of hull, machinery and equipment otherwise required by the Rules, the following features, as applicable, are to be examined to the satisfaction of the attending Surveyor.

In addition to all the requirements for vessels with no well stimulation notation:

- i) Well control systems and components are to be tested in accordance with the *CDS Guide* for annual survey requirements as applicable.

41 Vessels with the WS Notation (2016)

41.1 Annual Surveys

At each Annual Survey, in addition to the surveys of hull, machinery and equipment otherwise required by the Rules, the following features, as applicable, are to be examined to the satisfaction of the attending Surveyor.

In addition to all requirements for the **WS-TEMP** notation:

- i) Special arrangements for ventilation, acid spill and liquid nitrogen protection are to be examined.

43 Vessels with Well Test Systems with no Notation (2016)

43.1 Annual Surveys

At each Annual Survey, in addition to the surveys of hull, machinery and equipment otherwise required by the Rules, the following features, as applicable, are to be examined to the satisfaction of the attending Surveyor.

Hazardous areas are to be compliance with API 500 or 505.

- i) The following safety systems are to be in accordance with API 14C:
 - a) Process monitoring
 - b) Flammable gas detection
 - c) H₂S detection
 - d) Fire fighting equipment
- ii) The vessel has a mooring system in accordance with **Ⓟ** if moored, or a dynamic positioning system in accordance with **DPS-2** or **DPS-3** and have been tested and found satisfactory. See 5-12-2/3 of the *ABS OSV Rules*.
- iii) Special requirements for structural fire protection, and water supply for fire fighting of the vessel have been examined.

45 Vessels with the WT-Ready and WT-Temp Notations (2016)

45.1 Annual Surveys

At each Annual Survey, in addition to the surveys of hull, machinery and equipment otherwise required by the Rules, the following features, as applicable, are to be examined to the satisfaction of the attending Surveyor.

- i) Equipment and arrangements, including any applicable Class Notations, stipulated by ABS as being required to support the vessel's **WT-Ready** notation as reflected in the *Record* are to be verified.
- ii) The vessel maintains a mooring system in accordance with **Ⓟ** if moored, or a dynamic positioning system in accordance with **DPS-2** or **DPS-3**.
- iii) Cranes are in accordance with API Spec 2C or the *ABS Lifting Appliance Guide*.
- iv) Interventions accessing wellbore are to have suitable heave compensation similar to Appendix 5-9-A2 of the *ABS OSV Rules*.
- v) The following items are to be examined, where fitted:
 - a) Special arrangements for structural fire protection and fire fighting are to be verified.
 - b) Hazardous areas verified to be in accordance with IMO MODU Code.
 - c) The system is set up and capable of being operated safely within the operational window, with provisions for fire fighting, communications, adequate access to controls, and escape.
 - d) Flammable and hydrogen sulfide gas detection has been tested, along with automatic shutdown functions when required.
 - e) Safety systems monitoring system flow rate, pressure, liquid level and temperature with alarms for abnormal conditions are fitted.
 - f) At least one panel is fitted capable of closing all elements of BOP and disconnecting subsea connector is provided at a safe and readily accessible location.
 - g) The safety systems are to be powered by UPS for 30 minutes on both main and emergency circuits. If hydraulic or pneumatic, power is to be supplied from main and emergency sources, or dedicated well intervention power plant.
 - h) Well control equipment to be examined and tested in accordance with the *ABS Lifting Appliance Guide*.

47 Vessels with the Well Test Service Notation (2016)

47.1 Annual Surveys

At each Annual Survey, in addition to the surveys of hull, machinery and equipment otherwise required by the Rules, the following features, as applicable, are to be examined to the satisfaction of the attending Surveyor.

- i) All requirements for the **WT-TEMP** notation.
- ii) Maintenance and overhaul of the Well Test systems were confirmed to be in accordance with the *CDS Guide* and considered satisfactory.
- iii) Hydrocarbon disposal facilities are to comply with Subsections 3/13 and 4/7 of the *ABS Guide for Well Test Systems*.

PART
7

CHAPTER 9 Survey Requirements for Additional Systems and Services

SECTION 11 Oil Recovery Service (2004)

1 Oil Spill Recovery – Standby Class 1 and 2 Notation (2013)

1.1 Annual Surveys

At each Annual Survey, in addition to surveys of hull, machinery and equipment otherwise required by the Rules for Annual Survey, the survey is to include the following:

1.1.1 Class 1

The Oil Carriers requirements of 7-3-2/1.13.1 to 7-3-2/1.13.4.

1.1.2 Class 2

The Oil Carriers requirements of 7-3-2/1.13.1 to 7-3-2/1.13.2 and 7-3-2/1.13.4, if applicable.

In addition, arrangements and systems for oil recovery operation are to be generally examined and confirmed in a satisfactory condition such that they are readily available for oil recovery operation in accordance with the approved operating manual. See 5-6-1/9.1 of the *ABS Rules for Building and Classing Offshore Support Vessels*.

1.3 Special Periodical Surveys

In addition to the survey requirements of hull, machinery and equipment otherwise required by the Rules for Special Periodical Survey and the requirements of 7-9-11/1.1 above, the recovered oil storage tanks, piping within the recovered oil tanks, and recovered oil piping in other tanks are to be specially examined and tested with a head of liquid at every Special Periodical Survey.

1.5 Survey After Each Oil Recovery Operation

The vessel's hull, machinery and equipment are to be generally examined. Arrangements and systems for oil recovery operation are to be confirmed restored for normal or stand-by operation in accordance with the approved operating manual. Tanks and piping systems used for oil recovery are to be cleaned and gas freed as required.

3 Oil Spill Recovery – Capability Class 1 and 2 Notation (2013)

3.1 Annual Surveys

At each Annual Survey, in addition to surveys of hull, machinery and equipment otherwise required by the Rules for Annual Survey, the survey is to include the following:

3.1.1 Class 1

The Oil Carriers requirements of 7-3-2/1.13.1, 7-3-2/1.13.2 for fixed recovered oil piping and fixed vents to recovered oil tanks, 7-3-2/1.13.3, and 7-3-2/1.13.4, if applicable.

3.1.2 Class 2 (2014)

The Oil Carriers requirements of 7-3-2/1.13.1, 7-3-2/1.13.2 for fixed recovered oil piping and fixed vents to recovered oil tanks, and 7-3-2/1.13.4, if applicable.

In addition, arrangements and systems for oil recovery operation are to be generally examined and confirmed in a satisfactory condition such that they are readily available for oil recovery operation in accordance with the approved operating manual with particular attention to the following:

- Area in which the oil recovery equipment will be installed,
- Tanks to be used for recovered oil,
- Designation of hazardous areas, and
- Oil recovery equipment to be used, its location, and deployment and stowage procedures, if onboard.

3.3 Special Periodical Surveys

In addition to the survey requirements of hull, machinery and equipment otherwise required by the Rules for Special Periodical Survey and the requirements of 7-9-11/3.1 above, the recovered oil storage tanks and piping within the recovered oil tanks, are to be specially examined and tested with a head of liquid at every Special Periodical Survey.

3.5 Survey Before Oil Recovery Operation (2014)

Upon completion of the installation of equipment that had been stored ashore, arrangements and systems are to be generally examined and confirmed in satisfactory condition such that they are readily available for oil recovery operation in accordance with the approved operating manual.

3.7 Survey After Each Oil Recovery Operation

The vessel's hull, machinery and equipment are to be generally examined. Arrangements and systems for oil recovery operation are to be confirmed restored for normal or stand-by operation in accordance with the approved operating manual. Tanks and piping systems used for oil recovery are to be cleaned and gas freed as required.

PART

7

CHAPTER 9 Survey Requirements for Additional Systems and Services

SECTION 12 Automatic or Remote Control and Monitoring Systems for Vessels in Port (2004)

1 PORT Notation

1.1 **Annual Surveys**

At each Annual Survey, the equipment and arrangements required for the optional class notation **PORT** are to be examined and placed in satisfactory condition. The survey is also to include:

The satisfactory operation of the system is to be verified in accordance with approved test schedule to the satisfaction of the attending Surveyor.

PART
7

CHAPTER 9 Survey Requirements for Additional Systems and Services

SECTION 13 Bridge Design and Navigational Equipment/Systems (2004)

1 NBLES Notation

1.1 Annual Surveys

At each Annual Survey, the equipment and arrangements required for the optional class notation **NBLES** are to be examined and placed in satisfactory condition. The survey is also to include:

1.1.1 Operating/Technical Manual

Ready availability of the Operating/Technical manual onboard is to be confirmed.

1.1.2 Bridge's Fields of Vision

It is to be confirmed that no unapproved alterations have been made that would affect the navigation bridge visibility since the last survey.

1.1.3 Navigational Systems

Navigational systems, Propulsion engine/thruster controls, automatic telephone systems and nautical radiocommunication systems are to be confirmed in satisfactory operating condition. Additionally, subject to the discretion of the attending Surveyor, such systems may be tested in accordance with the test program as described in C25 of the *ABS Guide for Bridge Design and Navigational Equipment/Systems*.

1.1.4 Loss of Power Supply

The satisfactory operation of automatic resumption of bridge navigational equipment/systems functions is to be confirmed to the satisfaction of the attending Surveyor.

3 NIBS Notation

3.1 Annual Surveys

In addition to the requirements of 7-9-13/1.1, the Annual Survey is also to include:

3.1.1 Integrated Bridge System

Integrated bridge system and navigational systems required for **NIBS** notation are to be confirmed in satisfactory operating condition.

PART

7

CHAPTER 9 Survey Requirements for Additional Systems and Services

SECTION 14 Integrated Tug-Barge (ITB) Combinations Intended to Operate on the Great Lakes (2005)

1 DM and PM Notation

1.1 Annual Surveys

At each Annual Survey, in addition to surveys of hull, machinery and equipment otherwise required by the Rules, the following arrangements, as applicable, are to be examined and placed in satisfactory condition.

1.1.1 Tug-Barge Connection System (2006)

Connection/disconnection system is to be examined and confirmed in satisfactory working order including the following.

- Confirmation of satisfactory operation in line with operational manual/procedure
- Linkage and/or structural connection between tug and barge including supporting structure
- Hydraulic system, if fitted, to be checked for leaks
- Hinge arms
- Locking/unlocking device including functional test as far as practicable

1.1.2 Remote Anchor Drop System (2006)

Remote anchor drop system is to be examined and confirmed in satisfactory working order including the following.

- Functional test, as far as practicable, to drop anchor from pilot house
- Manual retrieving operation of anchor at windlass location on barge, if drop test carried out
- System securing device

PART
7

CHAPTER 9 Survey Requirements for Additional Systems and Services

SECTION 15 Environmental Safety (2011)

1 Environmental Safety (ES) Notation (1 July 2014)

1.1 Annual Survey

The following certification and documentation are required, as applicable, to maintain the Environmental Safety, **ES**, notation:

- The class notation **ACC** or **ACCU** must be maintained on the class certificate.
- Current MARPOL Certificates of statements of compliance with Annex I, Annex III, Annex IV, Annex V and Annex VI
- International Pollution Prevention Certificate for the Carriage of Noxious Liquid Substances in Bulk (NLS Certificate).
- Safety Management Certificate
- A contract with the ABS Rapid Response Damage Assessment (RRDA) program, or with a similar program of another IACS Member Society
- Statement of Compliance with Standard for Vapor Emission Control Systems

The following documents are to be ABS approved and onboard:

- Bilge water management plan
- Sewage management plan
- Garbage management plan
- Ballast water management plan
- Instructions and procedures addressing operation and control of NO_x exhaust gas cleaning systems
- Fuel oil management for control of the SO_x emission, including fueling management plan and procedure
- Refrigerant systems management plan

3 Environmental Protection (ENVIRO and ENVIRO+) Notations for Vessels (1 July 2014)

3.1 ENVIRO Notation

3.1.1 Annual Surveys

The following certification and documentation are required, as applicable, to maintain the Environmental Protection, **ENVIRO**, notation:

- The class notation **ACC** or **ACCU** must be maintained on the class certificate.
- Safety Management Certificate

- A contract with the ABS Rapid Response Damage Assessment (RRDA) program, or with a similar program of another IACS Member Society
- Current MARPOL Certificates or Statements of Compliance for Annex I, Annex IV, Annex V, and Annex VI.
- International Pollution Prevention Certificate for the Carriage of Noxious Liquid Substances in Bulk (NLS Certificate).
- Compliance with the requirements in the International Convention for the Control and Management of Ship's Ballast Water and Sediments, 2004
- International Anti-Fouling System Certificate

The following documents are to be ABS approved and onboard:

- Bilge water management plan
- Sewage management plan
- Garbage management plan
- Ballast water management plan
- Instructions and procedures addressing operation and control of NO_x exhaust gas cleaning systems
- Fuel oil management for control of the SO_x emission, including fueling management plan and procedure
- Instructions and procedures addressing operation and control of SO_x exhaust gas cleaning systems
- Refrigerant systems management plan

3.3 ENVIRO+ Notation

3.3.1 Annual Surveys

The following certification and documentation are required, as applicable, to receive the Environmental Protection Plus, **ENVIRO+**, notation:

- The class notation **ACC** or **ACCU** must be maintained on the class certificate.
- Safety Management Certificate
- A contract with the ABS Rapid Response Damage Assessment (RRDA) program, or with a similar program of another IACS Member Society
- Current MARPOL Certificates or Statements of Compliance for Annex I, Annex IV, Annex V, and Annex VI.
- International Pollution Prevention Certificate for the Carriage of Noxious Liquid Substances in Bulk (NLS Certificate).
- Compliance with the requirements in the International Convention for the Control and Management of Ship's Ballast Water and Sediments, 2004
- International Anti-Fouling System Certificate
- Documentation indicating relevant navigational equipment complies with criteria of Part C, *ABS Guide for Bridge Design and Navigational Equipment/Systems*
- Incinerator type approval certificate in accordance with IMO Resolution MEPC 76(40) and Resolution MEPC.93(45), Amendments to the Standard Specification for Shipboard Incinerators

The following documents are to be ABS approved and onboard:

- Bilge water management plan
- Sewage management plan

- Garbage management plan
- Ballast water management plan
- Instructions and procedures addressing operation and control of NO_x exhaust gas cleaning systems
- Fuel oil management for control of the SO_x emission, including fueling management plan and procedure
- Instructions and procedures addressing operation and control of SO_x exhaust gas cleaning systems
- Refrigerant systems management plan

PART
7

CHAPTER 9 Survey Requirements for Additional Systems and Services

SECTION 16 Crew Habitability on Ships and Workboats
(1 July 2015)

1 Annual Surveys

The following information is to be reviewed by the attending ABS Surveyor for issues that could affect the Habitability notation (**HAB**, **HAB+**, **HAB++**, **HAB(WB)**, **HAB+(WB)**, or **HAB++(WB)**).

- i) Collision and grounding reports since the previous Initial, Annual, or Special Periodical Survey, if any
- ii) Fire, repair, and damage reports since the previous Initial, Annual, or Special Periodical Survey, if any
- iii) A list of all structural or mechanical modifications to the vessel since the previous Initial, Annual or Special Periodical Survey, if any
- iv) Verification that equipment and facilities continue to be fit for purpose and are operating in accordance with the criteria stated within the *ABS Guide for Crew Habitability on Ships* or the *ABS Guide for Crew Habitability on Workboats* (referred to as “the Guide” hereinafter)

During the attending ABS Surveyor’s review of the submitted information, a determination will be made as to whether changes or alterations have taken place that could affect the Habitability notation. As a result, the vessel may be subject to the review, ambient environmental testing, and inspection requirements of the Guide.

3 Special Periodical Surveys

3.1 Survey Requirements

The Survey is to be comprised of ABS Engineering reviews, ABS Surveyor accommodation verifications, and witnessing of ambient environmental testing. The Survey will cover all applicable habitability aspects.

The following is to be submitted to ABS three (3) months prior to carrying out the ambient environmental testing:

- i) Fire, repair or damage reports since the previous Annual Survey, if any
- ii) A list of all structural or mechanical modifications to the vessel since the previous Annual Survey, if any
- iii) Drawings/arrangements of seafarer spaces, HVAC, electrical, etc. affected by alterations, if any
- iv) Copies of the approved Initial Test Plans and Test Reports
- v) Copies of Test Plans and Test Reports resulting from Annual Surveys, if any
- vi) Previous Special Periodical Survey Test Plans and Reports
- vii) Proposed Special Periodical Survey Test Plans for the current survey

The Special Periodical Survey data submittal serves three purposes. The first is to perform an ABS Engineering review of seafarer spaces against any alterations to the vessel related to the criteria in Appendix 3 of the Guide since the Initial Survey, with measurements verified by an ABS Surveyor. The second purpose is to provide a history of ambient environmental testing, as well as the Special Periodical Survey ambient environmental Test Plans for review and approval by ABS Engineering. The third is to allow scheduling of measurement verifications and ambient environmental testing by an ABS Surveyor.

A Special Periodical Survey Test Plan for each ambient environmental aspect of Habitability is to be submitted in accordance with the criteria stated below. The approved Initial Test Plans should be used as a basis for creating the Special Periodical Survey Test Plans.

For creation of the Special Periodical Survey Test Plans, Subsection 6, “Test Plan”, and Subsection 7, “Test Requirements”, of Sections 3 through 6 of the Guide specify the requirements for each ambient environmental aspect (i.e., 3/6, 3/7, 4/6, 4/7, etc.). For specifying measurement locations for the Special Periodical Survey Test Plans, the following changes to Subparagraph 7.4.1, “Selection of Spaces where Measurements are to be Conducted”, of each ambient environmental aspect of Habitability are to be followed:

- i) Measurements shall be taken in all areas affected by vessel alterations, if any. Measurements are limited to the ambient environmental aspect affected by the alteration. For example, structural changes require both whole-body vibration and noise measurements. Structural changes do not necessarily require indoor climate or lighting measurements. Changes to luminaires require lighting measurements but not whole-body vibration, noise, or indoor climate measurements.
- ii) For all ambient environmental aspects, measurements shall be taken in all worst case or problem area locations based on the requirements set forth in 7.4.1, “Selection of Spaces where Measurements are to be Conducted”, of the appropriate Section of the Guide. [For example, worst case for whole body vibration is described in 3/7.4.1i)].
- iii) For all ambient environmental aspects, measurements shall be taken in twenty-five (25) percent of crew cabins and staterooms identified in the initial Test Plans. The cabin locations must be representative of locations port, starboard, fore, amidships, and aft. Any worst case locations can be considered part of the representative sample for crew cabins and staterooms, if applicable.
- iv) For all ambient environmental aspects, measurements shall be taken where a single instance of one (1) type of a manned space exists within the vessel (e.g., bridge, radio room, officer’s mess, gymnasium, library, etc.). The worst case locations can be considered part of the single instance representative sample, if applicable.
- v) Where multiple instances of the same type space exist, a representative sample of at least twenty-five (25) percent of each type shall be selected for measurement for all ambient environmental aspects. The worst case locations are to be considered part of the representative sample, if applicable.

For all ambient environmental conditions, visual/walk-through inspections are to be conducted in accordance with Subparagraph 7.4.2 of the appropriate section of the Guide.

5 Requirements for Vessel Alterations

No alterations which affect or may affect the ship Habitability notation awarded (**HAB**, **HAB+**, **HAB++**, **HAB(WB)**, **HAB+(WB)**, or **HAB++(WB)**), including alterations to the structure, machinery, electrical systems, piping, furnishings or lighting systems, are to be made to the vessel unless plans of the proposed alterations are submitted and approved by ABS before the work of alteration is commenced. If ABS determines that the alteration will affect the ship Habitability notation, the altered vessel may be subject to the review, verification and ambient environmental testing requirements of the Guide.

PART
7

CHAPTER 9 Survey Requirements for Additional Systems and Services

SECTION 17 Comfort on Ships and Yachts (1 July 2015)

1 Annual Surveys

The following information is to be reviewed by the attending ABS Surveyor for issues that could affect the Comfort notation (**COMF**, **COMF+**, **COMF(Y)**, or **COMF+(Y)**).

- i) Collision and grounding reports since the previous Initial, Annual, or Special Periodical Survey, if any
- ii) Fire, repair, and damage reports since the previous Initial, Annual, or Special Periodical Survey, if any
- iii) A list of all structural or mechanical modifications to the vessel since the previous Initial, Annual or Special Periodical Survey, if any
- iv) Verification that equipment and facilities continue to be fit for purpose and are operating in accordance with the criteria stated within the *ABS Guide for Passenger Comfort on Ships* or the *ABS Guide for Comfort on Yachts* (referred to as “the Guide” hereinafter)

During the attending ABS Surveyor’s review of the submitted information, a determination will be made as to whether changes or alterations have taken place that could affect the Comfort notation. As a result, the vessel may be subject to the review, ambient environmental testing and inspection requirements of the Guide.

3 Special Periodical Surveys

3.1 Survey Requirements

The Survey is to be comprised of ABS Engineering reviews, ABS Surveyor accommodation verifications and witnessing of ambient environmental testing. The Survey will cover all applicable comfort aspects.

The following is to be submitted to ABS three (3) months prior to carrying out the ambient environmental testing:

- i) Fire, repair or damage reports since the previous Annual Survey, if any
- ii) A list of all structural or mechanical modifications to the vessel since the previous Annual Survey, if any
- iii) Drawings/arrangements of passenger spaces, HVAC, electrical, etc. affected by alterations, if any
- iv) Copies of the approved Initial Test Plans and Test Reports
- v) Copies of Test Plans and Test Reports resulting from Annual Surveys, if any
- vi) Previous Special Periodical Survey Test Plans and Reports
- vii) Proposed Special Periodical Survey Test Plans for the current survey

The Special Periodical Survey data submittal serves two purposes. The first purpose is to provide a history of ambient environmental testing, as well as the Special Periodical Survey ambient environmental Test Plans for review and approval by ABS Engineering. The second is to allow scheduling of the ambient environmental testing by an ABS Surveyor.

A Special Periodical Survey Test Plan for each ambient environmental aspect of Comfort is to be submitted in accordance with the criteria stated below. The approved Initial Test Plans should be used as a basis for creating the Special Periodical Survey Test Plans.

3.3 Passenger Comfort on Ships

For creation of the Special Periodical Survey Test Plans, Subsection 6, “Test Plan”, and Subsection 7, “Test Requirements”, of Sections 2 through 5 of the Guide specify the requirements for each ambient environmental aspect (i.e., 2/6, 2/7, 3/6, 3/7, etc.). For specifying measurement locations for the Special Periodical Survey Test Plans, the following changes to Subparagraph 7.4.1, “Selection of Spaces where Measurements are to be Conducted”, of each ambient environmental aspect of Comfort are to be followed:

- i) Measurements shall be taken in all areas affected by vessel alterations, if any. Measurements are limited to the ambient environmental aspect affected by the alteration. For example, structural changes require both whole-body vibration and noise measurements. Structural changes do not necessarily require indoor climate or lighting measurements. Changes to luminaires require lighting measurements but not whole-body vibration, noise or indoor climate measurements.
- ii) For all ambient environmental aspects, measurements shall be taken in all worst case or problem area locations based on the requirements set forth in 7.4.1, “Selection of Spaces where Measurements are to be Conducted”, of the appropriate Section of the Guide. [For example, worst case for whole body vibration is described in 2/7.4.1i)].
- iii) For all ambient environmental aspects, measurements shall be taken in twenty-five (25) percent of passenger cabins and staterooms identified in the initial Test Plans. The cabin locations must be representative of locations port, starboard, fore, amidships, and aft. Any worst case locations can be considered part of the representative sample for passenger cabins and staterooms, if applicable.
- iv) For all ambient environmental aspects, measurements shall be taken where a single instance of one (1) type of a manned space exists within the vessel (e.g., bridge, radio room, officer’s mess, gymnasium, library, etc.). The worst case locations can be considered part of the single instance representative sample, if applicable.
- v) Where multiple instances of the same type space exist, a representative sample of at least twenty-five (25) percent of each type shall be selected for measurement for all ambient environmental aspects. The worst case locations are to be considered part of the representative sample, if applicable.
- vi) For the **COMF+** notation, vibration measurement locations relating to motion sickness shall be selected in accordance with the applicable criteria in 2/7.4.1, “Selection of Spaces where Measurements are to be Conducted”.

For all ambient environmental conditions, visual/walk-through inspections are to be conducted in accordance with Subparagraph 7.4.2 of the appropriate section of the Guide.

3.5 Comfort on Yachts

For creation of the Special Periodical Survey Test Plans, Subsection 11, “Test Plan”, and Subsection 13, “Test Requirements”, of Sections 2 and 3 of the Guide specify the requirements for each ambient environmental aspect (i.e., 2/11, 2/13, etc.). For specifying measurement locations for the Special Periodical Survey Test Plans, the following are to be followed:

- i) Whole-body vibration measurements shall be taken in all Owner/guest spaces.
- ii) Noise measurements shall be taken in all Owner/guest spaces.

For both ambient environmental conditions, visual/walk-through inspections are to be conducted in accordance with Subparagraph 13.7.2 of the appropriate Section of the Guide.

5 Requirements for Vessel Alterations

No alterations which affect or may affect the Comfort notation awarded (**COMF**, **COMF+**, **COMF(Y)**, or **COMF+(Y)**), including alterations to the structure, machinery, electrical systems, piping, furnishings or lighting systems, are to be made to the vessel unless plans of the proposed alterations are submitted and approved by ABS before the work of alteration is commenced. If ABS determines that the alteration will affect the Comfort notation, the altered vessel may be subject to the review, verification and ambient environmental testing requirements of the Guide.

PART 7

CHAPTER 9 Survey Requirements for Additional Systems and Services

SECTION 18 Compliance with the ILO Maritime Labour Convention, 2006 Title 3 Requirements (1 July 2015)

1 Annual Surveys

The following information is to be reviewed by the attending ABS Surveyor for issues that could affect the Accommodation notation (**MLC-ACCOM**, **MLC-ACCOM(SPS)**, or **MLC-ACCOM(WB)**).

- i) Collision and grounding reports since the previous Initial, Annual, or Special Periodical Survey, if any
- ii) Fire, repair, and damage reports since the previous Initial, Annual, or Special Periodical Survey, if any
- iii) A list of all structural or mechanical modifications to the vessel since the previous Initial, Annual, or Special Periodical Survey, if any
- iv) Verification that equipment and facilities continue to be fit for purpose and are operating in accordance with the criteria stated within the *ABS Guide for Compliance with the ILO Maritime Labour Convention, 2006 Title 3 Requirements* (referred to as “the Guide” hereinafter)

During the attending ABS Surveyor’s review of the submitted information, a determination will be made as to whether changes or alterations have taken place that could affect the Accommodation notation. As a result, the vessel may be subject to the review, ambient environmental testing, and inspection requirements of the Guide.

3 Special Periodical Surveys

3.1 Survey Requirements

The Survey is to be comprised of ABS Engineering reviews, ABS Surveyor accommodation verifications and witnessing of ambient environmental testing. The Survey will cover all applicable accommodation aspects.

The following is to be submitted to ABS three (3) months prior to carrying out the ambient environmental testing:

- i) Fire, repair, or damage reports since the previous Annual Survey, if any
- ii) A list of all structural or mechanical modifications to the vessel since the previous Annual Survey, if any
- iii) Drawings/arrangements of seafarer spaces, HVAC, electrical, etc., affected by alterations, if any
- iv) Copies of the approved Initial Test Plans and Test Reports
- v) Copies of Test Plans and Test Reports resulting from Annual Surveys, if any
- vi) Previous Special Periodical Survey Test Plans and Reports
- vii) Proposed Special Periodical Survey Test Plans for the current survey

The Special Periodical Survey data submittal serves three purposes. The first is to perform an ABS Engineering review of seafarer spaces against any alterations to the vessel related to the criteria in Appendix 3 of the Guide since the Initial Survey, with measurements verified by an ABS Surveyor. The second purpose is to provide a history of ambient environmental testing, as well as the Special Periodical Survey ambient environmental Test Plans for review and approval by ABS Engineering. The third is to allow scheduling of measurement verifications and ambient environmental testing by an ABS Surveyor.

A Special Periodical Survey Test Plan for each ambient environmental aspect of accommodation areas is to be submitted in accordance with the criteria stated below. The approved initial Test Plans should be used as a basis for creating the Special Periodical Survey Test Plans.

For creation of the Special Periodical Survey Test Plans, Subsection 6, “Test Plan”, and Subsection 7, “Test Requirements”, of Sections 3 through 6 of the Guide specify the requirements for each ambient environmental aspect (i.e., 3/6, 3/7, 4/6, 4/7, etc.). For specifying measurement locations for the Special Periodical Survey Test Plans, the following changes to 7.4.1, “Selection of Spaces where Measurements are to be Conducted”, of each ambient environmental aspect are to be followed.

- i) Measurements are to be taken in all areas affected by vessel alterations, if any. Measurements are limited to the ambient environmental aspect affected by the alteration. For example, structural changes require both whole-body vibration and noise measurements. Structural changes do not necessarily require indoor climate or lighting measurements. Changes to luminaires require lighting measurements but not whole-body vibration, noise, or indoor climate measurements.
- ii) For all ambient environmental aspects, measurements are to be taken in all worst case or problem area locations based on the requirements set forth in 7.4.1, “Selection of Spaces where Measurements are to be Conducted”, of the appropriate Section of the Guide. [For example, worst case for whole-body vibration is described in 3/7.4.1i)].
- iii) For all ambient environmental aspects, measurements are to be taken in twenty-five (25) percent of crew cabins and staterooms identified in the initial Test Plans. The cabin locations must be representative of locations port, starboard, fore, amidships, and aft on each deck. Any worst case locations can be considered part of the representative sample for crew cabins and staterooms, if applicable.
- iv) For all ambient environmental aspects, measurements are to be taken where a single instance of one (1) type of a manned space exists within the vessel (e.g., officer’s mess, gymnasium, library, etc.). The worst case locations can be considered part of the single instance representative sample, if applicable.
- v) Where multiple instances of the same type space exist, a representative sample of at least twenty-five (25) percent of each type is to be selected for measurement for all ambient environmental aspects. The worst case locations are to be considered part of the representative sample, if applicable.

For all ambient environmental conditions, visual/walkthrough verification inspection locations are to be conducted in accordance with 7.4, “Measurement Locations” of the appropriate Section of the Guide.

5 Requirements for Vessel Alterations

No alterations which affect or may affect the Accommodation notation awarded (**MLC-ACCOM**, **MLC-ACCOM(SPS)**, or **MLC-ACCOM(WB)**), including alterations to the structure, machinery, electrical systems, piping, furnishings, or lighting systems, are to be made to the vessel unless plans of the proposed alterations are submitted to and approved by ABS before the work of alteration is commenced. If ABS determines that the alteration will affect the Accommodation notation, the altered vessel may be subject to the review, verification, and ambient environmental testing requirements of the Guide.

PART
7

CHAPTER 9 Survey Requirements for Additional Systems and Services

SECTION 19 Yachts (1 July 2015)

1 All Yachts

1.1 Annual Survey

At each Annual Survey, in addition to surveys of hull, machinery and equipment otherwise required by the Rules, the survey is also to include the following:

- Confirmation that the Operating Manual is maintained onboard (refer to 3-2-1/7 of the *ABS Guide for Building and Classing Yachts*.)

3 Commercial Yachting Service Notation

3.1 Annual Survey

At each Annual Survey, in addition to surveys of hull, machinery and equipment otherwise required by the Rules, the survey is also to include the following:

- Confirmation that vessels are in compliance with recognized statutory requirements for commercial yachts such as the UK MCA *The Large Commercial Yacht Code (LY3)*, as required by 1-1-3/1.1.3 of the *ABS Guide for Building and Classing Yachts*.
- Confirmation that the vessel has been provided with a Statutory Certification issued by the Flag Administration and that the subject certification is kept duly updated, including compliance with all periodical surveys, as set forth by the applicable Statutory Requirements.

5 Passenger Yachting Service Notation

5.1 Annual Survey

At each Annual Survey, in addition to surveys of hull, machinery and equipment otherwise required by the Rules, the survey is also to include the following:

- Confirmation that vessels are in compliance with recognized statutory requirements for passenger yachts such as the UK MCA “*REG 13-36 Passenger Yacht Code*”, as required by 1-1-3/1.1.5 of the *ABS Guide for Building and Classing Yachts*.
- Confirmation that the vessel has been provided with a Statutory Certification issued by the Flag Administration and that the subject certification is kept duly updated, including compliance with all periodical surveys, as set forth by the applicable Statutory Requirements.

PART
7

CHAPTER 9 Survey Requirements for Additional Systems and Services

SECTION 20 Tailshaft Condition Monitoring (2007)

1 TCM Notation (2006)

For vessels with **TCM** notation, the tailshaft survey interval required by 7-2-1/13.1.1 will be extended up to 15 years provided:

- i) Annual surveys are carried out to the satisfaction of the attending Surveyor, and
- ii) The following are carried out at each tailshaft survey due date required by 7-2-1/13.1.1.
 - Bearing wear-down measurement
 - Verification that the propeller is free of damage which may cause the propeller to be out of balance
 - Verification of effective inboard seal
 - Renewal of outboard seal in accordance with manufacturer's recommendation

1.1 Annual Survey

Satisfactory operating conditions of the tailshaft are to be confirmed, including the verification of the condition monitoring monthly records and analysis records of lubricating oil, as required by SVR 4-3-2/13.

1.3 Initial Survey for Existing Vessels obtaining TCM Notation

The following are to be carried out to the satisfaction of the attending Surveyor.

- i) All systems required by SVR 4-3-2/13 are to be examined and tested in accordance with the approved plans to verify compliance with SVR 4-3-2/13, and
- ii) Complete tailshaft survey will be required if the last complete tailshaft survey was carried out more than 5 years prior to the initial survey, or
- iii) Complete tailshaft survey may be waived subject to satisfactory review of the following records for appropriate period as considered necessary by ABS.
 - Stern bearing oil analysis records
 - Stern bearing oil consumption records
 - Stern bearing temperature monitoring records
 - Tailshaft, stern bearing assembly and propeller operation and repair records
 - Stern bearing clearance and wear-down measurement records

PART

7

CHAPTER 9 Survey Requirements for Additional Systems and Services

SECTION 21 Oil Carriers Equipped for Mooring at Single Point Moorings (*1 July 2011*)

1 SPMA Notation

For Oil Carriers with **SPMA** notation, the following are to be carried out to the satisfaction of the attending Surveyor.

1.1 **Annual Surveys**

Chain stoppers and fairleads, including foundations, are to be examined.

1.3 **Special Periodical Surveys**

Chain stoppers, fairleads, winches, capstans, and other deck fittings, including all foundations, are to be examined and operationally tested.

PART
7

CHAPTER 9 Survey Requirements for Additional Systems and Services

SECTION 22 Inert Gas Systems for Ballast Tanks (2014)

1 IGS – Ballast Notation

The equipment and arrangements required for the optional notation **IGS – Ballast** are to be examined, as follows:

1.1 Annual Surveys

In addition to the applicable requirements of 7-6-2/1.1.12, the Annual Survey is also to include the following:

1.1.1 Alarm and Safety Device

Verify the operation of the following alarms and safety devices, using simulated conditions where necessary:

1.1.1(a) Flue Gas System

- i) SO₂ content in excess of 2 ppm.
- ii) Manual emergency shutdowns of ballast pump prime movers located where the ballast system is normally controlled.
- iii) Accuracy of fixed and portable SO₂ measuring equipment by means of calibration gas.

1.1.1(b) Gas Generating Systems

- i) SO₂ content in excess of 2 ppm.
- ii) Manual emergency shutdowns of ballast pump prime movers located where the ballast system is normally controlled.
- iii) Accuracy of fixed and portable SO₂ measuring equipment by means of calibration gas.

1.1.1(c) Nitrogen Generating Systems. Manual emergency shutdowns of ballast pump prime movers located where the ballast system is normally controlled.

1.3 Special Periodical Surveys

The Special Periodical Survey is to be carried out in accordance with the applicable requirements as contained in 7-6-2/3.1.1(o).

PART
7

CHAPTER 9 Survey Requirements for Additional Systems and Services

SECTION 23 Inventory of Hazardous Materials (2017)

1 Introduction

The Inventory is to be subjected to annual surveys for maintenance of the **IHM** notation.

3 Annual Survey

The Inventory will be subjected to an annual survey in accordance with the *ABS Rules for Survey After Construction (Part 7)* in the course of completing other annual and periodical surveys.

See *ABS Guide for the Inventory of Hazardous Materials*, Section 2, Table 1C for the list of documents to be made available onboard for the annual survey of the Inventory.

The annual survey is to verify the following:

- The Inventory has been maintained and updated to reflect changes in vessel structure and equipment based on the records in the maintenance manual, to the satisfaction of the Surveyor.
- MD and SDOC have been collected for purchases of materials, machinery or equipment, coating renewal and spares from the date of the last Survey verification of the Inventory or Inventory supplements thereof. Deletion of equipment and/or parts of the ship's structure previously classed as PCHM from the Inventory complies with the requirements 2/3.5v) of the *ABS Guide for the Inventory of Hazardous Materials*.
- The Inventory, especially the location of hazardous materials, is consistent with the arrangements, structure and equipment of the vessel through an onboard visual inspection.

5 Additional Survey

When a ship undergoes a replacement or repair of the structure, equipment, systems, fittings, arrangements or material, which has a significant impact on the ship's Inventory, the shipowner is to request ABS for an additional survey of the Inventory.

See Section 2, Table 1D of the *ABS Guide for the Inventory of Hazardous Materials* for the list of documents to be made available onboard for the additional survey of Inventory.

The additional survey is to be carried out with an updated Inventory or an Inventory supplement that has been reviewed by Engineering without outstanding technical comments. The survey is to verify that the updated Inventory or additional supplements to the Inventory, especially the location of hazardous materials, is consistent with the arrangements, structure and equipment of the vessel through an onboard visual inspection.

PART
7

CHAPTER 10 Steel Floating Dry Docks

CONTENTS

SECTION 1	Survey Interval	238
1	Biennial Surveys	238
3	Special Periodical Surveys	238
5	Continuous Surveys	238
7	Drydocking Surveys or Equivalent Underwater Inspections	238
9	Machinery Surveys	238
SECTION 2	Hull Surveys	239
1	Biennial Surveys	239
3	Special Periodical Surveys	239
SECTION 3	Machinery Surveys	241

PART

7

CHAPTER 10 Steel Floating Dry Docks

SECTION 1 Survey Interval

1 Biennial Surveys

Biennial surveys are to be made once during each two years of service.

3 Special Periodical Surveys

For dry docks built under Classification Survey, the first Special Periodical Survey becomes due six years after the date of build or six years from the date of the Special Periodical Survey for Classification. Subsequent Special Periodical Surveys are due six years after the crediting date of the previous Special Periodical Survey. The interval between Special Periodical Surveys may be reduced by the Committee. If a Special Periodical Survey is not completed at one time, it will be credited as of the end of that period during which the greatest part of the survey has been carried out.

5 Continuous Surveys

At the request of the owner, and upon approval of the proposed arrangements, a system of Continuous Surveys may be undertaken whereby the Special Periodical Survey requirements may be carried out in regular rotation to complete all of the requirements of the particular Special Periodical Survey within a six-year period.

7 Drydocking Surveys or Equivalent Underwater Inspections

This survey is to be carried out at six-year intervals. Unless dry docked or careened to the Surveyor's satisfaction, the Owner's proposal for survey of that part of the dry dock below the light waterline is to be submitted for consideration. This proposal is to include such information on the dry dock as the type of coatings and form of corrosion control, if any. Consideration may be given to any special circumstances justifying an extension of the interval of survey. Where it is intended to careen the dry dock, consideration is to be given to the stability and longitudinal strength of the dry dock. Where applicable, such information is to be included in the operating manual.

9 Machinery Surveys

The intervals of Special Periodical Surveys are to be six years. A general examination of machinery, boilers, etc. is to be made at intervals of two years.

PART
7

CHAPTER 10 Steel Floating Dry Docks

SECTION 2 Hull Surveys

1 Biennial Surveys

At each Biennial Survey, the following parts are to be examined, placed in good condition and reported upon:

1.1

Pontoon decks, safety decks and top decks, wing wall plating above the light waterline, keel blocks and side blocks and their foundations.

1.3

Vents and overflow pipes, air pipes extending below decks to form air cushions, overboard scuppers, discharges and intakes, ventilator coamings and closing appliances required as a condition of classification and their coamings, where fitted.

1.5

Companionways, ladders, and guardrails and other means of protection that might be provided for access to all spaces.

1.7

All parts particularly liable to rapid deterioration.

1.9

Deflection control system.

1.11

The arrangement for fire protection, detection and extinction.

3 Special Periodical Surveys

Special Periodical Survey is to include compliance with all Biennial Survey requirements, and the Surveyor is to satisfy himself, by examination, that all means of protection to openings are in good condition and are readily accessible. Effect is also to be given to the following requirements:

3.1

Pontoon and wing wall tanks are to be cleaned, examined internally, and tested to the satisfaction of the Surveyor. At the discretion of the Surveyor, fuel oil tanks forming part of the main structure need not be examined internally until the dry dock is more than 12 years old.

3.3

Spaces above the safety deck are to be examined internally, removing linings, etc., where necessary for inspection. Air pipes extending below deck to form air cushions are also to be examined.

3.5

Where the surface of plating is covered with cement, composition, or wood sheathing, the covering is to be examined and sounded. If cement or composition is found to be not adhering to the plating, it is to be removed for examination of the plating. Where wood sheathing is deteriorated or badly worn, it is to be removed for examination of the plating.

3.7

The means of escape from machinery spaces, crew spaces and spaces in which crew are normally employed are to be examined.

3.9

Where fitted, sounding pipes are to be examined and the thick steel plate fitted below each sounding pipe for the rod to strike upon is to be securely fixed.

3.11

The Surveyor may require the thickness of any part of the structure where wastage is evident to be determined by an approved method. Where necessary, the structure is to be renewed by material of approved scantling and specification and the surfaces recoated.

3.13

Additionally, at the first Special Periodical Survey after the dry dock is 24 years old, and at 12 year intervals thereafter, the thicknesses of the structure are to be determined by an approved method to assess the general condition. Thickness measurements for two transverse sections are to be made within the midship $0.4L$ of the dry dock.

PART

7

CHAPTER 10 Steel Floating Dry Docks

SECTION 3 Machinery Surveys

Surveys of boilers, machinery, piping, valves, pumps and electrical equipment are to be in accordance with the requirements of Part 7, Chapter 6, as far as applicable.

PART
7

CHAPTER 11 Underwater Vehicles, Systems and Hyperbaric
Facilities

CONTENTS

SECTION 1	General	245
1	Technical Assistance	245
3	Maintenance and Log Books	245
5	Surveys of Manned or Unmanned Underwater Structures	245
SECTION 2	Survey Interval	246
1	Annual Surveys	246
3	Special Periodical Surveys	246
5	Year of Grace	246
SECTION 3	Annual Surveys	247
1	All Systems	247
1.1	Pressure Boundaries	247
1.2	Viewports	247
1.3	Life Support Systems	247
1.5	Ballasting, Flotation and Buoyancy Systems	247
1.7	Communications Systems	247
1.9	Electrical Systems	248
1.11	Emergency Arrangements	248
1.13	Propulsion	248
1.15	Corrosion Control Systems	248
1.17	Instrumentation	248
1.19	Special Items	248
1.21	Operational Dive	248
3	Dive Control Stations	248
3.1	Control Systems	248
3.3	Control Functions, Displays and Alarms	248
3.5	Fire Protection Systems	248
3.7	Electrical, Communications and Piping Systems	249
5	Chambers, Diver Training Centers and Dive Simulators	249
5.1	Functional Tests	249
5.3	Pressure Boundaries	249
5.5	Fire Extinguishers	249
5.7	Electrical Systems	249
5.9	Viewports	249

7	Handling Systems	249
7.1	General.....	249
7.3	Lubrication of Wire Rope	249
7.5	Ends Exchange	249
7.7	Testing.....	249
9	Remotely Operated Vehicles	250
11	Passenger Submersibles	250
SECTION 4 Special Periodical Surveys.....		252
1	All Systems	252
1.1	General.....	252
1.3	Valves in Pressure Boundaries	252
1.5	Ballasting and Deballasting Systems	252
1.7	Life Support Systems	252
1.8	Viewports.....	252
1.9	Gauges and Monitoring Instruments	253
1.10	Electrical Systems	253
1.11	Pressure Hull.....	253
1.12	Machinery.....	253
1.13	Test Dive	253
1.15	Diving Bells and Lock-Out Compartments.....	253
3	Dive Control Stations, Chambers, Diver Training Centers and Dive Simulators.....	253
3.1	Leak Test.....	253
3.3	Relief Valves	253
3.5	Electrical Resistance	253
3.7	Portable Pressure Containers	253
3.9	Fixed Pressure Containers	254
3.11	Instruments.....	254
5	Handling System.....	254
5.1	Testing.....	254
7	Remotely Operated Vehicles	254
7.1	External Hydrostatic Testing of Pressure Containers	254
7.3	Internal Hydrostatic Testing of Pressure Containers	254
7.5	Dimensional Checks.....	254
7.7	Hydrostatic Testing of Piping Systems	254
7.9	Instrumentation.....	254
7.11	Electrical Equipment.....	254
7.13	Functional Testing	254
7.15	Umbilicals and Fittings.....	254
SECTION 5 Surveys for Transit Damage.....		255
SECTION 6 Replacement of Viewports		256

SECTION 7	Relocation or Reinstallation of Portable Diving Systems	257
1	Lay-up and Reactivation	257
3	Surveys for Transit Damage	257
5	Integration Survey	257
5.1	Plan Review	257
5.3	Survey of Integration	257

PART

7

CHAPTER 11 Underwater Vehicles, Systems and Hyperbaric Facilities

SECTION 1 General

1 Technical Assistance

The Surveyor may require the attendance of technically qualified personnel during construction and post-construction surveys and repairs. Such attendance may be required for the following:

- Life support system and monitoring equipment.
- Hyperbaric systems, lock in, lock out facilities.
- Electronic equipment and communication systems.
- Emergency operation after system malfunction due to component failure, loss of power, loss of breathing gas pressure, flooding of the breathing circuits and others.

3 Maintenance and Log Books

All underwater vehicles and hyperbaric facilities together with their mechanical and auxiliary equipment are required to be maintained in good order and satisfactory operating conditions for which they were approved.

A log book is to be maintained by the person responsible for the mission. This log is to contain maximum dive depths, times, dates, duration and other details consistent with the mission of the unit.

A log is to contain certificates of maintenance based on inspections and checks by the crew and the inspection personnel. The inspection procedures and check lists are also to be part of the log book. The log books are to be signed by two responsible individuals and are to be presented to the Surveyor at each survey required by these Rules.

5 Surveys of Manned or Unmanned Underwater Structures

Permanently installed manned or unmanned underwater structures are to be subject to underwater inspection on an annual basis and to ultrasonic testing during a Special Periodical Survey. These underwater inspections and thickness measurements are to be conducted by an independent agency capable of such a service and the agency's certified results are to be submitted for review.

Procedures for the use of remotely operated vehicles for external inspection of the pressure boundary and external structures will be subject to special consideration.

PART

7

CHAPTER 11 Underwater Vehicles, Systems and Hyperbaric Facilities

SECTION 2 Survey Interval

1 Annual Surveys

Annual Surveys of the hull, machinery and equipment are to be made within three months either way of each annual anniversary date of the crediting of the previous Special Periodical Survey or original construction date.

3 Special Periodical Surveys (2017)

A Special Periodical Survey is to be completed within three years after the date of build or after the crediting date of the previous Special Periodical Survey, except as noted below. **Upon request from the Owner, the Certificate can be extended for up to three months by a Surveyor after a general examination of the vehicle, system, or facility.** Alternatively, a year of grace for completion of the Special Periodical Survey may be granted upon satisfactory completion of the Year of Grace Survey, as noted in 7-11-2/5. The interval between Special Periodical Surveys may be reduced by the Committee. If a Special Periodical Survey is not completed at one time, it will be credited as of the completion date of the survey but no later than Four years from date of build or from the date recorded for the previous Special Periodical Survey.

Where the Special Periodical Survey is commenced more than three months prior to the due date, the entire survey is normally to be completed within 15 months if such work is to be credited to the Special Periodical Survey.

5 Year of Grace (1 July 2008)

To be eligible for the year of grace to complete the Special Periodical Survey within one year after the due date, the unit is to be presented for survey up to a maximum of three months prior to the Special Periodical Survey due date. The requirements for surveys to qualify for a period of grace will be specially considered in each case.

If the survey is satisfactory, the completion of the Special Periodical Survey may be deferred for a period not exceeding twelve months from the due date, provided the whole Special Periodical Survey is satisfactorily completed within four years from date of build or from the date recorded for the previous Special Periodical Survey.

PART

7

CHAPTER 11 Underwater Vehicles, Systems and Hyperbaric Facilities

SECTION 3 Annual Surveys

1 All Systems

(1 July 2006) The Surveyor is to review the Operating and Maintenance Manuals, operational and maintenance records, log books including all recorded malfunctions or repairs carried out since the last Annual Survey and assure their proper maintenance and reporting. Summarized procedures for normal and emergency operations are to be verified on board the unit. The Annual Survey is to include surveys of the following, as applicable:

1.1 Pressure Boundaries *(1 July 2006)*

Internal and external surfaces of pressure boundaries, including all appendages, penetrations, hatches, hatch coamings, latching devices, lifting lugs, windows, plugs, hull stop valves, gaskets and support frames. External fairings are to be removed as far as practicable to provide good access to the entire surface of the pressure boundaries. Removal of protective coatings and insulation will not be required unless deterioration or trace of rust or corrosion is evident or as otherwise may be required by the Surveyor for inspection and non-destructive testing. Drydocking survey or equivalent underwater inspection of the vehicle below the light waterline is to be carried out to the Surveyor's satisfaction. Unless the vehicle is dry docked to the Surveyor's satisfaction, the Owner's proposal for the equivalent survey is to be submitted for consideration. This proposal is to include such information on the vehicle as the type of coatings and form of corrosion control, if any.

1.2 Viewports *(1 July 2006)*

All viewports are to be examined for possible deterioration (crack, crazing) or any other superficial damage. Inspection is to be in accordance with ASME-PVHO-2-2003. Viewports are not to be repaired without prior approval from an ABS Technical Office.

1.3 Life Support Systems *(1 July 2006)*

Life support system, including oxygen bottles, valves, gauges, fire protection, monitoring equipment, scrubber systems and emergency equipment. All life support items surveyed are to show continued compliance with the *ABS Rules for Building and Classing Underwater Vehicles, Systems and Hyperbaric Facilities* Section 8. Particular attention is to be given to oxygen or other gas bottles made of aluminum alloys due to risk of corrosion in way of the fastening connections. Fire detection equipment, where fitted, is to be examined and tested. Fixed fire fighting systems and portable fire extinguishers are to be serviced every 12 months.

1.5 Ballasting, Flotation and Buoyancy Systems *(1 July 2006)*

Ballasting, deballasting, flotation and buoyancy systems, if fitted including piping, valves, pressure gauges and level gauges. Trim and ballast tanks are to be examined externally. Buoyancy foam blocks, if fitted, are to be examined externally. The proper operation of the water detection system is to be verified.

1.7 Communications Systems *(1 July 2006)*

Operational check of communications systems. Radio communication or conventional telephone for a tethered unit is to be checked. Ultrasound underwater telephone may be checked by simulation or during the test dive.

1.9 Electrical Systems (1 July 2006)

Electrical systems, including generators and battery systems. Automatic and manual switch from the main to the emergency source of power is to be tested. All systems are to be energized, tested and proven free from grounds. Pressure resistant battery pods are to be internally examined. Dielectric liquids in pressure enclosures are to be checked for possible contamination by water. The pressure compensating systems are to be checked for tightness. Wiring and equipment in battery pods or battery boxes are to be checked together with the density and level of the electrolyte in the batteries. Fuses and breakers are to be randomly checked.

1.11 Emergency Arrangements (1 July 2006)

Emergency arrangements, including jettison systems and their freedom of operation. All emergency equipment and systems are to be fully tested including jettisoning of weights and electrical connections in tethered units. Locking systems for jettisoning equipment are to be carefully examined following testing. Releasing systems for battery pods or battery boxes need not be tested if they appear to be maintained in good condition. Condition of self-disconnecting electrical plugs is to be checked.

1.13 Propulsion (1 July 2006)

Means of propulsion and thrusters are to be tested with particular attention to bearings, seals, propellers, shafting, controls and machinery foundations. Hydraulic pumps and equipment are to be tested and the hydraulic fluid analyzed for possible water contamination. The steering system is to be examined, including tillers and controls, and operationally tested.

1.15 Corrosion Control Systems (1 July 2006)

Corrosion control systems, including sacrificial anodes and protective coatings. Where fitted, carbon steel bolts are to be examined at random for excessive corrosion.

1.17 Instrumentation (1 July 2006)

Accuracy and proper functioning of instrumentation. Calibration records are to be available on request. Permanent markings for emergency controls are to be checked.

1.19 Special Items (1 July 2006)

Special items which affect safety, such as manipulators, umbilical cords and lifting frames. Verify that the system for jettisoning of manipulator arms has not been bypassed and is still in working condition. Verify that there are no modifications, such as addition of scientific equipment or special tools, which would affect the buoyancy and safe operation.

1.21 Operational Dive

An operational dive is to be conducted annually and systems operationally tested. The dive need not be to rated depth nor with full occupancy. A report on the dive is then to be issued to the Surveyor. The Surveyor need not be present at the annual test dive unless the Surveyor so requires.

3 Dive Control Stations

In addition to 7-11-3/1, at each Annual Survey, the Dive Control Station is to be generally examined so far as can be seen and placed in satisfactory condition. The survey is also to include the following items, as applicable:

3.1 Control Systems

All control systems are to be tested for proper functions and operations.

3.3 Control Functions, Displays and Alarms

Visual examination of all control functions, displays and alarms.

3.5 Fire Protection Systems

Visual examination of fire protection and fire fighting systems.

3.7 Electrical, Communications and Piping Systems

Examination of all electrical, communications and piping systems.

5 Chambers, Diver Training Centers and Dive Simulators

In addition to 7-11-3/1, at each Annual Survey, the Chamber, Diver Training Center and Dive Simulator is to be generally examined so far as can be seen and placed in satisfactory condition. The survey is also to include the following items, as applicable:

5.1 Functional Tests

Chambers are to be subject to functional tests in the presence of the Surveyor. Satisfactory operation at the maximum allowable working pressure, using the normal breathing gas, is to be demonstrated for life support systems, locks, shut-off valves, communication and electrical systems.

5.3 Pressure Boundaries

Examination of internal and external surfaces of pressure boundaries, including all penetrations, hatches, hatch coamings, latching devices, lifting lugs, windows, plugs, gaskets and support frames. Removal of protective coatings to inspect welds will not be required unless deterioration is evident or as may be required by the Surveyor for inspection and nondestructive testing.

5.5 Fire Extinguishers

Fire extinguishers.

5.7 Electrical Systems

Examination of electrical systems, including penetrators.

5.9 Viewports

Viewport examination.

7 Handling Systems (2014)

7.1 General

In addition to 7-11-3/1, at each Annual Survey the Launch and Recovery System is to generally examined as so far can be seen and placed in satisfactory condition. Additionally, the following is to be reviewed or confirmed by the attending Surveyor.

7.3 Lubrication of Wire Rope

Records of lubrication applications are to be reviewed by the attending Surveyor. Records of lubrication are to be maintained as part of the Record of Certification onboard the facility.

7.5 Ends Exchange

The ends of rope are to be exchanged every twelve months. Records of such exchange are to be maintained as part of the Record of Certification onboard the facility.

7.7 Testing

Following each ends exchange, except the first exchange, a section is to be removed from the end of the rope for destructive testing. Testing is to be in accordance with the *Rules for Building and Classing Underwater Vehicles, System, and Hyperbaric Facilities*. Records of destructive testing are to be maintained as part of the Record of Certification onboard the facility and are to be made available to the attending Surveyor. Destructive testing of the sample need not be witnessed by the attending Surveyor and may be limited to the review of the onboard Records.

9 Remotely Operated Vehicles

In addition to 7-11-3/1, at each Annual Survey, each Remotely Operated Vehicle and its handling and control systems are to be generally examined so far as can be seen and placed in satisfactory condition.

11 Passenger Submersibles (2005)

In addition to 7-11-3/1, each Annual Survey is also to include the following items, as applicable.

11.1 (2007)

Log book records are to be examined and verified that the submersible has been operating in waters with a sea-bed depth not greater than 105 percent of the rated depth (unless a specific exemption has been previously obtained from the ABS Technical Office for operating in waters with a sea-bed depth greater than 105 percent of the rated depth) as described in the approved operating manual, under the supervision of dedicated surface support and only in areas investigated and reported by the dive site report. (See 11/49.3.1 of the *ABS Rules for Building and Classing Underwater Vehicles, Systems and Hyperbaric Facilities*.)

11.3 (2007)

Confirmation that the dive site report is provided to the pilot prior to the first dive at each new dive site.

11.5 (2007)

Confirmation that the pilot stand is protected from tampering by passengers as per the approved arrangement.

11.7 (2007)

Examination and testing of the fixed bilge system and bilge alarm, where fitted.

11.9

Examination of the shatterproof protective screen provided on all windows normally accessible to passengers or confirmation of precautions taken to prevent passengers from causing physical damage to the windows.

11.11 (2007)

Confirmation that the surface and underwater maneuvering systems as per the approved arrangement are in satisfactory operating condition.

11.13 (2007)

Examination of the following or as approved navigation and position indication equipment.

- Means for determining distance from the seabed
- Mechanical dial gauge or analog depth indicator
- Means to indicate heel and trim
- Two locating devices not of the same type (i.e. surface locating device such as a strobe light or VHF radio and subsurface locating device such as an acoustic pinger, sonar reflector or buoy)

11.15

In addition to the requirements of 7-11-3/1.3, emergency life support items surveyed are also to show continued compliance with 11/35.9 of the *ABS Rules for Building and Classing Underwater Vehicles, Systems and Hyperbaric Facilities*, if applicable.

11.17 (2007)

Verification that sufficient emergency thermal protection, as approved during the construction of the submersible, is carried onboard as required and in satisfactory condition.

11.19

For submersibles having reduced reserve life support capacity in accordance with 11/35.5 of the ABS *Rules for Building and Classing Underwater Vehicles, Systems and Hyperbaric Facilities*, the following items are also to be examined.

- Log book records are to be examined and verified that the submersible has been operating at one of a finite number of sites, each of which is described in the approved operations manual, and the site selected for each dive is recorded in a shore-based log prior to the dive, and that maximum bottom depth at the site is not exceeding the depth that can be safely reached by SCUBA divers or may be limited by a dive plan or by emergency procedures in the operations manual.
- Confirmation that the submersible's surface support vessel can be reached by shore-based divers within one hour
- Confirmation that two separate ballast systems and a jettisonable weight are in satisfactory operating condition, including manual blow arrangements by divers for tanks of one of the ballast systems as specified in a dive plan
- Confirmation that a dive plan is prepared and maintained for use in the event of an emergency, and that rescue drills are performed as scheduled

PART

7

CHAPTER 11 Underwater Vehicles, Systems and Hyperbaric Facilities

SECTION 4 Special Periodical Surveys

1 All Systems

The following items are to be surveyed, as applicable:

1.1 General

All items required under Annual Survey (see Section 7-11-3).

1.3 Valves in Pressure Boundaries (1 July 2006)

All valves in the pressure boundaries are to be examined internally and externally, tested and found or placed in satisfactory conditions. Equivalent alternative means of inspection will be specially considered. One hull penetration of each type is to be removed for examination of threads. In addition all plugs are to be removed for examination of threads.

1.5 Ballasting and Deballasting Systems (2017)

Ballasting and deballasting piping systems **internally exposed to seawater** are to be hydrostatically tested to 1.25 times maximum allowable working pressure (MAWP). **All other ballasting and deballasting piping systems are to be pressurized to the MAWP using the fluid normally used in service, and tested for leakage.** Ballast tanks are to be examined internally and tank sounding system to be checked. Holding down arrangements of external tanks (battery pods, trim and ballast tanks, etc.) are to be examined for possible corrosion. All jettisoning systems are to be overhauled, examined and tested. The flotation characteristics of buoyancy foam, if fitted, and fastening to the structure is to be checked or tested.

1.7 Life Support Systems (1 July 2014)

All life support piping systems, including gas storage containers, are to be pressurized to the maximum working pressure, using the fluid normally used in service, and tested for leakage.

Gas storage containers are to be hydrostatically pressure tested to 1.25 MAWP and visually inspected internally (with a borescope) and externally, at least once during each Special Periodical Survey period and documents of such tests are to be maintained and reviewed.

Alternatively, gas storage cylinders are to be hydrostatically pressure tested and visually inspected internally (with a borescope) and externally, at least once every 5 years by a qualified third party in accordance with the requirements of the code/standard of manufacture (such as the US Department of Transport (DOT) requirements).

Where gas storage containers are fastened to the vessel's structure, bolts are to be removed for examination including the condition of the pressure vessels in way of the bolts.

1.8 Viewports (1 July 2006)

In general, all viewports are to be removed and conditions of viewport seating on frame carefully examined. Inspection is to be in accordance with ASME-PVHO-2-2003. In the case of conical and spherical sector viewports where the seating surface can be inspected without removing the window, removal may be waived by the Surveyor.

1.9 Gauges and Monitoring Instruments (1 July 2006)

All gauges and monitoring instruments including depth gauges, oxygen analyzers, main manometers, main ammeters and voltmeters, etc., are to be calibrated within a period of six months prior to the Special Periodical Survey. Appropriate documentation is to be provided to the Surveyor indicating such calibration has been performed.

1.10 Electrical Systems (1 July 2006)

All electrical cables and piping are to be checked inside and outside the pressure hull for possible physical deterioration. Ground fault and/or stray current detection system is to be examined and confirmed that no unacceptable ground faults or stray currents exceeding allowable limits are detected.

1.11 Pressure Hull (1 July 2006)

Protective coating and thermal insulation are to be removed in selected locations and pressure hull examined or, alternatively, pressure hull is to be gauged. Highly stressed parts such as lifting lug welding on main pressure hull are to be checked at random by dye penetrant or magnetic particle methods together with connecting appendages to shell. A geometrical measurement for permitted deviations of the pressure hull may be required by the Surveyor (see the *ABS Rules for Building and Classing Underwater Vehicles, Systems, and Hyperbaric Facilities*, Section 5 for dimensional tolerances). The Surveyor should require that a record be kept onboard of any measurements taken and that reference points be marked for use at future surveys. In case of doubt the results are to be submitted to the ABS Technical Office, which reviewed and approved the plans, for evaluation and comparison with the original readings.

1.12 Machinery (1 July 2006)

Machinery surveys are to be carried out in accordance with the applicable requirements of Part 7, Chapter 6. Propeller shafts penetrating the pressure boundary are to be removed and seals, bearings and propellers examined and renewed as necessary.

1.13 Test Dive

As part of the Special Periodical Survey, a test dive is to be performed in the presence of the Surveyor. This test is to be in accordance with Subsection 3/5 of the *ABS Rules for Building and Classing Underwater Vehicles, Systems, and Hyperbaric Facilities*, except that full occupancy is not required.

1.15 Diving Bells and Lock-Out Compartments

For diving bells and diver lock-out compartments, a leak test is to be conducted at the maximum allowable working pressure, using the breathing mixture normally used in service.

3 Dive Control Stations, Chambers, Diver Training Centers and Dive Simulators

In addition to the 7-11-4/1, the Special Periodical Survey is to consist of the following:

3.1 Leak Test

Leak test (to MAWP) using the breathing mixture normally used in service.

3.3 Relief Valves

Proper operation of relief valves.

3.5 Electrical Resistance

Electrical resistance tests.

3.7 Portable Pressure Containers

Inspection of portable pressure containers.

3.9 Fixed Pressure Containers

Examination and testing (to 1.25 the MAWP) of fixed pressure containers.

3.11 Instruments

Calibration of all instruments.

5 Handling System

In addition to 7-11-4/1, the Special Periodical Survey is to consist of the following:

5.1 Testing

The System is to be tested with a load equal to 125 percent of the rated capacity together with removal of pins from sheaves and pulley blocks for examination. Where the boom head and heel blocks are fitted with ball or roller bearings, the removal of the pins may be dispensed with at the discretion of the Surveyor. If removable weights are not available, a spring or hydraulic balance may be used for testing. In the case of use of spring or hydraulic balance, the proof load is to be applied with the system swung as far as possible, first in one direction and then in the other. The Surveyor may at the Surveyor's discretion, require the proof load to be applied with the system at intermediate positions. The test should not be regarded as satisfactory unless the indicator remains constant for a period of at least five minutes.

7 Remotely Operated Vehicles

In addition to 7-11-4/1, the Special Periodical Survey is to consist of the following:

7.1 External Hydrostatic Testing of Pressure Containers

External hydrostatic test of any pressure container at 1.25 times the maximum external pressure.

7.3 Internal Hydrostatic Testing of Pressure Containers

Hydrostatic test at 1.5 times maximum allowable internal working pressure for components with internal pressure rating.

7.5 Dimensional Checks

Dimensional check prior to and after hydrostatic tests prescribed as above.

7.7 Hydrostatic Testing of Piping Systems

Hydrostatic tests of piping systems to 1.5 times systems internal working pressure.

7.9 Instrumentation

Instrumentation tests after calibration of instrumentation.

7.11 Electrical Equipment

Insulation test of all electrical equipment.

7.13 Functional Testing

System functional test at rated depth. Adequate static and dynamic stability and control of steering system are to be demonstrated during operational test dive.

7.15 Umbilicals and Fittings

Tests of umbilicals and fittings.

PART

7

CHAPTER 11 Underwater Vehicles, Systems and Hyperbaric Facilities

SECTION 5 Surveys for Transit Damage

During the transportation of the underwater unit/system or hyperbaric facility, precautions are to be taken to protect the pressure hull, external structures, acrylic windows, batteries, etc. from undue deterioration or damage.

A survey for transit damage is to be conducted by the Surveyor after the transportation of an underwater vehicle or hyperbaric facility from the manufacturer's or the assembler's plant to the location of operations.

This survey is to include but may not be limited to the following:

- Pressure boundary and its components are to be visually checked for damage.
- Systems and components are to be inspected, and recalibration of instruments may be required if deemed necessary by the Surveyor.
- External structures, fairings and skins are to be checked for damage.
- Further in-depth examination may be required by and at the discretion of the Surveyor.

Similarly, a survey for transit damage is to be conducted after the transportation of an underwater unit/system or hyperbaric facility from one location of operations to another.

If the survey is carried out by the Owner and damage is found which affects or may affect classification, ABS is to be advised of the details and provisions are to be made for examination by the Surveyor at first opportunity.

PART

7

CHAPTER 11 Underwater Vehicles, Systems and Hyperbaric
Facilities

SECTION 6 Replacement of Viewports

Acrylic viewports are to be replaced in accordance with Section 7 of the *ABS Rules for Building and Classing Underwater Vehicles, Systems and Hyperbaric Facilities* or at shorter intervals if deterioration occurs in service. Repairs to viewports will be subject to special consideration.

PART

7

CHAPTER 11 Underwater Vehicles, Systems and Hyperbaric Facilities

SECTION 7 Relocation or Reinstallation of Portable Diving Systems (2017)

1 Lay-up and Reactivation

Upon the owner's notification to ABS that a system has been laid-up, the status will be noted in the unit's survey status and in the *Record*. When a diving system is removed from service, the owners are to advise ABS in writing, and it will be noted as "Laid Up" in ABS records. Once the system is laid up, all surveys will be held in abeyance.

A Reactivation Survey is to be carried out on diving systems when they are placed back in service in accordance with specific instructions issued by the Office of ABS Divisional Assistant Chief Surveyor – Offshore. The extent of the Reactivation Survey is generally dependent on the length of time in lay-up, the lay-up procedures followed, and the maintenance conditions during lay-up. The Reactivation Survey shall consist of at least the equivalent of an Annual Survey, completing any due and overdue surveys, and compliance with any outstanding recommendations.

3 Surveys for Transit Damage

A survey for transit damage is to be conducted by the Surveyor in accordance with Section 7-11-5 of these Rules after reinstallation of the diving system.

5 Integration Survey

An integration survey is to be conducted each time the diving system is installed on a new host vessel.

5.1 Plan Review

Plans are to be submitted for ABS Engineering review in accordance with the provisions of Subsection 14/17 of the *ABS Rules for Building and Classing Underwater Vehicles, Systems and Hyperbaric Facilities (Underwater Vehicles Rules)*.

5.3 Survey of Integration

The following items are to be examined in accordance with Subsection 14/17 of the *Underwater Vehicles Rules* for all work related to the integration survey.

- i) Structure and welding related to installation of the diving system is to be verified in accordance with Sections 4 and 5 of the *Underwater Vehicles Rules* and the *ABS Rules for Materials and Welding (Part 2)* when applicable.
- ii) An NDT plan for structure and piping welding is to be submitted to the attending Surveyor for review and acceptance, and is to conform to Section 9/7 of the *Underwater Vehicles Rules* and the *ABS Rules for Materials and Welding (Part 2)* as applicable. NDT is to be carried out in accordance with *ABS Guide for Nondestructive Inspection of Hull Welds*.
- iii) Modified or newly installed piping systems are to be subjected to pressure testing in accordance with Section 14 of the *Underwater Vehicles Rules*.

- iv) External piping, electrical cabling, and equipment are to be located to minimize the likelihood of damage during handling operations, or they are to be suitably protected.
- v) Electrical cabling and installation is to be in accordance with Section 14 of the *Underwater Vehicles Rules*, and subjected to an insulation resistance test at completion.
- vi) Public address, general alarm, and fire and gas detection systems are to be tested and proven satisfactory in accordance with Section 14 of the *Underwater Vehicles Rules* and Part 4 of the *Steel Vessel Rules* as applicable.
- vii) All machinery and associated equipment including emergency shut downs and stopping devices are to be examined and tested in presence of the attending Surveyor.
- viii) Upon completion of the above, a survey equivalent to Annual Survey of the diving system as per Section 7-11-3 of these Rules is to be carried out.

PART
7

CHAPTER 12 Sailing Yachts not Receiving AMS Notation
(1 July 2015)

CONTENTS

SECTION 1	Survey Intervals	260
1	Intermediate Classification Surveys.....	260
3	Special Periodical Surveys	260
5	Continuous Surveys.....	260
7	Machinery Surveys	260
SECTION 2	Hull Surveys	261
1	Intermediate Surveys	261
3	Special Periodical Surveys – Hull	262
3.1	Special Periodical Survey No. 1 and Subsequent Special Periodical Surveys	262
3.3	Special Periodical Survey No. 2 and Subsequent Special Periodical Surveys.....	263
3.5	Minimum Requirements for Thickness Measurement	264
SECTION 3	Machinery Surveys	265
SECTION 4	Comfort on Yachts	266

PART

7

CHAPTER 12 Sailing Yachts not Receiving AMS Notation

SECTION 1 Survey Intervals

1 Intermediate Classification Surveys (2005)

Intermediate Class Surveys – Hull are to be made between the second and third anniversary date of the crediting of the previous Special Periodical Survey – Hull or original construction date.

3 Special Periodical Surveys (2005)

Special Periodical Surveys – Hull are to be completed five (5) years after the date of build or after the crediting date of the previous Special Periodical Survey, except as noted below. The interval between Special Periodical Surveys may be reduced by the Committee. If a Special Periodical Survey is not completed at one time, it will be credited as of the completion date of the survey, but no later than five (5) years from date of build or from the date recorded for the previous Special Periodical Survey. If the Special Periodical Survey is completed prematurely but within three months prior to the due date, the Special Periodical Survey will be credited to agree with the effective due date. Special consideration may be given to Special Periodical Survey requirements in the case of yachts of unusual design, in lay-up or in unusual circumstances. The Committee reserves the right to authorize extensions of Rule-required Special Periodical Surveys under extreme circumstances.

5 Continuous Surveys (2005)

At the request of the Owner, and upon approval of the proposed arrangements, a system of Continuous Surveys may be undertaken whereby the Special Periodical Survey requirements are carried out in regular rotation to complete all of the requirements of the particular Special Periodical Survey within a five (5) year period. If the Continuous Survey is completed beyond the five (5) year period, the completion date will be recorded to agree with the original due date of the cycle. Each part (item) surveyed becomes due again for survey approximately five (5) years from the date of its survey. For Continuous Surveys, a suitable notation will be entered in the *Record* and the date of completion of the cycle published. If any defects are found during the survey, they are to be dealt with to the satisfaction of the Surveyor.

7 Machinery Surveys (2005)

The intervals of Special Periodical Surveys are to be five (5) years. A general examination of machinery, etc., is to be made between the second and third anniversary date of the crediting of the previous Special Periodical Survey or original construction date.

PART

7

CHAPTER 12 Sailing Yachts not Receiving AMS Notation

SECTION 2 Hull Surveys

1 Intermediate Surveys (1 July 2011)

(2005) At each Intermediate Survey, the following items are to be examined and placed in satisfactory condition:

1.1

The yacht is to be placed in drydock or on a slipway and the keel, stem, stern frame, rudder and outside of side and bottom are to be cleaned as necessary, examined and placed in satisfactory condition, together with rudder pintles, gudgeons and their securing arrangements. For those yachts constructed of aluminum, underwater plating in close proximity to dissimilar metal is to be examined both internally and externally as far as practicable. Rudder bearing clearances are to be ascertained and reported upon.

1.3

The yacht is to be generally examined externally and internally so far as can be seen and placed in satisfactory condition.

1.5

All openings to the sea, including sanitary and other overboard discharges, together with the valves connected therewith, are to be examined internally and externally while the vessel is in drydock; and the fastenings to the shell plating are to be renewed when considered necessary by the Surveyor. For those vessels constructed of aluminum, insulating material in joints of shell connections between dissimilar metals is to be examined and renewed, if necessary.

1.7

The following items are to be examined, together with their closing appliances, placed in satisfactory condition and reported upon:

- Superstructures
- Hatches
- Companionways
- Ventilator and air pipe coamings
- Skylights
- Flush deck scuttles
- All openings in yacht sides, including freeing ports

1.9

All accessible parts of the steering gear, including associated equipment and control systems, are to be examined and placed in satisfactory condition. Steering gear is to be operationally tested while the yacht is not under way.

1.11

Anchoring equipment is to be examined and placed in satisfactory condition.

3 Special Periodical Surveys – Hull

3.1 **Special Periodical Survey No. 1 and Subsequent Special Periodical Surveys** (1 July 2011)

(2005) Special Periodical Survey No. 1 is to include compliance with all Intermediate Survey requirements, and the Surveyors are to satisfy themselves, by examination in position, that all means of protection to openings are in good condition and are readily accessible. Effect also is to be given to the following requirements:

3.1.1

The yacht is to be placed in drydock or on a slipway and all applicable items of 7-12-2/1 examined.

3.1.2

Yachts of steel or aluminum are to be gauged in accordance with 7-12-2/3.5.

3.1.3

The rudder is to be examined, the condition of the carrier and steadiment bearing and the effectiveness of the stuffing boxes are to be ascertained.

3.1.4

All decks, casings and superstructures are to be examined. Particular attention is to be paid to the corners of openings and other discontinuities in way of decks and topsides.

3.1.5

The interior of the yacht is to be opened out by the removal of lining, ceiling, portable tanks and ballast, as may be required by the Surveyor to satisfy himself as to the condition of all parts of the structure. Integral tanks and other spaces, including chain lockers, are to be cleaned for examination. When examining tanks internally, the Surveyor is to see that a striking plate or other additional reinforcement is fitted below each sounding pipe.

3.1.6

All integral tanks are to be tested with a head of liquid to the highest point that liquid will rise under service conditions.

3.1.7

Anchor windlass and hawse pipes are to be examined. Anchors and cables are to be ranged and examined.

3.1.8

Exposed hatch covers not fitted with tarpaulins are to be hose-tested or otherwise proven weathertight.

3.1.9

All fastenings, including those through the ballast keel, are to be hammer-tested to ascertain their soundness and drawn for examination, as considered necessary by the attending Surveyor.

3.1.10

Wood decks or sheathing are to be examined and the caulking is to be tested and re-caulked, as necessary. If decay or rot is found or the wood is excessively worn, the wood is to be renewed. Attention is to be given to the condition of the structure under wood decks and to fabric deck coverings. If it is found that such coverings are damaged or are not adhering closely to the deck, sections are to be removed, as necessary, to ascertain the condition of the deck under.

3.1.11

In any part of the yacht where wastage is evident or suspect, the Surveyor may require thickness gauging and repair of the affected parts. See 7-12-2/3.5.

3.1.12

In addition, the following requirements apply to those yachts constructed of reinforced plastic:

3.1.12(a) The framing and holds, hull laminate of the tween deck, deep tanks, peaks, bilges and drain wells, and machinery spaces are to be cleaned and examined. Linings, ceiling, tanks and portable ballast are to be removed, as considered necessary by the attending Surveyor.

3.1.12(b) Where there is evidence of cracking, distortion, wetness or delamination, destructive or nondestructive testing and removal and repair of the defect are to be carried out to the satisfaction of the attending Surveyor.

3.1.12(c) Engine foundations and their attachment to the hull are to be examined.

3.1.12(d) The hull, fastenings and backing reinforcements in way of hull fittings and attachments are to be examined. Fastenings are to be withdrawn, as considered necessary by the attending Surveyor.

3.1.13

In addition, the following requirements apply to those yachts constructed of wood:

3.1.13(a) Where the planking is sheathed with metal, such portions are to be removed, as the Surveyor may direct. If sheathed with reinforced plastics or similar material, the sheathing is to be examined to ensure it is adhering satisfactorily and that there is no possibility of water seepage occurring along plank edges.

3.1.13(b) The caulking of the outside and deck planking is to be tested and re-caulked as necessary.

3.3 Special Periodical Survey No. 2 and Subsequent Special Periodical Surveys

Special Periodical Survey No. 2 is to include compliance with all requirements for Special Periodical Survey No. 1 and the following:

3.3.1

Plating in way of portlights is to be examined. In this and any other part of the structure where wastage is evident or suspect, the Surveyor may require thickness gauging in order to obtain the actual thickness of material.

3.3.2

The anchor cables are to be ranged and examined, together with anchors, chain locker and holdfasts. Chain cables are to be renewed in cases where it is found that the links have been so far worn that their mean diameter is 12% below the original required nominal size.

3.3.3

On all yachts fitted with a ballast keel, fastenings are to be drawn for examination, as may be required by the Surveyor.

3.3.4

If a wood yacht is sheathed with metal, such sheathing as will at least permit an examination of the wood keel, garboards, plank ends, stem and stern post is to be removed, as requested by the Surveyor.

3.3.5

In wood yachts, fastenings, as may be required by the Surveyor, are to be drawn for examination.

3.5 Minimum Requirements for Thickness Measurement

3.5.1 Special Periodical Survey No. 1 and 2

- Areas considered suspect by the Surveyor throughout the vessel.

3.5.2 Special Periodical Survey No. 3

- Two (2) transverse sections of shell and deck within the midship half-length, as deemed necessary by the Surveyor.
- Areas considered suspect by the Surveyor throughout the vessel.

3.5.3 Special Periodical Survey No. 4 and Subsequent Special Periodical Surveys

- Three (3) transverse sections of shell and deck within the midship half-length.
- Two (2) wind-and-water strakes, port and starboard, for the midship half-length.
- All exposed main deck and superstructure deck plating.
- Flat keel plating full length, plus extensive bottom plating.
- Areas considered suspect by the Surveyor throughout the vessel.

PART

7

CHAPTER 12 Sailing Yachts not Receiving AMS Notation

SECTION 3 Machinery Surveys *(2004)*

Machinery surveys are to be carried out in accordance with the applicable requirements of Part 7, Chapter 6.

PART

7

CHAPTER 12 Sailing Yachts not Receiving AMS Notation

SECTION 4 Comfort on Yachts (*1 July 2015*)

See Section 7-9-17 for the survey requirements.

PART
7

APPENDIX

CONTENTS

SECTION 1	Underwater Inspections in Lieu of Drydocking Surveys	279
1	Introduction	279
1.1	Scope and Application.....	279
1.3	Approval Procedure for UWILD Class Notation.....	279
1.5	Governmental Regulations	279
3	Conditions and Procedures.....	280
3.1	General.....	280
3.3	Conditions	281
3.5	Physical Features.....	282
3.7	Procedures	283
3.9	Alternatives.....	283
3.11	Maintenance of UWILD Class Notation	283
	FIGURE 1 Approval Procedures for UWILD Class Notation	280
SECTION 2	Surveys of Voyage Repairs to Hull Structure	284
1	General	284
3	Requirements.....	284
3.1	Requirements Prior to Commencement of Repairs	284
3.3	Repairs.....	285
3.5	Acceptance of Repairs	285
SECTION 3	Vessel Lay-up and Reactivation	286
1	Vessel Lay-up	286
1.1	Lay-up Surveys	286
1.3	Lay-up Site and Mooring Arrangements.....	287
1.5	Safety and Protection	288
1.7	Preservation and Maintenance.....	291
3	Reactivation of Laid-up Ships	295
3.1	Reactivation Survey Status	295
3.3	Reactivation – Hull and Outfit.....	295
3.5	Reactivation – Machinery	296
3.7	Electrical.....	297
3.9	Control and Instrumentation	297
3.11	Trials	297
3.13	Documentation and Certification	297
3.15	Additional Items for Consideration.....	297

SECTION 4	Additional Information for Hull Thickness Measurement	298
1	Purpose.....	298
3	The Thickness Measurement Process	298
5	Thickness Measurement Review	298
7	Thickness Measurement Reports	299
9	Thickness Measurement Company Approval Requirements	299
11	Thickness Measurement Requirements and Locations.....	300
13	Thickness Measurements of Structural Members Subject to Close-up Survey	300
15	Modification of Thickness Measurement Requirements.....	300
17	Additional Thickness Measurements and Substantial Corrosion ...	301
19	Suspect Areas.....	302
21	Thickness Measurements on Behalf of Underwriters	302
23	Thickness Measurements Carried Out Afloat	302
25	Installation and Inspection of Special Fixed Ballast Materials	303
25.1	General.....	303
25.3	Fixed Liquid Ballast.....	305
25.5	Fixed Ballast Using Solid Materials.....	305
25.7	Fixed Ballast Using Concrete	307
27	Individual Plate Wastage Allowances	307
29	Wastage Compensation and Repair.....	308
31	Wastage Rates – Effects on Thinner Members and Welds	309
33	Criteria for Longitudinal Strength of Hull Girder for Oil Tankers	309
33.1	General.....	309
33.3	Evaluation of Longitudinal Strength	309
35	Thickness Measurements Carried Out on IACS Common Structural Rules (CSR) Vessels.....	313
35.1	Bulk Carriers (Single Skin and Double Skin)	313
35.3	Double Hull Oil Tankers.....	315
TABLE 1	Individual Wastage Allowances, Conventional Vessels 90 M and Over Built to ABS Class	321
TABLE 2	Individual Wastage Allowances, Conventional Vessels Under 90 Meters (295 Feet).....	323
TABLE 3	Aluminum Wastage Allowances, Conventional Vessels Under 90 M (295 Feet) built to ABS Class.....	324
TABLE 4	Wastage Allowances, Steel or Aluminum Yachts 24 m (79 ft) – 61 m (200 ft) in Length	324
FIGURE 1	Typical Bottom Shell Thickness Measurement Patterns including Increased Pattern of Measurement in way of Substantial Corrosion.....	317
FIGURE 2	Example of Gauging Assessment – Individual Plate with Substantial Corrosion.....	318
FIGURE 3	Example of Edge Corrosion	319
FIGURE 4	Example of Grooving Corrosion.....	319
FIGURE 5	Pitting Intensity Diagrams	320

SECTION 5	Procedures for Certification of Firms Engaged in Thickness Measurement of Hull Structures	325
1	Application	325
3	Procedures for Certification	325
3.1	Submission of Documents.....	325
3.3	Auditing of the Firms	325
3.5	Onboard Demonstration	325
5	Certification	326
7	Alteration to the Certified Thickness Measurement Operating System	326
9	Cancellation of Approval.....	326
SECTION 6	Report on Thickness Measurement of Bulk Carriers – Non Double Skin (CSR and Non-CSR Vessels) and General Dry Cargo Vessels	327
1	Instructions.....	327
1.1	Non-CSR Vessels	327
1.3	CSR Vessels	327
1.5	Reporting Forms.....	328
TABLE 1	Interpretations of Rule Requirements for the Locations and Number of Points to be Measured for CSR Bulk Carriers (Single Skin).....	374
FIGURE 1	Thickness Measurement – Bulk Carriers: Typical transverse section indicating longitudinal and transverse members	363
FIGURE 2	Thickness Measurement – Bulk Carriers: Transverse section outline	364
FIGURE 3	Close-up Survey and Thickness Measurement Areas.....	365
FIGURE 4	Areas for Close-Up Survey of General Dry Cargo Ships.....	366
FIGURE 5	Transverse Section of Single Skin Bulk Carrier.....	368
FIGURE 6	Locations of Measurements on Hatch Covers and Coamings.....	369
FIGURE 7	Locations of Measurements on Structural Members in Cargo Holds and Ballast Tanks of Single Side Skin Bulk Carriers	370
FIGURE 8	Locations of Measurements on Cargo Hold Transverse Bulkheads	371
FIGURE 9	Locations of Measurements on Transverse Bulkheads of Topside, Hopper and Double Bottom Tanks.....	372
FIGURE 10	Locations of Measurements on Underdeck Structure.....	373
SECTION 7	Report on Thickness Measurement of Oil Carriers – Non Double Hull, Ore/Oil Ships – Non Double Hull and Chemical Carriers, etc.	376
1	Instructions.....	376

FIGURE 1	Thickness Measurement – Oil Carriers, Ore/Oil Ships, etc.: Oil Carrier – Typical transverse section indicating longitudinal and transverse members	392
FIGURE 2	Thickness Measurement – Oil Carriers, Ore/Oil Ships, etc.: Ore/Oil Ship – Typical transverse section indicating longitudinal and transverse members	393
FIGURE 3	Thickness Measurement – Oil Carriers, Ore/Oil Ships, etc.: Transverse section outline to be used for longitudinal and transverse members where typical Oil Carrier or Oil/Ore ship sections are not applicable	394
FIGURE 4	Thickness Measurement – Oil Carriers, Ore/Oil Ships, etc.: Typical transverse sections showing all longitudinal members to be reported on TM2-T and TM3-T	395
FIGURE 5	Thickness Measurement – Oil Carriers, Ore/Oil Ships, etc.: Close-up Survey Requirements	396
FIGURE 6	Thickness Measurement – Chemical Carriers	397
FIGURE 7	Thickness Measurement – Chemical Carriers	398
FIGURE 8	Thickness Measurement – Chemical Carriers	399
FIGURE 9	Thickness Measurement – Chemical Carriers	400
FIGURE 10	Representative Transverse Section of Chemical Tanker Areas A & B and 1 & 2	401
FIGURE 11	Representative Transverse Section of Chemical Tanker Areas C & D and 3, 4 and 5	402
FIGURE 12	Representative Transverse Section of Chemical Tanker Areas 6 and 7	403

**SECTION 8 Intermediate and Special Periodical Survey Preparation for
ESP and ESDC Vessels..... 404**

1	Sample Survey Plan for Intermediate and Special Periodical Surveys for ESDC Vessels	404
3	Guidelines for Technical Assessment in Conjunction with Planning for Enhanced Surveys	410
3.1	Introduction	410
3.3	Purpose and Principles	410
3.5	Technical Assessment	411
3.7	References	412
5	Owners Inspection Report	417
7	ESP Survey Program – Double Skin Bulk Carriers	418
9	ESP Survey Planning Questionnaire – Double Skin Bulk Carriers	423
11	ESP Survey Program – Non Double Skin Bulk Carriers.....	427
13	ESP Survey Planning Questionnaire – Non Double Skin Bulk Carriers	432
15	ESP Survey Program – Double Hull Oil Tankers and Chemical Carriers	436
17	ESP Survey Planning Questionnaire – Double Hull Oil Tankers and Chemical Carriers	440
19	ESP Survey Program – Non Double Hull Oil Tankers and Chemical Carriers	443
21	ESP Survey Planning Questionnaire – Non Double Hull Oil Tankers and Chemical Carriers	447

FIGURE 1	Technical Assessment and the Survey Planning Process	413
FIGURE 2	Typical Locations Susceptible to Structural Damage or Corrosion.....	414
FIGURE 3	Typical Damage and Repair Example (Reproduced From IACS, "Bulk Carriers: Guidelines for Survey, Assessment and Repair")	415
FIGURE 4	Typical Damage and Repair Example (Reproduced From TSCF "Guidance Manual for the Inspection and Condition Assessment of Tanker Structures")	416
SECTION 9	Reporting Principles for ESP Vessels	450
1	General	450
3	Extent of the Survey.....	450
5	Result of the Survey.....	451
7	Actions Taken with Respect to Findings.....	451
REPORT 1	Condition Evaluation Report for Bulk Carriers	452
REPORT 2	Condition Evaluation Report for Oil Carriers and Chemical Carriers	457
SECTION 10	Bronze and Stainless Steel Propeller Castings	462
1	Bronze Propellers	462
1.1	Introduction.....	462
1.2	Foundry Approval	462
1.3	Materials.....	462
1.5	Inspection	465
1.7	Welding	469
1.9	Straightening	472
1.11	Repitching	473
3	Stainless Steel Propellers.....	477
3.1	Introduction.....	477
3.2	Foundry Approval	477
3.3	Materials.....	477
3.5	Inspection	479
3.7	Welding	480
3.9	Straightening	483
3.11	Repitching	483
TABLE 1	Acceptance Criteria for Surface Inspection of Bronze and Stainless Steel Propellers	474
TABLE 2	Parameters for Welding of Type 2, Mn Bronze.....	475
TABLE 3	Parameters for Welding of Type 3, NiMn Bronze	475
TABLE 4	Parameters for Welding of Type 4, NiAl Bronze	475
TABLE 5	Parameters for Welding of Type 5, MnNiAl Bronze	476
TABLE 6	Temperatures for Straightening and Repitching Bronze Propellers	476

TABLE 7	Parameters for Welding of Grades CF-3 and CF-8 Stainless Steel	484
TABLE 8	Parameters for Welding of Grade CA-6NM Stainless Steel	485
TABLE 9	Parameters for Welding of Grade CA-15 Stainless Steel	485
TABLE 10	Parameters for Welding of Grade CB-6 Stainless Steel	485
TABLE 11	Temperatures for Straightening and Repitching Stainless Steel Propellers	486
FIGURE 1	Definition of Skew Angle	466
FIGURE 2	Severity Zones for Integrally-cast, Low Skew Propellers	467
FIGURE 3	Severity Zones in Blades with Skew Angles Greater than 25°	468
FIGURE 4	Severity Zones for Controllable Pitch Propeller Boss	468
FIGURE 5	Severity Zones for Controllable Pitch and Built-up Propeller Blades	469
FIGURE 6	Typical Shallow Groove Preparation for Welding Repair	486
FIGURE 7	Typical Deep Groove Preparation for Welding Repair	486
FIGURE 8	Typical Blade Tip Replacement Preparation for Welding Repair	487
FIGURE 9	Welding Qualification Test Plate Location of Test Specimens	487
FIGURE 10	Reduced-section Tension Specimen	488

SECTION 11	Repair and Cladding of Shafts	489
1	Scope	489
1.1	General	489
1.3	Materials	489
1.5	Arrangements, Fees, and Renewal of Approvals for Welding and Cladding	489
3	Repair without Welding	489
5	Repair by Welding – Facility Approval	489
5.1	General	489
5.3	Application for Approval	489
5.5	Welding Procedure	490
5.7	Ultrasonic Examination Procedure	490
5.9	Mechanical Tests	490
7	Preparation and Examination of Shafts Prior to Welding	491
9	Production Welding	491
9.1	Submission of Details	491
9.3	Welding Processes	491
9.5	Examination During Welding	491
9.7	Preheat and Interpass Temperature	492
9.9	Distortion Control	492
9.11	Postweld Heat Treatment	492
11	Examination after Welding	492
13	Final Finishing	492

15	Marking of Shafts Repaired by Welding	493
17	Cladding of Shafts by Welding.....	493
17.1	General.....	493
17.3	Facility Approval	493
17.5	Materials.....	493
17.7	Welder or Welder Operator Qualifications	493
17.9	Weld Procedure Approval.....	493
17.11	Cladding/Base Metal Dilution	494
17.12	Cladding on Taper	494
17.13	Finish Machining	494
17.15	Final Examination	494
17.17	Marking of Shafts Clad by Welding	494
19	Repair of Clad Shafts.....	494
19.1	General.....	494
19.3	Depth of Defect	494
19.5	Repair of Defects That Do Not Penetrate Into Base Metal	495
19.7	Repair of Defects That Penetrate Into Base Metal	495
19.9	Cladding Identification Procedures.....	495
21	Metal Spraying on Shafts and Liners.....	495
	Annex Suggested Form for Ultrasonic Inspection of Shafts	501
FIGURE 1	Joint Design for Weld Repair in Solid Shafting for Procedure Approval	496
FIGURE 2	Joint Design for Welding Hollow Steel Shafting for Procedure Approval	496
FIGURE 3A	Test Pieces and Requirements for Procedure Approval	497
FIGURE 3B	Location for Hardness Measurements Across the Weldment.....	498
FIGURE 4	Ultrasonic Test Shaft.....	498
FIGURE 5	Recommended Contour for Shafting at Liner	499
FIGURE 6	Suggested Hoop Stress Relief for Propeller Hub and Shaft Liner.....	499
FIGURE 7	Weld Procedure Test Specimens for Shafts with Built-up Welded Stainless Steel or Carbon Steel Cladding	500
FIGURE 8	Welder Qualification Test Cladding.....	500
SECTION 12	Ultrasonic Examination of Carbon Steel Forgings for Tail Shafts	505
1	Scope	505
3	Applicable Documents	505
5	Documentation.....	505
7	Apparatus and Technique.....	505
9	Personnel Requirements	506
11	Preparation of Forging for Ultrasonic Examination	506

13	Procedure.....	506
13.1	Coverage.....	506
13.3	Radial Scanning.....	506
13.5	Longitudinal Scanning Through Shaft Axis.....	507
15	Recording.....	507
15.1	Recordable Indication.....	507
15.3	Definitions.....	507
17	Reports.....	508
17.1	Report Content.....	508
17.3	Reporting of Indications Beyond Acceptance Levels.....	508
Annex Pertinent Sections of ASTM A388 Referenced in the Appendix.....		512
TABLE 1	Acceptance Quality Levels (Radial Scanning) for Tail Shaft Forgings.....	508
FIGURE 1	Extent of Ultrasonic Examination.....	509
FIGURE 2	Coverage for Sections 2 and 5 of 7-A-12/Figure 1.....	510
FIGURE 3	Coverage for Sections 1, 3, 4, and 6 of 7-A-12/Figure 1.....	510
FIGURE 4	Typical Discontinuities.....	511

SECTION 13 Report on Thickness Measurement of Oil Carriers – Double Hull (CSR and Non-CSR Vessels)..... 515

1	Instructions.....	515
1.1	Non-CSR Vessels.....	515
1.3	CSR Vessels.....	515
1.5	Reporting Forms.....	515
TABLE 1	Interpretations of Rule Requirements for the Locations and Number of Points to be Measured for CSR Double Hull Oil Carriers.....	551
FIGURE 1	Thickness Measurement – Oil Carriers – Double Hull: Typical transverse section of a double hull oil carrier up to 150,000 dwt indicating longitudinal and transverse members.....	545
FIGURE 2	Thickness Measurement – Oil Carriers – Double Hull: Typical transverse section of a double hull oil carrier above 150,000 dwt indicating longitudinal and transverse members.....	546
FIGURE 3	Thickness Measurement – Oil Carriers – Double Hull: Transverse section outline to be used for longitudinal and transverse members where the diagrams in Figure 1 and Figure 2 are not suitable.....	547
FIGURE 4	Thickness Measurement – Oil Carriers – Double Hull: Areas subject to close-up survey and thickness measurements.....	548
FIGURE 5	Thickness Measurement – Oil Carriers – Double Hull: Areas subject to close-up survey and thickness measurements.....	549

FIGURE 6	Transverse Section	549
FIGURE 7	Transverse Rings in Cargo and Ballast Tanks	550
FIGURE 8	Transverse Bulkheads in Cargo Tanks.....	550
FIGURE 9	Transverse Bulkheads in Ballast Tanks.....	551

SECTION 14 Surveys Based on Preventative Maintenance Techniques 553

1	General	553
1.1	Survey and Maintenance Intervals	553
1.2	Definitions.....	553
1.3	Optional Notation.....	554
3	Program Requirements.....	554
3.1	Age of Vessel	554
3.3	Surveys	554
3.5	Damages	555
3.7	Computerized Maintenance Management Systems	555
5	Program Description	555
5.1	General.....	555
5.3	Implementation Surveys.....	555
5.5	Machinery Status Indicators	555
5.7	Cancellation of Program	555
7	Overhauls and Damage Repairs	556
7.1	Overhauls	556
7.3	Damage Repairs	556
9	Annual Surveys and Reporting	556
9.1	Annual Confirmation Surveys	556
9.3	Owner's Annual Preventative Maintenance Report.....	557
9.5	Alternative Electronic Formats.....	557
11	Onboard Documentation.....	557
13	Planned Maintenance (PM)	557
13.1	General.....	557
13.3	PM Implementation Surveys.....	558
13.5	Administrative Requirements.....	559
13.7	Onboard Documentation	559
15	Condition Monitoring (CM)	560
15.1	General.....	560
15.3	CM Implementation Surveys	560
15.5	Administrative Requirements.....	561
15.7	Onboard Documentation	562
15.9	Special Conditions.....	563
15.11	Alternative Techniques	564
17	Reliability Centered Maintenance (RCM)	565
17.1	Application.....	565
17.3	General.....	565
17.5	RCM Implementation Surveys.....	566
17.7	Administrative Requirements.....	567
17.9	Onboard Documentation	568

18	Condition Based Maintenance (CBM)	569
18.1	General	569
18.3	Optional Notation	570
18.5	CBM Implementation Surveys	570
18.7	Administrative Requirements	570
18.9	Onboard Documentation	571
18.11	Acceptable Groupings of Condition Monitoring Techniques	572
19	Information	573
21	ABS Offices Responsible for PMP and RCM	573

SECTION 15 Report on Thickness Measurement of Bulk Carriers – Double Skin (CSR and Non-CSR Vessels)..... 575

1	Instructions	575
1.1	Non-CSR Vessels	575
1.3	CSR Vessels	575
1.5	Reporting Forms	576

TABLE 1	Interpretations of Rule Requirements for the Locations and Number of Points to be Measured for CSR Bulk Carriers (Double Skin)	617
---------	--	-----

FIGURE 1	Close-up Survey and Thickness Measurement Areas.....	605
FIGURE 2	Close-up Survey and Thickness Measurement Areas Ordinary Transverse Frame in Double Skin Tank	606
FIGURE 3	Thickness Measurement – Double Skin Bulk Carriers: Typical transverse section indicating longitudinal and transverse members	607
FIGURE 4	Thickness Measurement – Ore Carriers: Typical transverse section of an ore carrier with indication of longitudinal and transverse members	608
FIGURE 5	Bulk Carriers: Transverse Section Outline.....	609
FIGURE 6	Thickness Measurement – Ore Carriers	610
FIGURE 7	Transverse Section of Double Skin Bulk Carrier	611
FIGURE 8	Locations of Measurements on Hatch Covers and Coamings	612
FIGURE 9	Locations of Measurements on Structural Members in Ballast Tanks of Double Skin Bulk Carriers (Topside or Hopper Side Tank)	613
FIGURE 10	Locations of Measurements on Cargo Hold Transverse Bulkheads	614
FIGURE 11	Locations of Measurements on Transverse Bulkheads of Topside, Hopper and Double Bottom Tanks.....	615
FIGURE 12	Locations of Measurements on Underdeck Structure.....	616

SECTION 16 Thickness Measurement and Close-up Survey Requirements at Special Periodical Surveys..... 619

TABLE 1	Thickness Measurement Requirements at Special Periodical Surveys for Vessels without ESP and ESDC Notations: Vessels Under 90 meters (295 feet) in Length; Passenger Vessels and High Speed Craft Under 61 meters (200 feet) in Length.....	621
TABLE 2	Thickness Measurement Requirements at Special Periodical Surveys for Vessels without ESP and ESDC Notations: Non ESP Tankers, Gas and Independent Tank Carriers 90 meters (295 feet) and over in Length.....	622
TABLE 3	Thickness Measurement Requirements at Special Periodical Surveys for Vessels without ESP and ESDC Notations: Vessels 90 meters (295 feet) and over in Length; Passenger Vessels and High Speed Craft 61 meters (200 feet) and over in Length	624
TABLE 4	Thickness Measurement Requirements at Special Periodical Surveys: Barges other than Oil/Fuel Oil Tank Barges and Chemical Tank Barges	625
TABLE 5	Thickness Measurement Requirements at Special Periodical Surveys: Oil/Fuel Oil Tank Barges and Chemical Tank Barges under 122 meters (400 feet) in Length.....	626
TABLE 6	Thickness Measurement Requirements at Special Periodical Surveys: Bulk Carriers – Non Double Skin ESP and Bulk Carrier Features of Combination Carriers – Non Double Skin ESP	627
TABLE 7	Minimum Requirements for CLOSE-UP Examination at Special Periodical Surveys: Bulk Carriers – Non Double Skin ESP and Bulk Carrier Features of Combination Carriers – Non Double Skin ESP	629
TABLE 8	Thickness Measurement Requirements at Special Periodical Surveys: Tankers ESP (Oil Carriers and Oil Carrier Features of Combination Carriers – Non-Double Hull) and Oil/Fuel Oil Tank Barges – Non Double Hull and Chemical Tank Barges 122 meters (400 feet) and over in Length.....	631
TABLE 9	Minimum Requirements for CLOSE-UP Examination at Special Periodical Surveys: Tankers ESP (Oil Carriers and Oil Carrier Features of Combination Carriers – Non-Double Hull) and Oil/Fuel Oil Tank Barges – Non Double Hull and Chemical Tank Barges 122 meters (400 feet) and over in Length.....	633
TABLE 10	Thickness Measurement Requirements at Special Periodical Surveys: Tankers ESP (Oil Carriers and Oil Carrier Features of Combination Carriers – Double Hull) and Oil/Fuel Oil Tank Barges – Double Hull 122 meters (400 feet) and over in Length	635
TABLE 11	Minimum Requirements for CLOSE-UP Examination at Special Periodical Surveys: Tankers ESP (Oil Carriers and Oil Carrier Features of Combination Carriers – Double Hull) and Oil/Fuel Oil Tank Barges – Double Hull 122 meters (400 feet) and over in Length	637

TABLE 12	Thickness Measurement Requirements at Special Periodical Surveys: General Dry Cargo Vessels (ESDC).....	639
TABLE 13	Minimum Requirements for CLOSE-UP Examination at Special Periodical Surveys: General Dry Cargo Vessels (ESDC).....	641
TABLE 14	Thickness Measurement Requirements at Special Periodical Surveys: Bulk Carriers – Double Skin ESP and Bulk Carrier Features of Combination Carriers – Double Skin ESP.....	642
TABLE 15	Minimum Requirements for CLOSE-UP Examination at Special Periodical Surveys: Bulk Carriers – Double Skin ESP and Bulk Carrier Features of Combination Carriers – Double Skin ESP.....	644
TABLE 16	Thickness Measurement Requirements at Special Periodical Surveys: Chemical Carriers ESP.....	646
TABLE 17	Minimum Requirements for CLOSE-UP Examination at Special Periodical Surveys: Single Hull Chemical Carriers ESP.....	647
TABLE 18	Minimum Requirements for CLOSE-UP Examination at Special Periodical Surveys: Ore Carriers.....	649
TABLE 19	Minimum Requirements for CLOSE-UP Examination at Special Periodical Surveys: Double Hull Chemical Carriers ESP.....	650
SECTION 17	Survey of Portable Industrial Modules	652
1	General	652
3	Container Box used as an Industrial Module.....	652
3.1	Stacked Container Boxes used as Portable Modular Units	652
5	Survey of Portable Industrial Modules.....	652
7	Certification of Vessel Fitted with Portable Modular Units.....	653

PART

7

APPENDIX

SECTION 1 Underwater Inspections in Lieu of Drydocking Surveys (2013)

1 Introduction

1.1 Scope and Application

A request for Underwater Inspection may be accepted as an alternative to Drydocking Inspection provided that all arrangements and equipment meet the requirements specified in this Appendix.

For vessels 15 years of age or over and subject to the Enhanced Survey Program (ESP), Underwater Inspections in Lieu of Drydocking are not permitted as an alternate Drydocking Surveys.

This Appendix contains the minimum requirements for an Underwater Inspection in Lieu of Drydocking. Additional specific requirements for the **UWILD** Class Notation are noted accordingly.

1.3 Approval Procedure for UWILD Class Notation

An ABS optional notation, **UWILD**, for Underwater Inspection in Lieu of Drydocking, may be assigned to a vessel in full compliance with the requirements as specified in this Appendix. The entire procedure for assignment of the **UWILD** notation is shown in 7-A-1/Figure 1.

Specific additional elements required for **UWILD** notation include the following:

- i) Preparation and submission of plans to ABS Engineering as noted in 7-A-1/3.3.5 “Plans and Data” and 7-A-1/3.5 “Physical Features”.
- ii) Out of water survey to verify hull markings.
- iii) Bolted access plates are required to be provided to determine the condition and clearance of the rudder bearings, and the physical condition and securing arrangements of the pintle as noted in 7-A-1/3.5.2.
- iv) Hinged sea suction grids for access to sea chest and sea suction openings as noted in 7-A-1/3.5.3.
- v) Hull markings or other means to orient the diver as noted in 7-A-1/3.3.5.

1.5 Governmental Regulations

The requirements specified in this Appendix are for classification only. Flag Administrations may have specific regulations for Underwater Surveys in Lieu of Drydocking, including requirements for enrollment, hull markings, extent of visibility and procedures for older vessels.

FIGURE 1
Approval Procedures for UWILD Class Notation (2010)

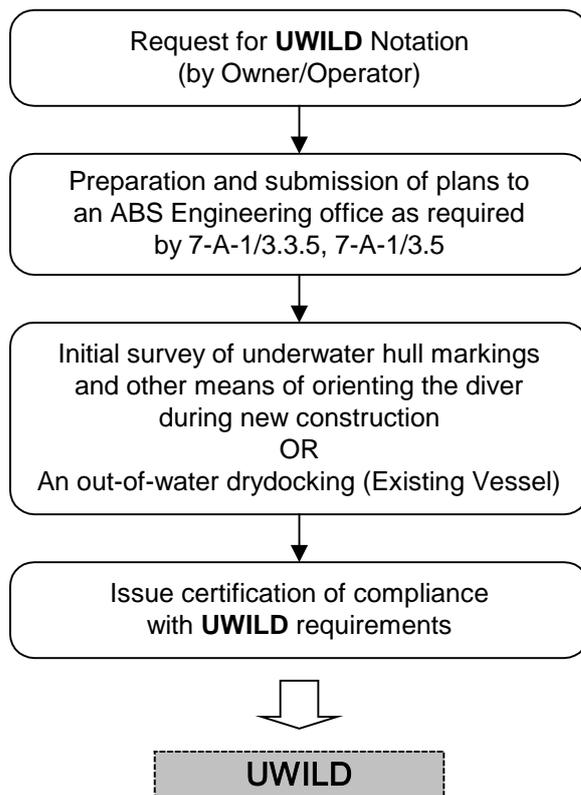

3 Conditions and Procedures

3.1 General

At the request of the Owner, ABS may consider Underwater Inspection in Lieu of Drydocking Survey provided all arrangements and conditions meet the requirements of this Appendix.

All requests for Underwater Inspection in Lieu of Drydocking Survey are to be forwarded to the applicable ABS Divisional Assistant Chief Surveyor's Office for review and authorization.

Underwater inspection is to be carried out under the surveillance of the attending Surveyor by an in-water survey company recognized by ABS.

The Surveyor is to be satisfied with the method of pictorial representation, and a good two-way communication between the Surveyor and divers is to be provided.

If the Underwater Inspection reveals damage or deterioration that requires further attention, the Surveyor may require that the vessel be drydocked in order to undertake a detailed survey and necessary repairs.

The extent of the underwater inspection is to be sufficient to include all items which would normally be examined if the vessel was on drydock, some of which are listed in 7-A-1/3.7.2.

The following Paragraphs describe the conditions and procedures under which a properly conducted underwater inspection may be credited as an alternative of Drydocking Survey.

3.3 Conditions

3.3.1 Limitations

- i) Non-ESP vessels 15 years of age or over applying for Underwater Inspection in Lieu of Drydocking are subject to special consideration based on the following review and examination before being permitted to have underwater inspection:
 - Review of vessel's records to verify that no unapproved repairs have been made
 - Internal examination of representative tanks and cargo holds
- ii) Underwater Inspection In Lieu of Drydocking Survey may be restricted or limited where there is record or indication of abnormal deterioration, existing recommendation, or damage to underwater body, rudder, or propeller.

3.3.2 Existing Outstanding Recommendations

Underwater Inspection in Lieu of Drydocking may not be applicable if there are outstanding recommendations for repairs to propeller, rudder, stern frame, underwater structure, or sea valves. It may also be inapplicable if damage affecting the fitness of the vessel is found during the course of the survey.

3.3.3 Thickness Measurements and Nondestructive Testing

Underwater or internal thickness measurements of suspect areas may be required in conjunction with the underwater inspection. Means for underwater nondestructive testing may also be required for fracture detection.

Note Thickness measurements of the hull underwater body, as required for Special Periodical Survey, are to be taken at drydock in conjunction with visual inspection of the bottom plating by the Surveyor.

3.3.4 Tailshaft Surveys

Tailshaft Surveys are not covered by this Appendix and are to be dealt with in accordance with Chapter 5 of the *ABS Rules for Survey After Construction (Part 7)* and other applicable Rules.

3.3.5 Plans and Data

Plans showing the following items are to be submitted to the attending Surveyor, together with the proposed inspection procedures for review, well in advance of the inspection.

- i) Location of bottom shell seams and butts (Shell Expansion), including any doublers, straps, bottom plugs, appendages and all underwater openings.
- ii) Hull markings or other means to orient the in-water survey and identifying photographs, which entail specific areas of plating, (e.g., locations of bulkheads or tanks) sea suction and discharge openings, propeller blades and rudder surfaces. Such preparations may include a weld bead or center punch grid system on the hull, a contrasting color coating system, a movable grid, or an acoustic locating system. Other suitable arrangements may be submitted for consideration. The hull markings or other means to orient the diver are requirements for the **UWILD** Class Notation.
- iii) Reference data and instructions to the diver for any necessary underwater operations such as means of access to sea chests to inspect the external side of hull connections and sea valves, to rudder bearings to determine clearances of rudder bearings or to propeller shaft strut and stern bearings.
- iv) Most recent gaugings and gauging report from last Special Periodical Survey and the as-built scantlings for the underwater body.

3.3.6 Underwater Conditions (2013)

- i) The in-water visibility and the cleanliness of the hull below the waterline is to be clear enough to permit a meaningful examination which allows the Surveyor and in-water survey to determine the condition of the plating, appendages and the welding. Additional cleaning may be necessary. Overall or spot cleaning may be required at the discretion of the attending Surveyor.
- ii) Where possible, the underwater examination should be carried out in protected waters, preferably with weak tidal streams and currents.

3.5 Physical Features

The following physical features are to be incorporated into the vessel's design in order to facilitate the underwater inspection. Access and provisions must be made to determine stern bearing and rudder bearing clearances. When verified, they are to be noted in the vessel's records for reference at subsequent surveys.

3.5.1 Stern Bearing

- i) Means are to be provided to ascertain that the seal assembly remains intact on oil-lubricated bearings and to verify that the clearance or wear-down is within limits on the stern bearing.
- ii) For oil-lubricated bearings, this may only require the review of operating history and onboard testing, including accurate oil-loss records and a check of the oil for contamination by sea water or white metal and/or oil sample reports (considerations are to be included in the proposals for Underwater Inspection In Lieu of Drydocking). For wood or rubber bearings, an opening in the top of the rope guard and a suitable gauge or wedge is sufficient for checking the clearance.
- iii) Any doubt on wear-down of oil-lubricated metal stern bearings from above examinations and review is to be further checked by external measurements or by the vessel's wear-down gauge, where the gauge wells are located outboard of the seals or the vessel can be tipped. For use of the wear-down gauges, up-to-date records of the base depths are to be maintained onboard the vessel. Whenever the seal sleeve is renewed or machined, the base readings for the wear-down gauge are to be re-established and noted in the vessel's records and in the survey report.

3.5.2 Rudder Bearings (2011)

Means and access are to be provided to determine the condition and clearance of the rudder bearings, and verify that all parts of the pintle and gudgeon assemblies are intact and secure. This may require bolted access plates, threaded plugs, and a measuring arrangement. Bolted access plates or threaded plugs are required for the **UWILD** Class Notation.

Where the capability does not exist for the measurement of the rudder bearing clearance when the Underwater Inspection In Lieu of Drydocking is carried out, the rudder pintle clearances portion of the survey may be specially considered by the attending Surveyor after assessment of the physical condition and securing arrangements of the pintle and review of the operating history and the onboard testing. These considerations are to be included in the proposals for Underwater Inspection In Lieu of Drydocking.

3.5.3 Sea Suctions

Means are to be provided to enable the diver to confirm that the sea suction openings are clear. Hinged sea suction grids may be used to facilitate this operation and are required for the **UWILD** Class Notation.

3.5.4 Sea Valves

Sea valves and their attachment to sea chests are to be examined externally, including expansion pieces in sea water cooling and circulating systems.

3.7 Procedures

3.7.1 Exposed Areas

An examination of the outside of the shell plating above the waterline and exposed portions of appendages, such as propeller, rudder and rudder bearings, is to be carried out by the attending Surveyor. Means are to be provided to enable the Surveyor to accomplish this visual inspection.

3.7.2 Underwater Areas

An examination of the entire vessel below the waterline is to be carried out by an in-water survey company recognized by ABS using closed-circuit television with two-way communication. The progress of the in-water survey is to be monitored by the attending onboard Surveyor as required, and can be supplemented with photographic or video documentation. Items that must be recorded on the tape/photograph include but are not limited to:

- i)* Vessel's draft
- ii)* Time at which dive commences
- iii)* Point of commencement
- iv)* Time viewed
- v)* Conditions of hull markings
- vi)* Random areas of plating
- vii)* All sea chests
- viii)* All inlets and discharges
- ix)* Rudder
- x)* Pintles
- xi)* Propeller
- xii)* Time and point of completion of the dive

The above examination is to be supplemented by the in-water survey company's report describing and attesting to the conditions found. A copy of this report and pertinent photographs are to be submitted to the attending Surveyor. Copies are also to be retained onboard.

3.7.3 Damage Areas

Damage and corrosion areas are to be taped/photographed. Internal examination or thickness gauging of such locations may be necessary, as determined by the attending Surveyor. Means are to be provided for orienting and identifying underwater surfaces in photographs, as noted in 7-A-1/3.3.5ii).

3.7.4 Planning

The equipment and procedure for observing and reporting the survey are to be discussed with the parties involved prior to the Underwater Inspection In Lieu of Drydocking, and suitable time is to be allowed to permit the diving company to test all equipment beforehand.

3.9 Alternatives

ABS is prepared to consider alternatives to the above guidelines.

3.11 Maintenance of UWILD Class Notation

For maintenance of the **UWILD** notation, a vessel's markings and equipment installed for UWILD are to be satisfactorily verified by the attending Surveyor at each Drydocking.

PART
7

APPENDIX

SECTION 2 Surveys of Voyage Repairs to Hull Structure
(2013)

1 General (2011)

The purpose of these notes is to provide guidance in dealing with voyage repairs to hull structure. Voyage repairs are repairs carried out during a vessel's voyage, typically performed by a riding crew.

ABS Rules for Surveys After Construction state in part:

Where repairs to hull, machinery or equipment, which affect or may affect classification, are planned in advance to be carried out, a complete repair procedure including the extent of proposed repair and the need for Surveyor's attendance is to be submitted to and agreed upon by ABS reasonably in advance. Failure to notify ABS in advance of the repairs may result in suspension of the vessel's classification until such time as the repair is redone or evidence submitted to satisfy the Surveyor that the repair was properly carried out.

Note: The above also applies to repairs during voyage.

Where in any emergency circumstance, emergency repairs are to be effected immediately, the repairs are to be recorded in the ship's log and submitted thereafter to ABS for use in determining further survey requirements.

The above is not intended to include maintenance and overhaul to hull, machinery and equipment in accordance with the recommended manufacturer's procedures and established marine practice and which does not require ABS approval; however, any repair as a result of such maintenance and overhauls which affects or may affect classification is to be noted in the ship's log and submitted to the Surveyor as required by above.

3 Requirements

3.1 Requirements Prior to Commencement of Repairs

A meeting is to be held with the owners prior to commencement of hull repairs during a vessel's voyage to discuss and confirm the following:

Note: All details and results of subject meeting to be covered by a memorandum. A copy of this memorandum is to be placed onboard and to be provided to attending Surveyor examining repairs. In addition, a copy is to be sent/faxed to the arrival port where completed repairs will be examined.

3.1.1

Extent of intended repairs. All repairs are to be based on ABS recommendations and/or concurrence.

3.1.2

Availability of pertinent drawings.

3.1.3

Verification of new materials regarding certification, grade and scantlings. Verified mill sheets are to remain onboard and to be provided to attending Surveyor examining completed repairs.

- 3.1.4 Verification of welding consumables regarding certification and suitability for materials involved. Check on availability of drying ovens, holding containers, etc.
- 3.1.5 Verification of the qualification of welders and supervisory personnel. Qualification records are to remain onboard and to be provided to attending Surveyor examining completed repairs.
- 3.1.6 Review of intended repair procedures.
- 3.1.7 Review of the intended provisions to facilitate sound weldments, i.e., cleaning, preheating (if applicable), adherence to welding sequence principles.
Further, it might be necessary to restrict welding to certain positions, and prohibit welding in more difficult positions when the ship's motions might influence the quality of the welding.
- 3.1.8 (2011) Review of the application of repair coating, as appropriate.
- 3.1.8 Review of intended working conditions, i.e., staging, lighting, ventilation, etc.
- 3.1.10 Review of intended supervision and quality control procedures.

3.3 Repairs

Any contemplated repairs to primary hull structure, i.e., structure affecting longitudinal strength, water tight/oil tight boundaries or stability must be submitted to ABS for review prior to commencing voyage repairs.

(2011) Voyage repairs to primary hull structures are not to be permitted except in extreme circumstances.

Any repairs to primary hull structures may require attendance by a Surveyor (riding-ship survey) to confirm fit-up, alignment, general workmanship and compliance with recommendations.

NDT of completed repairs to primary structure are to be carried out to attending Surveyor's satisfaction.

(2011) Completed repairs are to be examined and tested as required to the satisfaction of the attending Surveyor.

Repairs to secondary hull structural parts such as repairs to hold frame brackets (stevedore damages) may be accepted based on examination upon completion of repairs.

3.5 Acceptance of Repairs

Hull repairs carried out by a riding crew are not to be accepted unless:

- 3.5.1 The initial meeting had been carried out and conditions found satisfactory.
- 3.5.2 A final satisfactory examination upon completion is carried out.

PART
7

APPENDIX

SECTION 3 Vessel Lay-up and Reactivation (2013)

1 Vessel Lay-up

At the Owner's request, ABS will review, survey, and confirm by issuance of a Lay-up Report, the actions taken to preserve and protect a vessel in lay-up. Outlined below are precautions and procedures to accomplish this objective; alternative approaches to accomplish the same may be considered.

Approval Procedure for LAID UP Additional Notation

An ABS optional notation, **LAID UP** may be assigned to a vessel in full compliance with the vessel lay-up requirements as specified in this Appendix.

Specific elements required for **LAID UP** notation include the following:

- i) Preparation and submission of plans to the ABS Divisional survey office as noted in 7-A-3/1.1.3(a).
- ii) Lay-up survey
- iii) Annual lay-up confirmatory survey to be conducted in lieu of the Annual Survey – Hull:
 - a) Hull integrity
 - b) Review of vessel maintenance and preservation record
 - c) General examination
- iv) A survey report with details of vessel lay-up status.

1.1 Lay-up Surveys

1.1.1

When ABS is notified by the Owner that a vessel has been laid-up, this status will be noted in the vessel's survey status and in the *Record*, and surveys falling due during lay-up may then be held in abeyance until the vessel reactivates, at which time they are to be brought up-to-date.

1.1.2 (2011)

Where the initial lay-up preparations and procedures submitted to ABS for review and survey, and subsequently re-verified by annual survey, consideration may be given to deducting part or all of the time in lay-up from the progression of survey intervals, or to modifying the requirements for updating surveys at the time of reactivation. This consideration is not applicable to vessels in the Enhanced Survey Program (ESP) and the Expanded Survey Program for Dry Cargo Vessels (ESDC).

1.1.2(a) When lay-up specification procedures are submitted, they shall include the following details:

- Lay-up site details (location, access, meteorological data, currents and tides)
- Proposed period for lay-up
- Mooring and anchoring arrangements considering the most severe tidal changes, wind strength and direction, including provisions for clearing the anchor chain of twists
- Fendering and gangways
- Ballast requirements

- Communications with shore services
- Proposed manning
- Power availability and other services
- Fire prevention, fire fighting, flooding and securing arrangements
- Preservation of cargo gear
- Back-up, preservation or removal/storage of electronic equipment
- Preservation of hull, tanks, and cathodic protection
- Procedures for preservation and maintenance of equipment
- Use of dehumidification equipment
- Gas free certificates to be issued and maintained
- Reactivation plan
- Record of spare parts removed from the laid up vessel

A log book with record of lay-up preparations, maintenance, and preservation actions is to be maintained throughout the vessel's lay-up and reactivation. Machinery space humidity levels should be recorded on a regular basis during the lay-up period, together with scheduled equipment maintenance and operation.

1.1.3

It is the Owner's responsibility to contact Flag administrations for any specific regulations and requirements for lay-up and reactivation surveys in addition to this Appendix.

1.3 Lay-up Site and Mooring Arrangements

The following portion of the lay-up arrangements are normally subject to approval of the local port authorities, the salvage association and underwriters.

1.3.1 Lay-up Site Considerations

- 1.3.1(a)* Protection from open seas and surge.
- 1.3.1(b)* (12 June 2009) Sufficient year-round water depth.
- 1.3.1(c)* Good holding ground for anchors, clear of wrecks or cables.
- 1.3.1(d)* (12 June 2009) Clear of known cyclone, hurricane, or tidal wave lee shore.
- 1.3.1(e)* Clear of open roadstead anchorages or shipping channels.
- 1.3.1(f)* Clear of high velocity or turbulent tidal currents.
- 1.3.1(g)* Clear of significant amounts of moving ice.
- 1.3.1(h)* Clear of hazardous shore facilities.
- 1.3.1(i)* Clear of detrimental industrial waste discharges.
- 1.3.1(j)* Freezing or excess humidity.

1.3.2 Mooring Arrangements Considerations

- 1.3.2(a)* (12 June 2009) Good holding ground and ample anchor chain scope. "Ample" scope is generally considered to be seven times the depth of the water, as a minimum.
- 1.3.2(b)* (12 June 2009) Unless secured to a permanent mooring buoy, the vessel is to be moored to prevent rotating with wind or tide changes, stem towards the usual most severe winds. The chains are not to be subjected to cross-contact or twisting or the anchors to tripping. Supplemental stern mooring or anchoring arrangements are normally to be provided in addition to the ship basic anchoring equipment. Where mooring by a single anchor is necessary, provisions must be made for periodically clearing the chain of twists.

Vessels in lay-up position should be able to withstand the maximum wind loads typical of the local lay-up environmental site conditions, without reaching unacceptable loads on shore moorings or anchoring arrangements. The effect of current and tidal effects should be considered.

1.3.2(c) The chains are to be led and protected to avoid chafing against the vessel. Where the vessel is subject to sea motions, the chain is to be regularly shifted in or out a short distance to move the point of wear. At initial payout, the locking arrangement of each connecting link is to be verified.

1.3.2(d) Where vessels are moored in “rafts”, the following additional items are to be considered:

- The size and number of vessels (i.e., total windage and current drag areas) of the raft and the external forces to be expected are to be compatible with the capacity of the mooring arrangements.
- Adjacent vessels should be similar in size to avoid differential surging motion, and at similar freeboards to enable direct lead for breast lines.
- Vessels should be moored in alternate directions bow to stern in even numbers in order to provide equal anchor holding power at both ends of raft and to prevent swinging. The fore-and-aft direction should be parallel to the anticipated most severe winds.
- All ship-to-ship (breast) mooring lines should be material of similar stretch characteristics.

1.3.2(e) (12 June 2009) Ample-sized fenders or camels are to be provided alongside at areas of possible or actual contact with the service vessels, other vessels or fixed structures, including those vessels which are rafted to each other.

1.3.2(f) (2011) Day and night compass bearings and or line-up markers should be clearly established and regularly checked by the watch personnel for signs of the mooring shifting or anchor dragging. Alternative methods of confirming vessel’s position may be considered, such as the use of GPS.

1.3.2(g) Anchor lights and fog signals are to be in good order and immediately available. Supplemental deck lighting is to be used if near shipping lanes.

1.3.2(h) (12 June 2009) Tug with pumping-out equipment and firefighting assistance should be available within reasonable distance and time.

1.3.2(i) Vessel is to be ballasted with 30% or more of load draft, where possible, to reduce windage, rolling and surge, with due regard for similar freeboards where moored to other vessels. Hull stresses and salvage potential are also to be taken into account relative to ballasting. When final draft is established, clearly visible reference marks should be painted at bow and stern just above the waterline as external means of checking for leakage.

1.3.2(j) (2011) Emergency towing pendants are to be secured to bitts at bow and stern of each vessel and arranged for easy access from a tug. The emergency towing arrangement may be used if such an arrangement is provided on the vessel.

1.3.2(k) Means are to be provided for the watch personnel to release the anchors or moorings if required in an emergency. Anchors are to be buoyed for locating. The anchor windlass and any necessary mooring winches are to be fitted with emergency air connections if steam-driven or with an emergency source of power if electric-driven.

1.5 Safety and Protection

1.5.1 (12 June 2009)

There are to be sufficient and qualified personnel available in order to maintain full-time fire, leakage, moorings and security watch of the vessel. The available watchmen should include ship engineer and deck officers capable of operating the emergency communication equipment and taking emergency actions pending the arrival of outside assistance for fire extinguishing, leakage pumping, mooring adjustment or release, and general security. This includes the operation of the necessary emergency power sources, pumping units and any active fixed fire control apparatus.

In addition, efficient, independently powered fire and flooding alarms and/or warning lights within the accommodation area are to be fitted if ship is permanently manned or external alarms where it is unmanned should be fitted for the machinery space, bilges and for other spaces, as deemed appropriate.

A security plan is to be provided at the lay-up location. Plan details are to include general vessel access for crew, watch keepers, port authorities, or the use of other remote monitoring systems.

1.5.2

All the vessel's fire safety equipment including emergency fire pump are to be proven to be in good order immediately prior to lay-up and maintained, prepared for immediate use thereafter.

1.5.3 (2011)

The vessel's fire main is to be proven to be in good condition before draining. Drains are then to be kept only sufficiently open to allow drainage of condensate. Alternatively, the fire main may be filled with inhibited fresh water, including anti-freeze, if necessary. The International Shore Connection is to be loosely installed and its location prominently marked. Fire main valve stems are to be freed-up and lubricated.

The fire main is to remain in an operable condition. If the fire main isolation valves are closed and drain valves cracked open, they are to be tagged for easy identification with their location displayed outside the accommodation near the gangway.

When fire hoses, nozzles, and applicators are removed from external locations and stored in a designated deck locker or secure space inside the vessel's accommodation, these storage areas are to be identified and made readily accessible.

All fire extinguishers are to remain in their respective stations and maintained at the required service intervals. All fire hoses, nozzles, applicators, and axes located inside the accommodation and machinery spaces are to remain on station.

The vessel's fixed fire-extinguishing systems should remain fully operational during the lay-up period.

Emergency escape breathing devices are to remain in the machinery spaces and maintained as necessary.

When life jackets, survival suits, fireman's outfits, breathing apparatus, and life rings, except those needed for the crew onboard, are removed and stored in a secure space, the storage area is to be identified and made readily accessible.

All deck scuppers are to remain open, and cleared as needed on a regular schedule.

A copy of the fire control plan is to be maintained onboard and readily available.

1.5.4 (2011)

Emergency escape equipment is to be provided and maintained so that it is immediately available for the watchmen or lay-up crews.

1.5.5 (12 June 2009)

All ventilator and air intake or exhaust openings should be covered over. Supply and exhaust openings for necessary emergency diesel generator or fire pump engines should be arranged for immediate or automatic opening. All fire dampers are to be freed-up and then secured in closed position. All fire tight and watertight doors are to be closed.

1.5.6

Effective and reliable means of communication, such as independently powered radiophone, are to be provided for all-hours contact with firefighting, tug and rescue facilities, or central security base. An additional form of supplementary voice communication is to be arranged in the event of failure or damage to the primary means.

1.5.7 (12 June 2009)

A means or source of power for providing lighting, fire extinguishing water and bilge pumping throughout the ship is to be immediately available.

Where the emergency source of power is a portable diesel generator set mounted on deck, care is to be taken with respect to the fire safety of the fuel and exhaust systems, fire extinguishing arrangements, weather protection, proper electrical installation and electrical protective devices for this unit.

1.5.8

All loose flammable materials, debris, oily rags, cotton waste, chemicals, additives, corrosives, old pyrotechnics, matches, unsealed painting oils and dregs, garbage, etc., are to be removed from the vessel, above and below. Arrangements are to be made for the containment and frequent removal of garbage produced by watch personnel.

1.5.9

Empty cargo tanks, adjacent cofferdams, cargo piping system, cargo venting system and cargo pump rooms are to be clean and gas-free, or inerted. This is to be certified initially and at least weekly thereafter by qualified personnel until stabilized, after which the intervals may be lengthened. Where it is necessary to maintain a slop tank in use, safety arrangements should be specially considered.

1.5.10

Machinery space bilges are to be cleaned of all debris, oil or other flammable products and dried out.

1.5.11

All valves of fuel and lube oil tanks, except those tanks for emergency generators, are to be closed and secured by wire or pad lock.

1.5.12

All valves to or from the sea are to be closed and secured by wire, or pad lock, except those actually required for use during lay-up in connection with fire extinguishing, pumping out or watch personnel service. In order to prevent excessive fouling and choking, the sea suction openings (except for emergency fire pump) should be covered over and/or protected with an approved slow-acting biocide.

1.5.13

The vessel's anchor windlass is to be proven in good order prior to lay-up with anchors and chains checked. Where used as part of the mooring arrangements, the chains are to be regularly checked for twists and chafing, and shifted or padded, as necessary. If not required for the mooring, one anchor is to be prepared for emergency release.

1.5.14

No hot work is to be permitted during lay-up, except under specially supervised safety control. No unshielded or open-flame devices such as portable heaters are to be permitted on board. Safe smoking areas, if required, should be clearly marked.

1.5.15 (12 June 2009)

The vessel is to be readily accessible and approachable for shore-based firefighting or other emergency equipment at all times and tides.

1.5.16 (2011)

The propeller shaft is to be blocked from turning by positive means. The turning gear is not to be used for locking the propeller shaft and is only to be engaged when in use.

The rudder is also to be hydraulically locked or otherwise blocked amidships.

1.5.17 (12 June 2009)

The life boat davits, wires, rollers, and winches are to be lubricated and operated every three months. Life boat equipment should be removed, recorded, and stored in a secure room inside the vessel's accommodation. The life boat engine is to be operated once a month.

1.5.18 (12 June 2009)

If the vessel is not to be manned by regular crew then all stores should be removed from the vessel.

1.7 Preservation and Maintenance

1.7.1 Hull and Deck Equipment

(12 June 2009) The primary objective of lay-up preservation is to protect the hull and deck equipment against accelerated corrosion, weathering damage and freezing.

1.7.1(a) (12 June 2009) The vessel's external coating systems should be in good condition prior to lay-up. Consideration may be given to supplemental sacrificial anodes externally along the side shell and in ballasted tanks. Corrosion inhibitors may also be considered for use in ballast tanks.

1.7.1(b) Where fitted, impressed-current cathodic hull protection systems are to be maintained in operation if a continuous power source is available. Readings are to be logged weekly by watch personnel who are to be advised of proper procedures in case of abnormal readings. If the vessel is moored to another vessel or uses shore power, the system may need to be modified or secured to avoid possible electrolytic interaction based on manufacturer's recommendation.

1.7.1(c) Deck machinery is to be thoroughly lubricated and run in all modes before securing. Deck machinery should be turned over at least quarterly.

1.7.1(d) (12 June 2009) Water, steam, and air piping in accommodation spaces, deck, and other hull spaces is to be drained and/or blown through and air dried. Alternatively, they may be completely filled with chemically inert anti-freeze liquid compatible with the piping or tubing material under the guidance of a chemical specialist. Salt water lines, including tank washing apparatus, should be flushed out with fresh water, drained and blown dry. The needed supply of fresh water is to be available on arrival at the lay-up site.

1.7.1(e) Air vents for water tanks and fuel oil may be left open. Flame arrestor arrangements on fuel tanks and adjacent cofferdams are to be in good order.

1.7.1(f) (12 June 2009) Where possible, cargo tanks are to be kept empty and dehumidified or inerted to minimize corrosion. Otherwise, they are to be ventilated as much as possible and condensate regularly removed or inhibited. Supplemental anodes and inhibitors should be considered for cargo or ballast tanks which must remain with water in them.

The use of dehumidification systems should be considered for empty ballast tanks, void spaces, and machinery spaces.

1.7.1(g) All doors and side scuttles are to be kept closed and deadcovers in place, except where in regular use by watch personnel. Machinery casing top openings and skylights are to be kept closed and weathertight.

1.7.1(h) Hull hydraulic systems should be kept completely full of fluid. All hydraulic cylinders and ram assemblies are to be actuated at least monthly.

1.7.1(i) Wire radio antennae should be lowered and secured, except for emergency communications antenna.

1.7.1(j) All loose items on deck are to be properly secured.

1.7.1(k) All exposed navigation equipment such as gyro compass repeaters are to be stowed inside a dry compartment or at least be protected with a weathertight cover.

1.7.1(l) Galley exhaust grease collection apparatus is to be cleaned. If in use by watch personnel, it should be cleaned monthly.

1.7.1(m) (12 June 2009) Potable water tanks not in use by watch personnel should be drained and left open for free ventilation. Alternatively, they may be left completely filled and treated with water stabilizers if not subject to freezing.

1.7.1(n) All deck electrical receptacles are to be closed up weathertight. Deck mounted electrical or hydraulic controls are to be protected by a weathertight cover.

1.7.1(o) (12 June 2009) All exposed wire rope for cargo gear, except as noted in 7-A-3/1.7.1(q), should be stripped, as necessary, slushed with preservative grease and stowed out of the weather. Fibrous mooring ropes and other cordage not in use are to be stowed off the deck and out of the sun and weather.

1.7.1(p) Exposed deck fittings liable to corrosion seizing, such as hinges, clips, screw-dogs, roller fairleads, boom fittings and valve stems should be coated or injected with preservative grease.

1.7.1(q) (12 June 2009) When deck cranes remain in operation, rigging on deck cranes should be coated with grease and left rigged for use during lay-up and reactivation. Booms are to be cradled and secured. The motor and drum assembly should be fitted with protection covers and secured.

1.7.1(r) (12 June 2009) Accommodation ladders, fittings, and winches should be coated with grease and left rigged for use during lay-up. Wire drums should be fitted with protection covers and secured. The winch controller should be fitted with a lockable remote operating station on the dock.

1.7.1(s) (12 June 2009) Whenever possible, accommodation spaces, navigation bridge, and other control rooms are to be sealed and controlled by dehumidification. Complete dehumidification at 45% to 55% RH is normally required to prevent sweating or equipment damage.

1.7.2 Machinery Spaces and Machinery *(12 June 2009)*

The machinery and related engine room equipment are to be protected against accelerated or localized corrosion, seizing and freezing. This normally involves the use of stabilized or preservative lubricants, prevention of acid concentrations, and regularly scheduled rotation or movement of machinery parts to shift contact surfaces. A means or source of power for lighting and for turning over machinery is to be provided. Continuous heating for the machinery spaces, including steering gear room, to maintain a temperature a few degrees above atmospheric; or alternatively, complete dehumidification at 35% to 45% RH is normally required to prevent sweating or humidity corrosion damage.

Equipment and engine manufacturer lay-up instructions should be referenced.

1.7.2(a) All rotating machinery in the machinery spaces are to be turned over several revolutions and stopped at a new position at least once a month. Where fitted, pressure lubrication systems are to be actuated and cylinder lubricators manually operated prior to turning over the machinery. The steering gear is to be operated and moved full travel at the same intervals.

Monthly engine turning may cause removal of preservative oil from some surfaces. The surfaces are to have preservative oil re-applied as needed after the scheduled turning operations.

Main and auxiliary engines which are not in operation are to be turned once a month with their respective lube oil and pre-lube oil pumps running to provide adequate oil coverage of bearing journals. Cooling water circulation is also to be considered.

Enclosed engine compartments are to be dehumidified to avoid corrosion.

Intermediate propeller shaft bearings are to be lubricated prior to turning.

1.7.2(b) Lube oil in engines and turbines is to be thoroughly centrifuged and water separated or dehumidified prior to shutting down. After which the oil is to be periodically analyzed to confirm stability and the absence of harmful acidity. Any lube oil reservoir or sump vents exposed to the atmosphere are to be closed off and opened only to a dry space. Where lube oil tanks are contiguous with the hull plating, accumulation of condensation is to be provided for.

Lube oil water content and cooling water inhibitor level are to be checked and recorded monthly.

1.7.2(c) All other machinery should be thoroughly lubricated with a stable grease or oil before securing, and at least annually thereafter. For reciprocating units, means of non-contaminating protection are also to be provided in the cylinders.

Preservative oil is recommended to be applied to accessible machined steel surfaces both internally and externally.

1.7.2(d) The machinery spaces bilges are to be thoroughly cleaned and pumped dry. Where a water-lubricated stern bearing is fitted, the stern gland is to be tightened up just sufficiently to stop leakage, and warning notice to this effect posted at the control station.

Oily water separator chambers and oily bilge tanks should be flushed and cleaned prior to lay-up.

1.7.2(e) The sea-water side of heat exchangers is to be thoroughly cleaned of all sea growth or other organic products, washed through with fresh water, then drained, dried and closed up, or left open to a dehumidified space. Drains may be left partly open but are to be clearly marked to this effect and connecting valves to the sea wired closed. Alternatively, these heat exchangers may be kept completely filled with chemically inert liquid or a corrosion inhibitor under the guidance of a chemical specialist.

1.7.2(f) All other steam, feed, condensate or water system heat exchangers, reservoirs and piping are to be drained and blown dry. Alternatively, these may be protected by filling with a non-contaminating, chemically inert liquid, a corrosion inhibitor, or dry inert gas. This process is to be carried out under the guidance of a chemical specialist.

1.7.2(g) Air starting tanks are to be fully charged, water drained and air outlet valve closed off at the tank. Alternatively, they may be opened, cleaned, dried and left open for free ventilation.

1.7.2(h) The ship's air conditioning and refrigeration systems should be pumped down and secured. If refrigeration or air conditioning equipment contains ozone depleting substances, consideration should be given to pumping the system gas to a storage cylinder to avoid leakage to atmosphere during lay-up when equipment is shut down.

Inert gas systems are to be completely drained, dried out, and secured with means for air circulation or dehumidification. Acidic areas may require to be neutralized.

1.7.2(i) Fuel oil systems are to be treated with a stabilizer and a fuel dispersant, under the guidance of a chemical specialist.

1.7.3 Boilers

1.7.3(a) The boiler fire-side including superheater, economizer and air heater, prior to lay-up are to be thoroughly cleaned in order to minimize external acidic corrosion from the absorption of atmospheric moisture by the products of combustion. Usual soot accumulation areas such as where tubes enter headers or water drum and around floor tubes require special attention. If water washing is resorted to for cleaning, the boiler should then be fired for about 12 hours to dry the residual moisture from the insulation and brickwork. Where feasible, however, an alkaline wash water should be used. Final cleaning by dry method is recommended, after which the furnace openings should be left open for free ventilation.

1.7.3(b) The boiler water-steam side may be preserved by a wet method or a dry method. In either case, the water-steam side of the entire boiler, including superheater and economizer, is to be first washed clean of all residue and existing chemical concentrates.

Where the dry method is employed, after thoroughly heat drying, the water-steam side of the boiler is to be either charged with trays of desiccant and resealed, or left open top and bottom, including a handhole in each header, for free ventilation to a dehumidified space or with a continuous source of heating inside the water drum. If desiccant is used, this is to be renewed or re-dried at least monthly or changed on the basis of a moisture indicator. A third alternative is to keep the boiler empty, sealed and slightly pressurized with a dry inert gas.

Where the wet system is employed, the entire boiler, and possibly the feed and condensate systems, should be kept full under a slight head with chemically inert distilled water. The initial charging and occasional rechecks are to be carried out under the guidance of a chemical specialist. If the wet system is employed, external space heating or dehumidification may be required to control sweating and consequent poultrice corrosion under insulation.

1.7.4 Stack Openings

After securing the boiler and engines, all stack outlets are to be covered over weathertight. If not in use, the galley stack is also to be covered over.

1.7.5 Electrical Installation

The electrical system is to be protected against insulation deterioration, primarily from moisture absorption or water ingress, and the rotating elements protected against corrosion damage in the bearings.

(12 June 2009) Electronics are better protected with constant power applied in a warm and dry environment. Sealed and de-humidified ships also preserve equipment longer. Desiccant should be placed inside all electrical units to avoid the risk of condensation. Desiccant should be changed at manufacturer's recommended intervals. Open cable ways should be sealed to reduce desiccant degradation and other component damage.

1.7.5(a) Before securing, electrical motors and generators should be thoroughly cleaned of carbon or other hygroscopic foreign matter, heat dried so as to obtain acceptable insulation resistance readings, and the bearings lubricated with a stable grease or oil. Any carbon brushes should be lifted to prevent spot corrosion on the commutator or slip rings. Insulation readings are to be taken and recorded at least monthly thereafter and where found abnormal, immediately corrected by heating, drying or cleaning.

1.7.5(b) All electrical apparatus should be maintained internally a few degrees above atmospheric by means of built-in heaters, or by other means such as strip heaters or heat lamps. Alternatively, the humidity control may be maintained by opening the unit to the effects of a dehumidifier or by sealing the unit with desiccant inside. This latter approach requires replacement of the desiccant and re-sealing at least monthly or based on a moisture indicator.

1.7.5(c) *(12 June 2009)* The gyrocompass, radar, radio and automation electronic apparatus are to be maintained heated and/or dehumidified in the same manner as above. The manufacturer is to be consulted regarding the maintenance during lay-up of computer systems and other electronic apparatuses. Such equipment may require to be operated monthly. Radar and other electronic equipment configurations may require being saved/backed up. Desiccant may be required to be installed in the display or the processor as per manufacturer instructions. Desiccant should be changed at manufacturer's recommended intervals.

Electronic navigation equipment operated by a computer or a computer network may require configurations and settings to be saved on a separate computer system or external hard drive prior to switching off. License permits and program updates may lapse during lay up, so the final program status should be recorded. Dust covers should be placed on electronic equipment.

During the lay-up period there may be considerable marine growth on the speed log and echo sounder transducer face. When the transducer is fitted with a gate valve, the transducer may be replaced with a dummy transducer.

1.7.5(d) *(12 June 2009)* All liquid-filled storage batteries are to be fully charged and, if possible, maintained on trickle charge under weekly inspection.

If batteries are not trickle charged then they are to be disconnected. GMDSS main batteries and UPS units are to be fully charged and disconnected. Battery terminal posts and cable clamps are to be greased for preservation. End of use dates are to be recorded on all batteries for replacement at reactivation.

1.7.5(e) All electrical switches for circuits not in regular use are to be kept in open or disconnect position.

3 Reactivation of Laid-up Ships

Laid-up vessels are required to undergo a Reactivation Survey prior to returning to active service regardless of whether ABS has been previously informed that the vessel has been in lay-up. The requirements for the Reactivation Survey are to be specially considered in each case based on the status of surveys at the time of lay-up, the length of the lay-up period, and the conditions under which the vessel has been maintained during that period. For details of the requirements, contact an ABS office. Outlined below are guidelines on such surveys.

3.1 Reactivation Survey Status

3.1.1

In order to restore a laid-up vessel to active Class status, a Reactivation Survey is to be carried out including a corresponding point-by-point coverage of the original lay-up items. The extent of the Reactivation Survey is generally dependent on the length of the lay-up, the lay-up procedures followed, and the maintenance conditions during lay-up. However, the equivalent of an Annual Survey for all Class items, up-dating any due surveys and compliance with any outstanding recommendations are normally required.

3.1.2 (12 June 2009)

The primary objective of the Reactivation Survey is to verify that the vessel is in conformance with the applicable class Rules and requirements. Where the lay-up preparations and procedures were submitted to ABS for review and verified by survey at time of lay-up and annually thereafter, consideration may be given to deducting part or all of the time in lay-up from the progression of survey intervals, or to modifying the requirements for up-dating surveys at time of reactivation.

3.1.3 (12 June 2009)

Applicable items of the Reactivation Survey may be credited to a forth coming Special Periodical Survey, provided that the entire Special Periodical Survey is completed within a period of approximately fifteen months, or the Special Periodical Survey is on continuous basis.

3.3 Reactivation – Hull and Outfit

3.3.1 (12 June 2009)

Drydocking Survey – Dependent upon the date of the last Drydocking Survey and the period and conditions of lay-up, an underwater inspection by diver may be permitted in lieu of drydocking for reactivation. In such cases, cleaning of vessel's underwater body, including sea suction, may be required. Where it is intended to proceed from the lay-up site to another location for drydocking, an underwater inspection by diver will normally be required prior to departing the lay-up site.

3.3.2

The following additional items are normally to be included in the reactivation surveys of hull and outfitting:

- Anchors and chain cables, chain stoppers and chain locker pumping arrangements
- Anchor windlass, mooring winches and roller fairleads
- Cargo holds and machinery space drain wells together with bilge pumping arrangements and hull penetrations
- Random cargo tanks, pump rooms, cargo piping and associated valves and pumping arrangements
- Watertight doors, engine room skylights, fire dampers, ventilators, portlights, hatch covers and their respective closing devices
- Peak tanks, random ballast tanks and their respective pumping systems
- Cofferdams and voids, together with their pumping out arrangements
- General examination and testing of ship's whistle, internal communication systems, engine order telegraph, steering arrangements and controls, general alarm system, rudder angle indicator and navigational lights

- Examination and servicing as necessary of ship's radio installation, radio direction finder, gyro-compass and repeaters, magnetic compasses, depth sounder, radar and other navigational aids
- Fire extinguishing arrangements to be verified in order
- (12 June 2009) Foam tank solution to be tested and replaced as necessary
- Tank venting arrangements including closing devices, pressure-vacuum relief valves and flame arrestors to be examined and placed in order as required

3.5 Reactivation – Machinery

3.5.1

Stack and ventilation covers are to be removed or opened up.

3.5.2

Boilers, heat exchangers, piping systems and other equipment are to be drained and cleaned of preservatives or inhibitors, inspected and closed up in good order. Afterwards to be tested under operating conditions.

3.5.3

Engine lubricating oil, stern bearing oil and steering system hydraulic fluids are to be analyzed for contamination or chemical degradation and if found unserviceable, the system is to be drained, flushed, sterilized if bacterial deterioration is present and refilled with new oil or fluid of the proper grade.

3.5.4

Turbine rotor journal and thrust bearings are to be at least selectively examined for corrosion effects, clearances checked and dealt with as necessary. Functional operation of seals, drains; low-oil-pressure, manual and overspeed trips are to be confirmed. The turbines may require being opened and checked for corrosion or other deterioration.

3.5.5

Reduction and reverse gearing is to be examined as accessible via inspection openings including lubrication arrangements. Gear casing and foundations are to be examined and reversing and braking arrangements operationally tested.

3.5.6

Thrust bearings, lineshaft bearings and their respective lubrication arrangements are to be checked.

3.5.7

Diesel engines and their accessory gear are to be selectively opened out and examined for corrosion, excess wear, damage, proper tensioning and torquing. Crankshaft deflections are to be taken and recorded. Protective trips and alarms are to be verified.

3.5.8

All essential auxiliary machinery and equipment are to be operationally tested, protective devices verified.

3.5.9 (12 June 2009)

All essential piping systems are to be examined under pressure, checked for leaks, and overpressure relieving arrangements verified. All connections to the sea and their respective valves and non-metallic expansion pieces are to be examined.

3.5.10 (12 June 2009)

All required fire extinguishing arrangements are to be reconnected and examined, including fire pumps and fixed extinguishing systems, and tested as necessary.

3.7 Electrical

3.7.1

Insulation resistance of all power and lighting circuits together with generators, motors and switchgear, are to be tested, results evaluated and low-reading components dealt with as necessary.

3.7.2

Generators are to be tested under operating conditions, and switches, circuit breakers and electrical protective devices verified.

3.9 Control and Instrumentation

3.9.1

All essential control systems, monitoring instrumentation, limit alarms and emergency shut-offs are to be verified in order.

3.11 Trials

In addition to the operational tests of individual units of machinery, a dock trial, and subsequent sea trial if deemed necessary, should be effected to the satisfaction of the attending ABS Surveyor.

3.13 Documentation and Certification

3.13.1 (12 June 2009)

The validity of the various statutory or trading documents such as the Cargo Gear Register, the Safety Construction, Safety Equipment, Safety Radio, Loadline, Oil Pollution Prevention, Air Pollution Prevention, Dangerous Chemicals and Liquefied Petroleum Products Certificates are to be checked and updated or renewal surveys carried out, as necessary. Verify that all required statutory documents including oil record book, SOPEP plan, engine technical files, engine record book of engine parameters, are in place as required and up to date.

For ships out of service for more than three months, ISM and ISPS audits will be required.

3.13.2

Notwithstanding that certain statutory certificates are still valid at the time of the Reactivation Survey, if they have been issued by ABS, at least a general examination of the covered items will be required.

3.13.3

Possible changes or revisions in international convention requirements since the time of lay-up or in the interpretations of same by the registry Administration should be checked.

3.15 Additional Items for Consideration

In addition to the foregoing, consideration should be given to the following items at time of reactivation:

- Necessary supplies, spare parts and consumables
- Cleaning, recoating and flushing potable water tanks
- Internal corrosion removal and recoating
- Mooring lines and hawsers
- Gangways and boarding ladders
- Cargo gear
- Specialized equipment related to the type of cargo carried such as tank filling instrumentation or gas leak detection apparatus

PART

7

APPENDIX

SECTION 4 Additional Information for Hull Thickness Measurement (2013)

1 Purpose

The purpose of thickness measurement is to establish, in conjunction with a visual examination, that the condition of the existing structure is, or will be after the required repairs, fit for continued service during the subsequent survey interval. The gauging requirements include measurements which are used to verify remaining longitudinal strength, transverse sections, as well as measurements of areas known to be potential problem areas, main deck plates and wind and water strakes. Thickness measurements are a tool used to assess ship structure, not a stand-alone method of inspection. Thickness measurements are a confirmation of conditions sighted by the Surveyor. When a Surveyor confirms that a set of thickness measurements are representative of the conditions found, he can only do so if he personally examined and selected the particular areas to be measured, and is satisfied they actually represent the conditions of the structure involved and not the thickness in way of isolated pits or localized corrosion. Local pits and corrosion are to be dealt with as necessary by the Surveyor.

3 The Thickness Measurement Process

When an Owner requests attendance for a survey with thickness measurements due, the Surveyor is to obtain scantling drawings, either from the Owner or from ABS files. The Surveyor will advise the Owner of the thickness measurement requirements and of the requirement to use an ABS-approved company to take the thickness measurements.

The Surveyor is to attend the vessel while thickness measurements are being taken in order to advise the Owner of the locations. The Surveyor is to regularly review the thickness measurement results, in order to promptly advise the Owner of any additional readings which are to be taken to confirm marginal conditions or the accuracy of questionable readings. When multiple readings are taken to confirm marginal or questionable readings, the Surveyor will determine and report the single reading which he feels, based on his observations, represents the average condition of the plate in question.

A corrosion pattern may be localized, may be uniformly present on an individual plate or may cover an entire bottom of a tank. An individual reading does not constitute a corrosion pattern. One marginal reading would require additional readings to be taken and assessed together with close visual examination by the Surveyor for determination of extent of corrosion pattern. When multiple readings are taken or marginal readings encountered, the Surveyor must make an assessment of the average condition based on observations of the structure from visual examination and the gauged readings.

5 Thickness Measurement Review

First, the Surveyor is to verify that all thickness measurement requirements for the applicable survey are met. Any required measurements which have not been taken, will be noted in his report as an item remaining to be completed before the survey can be credited.

Next, the Surveyor is to check that all individual plate thickness measurement results are within ABS allowances. For wastage allowances, refer to 7-A-4/Table 1 "Individual Plate Wastage Allowances, Conventional Vessels 90 M and Over built to ABS Class", 7-A-4/Table 2 "Steel Wastage Allowances, Conventional Vessels Under 90 M (295 Feet)" and 7-A-4/Table 3 "Aluminum Wastage Allowances, Conventional Vessels Under 90 M (295 Feet) built to ABS Class" of this Section.

For unconverted, conventional type vessels built to ABS Class, wastage allowances are to be applied to the as-built thickness.

For vessels built with reduced scantlings (see *Record Comments*), the wastage allowances are to be applied to the ABS Rule-required thickness shown on the vessel's approved drawings. Care must be taken to distinguish between the reduced as-built scantling and the ABS Rule required scantling.

For special type vessels, former military type vessels, vessels originally built to another Society (with no Maltese Cross), vessels accepted under SVR 1-1-4/7 (see *Record Comments*), and for converted or lengthened vessels (see *Record*), wastage allowance is obtained from an ABS Technical Office or the vessel survey status (if noted on the status).

To request a thickness measurement review based on other than as-built thickness or a scantling reassessment, the Owner is to contact an ABS Technical Office.

Finally, the Surveyor is to check the average wastage of the top and bottom transverse sections. If individual plates are to be renewed, this average is to be checked with the renewed plate thickness. For ease of check, the plates and internals are to be averaged separately.

The top of the transverse section includes the deck plating, stringer plate and sheer strake. The bottom of the transverse section includes the flat keel plating, the bottom plating, and bilge plating. The internals are those longitudinal members attached to the aforementioned plates.

The average wastage is a simple, arithmetic average of the individual plate or internal wastage percentages. For example, assume there are seven (7) plates in a top section with individual plate wastages of 12%, 16%, 18%, 13%, 19%, 11% and 17%. The average wastage of the top section of plating is $(12 + 16 + 18 + 13 + 19 + 11 + 17)$ divided by the number of plates, seven (7), which equals 15.1%.

If the average wastage of either the top section, bottom section, or internals of those sections exceeds 10%, and the situation cannot be resolved locally, an ABS Technical Office will be contacted for assistance. Because time is of the essence during a repair period, the Technical Office is expected to reply promptly to enable Owners to complete any necessary steel renewals or modification.

An ABS Technical Office, not the Surveyor, will carry out area loss or buckling checks, if necessary.

7 Thickness Measurement Reports (1 July 2013)

Survey reports for vessels subject to the Enhanced Survey Program (ESP) are to be prepared following the format contained in Section 7-A-6, "Reports on Thickness Measurement of Bulk Carriers", Section 7-A-7, "Reports on Thickness Measurement of Oil Carriers, Ore/Oil Ships and Chemical Carriers – Non Double Hull", Section 7-A-13, "Reports on Thickness Measurement of Oil Carriers, Ore/Oil Ships and Chemical Carriers – Double Hull", or Section 7-A-15, "Report on Thickness Measurement of Bulk Carriers – Double Skin", of this Appendix. Reports for other vessels are to clearly present the location, original thickness, measured thickness and percent wastage.

The attending Surveyor will review the results for accuracy and completeness and endorse the report with the vessel's name, ABS ID, date and his signature to indicate the results are considered representative of the actual condition of the vessel.

9 Thickness Measurement Company Approval Requirements (1 July 2014)

Persons or companies not employed by ABS who act at the request of the Owner to take ultrasonic thickness measurements on Enhanced Survey Program (ESP) vessels; and non-ESP/ESDC vessels 90 meters in length and over for classification or statutory surveys, must be approved by ABS in accordance with ABS procedures for approval of External Specialists. (See Section 7-A-5, "Procedures for Certification of Firms Engaged in Thickness Measurement of Hull Structures".)

The local ABS office can provide the Owner with a list of approved companies in that office's area. ABS does not recommend or endorse any specific company and it is entirely up to the Owner to select the company.

11 Thickness Measurement Requirements and Locations

The thickness measurement requirements for Annual and Intermediate Surveys are based on the conditions found at the time of survey, as well as conditions documented at the previous Special Periodical Survey. Thickness measurement requirements for Special Periodical Survey are based on age, size and type of vessel. The minimum thickness measurement requirements are contained in the applicable ABS Rules and Guides. For vessels subject to the ESP, thickness measurements for Special Periodical Survey are to be dealt with in the required Survey Planning Document.

In all cases, the Surveyors have the discretion to require thickness measurements to supplement their visual examinations where there is any doubt of the structure's fitness for continued service.

The Surveyor will indicate the locations to be measured. Transverse sections should be in one section, not over several frame spaces. The sections should be located where the largest reductions are suspected to occur or are revealed from deck plating thickness measurements. Where possible, locations different from those measured at previous Special Periodical Surveys should be selected.

13 Thickness Measurements of Structural Members Subject to Close-up Survey

Close-up Surveys are required for Special Periodical Survey of vessels subject to ESP, and may also be required at Annual and Intermediate Surveys. At Special Periodical Survey, thickness measurements of structural members subject to Close-up Survey are required for general assessment and recording of corrosion patterns.

15 Modification of Thickness Measurement Requirements

In general, thickness measurement requirements of internals may be modified for vessels with acceptable, corrosion-resistant, hard-type coatings, such as epoxy or zinc, providing that after a careful examination, the Surveyor can verify the continued effectiveness of same. No consideration for reduced thickness measurements will be given for soft type coatings.

Where there is evidence that the coating is no longer intact (such as heavy staining, blistering, cracking, peeling or bare spots), the Surveyor must require sufficient confirmatory thickness measurement to clearly establish the condition of the internals. Please note that in the initial stages of coating breakdown, the corrosion may proceed at a very high rate in the exposed spots due to the abnormal area ratio between the protected and unprotected surfaces.

For vessels subject to ESP, thickness measurements for general assessment of corrosion patterns of structural members subject to Close-up Surveys are required at Special Periodical Survey. Up to and including Special Periodical Survey No. 2, the Surveyor may modify the extent of thickness measurements of these structural members where the coating is found in "GOOD" condition, as defined in ABS Rules. The Surveyor will specifically examine and report on the coating condition, and take a number of confirmatory thickness measurements to support his recommendation to modify the extent of thickness measurement of these structural members.

After Special Periodical Survey No. 2, modification of the extent of thickness measurements of these structural members is to be specially considered. The Surveyor will submit his findings on the coating condition and the confirmatory thickness measurements, along with sufficient photos to support his recommendation, for special consideration. Normally, the Divisional Assistant Chief Surveyor will examine the Surveyor's submittal and either accept or reject the Surveyor's recommendation to modify the extent of thickness measurements.

For converted vessels, the Special Periodical Survey and the thickness measurement requirements are based on the age of the original, retained sections. However, the thickness measurement requirements for the new body sections may be in accordance with Special Periodical Survey requirements for a vessel of corresponding age.

17 Additional Thickness Measurements and Substantial Corrosion

The Surveyor will specify additional thickness measurements in areas of known or suspected wastage. During the thickness measurement process, the Surveyor will also advise the Owner if any additional readings are to be taken to confirm questionable readings or marginal conditions.

Substantial Corrosion is defined as, “an extent of corrosion such that assessment of corrosion pattern indicates wastage in excess of 75% of the allowable margins, but within the acceptable limits”. An individual reading does not constitute a corrosion pattern. A single, marginal reading requires additional readings to be taken and evaluated together with close visual examination by the Surveyor in order to determine the extent of the corrosion.

For example, assume the individual plate wastage allowance for plates in the transverse bulkhead of a tanker is 25% and the original thickness of the plate in question was 12 mm, the following illustrates the wastage limits:

- For a gauged thickness of 9.75 to 12 mm, the percent diminution was 18.75% (i.e., 75% of 25%) to 0%, therefore, the plate had some corrosion.
- For a gauged thickness of 9.0 to 9.75 mm, the percent diminution was 25% to 18.75%, therefore, the wastage of the plate was in substantial corrosion range.
- For a gauged thickness of less than 9.0 mm, the percent diminution was greater than 25%, therefore, the wastage of the plate was in renewal limit.

The concept of defining substantial corrosion serves two purposes. First, once a thickness measurement reading reaches a critical wastage range (by substantial corrosion definition, 75% of allowable wastage), the accuracy of that reading is more crucial in determining the appropriate recommendation. Accordingly, when substantial corrosion is found, the number of readings must be increased, as required by 7-3-2/7.

The second purpose of defining substantial corrosion is to provide guidance on additional areas to extend thickness measurements once an area of substantial corrosion has been identified. Thickness measurements are to be extended into the areas as noted in 7-3-2/7. Using the approach of varying the density of readings in a particular area depending on the thickness loss being encountered, the full five point pattern described is not required unless initial assessment results in readings with wastage in the substantial corrosion range.

In assessing the overall condition, it should be borne in mind that where wastage limits are based on a percentage, thinner members will reach the limit sooner, assuming the material loss rate per surface is the same. Also, where both surfaces of a member are exposed to the same wastage conditions, the limit will be approached at double the normal rate. For instance, internals in tankers, since they are exposed to cargo tank corrosion on both surfaces and because they are often originally thinner than the plating in the same area, usually reach the limiting wastage much earlier than the plating. Accordingly, if substantial corrosion is found on plating, additional thickness measurements should be extended not only to surrounding plating, but also to internal members. Likewise, when substantial corrosion is identified on internals, additional thickness measurements are to be extended to other similar and thinner internals.

As an example, consider the bottom structure. Bottom shell plating and longitudinal members are gauged across a transverse section in way of aftmost bay of a wing tank. Each plate and longitudinal member on the transverse section is required to be gauged. If the readings identified one bottom strake with wastage in the substantial corrosion range, the following actions would be required:

- For the one identified strake, the number of readings must be increased, as required by 7-3-2/7. This will require a five point-pattern of thickness measurements to be taken on each panel of the strake within the bay. This high density of readings will provide a higher degree of accuracy in determining the corrosion pattern and will provide more information to establish appropriate recommendations for extent of repair, if required.
- Bottom shell thickness measurements are to be extended, as required by 7-3-2/7. This will require the bottom shell in way of two other bays to be measured with the minimum thickness measurement pattern. If vessel is undergoing Special Periodical Survey No.4 – Hull or greater, all bottom plates will have been measured as a baseline requirement. If the minimum thickness measurement pattern indicates wastage in the substantial corrosion range, thickness measurements should be increased to the five-point pattern per panel as above.

- No internal members were identified with wastage in the substantial corrosion range for the transverse section. However, as internals usually reach the limiting wastage much earlier than the plating, additional thickness measurements should be extended to both surrounding plating and internal members. This will require in way of the two other bays identified in above, three longitudinals in each bay to be measured with three (3) measurements in line across flange and three (3) measurements on vertical web, as noted required by 7-3-2/7. Similar action should be taken with regard to bottom girders and brackets and bottom transverse webs.

Substantial Corrosion is not an outstanding recommendation, but areas of Substantial Corrosion do require additional survey and examination in accordance with additional requirements found in ABS Rules. Areas of Substantial Corrosion identified also have to be thickness measured at subsequent Annual and Intermediate Surveys.

Vessels built with reduced scantlings may have “as built” thickness which falls into the Substantial Corrosion range (i.e., wastage in excess of 75% of the wastage allowance applied to the ABS Rule required thickness). In these cases, the additional survey and thickness measurement requirements required for areas of Substantial Corrosion would not be applied until such time as the protective coating in way of that area deteriorates to “FAIR” condition, as defined by the Rules.

Refer to 7-A-4/Figure 1, 7-A-4/Figure 2 and the applicable ABS Rules for specific requirements.

19 Suspect Areas

Suspect Areas are areas prone to rapid wastage or having Substantial Corrosion. Special attention should be paid to unprotected salt water ballast tanks, bilge wells, shaft alley recesses, pipe tunnels or duct keels, lower edges of bulkheads, bulkhead stools, overhead of cross deck structure on bulk carriers, exposed hatch covers, hatch coamings and brackets, areas just above joint of tween deck or tank top to side shell plating, horizontal stringers and webs, shell plating adjacent to transverse bulkhead boundary welds, void spaces under boilers, plating in way of steam drains and adjacent to heated tanks, plating in way of airports, areas where drainage accumulates or flows very fast, and panting areas. In tankers, the bottom area in the aftermost bay of cargo tanks is also a suspect area, particularly under suction bellmouths and where drainage velocity is high.

21 Thickness Measurements on Behalf of Underwriters

Since the late 1960’s, the American Hull Insurance Syndicate has imposed thickness measurement requirements on what they consider overage vessels. ABS has agreed to witness these thickness measurements if requested to do so by the Owner. The extent of the thickness measurements will be as requested by the Owner, however, should the Owner not issue any specific instructions, the Surveyor should be guided by the requirements for the upcoming Special Periodical Survey.

The thickness measurements taken should be dealt with as though taken for a Special Periodical Survey. They should be verified as representative; reviewed for individual plate wastages and average wastage of top and bottom areas; and wastage in excess of allowable limits dealt with. Any unrepaired wastage found should be noted in the same manner for Underwriters as required for Classification, but as a general rule, Underwriters will not accept deferred renewals or repairs.

23 Thickness Measurements Carried Out Afloat (2017)

Thickness measurements for vessels on the Continuous Survey System carried out afloat from inside may be accepted, provided they are accompanied by a diver’s report. The diver is to carefully examine and report on the bottom plating and welds, the rudder and the stern frame for damage, localized corrosion or pitting, as well as the other underwater body items required for the Underwater Inspection in Lieu of Drydocking.

Thickness measurements carried out afloat from outside may be accepted. The diver is to be qualified in underwater, ultrasonic thickness measurement and the procedure confirmed on-site, as required. In addition, the diver is to carefully examine and report on the bottom plating and welds, the rudder and the stern frame for damage, localized corrosion or pitting, as well as the other underwater body item requirements for the Underwater Inspections in lieu of Drydocking.

For those vessels which require Drydocking Survey as part of Intermediate Survey or Special Periodical Survey, thickness measurements carried out afloat for purpose of Intermediate Survey or Special Periodical Survey will require confirmatory thickness measurements at time of drydocking for that Intermediate Survey or Special Periodical Survey.

25 Installation and Inspection of Special Fixed Ballast Materials (2010)

25.1 General

25.1.1

The term fixed ballast covers various forms such as liquids (drilling mud, treated water, etc.), heavy solids (pig iron, steel plates, scrap iron, lead etc.) and concrete. In all cases, details of the permanent ballast as well as changes to the stability information and vessel's longitudinal strength are to be submitted for review as applicable to an ABS Engineering Office. Plans, calculations and procedures for approval of fixed ballast installations are to be submitted in one coordinated package. ABS approval of the package is to be obtained prior to installation of the ballast material.

25.1.2

The use of high density materials for fixed ballast installations may cause excessive structural loading on a vessel. Therefore, the following plans and calculations are to be submitted for approval:

- i) An arrangement plan showing proposed types, locations and quantities of fixed ballast.
- ii) A capacity plan showing the original capacity of each space in which fixed ballast will be installed.
- iii) A midship section plan and section modulus calculations, indicating maximum allowable bending moments and shear forces.
- iv) A longitudinal strength study which evaluates the proposed normal loading and ballasted conditions in conjunction with all fixed ballast.
- v) A structural evaluation of each fixed ballast compartment for the weight and location of the proposed ballast installation.

25.1.3

Special arrangements may be necessary to provide proper ventilation and to facilitate the installation and inspection of the ballast material. The following guidance applies to all fixed ballast installations:

- i) Each ballast tank is to be fitted with vents to the weather deck. Flame screens are to be installed if organic decay is possible.
- ii) Fixed ballast is not to be installed in tanks containing piping systems which require inspection. If fixed ballast must be installed in such tanks, a pipe tunnel or other suitable arrangement is to be made to permit inspection of the piping.
- iii) The ballast material is to be properly secured to prevent shifting in severe weather.
- iv) Inspection openings are to be provided in each corner of the ballast space for detection of shifting or settling of the material or seepage of water into the ballast space. Manholes may be provided for this purpose in double bottom tanks. If concrete caps are used to secure the ballast, ullage pipes at least 200 mm (8 in.) in diameter are to be fitted in the concrete to permit inspection of the ballast material.
- v) An expansion trunk is to be provided which is adequate for the maximum volumetric expansion of liquid ballast.
- vi) Plans showing ventilation of the fixed ballast space, the securing arrangement of the ballast material, and all closure plate installations for openings cut in the vessel structure are to be submitted for approval.

25.1.4

Fixed ballast is often installed in compartments or tanks which would normally be examined for deterioration during periodic inspections. The following procedures may be followed in lieu of emptying fixed ballast tanks each inspection period:

- i) The atmosphere in each tank is to be tested for safe entry.
- ii) All fixed ballast installations are to be accessed through the ullage openings provided. The ballast material is to be inspected for shifting, settling, and excessive moisture. Visible change to the ballast material may be cause for removal and additional inspection.
- iii) If a bacteriostatic agent is required, a sample of ballast fluid from the mid-depth of each tank is to be removed for analysis to determine the bacteriostatic agent residual and the presence of any methane gas or gas producing bacteria. If there is evidence that the bacteriostatic agent residual is inadequate to prevent bacteria growth, the fluid is to be pumped out and retreated with a bacteriostatic agent.
- iv) If installed, the tank material test pieces are to be examined to determine the apparent type and rate of corrosion. If there is indication that extensive or accelerated corrosion is taking place, the ballast material is to be pumped out and the tank cleaned for internal examination.

25.1.5

During new construction, tanks designated for fixed ballast are to be surveyed and tested in accordance with the rules for ballast tanks and approved drawings prior to the installation of the fixed ballast.

25.1.6

For existing vessels converting existing tanks to fixed ballast tanks, the following is applicable prior to the installation of fixed ballast:

- i) The tank is to be thoroughly examined internally and repaired as deemed necessary,
- ii) The structure (tank top, shell plating, internals, bulkheads, as applicable) are to be thoroughly gauged. All areas of excessive and substantial corrosion are to be repaired to the satisfaction of the attending Surveyor,
- iii) Tank to be proven tight,
- iv) Tanks are to be fitted with means of sounding and air pipe as applicable. All other piping systems should be blanked off unless the fixed ballast tank will also use salt water ballast.

25.1.7

All fixed ballast tanks or compartments are to be fitted with a corrosion test plate in way of each manhole cover. Test plates are to be of similar material as the internals in the tank. The thickness of the test plate should be 12.5 mm (0.5 in.) and be no smaller than 600 mm × 100 mm (24 in. × 4 in.). The corrosion test plate is to be prepared in the same manner as the tank structure. The test plate is to be connected to the underside of the manhole cover in such a manner that the plate hangs down to the mid-depth of the ballast tank. A corrosion test plate may be secured to a guide wire attached to the tank bottom. Test plates are to be marked by the attending Surveyor with port, report number, date, tank number, and Maltese Cross. A permanent record of the date of installation, weight, and thickness of each corrosion test plate should be kept aboard the vessel. After each inspection crew should record the thickness, weight and date of inspection in this record.

25.1.8

Survey reports should clearly identify the fixed ballast tanks or compartments, type of ballast material, density and/or quantity of ballast material fitted in each compartment as well as details of the corrosion test plate fitted. The vessel information module and status are to identify those tanks or compartments used for fixed ballast as well as the type of ballast used.

25.3 Fixed Liquid Ballast

25.3.1

Liquid ballast, including special drilling mud type fluids, may be used as fixed ballast, under the following provisions:

- i) *Bacteriostatic agent.* A bacteriostatic agent effective against aerobic as well as anaerobic bacteria is to be thoroughly mixed with the fluid in accordance with the manufacturer's specifications.
- ii) *Anticorrosivity.* The pH factor of the fluid is to be adjusted to a value which minimizes corrosion for the particular metals involved. Corrosion inhibitors may be added to the fluid, but they are not to interfere with the action of the bacteriostatic agent or affect the physical properties of the fluid such as suspension, viscosity, etc.
- iii) *Settling.* Fluids are to have sufficient viscosity and gel strength to minimize settling of solids.
- iv) *Thermal expansion.* Volumetric expansion is not to be greater than four tenths of one percent (0.4%) over a temperature range from -2.2°C (28°F) to 36.7°C (90°F). The fluid is to withstand an ambient low temperature of -2.2°C (28°F) without freezing. Unless adjacent to high temperature spaces, the expected maximum temperature of the ballast is to be taken as 36.7°C (90°F).
- v) *Proposed ballast.* A sample of proposed ballast fluid is to be prepared by the manufacturer and subjected to at least a thirty day test to demonstrate that all of the above requirements are fulfilled. A report of the test is to be made available to the Surveyor prior to installation of the fluid.
- vi) *Corrosion test plates.* The tank is to be fitted with an approved corrosion-test-plate as described in 7-A-4/25.1.7.
- vii) *Air pockets.* When pumping the fluid into the ballast tanks, care is to be taken to eliminate all air pockets. Permanently installed ship's pumps or piping are not to be used for handling the fluid.

25.3.2

The Surveyor may recommend that internal examination and thickness measurements of properly prepared, fixed liquid ballast tanks be waived provided:

- i) At each Special Periodical Survey, the corrosion test plate is examined and found free of substantial corrosion.
- ii) Where drilling mud is the ballast liquid, a chemical test of the atmosphere from the tank vent indicates no bacteriological action (evolution of methane gas).
- iii) A chemical test of the ballast fluid from mid-depth indicates that the inhibitors are still effective (This may be covered by continuous test records).
- iv) No leaks are found during test of the tank.

25.5 Fixed Ballast Using Solid Materials

25.5.1

Solid materials, including dry iron ore concentrate, may be used as fixed ballast under the following provisions:

- i) *Density.* The overall density of the material after installation is to equal the calculated density as submitted. Compaction is usually necessary to achieve the calculated density and to prevent later settling. Before capping, the actual weight of the ballast material is to be determined and recorded.

- ii) *Concrete caps.* Concrete caps are to be used to prevent shifting of ballast material in partially filled spaces. All excess water is to be removed before the concrete is poured. A moisture barrier, such as plastic sheeting, is to be installed on top of the ballast before pouring the concrete to prevent additional moisture from being added. Brackets are to be installed at the boundaries of the ballasted spaces so that the concrete will flow around them and provide anchoring points to prevent the caps from shifting.
- iii) *Corrosion test plates.* The tank is to be fitted with an approved corrosion-test-plate as described in 7-A-4/25.1.7.
- iv) The structure is to be blasted and coated prior to placing the ballast in the tank (as a minimum a primer coating must be present).
- v) Ballast material to be secured in an approved manner to prevent shifting in severe weather.

25.5.2

The Surveyor may recommend that internal examination and thickness measurements (internal structure) of properly prepared, fixed ballast tank or compartment be waived at each Intermediate and Special Survey provided:

- i) At each Intermediate and Special Periodical Survey, the corrosion test plate is examined and found free of substantial corrosion,
- ii) No evidence of leaks are found,
- iii) The ballast material to be visually inspected for shifting or settling and excessive moisture. Visible changes to the ballast material may be cause for removal and additional inspection.
- iv) Gaugings are to be taken in a five (5) point pattern over each plate in way of the tank top, bottom plating and other accessible areas in way of the fixed ballast tank or compartment and are to be carried out during each drydocking survey associated with the Special Survey. If any indication of substantial corrosion is found then additional gaugings are to be taken in accordance with Rule requirements contained in 7-3-2/7.

25.5.3

Solid Materials slurry may be installed in ballast compartments under the following provisions:

- i) *Slurry contents.* A list of ingredients of the slurry is to be submitted for approval. The list is to include a brief description of each ingredient and its weight and volume per slurry unit. Wet and dry weight and pH range for the complete slurry mixture are to be calculated.
- ii) *Cutouts.* Numerous openings in the ballast tank top may be necessary to facilitate the slurry flowing between each frame. However, sufficient strength must be maintained in structural tank tops. A plan showing the location and size of each cutout and the welding procedure to replace them is to be submitted.
- iii) *Air pockets.* Shifting will occur unless all air pockets within the ballast compartment have been filled. After dewatering is completed, the ullage below the tank top is not to exceed three inches at any point. An inspection for shifting ballast material is to be made following the first several voyages if air pocketing is suspected.
- iv) *Moisture.* The percentage volume of moisture entrained in the ballast after installation is not to be greater than seven percent over a temperature range from 2.2°C (28°F) to 32.2°C (90°F).
- v) *Corrosion test plates.* The tank is to be fitted with an approved corrosion-test-plate as described in the 7-A-4/25.1.7.

25.5.4

The Surveyor may recommend that internal examination and thickness measurements of properly prepared, fixed, solid materials slurry ballast tanks be waived provided:

- i) At each Special Periodical Survey the corrosion test plate is examined and found free of substantial corrosion.
- ii) Where drilling mud is the ballast liquid, a chemical test of the atmosphere from the tank vent indicates no bacteriological action (evolution of methane gas).
- iii) A chemical test of the ballast fluid from mid-depth indicates that the inhibitors are still effective (This may be covered by continuous test records).
- iv) No leaks are found during test of the tank.

25.7 Fixed Ballast Using Concrete

25.7.1

Tanks or compartments used for fixed ballast using materials such as concrete are to be prepared as follows:

- i) *Ballast material contents.* A list of ingredients of the ballast material should be submitted for approval. The list should include a brief description of each ingredient and its weight and volume per slurry unit. Wet and dry weight and pH range for the complete slurry mixture should be calculated.
- ii) *Cutouts.* Numerous openings in the ballast tank top may be necessary to facilitate the ballast material flowing between each frame. However, sufficient strength must be maintained in structural tank tops. A plan showing the location and size of each cutout and the welding procedure to replace them is to be submitted.
- iii) *Corrosion test plates.* The tank is to be fitted with an approved corrosion-test-plate as described in the 7-A-4/25.1.
- iv) The structure is to be blasted and coated prior to placing the ballast in the tank (as a minimum a primer coating must be present).
- v) Ballast material to be secured in an approved manner to prevent shifting in severe weather.

25.7.2

The Surveyor may recommend that internal examination and thickness measurements (internal structure) of properly prepared, permanent ballast tanks be waived at each Intermediate and Special Surveys provided:

- i) At each Intermediate and Special Periodical Surveys the corrosion test plate is examined and found free of substantial corrosion,
- ii) No evidence of leaks are found (note: if arrangement is such that the tank also uses ballast water in addition to the permanent ballast then tank to be tested),
- iii) The ballast material to be visually inspected for shifting or settling and excessive moisture. Visible changes to the ballast material may be cause for removal and additional inspection,
- iv) Gaugings are to be taken in a five (5) point pattern over each plate in way of the tank top, bottom plating and other accessible areas in way of the fixed ballast tank or compartment and are to be carried out during each drydocking survey associated with the Special Survey. If any indication of substantial corrosion is found then additional gaugings are to be taken in accordance with Rule requirements contained in 7-3-2/7.

27 Individual Plate Wastage Allowances

The wastage allowances for individual plates are found in 7-A-4/Table 1, 7-A-4/Table 2 and 7-A-4/Table 3.

Guidance wastage allowances for rudders or rudder components are:

- Rudder side plating and vertical diaphragms: 25%
- Rudder top and bottom plating and horizontal diaphragms: 30%

29 Wastage Compensation and Repair

Wasted areas are to be repaired to the satisfaction of the Surveyor or noted as outstanding recommendations in the survey report.

Individual plates or structural members which are wasted in excess of allowable limits are to be cropped and renewed. The primary concerns in assessing overall wastage are the hull longitudinal strength and the local buckling strength.

Localized wastage and pitting is to be dealt with to the satisfaction of the Surveyor and may not require renewal. Local wastage should be viewed from the standpoint of local buckling, fracture and the potentially serious risk of marine pollution. Localized areas of serious wastage, pitting or grooving may have to be dealt with immediately.

Highly localized pitting, usually found in cargo oil tanks, may be cropped and renewed, cleaned and coated with a special coating, cleaned and filled with a special filler, or repaired by welding. The choice of repair method depends mainly on the percentage of the plating surface area which is pitted, the depth of pits and the size of pits. The Surveyor will make the appropriate repair recommendation considering the particular circumstances. IACS "Shipbuilding and Repair Quality Standard" and Tanker Structure Co-operative Forum "Guidance Manual for Tanker Structures" may be referred to for additional information on pitting repairs.

Areas showing signs of load deformation (permanent set) or stress corrosion may have to be reinforced or renewed even though the wastage allowance may not have been exceeded.

Partial renewal of a plate is permitted provided the remaining portion is satisfactory. Small inserts should be avoided because fractures frequently develop, probably due to cumulative shrink stress and notch effect at the corners. Preferred renewal is full width, and length no less than the width; or at least half-width and length equal to one plate width or more. For less than full width inserts, the corner that does not land on a seam or butt should be radiused. For local inserts, the minor dimension should never be less than 300 mm (12 in.).

Replacement plating should be the same, equivalent or higher Grade and substantially the same thickness as the original Rule requirement. Replacement shapes must equal original Rule section modulus (with plate) and sectional area. Substitutions of steel differing from that originally installed, alteration of original structural configuration or change from riveted to welded joints is not to be made without prior approval from an ABS Technical Office.

Local doublers are not acceptable as a permanent repair or wastage compensation. If such doublers are found, the plating underneath should be carefully investigated and repaired, where found necessary.

Where straps are resorted to for area loss compensation of deck or bottom plating area, there must be sufficient material underneath to effectively transmit the load. If used to reinforce a longitudinal strength member, then continuity must be maintained throughout the affected area. Any local plate wastage is to be dealt with by renewal prior to the installation of straps.

In general, a strap should be continuous throughout the amidships 0.5L and no more than 1.5 times the thickness of the underlying plating. The strap should fit tightly onto the underlying plating and be continuously welded around the edges; if over 600 mm (24 in.) wide, it should also be plug-welded on 300 mm (12 in.) centers. Strap ends should taper in width and terminate at least two frame spaces or approximately 2 meters (6 ft.) beyond structural changes-in-section (such as hatch ends or superstructure end bulkheads). Where possible, straps should be situated over underdeck longitudinal girders or bulkheads. All proposals for continuous strapping are subject to approval by an ABS Technical Office.

In any case where elimination of riveted joints or change of structural form is contemplated in connection with renewals, prior approval must be obtained from an ABS Technical Office.

31 Wastage Rates – Effects on Thinner Members and Welds

In assessing the overall condition, it must be understood that where wastage limits are based on a percentage, thinner members will reach the limit sooner, assuming that material loss rate per surface is the same. Also, where both surfaces of a member are exposed to the same wastage conditions, the limit will be approached at double the normal rate. For instance, internals in most ballast tanks, since they are exposed to corrosion on both surfaces and because they are often originally thinner than the plating in the same area, usually reach the limiting wastage much earlier than the plating.

Special attention should be paid to the fillet welds attaching internals to the plating, particularly in forepeak tanks and on the underdeck of tankers. The wastage of the heavy deck longitudinals may be relatively low on a percentage basis, but the relatively small fillet welding attaching the longitudinals to the plating may be already wasted sufficiently so as to render the internal member ineffective. Likewise, internal members such as hold frames and end brackets on bulk carriers may be subject to necking and grooving corrosion adjacent to connection which will require special attention and thickness measurements.

33 Criteria for Longitudinal Strength of Hull Girder for Oil Tankers

33.1 General

33.1.1 (1 July 2005)

These criteria are to be used for the evaluation of longitudinal strength of the ship's hull girder as required by 7-3-2/15.1.2.

33.1.2

In order that the ship's longitudinal strength to be evaluated can be recognized as valid, fillet welding between longitudinal internal members and hull envelopes is to be in sound condition so as to keep integrity of longitudinal internal members with hull envelopes.

33.3 Evaluation of Longitudinal Strength (1 July 2006)

On oil tankers of 130 m in length and above and of over 10 years of age, the longitudinal strength of the ship's hull girder is to be evaluated in compliance with the requirements of this Appendix on the basis of the thickness measured, renewed or reinforced, as appropriate, during the special survey.

The condition of the hull girder for longitudinal strength evaluation is to be determined in accordance with the methods specified in 7-A-4/33.3.5.

33.3.1 Calculation of Transverse Sectional Areas of Deck and Bottom Flanges of Hull Girder

33.3.1(a) The transverse sectional areas of deck flange (deck plating and deck longitudinals) and bottom flange (bottom shell plating and bottom longitudinals) of the ship's hull girder are to be calculated by using the thickness measured, renewed or reinforced, as appropriate, during the special survey.

33.3.1(b) If the diminution of sectional areas of either deck or bottom flange exceeds 10 % of their respective as-built area (i.e. original sectional area when the ship was built), either one of the following measures is to be taken:

- i) Renew or reinforce the deck or bottom flanges so that the actual sectional area is not less than 90% of the as-built area; or
- ii) Calculate the actual section modulus (Z_{act}) of the transverse section of the ship's hull girder by applying the calculation method specified in 7-A-4/33.3.3, by using the thickness measured, renewed or reinforced, as appropriate, during the special survey.

33.3.2 Requirements for Transverse Section Modulus of Hull Girder

33.3.2(a) The actual section modulus of the transverse section of the ship's hull girder calculated in accordance with the foregoing 7-A-4/33.3.1(b)ii) is to satisfy either of the following provisions, as applicable:

- i) For ships constructed on or after 1 July 2002, the actual section modulus (Z_{act}) of the transverse section of the ship's hull girder calculated in accordance with the requirements of the foregoing 7-A-4/33.3.1(b)ii) is not to be less than the diminution limits determined by ABS*; or
- ii) For ships constructed before 1 July 2002, the actual section modulus (Z_{act}) of the transverse section of the ship's hull girder calculated in accordance with the requirements of the foregoing 7-A-4/33.3.1(b)ii) is to meet the criteria for minimum section modulus for ships in service required by ABS, provided that in no case Z_{act} is to be less than the diminution limit of the minimum section modulus (Z_{mc}) as specified in 7-A-4/33.3.4.

Notes:

* The actual transverse section modulus of the hull girder of oil tankers calculated under paragraph 2.2.1.1 of Annex III to UR Z10.1 or UR Z10.4, as applicable, is not to be less than 90% of the required section modulus for new buildings specified in IACS Unified Requirements S7** or S11, whichever is the greater.

** $C = 1.0c_n$ is to be used for the purpose of this calculation.

33.3.3 Calculation Criteria of Section Modulus of Midship Section of Hull Girder

- 1 When calculating the transverse section modulus of the ship's hull girder, the sectional area of all continuous longitudinal strength members is to be taken into account.
- 2 Large openings, i.e., openings exceeding 2.5 m in length or 1.2 m in breadth and scallops, where scallop welding is applied, are always to be deducted from the sectional areas used in the section modulus calculation.
- 3 Smaller openings (manholes, lightening holes, single scallops in way of seams, etc.) need not be deducted provided that the sum of their breadths or shadow area breadths in one transverse section does not reduce the section modulus at deck or bottom by more than 3% and provided that the height of lightening holes, draining holes and single scallops in longitudinals or longitudinal girders does not exceed 25% of the web depth, for scallops maximum 75 mm.
- 4 A deduction-free sum of smaller opening breadths in one transverse section in the bottom or deck area of $0.06(B - \sum b)$ (where B = breadth of ship, $\sum b$ = total breadth of large openings) may be considered equivalent to the above reduction in section modulus.
- 5 The shadow area is obtained by drawing two tangent lines with an opening angle of 30°.
- 6 The deck modulus is related to the molded deck line at side.
- 7 The bottom modulus is related to the base line.
- 8 Continuous trunks and longitudinal hatch coamings are to be included in the longitudinal sectional area provided they are effectively supported by longitudinal bulkheads or deep girders. The deck modulus is then to be calculated by dividing the moment of inertia by the following distance, provided this is greater than the distance to the deck line at side:

$$y_t = y \left(0.9 + 0.2 \frac{x}{B} \right)$$

where

- y = distance from neutral axis to top of continuous strength member
- x = distance from top of continuous strength member to centerline of the ship

x and y to be measured to the point giving the largest value of y_t .

- 9 Longitudinal girders between multi-hatchways will be considered by special calculations.

33.3.4 Diminution Limit of Minimum Longitudinal Strength of Ships in Service

33.3.4(a) The diminution limit of the minimum section modulus (Z_{mc}) of oil tankers in service is given by the following formula:

$$Z_{mc} = cL^2B(C_b + 0.7)k \text{ cm}^3$$

where

L = length of ship. L is the distance, in meters, on the summer load waterline from the fore side of stem to the after side of the rudder post, or the center of the rudder stock if there is no rudder post. L is not to be less than 96%, and need not be greater than 97%, of the extreme length on the summer load waterline. In ships with unusual stern and bow arrangement the length L may be specially considered.

B = greatest molded breadth, in meters

C_b = molded block coefficient at draft d corresponding to summer load waterline, based on L and B . C_b is not to be taken less than 0.60.

$$= \frac{\text{molded displacement (m}^3\text{) at draft } d}{L B d}$$

c = $0.9c_n$

$$c_n = 10.75 - \left(\frac{L - 300}{100} \right)^{1.5} \quad \text{for } 130 \text{ m} \leq L \leq 300 \text{ m}$$

$$= 10.75 \quad \text{for } 300 \text{ m} < L < 350 \text{ m}$$

$$= 10.75 - \left(\frac{L - 350}{150} \right)^{1.5} \quad \text{for } 350 \text{ m} \leq L \leq 500 \text{ m}$$

k = material factor, e.g.

= 1.0 for mild steel with yield stress of 235 N/mm² and over

= 0.78 for high tensile steel with yield stress of 315 N/mm² and over

= 0.72 for high tensile steel with yield stress of 355 N/mm² and over

33.3.4(b) Scantlings of all continuous longitudinal members of the ship's hull girder based on the section modulus requirement in 7-A-4/33.3.4(a) above are to be maintained within 0.4L amidships. However, in special cases, based on consideration of type of ship, hull form and loading conditions, the scantlings may be gradually reduced towards the end of 0.4L part, bearing in mind the desire not to inhibit the ship's loading flexibility.

33.3.4(c) However, the above standard may not be applicable to ships of unusual type or design, e.g., for unusual main proportions and/or weight distributions.

33.3.5 Sampling Method of Thickness Measurements for Longitudinal Strength Evaluation and Repair Methods (1 July 2005)

33.3.5(a) *Extent of longitudinal strength evaluation.* Longitudinal strength should be evaluated within 0.4L amidships for the extent of the hull girder length that contains tanks therein and within 0.5L amidships for adjacent tanks which may extend beyond 0.4L amidships, where tanks means ballast tanks and cargo tanks.

33.3.5(b) Sampling method of thickness measurement.

- i)* Pursuant to the requirements of 7-3-2/5.1.9 and 7-3-2/5.13.5 or 7-3-2/5.14.5, as applicable, transverse sections should be chosen such that thickness measurements can be taken for as many different tanks in corrosive environments as possible, e.g. ballast tanks sharing a common plane boundary with cargo tanks fitted with heating coils, other ballast tanks, cargo tanks permitted to be filled with seawater and other cargo tanks. Ballast tanks sharing a common plane boundary with cargo tanks fitted with heating coils and cargo tanks permitted to be filled with seawater should be selected where present.
- ii)* The minimum number of transverse sections to be sampled should be in accordance with 7-3-2/5.13.5 or 7-3-2/5.14.5, as applicable. The transverse sections should be located where the largest thickness reductions are suspected to occur or are revealed from deck and bottom plating measurements prescribed in 7-A-4/33.3.5(b)iii) and should be clear of areas which have been locally renewed or reinforced.
- iii)* At least two points should be measured on each deck plate and/or bottom shell plate required to be measured within the cargo area in accordance with the requirements of 7-3-2/5.13.5 or 7-3-2/5.14.5, as applicable.
- iv)* Within $0.1D$ (where D is the vessel's molded depth) of the deck and bottom at each transverse section to be measured in accordance with the requirements of 7-3-2/5.13.5 or 7-3-2/5.14.5, as applicable, every longitudinal and girder should be measured on the web and face plate and every plate should be measured at one point between longitudinals.
- v)* For longitudinal members other than those specified in 7-A-4/33.3.5(b)iv) to be measured at each transverse section in accordance with the requirements of 7-3-2/5.13.5 or 7-3-2/5.14.5, as applicable, every longitudinal and girder should be measured on the web and face plate and every plate should be measured at least in one point per strake.
- vi)* The thickness of each component should be determined by averaging all of the measurements taken in way of the transverse section on each component.

33.3.5(c) Additional measurements where the longitudinal strength is deficient.

- i)* Where one or more of the transverse sections are found to be deficient in respect of the longitudinal strength requirements given in this Appendix, the number of transverse sections for thickness measurement should be increased such that each tank within the $0.5L$ amidships region has been sampled. Tank spaces that are partially within, but extend beyond, the $0.5L$ region, should be sampled.
- ii)* Additional thickness measurements should also be performed on one transverse section forward and one aft of each repaired area to the extent necessary to verify that the areas bordering the repaired section also comply with the requirements of this Appendix and 7-3-2/5.13.5 or 7-3-2/5.14.5, as applicable.

33.3.5(d) Effective repair methods.

- i)* The extent of renewal or reinforcement carried out to comply with this Appendix should be in accordance with 7-A-4/33.3.5(d)ii).
- ii)* The minimum continuous length of a renewed or reinforced structural member should be not less than twice the spacing of the primary members in way. In addition, the thickness diminution in way of the butt joint of each joining member forward and aft of the replaced member (plates, stiffeners, girder webs and flanges, etc.) should not be within the substantial corrosion range (75% of the allowable diminution associated with each particular member). Where differences in thickness at the butt joint exceed 15% of the lower thickness, a transition taper should be provided.

- iii) Alternative repair methods involving the fitting of straps or structural member modification are subject to special consideration. Fitting of straps, should be limited to the following conditions:
 - a. To restore and/or increase longitudinal strength;
 - b. The thickness diminution of the deck or bottom plating to be reinforced should not be within the substantial corrosion range (75% of the allowable diminution associated with the deck plating);
 - c. The alignment and arrangement, including the termination of the straps, is in accordance with a standard approved by an ABS Technical Office;
 - d. The straps are continuous over the entire $0.5L$ amidships length; and
 - e. Continuous fillet welding and full penetration welds are to be used at butt welding and, depending on the width of the strap, slot welds are to be used. The welding procedures applied are to be acceptable to the ABS Technical Office and attending Surveyor.
- iv) The existing structure adjacent to replacement areas and in conjunction with the fitted straps, etc., is to be capable of withstanding the applied loads, taking into account the buckling resistance and the condition of welds between the longitudinal members and hull envelope plating.

35 Thickness Measurements Carried Out on IACS Common Structural Rules (CSR) Vessels (1 July 2013)

35.1 Bulk Carriers (Single Skin and Double Skin)

This section only applies to vessels built under the IACS Common Structural Rules for Bulk Carriers and Oil Tankers (CSR).

35.1.1 Number of Measurements

Considering the extent of thickness measurements according to the different structural elements of the ship and surveys (special, intermediate and annual), the locations of the points to be measured are given for the most important items of the structure.

35.1.2 Locations of Measurements

7-A-6/Table 1 or 7-A-15/Table 1 provides explanations and/or interpretations for the application of those requirements indicated in the Rules, which refer to both systematic thickness measurements related to the calculation of global hull girder strength and specific measurements connected to close-up surveys.

7-A-6/Figures 7 to 10 or 7-A-15/Figures 7 to 12 are provided to facilitate the explanations and/or interpretations given in 7-A-15/Table 1, to show typical arrangements of single skin or double skin bulk carriers, respectively.

35.1.3 Acceptance Criteria

For vessels built under the IACS Common Structural Rules for Bulk Carriers and Oil Tankers, the Acceptance Criteria is according to Part 5A, Pt 1, Ch. 13 of CSR and as specified below in 7-A-4/35.1.3(a), (b) and (c).

35.1.3(a) Acceptance Criteria for Pitting Corrosion

- i) *Side Structures.* If pitting intensity in an area where coating is required, according to Part 5B, Pt 2, Sec 2, [2] of CSR, is higher than 15% (see 7-A-4/Figure 5), thickness measurements are to be performed to check the extent of pitting corrosion. The 15% is based on pitting or grooving on only one side of a plate.

In cases where pitting is exceeding 15%, as defined above, an area of 300 mm or more, at the most pitted part of the plate, is to be cleaned to bare metal and the thickness is to be measured in way of the five deepest pits within the cleaned area. The least thickness measured in way of any of these pits is to be taken as the thickness to be recorded.

The minimum remaining thickness in pits, grooves or other local areas is to be greater than the following without being greater than the renewal thickness (t_{ren}):

- 75% of the as-built thickness, in the frame and end brackets webs and flanges*
- 70% of the as-built thickness, in the side shell, hopper tank and topside tank plating attached to the each side frame, over a width up to 30 mm from each side of it.

* Note: Does not apply to double skin bulk carriers

- ii) *Other Structures.* For plates with pitting intensity less than 20%, see 7-A-4/Figure 5, the measured thickness, t_m of any individual measurement is to meet the lesser of the following criteria:

$$t_m \geq 0.7 (t_{as-built} - t_{vol add}) \text{ mm}$$

$$t_m \geq t_{ren} - 1 \text{ mm}$$

where

$t_{as-built}$ = as-built thickness of the member, in mm

$t_{vol add}$ = voluntary thickness addition; thickness, in mm, voluntarily added as the Owner's extra margin for corrosion wastage in addition to t_c

t_{ren} = renewal thickness; minimum allowable thickness, in mm, below which renewal of structural members is to be carried out

t_c = total corrosion addition, in mm, defined in Part 5A, Pt 1, Ch 3, Sec 3 of CSR

t_m = measured thickness, in mm, on one item (i.e., average thickness on one item using the various measurements taken on this same item during periodical ship's in service surveys)

The average thickness across any cross section in the plating is not to be less than the renewal criteria for general corrosion given in Part 5A, Pt 1, Ch 13 of CSR.

35.1.3(b) Acceptance Criteria for Edge Corrosion of CSR Ships

- i) Provided that the overall corroded height of the edge corrosion of the flange, or web in the case of flat bar stiffeners, is less than 25%, see 7-A-4/Figure 3, of the stiffener flange breadth or web height, as applicable, the measured thickness, t_m , is to meet the lesser of the following criteria:

$$t_m \geq 0.7 (t_{as-built} - t_{vol add}) \text{ mm}$$

$$t_m \geq t_{ren} - 1 \text{ mm}$$

- ii) The average measured thickness across the breadth or height of the stiffener is not to be less than that defined in Part 5A, Pt 1, Ch 13 of CSR.

- iii) Plate edges at openings for manholes, lightening holes etc. may be below the minimum thickness given in Part 5A, Pt 1, Ch 13 of CSR provided that:

- The maximum extent of the reduced plate thickness, below the minimum given in Part 5A, Pt 1, Ch 13 of CSR, from the opening edge is not more than 20% of the smallest dimension of the opening and does not exceed 100 mm.
- Rough or uneven edges may be cropped-back provided that the maximum dimension of the opening is not increased by more than 10% and the remaining thickness of the new edge is not less than $t_{ren} - 1$ mm.

35.1.3(c) *Acceptance Criteria for Grooving Corrosion of CSR Ships*

- i) Where the groove breadth is a maximum of 15% of the web height, but not more than 30 mm, see 7-A-4/Figure 4, the measured thickness, t_m , in the grooved area is to meet the lesser of the following criteria:

$$t_m \geq 0.75 (t_{as-built} - t_{vol add}) \text{ mm}$$

$$t_m \geq t_{ren} - 0.5 \text{ mm}$$

but is not to be less than $t_m = 6 \text{ mm}$

- ii) Structural members with areas of grooving greater than those in i) above are to be assessed based on the criteria for general corrosion as defined in Part 5A, Pt 1, Ch 13 of CSR using the average measured thickness across the plating/stiffener.

35.3 Double Hull Oil Tankers

This section only applies to vessels built under the IACS Common Structural Rules for Bulk Carriers and Oil Tankers (CSR).

35.3.1 Number of Measurements

Considering the extent of thickness measurements according to the different structural elements of the ship and surveys (special, intermediate and annual), the locations of the points to be measured are given for the most important items of the structure.

35.3.2 Locations of Measurements

7-A-13/Table 1 provides explanations and/or interpretations for the application of those requirements indicated in the Rules, which refer to both the systematic thickness measurements related to the calculation of the global hull girder strength and specific measurements connected to close-up surveys.

7-A-13/Figures 6 to 9 are provided to facilitate the explanations and/or interpretations given in 7-A-4/Table 1, to show typical arrangements of double hull oil tankers.

35.3.3 Acceptance Criteria

For vessels built under the IACS Common Structural Rules for Bulk Carriers and Oil Tankers, the Acceptance Criteria is according to Part 5A, Pt 1, Ch 13 of CSR and as specified below in 7-A-4/35.3.3(a), (b) and (c).

35.3.3(a) *Acceptance Criteria for Pitting Corrosion*

- i) For plates with pitting intensity less than 20%, see 7-A-4/Figure 5, the measured thickness, t_m , of any individual measurement is to meet the lesser of the following criteria:

$$t_m \geq 0.7 (t_{as-built} - t_{vol add}) \text{ mm}$$

$$t_m \geq t_{ren} - 1 \text{ mm}$$

where

$t_{as-built}$ = as-built thickness of the member, in mm

$t_{vol add}$ = voluntary thickness addition; thickness, in mm, voluntarily added as the Owner's extra margin for corrosion wastage in addition to t_c

t_{ren} = renewal criteria for general corrosion as defined in Part 5A, Pt 1, Ch 13, Sec 2, [2.1.1] of CSR

- ii) The average thickness across any cross section in the plating is not to be less than the renewal criteria for general corrosion given in Part 5A, Pt 1, Ch 13, Sec 2, [2] of CSR.

35.3.3(b) Acceptance Criteria for Edge Corrosion of CSR Ships

- i) Provided that the overall corroded height of the edge corrosion of the flange, or web in the case of flat bar stiffeners, is less than 25%, see 7-A-4/Figure 3, of the stiffener flange breadth of web height, as applicable, the measured thickness, t_m , is to meet the lesser of the following criteria:

$$t_m \geq 0.7 (t_{as-built} - t_{vol add}) \text{ mm}$$

$$t_m \geq t_{ren} - 1 \text{ mm}$$

where

$t_{as-built}$ = as-built thickness of the member, in mm

$t_{vol add}$ = voluntary thickness addition; thickness, in mm, voluntarily added as the Owner's extra margin for corrosion wastage in addition to t_c

t_{ren} = renewal criteria for general corrosion as defined in Part 5A, Pt 1, Ch 13, Sec 2, [2.1.1] of CSR

- ii) The average measured thickness across the breadth or height of the stiffener is not to be less than that defined in Part 5A, Pt 1, Ch 13, Sec 2, [2] of CSR.
- iii) Plate edges at openings for manholes, lightening holes etc. may be below the minimum thickness given in Part 5A, Pt 1, Ch 13, Sec 2, [2] of CSR provided that:
- The maximum extent of the reduced plate thickness, below the minimum given in Part 5A, Pt 1, Ch 13, Sec 2, [2] of CSR, from the opening edge is not more than 20% of the smallest dimension of the opening and does not exceed 100 mm.
 - Rough or uneven edges may be cropped-back provided that the maximum dimension of the opening is not increased by more than 10% and the remaining thickness of the new edge is not less than $t_{ren} - 1$ mm.

35.3.3(c) Acceptance Criteria for Grooving Corrosion

- i) Where the groove breadth is a maximum of 15% of the web height, but not more than 30 mm, see 7-A-4/Figure 4, the measured thickness, t_m , in the grooved area is to meet the lesser of the following criteria:

$$t_m \geq 0.75 (t_{as-built} - t_{vol add}) \text{ mm}$$

$$t_m \geq t_{ren} - 0.5 \text{ mm}$$

but is not to be less than $t_m = 6$ mm

where

$t_{as-built}$ = as-built thickness of the member, in mm

$t_{vol add}$ = voluntary thickness addition; thickness, in mm, voluntarily added as the Owner's extra margin for corrosion wastage in addition to t_c

t_{ren} = renewal criteria for general corrosion as defined in Part 5A, Pt 1, Ch 13, Sec 2, [2.1.1] of CSR

- ii) Structural members with areas of grooving greater than those in i) are to be assessed based on the criteria for general corrosion as defined in Part 5A, Pt 1, Ch 13, Sec 2, [2] of CSR using the average measured thickness across the plating/stiffener.

FIGURE 1
Typical Bottom Shell Thickness Measurement Patterns including Increased Pattern of Measurement in way of Substantial Corrosion

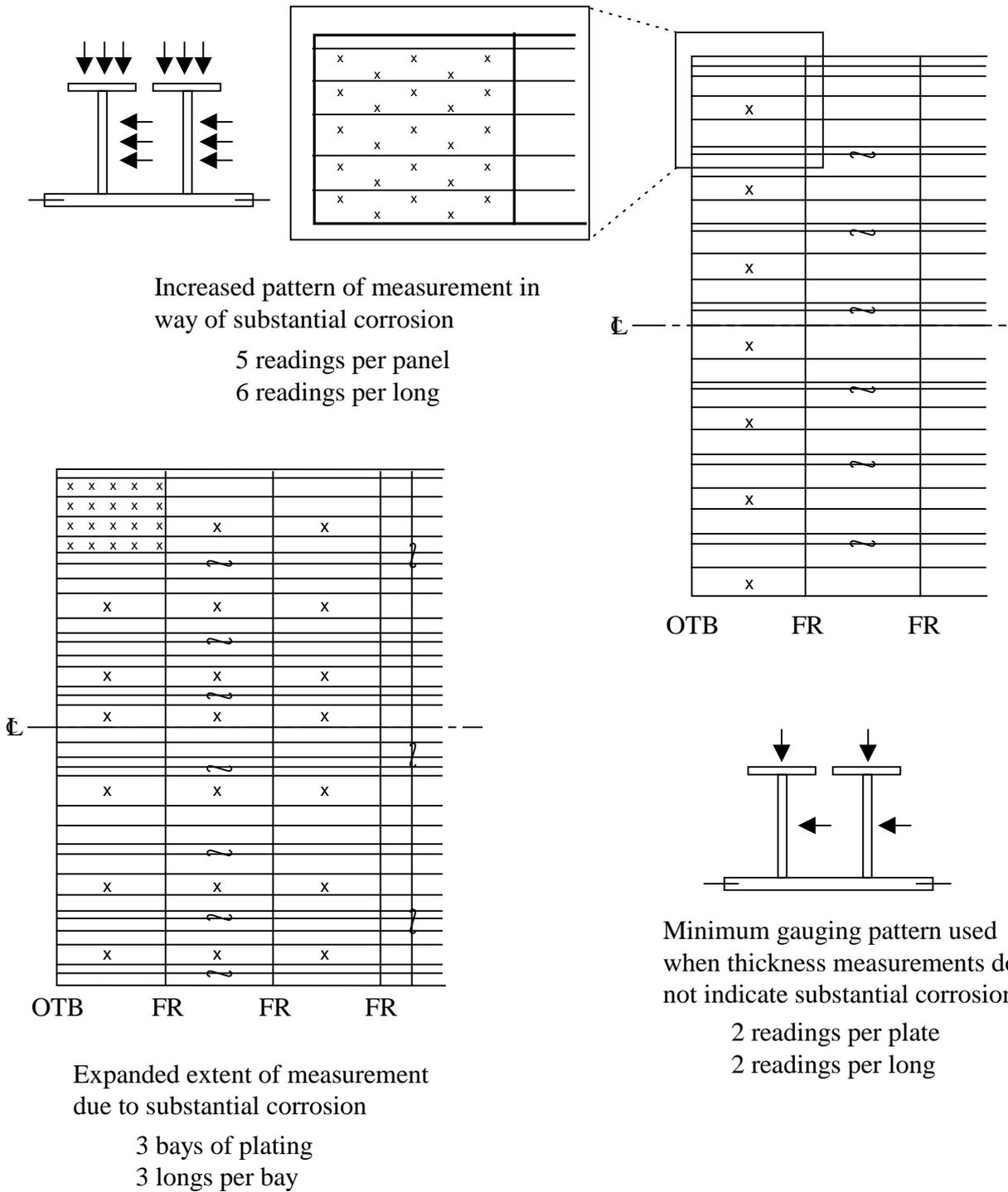

FIGURE 2

Example of Gauging Assessment – Individual Plate with Substantial Corrosion

- 1) In gauging a single bottom oil carrier during SSH #4, one transverse belt of the required three is laid out at Fr. 52. The bottom plates start in a ballast tank and extend forward into a cargo tank. Also, as vessel is undergoing SSH #4, all bottom plates within cargo length must be gauged.
- 2) For the one plate in this example, the original readings laid out by Surveyor are denoted with an asterisk. Two readings in transverse direction result in 0.77" and 0.87". Due to large variance, Surveyor asks for two more readings along the transverse section on the same plate and readings of 0.79" and 0.82" are obtained. From the four readings, a representative reading of 0.81" is recorded and is within allowable wastage limits for local plate wastage. However, since this is an oil carrier, the representative reading for the example plate at that transverse section is within the substantial corrosion range. The section of the plate at gauged transverse section Fr. 52 will require an increased pattern of measurement in accordance with Substantial Corrosion gauging tables and the extent of measurements must be extended from the gauged transverse section at Fr. 52 to the bottom structure in each panel of that bay, in accordance with 7-3-2/7.5.1(a) of the Rules.
- 3) For the one plate found with substantial corrosion, a five point pattern is taken on each panel of the plate within the suspect bay. Assessment of these gaugings indicates a corrosion pattern with representative condition of 0.78, which requires repair/renewal.
- 4) At the forward end of the plate, two readings are also taken as that end belongs to a tank of different service. See Note 4 to thickness measurement Table TM1-T of 7-A-7. Readings of 0.92" and 0.95" are obtained which are considered representative of the plate within the cargo tank and representative condition of 0.93" is recorded.
- 5) Please note that it is never correct to compare readings in a longitudinal direction or within spaces of different service when ascertaining representative conditions. Additionally, each area gauged must be examined for corrosion pattern with the additional, substantial corrosion assessment carried out where required by the individual corrosion patterns. For this example, comparing the forward and aft representative readings: 0.81" and 0.93" for a "representative" condition of 0.87", would misrepresent the actual condition of the portion of the plate within the ballast tank and would not have required the substantial corrosion assessment.

Minimum Rule Gaugings:

BALLAST TANK	CARGO TANK		
Fr. 53 - 52	Fr. 50		
* .77	* .95	Bottom Plate Original: 1.0" Substantial Corrosion: 0.85" Renewal: 0.80"	
.79			
* .87	* .92		
.82			

Representative: .81" Representative: .93"

Required increase on bottom plate pattern due to substantial corrosion:

Fr 53	Bay		Fr. 52	
.73	* .77	.75	.75	Panel
.74	.72	.75	* .79	.78 Panel
.77	.79	.82	* .87	.78 Panel
.76	* .82	.80	.81	.83 Panel

Representative of plate thickness between Fr. 52 – 53 = 0.78" ⇒ Repair/Renewal required

FIGURE 3
Example of Edge Corrosion (1 July 2013)

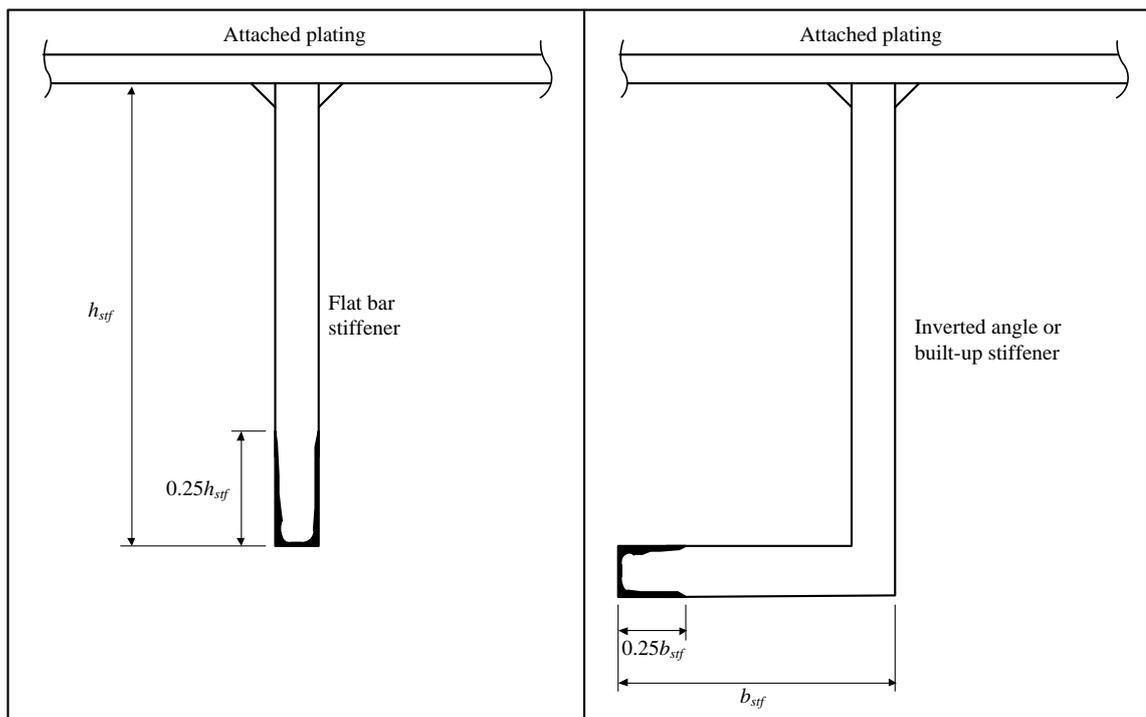

FIGURE 4
Example of Grooving Corrosion (1 July 2013)

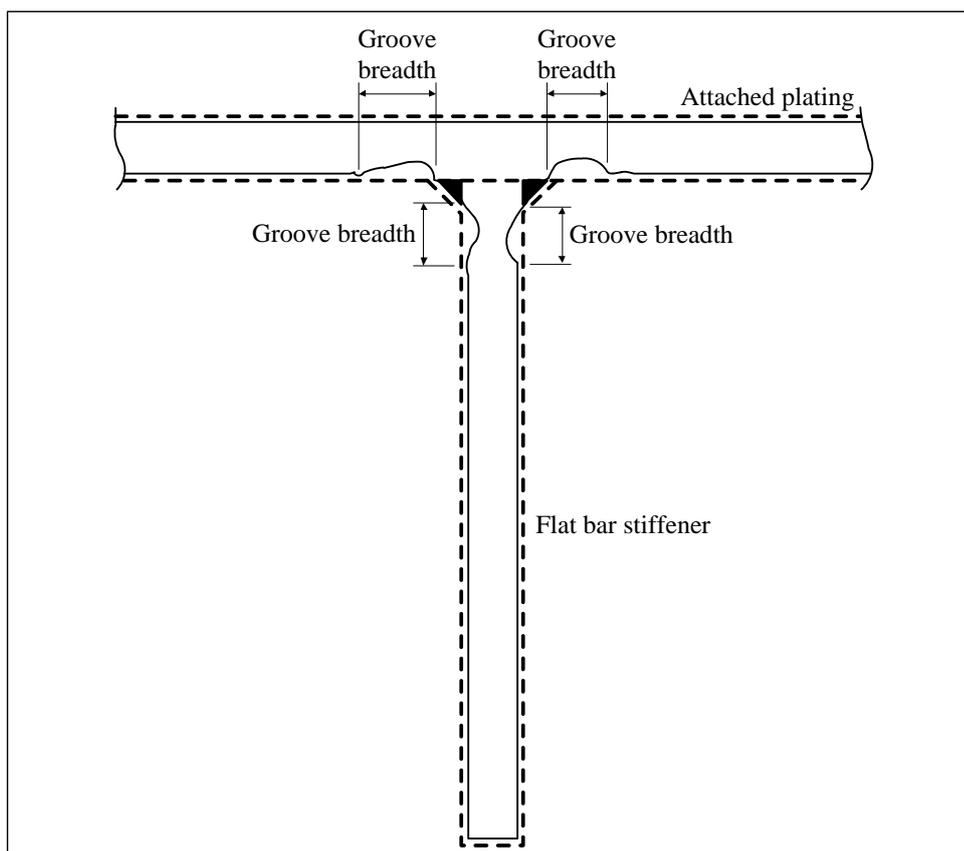

FIGURE 5
Pitting Intensity Diagrams (1 July 2013)

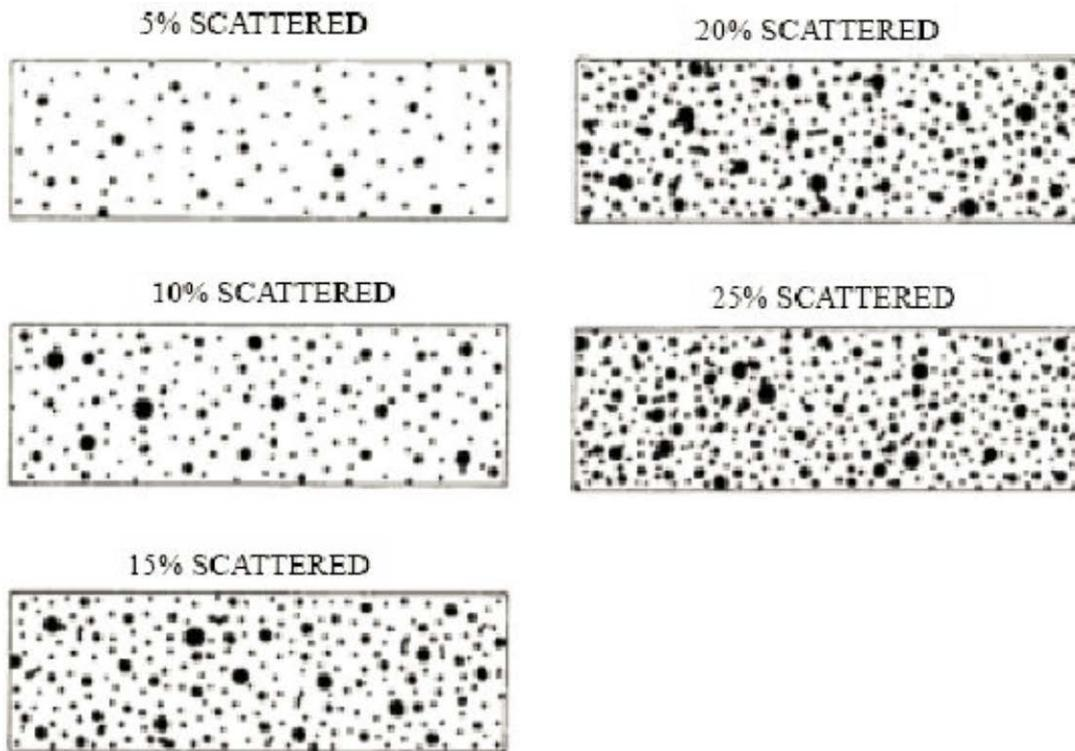

TABLE 1
Individual Wastage Allowances, Conventional Vessels 90 M and Over Built to ABS Class (2014)

(See Note 11, 12, 13 and 14)

Ordinary and High Strength Steel	BUILT 2005 OR LATER	BUILT BETWEEN 1962 AND 2005	BUILT 1962 OR LATER		Long'ly framed vessels built prior to 1962. Transv'ly framed vessels of all ages (See Note 9). Dry cargo barges 90 meters and over. Tank barges 90 to 122 meters (295-400 ft) (See Note 10).
	Double Bottom Tankers	Double Bottom Tankers	Single Bottom Tankers	Bulkers, OBOs, and Containerships	
Strength Deck Plating	20%	20%	20%	20%	25%
Continuous Long'l Hatch Coamings & Above Deck Box-Girders	20%	20%	-----	20%	25%
Deck Plates within Line of Hatches and at Ends.	30%	30%	30%	30%	30%
Forecastle, Poop and Bridge Deck Plates; Superstructure End Bulkheads	30%	30%	30%	30%	30%
(2008) Tween Deck Plates	-----	-----	-----	-----	30%
Sheer Strake Plates	20%	20%	20%	20%	25%
Side Shell Plates	20%	25%	25%	25%	25%
Bilge Strake Plates	20%	25%	20%	25%	25%
Bottom Plates	20%	25%	20%	25%	25%
Keel Plates (See Note 4)					
Outermost Strake of Inner Bottom (See Note 5)	20%	20%	-----	20%	30%
Other Plates of Inner Bottom (See Note 5)	20%	25%	-----	25%	30%
Top Strake of Longitudinal Bulkheads and Top Strake of Topside Tank Sloping Plating	20%	20%	20%	20%	25%
Bottom Strake of Longitudinal Bulkheads	20%	25%	20%	25%	25%
Other Plates of Longitudinal Bulkheads, Topside Tank Sloping Plating, Hopper Tank Sloping Plating and Transverse Bulkheads (See Notes 6 and 7)	20%	25%	25%	25%	25%
Internals including Longitudinals, Girders, Transverses, Struts, Bulkhead Webs and Stringers, Brackets and Hatch Side Girders	20%	25%	25%	25%	25%
Plates in way of Top of Tanks	25%	30%	30%	30%	30%
Underdeck Box Girders (Long'l or Transverse)	20%	20%	-----	20%	20%
Hatch Covers (See Note 8). Hatch coamings and brackets	30%	30%	30%	30%	30%

TABLE 1 (continued)
Individual Wastage Allowances, Conventional Vessels
90 M and Over Built to ABS Class (2014)

(See Note 11, 12, 13 and 14)

Notes:

- 1 Internals included in longitudinal strength must be continuous or be effectively developed at ends, throughout amidships 0.4L.
- 2 Structure must meet individual member thickness and average wastage.
- 3 If design was originally approved on basis of engineering analysis (such as car carriers and other specialized vessels), or if owner specially request, the wastage may be assessed on engineering basis (i.e., acceptable stress levels and structural stability).
- 4 Keel plates are to be renewed when they reach the minimum allowed thickness for adjacent bottom plating.
- 5 30% for bulk carriers and OBOs.
- 6 Bulk Carriers for which IACS UR S19 applies to the corrugated transverse watertight bulkhead between cargo holds 1 and 2 are to be assessed in accordance with S19 for initial compliance and subsequent continued compliance at each Intermediate Survey and Special Periodical Survey – Hull.
- 7 Bulk carriers for which UR S18 applies to the corrugated transverse W.T. bulkheads are to comply with the steel renewal provisions of S18.
- 8 The hatch covers of bulk carriers to which IACS UR S21 applies are to comply with the steel renewal provisions of S21.
- 9 Wastage allowances in column 4 (Bulkers, OBOs, etc.) apply to vessels with a combination of transverse and longitudinal framing.
- 10 Wastage allowances in columns 1, 2 or 3, depending on the barge's construction, apply to tank barges over 122 meters (400 ft.) in length.
- 11 The individual wastage allowances are acceptable, provided the SM is not less than 90% of the greater SM required: a) at the time of new construction or b) by 3-2-1/3.7.1(b).
- 12 For tankers 130 m in length and above and over 10 years of age, sectional area calculations are to be carried out by an ABS Technical Office.
- 13 For vessels built to other society rules, the Technical Office carrying out the initial plan review is to be contacted for wastage allowances.
- 14 (2014) For CSR vessels type, the individual wastage allowance is defined in accordance with Part 5A, Part 1 for double hull oil tankers and for bulk carriers.

TABLE 2
Individual Wastage Allowances, Conventional Vessels
Under 90 Meters (295 Feet) (2016)

Main Deck Plating	25%
Bottom Plating	25%
Keel Plating	25%
Sheer Strake	25%
Bilge Strake	25%
Side Shell Plating	30%
Forecastle	30%
Internals and Bulkheads	30%

For vessels built to other societies' rules, the Technical Office carrying out the initial plan review is to be contacted for wastage allowances.

Notes:

- 1 Internals included in longitudinal strength must be continuous or be effectively developed at ends, throughout amidships $0.4L$.
- 2 The values shown in the table are the minimum requirements for individual members and plates.
- 3 In addition to satisfying the individual member and plate requirements, it should be verified that the hull girder section modulus is not less than 90% of the greater Hull Girder Section Modulus required either:
 - a) At the time of new construction
 - b) Per 3-2-1/3.1 of the *ABS Rules for Building and Classing Steel Vessels Under 90 meters (295 feet) in Length*
- 4 For vessels less than 61 meters (200 feet) only, maximum loss of deck or bottom area is 20 percent of Rule required area.
- 5 For vessels built to other society rules, wastage allowance based on the previous society requirements may apply.

TABLE 3
Aluminum Wastage Allowances, Conventional Vessels
Under 90 M (295 Feet) built to ABS Class

Main Deck Plating	15%
Bottom Plating	15%
Keel Plating	15%
Sheer Strake	15%
Bilge Strake	15%
Side Shell Plating	20%
Forecastle	20%
Internals and Bulkheads	20%

For vessels built to other societies' rules, the Technical Office carrying out the initial plan review is to be contacted for wastage allowances.

TABLE 4
Wastage Allowances, Steel or Aluminum Yachts
24 m (79 ft) – 61 m (200 ft) in Length ⁽¹⁾

Longitudinally Framed Shell and Decks	15% ⁽²⁾
Transversely Framed Shell and Decks	10% ⁽³⁾
Other Internal Structure and External Structure Providing Weathertight Integrity to the Hull	15%

Notes:

- 1 Sometimes fairing filler is applied on the outside of the hull and deckhouse to cosmetically hide plating deformations. Ultrasonic measurement equipment may not be able to distinguish between the metal and the filler material. Prior to ultrasonic testing the Surveyor is to determine if fairing filler has been applied and by testing to determine if the ultrasonic equipment can distinguish between Fairing filler and base metal structure. If the Design Review Engineer has knowledge of fairing filler material being used it should be noted on the MTT Table to aid the Surveyor.
- 2 The permanent set of strength deck plating must be less than or equal to $s/100$, and no deformation of any frames, longitudinals or beams found, where s equals stiffener spacing. If deformation of the strength deck plating is greater than $s/100$, or if deformation of frames, longitudinals or beams is found, then contact a technical office for guidance.
- 3 The permanent set of strength deck plating must be less than or equal to $s/150$, and no deformation of any frames, longitudinals or beams found, where s equals frame spacing. If deformation of the strength deck plating is greater than $s/150$, or if deformation of frames, longitudinals or beams is found, then contact a technical office for guidance.
- 4 For vessels built to other societies' rules, the Technical Office carrying out the initial plan review is to be contacted for wastage allowances.

PART

7

APPENDIX

SECTION 5 Procedures for Certification of Firms Engaged in Thickness Measurement of Hull Structures

1 Application

This guidance applies for certification of the firms which intend to engage in the thickness measurement of hull structures of vessels.

(2008) This certification of the firms is not required for non-ESP/ESDC vessels under 90 meters in length, vessels in Great Lakes service or fishing vessels.

3 Procedures for Certification

3.1 Submission of Documents

The following documents are to be submitted to ABS for approval.

- Outline of firms, e.g., organization and management structure.
- Experience of the firms on thickness measurement inter alia of hull structures of vessels.
- Technicians careers, i.e., experiences of technicians as thickness measurement operators, technical knowledge of hull structure, etc. Operators should be qualified according to a recognized industrial NDT standard.
- Equipment used for thickness measurement such as ultrasonic testing machines and its maintenance and calibration procedures.
- A guide for thickness measurement operators.
- Training programs of technicians for thickness measurement.

For Measurement record format, refer to Section 7-A-6 “Report on Thickness Measurement of Bulk Carriers”, Section 7-A-7 “Report on Thickness Measurement of Oil Carriers, Ore/Oil Ships and Chemical Carriers, etc. – Non Double Hull” and Section 7-A-13 “Report on Thickness Measurement of Oil Carriers, Ore/Oil Ships and Chemical Carriers, etc. – Double Hull” of this Appendix.

3.3 Auditing of the Firms

Upon reviewing the documents submitted with satisfactory results, the firm is audited in order to ascertain that the firm is duly organized and managed in accordance with the documents submitted and eventually is capable of conducting thickness measurement of the hull construction of vessels.

3.5 Onboard Demonstration

Certification is conditional on an onboard demonstration of thickness measurement as well as satisfactory reporting.

5 Certification

Upon satisfactory results of both the audit of the firm and the demonstration tests, ABS will issue a Certificate of Approval as well as a notice to the effect that the thickness measurement operation system of the firm has been certified by ABS.

Renewal/endorsement of the Certificate is to be made at intervals not exceeding three (3) years by a verification that original conditions are maintained.

7 Alteration to the Certified Thickness Measurement Operating System

In case where any alteration to the certified thickness measurement operation system of the firm is made, such an alteration is to be immediately informed to ABS. A re-audit may be made where considered necessary by ABS.

9 Cancellation of Approval

Approval may be canceled in the following cases:

- (1 July 2005) Where the measurements were improperly carried out.
- (1 July 2005) Where the measurement results were improperly reported or not reported in a timely manner.
- (1 July 2005) Where the Surveyor found any deficiencies in the approved thickness measurement operation systems of the firm and appropriate corrective action was not taken.
- Where the firm failed to inform ABS of any alteration of the certified thickness measurement operating system.

PART
7

APPENDIX

SECTION 6 Report on Thickness Measurement of Bulk Carriers – Non Double Skin (CSR and Non-CSR Vessels) and General Dry Cargo Vessels (*1 July 2013*)

1 Instructions

1.1 Non-CSR Vessels

1.1.1

This document is to be used for recording thickness measurements as required by the Enhanced Survey Program (see 7-3-2/5.7.5) and as required for General Dry Cargo Vessels (see 7-3-2/5.15.5).

1.1.2

Reporting forms TM1-BC, TM2-BC, TM3-BC, TM4-BC, TM5-BC, TM6-BC, TM7-BC and TM7 BC S31 are to be used for recording thickness measurements.

1.1.3

7-A-6/Figures 1 through 3 are guidance diagrams and notes relating to the reporting forms and the procedure for thickness measurement on Bulk Carriers – Non Double Skin. 7-A-6/Figure 4 is guidance diagrams and notes relating to the reporting forms and the procedure for thickness measurement on General Dry Cargo Vessels.

1.3 CSR Vessels

1.3.1

This document is to be used for recording thickness measurements of bulk carriers built under IACS Common Structural Rules (CSR) as required by the IACS unified Requirement Z10.2.

1.3.2

Reporting forms TM1-BC(CSR), TM2-BC(CSR) (i) and (ii), TM3-BC(CSR), TM4-BC(CSR), TM5-BC(CSR), TM6-BC(CSR) and TM7-BC(CSR) are to be used for recording thickness measurements.

1.3.3

The as-built thickness and voluntary thickness addition and renewal thickness (minimum allowable thickness) are to be stated in the said forms.

1.3.4

7-A-6/Figures 1 through 3 are guidance diagrams and notes relating to the reporting forms and the IACS unified Requirements for thickness measurement.

1.3.5

7-A-6/Figure 5 through 10 and 7-A-6/Table 1 are guidance diagrams and notes relating to the rule requirements for the locations and number of points to be measured for CSR bulk carriers.

1.5 Reporting Forms

The reporting forms should, where applicable, be supplemented by data presented on structural sketches.

General Particulars

Ships name:-

IMO number

ABS identification number

Port of registry:-

Gross tons:-

Deadweight:-

Date of build:-

Classification society:-

Name of Company performing thickness measurement:-

Thickness measurement company certified by:-

Certificate No.

Certificate valid from _____ to _____

Place of measurement

First date of measurement:-

Last date of measurement:-

Special Periodical Survey/Intermediate Survey due:-*

Details of measurement equipment:-

Qualification of operator:-

Report Number:-	consisting of	Sheets
-----------------	---------------	--------

Name of operator:-		Name of surveyor:-

Signature of operator:-		Signature of surveyor:-

Company official stamp:-		Classification Society Official Stamp:-

*Delete as appropriate.

TM1-BC (1 July 2006)

Report on THICKNESS MEASUREMENT of ALL DECK PLATING, ALL BOTTOM SHELL PLATING or SIDE SHELL PLATING*
 (* delete as appropriate)

Ship's Name _____

Class Identity No. _____

Report No. _____

STRAKE POSITION	PLATE POSITION	No. or Letter	Org thk mm	Forward Reading						Aft Reading						Mean Diminution %		Max. Alwb. Dim. mm
				Gauged		Diminution P		Diminution S		Gauged		Diminution P		Diminution S		P	S	
				P	S	mm	%	mm	%	P	S	mm	%	mm	%			
12th forward																		
11th																		
10th																		
9th																		
8th																		
7th																		
6th																		
5th																		
4th																		
3rd																		
2nd																		
1st																		
Amidships																		
1st aft																		
2nd																		
3rd																		
4th																		
5th																		
6th																		
7th																		
8th																		
9th																		
10th																		
11th																		
12th																		

Operators Signature _____

NOTES - See Reverse

NOTES

1. This report is to be used for recording the thickness measurement of:
 - 1.1 All strength deck plating within the cargo area.
 - 1.2 All keel, bottom shell plating within the cargo area.
 - 1.3 Side shell plating that is all wind and water strakes within the cargo area.
 - 1.4 Side shell plating that is selected wind and water strakes outside the cargo area.
2. The strake position is to be clearly indicated as follows:
 - 2.1 For strength deck, indicate the number of the strake of plating inboard from the stringer plate.
 - 2.2 For bottom plating, indicate the number of the strake of plating outboard from the keel plate.
 - 2.3 For side shell plating, give number of the strake of plating below sheerstrake and letter as shown on shell expansion.
3. Only the deck plating strakes outside line of openings are to be recorded.
4. Measurements are to be taken at the forward and aft areas of all plates and the single measurements recorded are to represent the average of multiple measurements.
5. The maximum allowable diminution could be stated in an attached document.

NOTES

1. This report is to be used for recording the thickness measurement of:
Strength deck plating and sheerstrake plating transverse sections:
Two or three sections within the cargo area, comprising the structural items (1), (2) and (3), as shown on the diagram of typical transverse section (See 7-A-6/Figure 1).
2. Only the deck plating strakes outside the line of openings are to be recorded.
3. The topside area comprises deck plating, stringer plate and sheerstrake (including rounded gunwales).
4. The exact frame station of measurement is to be stated.
5. The single measurements recorded are to represent the average of multiple measurements.
6. The maximum allowable diminution could be stated in an attached document.

TM2-BC(ii) (1 July 2006)

Report on THICKNESS MEASUREMENT OF SHELL AND DECK PLATING (one, two or three transverse sections)

Ship's Name _____ Class Identity No. _____ Report No. _____

SHELL PLATING																											
STRAKE POSITION	FIRST TRANSVERSE SECTION AT FRAME NUMBER								SECOND TRANSVERSE SECTION AT FRAME NUMBER								THIRD TRANSVERSE SECTION AT FRAME NUMBER										
	No. or Ltr	Org Thk mm	Max Alwb Dim. mm	Gauged		Diminution P		Diminution S		No. or Ltr	Org Thk mm	Max Alwb Dim. mm	Gauged		Diminution P		Diminution S		No. or Ltr	Org Thk mm	Max Alwb Dim. mm	Gauged		Diminution P		Diminution S	
				P	S	mm	%	mm	%				P	S	mm	%	mm	%				P	S	mm	%	mm	%
1st below sheer strake																											
2nd																											
3rd																											
4th																											
5th																											
6th																											
7th																											
8th																											
9th																											
10th																											
11th																											
12th																											
13th																											
14th																											
15th																											
16th																											
17th																											
18th																											
19th																											
20th																											
keel strake																											
BOTTOM TOTAL																											

Operators Signature _____

NOTES - See Reverse

NOTES

1. This report is to be used for recording the thickness measurement of:
Shell plating transverse sections:
Two or three sections within the cargo area comprising the structural items (4), (5), (6) and (7), as shown on the diagram of typical transverse section (See 7-A-6/Figure 1).
2. The bottom area comprises keel, bottom and bilge plating.
3. The exact frame station of measurement is to be stated.
4. The single measurements recorded are to represent the average of multiple measurements.
5. The maximum allowable diminution could be stated in an attached document.

TM3-BC (1 July 2006)

Report on THICKNESS MEASUREMENT OF LONGITUDINAL MEMBERS (one, two or three transverse sections)

Ship's Name _____

Class Identity No. _____

Report No. _____

STRUCTURAL MEMBER	FIRST TRANSVERSE SECTION AT FRAME NUMBER									SECOND TRANSVERSE SECTION AT FRAME NUMBER							THIRD TRANSVERSE SECTION AT FRAME NUMBER										
	Item No.	Org Thk	Max Alwb Dim.	Gauged		Diminution P		Diminution S		Item No.	Org Thk	Max Alwb Dim.	Gauged		Diminution P		Diminution S		Item No.	Org Thk	Max Alwb Dim.	Gauged		Diminution P		Diminution S	
				P	S	mm	%	mm	%				P	S	mm	%	mm	%				P	S	mm	%	mm	%
		mm	mm								mm	mm										mm	mm				

Operators Signature _____

NOTES - See Reverse

NOTES

1. This report is to be used for recording the thickness measurement of:
Longitudinal Members at transverse sections:
Two or three sections within the cargo area, comprising the structural items (8) to (20), as shown on the diagram of typical transverse section (See 7-A-6/Figure 1).
2. The exact frame station of measurement is to be stated.
3. The single measurements recorded are to represent the average of multiple measurements.
4. The maximum allowable diminution could be stated in an attached document.

TM4-BC (1 July 2006)

Report on THICKNESS MEASUREMENT OF TRANSVERSE STRUCTURAL MEMBERS
In the double bottom, hopper side and topside water ballast tanks

Ship's Name _____ Class Identity No. _____ Report No. _____

TANK DESCRIPTION :									
LOCATION OF STRUCTURE :									
STRUCTURAL MEMBER	ITEM	Original Thickness mm	Maximum Allowable Diminution mm	Gauged		Diminution P		Diminution S	
				Port	Starboard	mm	%	mm	%

Operators Signature _____

NOTES - See Reverse

NOTES

1. This report is to be used for recording the thickness measurement of transverse structural members, comprising the appropriate structural items (23) to (25), as shown on diagram of typical transverse section (See 7-A-6/Figure 1).
2. Guidance for areas of measurement is indicated on the diagrams shown on 7-A-6/Figure 3.
3. The single measurements recorded are to represent the average of multiple measurements.
4. The maximum allowable diminution could be stated in an attached document.

TM5-BC (1 July 2006)

Report on THICKNESS OF CARGO HOLD TRANSVERSE BULKHEADS

Ship's Name _____ Class Identity No. _____ Report No. _____

LOCATION OF STRUCTURE :			FRAME NO. :					
STRUCTURAL COMPONENT (PLATING/STIFFENER)	Original Thickness mm	Maximum Allowable Diminution mm	Gauged		Diminution P		Diminution S	
			Port	Starbd	mm	%	mm	%

Operators Signature _____

NOTES - See Reverse

NOTES

1. This report form is to be used for recording the thickness measurement of cargo hold transverse bulkheads.
2. Guidance for areas of measurement is indicated on the diagrams shown on 7-A-6/Figure 3.
3. The single measurements recorded are to represent the average of multiple measurements.
4. The maximum allowable diminution could be stated in an attached document.

TM6-BC (1 July 2006)

Report on THICKNESS MEASUREMENT OF MISCELLANEOUS STRUCTURAL MEMBERS

Ship's Name _____ Class Identity No. _____ Report No. _____

STRUCTURAL MEMBER :								SKETCH	
LOCATION OF STRUCTURE :									
Description	Org Thk. mm	Maximum Allowable Diminution mm	Gauged		Diminution P		Diminution S		
			P	S	mm	%	mm	%	

Operators Signature _____

NOTES - See Reverse

NOTES

1. This report form is to be used for recording the thickness measurement of miscellaneous structural members, including the structural items (28), (29), (30) and (31), as shown on diagram of typical transverse section (See 7-A-6/Figure 1).
2. Guidance for areas of measurement is indicated on the diagrams shown on 7-A-6/Figure 3.
3. The single measurements recorded are to represent the average of multiple measurements.
4. The maximum allowable diminution could be stated in an attached document.

TM7-BC (1 July 2006)

Report on THICKNESS MEASUREMENT OF CARGO HOLD TRANSVERSE FRAMES

Ship's Name _____ Class Identity No. _____ Report No. _____

CARGO HOLD NO. _____																								
FRAME NUMBER	UPPER PART								MID PART								LOWER PART							
	Orig Thk	Max Alwb Dim.	Gauged		Diminution P		Diminution S		Org Thk	Max Alwb Dim.	Gauged		Diminution P		Diminution S		OrgThhk	Max Alwb Dim.	Gauged		Diminution P		Diminution S	
	mm	mm	P	S	mm	%	mm	%	mm	mm	P	S	mm	%	mm	%	mm	mm	P	S	mm	%	mm	%

Operators Signature _____

NOTES - See Reverse

NOTES

1. This report is to be used for recording the thickness measurement of:
 Cargo Hold Transverse Frames.
 Structural item number 34, as shown on the diagram of typical transverse section (See 7-A-6/Figure 1).
2. Guidance for areas of measurement is indicated on the diagrams shown on 7-A-6/Figure 3. The single measurements recorded are to represent the average of multiple measurements.
3. The location and pattern of measurements is to be indicated on the sketches of hold frames shown below.

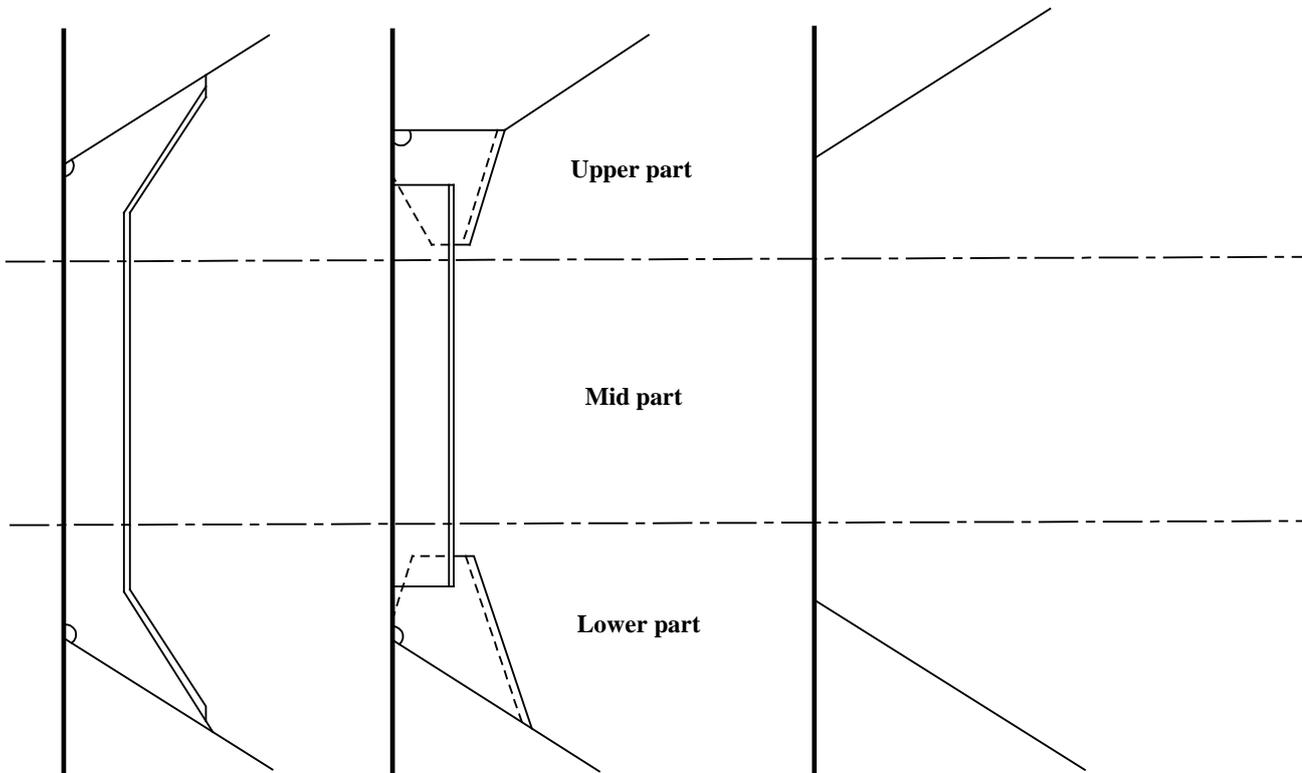

Typical transverse frames in cargo hold
 Thickness gauging area (A)

Non - typical transverse
 frame in cargo hold
 Thickness gauging area (A)

4. The maximum allowable diminution could be stated in an attached document.

Report on THICKNESS MEASUREMENT OF CARGO HOLD SIDE SHELL FRAMES

TM7-BC-S31 (1 July 2006)

Ship's Name _____ Class Identity No. _____ Report No. _____

FRAME NO.	CARGO HOLD NO.: Side (Port/Stb.)																								
	ZONE A						ZONE B						ZONE C						ZONE D						
	Org. Thk.	t _{REN}	t _{COAT}	t _M	Diminution		Org. Thk.	t _{REN}	t _{COAT}	t _M	Diminution		Org. Thk.	t _{REN}	t _{COAT}	t _M	Diminution		Org. Thk.	t _{REN}	t _{COAT}	t _M	Diminution		
mm	mm	mm	mm	mm	%	mm	mm	mm	mm	mm	%	mm	mm	mm	mm	mm	%	mm	mm	mm	mm	mm	%		

Operators Signature _____

NOTES - See Reverse

NOTES

1. This report is to be used for recording the thickness measurement of:
Cargo Hold Transverse Frames for application of UR S31.
Structural item number 34, as shown on the diagram of typical transverse section (See 7-A-6/Figure 1).
2. The maximum allowable diminution could be stated in an attached document.

TM1-BC(CSR) (1 July 2013)

Report on THICKNESS MEASUREMENT of ALL DECK PLATING, ALL BOTTOM PLATING or SIDE SHELL PLATING*
 (* delete as appropriate)

Ship's Name _____

Class Identity No. _____

Report No. _____

STRAKE POSITION	PLATE POSITION	No. or Letter	As Built Thk. mm	Voluntary Thickness Addition mm	Renewal Thickness mm (a)	Forward Reading				Aft Reading				Mean Remaining Corr. Addition, mm [(c1) + (c2)]/2			
						Gauged Thk. mm (b1)		Remaining Corr. Addition, mm (c1) = (b1) - (a)		Gauged Thk. mm (b1)		Remaining Corr. Addition, mm (c1) = (b1) - (a)		P	S		
						P	S	P	S	P	S	P	S	P	S		
12th forward																	
11th																	
10th																	
9th																	
8th																	
7th																	
6th																	
5th																	
4th																	
3rd																	
2nd																	
1st																	
Amidships																	
1st aft																	
2nd																	
3rd																	
4th																	
5th																	
6th																	
7th																	
8th																	
9th																	
10th																	
11th																	
12th																	

Operators Signature _____

NOTES - See Reverse

NOTES TO REPORT TM1-BC(CSR)

1. This report is to be used for recording the thickness measurement of:
 - 1.1 All strength deck plating within cargo length area.
 - 1.2 Keel, bottom shell plating and bilge plating within the cargo length area.
 - 1.3 Side shell plating that is all wind and water strakes within the cargo length area.
 - 1.4 Side shell plating that is selected wind and water strakes outside the cargo length area.
2. The strake position is to be clearly indicated as follows:-
 - 2.1 For strength deck indicate the number of the strake of plating inboard from the stringer plate.
 - 2.2 For bottom plating indicate the number of the strake of plating outboard from the keel plate.
 - 2.3 For side shell plating give number of the strake of plating sheerstrake and letter as shown on shell expansion.
3. Only the deck plating strakes outside line of openings are to be recorded.
4. Measurements are to be taken at the forward and aft areas of all plates and the single measurements recorded are to represent the average of multiple measurements.
5. The remaining corrosion addition is to be recorded with result of gauged thickness minus renewal thickness. If the result is negative, the structure in way shall be renewed, and the mark “R” is to be indicated in the right-hand column. If the result is between 0 and 0.5 mm (0 included), the structure in way shall be additional gauged, and the mark “S” is to be indicated in the right-hand column.

NOTES TO REPORT TM2-BC(CSR) (i)

1. This report is to be used for recording the thickness measurement of:
Strength deck plating and sheerstrake plating transverse sections:
One, two or three sections within the cargo length area, comprising of the structural items (1), (2) and (3) as shown on the diagram of typical transverse section, 7-A-6/Figure 1.
2. Only the deck plating strakes outside the line of openings are to be recorded.
3. The topside area comprises deck plating, stringer plate and sheerstrake (including rounded gunwales).
4. The exact frame station of measurement is to be stated.
5. The single measurements recorded are to represent the average of multiple measurements.
6. The remaining corrosion addition is to be recorded with result of gauged thickness minus renewal thickness. If the result is negative, the structure in way shall be renewed, and the mark “R” is to be indicated in the right-hand column. If the result is between 0 and 0.5 mm (0 included), the structure in way shall be additional gauged, and the mark “S” is to be indicated in the right-hand column.

TM2-BC(CSR) (ii) (1 July 2013)

Report on THICKNESS MEASUREMENT OF SHELL PLATING (one, two or three transverse sections)

Ship's Name _____

Class Identity No. _____

Report No. _____

SHELL PLATING																								
STRAKE POSITION	FIRST TRANSVERSE SECTION AT FRAME NUMBER							SECOND TRANSVERSE SECTION AT FRAME NUMBER							THIRD TRANSVERSE SECTION AT FRAME NUMBER									
	No. or Ltr	As Built Thk. mm	Vol. Thk. Add mm	Ren. Thk. mm (a)		Gauged Thk. mm (b)		Remaining Corr. Addition, mm (b) - (a)		No. or Ltr	As Built Thk. mm	Vol. Thk. Add mm	Ren. Thk. mm (a)	Gauged Thk. mm (b)		Remaining Corr. Addition, mm (b) - (a)	No. or Ltr	As Built Thk. mm	Vol. Thk. Add mm	Ren. Thk. mm (a)	Gauged Thk. mm (b)		Remaining Corr. Addition, mm (b) - (a)	
				P	S	P	S	P	S					P	S						P	S	P	S
1st below sheer strake																								
2nd																								
3rd																								
4th																								
5th																								
6th																								
7th																								
8th																								
9th																								
10th																								
11th																								
12th																								
13th																								
14th																								
15th																								
16th																								
17th																								
18th																								
19th																								
20th																								
Keel strake																								
BOTTOM TOTAL																								

Operators Signature _____

NOTES - See Reverse

NOTES TO REPORT TM2-BC(CSR) (ii)

1. This report is to be used for recording the thickness measurement of:
Shell plating transverse sections:
One, two or three sections within cargo length area comprising of the structural items (4), (5), (6) and (7) as shown on the diagram of typical transverse section, 7-A-6/Figure 1.
2. The bottom area comprises keel, bottom and bilge plating.
3. The exact frame station of measurement is to be stated.
4. The single measurements recorded are to represent the average of multiple measurements.
5. The remaining corrosion addition is to be recorded with result of gauged thickness minus renewal thickness. If the result is negative, the structure in way shall be renewed, and the mark “R” is to be indicated in the right-hand column. If the result is between 0 and 0.5 mm (0 included), the structure in way shall be additional gauged, and the mark “S” is to be indicated in the right-hand column.

TM3-BC(CSR) (1 July 2013)

Report on THICKNESS MEASUREMENT OF LONGITUDINAL MEMBERS (one, two or three transverse sections)

Ship's Name _____

Class Identity No. _____

Report No. _____

STRUCTURAL MEMBER	FIRST TRANSVERSE SECTION AT FRAME NUMBER								SECOND TRANSVERSE SECTION AT FRAME NUMBER								THIRD TRANSVERSE SECTION AT FRAME NUMBER							
	Item No.	As Built Thk. mm	Vol. Thk. Add mm	Ren. Thk. mm (a)	Gauged Thk. mm (b)		Remaining Corr. Addition, mm (b) – (a)		Item No.	As Built Thk. mm	Vol. Thk. Add mm	Ren. Thk. mm (a)	Gauged Thk. mm (b)		Remaining Corr. Addition, mm (b) – (a)		Item No.	As Built Thk. mm	Vol. Thk. Add mm	Ren. Thk. mm (a)	Gauged Thk. mm (b)		Remaining Corr. Addition, mm (b) – (a)	
					P	S	P	S					P	S	P	S					P	S	P	S

Operators Signature _____

NOTES - See Reverse

NOTES TO REPORT TM3-BC(CSR)

1. This report is to be used for recording the thickness measurement of:
Longitudinal Members at transverse sections:
One, two, or three sections within the cargo length area, comprising of the appropriate structural items (8) to (20) as shown on diagram of typical transverse section, 7-A-6/Figure 1.
2. The exact frame station of measurement is to be stated.
3. The single measurements recorded are to represent the average of multiple measurements.
4. The remaining corrosion addition is to be recorded with result of gauged thickness minus renewal thickness. If the result is negative, the structure in way shall be renewed, and the mark “R” is to be indicated in the right-hand column. If the result is between 0 and 0.5 mm (0 included), the structure in way shall be additional gauged, and the mark “S” is to be indicated in the right-hand column.

TM4-BC(CSR) (1 July 2013)

Report on THICKNESS MEASUREMENT OF TRANSVERSE STRUCTURAL MEMBERS
In the double bottom, hopper side and topside water ballast tanks

Ship's Name _____ Class Identity No. _____ Report No. _____

TANK DESCRIPTION :									
LOCATION OF STRUCTURE :									
STRUCTURAL MEMBER	ITEM	As Built Thickness mm	Voluntary Thickness Addition mm	Renewal Thickness mm (a)	Gauged Thickness mm (b)		Remaining Corr. Addition mm (b) – (a)		
					P	S	P	S	

Operators Signature _____

NOTES - See Reverse

NOTES TO REPORT TM4-BC(CSR)

1. This report is to be used for recording the thickness measurement of transverse structural members, comprising of the appropriate structural items (23) to (25) as shown on diagram of typical transverse section, 7-A-6/Figure 1.
2. Guidance for areas if measurement is indicated on the diagrams shown on 7-A-6/Figure 3.
3. The single measurements recorded are to represent the average of multiple measurements.
4. The remaining corrosion addition is to be recorded with result of gauged thickness minus renewal thickness. If the result is negative, the structure in way shall be renewed, and the mark “R” is to be indicated in the right-hand column. If the result is between 0 and 0.5 mm (0 included), the structure in way shall be additional gauged, and the mark “S” is to be indicated in the right-hand column.

TM5-BC(CSR) (1 July 2013)

Report on THICKNESS MEASUREMENT OF CARGO HOLD TRANSVERSE BULKHEADS

Ship's Name _____ Class Identity No. _____ Report No. _____

HOLD DESCRIPTION :									
LOCATION OF STRUCTURE :				FRAME NO:					
STRUCTURAL COMPONENT (PLATING/STIFFENER)	As Built Thickness mm	Voluntary Thickness Addition mm	Renewal Thickness mm (a)	Gauged Thickness mm (b)		Remaining Corr. Addition mm (b) – (a)			
				P	S	P		S	

Operators Signature _____

NOTES - See Reverse

NOTES TO REPORT TM5-BC(CSR)

1. This report form is to be used for recording the thickness measurement of cargo hold transverse bulkheads.
2. Guidance for areas of measurement is indicated on the diagrams shown on 7-A-6/Figure 3.
3. The single measurements recorded are to represent the average of multiple measurements.
4. The remaining corrosion addition is to be recorded with result of gauged thickness minus renewal thickness. If the result is negative, the structure in way shall be renewed, and the mark “R” is to be indicated in the right-hand column. If the result is between 0 and 0.5 mm (0 included), the structure in way shall be additional gauged, and the mark “S” is to be indicated in the right-hand column.

TM6-BC(CSR) (1 July 2013)

Report on THICKNESS MEASUREMENT OF MISCELLANEOUS STRUCTURAL MEMBERS

Ship's Name _____ Class Identity No. _____ Report No. _____

STRUCTURAL MEMBER :						SKETCH							
LOCATION OF STRUCTURE :													
Description	As Built Thk. mm	Voluntary thickness Addition mm	Renewal Thickness mm (a)	Gauged Thickness mm (b)						Remaining Corr. Addition mm (b) – (a)			
				P	S					P	S	P	S

Operators Signature _____

NOTES - See Reverse

NOTES TO REPORT TM6-BC(CSR)

1. This report is to be used for recording the thickness measurement of miscellaneous structural members including the structural items (28), etc. as shown on diagram of typical transverse section, 7-A-6/Figure 1.
2. Guidance for areas of measurement is indicated on 7-A-6/Figure 3.
3. The single measurements recorded are to represent the average of multiple measurements.
4. The remaining corrosion addition is to be recorded with result of gauged thickness minus renewal thickness. If the result is negative, the structure in way shall be renewed, and the mark “R” is to be indicated in the right-hand column. If the result is between 0 and 0.5 mm (0 included), the structure in way shall be additional gauged, and the mark “S” is to be indicated in the right-hand column.

TM7-BC(CSR) (1 July 2013)

Report on THICKNESS MEASUREMENT OF CARGO HOLD TRANSVERSE FRAMES

Ship's Name _____ Class Identity No. _____ Report No. _____

CARGO HOLD NO.																								
FRAME NUMBER	UPPER PART								MID PART								LOWER PART							
	As Built Thk. mm	Volun. Thk. Add. mm	Renew. Thk. mm (a)	Gauged Thickness mm (b)		Remaining Corr. Addition mm (b) – (a)		As Built Thk. mm	Volun. Thk. Add. mm	Renew. Thk. mm	Gauged Thickness mm (b)		Remaining Corr. Addition mm (b) – (a)		As Built Thk. mm	Volun. Thk. Add. mm	Renew. Thk. mm	Gauged Thickness mm (b)		Remaining Corr. Addition mm (b) – (a)				
				P	S	P	S				P	S	P	S				P	S					

Operators Signature _____

NOTES - See Reverse

NOTES TO REPORT TM7-BC(CSR)

1. This report is to be used for recording the thickness measurement of:
 Cargo Hold Transverse Frames.
 Structural item number 34 as shown on the diagram of typical transverse section, 7-A-6/Figure 1.
2. Guidance for areas of measurement is indicated on the diagrams shown on 7-A-6/Figure 3 of this document.
 The single measurements recorded are to represent the average of multiple measurements.
3. The location and pattern of measurements is to be indicated on the sketches of hold frames shown below.

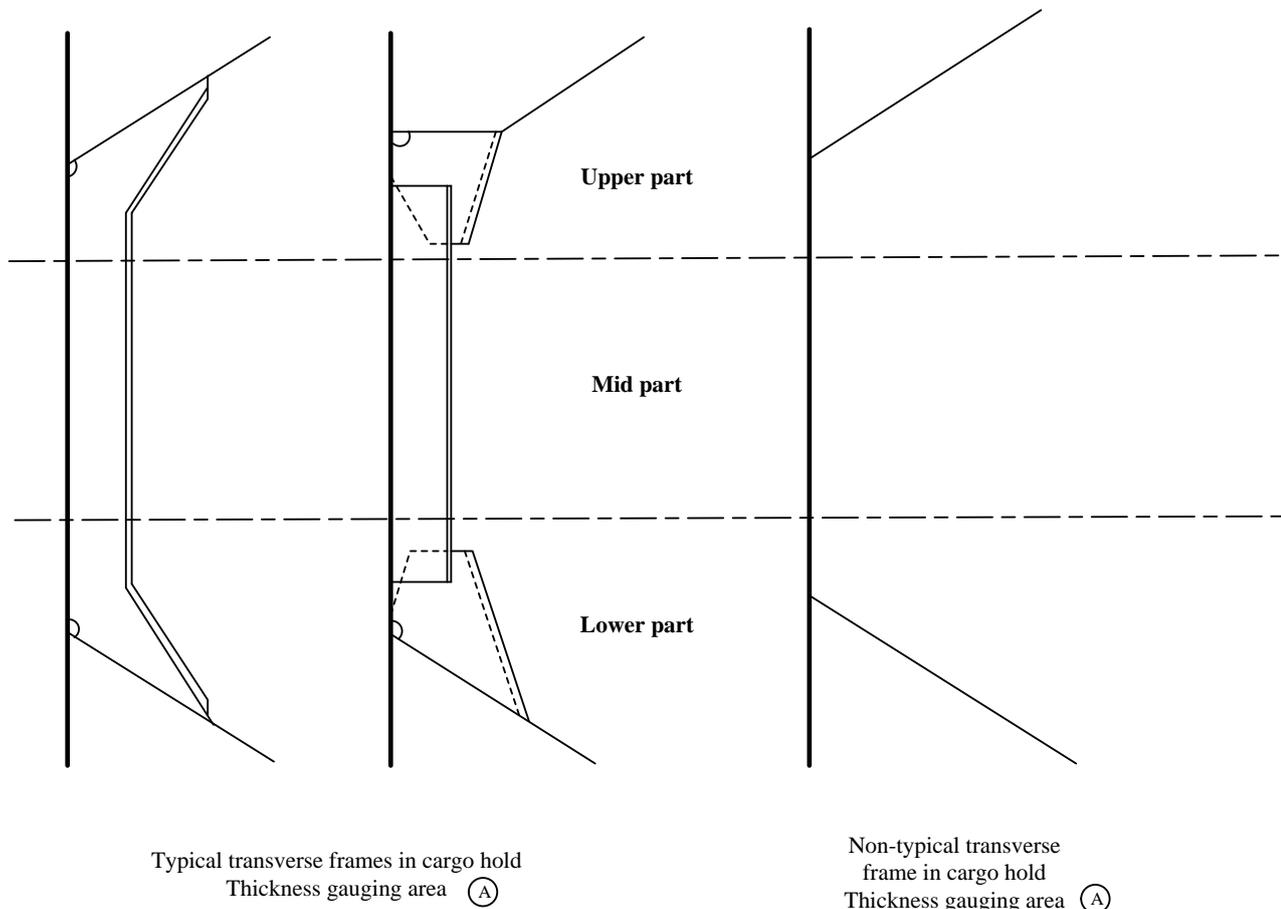

4. The remaining corrosion addition is to be recorded with result of gauged thickness minus renewal thickness. If the result is negative, the structure in way shall be renewed, and the mark “R” is to be indicated in the right-hand column. If the result is between 0 and 0.5 mm (0 included), the structure in way shall be additional gauged, and the mark “S” is to be indicated in the right-hand column.

FIGURE 1
THICKNESS MEASUREMENT – BULK CARRIERS (1 July 2013)

Bulk Carriers: Typical transverse section indicating longitudinal and transverse members

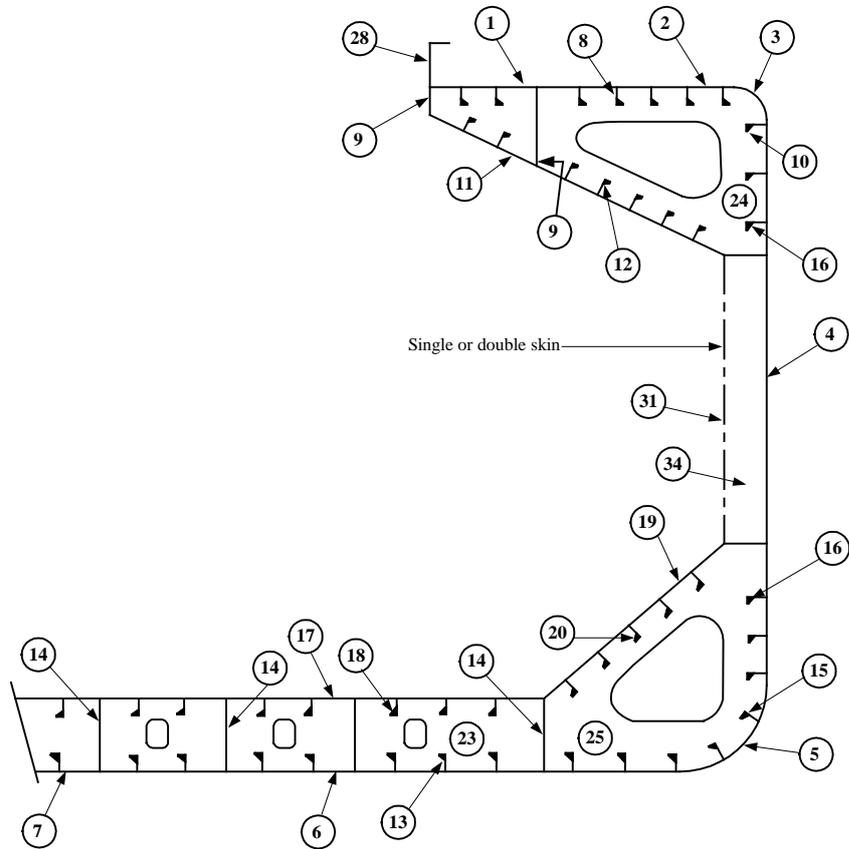

REPORT ON TM2-BC or TM2-BC(CSR) (i) & (ii)
1. Strength deck plating
2. Stringer plate
3. Sheerstrake
4. Side shell plating
5. Bilge plating
6. Bottom shell plating
7. Keel plate

REPORT ON TM3-BC or TM3-BC(CSR)	
8. Deck longitudinals	16. Side shell longitudinals
9. Deck girders	17. Inner bottom plating
10. Sheerstrake longitudinals	18. Inner bottom longitudinals
11. Topside tank sloping plating	19. Hopper side plating
12. Topside tank sloping plating longitudinals	20. Hopper side longitudinals
13. Bottom longitudinals	21.
14. Bottom girders	22.
15. Bilge longitudinals	

REPORT ON TM4-BC or TM4-BC(CSR)
23. Double bottom tank floors
24. Topside tank transverses
25. Hopper side tank transverses
26.
27.

REPORT ON TM6-BC or TM6-BC(CSR)
28. Hatch coamings
29. Deck plating between hatches
30. Hatch covers
31. Inner bulkhead plating
32.
33.

REPORT ON TM7-BC or TM7-BC(CSR)
34. Hold frames or diaphragms

FIGURE 2
THICKNESS MEASUREMENT – BULK CARRIERS (1 July 2013)

Bulk Carriers: Transverse section outline

To be used for longitudinal and transverse members where the typical Bulk Carrier section is not applicable.

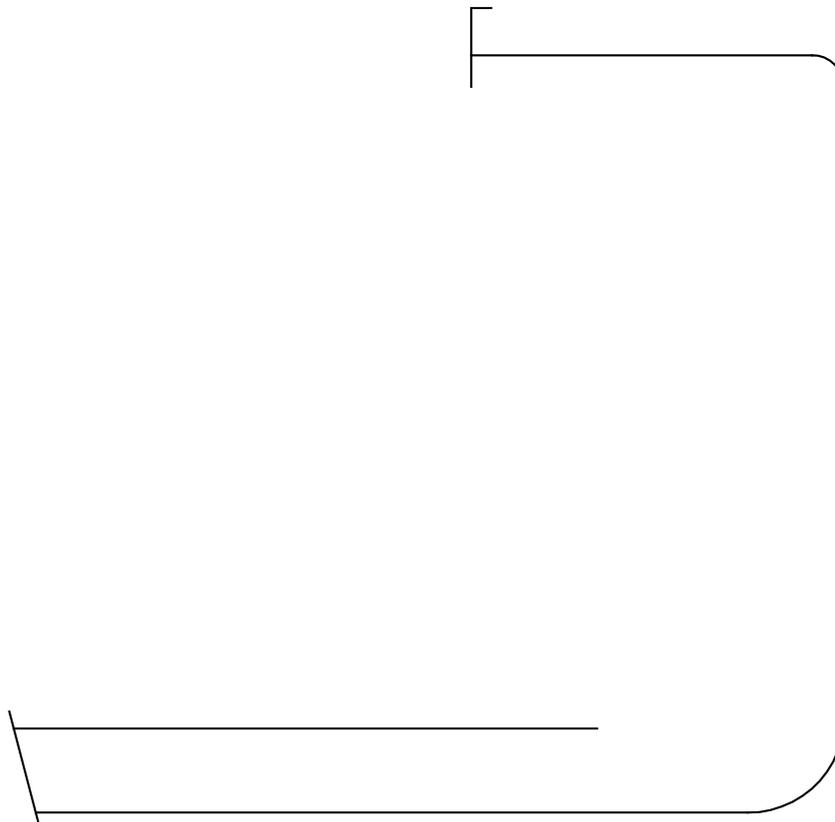

REPORT ON TM2-BC or TM2-BC(CSR) (i) & (ii)
1. Strength deck plating
2. Stringer plate
3. Sheerstrake
4. Side shell plating
5. Bilge plating
6. Bottom shell plating
7. Keel plate

REPORT ON TM3-BC or TM3-BC(CSR)	
8. Deck longitudinals	16. Side shell longitudinals
9. Deck girders	17. Inner bottom plating
10. Sheerstrake longitudinals	18. Inner bottom longitudinals
11. Topside tank sloping plating	19. Hopper side plating
12. Topside tank sloping plating longitudinals	20. Hopper side longitudinals
13. Bottom longitudinals	21.
14. Bottom girders	22.
15. Bilge longitudinals	

REPORT ON TM4-BC or TM4-BC(CSR)
23. Double bottom tank floors
24. Topside tank transverses
25. Hopper side tank transverses
26.
27.

REPORT ON TM6-BC or TM6-BC(CSR)
28. Hatch coamings
29. Deck plating between hatches
30. Hatch covers
31. Inner bulkhead plating
32.
33.

REPORT ON TM7-BC or TM7-BC(CSR)
34. Hold frames or diaphragms

FIGURE 3
Close-up Survey and Thickness Measurement Areas (1 July 2013)

Typical transverse section
 Areas **A**, **B** and **D**

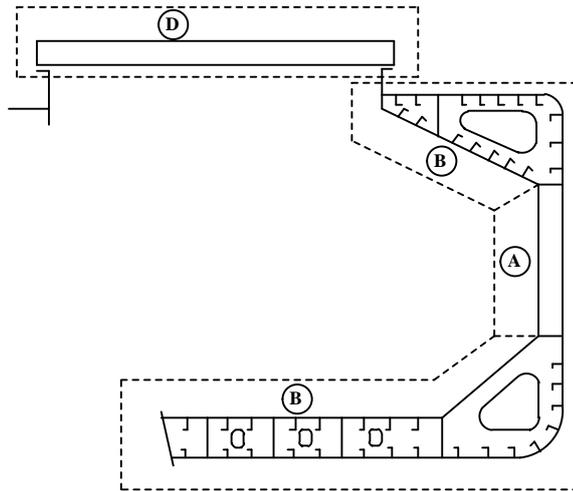

Thickness to be reported on TM3-BC, TM4-BC, TM6-BC and TM7-BC or TM3-BC(CSR), TM4-BC(CSR), TM6-BC(CSR) and TM7-BC(CSR), as appropriate

A cargo hold, transverse bulkhead
 Area **C**

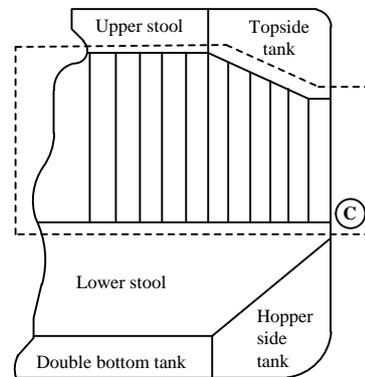

Thickness to be reported on TM5-BC or TM5-BC(CSR)

Typical areas of deck plating inside line
 of hatch openings between cargo hold hatches
 Area **E**

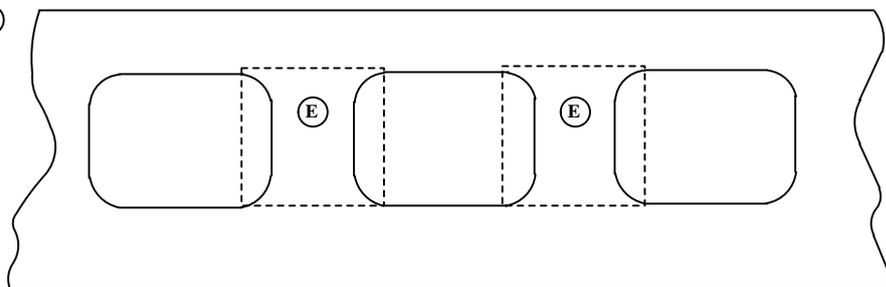

Thickness to be reported on TM6-BC or TM6-BC(CSR)

FIGURE 4
Areas for Close-Up Survey of General Dry Cargo Ships (2004)

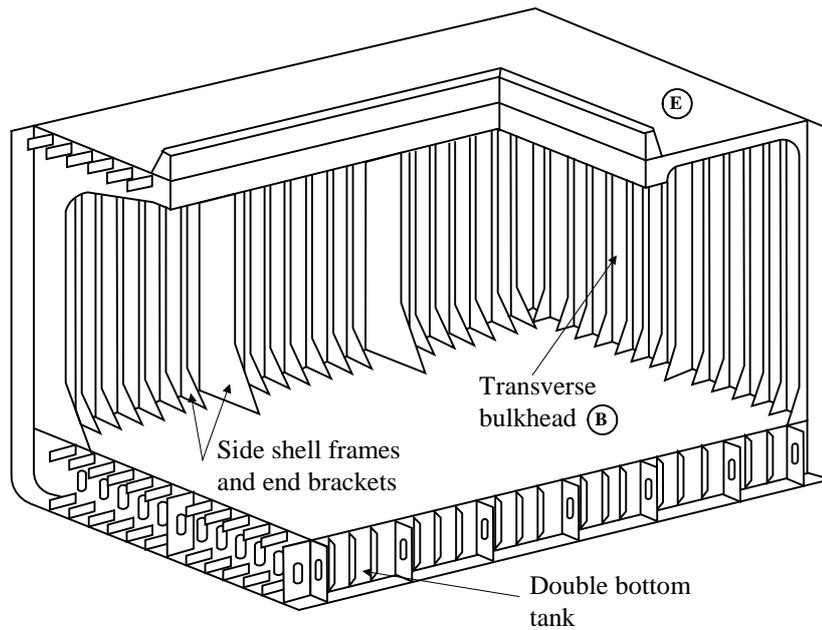

Single Deck Ship

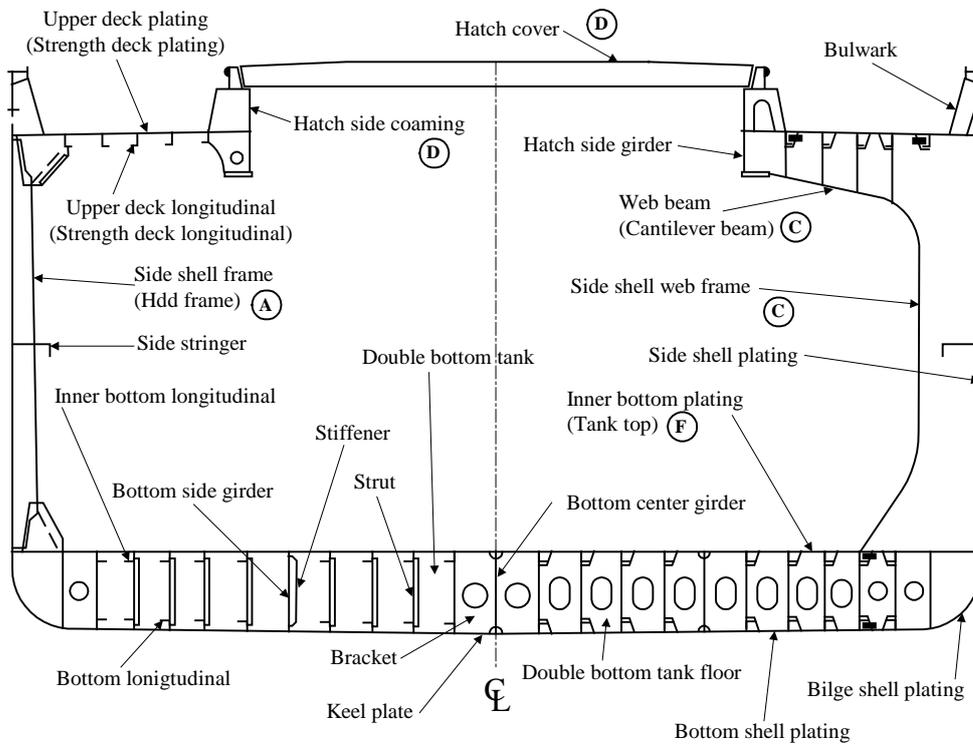

Single Deck Ship

FIGURE 4 (continued)
Areas for Close-Up Survey of General Dry Cargo Ships (2004)

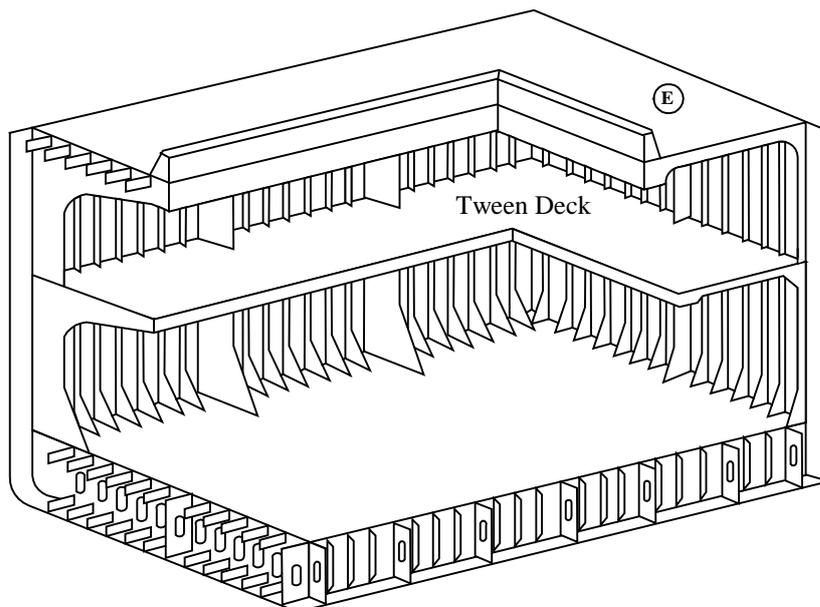

Tween Deck Ship

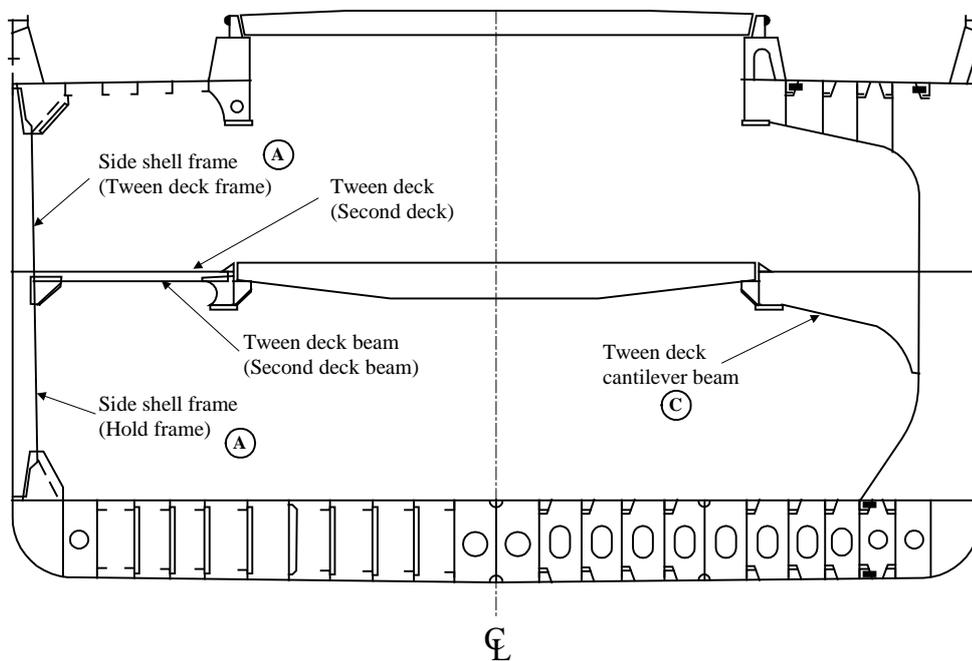

Tween Deck Ship

FIGURE 5
Transverse Section of Single Skin Bulk Carrier (1 July 2013)

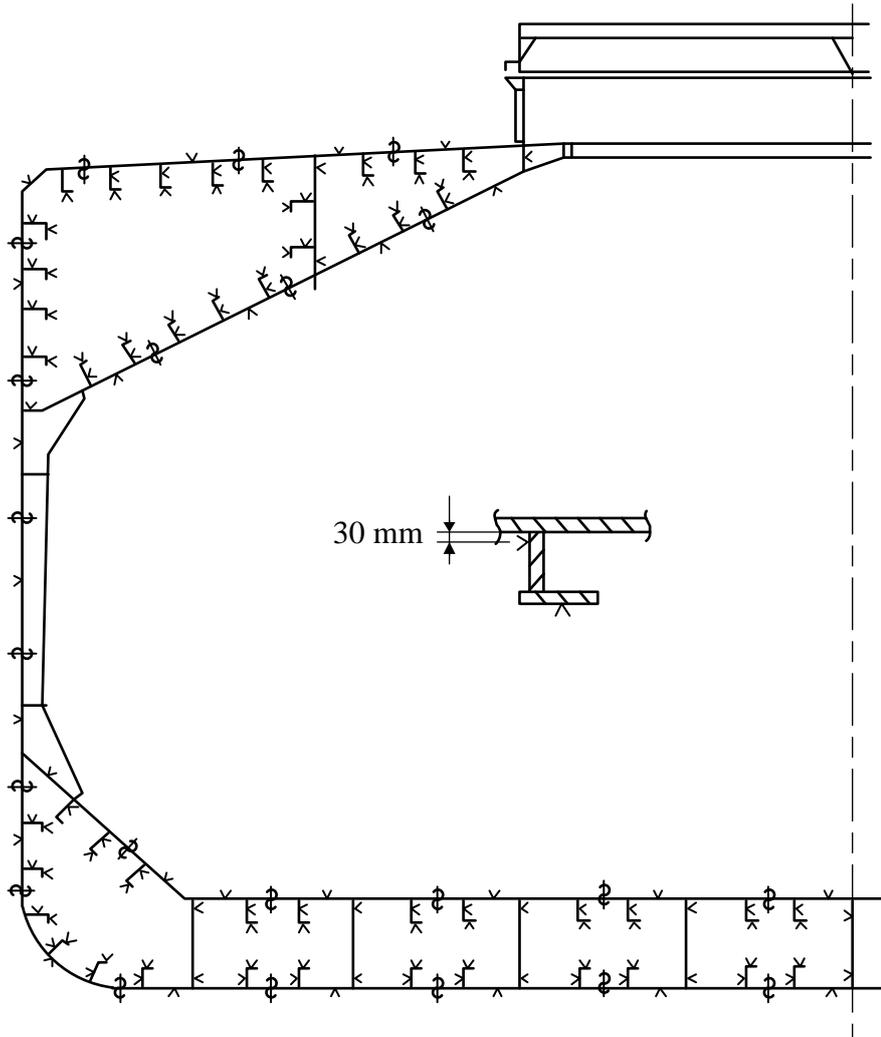

Single side bulk carriers

Note: Measurements are to be taken on both port and starboard sides of the selected transverse section.

FIGURE 6
Locations of Measurements on Hatch Covers and Coamings (1 July 2013)

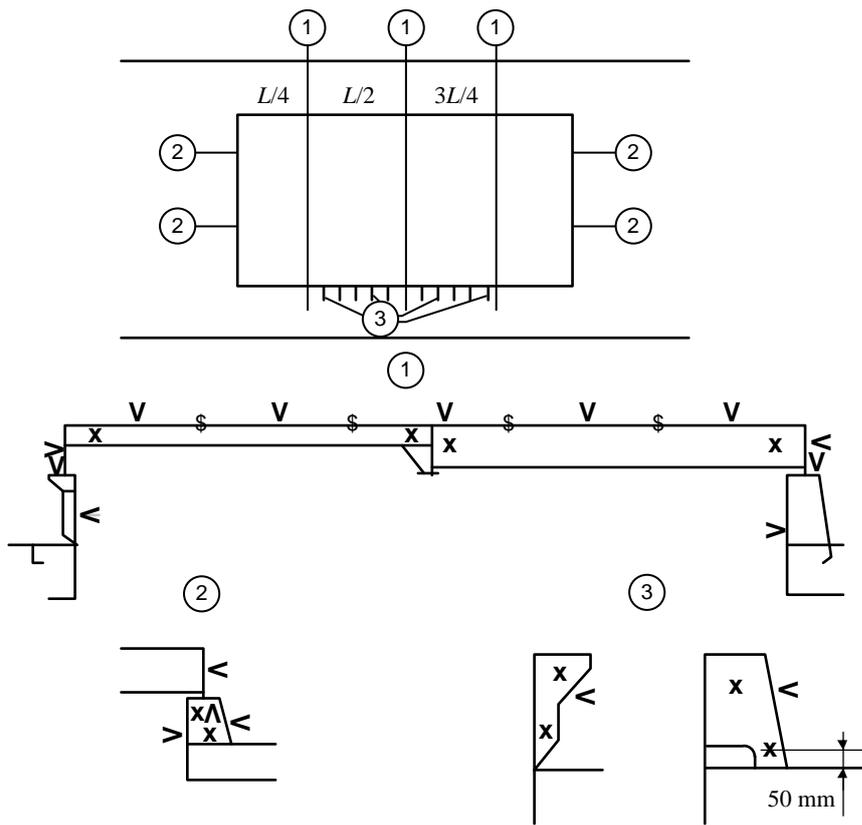

Notes:

- 1 Three sections at $L/4$, $L/2$, $3L/4$ of hatch cover length, including:
 - One measurement of each hatch cover plate and skirt plate
 - Measurements of adjacent beams and stiffeners
 - One measurement of coaming plates and coaming flange, each side
- 2 Measurements of both ends of hatch cover skirt plate, coaming plate, and coaming flange.
- 3 One measurement (two points for web plate and one point for face plate) of one out of three hatch coaming brackets and bars, on both sides and both ends.

FIGURE 7
Locations of Measurements on Structural Members in Cargo Holds and Ballast Tanks of Single Side Skin Bulk Carriers (1 July 2013)

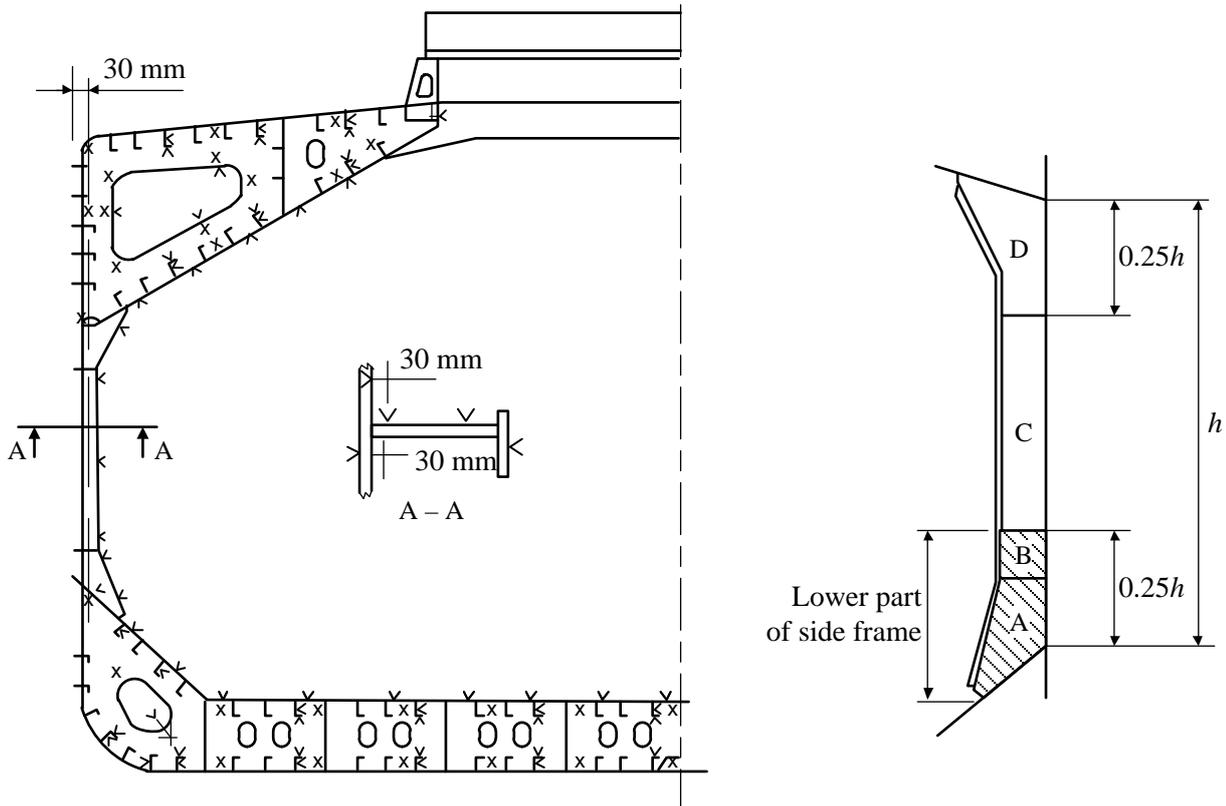

Note: The gauging pattern for web plating is to be a three-point pattern for zones A, C, and D, and a two-point pattern for zone B (see figure). The gauging report is to reflect the average reading. The average reading is to be compared with the allowable thickness. If the web plating has general corrosion, then this pattern is to be expanded to a five-point pattern.

FIGURE 8
Locations of Measurements on Cargo Hold Transverse Bulkheads (1 July 2013)

(Additional measurements to internal structure of upper and lower stools to be added, e.g. two points in the upper and two points in the lower stools to be indicated in Section A-A)

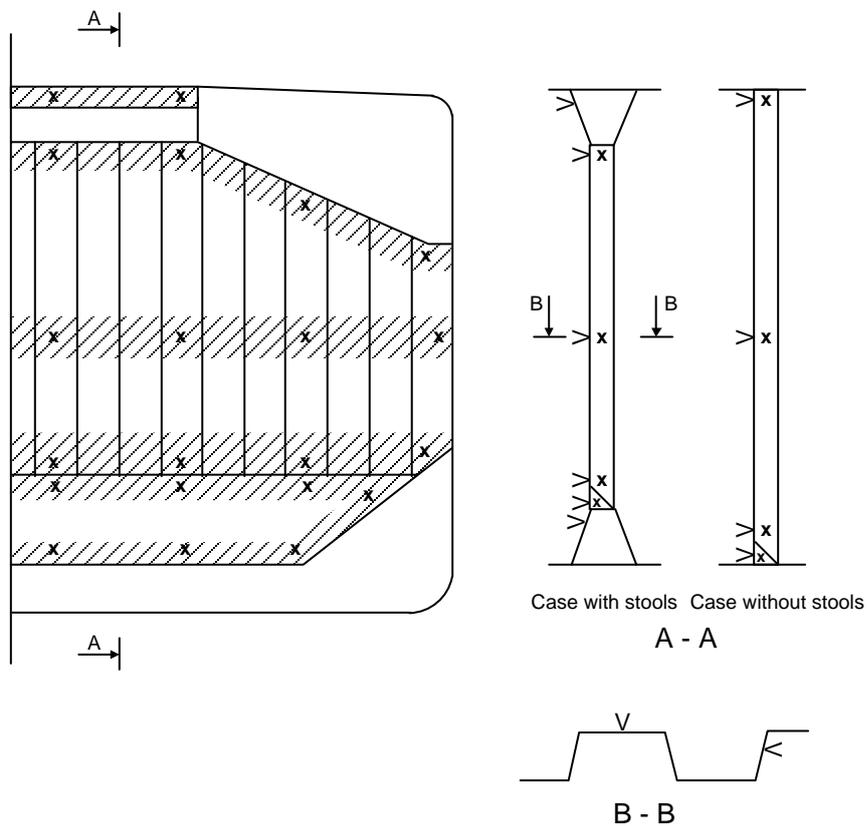

Note: Measurements to be taken in each shaded area as per views A - A and B - B.

FIGURE 9
Locations of Measurements on Transverse Bulkheads of Topside, Hopper
and Double Bottom Tanks (1 July 2013)

(Two additional measurements to internal structure of double bottom tank to be added at midspan)

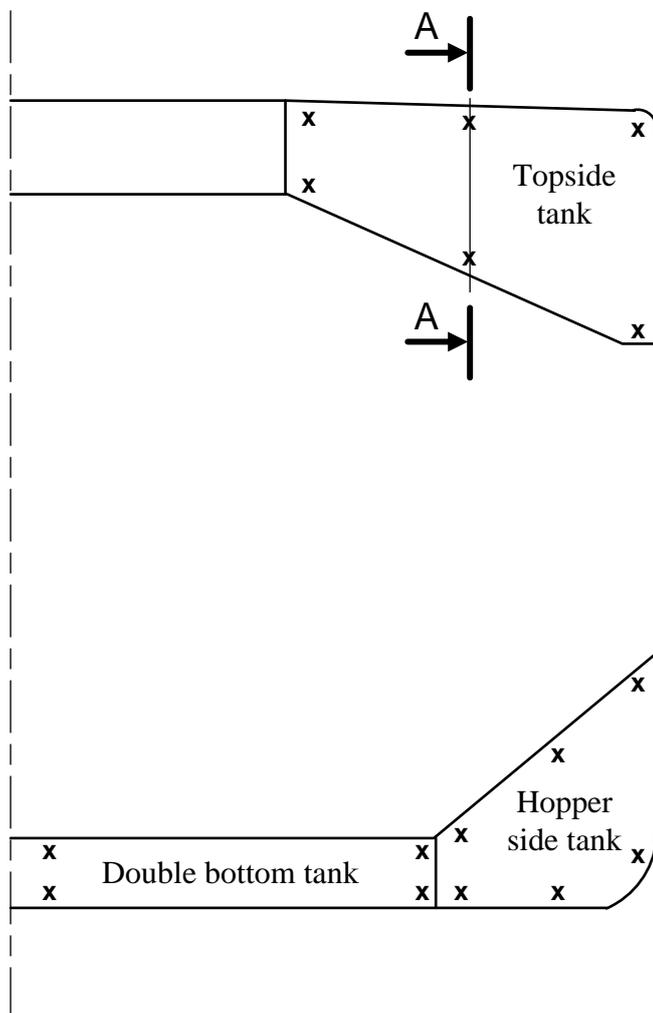

Section A - A

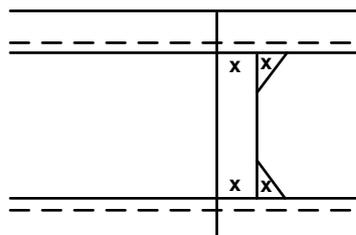

Note: Measurements to be taken in each vertical section as per view A - A.

FIGURE 10
Locations of Measurements on Underdeck Structure (1 July 2013)

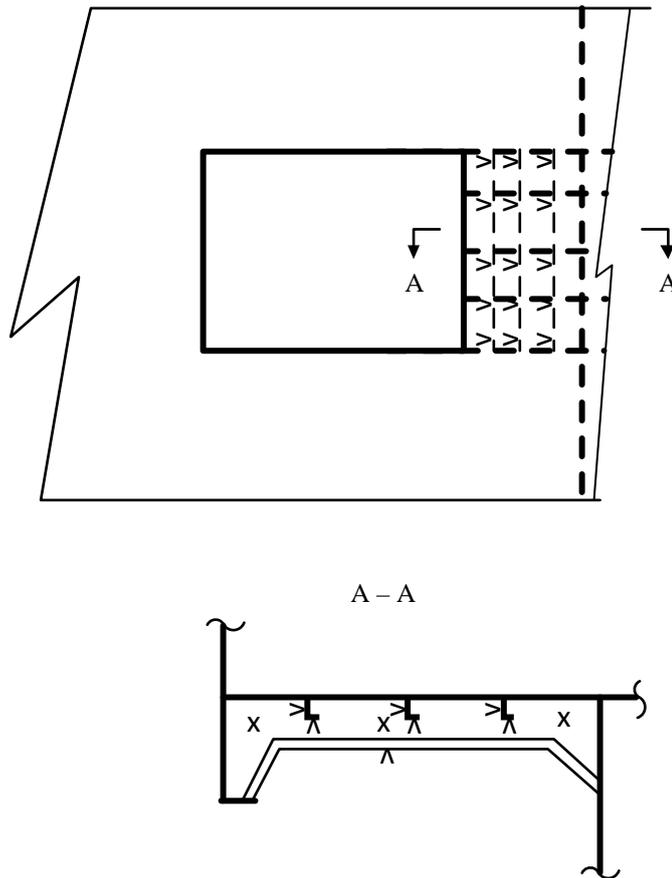

TABLE 1
Interpretations of Rule Requirements for the Locations and Number of Points to be Measured for CSR Bulk Carriers (Single Skin) (1 July 2013)

<i>Item</i>	<i>Interpretation</i>	<i>Figure Reference</i>
Selected plates on deck, tank top, bottom, double bottom and wind-and-water area	<Selected> means at least a single point on one out of three plates, to be chosen on representative areas of average corrosion.	
All deck, tank top and bottom plates and wind-and-water strakes	At least two points on each plate to be taken either at each 1/4 extremity of plate or at representative areas of average corrosion.	
Transverse section	A transverse section includes all longitudinal members such as plating, longitudinals and girders at the deck, side, bottom; inner bottom and hopper side plating, longitudinal bulkhead and bottom plating in top wing tanks.	7-A-6/Figure 5
All cargo hold hatch covers and coamings	Including plates and stiffeners	Locations of points are given in 7-A-6/Figure 6.
Transverse section of deck plating outside line of cargo hatch openings	Two single points on each deck plate (to be taken either at each 1/4 extremity of plate or at representative areas of average corrosion) between the ship sides and hatch coamings in the transverse section concerned	
All deck plating and underdeck structure inside line of hatch openings between cargo hold hatches	<All deck plating> means at least two points on each plate to be taken either at each 1/4 extremity of plate or at representative areas of average corrosion. "Under deck structure": at each short longitudinal girder: three points for web plating (fwd/middle/aft), single point for face plate, one point for web plating and one point for face plating of transverse beam in way. At each ends of transverse beams, one point for web plating and one point for face plating	Extent of areas is shown in 7-A-6/Figure 1. Location of points are given in 7-A-6/Figure 10.
Selected side shell frames in cargo holds	Includes side shell frame, upper and lower end attachments and adjacent shell plating. 25% of frames: one out of four frames should preferably be chosen throughout the cargo hold length on each side. 50% of frames: one out of two frames should preferably be chosen throughout the cargo hold length on each side. <Selected frames> means at least 3 frames on each side of cargo holds.	Extent of areas is shown in 7-A-6/Figure 1. Locations of points are given in 7-A-6/Figure 7.
Transverse bulkheads in cargo holds	Includes bulkhead plating, stiffeners and girders, including internal structure of upper and lower stools, where fitted. Two selected bulkheads: one is to be the bulkhead between the two foremost cargo holds and the second may be chosen in other positions.	Areas of measurements are shown in 7-A-6/Figure 1. Locations of points are given in 7-A-6/Figure 8.

TABLE 1 (continued)
Interpretations of Rule Requirements for the Locations and Number of Points to be Measured for CSR Bulk Carriers (Single Skin) (1 July 2013)

<i>Item</i>	<i>Interpretation</i>	<i>Figure Reference</i>
One transverse bulkhead in each cargo hold	This means that the close-up survey and related thickness measurements are to be performed on one side of the bulkhead; the side is to be chosen based on the outcome of the overall survey of both sides. In the event of doubt, the Surveyor may also require (possibly partial) close-up survey on the other side.	Areas of measurements are shown in 7-A-6/Figure 1. Locations of points are given in 7-A-6/Figure 8.
Transverse bulkheads in one topside, hopper and double bottom ballast tank	Includes bulkhead and stiffening systems. The ballast tank is to be chosen on the history of ballasting among those prone to have the most severe conditions.	Locations of points are given in 7-A-6/Figure 9.
Transverse webs in ballast tanks	Includes web plating, face plates, stiffeners and associated plating and longitudinals. One of the representative tanks of each type (i.e. topside of hopper or side tank) is to be chosen in the forward part.	Extent of areas is shown in 7-A-6/Figure 1. Locations of points are given in 7-A-6/Figure 7.

PART

7

APPENDIX

SECTION 7 Report on Thickness Measurement of Oil Carriers – Non Double Hull, Ore/Oil Ships – Non Double Hull and Chemical Carriers, etc.

1 Instructions

- 1.1** This document is to be used for recording thickness measurements, as required by the Enhanced Survey Program (see 7-3-2/5.13.5).
- 1.3** Reporting forms TM1-T, TM2-T, TM3-T, TM4-T, TM5-T and TM6-T are to be used for recording thickness measurements.
- 1.5** 7-A-7/Figures 1–5 are guidance diagrams and notes relating to the reporting forms and the procedure for thickness measurements of Oil Carriers, Ore/Oil Ships, etc.
- 1.7** 7-A-7/Figures 6–9 are guidance diagrams and notes relating to the reporting forms and the procedure for thickness measurements of Chemical Carriers.
- 1.9** The reporting forms should, where appropriate, be supplemented by data presented on structural sketches.

General Particulars

Ships name:-

IMO number

ABS identification number

Port of registry:-

Gross tons:-

Deadweight:-

Date of build:-

Classification society:-

Name of Company performing thickness measurement:-

Thickness measurement company certified by:-

Certificate No.

Certificate valid from _____ to _____

Place of measurement

First date of measurement:-

Last date of measurement:-

Special Periodical Survey/Intermediate Survey due:-*

Details of measurement equipment:-

Qualification of operator:-

Report Number:-

consisting of

Sheets

Name of operator:-

Name of surveyor:-

Signature of operator:-

Signature of surveyor:-

Company official stamp:-

Classification Society Official
Stamp:-

*Delete as appropriate.

Report on THICKNESS MEASUREMENT of ALL DECK PLATING, ALL BOTTOM SHELL PLATING or SIDE SHELL PLATING*
 (* delete as appropriate)

Ship's Name _____

Class Identity No. _____

Report No. _____

STRAKE POSITION	PLATE POSITION	No. or Letter	Org thk mm	Forward Reading				Aft Reading				Mean Diminution %		Max. Alwb. Dim. mm			
				Gauged		Diminution P		Diminution S		Gauged		Diminution P			Diminution S		
				P	S	mm	%	mm	%	P	S	mm	%		mm	%	
12th forward																	
11th																	
10th																	
9th																	
8th																	
7th																	
6th																	
5th																	
4th																	
3rd																	
2nd																	
1st																	
Amidships																	
1st aft																	
2nd																	
3rd																	
4th																	
5th																	
6th																	
7th																	
8th																	
9th																	
10th																	
11th																	
12th																	

Operators Signature _____

NOTES - See Reverse

NOTES

1. This report is to be used for recording the thickness measurement of:
 - 1.1 All strength deck plating within the cargo area.
 - 1.2 All keel, bottom shell plating and bilge plating within the cargo area.
 - 1.3 Side shell plating, including selected wind and water strakes outside 0.5L amidships.
2. The strake position is to be clearly indicated as follows:
 - 2.1 For strength deck, indicate the number of the strake of plating inboard from the stringer plate.
 - 2.2 For bottom plating, indicate the number of the strake of plating outboard from the keel plate.
 - 2.3 For side shell plating, give number of the strake of plating below sheerstrake and letter as shown on shell expansion.
3. For oil carriers, all deck plating strakes are to be recorded; for ore/oil ships, only the deck plating strakes outside line of openings are to be recorded.
4. Measurements are to be taken at the forward and aft areas of all plates, and where plates cross ballast/cargo tank boundaries, separate measurements for the area of plating in way of each type of tank are to be recorded.
5. The single measurements recorded are to represent the average of multiple measurements.
6. The maximum allowable diminution could be stated in an attached document.

Report on THICKNESS MEASUREMENT of SHELL AND DECK PLATING (one, two or three transverse sections)

Ship's Name _____

Class Identity No. _____

Report No. _____

STRENGTH DECK AND SHEERSTRAKE PLATING																											
STRAKE POSITION	FIRST TRANSVERSE SECTION AT FRAME NUMBER								SECOND TRANSVERSE SECTION AT FRAME NUMBER								THIRD TRANSVERSE SECTION AT FRAME NUMBER										
	No. or Ltr	Org Thk mm	Max Alwb Dim. mm	Gauged		Diminution P		Diminution S		No. or Ltr	Org Thk mm	Max Alwb Dim. mm	Gauged		Diminution P		Diminution S		No. or Ltr	Org Thk mm	Max Alwb Dim. mm	Gauged		Diminution P		Diminution S	
				P	S	mm	%	mm	%				P	S	mm	%	mm	%				P	S	mm	%	mm	%
Stringer Plate																											
1st strake Inboard																											
2nd																											
3rd																											
4th																											
5th																											
6th																											
7th																											
8th																											
9th																											
10th																											
11th																											
12th																											
13th																											
14th																											
centre strake																											
sheer strake																											
TOPSIDE TOTAL																											

Operators Signature _____

NOTES - See Reverse

NOTES

1. This report form is to be used for recording the thickness measurement of:
Strength deck plating and sheerstrake plating transverse sections:
One, two or three sections within the cargo area comprising the structural items (1), (2) and (3), as shown on the diagrams of typical transverse sections (See 7-A-7/Figures 1, 2 or 6).
2. For Oil Carriers, all deck plating strakes are to be recorded; and for Ore/Oil ships, only the deck plating strakes outside the line of openings are to be recorded.
3. The topside area comprises deck plating, stringer plate and sheerstrake (including rounded gunwales).
4. The exact frame station of measurement is to be stated.
5. The single measurements recorded are to represent the average of multiple measurements.
6. The maximum allowable diminution could be stated in an attached document.

Report on THICKNESS MEASUREMENT of SHELL AND DECK PLATING (one, two or three transverse sections)

Ship's Name _____

Class Identity No. _____

Report No. _____

SHELL PLATING																											
STRAKE POSITION	FIRST TRANSVERSE SECTION AT FRAME NUMBER								SECOND TRANSVERSE SECTION AT FRAME NUMBER								THIRD TRANSVERSE SECTION AT FRAME NUMBER										
	No. or Ltr	Org Thk mm	Max Alwb Dim. mm	Gauged		Diminution P		Diminution S		No. or Ltr	Org Thk mm	Max Alwb Dim. mm	Gauged		Diminution P		Diminution S		No. or Ltr	Org Thk mm	Max Alwb Dim. mm	Gauged		Diminution P		Diminution S	
				P	S	mm	%	mm	%				P	S	mm	%	mm	%				P	S	mm	%	mm	%
1st below sheer strake																											
2nd																											
3rd																											
4th																											
5th																											
6th																											
7th																											
8th																											
9th																											
10th																											
11th																											
12th																											
13th																											
14th																											
15th																											
16th																											
17th																											
18th																											
19th																											
20th																											
keel strake																											
BOTTOM TOTAL																											

Operators Signature _____

NOTES - See Reverse

NOTES

1. This report is to be used for recording the thickness measurements of:
Shell plating transverse sections:
One, two or three sections within the cargo area comprising the structural items (4), (5), (6) and (7), as shown on the diagrams of typical transverse sections (See 7-A-7/Figures 1, 2 or 6).
2. The bottom area comprises keel, bottom and bilge plating.
3. The exact frame station of measurement is to be stated.
4. The single measurements recorded are to represent the average of multiple measurements.
5. The maximum allowable diminution could be stated in an attached document.

Report on THICKNESS MEASUREMENT of LONGITUDINAL MEMBERS (one, two or three transverse sections)

Ship's Name _____

Class Identity No. _____

Report No. _____

STRUCTURAL MEMBER	FIRST TRANSVERSE SECTION AT FRAME NUMBER								SECOND TRANSVERSE SECTION AT FRAME NUMBER								THIRD TRANSVERSE SECTION AT FRAME NUMBER										
	Item No.	Org Thk	Max Alwb Dim.	Gauged		Diminution P		Diminution S		Item No.	Org Thk	Max Alwb Dim.	Gauged		Diminution P		Diminution S		Item No.	Org Thk	Max Alwb Dim.	Gauged		Diminution P		Diminution S	
		mm	mm	P	S	mm	%	mm	%		mm	mm	P	S	mm	%	mm	%		P	S	mm	%	mm	%		
		mm	mm								mm	mm										mm	mm				

Operators Signature _____

NOTES - See Reverse

NOTES

1. This report is to be used for recording the thickness measurement of:
Longitudinal Members at transverse sections:
One, two or three sections within the cargo area comprising the appropriate structural items (8) to (20), as shown on the diagrams of typical transverse sections (See 7-A-7/Figures 1, 2 or 6).
2. The exact frame station of measurement is to be stated.
3. The single measurements recorded are to represent the average of multiple measurements.
4. The maximum allowable diminution could be stated in an attached document.

TM4-T (1 July 2006)

Report on THICKNESS MEASUREMENT OF TRANSVERSE STRUCTURAL MEMBERS
In the cargo oil and water ballast tanks within the cargo tank length

Ship's Name _____ Class Identity No. _____ Report No. _____

TANK DESCRIPTION :									
LOCATION OF STRUCTURE :									
STRUCTURAL MEMBER	ITEM	Original Thickness mm	Maximum Allowable Diminution mm	Gauged		Diminution P		Diminution S	
				Port	Starboard	mm	%	mm	%

Operators Signature _____

NOTES - See Reverse

NOTES

1. This report is to be used for recording the thickness measurement of transverse structural members, comprising the appropriate structural items (25) to (33), as shown on diagrams of typical transverse section (See 7-A-7/Figures 1, 2 or 6).
2. Guidance for areas of measurement is indicated on 7-A-7/Figures 5 or 9.
3. The single measurements recorded are to represent the average of multiple measurements.
4. The maximum allowable diminution could be stated in an attached document.

Report on THICKNESS MEASUREMENT OF W.T./O.T. TRANSVERSE BULKHEADS
within the cargo tank or cargo hold spaces

TM5-T (1 July 2006)

Ship's Name _____ Class Identity No. _____ Report No. _____

TANK/HOLD DESCRIPTION :								
LOCATION OF STRUCTURE :					FRAME NO. :			
STRUCTURAL COMPONENT (PLATING/STIFFENER)	Original Thickness mm	Maximum Allowable Diminution mm	Gauged		Diminution P		Diminution S	
			Port	Starbd	mm	%	mm	%

Operators Signature _____

NOTES - See Reverse

NOTES

1. This report form is to be used for recording the thickness measurement of W.T./O.T. transverse bulkheads.
2. Guidance for areas of measurement is indicated on 7-A-7/Figures 5 or 9.
3. The single measurements recorded are to represent the average of multiple measurements.
4. The maximum allowable diminution could be stated in an attached document.

Report on THICKNESS MEASUREMENT OF MISCELLANEOUS STRUCTURAL MEMBERS

TM6-T (1 July 2006)

Ship's Name _____

Class Identity No. _____

Report No. _____

STRUCTURAL MEMBER :									SKETCH	
LOCATION OF STRUCTURE :										
Description	Org Thk. mm	Maximum Allowable Diminution mm	Gauged		Diminution P		Diminution S			
			P	S	mm	%	mm	%		

Operators Signature _____

NOTES - See Reverse

NOTES

1. This report is to be used for recording the thickness measurement of miscellaneous structural members including the structural items (36), (37) and (38).
2. The single measurements recorded are to represent the average of multiple measurements.
3. The maximum allowable diminution could be stated in an attached document.

FIGURE 1
Thickness Measurement – Oil Carriers, Ore/Oil Ships, etc.
Oil Carrier – Typical transverse section indicating longitudinal and transverse members

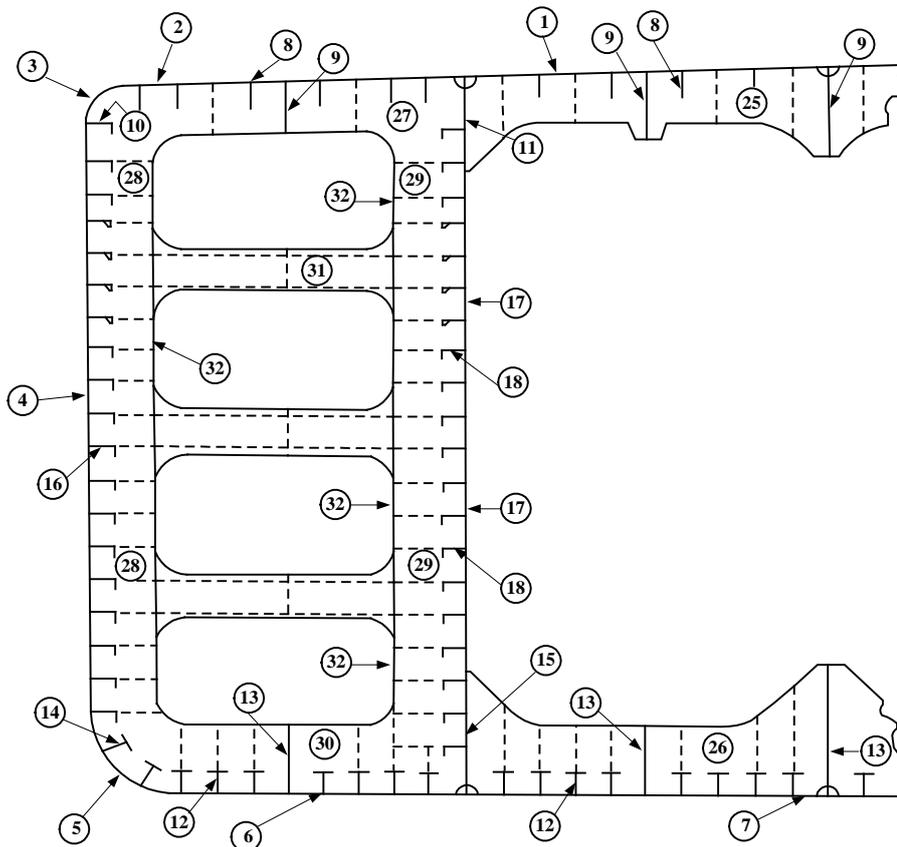

REPORT ON TM2-T (I) & (ii)	
1.	Strength deck plating
2.	Stringer plate
3.	Sheerstrake
4.	Side shell plating
5.	Bilge plating
6.	Bottom shell plating
7.	Keel plate

REPORT ON TW6-T	
36.	Hatch coamings
37.	Deck plating between hatches
38.	Hatch covers
39.	
40.	

REPORT ON TM3-T	
8.	Deck longitudinals
9.	Deck girders
10.	Sheerstrake longitudinals
11.	Longitudinals bulkhead top strake
12.	Bottom Longitudinals
13.	Bottom girders
14.	Bilge longitudinals
15.	Longitudinals bulkhead lower strake
16.	Side shell longitudinals
17.	Longitudinal bulkhead plating (remainder)
18.	Longitudinal bulkhead longitudinals
19.	Inner bottom plating
20.	Inner bottom longitudinals
21.	
22.	
23.	
24.	

REPORT ON TM4-T	
25.	Deck transverse center tank
26.	Bottom transverse center tank
27.	Deck transverse wing tank
28.	Side shell vertical web
29.	Longitudinal bulkhead vertical web
30.	Bottom transverse wing tank
31.	Struts
32.	Transverse web face plate
33.	D.B. Floors
34.	
35.	

FIGURE 2
Thickness Measurement – Oil Carriers, Ore/Oil Ships, etc.

Ore/Oil Ship – Typical transverse section indicating longitudinal and transverse members

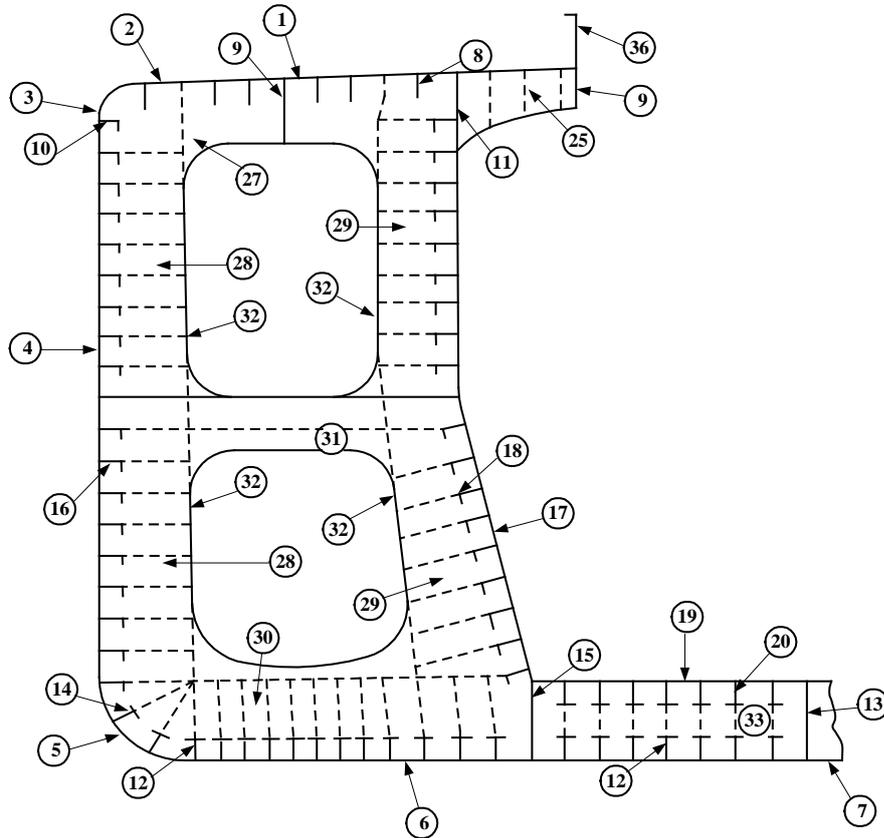

REPORT ON TM2-T (i) & (ii)	
1.	Strength deck plating
2.	Stringer plate
3.	Sheerstrake
4.	Side shell plating
5.	Bilge plating
6.	Bottom shell plating
7.	Keel plate

REPORT ON TW6-T	
36.	Hatch coamings
37.	Deck plating between hatches
38.	Hatch covers
39.	
40.	

REPORT ON TM3-T	
8.	Deck longitudinals
9.	Deck girders
10.	Sheerstrake longitudinals
11.	Longitudinals bulkhead top strake
12.	Bottom Longitudinals
13.	Bottom girders
14.	Bilge longitudinals
15.	Longitudinals bulkhead lower strake
16.	Side shell longitudinals
17.	Longitudinal bulkhead plating (remainder)
18.	Longitudinal bulkhead longitudinals
19.	Inner bottom plating
20.	Inner bottom longitudinals
21.	
22.	
23.	
24.	

REPORT ON TM4-T	
25.	Deck transverse center tank
26.	Bottom transverse center tank
27.	Deck transverse wing tank
28.	Side shell vertical web
29.	Longitudinal bulkhead vertical web
30.	Bottom transverse wing tank
31.	Struts
32.	Transverse web face plate
33.	D.B. Floors
34.	
35.	

FIGURE 3
Thickness Measurement – Oil Carriers, Ore/Oil Ships, etc.

Transverse section outline to be used for longitudinal and transverse members where typical Oil Carrier or Oil/Ore ship sections are not applicable

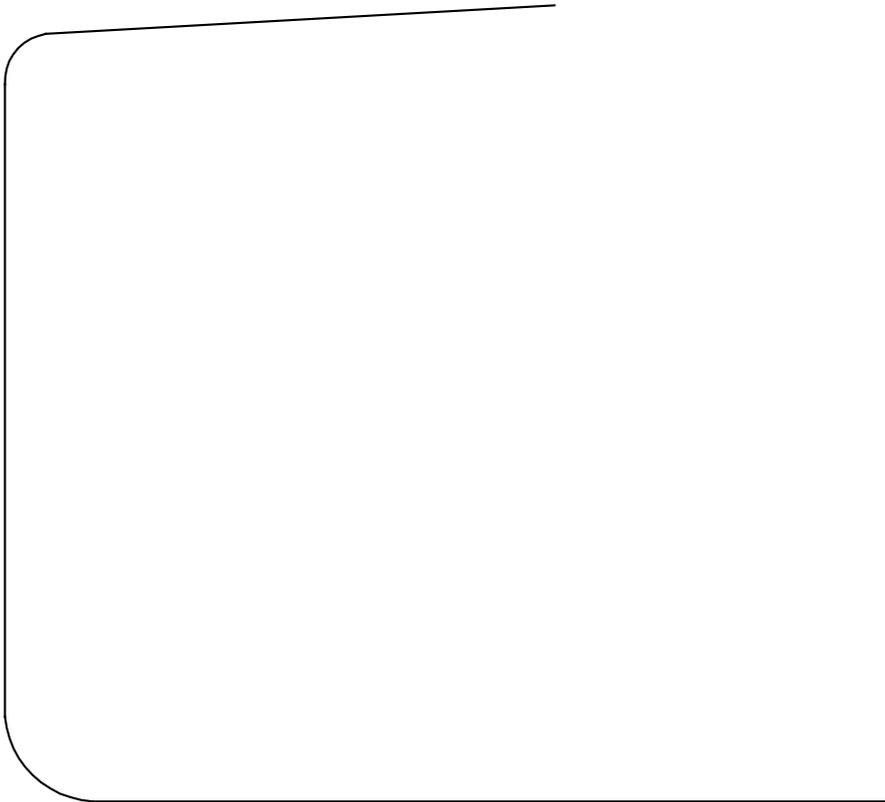

REPORT ON TM2-T (i) & (ii)
1. Strength deck plating
2. Stringer plate
3. Sheerstrake
4. Side shell plating
5. Bilge plating
6. Bottom shell plating
7. Keel plate

REPORT ON TW6-T
36. Hatch coamings
37. Deck plating between hatches
38. Hatch covers
39.
40.

REPORT ON TM3-T
8. Deck longitudinals
9. Deck girders
10. Sheerstrake longitudinals
11. Longitudinals bulkhead top strake
12. Bottom Longitudinals
13. Bottom girders
14. Bilge longitudinals
15. Longitudinals bulkhead lower strake
16. Side shell longitudinals
17. Longitudinal bulkhead plating (remainder)
18. Longitudinal bulkhead longitudinals
19. Inner bottom plating
20. Inner bottom longitudinals
21.
22.
23.
24.

REPORT ON TM4-T
25. Deck transverse center tank
26. Bottom transverse center tank
27. Deck transverse wing tank
28. Side shell vertical web
29. Longitudinal bulkhead vertical web
30. Bottom transverse wing tank
31. Struts
32. Transverse web face plate
33. D.B. Floors
34.
35.

FIGURE 4
Thickness Measurement – Oil Carriers, Ore/Oil Ships, etc.
Typical transverse sections showing all longitudinal members to be reported on TM2-T and TM3-T

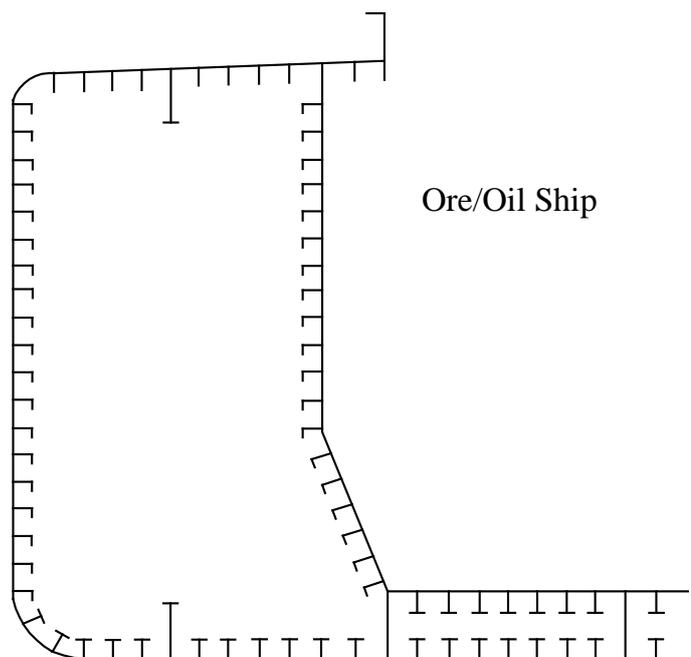
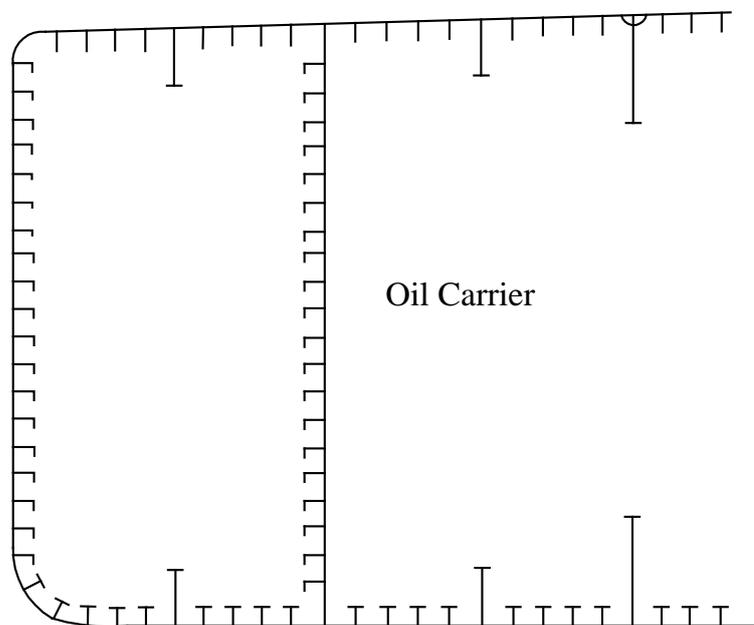

FIGURE 5
Thickness Measurement – Oil Carriers, Ore/Oil Ships, etc.
Close-up Survey Requirements

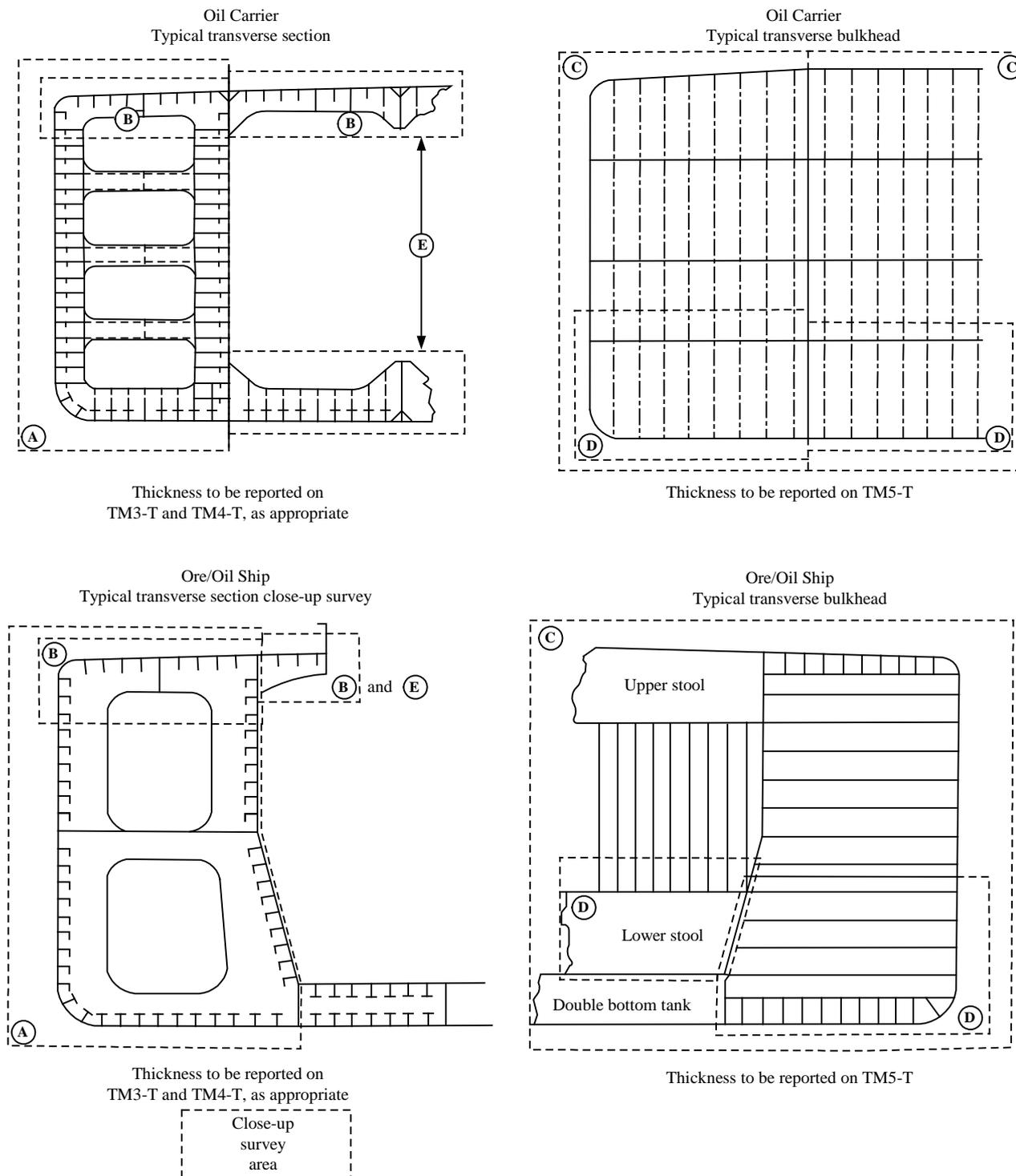
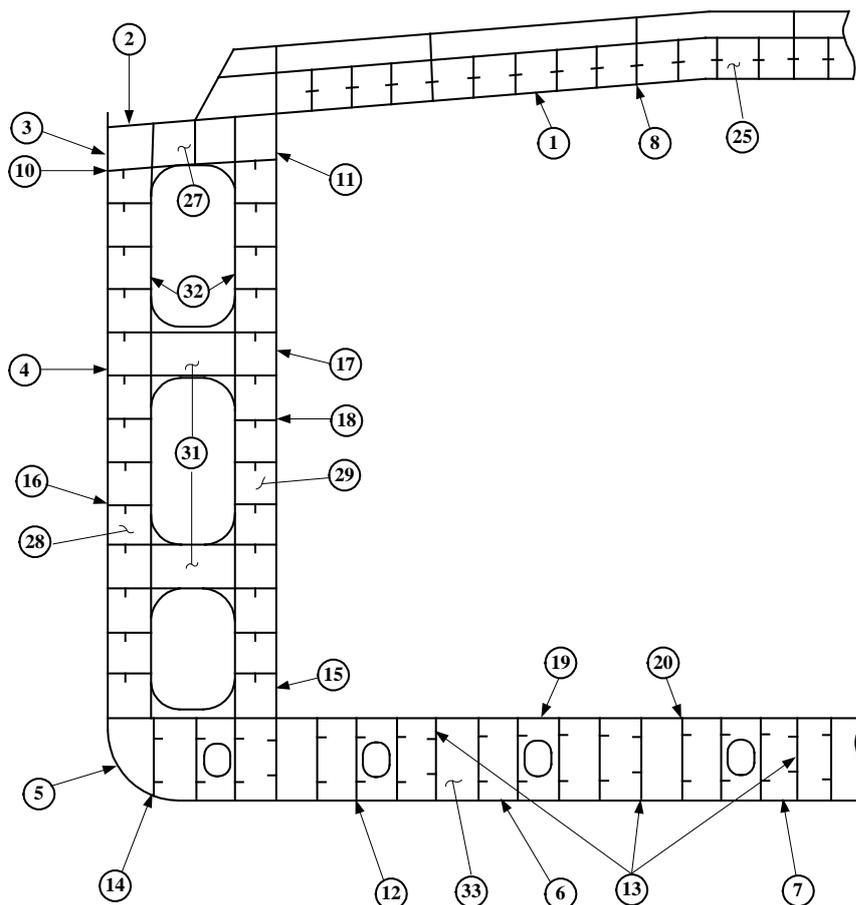

FIGURE 6
Thickness Measurement – Chemical Carriers



REPORT ON TM2-T (i) & (ii)
1. Strength deck plating
2. Stringer plate
3. Sheerstrake
4. Side shell plating
5. Bilge plating
6. Bottom shell plating
7. Keel plate

REPORT ON TW6-T
36. Hatch coamings
37. Deck plating between hatches
38. Hatch covers

REPORT ON TM3-T
8. Deck longitudinals
9. Deck girders
10. Sheerstrake longitudinals
11. Longitudinals bulkhead top strake
12. Bottom Longitudinals
13. Bottom girders
14. Bilge longitudinals
15. Longitudinals bulkhead lower strake
16. Side shell longitudinals
17. Longitudinal bulkhead plating (remainder)
18. Longitudinal bulkhead longitudinals
19. Inner bottom plating
20. Inner bottom longitudinals
21.
22.
23.
24.

REPORT ON TM4-T
25. Deck transverse center tank
26. Bottom transverse center tank
27. Deck transverse wing tank
28. Side shell vertical web
29. Longitudinal bulkhead vertical web
30. Bottom transverse wing tank
31. Struts
32. Transverse web face plate
33. D.B. Floors
34.
35.

FIGURE 7
Thickness Measurement – Chemical Carriers

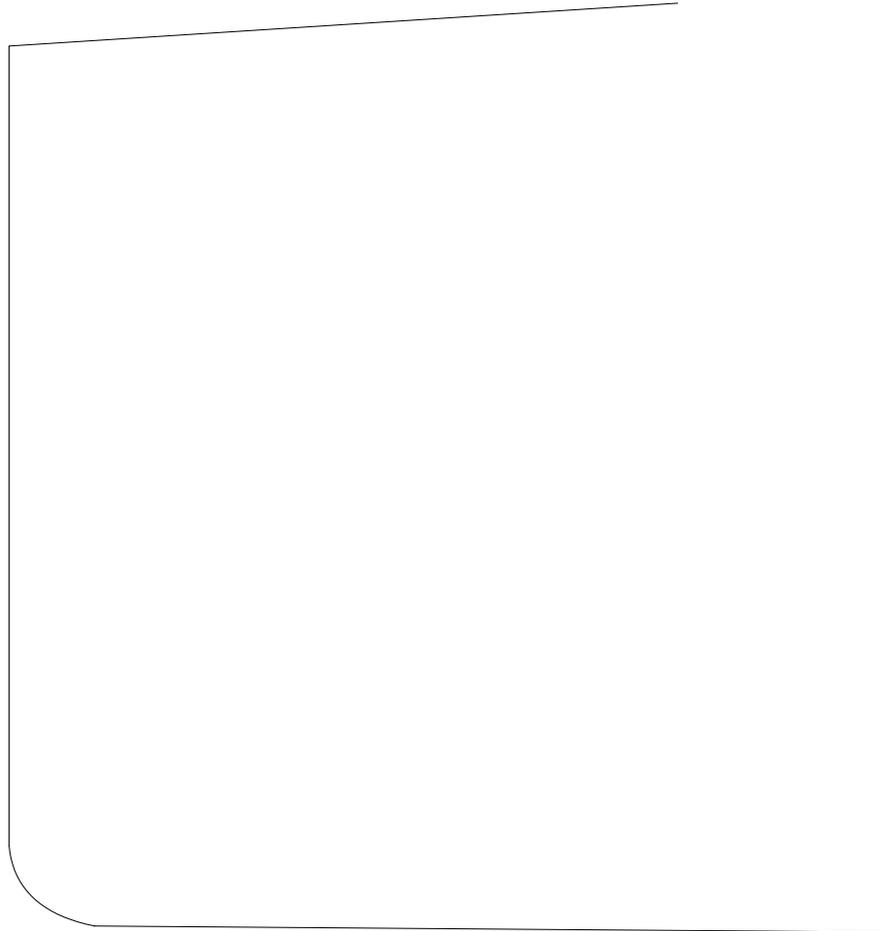

REPORT ON TM2-T (i) & (ii)	
1.	Strength deck plating
2.	Stringer plate
3.	Sheerstrake
4.	Side shell plating
5.	Bilge plating
6.	Bottom shell plating
7.	Keel plate

REPORT ON TW6-T	
36.	Hatch coamings
37.	Deck plating between hatches
38.	Hatch covers

REPORT ON TM3-T	
8.	Deck longitudinals
9.	Deck girders
10.	Sheerstrake longitudinals
11.	Longitudinals bulkhead top strake
12.	Bottom Longitudinals
13.	Bottom girders
14.	Bilge longitudinals
15.	Longitudinals bulkhead lower strake
16.	Side shell longitudinals
17.	Longitudinal bulkhead plating (remainder)
18.	Longitudinal bulkhead longitudinals
19.	Inner bottom plating
20.	Inner bottom longitudinals
21.	
22.	
23.	
24.	

REPORT ON TM4-T	
25.	Deck transverse center tank
26.	Bottom transverse center tank
27.	Deck transverse wing tank
28.	Side shell vertical web
29.	Longitudinal bulkhead vertical web
30.	Bottom transverse wing tank
31.	Struts
32.	Transverse web face plate
33.	D.B. Floors
34.	
35.	

FIGURE 8
Thickness Measurement – Chemical Carriers

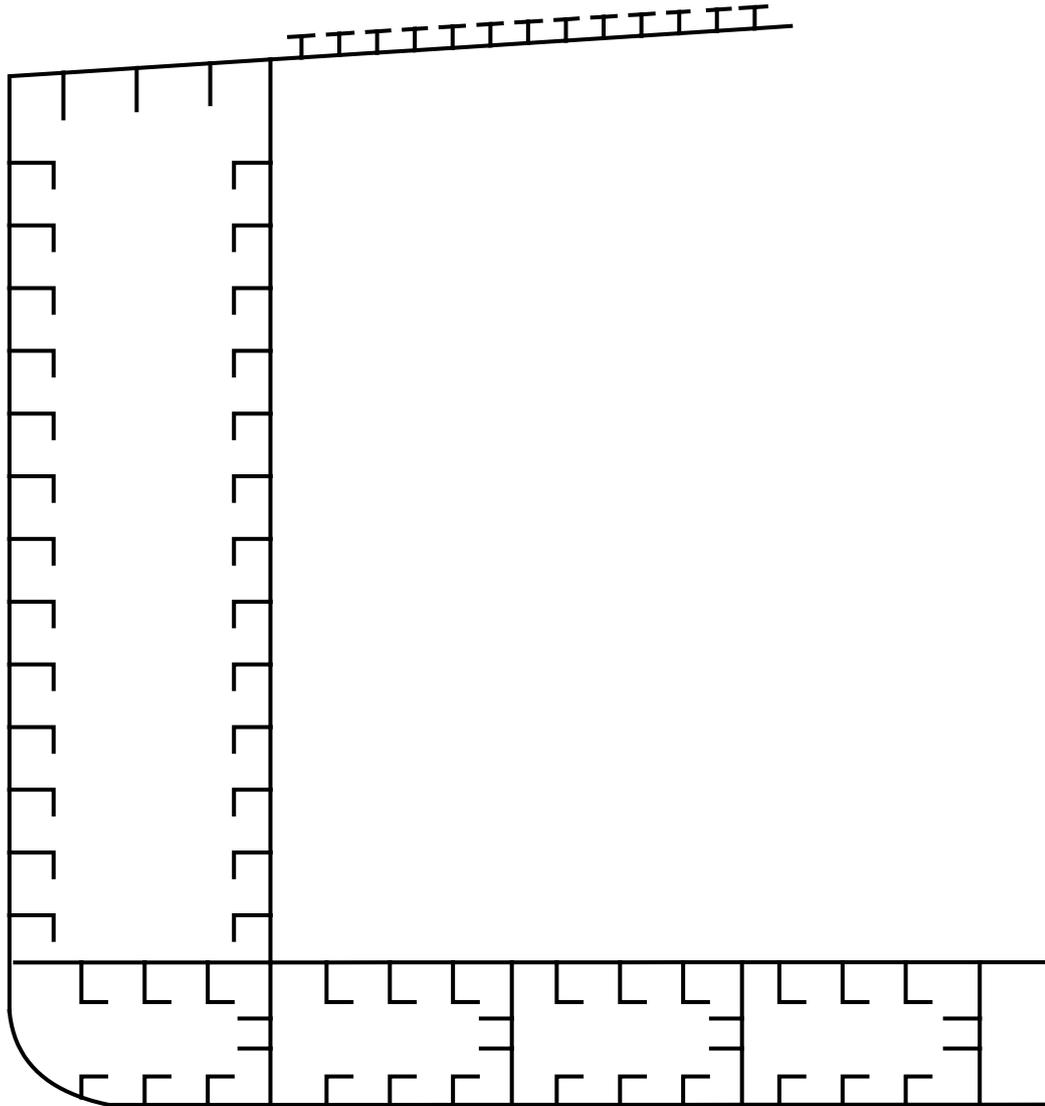

FIGURE 9
Thickness Measurement – Chemical Carriers

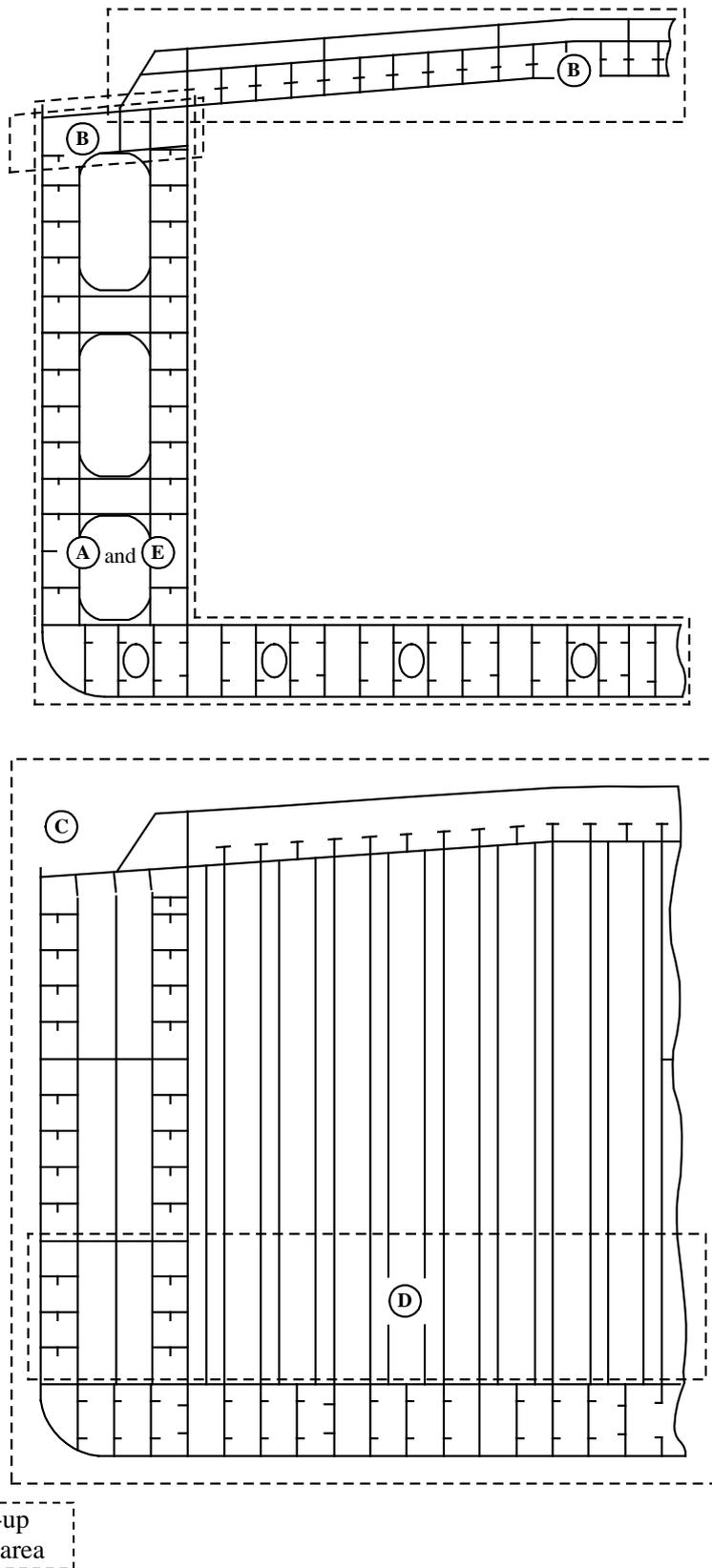

FIGURE 10
Representative Transverse Section of Chemical Tanker
Areas A & B and 1 & 2 (1 July 2013)

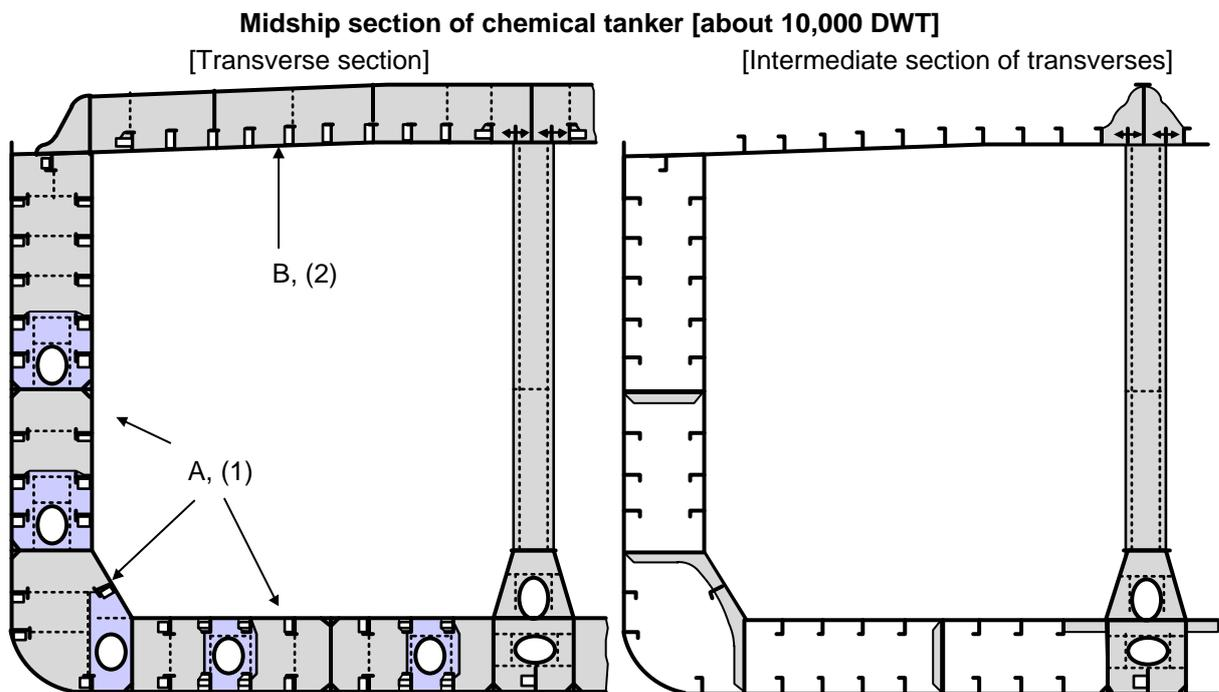

FIGURE 11
Representative Transverse Section of Chemical Tanker
Areas C & D and 3, 4 and 5 (1 July 2013)

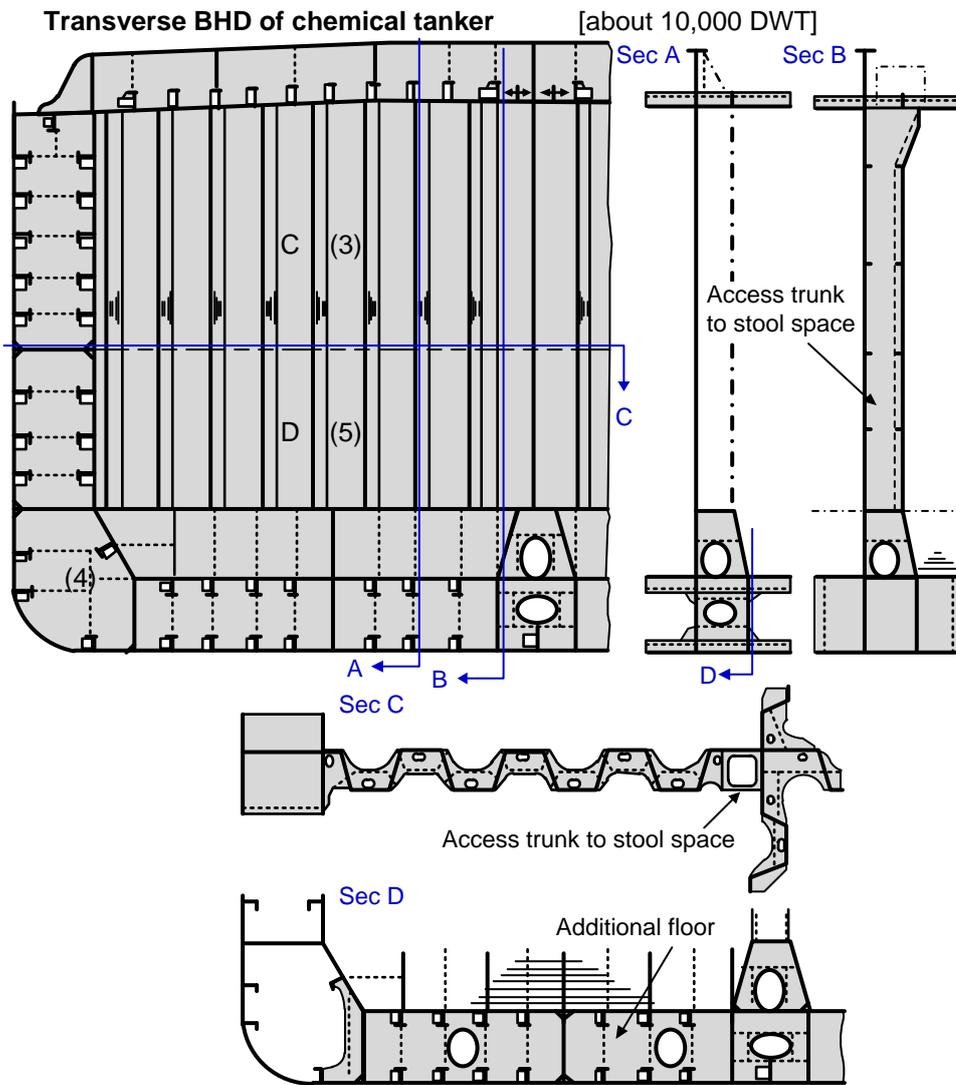
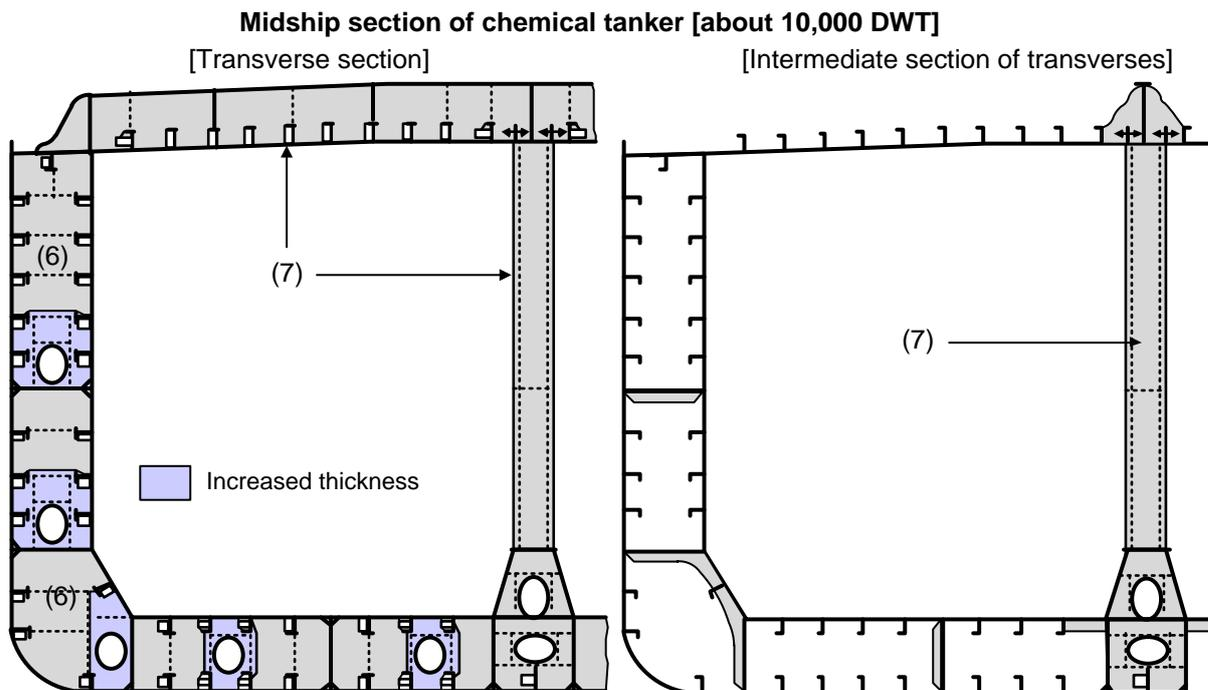

FIGURE 12
Representative Transverse Section of Chemical Tanker Areas 6 and 7 (1 July 2013)



PART

7

APPENDIX

SECTION 8 Intermediate and Special Periodical Survey Preparation for ESP and ESDC Vessels

- 1 Sample Survey Plan for Intermediate and Special Periodical Surveys
for ESDC Vessels (*1 July 2008*)

SPECIAL PERIODICAL SURVEY PLAN

1. VESSEL PARTICULARS

Name:

ABS ID:

Type of Ship:

Date of Build:

Special Periodical Survey No:

Due Date of Special Periodical Survey:

Due Date of Drydocking Survey:

2. GENERAL

1. Where and when will the Special Periodical Survey be held?
2. Where and when will the Drydocking Survey be held?
3. Where and when will the Close-up Survey and Thickness Measurement be carried out?
4. Name and address of the Thickness Measurement firm.
5. How will access be provided for the Close-up Survey and Thickness Measurement?
6. If rafting is used as a means of access, what means will be provided for the survey of the upper reaches of the tanks?
7. Has the vessel's onboard **ESDC** documentation, including survey reports and previous repair history, been reviewed to determine damage experience related to the vessel? State any areas identified which require consideration for survey.

3. CLOSE-UP SURVEYS

Note: The minimum requirements for Close-up Survey are given in 7-3-2/5.15.4 or 7-3-2/3.9.3 for General Dry Cargo Vessels.

Proposed locations and extent of Close-up Survey are as follows:

(Owner to list proposed location and extent of Close-up Survey.)

4. THICKNESS MEASUREMENTS

Note: The minimum requirements for Thickness Measurements are given in 7-3-2/5.15.5 or 7-3-2/3.9.4 for General Dry Cargo Vessels.

Proposed locations and extent of Thickness Measurements are as follows:

(Owner to list proposed location and extent of Thickness Measurements.)

5. TANK TESTING

Note: The minimum requirements for Tank Testing are given in 7-3-2/5.15.6 for General Dry Cargo Vessels, and in 7-3-2/3.1.4 for all vessels.

Proposed schedule for Tank Testing.

(Owner to list proposed selection for Tank Testing.)

6. TANK/HOLD PARTICULARS

Note: Alternatively, an A4 size general arrangement or similar showing tank/hold arrangements and usage may be submitted.

The following table should provide details of all of the tanks in the cargo length and all ballast tanks outside of the cargo length, their content type, method of corrosion protection and condition of any coating in the tank.

TANK/HOLD	TANK/HOLD TYPE	CORROSION PROTECTION	COATING CONDITION

Notations:

Tank Type: **SBT** = segregated ballast tank, **C.O.** = cargo oil, **WBT** = water ballast tank, **SP** = slop tank.

Protection: **C** = hard coating, **SC** = soft coating, **A** = anodes, **NP** = no protection

GOOD: condition with only minor spot rusting

FAIR: condition with local breakdown at edges of stiffeners and weld connections and/or light rusting over 20% or more of areas under consideration, but less than as defined for POOR condition.

POOR: condition with general breakdown of coating over 20% or more of areas or hard scale at 10% or more of areas under consideration.

3 Guidelines for Technical Assessment in Conjunction with Planning for Enhanced Surveys

3.1 Introduction

These guidelines contain information and suggestions concerning technical assessments which may be of use in conjunction with the planning of Enhanced Surveys. These guidelines are a recommended tool which may be made mandatory by ABS, when considered necessary and appropriate, in conjunction with the preparation of the required Survey Plan.

3.3 Purpose and Principles

3.3.1 Purpose

The purpose of the technical assessments described in these guidelines is to assist in identifying critical structural areas, nominating suspect areas and in focusing attention on structural elements or areas of structural elements which may be particularly susceptible to, or evidence a history of, wastage or damage. This information may be useful in nominating locations, areas and tanks for thickness measurement, close-up survey and tank testing.

Critical Structural Areas are locations which have been identified from calculations to require monitoring or from the service history of the subject ship or from similar or sister ships (if available) to be sensitive to cracking, buckling or corrosion which would impair the structural integrity of the ship.

3.3.2 Minimum Requirements

However, these guidelines may not be used to reduce the requirements pertaining to Close-up Survey, Thickness Measurement and Tank Testing.

3.3.3 Timing

As with other aspects of survey planning, the technical assessments described in these guidelines should be worked out by the Owner or operator in cooperation with the Classification Society well in advance of the commencement of the Special Periodical Survey, i.e., prior to commencing the survey and normally at least 12 to 15 months before the survey's completion due date.

3.3.4 Aspects to be Considered

Technical assessments, which may include quantitative or qualitative evaluation of relative risks of possible deterioration, of the following aspects of a particular ship may be used as a basis for the nomination of tanks and areas for survey:

- Design features such as stress levels on various structural elements, design details and extent of use of high tensile steel.
- History with respect to corrosion, cracking, buckling, indents and repairs for the particular ship as well as similar vessels, where available.
- Information with respect to types of cargo carried, use of different tanks for cargo/ballast, protection of tanks and conditions of coating, if any.

Technical assessments of the relative risks of susceptibility to damages or deterioration of various structural elements and areas should be judged and decided on the basis of recognized principles and practices, such as may be found in TSCF publications "Guidance Manual for the Inspection and Condition Assessment of Tanker Structures" and "Condition Evaluation and Maintenance of Tanker Structures" for Tankers, IACS publication "Bulk Carriers: Guidelines for Surveys, Assessment and Repair of Hull Structures" for Bulk Carriers.

3.5 Technical Assessment

3.5.1 General

There are three basic types of possible failure which may be the subject of technical assessment in connection with planning of surveys: corrosion, cracks and buckling. Contact damages are not normally covered by the survey plan since indentations are usually noted in survey reports and assumed to be dealt with as a normal routine by Surveyors.

Technical assessments performed in conjunction with the survey planning process should, in principle, be carried out as shown schematically in 7-A-8/Figure 1. The approach is basically an evaluation of the risk based on knowledge and experience related to design and corrosion.

The design should be considered with respect to structural details which may be susceptible to buckling or cracking as a result of vibration, high stress levels or fatigue.

Corrosion is related to the aging process, and is closely connected with the quality of corrosion protection of new building, and subsequent maintenance during the service life. Corrosion may also lead to cracking and/or buckling.

3.5.2 Methods

3.5.2(a) Design Details. Damage experience related to the ship in question and similar ships, where available, is the main source of information to be used in the process of planning. In addition, a selection of structural details from the design drawings should be included.

Typical damage experience to be considered will consist of:

- Number, extent, location and frequency of cracks
- Location of buckles

This information may be found in the survey reports and/or the Owner's files, including the results of the Owner's own inspections. The defects should be analyzed, noted and marked on sketches.

In addition, general experience should be utilized. For example, 7-A-8/Figure 2 shows typical locations in Bulk Carriers which experience has shown may be susceptible to structural damage. Also, reference should be made to TSCF publication "Guidance Manual for the inspection and Condition Assessment of Tanker Structures" for Tankers and IACS publication "Bulk Carriers: Guidelines for Survey, Assessment and Repair" for Bulk Carriers which contains a catalogue of typical damages and proposed repair methods for various hull structural details.

Such figures should be used together with a review of the main drawings in order to compare with the actual structure and search for similar details which may be susceptible to damage. An example for Bulk Carriers is shown in 7-A-8/Figure 3 and for Tankers is shown in 7-A-8/Figure 4.

The review of the main structural drawings should include checking for typical design details where cracking has been experienced. The factors contributing to damage should be carefully considered.

The use of high tensile steel (HTS) is an important factor. Details showing good service experience where ordinary, mild steel has been used may be more susceptible to damage when HTS, and its higher associated stresses, is utilized. There is extensive and, in general, good experience with the use of HTS for longitudinal material in deck and bottom structures. Experience in other locations, where dynamic stresses may be higher, is less favorable, e.g., side structures.

In this respect, stress calculations of typical and important components and details, in accordance with the latest Rules or other relevant methods, may prove useful and should be considered.

The selected areas of the structure identified during this process should be recorded and marked on the structural drawings to be included in the Survey Plan.

3.5.2(b) *Corrosion (1 July 2006)*. In order to evaluate relative corrosion risks, the following information is generally to be considered.

- Usage of Tanks and Spaces
- Condition of Coatings
- Cleaning Procedures
- Previous Corrosion Damage
- Corrosion Risk Scheme (TSCF publication, “Condition Evaluation and Maintenance of Tanker Structures” Table 3.1)
- Location of Heated Tanks

TSCF publication, “Condition Evaluation and Maintenance of Tanker Structures” gives definitive examples which can be used for judging and describing coating condition, using typical pictures of conditions.

The evaluation of corrosion risks should be based on information in TSCF publication, “Condition Evaluation and Maintenance of Tanker Structures” for Tankers and IACS publication, “Bulk Carriers: Guidelines for Surveys, Assessment and Repair of Hull Structures” for Bulk Carriers, together with relevant information on the age of the ship and the anticipated condition of the ship as derived from the information collected in order to prepare the Survey Plan.

The various tanks and spaces should be listed with the corrosion risks nominated accordingly.

3.5.2(c) *Locations for Close-up Survey and Thickness Measurement*. On the basis of the table of corrosion risks and the evaluation of design experience, the locations for initial close-up survey and thickness measurement (sections) may be nominated.

The sections subject to thickness measurement should normally be nominated in tanks and spaces where corrosion risk is judged to be the highest.

The selection of tanks and spaces for close-up survey should, initially, be based on highest corrosion risk, and should always include ballast tanks. The principle for the selection should be that the extent is increased by age or where information is insufficient or unreliable.

3.7 References

3.7.1

IACS Unified Requirements Z10.1 “Hull Surveys of Oil Tankers”, Z10.2 “Hull Surveys of Bulk Carriers”, Z10.3 “Hull Surveys of Chemical Tankers”, Z10.4 “Hull Surveys of Double Hull Oil Tankers”.

3.7.2

TSCF, “Guidance Manual for the Inspection and Condition Assessment of Tanker Structures.”

3.7.3

TSCF, “Condition Evaluation and Maintenance of Tanker Structures.”

3.7.4

IACS, “Bulk Carriers: Guidelines for Surveys, Assessment and Repair of Hull Structures.”

FIGURE 1
Technical Assessment and the Survey Planning Process (1 July 2006)

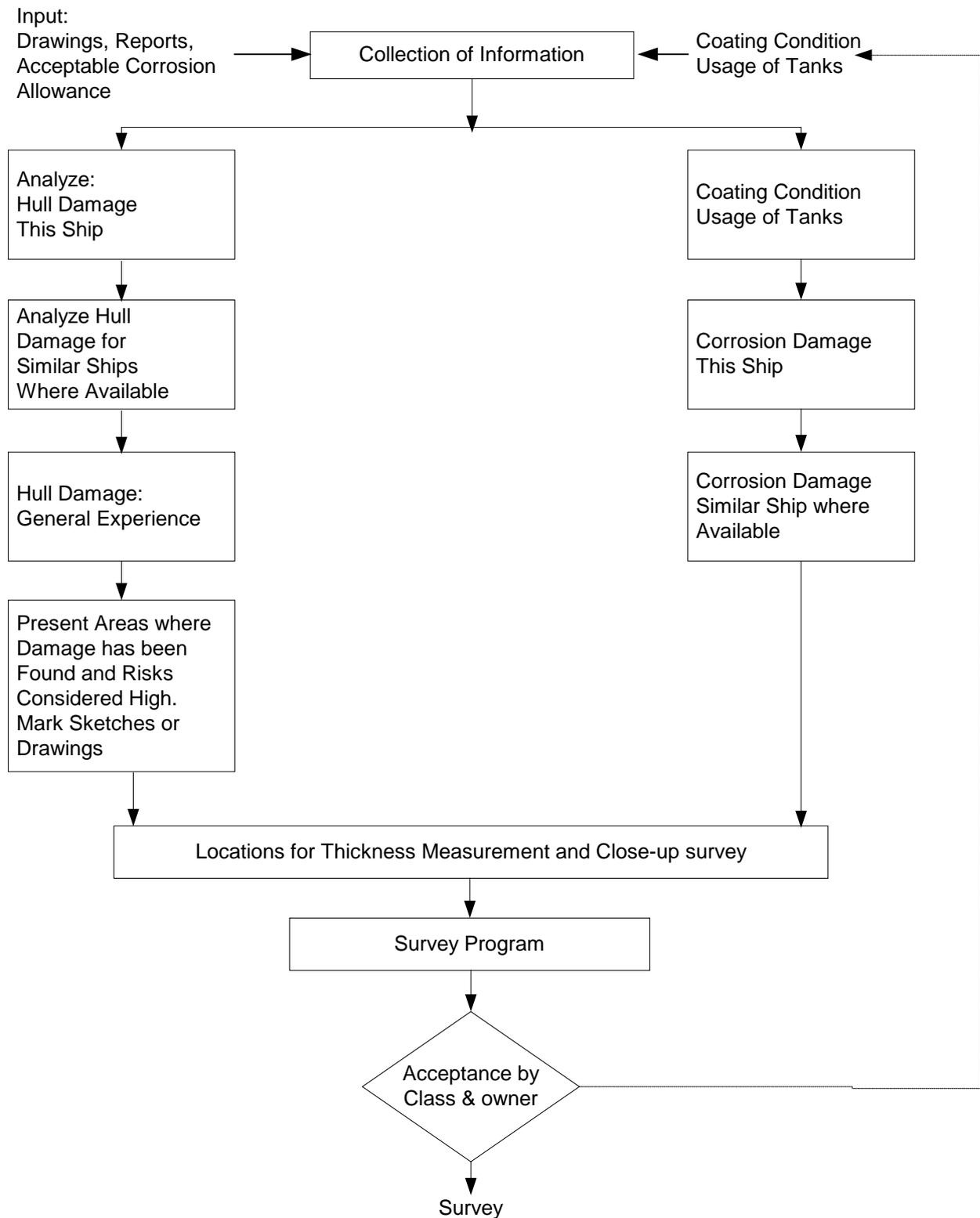

FIGURE 2
Typical Locations Susceptible to Structural Damage or Corrosion

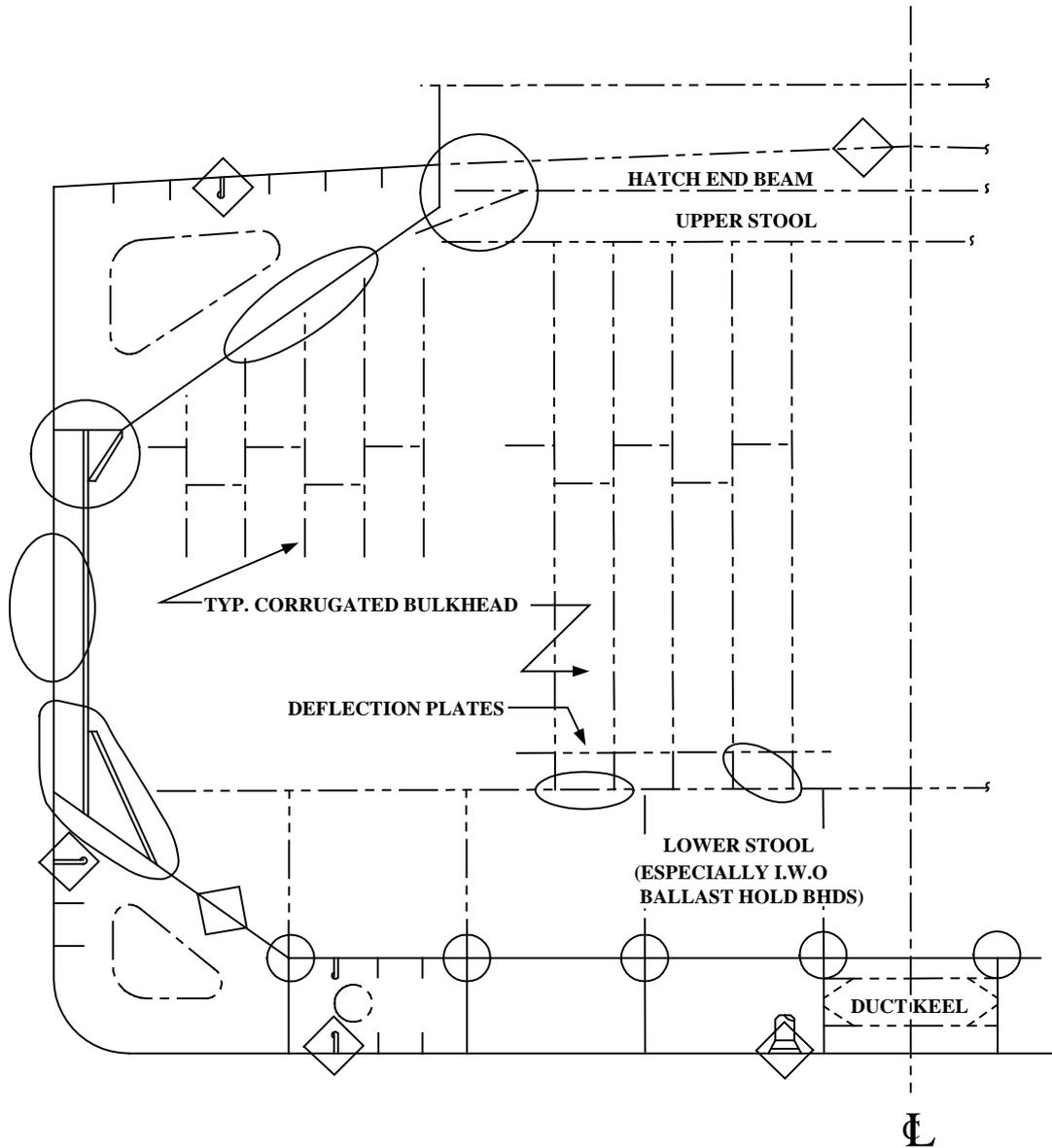

FIGURE 3 Typical Damage and Repair Example

(Reproduced From IACS, "Bulk Carriers: Guidelines for Survey, Assessment and Repair")

AREA 1	STRUCTURAL ITEM	SIDE SHELL FRAMES AND END BRACKETS (SEPARATE BRACKET CONFIGURATION)	EXAMPLE 1
DETAIL OF DAMAGE		FRACTURES ON BRACKETS AT TERMINATION OF FRAME	
SKETCH OF DAMAGE		SKETCH OF REPAIR	
 <p style="text-align: center;">SEPARATE BRACKET CONFIGURATION</p>		 <p style="text-align: center;">S = SNIPED END</p>	
NOTES ON POSSIBLE CAUSE OF DAMAGE/REPAIR			
<ol style="list-style-type: none"> 1. This type of damage is due to stress concentration. 2. For small fractures, e.g., hairline fractures, the fracture can be "veed" out, welded up, ground and examined by NDT for fractures. 3. For larger/significant fractures, consideration is to be given to cropping and partly renewing/renewing the frame brackets. If renewing the brackets, ends of frames can be sniped to soften them. 4. If left prudent, soft toes are to be incorporated at the boundaries of the bracket and the wing tanks. 5. Attention is to be given to the structure in wing tanks in way of the extended bracket arm. i.e., reinforcement provided in line with the bracket arm. 			

FIGURE 4 Typical Damage and Repair Example

(Reproduced From TSCF "Guidance Manual for the Inspection and Condition Assessment of Tanker Structures")

LOCATION EXAMPLE No. 1	Connection of longitudinals to transverse webs Web and flat bar fractures at cut-outs for longitudinal stiffener connections	
TYPICAL DAMAGE	PROPOSED REPAIR	
 <p style="text-align: center;">VIEW A - A</p> <p style="text-align: center;">SIDE SHELL OR BULKHEAD LONGITUDINAL WEB PLATING * FRACTURE WEB FLAT BAR STIFFENER</p> <p>NOTE:* ONE OR MORE FRACTURES MAY OCCUR</p>	<p style="text-align: center;">FULL COLLAR IF FRACTURES IN WEB PLATE ARE SMALL AND ARE REPAIRED BY WELDING</p>  <p style="text-align: center;">VIEW A - A</p> <p style="text-align: center;">WEB AND FLAT BAR CROPPED AND PART RENEWED OR ALTERNATIVELY WELDED</p>	
Factors Contributing to Damage		
<ol style="list-style-type: none"> 1. Asymmetrical connection of flat bar stiffener resulting in high peak stresses at the heel of the stiffener under fatigue loading. 2. Insufficient area of connection of longitudinal to web plate. 3. Defective weld at return around the plate thickness. 4. High localized corrosion at areas of stress concentration such as flat bar stiffener connections, corners of cut-out for the longitudinal and connection of web to shell at cut-outs. 5. High shear stress in the web of the transverse. 6. Dynamic sea way loads/ship motions. 		
FIGURE 1	TANKER STRUCTURE CO-OPERATIVE FORUM SUBJECT: CATALOG OF STRUCTURAL DETAILS	FIGURE 1

5 Owners Inspection Report

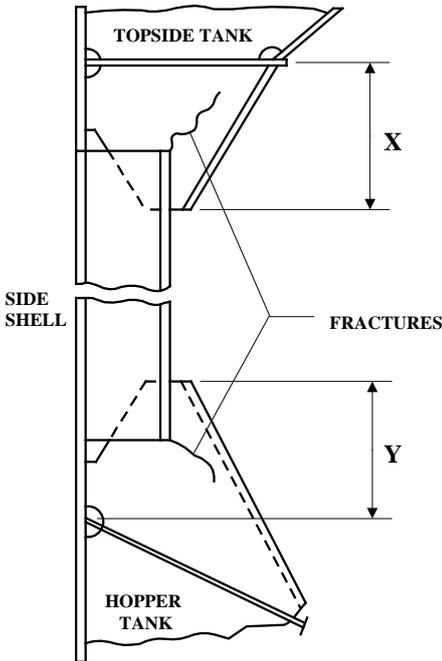
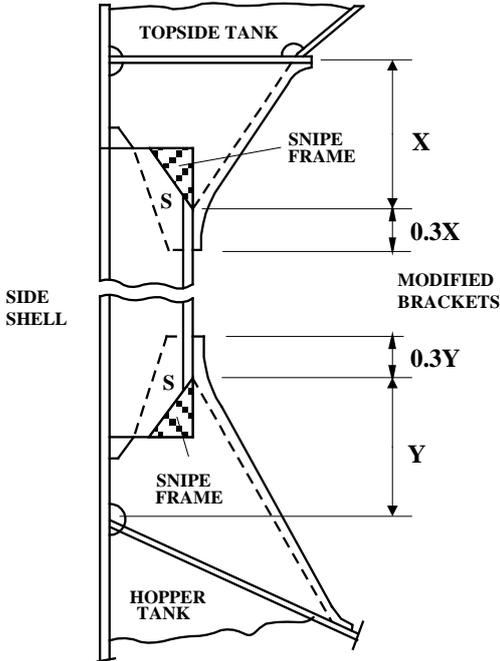
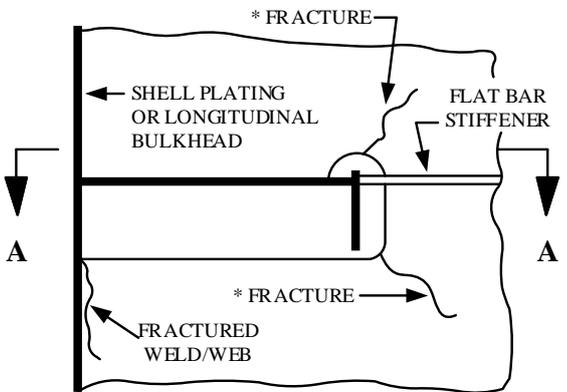
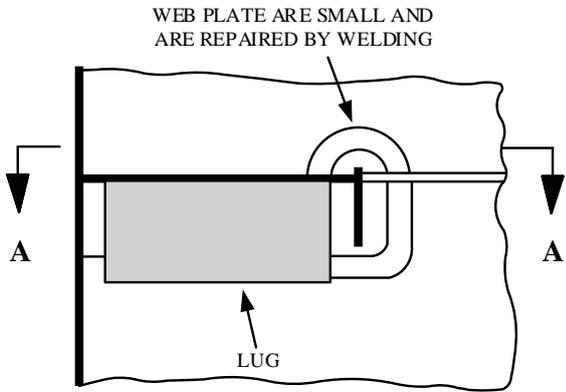
Ship Name: _____						
OWNERS INSPECTION REPORT – Structural Condition						
For Tank/Hold No.: _____						
Grade of Steel:	Deck:				Side:	_____
	Bottom:				Long. Bhd.	_____
Elements	Cracks	Buckles	Corrosion	Coating cond.	Pitting	Mod./Rep
Other						
Deck:						
Bottom:						
Side:						
Long. Bulkheads:						
Transv. Bulkheads:						
* Repairs carried out due to:						
Thickness measurements carried out, dates:						
Results in General:						
Overdue Surveys:						
Outstanding Conditions of class:						
Comments:						
* Repairs are to be surveyed by an ABS Surveyor						
Date of Inspection: _____						
Inspected by: _____						
Signature: _____						

7 ESP Survey Program – Double Skin Bulk Carriers (1 July 2008)

The following is a sample of the ESP Survey Program for Double Skin Bulk Carriers, with explanation of the information required in each section.

ESP SURVEY PROGRAM

Double Skin Bulk Carriers

Basic Information and Particulars

Name of ship:

IMO number:

Flag State:

Port of registry:

Gross tonnage:

Deadweight (metric tonnes):

Length between perpendiculars (m):

Shipbuilder:

Hull number:

Classification Society:

Class ID:

Date of build of the ship:

Owner:

Thickness measurement company:

1 Preamble

1.1 Scope

1.1.1 The present survey program covers the minimum extent of overall surveys, close-up surveys, thickness measurements and pressure testing within the cargo length area, cargo holds, and ballast tanks, including fore and aft peak tanks, required by the Rules.

1.1.2 The arrangements and safety aspects of the survey are to be acceptable to the attending Surveyor(s).

1.2 Documentation

All documents used in the development of the survey programme are to be available onboard during the survey as required by 7-3-2/11.

2 Arrangement of Cargo Holds, Tanks, and Spaces

This section of the survey program is to provide information (either in the form of plans or text) on the arrangement of cargo holds, tanks, and spaces that fall within the scope of the survey.

3 List of Cargo Holds, Tanks, and Spaces with Information on Their Use, Extent of Coatings and Corrosion Prevention System

This section of the survey program is to indicate any changes relating to (and is to update) the information on the use of the holds and tanks of the vessel, the extent of coatings and the corrosion prevention system provided in the Survey Planning Questionnaire.

4 Conditions for Survey

This section of the survey program is to provide information on the conditions for survey (e.g., information regarding cargo hold and tank cleaning, gas freeing, ventilation, lighting, etc.).

5 Provisions and Method of Access to Structures

This section of the survey program is to indicate any changes relating to (and is to update) the information on the provisions and methods of access to structures provided in the Survey Planning Questionnaire.

6 List of Equipment for Survey

This section of the survey program is to identify and list the equipment that will be made available for carrying out the survey and the required thickness measurements.

7 Survey Requirements**7.1 Overall Survey**

This section of the survey program is to identify and list the spaces that should undergo an overall survey for this vessel in accordance with 7-3-2/5.19.3.

7.2 Close-up Survey

This section of the survey program is to identify and list the hull structures that are to undergo a close-up survey for this vessel in accordance with 7-3-2/5.19.4.

8 Identification of Tanks for Tank Testing

This section of the survey program is to identify and list the cargo holds and tanks that are to undergo tank testing for this vessel in accordance with 7-3-2/5.19.6.

9 Identification of Areas and Sections for Thickness Measurements

This section of the survey program is to identify and list the areas and sections where thickness measurements are to be taken in accordance with 7-3-2/5.19.5.

10 Minimum Thickness of Hull Structures

This section of the survey program is to specify the minimum thickness for hull structures of this vessel that are subject to the Rules (indicate either (a) or preferably (b), if such information is available):

- (a) Determined from the attached wastage allowance table and the original thickness to the hull structure plans of the vessel;
- (b) Given in the following table(s):

Area or Location	Original As-built Thickness (mm)	Minimum Thickness (mm)	Substantial Corrosion Thickness (mm)
Deck			
Plating			
Longitudinals			
Longitudinal girders			
Cross deck plating			
Cross deck stiffeners			
Bottom			
Plating			
Longitudinals			
Longitudinal girders			

Area or Location	Original As-built Thickness (mm)	Minimum Thickness (mm)	Substantial Corrosion Thickness (mm)
Inner bottom			
Plating			
Longitudinals			
Longitudinal girders			
Floors			
Ship side in way of topside tanks			
Plating			
Longitudinals			
Ship side in way of hopper side tanks			
Plating			
Longitudinals			
Ship side in way of double hull tanks			
Plating			
Longitudinals or ordinary transverse frames			
Longitudinal stringers			
Longitudinal bulkhead (inner side)			
Plating			
Longitudinals or ordinary transverse frames			
Longitudinal girders (if applicable)			
Transverse bulkheads			
Plating			
Stiffeners (if applicable)			
Upper stool plating			
Upper stool stiffeners			
Lower stool plating			
Lower stool stiffeners			
Transverse web frames in topside tanks			
Plating			
Flanges			
Stiffeners			
Transverse web frames in double hull tanks			
Plating			
Flanges			
Stiffeners			
Transverse web frames in hopper tanks			
Plating			
Flanges			
Stiffeners			
Hatch Covers			
Plating			
Stiffeners			
Hatch Coamings			
Plating			
Stiffeners			

Note: The wastage allowance tables are to be attached to the survey program.

11 Thickness Measurement Company

This section of the survey program is to identify changes, if any, relating to the information on the thickness measurement company provided in the Survey Planning Questionnaire.

12 Damage Experience Related to the Vessel

This section of the survey program is to, using the tables provided below, provide details of the hull damages for at least the last three years in way of the cargo holds, ballast tanks, and void spaces within the cargo length area. These damages are subject to survey.

Hull Damages Sorted by Location for this Vessel

Cargo Hold, Tank or Space Number or Area	Possible Cause, if Known	Description of the Damages	Location	Repair	Date of Repair

**Hull Damages for Sister or Similar Vessels (if Available)
in the Case of Design Related Damage**

Cargo Hold, Tank or Space Number or Area	Possible Cause, if Known	Description of the Damages	Location	Repair	Date of Repair

13 Areas Identified with Substantial Corrosion from Previous Surveys

This section of the survey program is to identify and list the areas of substantial corrosion from previous surveys.

14 Critical Structural Areas and Suspect Areas

This section of the survey program is to identify and list the critical structural areas and the suspect areas, when such information is available.

15 Other Relevant Comments and Information

This section of the survey program is to provide any other comments and information relevant to the survey.

Appendices

Appendix 1 – List of Plans

Subparagraph 7-3-2/9.1.3 requires that main structural plans of cargo holds and ballast tanks (scantling drawings), including information regarding use of high tensile steel (HTS) are to be available. This Appendix of the survey program is to identify and list the main structural plans which form part of the survey program.

Appendix 2 – Survey Planning Questionnaire

The Survey Planning Questionnaire 7-A-8/9, which has been submitted by the Owner, is to be appended to the survey program.

Appendix 3 – Other Documentation

This part of the survey program is to identify and list any other documentation that forms part of the plan.

Prepared by the Owner in co-operation with the American Bureau of Shipping for compliance with 7-3-2/9.1.3:

Date:..... (name and signature of authorized Owner’s representative)

Date:..... (name and signature of authorized representative of the
American Bureau of Shipping)

9 ESP Survey Planning Questionnaire – Double Skin Bulk Carriers (1 July 2008)

The following is a sample of the ESP Survey Planning Questionnaire for Double Skin Bulk Carriers, with explanation of the information required in each section.

ESP SURVEY PLANNING QUESTIONNAIRE

Double Skin Bulk Carriers

1. The following information will enable the Owner in co-operation with the American Bureau of Shipping to develop a Survey Program complying with the requirements of the Rules. It is essential that the Owner provides, when completing the present questionnaire, up-to-date information. The present questionnaire, when completed, shall provide all information and material required by the Rules.

Particulars

Ship's name:

IMO number:

Flag State:

Port of registry:

Owner:

Classification Society:

Class ID:

Gross tonnage:

Deadweight (metric tonnes): Date of build:

Information on Access Provision for Close-up Surveys and Thickness Measurement

2. The Owner is to indicate, in the table below, the means of access to the structures subject to close-up survey and thickness measurement. A close-up survey is an examination where the details of structural components are within the close visual inspection range of the attending Surveyor (i.e., normally within reach of hand).

Hold/Tank No.	Structure	Temporary Staging	Rafts	Ladders	Direct Access	Other Means (Please Specify)
F.P.	Fore Peak					
A.P.	Aft Peak					
CARGO HOLDS	Hatch side coamings					
	Topside sloping plate					
	Upper stool plating					
	Cross deck					
	Double side tank plating					
	Transverse bulkhead					
	Hopper tank plating					
	Lower stool plating					
	Tank top					
TOPSIDE TANKS	Underdeck structure					
	Side shell & structure					
	Sloping plate & structure					
	Webs & bulkheads					
HOPPER TANKS	Hopper sloping plate & structure					
	Side shell & structure					
	Bottom structure					
	Webs & bulkheads					
DOUBLE SIDE SKIN TANKS	Side shell & structure					
	Inner skin & structure					
	Webs & bulkheads					
	Double bottom structure					
	Upper stool internal structure					
	Lower stool internal structure					
WING TANKS OF ORE CARRIERS	Underdeck & structure					
	Side shell & structure					
	Side shell vertical web & structure					
	Longitudinal bulkhead & structure					
	Longitudinal bulkhead web & structure					
	Bottom plating & structure					
	Cross ties/stringers					

History of Bulk Cargoes of a Corrosive Nature (e.g., high sulphur content)

--

Owner's Inspections

3. Using a format similar to that of the table below (which is given as an example), the Owner is to provide details of the results of their inspections, for the last 3 years – in accordance with the Rules – on all CARGO holds and BALLAST tanks and VOID spaces within the cargo area.

Tank/Hold No.	Corrosion Protection (1)	Coating Extent (2)	Coating Condition (3)	Structural Deterioration (4)	Hold and Tank History (5)
Cargo holds					
Topside tanks					
Hopper tanks					
Double side skin tanks					
Double bottom tanks					
Upper stools					
Lower stools					
Wing tanks (ore carriers)					
Fore peak					
Aft peak					
Miscellaneous other spaces:					

Note: Indicate tanks which are used for oil/ballast

- 1) HC = hard coating; SC = soft coating;
SH = semihard coating; NP = no protection
- 2) U = upper part; M = middle part;
L = lower part; C = complete
- 3) G = good; F = fair; P = poor;
RC = recoated (during the last 3 years)
- 4) N = no findings recorded; Y = findings recorded,
(Description of findings is to be attached to this questionnaire)
- 5) DR = Damage & Repair; L = Leakages;
CV = Conversion
(Description is to be attached to this questionnaire)

Name of Owner's Representative:

Signature:

Date:

Reports of Port State Control Inspections

List the reports of Port State Control inspections containing hull structural related deficiencies, relevant information on rectification of the deficiencies:

Safety Management System

List non-conformities related to hull maintenance, including the associated corrective actions:

Name and Address of the Approved Thickness Measurement Company:

11 ESP Survey Program – Non Double Skin Bulk Carriers (1 July 2008)

The following is a sample of the ESP Survey Program for Non Double Skin Bulk Carriers, with explanation of the information required in each section.

ESP SURVEY PROGRAM Non Double Skin Bulk Carriers

Basic Information and Particulars

Name of ship:
IMO number:
Flag State:
Port of registry:
Gross tonnage:
Deadweight (metric tonnes):
Length between perpendiculars (m):
Shipbuilder:
Hull number:
Classification Society:
Class ID:
Date of build of the ship:
Owner:
Thickness measurement company:

1 Preamble

1.1 Scope

1.1.1 The present survey program covers the minimum extent of overall surveys, close-up surveys, thickness measurements and pressure testing within the cargo length area, cargo holds, and ballast tanks, including fore and aft peak tanks, required by the Rules.

1.1.2 The arrangements and safety aspects of the survey are to be acceptable to the attending Surveyor(s).

1.2 Documentation

All documents used in the development of the survey programme are to be available onboard during the survey as required by 7-3-2/11.

2 Arrangement of Cargo Holds, Tanks, and Spaces

This section of the survey program is to provide information (either in the form of plans or text) on the arrangement of cargo holds, tanks, and spaces that fall within the scope of the survey.

3 List of Cargo Holds, Tanks, and Spaces with Information on Their Use, Extent of Coatings and Corrosion Prevention System

This section of the survey program is to indicate any changes relating to (and is to update) the information on the use of the holds and tanks of the vessel, the extent of coatings and the corrosion prevention system provided in the Survey Planning Questionnaire.

4 Conditions for Survey

This section of the survey program is to provide information on the conditions for survey (e.g., information regarding cargo hold and tank cleaning, gas freeing, ventilation, lighting, etc.).

5 Provisions and Method of Access to Structures

This section of the survey program is to indicate any changes relating to (and is to update) the information on the provisions and methods of access to structures provided in the Survey Planning Questionnaire.

6 List of Equipment for Survey

This section of the survey program is to identify and list the equipment that will be made available for carrying out the survey and the required thickness measurements.

7 Survey Requirements

7.1 Overall Survey

This section of the survey program is to identify and list the spaces that should undergo an overall survey for this vessel in accordance with 7-3-2/5.7.3.

7.2 Close-up Survey

This section of the survey program is to identify and list the hull structures that are to undergo a close-up survey for this vessel in accordance with 7-3-2/5.7.4.

8 Identification of Tanks for Tank Testing

This section of the survey program is to identify and list the cargo holds and tanks that are to undergo tank testing for this vessel in accordance with 7-3-2/5.7.6.

9 Identification of Areas and Sections for Thickness Measurements

This section of the survey program is to identify and list the areas and sections where thickness measurements are to be taken in accordance with 7-3-2/5.7.5.

10 Minimum Thickness of Hull Structures

This section of the survey program is to specify the minimum thickness for hull structures of this vessel that are subject to the Rules (indicate either (a) or preferably (b), if such information is available):

- (a) Determined from the attached wastage allowance table and the original thickness to the hull structure plans of the vessel;
- (b) Given in the following table(s):

Area or Location	Original As-built Thickness (mm)	Minimum Thickness (mm)	Substantial Corrosion Thickness (mm)
Deck			
Plating			
Longitudinals			
Longitudinal girders			
Cross deck plating			
Cross deck stiffeners			
Bottom			
Plating			
Longitudinals			
Longitudinal girders			
Inner bottom			
Plating			
Longitudinals			
Longitudinal girders			
Floors			
Ship side in way of topside tanks			
Plating			
Longitudinals			
Ship side in way of hopper side tanks			
Plating			
Longitudinals			
Ship side in way of tanks (if applicable)			
Plating			
Longitudinals or ordinary transverse frames			
Longitudinal stringers			
Ship side in way of cargo holds			
Plating			
Side frames webs			
Side frames flanges			
Upper brackets webs			
Upper brackets flanges			
Lower brackets webs			
Lower brackets flanges			
Longitudinal bulkhead (if applicable)			
Plating			
Longitudinals (if applicable)			
Longitudinal girders (if applicable)			
Transverse bulkheads			
Plating			
Stiffeners (if applicable)			
Upper stool plating			
Upper stool stiffeners			
Lower stool plating			
Lower stool stiffeners			

Area or Location	Original As-built Thickness (mm)	Minimum Thickness (mm)	Substantial Corrosion Thickness (mm)
Transverse web frames in topside tanks			
Plating			
Flanges			
Stiffeners			
Transverse web frames in hopper tanks			
Plating			
Flanges			
Stiffeners			
Hatch Covers			
Plating			
Stiffeners			
Hatch Coamings			
Plating			
Stiffeners			

Note: The wastage allowance tables are to be attached to the survey program.

11 Thickness Measurement Company

This section of the survey program is to identify changes, if any, relating to the information on the thickness measurement company provided in the Survey Planning Questionnaire.

12 Damage Experience Related to the Vessel

This section of the survey program is to, using the tables provided below, provide details of the hull damages for at least the last three years in way of the cargo holds, ballast tanks, and void spaces within the cargo length area. These damages are subject to survey.

Hull Damages Sorted by Location for this Vessel

Cargo Hold, Tank or Space Number or Area	Possible Cause, if Known	Description of the Damages	Location	Repair	Date of Repair

**Hull Damages for Sister or Similar Vessels (if Available)
in the Case of Design Related Damage**

Cargo Hold, Tank or Space Number or Area	Possible Cause, if Known	Description of the Damages	Location	Repair	Date of Repair

13 Areas Identified with Substantial Corrosion from Previous Surveys

This section of the survey program is to identify and list the areas of substantial corrosion from previous surveys.

14 Critical Structural Areas and Suspect Areas

This section of the survey program is to identify and list the critical structural areas and the suspect areas, when such information is available.

15 Other Relevant Comments and Information

This section of the survey program is to provide any other comments and information relevant to the survey.

Appendices

Appendix 1 – List of Plans

Subparagraph 7-3-2/9.1.3 requires that main structural plans of cargo holds and ballast tanks (scantling drawings), including information regarding use of high tensile steel (HTS) are to be available. This Appendix of the survey program is to identify and list the main structural plans which form part of the survey program.

Appendix 2 – Survey Planning Questionnaire

The Survey Planning Questionnaire 7-A-8/13, which has been submitted by the Owner, is to be appended to the survey program.

Appendix 3 – Other Documentation

This part of the survey program is to identify and list any other documentation that forms part of the plan.

Prepared by the Owner in co-operation with the American Bureau of Shipping for compliance with 7-3-2/9.1.3:

Date: (name and signature of authorized Owner’s representative)

Date: (name and signature of authorized representative of the American Bureau of Shipping)

13 ESP Survey Planning Questionnaire – Non Double Skin Bulk Carriers (1 July 2008)

The following is a sample of the ESP Survey Planning Questionnaire for Non Double Skin Bulk Carriers, with explanation of the information required in each section.

ESP SURVEY PLANNING QUESTIONNAIRE

Non Double Skin Bulk Carriers

1. The following information will enable the Owner in co-operation with the American Bureau of Shipping to develop a Survey Program complying with the requirements of the Rules. It is essential that the Owner provides, when completing the present questionnaire, up-to-date information. The present questionnaire, when completed, shall provide all information and material required by the Rules.

Particulars

Ship's name:

IMO number:

Flag State:

Port of registry:

Owner:

Classification Society:

Class ID:

Gross tonnage:

Deadweight (metric tonnes): Date of build:

Information on Access Provision for Close-up Surveys and Thickness Measurement

2. The Owner is to indicate, in the table below, the means of access to the structures subject to close-up survey and thickness measurement. A close-up survey is an examination where the details of structural components are within the close visual inspection range of the attending Surveyor (i.e., normally within reach of hand).

Hold/Tank No.	Structure	Temporary Staging	Rafts	Ladders	Direct Access	Other Means (Please Specify)
F.P.	Fore Peak					
A.P.	Aft Peak					
CARGO HOLDS	Hatch side coamings					
	Topside sloping plate					
	Upper stool plating					
	Cross deck					
	Side shell, frames & brackets					
	Transverse bulkhead					
	Hopper tank plating					
	Lower stool plating					
	Tank top					
TOPSIDE TANKS	Underdeck structure					
	Side shell & structure					
	Sloping plate & structure					
	Webs & bulkheads					
HOPPER TANKS	Hopper sloping plate & structure					
	Side shell & structure					
	Bottom structure					
	Webs & bulkheads					
	Double bottom structure					
	Upper stool internal structure					
Lower stool internal structure						

History of Bulk Cargoes of a Corrosive Nature (e.g., high sulphur content)

--

Owner's Inspections

3. Using a format similar to that of the table below (which is given as an example), the Owner is to provide details of the results of their inspections, for the last 3 years – in accordance with the Rules – on all CARGO holds and BALLAST tanks and VOID spaces within the cargo area.

Tank/Hold No.	Corrosion Protection (1)	Coating Extent (2)	Coating Condition (3)	Structural Deterioration (4)	Hold and Tank History (5)
Cargo holds					
Topside tanks					
Hopper tanks					
Double bottom tanks					
Upper stools					
Lower stools					
Fore peak					
Aft peak					
Miscellaneous other spaces:					

Note: Indicate tanks which are used for oil/ballast

- 1) HC = hard coating; SC = soft coating;
SH = semihard coating; NP = no protection
- 2) U = upper part; M = middle part;
L = lower part; C = complete
- 3) G = good; F = fair; P = poor;
RC = recoated (during the last 3 years)
- 4) N = no findings recorded; Y = findings recorded,
(Description of findings is to be attached to this questionnaire)
- 5) DR = Damage & Repair; L = Leakages;
CV = Conversion
(Description is to be attached to this questionnaire)

Name of Owner's Representative:

Signature:

Date:

Reports of Port State Control Inspections

List the reports of Port State Control inspections containing hull structural related deficiencies, relevant information on rectification of the deficiencies:

Safety Management System

List non-conformities related to hull maintenance, including the associated corrective actions:

Name and Address of the Approved Thickness Measurement Company:

15 ESP Survey Program – Double Hull Oil Tankers and Chemical Carriers (2010)

The following is a sample of the ESP Survey Program for Double Hull Oil Tankers and Chemical Carriers, with explanation of the information required in each section.

ESP SURVEY PROGRAM

Double Hull Oil Tankers and Chemical Carriers

Basic Information and Particulars

Name of ship:

IMO number:

Flag State:

Port of registry:

Gross tonnage:

Deadweight (metric tonnes):

Length between perpendiculars (m):

Shipbuilder:

Hull number:

Classification Society:

Class ID:

Date of build of the ship:

Owner:

Thickness measurement company:

1 Preamble

1.1 Scope

1.1.1 The present survey program covers the minimum extent of overall surveys, close-up surveys, thickness measurements and pressure testing within the cargo length area, cargo holds, and ballast tanks, including fore and aft peak tanks, required by the Rules.

1.1.2 The arrangements and safety aspects of the survey are to be acceptable to the attending Surveyor(s).

1.2 Documentation

All documents used in the development of the survey programme are to be available onboard during the survey as required by 7-3-2/11.

2 Arrangement of Cargo Holds, Tanks, and Spaces

This section of the survey program is to provide information (either in the form of plans or text) on the arrangement of cargo holds, tanks, and spaces that fall within the scope of the survey.

3 List of Cargo Holds, Tanks, and Spaces with Information on Their Use, Extent of Coatings and Corrosion Prevention System

This section of the survey program is to indicate any changes relating to (and is to update) the information on the use of the holds and tanks of the vessel, the extent of coatings and the corrosion prevention system provided in the Survey Planning Questionnaire.

4 Conditions for Survey

This section of the survey program is to provide information on the conditions for survey (e.g., information regarding cargo hold and tank cleaning, gas freeing, ventilation, lighting, etc.).

5 Provisions and Method of Access to Structures

This section of the survey program is to indicate any changes relating to (and is to update) the information on the provisions and methods of access to structures provided in the Survey Planning Questionnaire.

6 List of Equipment for Survey

This section of the survey program is to identify and list the equipment that will be made available for carrying out the survey and the required thickness measurements.

7 Survey Requirements**7.1 Overall Survey**

This section of the survey program is to identify and list the spaces that should undergo an overall survey for this vessel in accordance with 7-3-2/5.14.3 and 7-3-2/5.21.3 for Chemical Carriers.

7.2 Close-up Survey

This section of the survey program is to identify and list the hull structures that are to undergo a close-up survey for this vessel in accordance with 7-3-2/5.14.4 and 7-3-2/5.21.4 for Chemical Carriers.

8 Identification of Tanks for Tank Testing and Pipes for Pipe Testing (2012)

This section of the survey program is to identify and list the cargo holds and tanks that are to undergo tank testing for this vessel in accordance with 7-3-2/5.14.6 and 7-3-2/5.21.6 for Chemical Carriers and pipes for pipe testing per 7-3-2/5.21.7 for Chemical Carriers.

9 Identification of Areas and Sections for Thickness Measurements

This section of the survey program is to identify and list the areas and sections where thickness measurements are to be taken in accordance with 7-3-2/5.14.5 and 7-3-2/5.21.5 for Chemical Carriers.

10 Minimum Thickness of Hull Structures

This section of the survey program is to specify the minimum thickness for hull structures of this vessel that are subject to the Rules (indicate either (a) or preferably (b), if such information is available):

- (a) Determined from the attached wastage allowance table and the original thickness to the hull structure plans of the vessel;
- (b) Given in the following table(s):

Area or Location	Original As-built Thickness (mm)	Minimum Thickness (mm)	Substantial Corrosion Thickness (mm)
Deck			
Plating			
Longitudinals			
Longitudinal girders			
Bottom			
Plating			
Longitudinals			
Longitudinal girders			

Area or Location	Original As-built Thickness (mm)	Minimum Thickness (mm)	Substantial Corrosion Thickness (mm)
Ship side			
Plating			
Longitudinals			
Longitudinal girders			
Longitudinal bulkhead			
Plating			
Longitudinals			
Longitudinal girders			
Inner bottom			
Plating			
Longitudinals			
Longitudinal girders			
Transverse bulkheads			
Plating			
Stiffeners			
Transverse web frames, floors and stringers			
Plating			
Flanges			
Stiffeners			
Cross ties			
Flanges			
Webs			

Note: The wastage allowance tables are to be attached to the survey program.

11 Thickness Measurement Company

This section of the survey program is to identify changes, if any, relating to the information on the thickness measurement company provided in the Survey Planning Questionnaire.

12 Damage Experience Related to the Vessel

This section of the survey program is to, using the tables provided below, provide details of the hull damages for at least the last three years in way of the cargo holds, ballast tanks, and void spaces within the cargo length area. These damages are subject to survey.

Hull Damages Sorted by Location for this Vessel

Tank or Space Number or Area	Possible Cause, if Known	Description of the Damages	Location	Repair	Date of Repair

**Hull Damages for Sister or Similar Vessels (if Available)
in the Case of Design Related Damage**

Tank or Space Number or Area	Possible Cause, if Known	Description of the Damages	Location	Repair	Date of Repair

13 Areas Identified with Substantial Corrosion from Previous Surveys

This section of the survey program is to identify and list the areas of substantial corrosion from previous surveys.

14 Critical Structural Areas and Suspect Areas

This section of the survey program is to identify and list the critical structural areas and the suspect areas, when such information is available.

15 Other Relevant Comments and Information

This section of the survey program is to provide any other comments and information relevant to the survey.

Appendices

Appendix 1 – List of Plans

Subparagraph 7-3-2/9.1.3 requires that main structural plans of cargo holds and ballast tanks (scantling drawings), including information regarding use of high tensile steel (HTS) are to be available. This Appendix of the survey program is to identify and list the main structural plans which form part of the survey program.

Appendix 2 – Survey Planning Questionnaire

The Survey Planning Questionnaire 7-A-8/17, which has been submitted by the Owner, is to be appended to the survey program.

Appendix 3 – Other Documentation

This part of the survey program is to identify and list any other documentation that forms part of the plan.

Prepared by the Owner in co-operation with the American Bureau of Shipping for compliance with 7-3-2/9.1.3:

Date: (name and signature of authorized Owner's representative)

Date: (name and signature of authorized representative of the
American Bureau of Shipping)

17 ESP Survey Planning Questionnaire – Double Hull Oil Tankers and Chemical Carriers (2010)

The following is a sample of the ESP Survey Planning Questionnaire for Double Hull Oil Tankers and Chemical Carriers, with explanation of the information required in each section.

ESP SURVEY PLANNING QUESTIONNAIRE

Double Hull Oil Tankers and Chemical Carriers

1. The following information will enable the Owner in co-operation with the American Bureau of Shipping to develop a Survey Program complying with the requirements of the Rules. It is essential that the Owner provides, when completing the present questionnaire, up-to-date information. The present questionnaire, when completed, shall provide all information and material required by the Rules.

Particulars

Ship's name:

IMO number:

Flag State:

Port of registry:

Owner:

Classification Society:

Class ID:

Gross tonnage:

Deadweight (metric tonnes): Date of build:

Information on Access Provision for Close-up Surveys and Thickness Measurement

2. The Owner is to indicate, in the table below, the means of access to the structures subject to close-up survey and thickness measurement. A close-up survey is an examination where the details of structural components are within the close visual inspection range of the attending Surveyor (i.e., normally within reach of hand).

Tank No.	Structure	C(Cargo)/ B(Ballast)	Temporary Staging	Rafts	Ladders	Direct Access	Other Means (Please Specify)
F.P.	Fore Peak						
A.P.	Aft Peak						
Wing Tanks	Under deck						
	Side shell						
	Bottom transverse						
	Longitudinal						
	Transverse						
Center Tanks	Under deck						
	Bottom transverse						
	Transverse						

History of Cargo with H₂S Content or Heated Cargo for the Last 3 Years Together with Indication as to Whether Cargo was Heated and, Where Available, Marine Safety Data Sheets (MSDS)*

--

* Refer to resolution MSC. 150(77) on Recommendation for material safety data sheets for MARPOL Annex I cargoes and marine fuel oils.

Owner's Inspections

3. Using a format similar to that of the table below (which is given as an example), the Owner is to provide details of the results of their inspections, for the last 3 years on all cargo and ballast tanks and void spaces within the cargo area, including peak tanks.

Tank No.	Corrosion Protection (1)	Coating Extent (2)	Coating Condition (3)	Structural Deterioration (4)	Hold and Tank History (5)
Cargo center tanks					
Cargo wing tanks					
Slop					
Ballast tanks					
Aft peak					
Fore peak					
Miscellaneous spaces					

Note: Indicate tanks which are used for oil/ballast

- 1) HC = hard coating; SC = soft coating;
SH = semihard coating; NP = no protection
- 2) U = upper part; M = middle part;
L = lower part; C = complete
- 3) G = good; F = fair; P = poor;
RC = recoated (during the last 3 years)
- 4) N = no findings recorded; Y = findings recorded,
(Description of findings is to be attached to this questionnaire)
- 5) DR = Damage & Repair; L = Leakages;
CV = Conversion
(Description is to be attached to this questionnaire)

Name of Owner's Representative:

Signature:

Date:

Reports of Port State Control Inspections

List the reports of Port State Control inspections containing hull structural related deficiencies, relevant information on rectification of the deficiencies:

Safety Management System

List non-conformities related to hull maintenance, including the associated corrective actions:

Name and Address of the Approved Thickness Measurement Company:

19 ESP Survey Program – Non Double Hull Oil Tankers and Chemical Carriers (2010)

The following is a sample of the ESP Survey Program for Non Double Hull Oil Tankers and Chemical Carriers, with explanation of the information required in each section.

ESP SURVEY PROGRAM

Non Double Hull Oil Tankers and Chemical Carriers

Basic Information and Particulars

Name of ship:

IMO number:

Flag State:

Port of registry:

Gross tonnage:

Deadweight (metric tonnes):

Length between perpendiculars (m):

Shipbuilder:

Hull number:

Classification Society:

Class ID:

Date of build of the ship:

Owner:

Thickness measurement company:

1 Preamble

1.1 Scope

1.1.1 The present survey program covers the minimum extent of overall surveys, close-up surveys, thickness measurements and pressure testing within the cargo length area, cargo holds, and ballast tanks, including fore and aft peak tanks, required by the Rules.

1.1.2 The arrangements and safety aspects of the survey are to be acceptable to the attending Surveyor(s).

1.2 Documentation

All documents used in the development of the survey programme are to be available onboard during the survey as required by 7-3-2/11.

2 Arrangement of Cargo Holds, Tanks, and Spaces

This section of the survey program is to provide information (either in the form of plans or text) on the arrangement of cargo holds, tanks, and spaces that fall within the scope of the survey.

3 List of Cargo Holds, Tanks, and Spaces with Information on Their Use, Extent of Coatings and Corrosion Prevention System

This section of the survey program is to indicate any changes relating to (and is to update) the information on the use of the holds and tanks of the vessel, the extent of coatings and the corrosion prevention system provided in the Survey Planning Questionnaire.

4 Conditions for Survey

This section of the survey program is to provide information on the conditions for survey (e.g., information regarding cargo hold and tank cleaning, gas freeing, ventilation, lighting, etc.).

5 Provisions and Method of Access to Structures

This section of the survey program is to indicate any changes relating to (and is to update) the information on the provisions and methods of access to structures provided in the Survey Planning Questionnaire.

6 List of Equipment for Survey

This section of the survey program is to identify and list the equipment that will be made available for carrying out the survey and the required thickness measurements.

7 Survey Requirements**7.1 Overall Survey**

This section of the survey program is to identify and list the spaces that should undergo an overall survey for this vessel in accordance with 7-3-2/5.13.3 and 7-3-2/5.21.3 for Chemical Carriers.

7.2 Close-up Survey

This section of the survey program is to identify and list the hull structures that are to undergo a close-up survey for this vessel in accordance with 7-3-2/5.13.4 and 7-3-2/5.21.4 for Chemical Carriers.

8 Identification of Tanks for Tank Testing and Pipes for Pipe Testing (2012)

This section of the survey program is to identify and list the cargo holds and tanks that are to undergo tank testing for this vessel in accordance with 7-3-2/5.13.6 and 7-3-2/5.21.6 for Chemical Carriers and pipes for pipe testing per 7-3-2/5.21.7 for Chemical Carriers.

9 Identification of Areas and Sections for Thickness Measurements

This section of the survey program is to identify and list the areas and sections where thickness measurements are to be taken in accordance with 7-3-2/5.13.5 and 7-3-2/5.21.5 for Chemical Carriers.

10 Minimum Thickness of Hull Structures

This section of the survey program is to specify the minimum thickness for hull structures of this vessel that are subject to the Rules (indicate either (a) or preferably (b), if such information is available):

- (a) Determined from the attached wastage allowance table and the original thickness to the hull structure plans of the vessel;
- (b) Given in the following table(s):

Area or Location	Original As-built Thickness (mm)	Minimum Thickness (mm)	Substantial Corrosion Thickness (mm)
Deck			
Plating			
Longitudinals			
Longitudinal girders			
Bottom			
Plating			
Longitudinals			
Longitudinal girders			

Area or Location	Original As-built Thickness (mm)	Minimum Thickness (mm)	Substantial Corrosion Thickness (mm)
Ship side			
Plating			
Longitudinals			
Longitudinal girders			
Longitudinal bulkhead			
Plating			
Longitudinals			
Longitudinal girders			
Inner bottom			
Plating			
Longitudinals			
Longitudinal girders			
Transverse bulkheads			
Plating			
Stiffeners			
Transverse web frames, floors and stringers			
Plating			
Flanges			
Stiffeners			
Cross ties			
Flanges			
Webs			

Note: The wastage allowance tables are to be attached to the survey program.

11 Thickness Measurement Company

This section of the survey program is to identify changes, if any, relating to the information on the thickness measurement company provided in the Survey Planning Questionnaire.

12 Damage Experience Related to the Vessel

This section of the survey program is to, using the tables provided below, provide details of the hull damages for at least the last three years in way of the cargo holds, ballast tanks, and void spaces within the cargo length area. These damages are subject to survey.

Hull Damages Sorted by Location for this Vessel

Tank or Space Number or Area	Possible Cause, if Known	Description of the Damages	Location	Repair	Date of Repair

**Hull Damages for Sister or Similar Vessels (if Available)
in the Case of Design Related Damage**

Tank or Space Number or Area	Possible Cause, if Known	Description of the Damages	Location	Repair	Date of Repair

13 Areas Identified with Substantial Corrosion from Previous Surveys

This section of the survey program is to identify and list the areas of substantial corrosion from previous surveys.

14 Critical Structural Areas and Suspect Areas

This section of the survey program is to identify and list the critical structural areas and the suspect areas, when such information is available.

15 Other Relevant Comments and Information

This section of the survey program is to provide any other comments and information relevant to the survey.

Appendices

Appendix 1 – List of Plans

Subparagraph 7-3-2/9.1.3 requires that main structural plans of cargo holds and ballast tanks (scantling drawings), including information regarding use of high tensile steel (HTS) are to be available. This Appendix of the survey program is to identify and list the main structural plans which form part of the survey program.

Appendix 2 – Survey Planning Questionnaire

The Survey Planning Questionnaire 7-A-8/21, which has been submitted by the Owner, is to be appended to the survey program.

Appendix 3 – Other Documentation

This part of the survey program is to identify and list any other documentation that forms part of the plan.

Prepared by the Owner in co-operation with the American Bureau of Shipping for compliance with 7-3-2/9.1.3:

Date:..... (name and signature of authorized Owner’s representative)

Date:..... (name and signature of authorized representative of the American Bureau of Shipping)

21 ESP Survey Planning Questionnaire – Non Double Hull Oil Tankers and Chemical Carriers (2010)

The following is a sample of the ESP Survey Planning Questionnaire for Non Double Hull Oil Tankers and Chemical Carriers, with explanation of the information required in each section.

ESP SURVEY PLANNING QUESTIONNAIRE

Non Double Hull Oil Tankers and Chemical Carriers

1. The following information will enable the Owner in co-operation with the American Bureau of Shipping to develop a Survey Program complying with the requirements of the Rules. It is essential that the Owner provides, when completing the present questionnaire, up-to-date information. The present questionnaire, when completed, shall provide all information and material required by the Rules.

Particulars

Ship's name:

IMO number:

Flag State:

Port of registry:

Owner:

Classification Society:

Class ID:

Gross tonnage:

Deadweight (metric tonnes): Date of build:

Information on Access Provision for Close-up Surveys and Thickness Measurement

2. The Owner is to indicate, in the table below, the means of access to the structures subject to close-up survey and thickness measurement. A close-up survey is an examination where the details of structural components are within the close visual inspection range of the attending Surveyor (i.e., normally within reach of hand).

Tank No.	Structure	C(Cargo)/ B(Ballast)	Temporary Staging	Rafts	Ladders	Direct Access	Other Means (Please Specify)
F.P.	Fore Peak						
A.P.	Aft Peak						
Wing Tanks	Under deck						
	Side shell						
	Bottom transverse						
	Longitudinal						
	Transverse						
Center Tanks	Under deck						
	Bottom transverse						
	Transverse						

History of Cargo with H₂S Content or Heated Cargo for the Last 3 Years Together with Indication as to Whether Cargo was Heated and, Where Available, Marine Safety Data Sheets (MSDS)*

* Refer to resolution MSC. 150(77) on Recommendation for material safety data sheets for MARPOL Annex I cargoes and marine fuel oils.

Owner's Inspections

3. Using a format similar to that of the table below (which is given as an example), the Owner is to provide details of the results of their inspections, for the last 3 years on all cargo and ballast tanks and void spaces within the cargo area, including peak tanks.

Tank No.	Corrosion Protection (1)	Coating Extent (2)	Coating Condition (3)	Structural Deterioration (4)	Hold and Tank History (5)
Cargo center tanks					
Cargo wing tanks					
Slop					
Ballast tanks					
Aft peak					
Fore peak					
Miscellaneous spaces					

Note: Indicate tanks which are used for oil/ballast

- 1) HC = hard coating; SC = soft coating;
SH = semihard coating; NP = no protection
- 2) U = upper part; M = middle part;
L = lower part; C = complete
- 3) G = good; F = fair; P = poor;
RC = recoated (during the last 3 years)
- 4) N = no findings recorded; Y = findings recorded,
(Description of findings is to be attached to this questionnaire)
- 5) DR = Damage & Repair; L = Leakages;
CV = Conversion
(Description is to be attached to this questionnaire)

Name of Owner's Representative:

Signature:

Date:

Reports of Port State Control Inspections

List the reports of Port State Control inspections containing hull structural related deficiencies, relevant information on rectification of the deficiencies:

Safety Management System

List non-conformities related to hull maintenance, including the associated corrective actions:

Name and Address of the Approved Thickness Measurement Company:

PART 7

APPENDIX

SECTION 9 Reporting Principles for ESP Vessels

As a principle, for bulk carriers, oil carriers and chemical carriers subject to ESP, the Surveyor is to include the following content in the report for survey of hull structure and piping systems, as relevant for the survey.

1 General

A survey report is to be generated in the following cases:

- In connection with commencement, continuation and/or completion of periodical hull surveys, i.e., annual, intermediate and special surveys, as relevant
- When structural damages/defects have been found
- When repairs, renewals or modifications have been carried out
- When condition of class (recommendation) has been imposed or deleted

The purpose of reporting is to provide:

- Evidence that prescribed surveys have been carried out in accordance with applicable classification rules
- Documentation of surveys carried out with findings, repairs carried out and a recommendation imposed or deleted
- Survey records, including actions taken, which shall form an auditable documentary trail. Survey reports are to be kept in the survey report file required to be onboard
- Information for planning of future surveys
- Information which may be used as input for maintenance of classification rules and instructions

When a survey is split between different survey stations, a report is to be made for each portion of the survey. A list of items surveyed, relevant findings and an indication of whether the item has been credited, is to be made available to the next attending Surveyor, prior to continuing or completing the survey. Thickness measurement and tank testing carried out is also to be listed for the next Surveyor.

3 Extent of the Survey

Identification of compartments where an overall survey has been carried out.

Identification of locations, in each tank, where a close-up survey has been carried out, together with information of the means of access used.

Identification of locations, in each tank, where thickness measurement has been carried out.

Note: As a minimum, the identification of location of close-up survey and thickness measurement is to include a confirmation with description of individual structural members corresponding to the extent of requirements stipulated in Section 7-3-2 based on type of periodical survey and the ship's age.

Where only partial survey is required, e.g., 25% of shell frames, one transverse web, two selected transverse cargo hold transverse bulkheads, one web frame ring/one deck transverse, the identification is to include location within each tank and cargo hold by reference to frame numbers.

For areas in tanks where protective coating is found to be in GOOD condition and the extent of close-up survey and/or thickness measurement has been specially considered, structures subject to special consideration are to be identified.

Identification of tanks subject to tank testing.

Identification of cargo piping on deck, including crude oil washing (COW) piping, and cargo and ballast piping within cargo and ballast tanks, pump rooms, pipe tunnels and void spaces, where:

- Examination including internal examination of piping with valves and fittings and thickness measurement, as relevant, has been carried out
- Operational test to working pressure has been carried out

5 Result of the Survey

(1 July 2006) Type, extent and condition of hard protective coating in each tank, as relevant (rated GOOD, FAIR or POOR).

Structural condition of each compartment with information on the following, as relevant:

Identification of findings, such as:

- Corrosion with description of location, type and extent
- Areas with substantial corrosion
- Cracks/fractures with description of location and extent
- Buckling with description of location and extent
- Indents with description of location and extent

Identification of compartments where no structural damages/defects are found

The report may be supplemented by sketches/photos.

Thickness measurement report is to be verified and signed by the Surveyor controlling the measurements on board.

Evaluation result of longitudinal strength of the hull girder of oil tankers of 130 m in length and upwards and over 10 years of age. The following data is to be included, as relevant:

- Measured and as-built transverse sectional areas of deck and bottom flanges
- Diminution of transverse sectional areas of deck and bottom flanges
- Details of renewals or reinforcements carried out, as relevant (as per 7-A-9/7)

7 Actions Taken with Respect to Findings (1 July 2008)

Whenever the attending Surveyor is of the opinion that repairs are required, each item to be repaired is to be identified in the survey report. Whenever repairs are carried out, details of the repairs effected are to be reported by making specific reference to relevant items in the survey report.

Repairs carried out are to be reported with identification of:

- Compartment
- Structural member
- Repair method (i.e. renewal or modification) including steel grades and scantlings (if different from the original); sketches/photos, as appropriate
- Repair extent
- NDT/Tests

For repairs not completed at the time of survey, a recommendation is to be imposed with a specific time limit for the repairs. In order to provide correct and proper information to the Surveyor attending for survey of the repairs, condition of class (recommendation) is to be sufficiently detailed with identification of each item to be repaired. For identification of extensive repairs, reference may be given to the survey report.

REPORT 1
Condition Evaluation Report for Bulk Carriers
Condition Evaluation Report

Issued upon Completion of Special Periodical Survey

GENERAL PARTICULARS

SHIPS NAME:	ABS IDENTIFICATION NUMBER:
	IMO IDENTITY NUMBER:
PORT OF REGISTRY:	NATIONAL FLAG:
DEADWEIGHT (M. TONNES):	GROSS TONNAGE:
DATE OF BUILD:	CLASSIFICATION NOTATION:
DATE OF MAJOR CONVERSION:	OWNER

TYPE OF CONVERSION

- a) The survey reports and documents listed below have been reviewed by the undersigned and found to be satisfactory.
- b) A Summary of the survey is attached herewith on sheet 2.
- c) The Special Periodical Survey – Hull has been completed in accordance with the Regulations on [date].

Condition Evaluation Report completed by:	Name Signature	Title
OFFICE	DATE.	
Condition Evaluation Report verified by:	Name Signature	Title
OFFICE	DATE	

Attached reports and documents:

- 1)
- 2)
- 3)
- 4)
- 5)
- 6)

Condition Evaluation Report

- A) General Particulars: - See front page
- B) Report Review: - Where and how survey was done
- C) Close-up Survey: - Extent (Which tanks/holds)
- D) Thickness measurements: - Reference to Thickness Measurement report
 - Summary of where measured
 - Separate form indicating the Spaces with Substantial Corrosion, and corresponding
 - * Thickness diminution
 - * Corrosion pattern
- E) Tank Protection: Separate form indicating:
 - (*1 July 2006*) Location of coating
 - Condition of coating (as applicable)
- F) Repairs: - Identification of spaces/areas
- G) Condition of Class/Recommendations:
- H) Memoranda: - Items noted for record
 - Any points of attention for future surveys, e.g., for Suspect Areas.
 - Extended Annual/Intermediate Survey due to coating breakdown
- I) Conclusion: - Statement on evaluation/verification of Survey report

Extract of Thickness Measurements, A – non CSR Vessels (1 July 2013)

Reference is made to the thickness measurements report:

1 <i>Position of substantially corroded Spaces/Areas or Areas with deep pitting.</i>	<i>Thickness diminution [%]</i>	2 <i>Corrosion pattern</i>	<i>Remarks: e.g., Ref. attached sketches</i>

Remarks

1 Substantial corrosion, i.e., 75–100% of acceptable margins wasted

2 P = Pitting

C = Corrosion in General

Any bottom plating with a pitting intensity of 20% or more, with wastage in the substantial corrosion range or having an average depth of pitting of 1/3 or more of actual plate thickness is to be noted.

Extract of Thickness Measurements, B – CSR Vessels (1 July 2013)

Reference is made to the thickness measurements report:

1 <i>Position of substantially Corroded Tanks/Areas or Areas with deep pitting</i>	$t_m - t_{ren}$ (mm)	2 <i>Corrosion pattern</i>	<i>Remarks: e.g., Ref. attached sketches</i>

Remarks

- 1 Substantial corrosion, an extent of corrosion such that the assessment of the corrosion pattern indicates a measured thickness between $t_{ren} + 0.5$ mm and t_{ren} .
- 2 P = Pitting
 C = Corrosion in General
 Areas with deep pitting assessed according to 7-A-4/35 are to be recorded in this column.

Tank/Hold Protection

1 <i>Tank/Hold Nos.</i>	2 <i>Tank/Hold protection</i>	3 <i>Coating condition</i>	<i>Remarks</i>

Remarks

- 1 All ballast tanks and cargo holds to be listed.
- 2 (1 July 2006) C = Coating NP = No Protection
- 3 Coating condition according to the following standard.
 - GOOD** condition with only minor spot rusting.
 - FAIR** condition with local breakdown at edges of stiffeners and weld connections and/or light rusting over 20% or more of areas under consideration, but less than as defined for POOR condition.
 - POOR** condition with general breakdown of coating over 20% or more of areas or hard scale at 10% or more of areas under consideration.

If coating condition "POOR" is given, extended Annual Surveys are to be introduced. This is to be noted in part H) of the Condition Evaluation Report.

REPORT 2

Condition Evaluation Report for Oil Carriers and Chemical Carriers

Condition Evaluation Report

Issued upon Completion of Special Periodical Survey

GENERAL PARTICULARS

SHIPS NAME:

ABS IDENTIFICATION NUMBER:

IMO IDENTITY NUMBER:

PORT OF REGISTRY:

NATIONAL FLAG:

DEADWEIGHT (M. TONNES):

GROSS TONNAGE:

DATE OF BUILD:

CLASSIFICATION NOTATION:

DATE OF MAJOR CONVERSION:

OWNER

TYPE OF CONVERSION

- a) The survey reports and documents listed below have been reviewed by the undersigned and found to be satisfactory.
- b) A Summary of the survey is attached herewith on sheet 2.
- c) The Special Periodical Survey – Hull has been completed in accordance with the Regulations on [date].

Condition Evaluation Report completed by:	Name Signature	Title
OFFICE	DATE.	
Condition Evaluation Report verified by:	Name Signature	Title
OFFICE	DATE	

Attached reports and documents:

- 1)
- 2)
- 3)
- 4)
- 5)
- 6)

Condition Evaluation Report (2001)

- A) General Particulars: - See front page
- B) Report Review: - Where and how survey was done
- C) Close-up Survey: - Extent (Which tanks)
- D) Cargo & Ballast Piping System - Examined
- Operationally Tested
- E) Thickness measurements: - Reference to Thickness Measurement report
- Summary of where measured
- Separate form indicating the tanks/areas with Substantial Corrosion, and corresponding
- * Thickness diminution
- * Corrosion pattern
- F) Tank Protection: Separate form indicating:
- (1 July 2006) Location of coating
- Condition of coating (as applicable)
- G) Repairs: - Identification of tanks/areas
- H) Condition of Class/Recommendations:
- I) Memoranda: - Items noted for record
- Any points of attention for future surveys, e.g., for Suspect Areas.
- Extended Annual/Intermediate Survey due to coating breakdown
- J) (1 July 2002) Evaluation of the vessel's longitudinal strength (for oil carriers of 130 m in length and upwards of over 10 years of age)
- K) Conclusion: - Statement on evaluation/verification of Survey report

Extract of Thickness Measurements, A – non CSR Vessels (1 July 2013)

Reference is made to the thickness measurements report:

1 <i>Position of substantially corroded Tanks/Areas or Areas with deep pitting.</i>	<i>Thickness diminution [%]</i>	2 <i>Corrosion pattern</i>	<i>Remarks: e.g., Ref. attached sketches</i>

Remarks

1 Substantial corrosion, i.e., 75–100% of acceptable margins wasted

2 P = Pitting

C = Corrosion in General

Any bottom plating with a pitting intensity of 20% or more, with wastage in the substantial corrosion range or having an average depth of pitting of 1/3 or more of actual plate thickness is to be noted.

Extract of Thickness Measurements, B – CSR Vessels (1 July 2013)

Reference is made to the thickness measurements report:

1 <i>Position of substantially Corroded Tanks/Areas or Areas with deep pitting</i>	$t_m - t_{ren}$ (mm)	2 <i>Corrosion pattern</i>	<i>Remarks: e.g., Ref. attached sketches</i>

Remarks

- 1 Substantial corrosion, an extent of corrosion such that the assessment of the corrosion pattern indicates a measured thickness between $t_{ren} + 0.5$ mm and t_{ren} .
- 2 P = Pitting
 C = Corrosion in General
 Areas with deep pitting assessed according to 7-A-4/35 are to be recorded in this column.

Tank Protection

<i>1</i> Tank Nos.	<i>2</i> Tank protection	<i>3</i> Coating condition	Remarks

Remarks

- 1 All segregated ballast tanks and combined cargo/ballast tanks to be listed.
- 2 (1 July 2006) C = Coating NP = No Protection
- 3 (1 July 2006) Coating condition according to the following standard.
 - GOOD** condition with only minor spot rusting.
 - FAIR** condition with local breakdown at edges of stiffeners and weld connections and/or light rusting over 20% or more of areas under consideration, but less than as defined for POOR condition.
 - POOR** condition with general breakdown of coating over 20% or more of areas or hard scale at 10% or more of areas under consideration.

If coating condition less than "GOOD" is given, extended Annual Surveys are to be introduced. This is to be noted in part H) of the Condition Evaluation Report.

PART 7

APPENDIX

SECTION 10 Bronze and Stainless Steel Propeller Castings (2013)

Note: The requirements presented in this Appendix are applicable to the material requirements and repair of bronze and stainless steel propeller castings. Procedures for bronze and stainless steel propeller castings are addressed in two separate sections such that all the appropriate repair operations are solely contained within designated sections. Four bronze alloys and five stainless steel grades are addressed as the commonly used propeller materials. Use of other bronze alloys and stainless steels are subject to special consideration.

This Appendix supersedes the *ABS Guide for Bronze and Stainless Steel Propeller Castings (7-A-10)*, 2006 and the *ABS Guidance Manual for Bronze and Stainless Steel Propeller Castings*, 1984.

1 Bronze Propellers

1.1 Introduction

Procedures and requirements in this part of the Appendix are applicable to materials, inspection, and repairs of bronze propeller castings. Alternative procedures may be considered provided that all the supporting documents are submitted for ABS review.

1.2 Foundry Approval (2006)

See 2-3-14/3.1 of the *ABS Rules for Materials and Welding (Part 2)*.

1.3 Materials

1.3.1 Representative Bronze Alloys

Four types of commonly used bronze alloys for propeller and propeller blade castings are noted herein, and are covered in Section 2-3-14 of the *ABS Rules for Materials and Welding (Part 2)*. Bronze alloys other than those listed below are subject to special approval.

1.3.2 Chemical Composition

The chemical compositions of the four representative bronze alloys are shown below.

<i>Chemical Composition, In Percent *</i>				
<i>* Note: Single values are maxima, unless otherwise noted</i>				
	<i>Type 2 Mn Bronze</i>	<i>Type 3 NiMn Bronze</i>	<i>Type 4 NiAl Bronze</i>	<i>Type 5 MnNiAl Bronze</i>
Copper	55 to 60	53.5 to 57	78 min	71 min
Zinc	Remainder	Remainder	-	-
Manganese	1.5	2.5 to 4.0	3.5	11.0 to 14.0
Aluminum	0.5 to 1.5	2.0	8.5 to 11.0	7.0 to 8.5
Nickel	0.5	2.5 to 4.0	3.0 to 5.5	1.5 to 3.0
Iron	0.4 to 2.0	1.0 to 2.5	3.0 to 5.0	2.0 to 4.0
Tin	1.00	1.00	-	-
Lead	0.40	0.20	0.03	0.03
Silicon	-	-	-	0.10
Total Others	-	-	0.50	0.50

1.3.2(a) *Zinc Equivalent.* The amount of aluminum and zinc equivalent exert a major influence on the weldability of Mn bronze Type 2 and NiMn bronze Type 3. The chemical compositions of Type 2 and Type 3 alloys are to be so controlled that the zinc equivalent, based on the following equation, does not exceed 45.0%.

$$\% \text{ zinc equivalent} = 100 - \left(\frac{100 \times \% \text{ Copper}}{100 + A} \right)$$

where A is the algebraic sum of the following zinc replacement factors:

Tin	= + 1.0 × % Sn	Iron	= - 0.1 × % Fe
Aluminum	= + 5.0 × % Al	Lead	= 0.0
Manganese	= - 0.5 × % Mn	Nickel	= - 2.3 × % Ni

When the alpha content of a Mn Bronze or NiMn bronze specimen taken from an area which is to be repaired by welding or from the end of the acceptance test bar is determined by microscopic measurement to be 20% or more, the foregoing zinc equivalent requirement will be waived.

1.3.3 Tensile Properties

The metal represented by the test specimens machined from separately cast test coupons is to conform to the following minimum tensile properties. Separately cast test coupons, as shown in 2-3-14/Figure 1 of the *ABS Rules for Materials and Welding (Part 2)*, may be used.

<i>Tensile Properties of Separately Cast Coupons^(1,2)</i>			
Type	Tensile Strength <i>N/mm² (kg/mm², psi)</i>	Yield Strength ⁽³⁾ <i>N/mm² (kg/mm², psi)</i>	Elongation ⁽⁴⁾ <i>in percent</i>
2	450 (46, 65,000)	175 (18, 25,000)	20
3	515 (53, 75,000)	220 (22.5, 32,000)	18
4	590 (60, 86,000)	245 (25, 36,000)	16
5	630 (64, 91,000)	275 (28, 40,000)	20

Notes:

- 1 These properties are generally not representative of the tensile properties of the propeller casting itself, which could be substantially lower than that of a separately cast test coupon.
- 2 Tensile requirements of integrally cast test coupons are to be specially approved.
- 3 Yield point to be determined in accordance with 2-3-1/13.3 of the *ABS Rules for Materials and Welding (Part 2)*.
- 4 See *ABS Rules for Materials and Welding* 2-1-1/Figure 2, "Round Specimen".

1.3.4 Surface Quality

All castings are to be inspected for surface defects. Inspections are to be conducted in accordance with 7-A-10/1.5.

1.3.5 Stress Corrosion Cracking

Mn bronze and NiMn bronze propellers are susceptible to a form of failure known as stress corrosion cracking. Propellers made of these alloys are to be stress relieved after they are repaired to reduce any residual stresses to safe levels before the propellers are placed in service. It is not necessary to stress relieve new castings made of these alloys which have been allowed to cool slowly in the mold unless it is found necessary to subsequently perform some welding, straightening or repitching. Since NiAl bronze is practically immune to stress corrosion cracking in propeller applications, stress relieving treatments are not usually necessary.

1.3.6 Embrittlement or Hot Shortness

Certain bronze alloys may exhibit embrittlement or hot shortness when exposed to or hot worked within particular temperature ranges. Hot working of NiAl bronze at temperatures within the range 300-500°C (570-930°F) is to be avoided. Hot working of MnNiAl bronze at temperatures within the range 260-480°C (500-900°F) or exposure of MnNiAl bronze for prolonged periods to temperatures within the range 350-565°C (660-1050°F) is to be avoided, unless the manufacturer indicates that this precaution is not applicable.

1.3.7 Marking of Propellers

1.3.7(a) New Propellers. The manufacturer's name and other appropriate identification markings are to be stamped in such location as to be discernible after finishing and assembly. Propellers are to be stamped on the hub between the blades and preferably in line with the filling plugs, if present. For separately cast blades, a marking location inside the flange area is preferred. In addition, Type 2, 3, 4 and 5 castings are to be stamped **AB/2**, **AB/3**, **AB/4**, or **AB/5** respectively, to indicate satisfactory compliance with Rule requirements. Bronze propellers and separately cast blades produced to specifications other than the alloys covered herein are to be stamped **AB/S**, followed by an identifying material specification.

1.3.7(b) Repaired Propellers. Repaired propellers are to be marked at appropriate locations (preferably adjacent to the existing markings), as per 7-A-10/1.3.7(a), to indicate that a repair has been conducted. These provisions relative to marking are not applicable to repairs normally accomplished in the manufacture of a new propeller. The marking and information to be stamped are as follows:

RECON followed by stamping which indicates the type of repair: e.g., **W** for welding repair, **S** for straightening repair, **RP** for repitching.

Surveyor's Identifying Number

Report Number

Date

Diameter

Pitch

1.3.8 Manufacturer's Certificate (2006)

For each propeller, the manufacturer is to supply to the Surveyor a certificate containing the following details:

- Purchaser and order number
- Shipbuilding project number, if known
- Description of the casting with drawing number
- Diameter, number of blades, pitch, direction of turning
- Grade of alloy and chemical composition of each heat
- Heat or casting number
- Final weight
- Results of nondestructive tests and details of test procedure where applicable
- Portion of alpha-structure for Types 2 and 3 alloys
- Results of mechanical tests
- Casting identification number
- Skew angle for high skew propellers
- Details of weld repairs including location, or by reference to the sketches required (see 7-A-10/1.5.4).

1.5 Inspection

1.5.1 New Propeller Inspection (2013)

The surface of the finished propeller is to be inspected for defects. A visual examination of the entire surface, including the blade, the fillet and the hub, is to be conducted. A dye penetrant examination of Zone A (see 7-A-10/1.5.5) is to be conducted for all propellers over 2 m (78 in.) in diameter. In addition, inspection of all suspect areas and weld repairs at the foundry, as well as random inspection of other areas are to be conducted by the dye penetrant method to the satisfaction of the Surveyor. The acceptance criteria for surface inspection of bronze propellers are shown in 7-A-10/Table 1.

1.5.2 Dimensions, Dimensional and Geometrical Tolerances (2006)

1.5.2(a) (1 July 2014) The dimensions and dimensional and geometrical tolerances are governed by the data contained in the approval drawings or order documents. These are to be submitted to the Surveyor at the time of the test. The accuracy and verification of the dimensions and weight are the responsibility of the manufacturer, and must be confirmed by an attending surveyor.

1.5.2(b) Static balancing is to be carried out on all propellers in accordance with the approved drawing. Dynamic balancing is necessary for propellers running above 500 rpm.

1.5.3 Repair Inspection

For propeller repairs, nondestructive inspection of the propeller surfaces is to be conducted, to the extent indicated below, prior to welding (if applicable) and after repair.

1.5.3(a) Inspection prior to welding. The area prepared for welding is to be inspected using dye penetrant to verify the complete removal of defects. In addition, other suspect areas of the propeller are to be inspected to the satisfaction of the Surveyor. As a minimum, random inspection of the other blades and the hub area is to be conducted.

1.5.3(b) Final Inspection After Repair. The completed repair and any suspect areas in the repair vicinity are to be inspected using dye penetrant. The acceptance criteria for surface inspection are indicated in 7-A-10/Table 1

1.5.4 Documentation of Defects and Inspections (2006)

All defects requiring welding repair are to be documented, preferably on drawings or special sketches showing their dimensions and locations. Furthermore, the inspection procedure is to be reported. The documentation is to be presented to the Surveyor prior to any weld repair.

1.5.5 Definition of Skew, Severity Zones (2006)

1.5.5(a) Definition of Skew. The skew of a propeller is defined as follows:

The maximum skew angle of a propeller blade is defined as the angle, in projected view of the blade, between a line drawn through the blade tip and the shaft centerline and a second line through the shaft centerline that acts as a tangent to the locus of the midpoints of the helical blade section. See 7-A-10/Figure 1. High skew propellers have a skew angle greater than 25°; low skew propellers, a skew angle of up to 25°.

FIGURE 1
Definition of Skew Angle (2006)

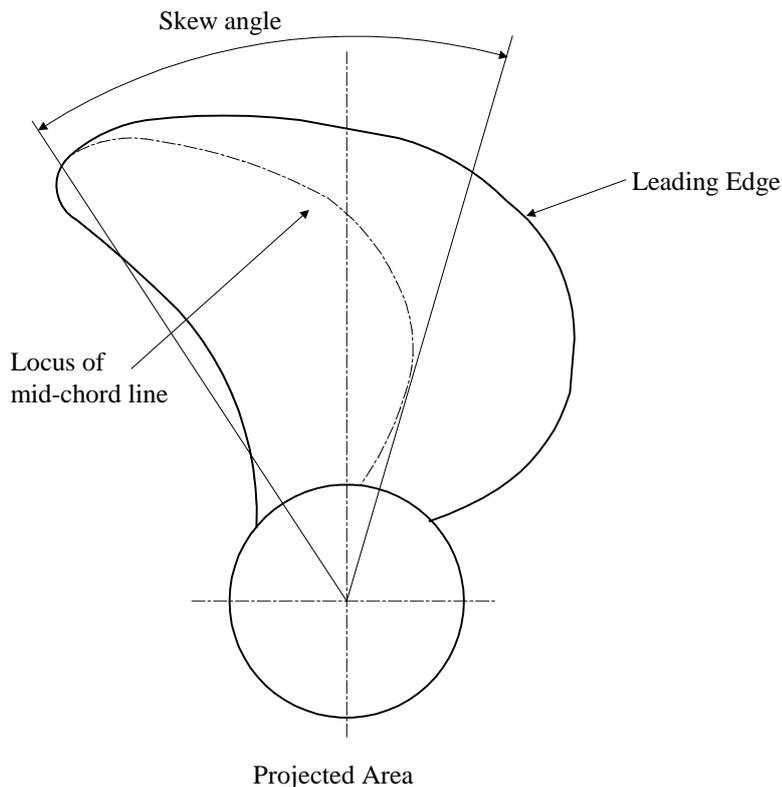

1.5.5(b) *Severity Zones (2013)*. In order to relate the degree of inspection to the criticality of defects in propeller blades and to help reduce the risk of failure by fatigue cracking after repair, propeller blades are divided into the three zones designated A, B and C. All welding procedures for bronze propellers are to be reviewed by ABS Materials Department irrespective of the zone of repair.

Zone A is the region carrying the highest operating stresses and which, therefore, requires the highest degree of inspection. Generally, the blade thicknesses are greatest in this area, giving the greatest degree of restraint in repair welds. This in turn leads to the highest residual stresses in and around any repair welds. High residual tensile stresses frequently lead to fatigue cracking during subsequent service so that relief of these stresses by heat treatment is essential for any welds made in this zone. Welding is generally not permitted in zone A and will only be allowed after special consideration by ABS. Every effort is to be made to rectify a propeller that is either defective or damaged in this area without recourse to welding even to the extent of reducing scantlings, if this is acceptable. If a repair using welding is agreed, post-weld stress relief heat treatment is mandatory except for NiAl bronze (Type 4); see 7-A-10/1.7.4.

Zone B is a region where the operation stresses may be high. Welding in Zone B is to be avoided. Special consideration may be given provided that the complete details of the defect/damage and the intended repair procedures are submitted for ABS approval.

Zone C is a region in which the operation stresses are low and where the blade thicknesses are relatively small so that repair welding is safer and, if made in accordance with an approved procedure, is freely permitted.

- i) *Low-skew propellers (2012).* Zone A is in the area on the pressure side of the blade, from and including the fillet to $0.4R$ and bounded on either side by lines at a distance 0.15 times the cord length C_R from the leading edge and 0.2 times C_R from the trailing edge, respectively (see 7-A-10/Figure 2). Where the hub radius (R_B) exceeds $0.27R$, the other boundary of zone A is to be increased to $1.5R_B$.

Zone A also includes the parts of the separate cast propeller hub that lie in the area of the windows as described in 7-A-10/Figure 4 and the flange and fillet area of controllable pitch and built-up propeller blades as described in 7-A-10/Figure 5.

Zone B is on the pressure side of the remaining area up to $0.7R$ and on the suction side, the area from the fillet to $0.7R$ (see 7-A-10/Figure 2).

Zone C is the area outside $0.7R$ on both sides of the blade. It also includes all surfaces of the hub of a monobloc propeller and all the surfaces of the hub of a controllable pitch propeller other than those designated Zone A above.

- ii) *High-skew propellers.* Zone A is the area on the pressure face contained within the blade root-fillet and a line running from the junction of the leading edge with the root fillet to the trailing edge at $0.9R$ and passing through the mid-point of the blade chord at $0.7R$ and a point situated at 0.3 of the chord length from the leading edge at $0.4R$. It also includes an area along the training edge on the suction side of the blade from the root to $0.9R$ and with its inner boundary at 0.15 of the chord lengths from the trailing edge.

Zone B constitutes the whole of the remaining blade surfaces.

Zones A and B are illustrated in 7-A-10/Figure 3.

FIGURE 2
Severity Zones for Integrally-cast, Low Skew Propellers (2006)

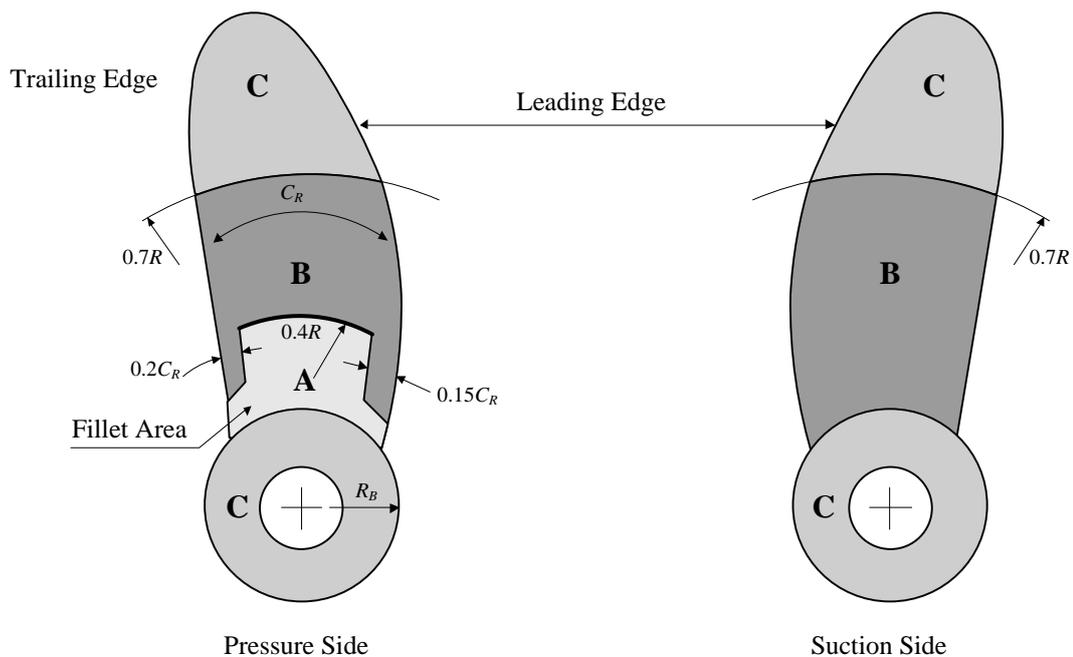

FIGURE 3
Severity Zones in Blades with Skew Angles Greater than 25° (2006)

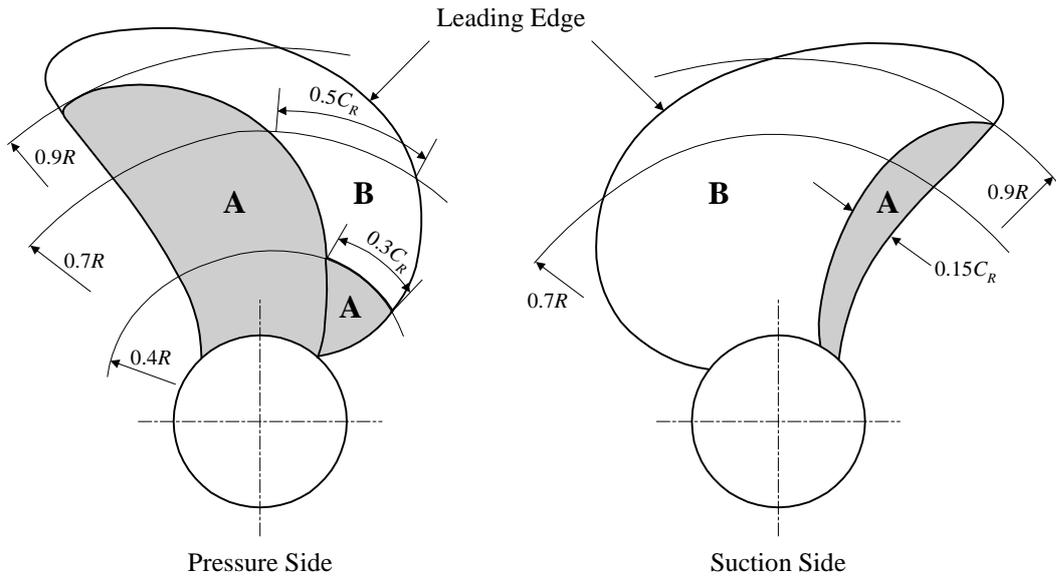

FIGURE 4
Severity Zones for Controllable Pitch Propeller Boss (2006)

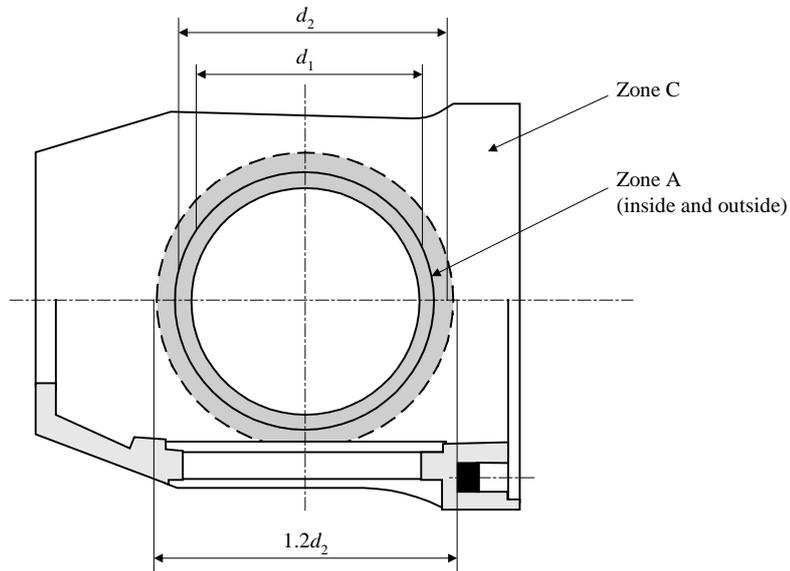
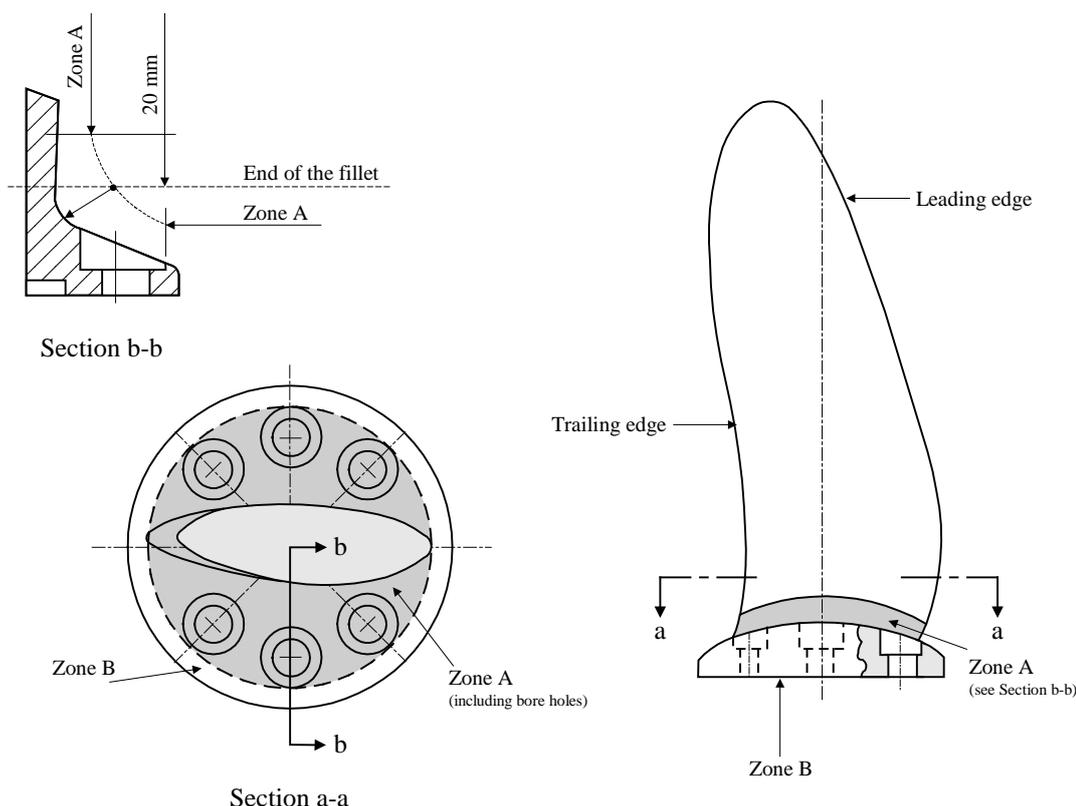

FIGURE 5
Severity Zones for Controllable Pitch and Built-up Propeller Blades (2006)



Note: The remaining surface of the propeller blade is to be divided into the severity zones as given for solid cast propellers (see 7-A-10/Figure 2 and 7-A-10/Figure 3).

1.7 Welding

1.7.1 General (2012)

(2006) In general, repairs are to be carried out by mechanical means (e.g. by grinding, chipping or milling). Welding may be applied subject to the agreement of the Surveyor. After milling or chipping, grinding is to be carried out for such defects that are not to be welded. Grinding is to be done in such a manner that the contour of the ground depression is as smooth as possible in order to avoid stress concentrations or to minimize cavitation corrosion.

Major and Minor Welding Repairs: Minor welding repairs include the repair of edges on the outer $\frac{1}{3}$ of the propeller diameter and in general are to be limited to the repair of sections under 32 mm ($1\frac{1}{4}$ in.) thick. All other repairs are considered to be major repairs. Welding repair for the sake of appearance only is to be avoided. Defects not over 3.2 mm ($\frac{1}{8}$ in.) deep are to be dimpled.

1.7.1(a) Welding repair to Zone A (2006). No welding in way of Zone A of a blade is to be undertaken without prior approval by the Surveyor and the ABS Materials Department. Zone A is defined in 7-A-10/1.5.5. Repairs in Zone A are to be made by mechanical means or by arc welding.

1.7.1(b) Welding repair to Zone B (2006). Defects less than $d_p = (t/40)$ mm ($t = \text{min. local thickness in mm according to the Rules}$) or 2 mm (whichever is greatest) below minimum local thickness according to the Rules are to be removed by grinding. Zone B is defined in 7-A-10/1.5.5. Welding repair for the sake of appearance only is to be avoided; defects not over 3.2 mm ($\frac{1}{8}$ in.) deep are to be dimpled.

1.7.1(c) *Welding repair to Zone C (2006)*. In Zone C, repair welds are generally permitted. Zone C is defined in 7-A-10/1.5.5

1.7.1(d) *Preparation for Welding Repair*. Defects are to be removed to sound metal prior to welding and the area to be weld repaired is to be appropriately prepared (see 7-A-10/Figures 6 and 7). For blade tip replacement, appropriate grooves such as shown in 7-A-10/Figure 8 are to be used.

1.7.1(e) *Inspection Prior to Welding*. Prior to welding, inspection is to be conducted in accordance with 7-A-10/1.5.3(a).

1.7.1(f) *Welding Processes, Procedures and Filler Metals*. The processes, filler metals and procedures listed in 7-A-10/Tables 2 through 5 are required for the repair of bronze propellers of the alloy types indicated. Shielded metal arc welding, gas metal arc welding and gas tungsten arc welding are satisfactory for all major and minor repairs on all types of propellers. Oxyfuel gas welding is permitted on Mn bronze and NiMn bronze, but is limited to the repair of edges on the outer one third of the propeller radius and, in general, to sections under 32 mm (1 $\frac{1}{4}$ in.) thick.

- i) *Peening*. Usually, the first weld layer is not to be peened. The last layer is not to be peened unless the weld is to be subsequently stress relieved. Peening of the intermediate weld layers is optional; heavy peening is to be avoided.
- ii) *Solder or Silver Brazing*. The repair of defects by means of solders or silver brazing alloys is not permitted.
- iii) *Position of Welding*. When practicable, welding is to be done in the flat (downhand) position.
- iv) *(2006) Draft-free shop*. All welding work is to be carried out preferably in the shop, free from drafts and influence of the weather.

1.7.2 Welding Qualification (Procedure and Welder)

1.7.2(a) *General (2009)*. Welding qualification tests are to be made at each foundry or repair facility where it is intended to repair propellers by welding. The welding qualification test is to be made in accordance with 7-A-10/Figure 9 and with the same process, equipment, electrodes, preheat and stress relief as would normally be used in making the repair welds; and is to be made with cast bronze plates of 30 mm (1 $\frac{1}{4}$ in.) minimum thickness and of a chemical composition similar to the propeller materials to be repair welded. Qualification testing is to be conducted for each position in which welding is to be done.

1.7.2(b) *Procedure Qualification (2006)*. Prior to sectioning, the test assembly is to be visually and liquid penetrant tested. No cracks are permitted. Two reduced-section tension specimens and four macroetch specimens are to be prepared in accordance with 7-A-10/Figures 9 and 10. The tested specimens are to meet the acceptance criteria as per 7-A-10/Figures 9 and 10.

1.7.2(c) *Welder Qualification*. Four macroetch specimens are to be prepared in accordance with 7-A-10/Figure 9. The tested specimens are to meet the acceptance criteria as per 7-A-10/Figure 9.

1.7.3 Welding Preheat and Interpass Procedures and Temperatures

1.7.3(a) *Preheat and Interpass Procedures*. The preheat and interpass temperatures are to extend entirely through the section being repaired to a distance of about 300 mm (12 in.) on all sides of the repair area so that a maximum temperature gradient of about 55°C per 300 mm (100°F per ft) can be maintained in the surrounding area. Heating is to be accomplished by means of soft gas (natural gas, LPG) torches or strip heaters or by means of moving oxyacetylene torches used with proper precaution to avoid local overheating. The temperature is to be checked at frequent intervals by means of temperature indicating crayons or contact pyrometers. The preheat and interpass temperatures are to be maintained throughout the entire welding operation. Adequate support to minimize distortion is to be provided during the preheat and welding operations.

1.7.3(b) *Preheat and Interpass Temperature Ranges*. The preheat and interpass temperature ranges listed in 7-A-10/Tables 2 through 5 are required for the various welding processes and alloys.

1.7.4 Stress Relief

1.7.4(a) General (2006). Repairs (welding, straightening and repitching) made on Mn bronze, NiMn bronze and MnNiAl bronze propellers are to be stress relieved within the appropriate temperature range shown in 7-A-10/Tables 2, 3, 5 and 6. Although the stress relieving treatment is usually carried out immediately after welding, no harm is to be expected if the weld area is first allowed to cool to room temperature and is then given a stress relieving treatment as soon as practicable to reduce the possibility of postweld cracking. NiAl bronze propeller repairs do not require stress relieving treatment, as shown in 7-A-10/Tables 4 and 6. Stress relief heat treatment of NiAl bronze propeller castings may be required after major repairs in Zone B (and specially approved welding in Zone A) or if a welding consumable susceptible to stress corrosion cracking is used. In such cases, the propeller is to be either stress relief heat treated in the temperature range of 450-500°C or annealed in the temperature range of 650-800°C depending on the extent of repair. See 7-A-10/Table 4.

1.7.4(b) Furnace Stress Relief. Where possible, furnace stress relief is to be carried out after repairs, especially for heavy sections such as the hub or the fillet areas. This may be done either by heating the entire propeller or by heating a complete section containing the areas to be stress relieved in a furnace or oven. Furnace stress relief of an entire propeller is to be effected by slow uniform heating to a temperature in the appropriate temperature range, and the soaking time at temperature is to be a minimum of 6 hours. Where only a section of the propeller is furnace stress relieved, the holding time is to be at least 20 minutes per 25.4 mm (1 in.) of section measured at the thickest portion of the repair area. The heating and cooling of the propeller or propeller section in the furnace are to be slow enough so that a maximum temperature differential of 55°C (100°F) is not exceeded anywhere on the propeller.

1.7.4(c) Local Stress Relief. In order to effect a suitable local stress relief, a band, as described below, is to be slowly heated to the stress relieving temperature so that a temperature gradient of 55°C per 300 mm (100°F per ft) is not exceeded. Heating is to be accomplished by means of soft gas torches or strip heaters or by means of moving oxyacetylene torches used with proper precaution to avoid local overheating. The soaking time at temperature is to be at least 20 minutes per 25.4 mm (1 in.) of thickness at the repair area. In the case of a weld repair, the weld thickness is to be used to determine the soaking time, but in no case is the soaking time to be less than one hour. For Mn bronze, NiMn bronze and MnNiAl bronze, the section is to be slowly cooled so that a temperature gradient of 55°C per 300 mm (100°F per ft) is not exceeded. Slow cooling from the local stress relieving temperature may be accomplished by wrapping or covering with insulating blankets. For a local stress relief, the band is to measure approximately 300 mm (12 in.) on all sides of the repair and is to extend through the entire thickness of the blade. In addition, for a local stress relief of a major repair, the band is to extend across the entire width of the blade.

1.7.4(d) Distortion Control. Adequate support to minimize distortion is to be provided during any of the above mentioned stress relieving treatments.

1.7.5 Burn-in (or Hot Flow Process)

1.7.5(a) General. The burn-in (or hot flow) process is considered satisfactory for major repairs on Mn bronze or NiMn bronze propellers. Burn-ins are to extend completely through the section being repaired; i.e., not into a partly chipped out section, because it is necessary to examine the underside of the burn-in sections to be sure of proper fusion. For this reason and because of excessive distortion, burn-ins are not frequently used for making repairs to propeller hubs.

1.7.5(b) Preheat for Burn-in Repairs. A preheat in the 260°C (500°F) to 315°C (600°F) temperature range is to be used.

1.7.5(c) Stress Relief of Burn-in Repairs. A stress-relief treatment in the temperature range specified below, followed by slow cooling, is necessary for all burn-in repairs:

Mn Bronze: 315°C (600°F) to 425°C (800°F)

NiMn Bronze: 370°C (700°F) to 425°C (800°F)

1.7.6 Inspection After Welding

After welding repair operations and stress relief (if applicable) have been effected, the propeller is to be inspected in accordance with 7-A-10/1.5.3(b).

1.7.7 Marking

After welding repair operations and final inspection have been effected, the propeller is to be marked in accordance with 7-A-10/1.3.7(b).

1.9 Straightening

1.9.1 Major and Minor Straightening Repairs.

Minor straightening repairs include the repair of edges on the outer $\frac{1}{3}$ of the propeller diameter and, in general, are to be limited to the repair of sections under 32 mm (1 $\frac{1}{4}$ in.) thick. All other repairs, including repairs to the critical area of high skew propellers, are considered to be major repairs.

1.9.2 Straightening Procedures

The straightening procedures given in 7-A-10/Table 6 are to be followed in making repairs to the types of propeller alloys listed below:

1.9.2(a) Mn Bronze, NiMn Bronze and MnNiAl Bronze. For Mn bronze, NiMn bronze and MnNiAl bronze, a stress relieving treatment in accordance with 7-A-10/1.7.4 is necessary.

1.9.2(b) NiAl Bronze. NiAl bronze propellers do not require stress relieving treatments after straightening.

1.9.3 Cold Straightening

Cold straightening [straightening at a temperature below 205°C (400°F)] by means of dynamic loads is to be used only in making minor straightening repairs at the tips or the thin edges of Mn bronze, NiMn bronze or NiAl bronze blades. Cold straightening by means of pressure loads is to be used in accordance with 7-A-10/Table 6. In the case of Mn Bronze and NiMn bronze propellers, cold straightening is to be followed by a suitable stress relief treatment, as per 7-A-10/1.7.4 and as shown in 7-A-10/Table 6.

1.9.4 Hot Straightening

Hot straightening by means of dynamic loads and pressure loads may be used for all straightening repairs. The portion of the propeller which is being straightened is to be kept within the required temperature range during the course of the repair by means of soft gas torches or strip heaters or by means of moving oxyacetylene torches used with proper precaution to avoid local overheating. A generous area surrounding the section to be straightened is to be heated through its entire thickness to the required temperature. After the straightening operation has been completed, the propeller may be slowly cooled to room temperature by wrapping or covering with insulating blankets, or by other suitable means. Mn bronze, NiMn bronze and MnNiAl bronze propellers are to be given a suitable stress relief treatment as soon as practical after the straightening operation, as per 7-A-10/1.7.4 and as shown in 7-A-10/Table 6.

1.9.5 Inspection After Straightening

After straightening repair operations and stress relief (if applicable) have been effected, the propeller is to be inspected in accordance with 7-A-10/1.5.3(b).

1.9.6 Marking

After straightening repair operations and final inspection have been effected, the propeller is to be marked in accordance with 7-A-10/1.3.7(b).

1.11 Repitching

1.11.1 General

Repitching of a propeller is subject to special approval unless the change in pitch, measured at 0.7 radius, is less than 5% and the repitching is accomplished with uniform deformation and outside the blade 0.4 radius. No repitching of a propeller that has already undergone repitching is to be undertaken without special approval unless the cumulative absolute change in pitch is less than 5% and the above provisions are complied with.

1.11.2 Repitching by Pressure Loading

Repitching by means of slowly applied uniform loads may be carried out at the temperature ranges indicated in 7-A-10/Table 6. Repitching by means of dynamic loading is not allowed. The portion of the propeller which is being repitched is to be kept within the required temperature range during the course of the repitching by means of soft gas torches or strip heaters or by means of moving oxyacetylene torches used with proper precaution to avoid local overheating. A generous area surrounding the section to be repitched is to be heated through its entire thickness to the required temperature. After the repitching has been completed, the propeller may be slowly cooled to room temperature by wrapping or covering with insulating blankets, or by other suitable means. Mn bronze, NiMn bronze and MnNiAl bronze propellers are to be given a suitable stress relief treatment as soon as practical after the repitching operation, as indicated in 7-A-10/1.7.4 and in 7-A-10/Table 6.

1.11.3 Inspection After Repitching

After repitching operations and stress relief (if applicable) have been effected, the propeller is to be inspected in accordance with 7-A-10/1.5.3(b).

1.11.4 Marking

After repitching operations and final inspection have been effected, the propeller is to be marked in accordance with 7-A-10/1.3.7(b).

TABLE 1
Acceptance Criteria for Surface Inspection of
Bronze and Stainless Steel Propellers (2006)

Location of Discontinuity	Type of Discontinuity ⁽¹⁾	Max. Acceptable Discontinuity in mm (in.)	Discontinuity Acceptance Standards		Allowable Areas of Concentration
			Max. Number ⁽²⁾ 150 mm × 150 mm (6 in. × 6 in.) Area of Concentration ^(3,4)	Min. Spacing Between Aligned Discontinuities ^(5,6)	
Zone A	Non-linear	3.2 (1/8)	10	D	5% of propeller surface area with distribution by a max. of 5% for each blade surface
	Linear	3.2 (1/8)	3	4D	
Remaining surfaces of the blade	Non-linear	3.2 (1/8)	20	D	
	Linear	6.4 (1/4)	8	4D	
Propeller hub	Non-linear	6.4 (1/4)	15	D	
	Linear	9.5 (3/8)	6	4D or 25.4 mm (1 in.) whichever is less	
Weldments	Non-linear	1.6 (1/16)	12	4D	5% of total weld area
	Linear	0 (0)	0	---	

Notes:

- 1 A linear discontinuity is one in which the length is greater than three (3) times the width. For dimensional purposes, the size of the actual discontinuity, not the size of the indication, is to be used.
- 2 The total number of non-linear discontinuities may be increased to the combined total, or part thereof, represented by the absence of linear discontinuities.
- 3 Randomly dispersed casting discontinuities whose major dimensions are 1.6 mm (1/16 in.) or less are not to be counted in determining total number of discontinuities within an area of concentration.
- 4 More than six (6) discontinuities whose major dimensions are greater than 2.4 mm (3/32 in.) in any 150 mm × 150 mm (6 in. × 6 in.) area of the propeller surface constitute an area of concentration. Each area of concentration is to be separated from an adjacent area of concentration by a minimum of 455 mm (18 in.).
- 5 Minimum spacing is the distance separating two adjacent discontinuities in terms of the major dimension of the larger discontinuity (D). Aligned non-linear discontinuities are to consist of four or more discontinuities in a line; aligned linear discontinuities are to consist of two or more discontinuities whose major dimensions are oriented in a line. However, when the total length of the aligned discontinuities does not exceed the maximum length permitted for a single discontinuity, these aligned discontinuities are to be considered as one discontinuity, and are not to be cause for rejection.
- 6 When the major dimension of clustered discontinuities does not exceed the maximum size permitted for a single discontinuity, these clustered discontinuities are to be considered as one discontinuity, and are not to be cause for rejection. Scattered discontinuities, separated from the cluster by 3.2 mm (1/8 in.) or more, are not to be considered as part of the cluster.

TABLE 2
Parameters for Welding of Type 2, Mn Bronze

<i>Filler Metal ⁽¹⁾</i>	<i>Shielded Metal Arc Welding</i>	<i>Gas Metal and Gas Tungsten Arc Welding</i>	<i>Oxyfuel Gas Welding ⁽²⁾</i>
AWS Specification	A5.6	A5.7	A5.27
AWS Classification	E CuAl-A2 E CuNiAl	ER CuAl-A2 ER CuNiAl	R CuZnB R CuZnC
<i>Temperature range in °C (°F)</i>			
Preheat-interpass range	260-425 (500-800)	150-425 (300-800)	315-425 (600-800)
Stress relief	315-425 (600-800)	315-425 (600-800)	315-425 (600-800)

Notes:

- 1 Equivalent specifications may be used.
- 2 Permitted only for minor repairs, as defined in 7-A-10/1.7.1(b).

TABLE 3
Parameters for Welding of Type 3, NiMn Bronze

<i>Filler Metal ⁽¹⁾</i>	<i>Shielded Metal Arc Welding</i>	<i>Gas Metal and Gas Tungsten Arc Welding</i>	<i>Oxy fuel Gas Welding ⁽²⁾</i>
AWS Specification	A5.6	A5.7	A5.27
AWS Classification	E CuAl-A2 E CuNiAl	ER CuAl-A2 ER CuNiAl	R CuZnB R CuZnC
<i>Temperature range in °C (°F)</i>			
Preheat-interpass range	260-425 (500-800)	150-425 (300-800)	315-425 (600-800)
Stress relief	370-425 (700-800)	370-425 (700-800)	370-425 (700-800)

Notes:

- 1 Equivalent specifications may be used.
- 2 Permitted only for minor repairs, as defined in paragraph 7-A-10/1.7.1(b).

TABLE 4
Parameters for Welding of Type 4, NiAl Bronze

<i>Filler Metal ⁽¹⁾</i>	<i>Shielded Metal Arc Welding</i>	<i>Gas Metal and Gas Tungsten Arc Welding</i>
AWS Specification	A5.6	A5.7
AWS Classification	E CuAl-A2 E CuNiAl ⁽²⁾	ER CuAl-A2 ER CuNiAl ⁽²⁾
<i>Temperature range in °C (°F)</i>		
Preheat-interpass range	40-205 (100-400)	40-205 (100-400)
Stress relief	See 7-A-10/1.7.4(a)	See 7-A-10/1.7.4(a)

Notes:

- 1 Equivalent specifications may be used.
- 2 EcuNiAl/ERCuNiAl are preferred.

TABLE 5
Parameters for Welding of Type 5, MnNiAl Bronze

<i>Filler Metal ⁽¹⁾</i>	<i>Shielded Metal Arc Welding</i>	<i>Gas Metal and Gas Tungsten Arc Welding</i>
AWS Specification	A5.6	A5.7
AWS Classification	E CuMnNiAl	ER CuMnNiAl
<i>Temperature range in °C (°F)</i>		
Preheat-interpass range	40-205 (100-400)	40-205 (100-400)
Stress relief ⁽²⁾	565-649 (1050-1200)	565-649 (1050-1200)

Notes:

- 1 Equivalent specifications may be used.
- 2 When a minor repair, as defined in 7-A-10/1.7.1(b), involves a limited area, stress relief may be waived at the discretion of the Surveyor.

TABLE 6
Temperatures for Straightening and Repitching Bronze Propellers

	<i>Type 2 Mn Bronze</i>	<i>Type 3 NiMn Bronze</i>	<i>Type 4 NiAl Bronze</i>	<i>Type 5 MnNiAl Bronze</i>
Temperatures for Minor Straightening in °C (°F)				
Cold				
Dynamic loading	Ambient to 205 (Ambient to 400)	Ambient to 205 (Ambient to 400)	Ambient to 205 (Ambient to 400)	Not Recommended
Hot				
Dynamic loading	595-760 (1100-1400)	595-760 (1100-1400)	760-955 (1400-1750)	790-870 (1450-1600)
Cold				
Pressure loading	Any temperature	Any temperature	Ambient to 205 (Ambient to 400)	Not Recommended
Hot				
Pressure loading	Any temperature	Any temperature	760-955 (1400-1750)	705-815 (1300-1500)
Temperatures for Major Straightening in °C (°F)				
Dynamic loading	595-760 (1100-1400)	595-760 (1100-1400)	760-955 (1400-1750)	790-870 (1450-1600)
Pressure loading	Any temperature	Any temperature	760-955 (1400-1750)	705-815 (1300-1500)
Temperatures for Repitching, in °C (°F)				
Pressure loading	Any temperature	Any temperature	760-955 (1400-1750)	705-815 (1300-1500)
Temperatures for Stress Relief After Straightening or Repitching, in °C (°F)	315-425 (600-800)	370-425 (700-800)	None	565-649 (1050-1200)

3 Stainless Steel Propellers

3.1 Introduction

The procedures presented in this Appendix are applicable to the material requirement, inspection, and the repair of stainless steel propeller castings. Other proposals of repair procedures may be considered provided that all the supporting documents are to be submitted for ABS review.

3.2 Foundry Approval (2006)

See 2-3-15/1.3.

3.3 Materials

3.3.1 Representative Stainless Steel Alloys (2006)

Five stainless steel alloys representative of those used for propeller and propeller blade castings are noted herein; grade CF-3 stainless steel is covered in Section 2-3-15 of the *ABS Rules for Materials and Welding (Part 2)*. Stainless steel alloys other than grade CF-3 are subject to special approval. Foundry approval is required for all alloy grades. See 2-3-15/1.

3.3.2 Chemical Composition (2006)

The chemical compositions of the five representative stainless steel alloys are shown below.

<i>Chemical Composition, in Percent *</i>					
<i>* Note: Single values are maxima</i>					
	<i>Grade CF-3</i>	<i>Grade CF-8</i>	<i>Grade CA-6NM</i>	<i>Grade CB-6</i>	<i>Grade CA-15</i>
Carbon	0.03	0.08	0.06	0.06	0.15
Manganese	1.50	1.50	1.00	1.00	1.00
Silicon	2.00	2.00	1.00	1.00	1.50
Sulfur	0.04	0.04	0.03	0.03	0.04
Phosphorus	0.04	0.04	0.04	0.04	0.04
Chromium	17.0 to 21.0	18.0 to 21.0	11.5 to 14.0	15.5 to 17.5	11.5 to 14.0
Nickel	8.0 to 12.0	8.0 to 11.0	3.5 to 4.5	3.5 to 5.5	1.00
Molybdenum	-	-	0.40 to 1.0	0.50	0.50

3.3.3 Tensile Properties (2009)

The tensile properties of the five representative stainless steel alloys are shown below.

<i>Tensile Properties ⁽¹⁾</i>					
	<i>Grade CF-3</i>	<i>Grade CF-8</i>	<i>Grade CA-6NM</i>	<i>Grade CB-6</i>	<i>Grade CA-15</i>
Tensile Strength, in N/mm ² (kg/mm ² , psi)	485 (49, 70,000)	485 (49, 70,000)	755 (77, 110,000)	790 (81, 115,000)	620 (63, 90,000)
Yield Strength in N/mm ² (kg/mm ² , psi) (0.2% offset)	205 (21, 30,000)	205 (21, 30,000)	550 (56, 80,000)	580 (59, 85,000)	450 (46, 65,000)
Elongation, in 50 mm (2 in.), in percent	35	35	15	16	18

Note:

- (2006) Tensile properties shown are from either separately cast or integrally cast test coupons. Testing is to be in accordance with 2-3-15/9.

3.3.4 Surface Quality

All castings are to be inspected for surface defects. Inspections are to be conducted in accordance with 7-A-10/3.5.

3.3.5 Characteristics of Stainless Steel

3.3.5(a) Austenitic Stainless Steel. Austenitic stainless steels generally exhibit no magnetic response or in some instances a very weak one. Austenitic stainless steels are non-hardenable by heat treatment.

3.3.5(b) Martensitic Stainless Steel. Martensitic stainless steels exhibit a strong magnetic response and are hardenable by heat treatment.

3.3.6 Intergranular Corrosion

Intergranular corrosion is a form of material degradation which may affect austenitic stainless steel (e.g., grades CF-3, CF-8) upon exposure to certain atmospheric environments common to shipyards and foundries. Intergranular corrosion is apparent by visual or dye penetrant examination as a pattern of surface cracks or surface crazing in isolated or continuous areas of various sizes and may be present in more than one location.

3.3.7 Grinding Cracks

Improper grinding of stainless steel may produce localized overheating which can result in cracking. Localized overheating can occur due to heavy pressure and lack of movement of the grinding tool. Precautions are to be taken to avoid such conditions when grinding is used in finishing or repair.

3.3.8 Preparation for Storage

Unless they are intended for use immediately after manufacture or repair, the surfaces of propellers are to be suitably protected from the possible adverse corrosive effects of certain atmospheric environments common to shipyards and foundries.

3.3.9 Marking of Propellers

3.3.9(a) New Propellers (2006). The manufacturer's name and other appropriate identification markings are to be stamped in such location as to be discernible after finishing and assembly. Propellers are to be stamped on the hub between the blades and preferably in line with the filling plugs, if present. For separately cast blades, a marking location inside the flange area is preferred. In addition, Grade CF-3, CF-8, CA-6NM, CB-6 and CA-15 castings are to be stamped **AB/CF-3**, **AB/S/CF-8**, **AB/S/CA-6NM**, **AB/S/CB-6** and **AB/S/CA-15**, respectively. Stainless steel propellers and separately cast blades, produced to specifications other than the alloys covered herein, are to be stamped **AB/S** followed by an identifying material specification.

3.3.9(b) Repaired Propellers. Repaired propellers are to be marked at appropriate locations (preferably adjacent to the existing markings), as per 7-A-10/3.3.9(a), to indicate that a repair has been conducted. These provisions relative to marking are not applicable to repairs normally accomplished in the manufacture of a new propeller. The marking and information are to be stamped as follows:

RECON followed by stamping which indicates the type of repair; e.g., **W** for welding repair, **S** for straightening repair, **RP** for repitching.

Surveyor's Identifying Number

Report Number

Date

Diameter

Pitch

3.3.10 Manufacturer's Certificate (2006)

For each propeller, the manufacturer is to supply to the Surveyor a certificate containing the following details:

- Purchaser and order number
- Vessel identification or shipbuilding project number, if known
- Description of the casting with drawing number
- Diameter, number of blades, pitch, direction of turning
- Grade of alloy and chemical composition of each heat
- Heat or casting number
- Final mass
- Results of nondestructive tests and details of test procedure where applicable
- Results of mechanical tests
- Casting identification number
- Details of time and temperature of heat treatment
- Skew angle for high skew propellers (see 7-A-10/1.5.5)
- Details of weld repairs including location, or by reference to the sketches required (see 7-A-10/3.7.1).

3.5 Inspection

3.5.1 New Propeller Inspection (2006)

The surface of the finished propeller is to be inspected for defects. A visual examination of the entire surface, including the blade, the fillet and the hub, is to be conducted. A dye penetrant examination of the entire propeller is to be made; for the martensitic stainless steel propellers, a magnetic particle examination may be used in lieu of dye penetrant examination, provided that proper precaution to prevent arc strike is taken. In order to relate the degree of nondestructive testing to the criticality of imperfections, propeller blades are divided into three severity zones, A, B and C, as defined in 7-A-10/1.5.5. Witnessing of inspections in Zones B and C is optional. For austenitic stainless steel propellers, particular attention is to be given to detect cracking typical of intergranular corrosion. The acceptance criteria for surface inspection of stainless steel propellers are shown in 7-A-10/Table 1.

The foundry is to maintain records of inspections traceable to each casting. These records are to be reviewed by the Surveyor. The foundry is also to provide the Surveyor with a statement confirming that nondestructive tests have been carried out with satisfactory results.

Where serious doubt exists that the castings are not free from internal defects, further nondestructive inspections are to be carried out upon request of the Surveyor, (e.g., RT/UT). Acceptance criteria are then to be agreed between the manufacturer and ABS.

3.5.2 Dimensions, Dimensional and Geometrical Tolerances (2006)

3.5.2(a) Dimensions are the responsibility of the manufacturer. The report on dimensional inspection is to be handed over to the Surveyor, who may require checks to be made in his presence.

3.5.2(b) Static balancing is to be carried out on all propellers in accordance with the approved drawing. Dynamic balancing may be necessary for propellers running above 500 rpm.

3.5.3 Repair Inspection

For propeller repair, nondestructive inspection of the propeller surfaces is to be conducted, to the extent indicated below, prior to welding (if applicable) and after repair.

3.5.3(a) Inspection Prior to Welding. The area prepared for welding is to be inspected using dye penetrant or magnetic particle (if applicable) to verify the complete removal of defects. In addition, other suspect areas of the propeller are to be inspected to the satisfaction of the Surveyor. As a minimum, random inspection of the other blades and the hub area is to be conducted.

3.5.3(b) Final Inspection After Repair. The completed repair and any suspect area in the repair vicinity are to be inspected using dye penetrant or magnetic particle (if applicable). The acceptance criteria for surface inspections are indicated in 7-A-10/Table 1.

3.7 Welding

3.7.1 General

(2013) In general, repairs are to be carried out by mechanical means (e.g. by grinding or milling). The resulting grooves are to be blended into the surrounding surface so as to avoid any sharp contours. Complete elimination of the defective material is to be verified by PT. Weld repairs are to be undertaken only when they are considered to be necessary and have prior approval of the Surveyor. All weld repairs are to be documented by means of sketches or photographs showing the location and major dimensions of the grooves prepared for welding. The documentation is to be presented to the Surveyor prior to repair welding. All welding procedures for stainless steel propellers are to be reviewed by ABS materials department irrespective of the zone of repair.

(2014) *Major and Minor Welding Repairs:* Minor welding repairs include the repair of edges on the outer $\frac{1}{3}$ of the propeller diameter and in general should be limited to the repair of sections under 32 mm ($1\frac{1}{4}$ in.) thick. All other repairs are considered to be major repairs. Welding repair for the sake of appearance only is to be avoided. Defects not over 3.2 mm ($\frac{1}{8}$ in.) deep should be dimpled.

3.7.1(a) Welding repair to Zone A (2006). No welding in way of Zone A of a blade is to be undertaken without prior approval by the Surveyor and the ABS Materials Department. Zone A is defined in 7-A-10/1.5.5. Repairs in Zone A are to be made by mechanical means or by means of arc welding.

3.7.1(b) Welding repair to Zone B (2006). Defects less than $d_b = (t/40)$ mm ($t =$ min. local thickness in mm according to the Rules) or 2 mm (whichever is greatest) below minimum local thickness according to the Rules are to be removed by grinding. Zone B is defined in 7-A-10/1.5.5. Defects that are deeper may be repaired by welding subject to prior approval from the Surveyor.

3.7.1(c) Welding repair to Zone C (2006). In Zone C, repair welds are generally permitted. Zone C is defined in 7-A-10/1.5.5.

3.7.1(d) Preparation for Welding Repair. Defects are to be removed by grinding (see 7-A-10/3.3.7), chipping, plasma or carbon arc gouging or other suitable methods. If carbon arc gouging is used, grinding of the prepared groove surface is required to remove any carbon pick-up. All prepared surfaces are to be cleaned to bright metal before welding. Typical groove configurations are shown in 7-A-10/Figures 6 and 7. For blade tip replacement, a typical groove configuration is shown in 7-A-10/Figure 8.

3.7.1(e) Inspection Prior to Welding. Prior to welding, inspection is to be conducted in accordance with 7-A-10/3.5.3(a).

3.7.1(f) Welding Processes, Procedures and Filler Metals. The processes, filler metals and procedures listed in 7-A-10/Tables 7 through 10 are to be used for the repair of stainless steel propellers of the grades indicated.

- i) *Peening.* Usually, the first weld layer is not to be peened. The last layer also should usually not be peened unless the weld is to be subsequently stress relieved. Peening of the intermediate weld layers is optional.
- ii) *Soldering or Brazing.* The repair of defects by means of soldering or brazing is not permitted.

- iii) *Position of Welding.* When practicable, welding is to be done in the flat (downhand) position.
- iv) (2006) Welding is to be done under controlled conditions free from drafts and adverse weather.

3.7.1(g) *Repair of Intergranular Corrosion*

- i) *Intergranular Corrosion Not Greater than 1.6 mm (1/16 in.) in Depth.* If the intergranular corrosion is found to extend less than or equal to 1.6 mm (1/16 in.) beneath the surface of the propeller, repair may be effected by surface grinding to remove all of the affected material.
- ii) *Intergranular Corrosion Greater than 1.6 mm (1/16 in.) in Depth.* If the intergranular corrosion is found to extend more than 1.6 mm (1/16 in.) beneath the surface of the propeller, repair may be effected by welding.
- iii) *Inspection After Repair of Intergranular Corrosion.* Propellers are to be inspected after repair of intergranular corrosion in accordance with 7-A-10/3.5.2(b). Particular attention is to be given to verify that all suspect areas are examined and that all surfaces of the propeller are free from intergranular corrosion.
- iv) *Marking.* After welding repair of intergranular corrosion has been effected, the propeller is to be marked in accordance with 7-A-10/3.3.9(b).
- v) *Preparation for Storage.* Propeller surfaces are to be protected after repair of intergranular corrosion when required by 7-A-10/3.3.8.

3.7.2 Welding Qualification (Procedure and Welder)

3.7.2(a) *General (2009).* Welding qualification tests are to be made at each foundry or repair facility where it is intended to repair propellers by welding. The welding qualification test is to be made in accordance with 7-A-10/Figure 9 and with the same process, equipment, electrodes, preheat and stress relief as would normally be used in making the repair welds; and are to be made with stainless steel plates of 30 mm (1 1/4 in.) minimum thickness and of a chemical composition similar to the propeller material to be repair welded. Qualification testing is to be conducted for each position in which welding is to be done.

3.7.2(b) *Procedure Qualification (2006).* Prior to sectioning, the test assembly is to be visually and liquid penetrant tested. Imperfections are to be assessed in accordance with 7-A-10 Table 1. Two reduced-section tension specimens and four macroetch specimens are to be prepared in accordance with 7-A-10/Figures 9 and 10. The tested specimens are to meet the acceptance criteria as per 7-A-10/Figures 9 and 10.

3.7.2(c) *Welder Qualification.* Four macroetch specimens are to be prepared in accordance with 7-A-10/Figure 9. The tested specimens are to meet the acceptance criteria as per 7-A-10/Figure 9.

3.7.3 Welding Preheat and Interpass Procedures and Temperatures

3.7.3(a) *Preheat and Interpass Procedures.* The preheat and interpass temperatures are to extend entirely through the section being repaired to a distance of about 300 mm (12 in.) on all sides of the repair area so that a maximum temperature gradient of about 55°C per 300 mm (100°F per ft) can be maintained in the surrounding area. Heating is to be accomplished by means of soft gas (natural gas, LPG) torches or strip heaters or by means of moving oxyacetylene torches used with proper precaution to avoid local overheating. The temperature is to be checked at frequent intervals by means of temperature indicating crayons or contact pyrometers. The preheat and interpass temperatures are to be maintained throughout the entire welding operation. Adequate support to minimize distortion is to be provided during the preheat and welding operations.

3.7.3(b) *Preheat and Interpass Temperature Ranges.* The preheat and interpass temperature ranges listed in 7-A-10/Tables 7 through 9 are to be used for the various welding processes and alloys.

3.7.4 Cooling After Welding (2006)

The welded areas of martensitic stainless steel propellers are to be slowly cooled (for example, as by wrapping with insulating blankets) to reduce the possibility of cracking. To achieve a favorable microstructural response to subsequent stress relieving, the welded areas of martensitic stainless steel propellers are to be cooled as per above to the applicable temperature listed:

Grade CA-6NM and CB-6: 95°C (200°F) Grade CA-15: 205°C (400°F)

The welded areas of austenitic stainless steel propellers may be air cooled after welding.

3.7.5 Stress Relief

3.7.5(a) General (2006). After repair (welding, straightening and repitching) grades CA-6NM, CA-15 and CB-6 stainless steel propellers are to be stress relieved within the appropriate temperature range shown in 7-A-10/Tables 8 through 11. Grades CF-3 and CF-8 stainless steel propeller repairs do not require stress relieving treatments (see 7-A-10/Tables 7 and 11), except when special approval for straightening is required, as per 7-A-10/3.9.2(a).

3.7.5(b) Furnace Stress Relief. Where possible, furnace stress relief is to be carried out after repairs, especially for heavy sections such as the hub or the fillet areas. This may be done either by heating the entire propeller or by heating a complete section containing the areas to be stress relieved in a furnace or oven. Furnace stress relief of an entire propeller is to be effected by slow uniform heating to a temperature in the appropriate temperature range, and the soaking time at temperature is to be a minimum of 6 hours. Where only a section of the propeller is furnace stress relieved, the holding time is to be at least 20 minutes per 25.4 mm (1 in.) of section measured at the thickest portion of the repair area. Cooling of the propeller or propeller section is to be slow and uniform to 315°C (600°F) below which cooling in still air is satisfactory.

3.7.5(c) Local Stress Relief. In order to effect a suitable local stress relief, a band, as described below, is to be slowly heated to the stress relieving temperature so that a temperature gradient of 55°C per 300 mm (100°F per ft) is not exceeded. Heating is to be accomplished by means of soft gas torches or strip heaters or by means of moving oxyacetylene torches used with proper precaution to avoid local overheating. The soaking time at temperature is to be at least 20 minutes per 25.4 mm (1 in.) of thickness at the repair area. In the case of a weld repair, the weld thickness is to be used to determine the soaking time, but in no case is the soaking time to be less than one hour. Cooling of the propeller or propeller section is to be slow and uniform to 315°C (600°F) below which cooling in still air is satisfactory. For a local stress relief, the band is to measure approximately 300 mm (12 in.) on all sides of the repair and extend through the entire thickness of the blade. In addition, for local stress relief of a major repair, the band is to extend across the entire width of the blade.

3.7.5(d) Distortion Control. Adequate support to minimize distortion should be provided during any of the above mentioned stress relieving treatments.

3.7.6 Inspection After Welding

After welding repair operations and stress relief (if applicable) have been effected, the propeller is to be inspected in accordance with 7-A-10/3.5.3(b).

3.7.7 Marking

After welding repair operations and final inspection have been effected, the propeller is to be marked in accordance with 7-A-10/3.3.9(b).

3.7.8 Preparation for Storage

Propeller surfaces are to be protected after welding repair operations when required by 7-A-10/3.3.8.

3.9 Straightening

3.9.1 Major and Minor Straightening Repairs

Minor straightening repairs include the repair of edges on the outer $\frac{1}{3}$ of the propeller diameter and, in general, are to be limited to the repair of sections under 32 mm ($1\frac{1}{4}$ in.) thickness. Except for minor straightening repairs and straightening repairs which require special approval [see 7-A-10/3.9.2(a)], all repairs, including repairs to the critical area of high skew propellers, are considered major repairs.

3.9.2 Straightening Procedure

The straightening procedure given in 7-A-10/Table 10 is to be followed for making straightening repairs.

3.9.2(a) Grade CF-3 and CF-8 Stainless Steel. Procedures for straightening repairs to austenitic stainless steel (Grades CF-3, CF-8) propellers are subject to special approval when the inner radius of the blade deformation is less than ten times the section thickness. Other straightening repairs may be conducted by cold or hot straightening and by dynamic or pressure loading at the preference of the facility and in accordance with 7-A-10/Table 10. Hot straightening is not to be done over 455°C (850°F).

3.9.2(b) Grade CA-6NM and CA-15, CB-6 Stainless Steel (2009). Cold straightening of martensitic stainless steel (Grades CA-6NM, CA-15, CB-6) may be conducted only by pressure loading and only for minor straightening repairs. Hot straightening by means of dynamic or pressure loading may be used for all straightening repairs. Stress relief treatments after straightening are to be conducted as per 7-A-10/3.7.5 and 7-A-10/Table 10.

3.9.3 Hot Straightening

The portion of the propeller which is being hot straightened is to be kept within the required temperature range during the course of the repair by means of soft gas torches or strip heaters or by means of moving oxyacetylene torches used with proper precaution to avoid local overheating. A generous area surrounding the portion to be straightened is to be heated through its entire thickness to the required temperature. After straightening has been completed, the propeller may be slowly and uniformly cooled to ambient temperature. If the propeller is to be stress relieved, it is not necessary to first cool to ambient temperature.

3.9.4 Cold Straightening

For cold straightening, the portion of the propeller which is being straightened may receive a minimal amount or no prior heating, however, the minimum straightening temperature is to be 15°C (60°F).

3.9.5 Inspection After Straightening

After straightening repair operations and stress relief (if applicable) have been effected, the propeller is to be inspected in accordance with 7-A-10/3.5.3(b).

3.9.6 Marking

After straightening operations, see 7-A-10/3.3.9(b).

3.9.7 Preparation for Storage

Propeller surfaces are to be protected after straightening operations when required by 7-A-10/3.3.8.

3.11 Repitching

3.11.1 General

Repitching of a propeller is subject to special approval unless the change in pitch, measured at 0.7 radius, is less than 5% and the repitching is accomplished with uniform deformation and outside the blade 0.4 radius. No repitching of a propeller that has already undergone repitching is to be undertaken without special approval unless the cumulative absolute change in pitch is less than 5% and the above provisions are complied with.

3.11.2 Repitching by Pressure Loading

Repitching by means of slowly applied uniform loads is to be conducted within the temperature ranges indicated in 7-A-10/Table 10. Repitching by means of dynamic loading is not to be used. The portion of the propeller which is being repitched is to be kept within the required temperature range during the course of the repair by means of soft gas torches or strip heaters or by means of moving oxyacetylene torches used with proper precaution to avoid local overheating. A generous area surrounding the portion to be repitched is to be heated through its entire thickness to the required temperature. After the repitching has been completed the propeller may be slowly and uniformly cooled to ambient temperature. If the propeller is to be stress relieved, it is not necessary to first cool to ambient temperature.

3.11.3 Stress Relief

3.11.3(a) *Grade CF-3 and CF-8 Stainless Steel.* Stress relief treatment after repitching is not necessary for austenitic stainless steel (Grades CF-3, CF-8), as per 7-A-10/3.7.5(a) and 7-A-10/Table 10.

3.11.3(b) *Grade CA-6NM and CA-15 Stainless Steel (2009).* Stress relief treatment after repitching is to be conducted for martensitic stainless steel (Grades CA-6NM, CA-15, CB-6), as per 7-A-10/3.7.5 and 7-A-10/Tables 8-10.

3.11.4 Inspection After Repitching

After repitching operations and stress relief (if applicable) have been effected, the propeller is to be inspected in accordance with 7-A-10/3.5.3(b).

3.11.5 Marking

After repitching operations and final inspection have been effected, the propeller is to be marked in accordance with 7-A-10/3.3.9(b).

3.11.6 Preparation for Storage

Propeller surfaces are to be protected after repitching operations when required by 7-A-10/3.3.8.

TABLE 7
Parameters for Welding of Grades CF-3 and CF-8 Stainless Steel

<i>Filler Metal ⁽¹⁾</i>	<i>Shielded Metal Arc Welding</i>	<i>Gas Metal and Gas Tungsten Arc Welding</i>
AWS Specification	A5.4	A5.9
AWS Classification ⁽²⁾	E 308L E 347	ER 308L ER 347
<i>Temperature range in °C (°F)</i>		
Preheat & interpass range	15-260 (60-500)	15-260 (60-500)
Stress relief	None	None

Notes:

- 1 Equivalent specifications, such as for flux cored filler metals, may be used.
- 2 Type 308 filler metal may be used for repair of CF-8.

TABLE 8
Parameters for Welding of Grade CA-6NM Stainless Steel

<i>Filler Metal ⁽¹⁾</i>	<i>Shielded Metal Arc Welding</i>	<i>Gas Metal and Gas Tungsten Arc Welding</i>
AWS Specification	A5.4	A5.9
AWS Classification	E 410 NiMo	ER 410 NiMo
<i>Temperature range in °C (°F)</i>		
Preheat & interpass range	100-315 (210-600)	100-315 (210-600)
Stress relief	565-620 (1050-1150)	565-620 (1050-1150)

Note:

- 1 Equivalent specifications, such as for flux cored filler metals, may be used.

TABLE 9
Parameters for Welding of Grade CA-15 Stainless Steel

<i>Filler Metal ⁽¹⁾</i>	<i>Shielded Metal Arc Welding</i>	<i>Gas Metal and Gas Tungsten Arc Welding</i>
AWS Specification	A5.4	A5.9
AWS Classification	E 410	ER 410
<i>Temperature range in °C (°F)</i>		
Preheat & interpass range	205-315 (400-600)	205-315 (400-600)
Stress relief	660-790 (1220-1450)	660-790 (1220-1450)

Note:

- 1 Equivalent specifications, such as for flux cored filler metals, may be used.

TABLE 10
Parameters for Welding of Grade CB-6 Stainless Steel (2006)

<i>Filler Metal ⁽¹⁾</i>	<i>Shielded Metal Arc Welding</i>
Specification	DIN 8556
Grade	E 17 6 B 20+
<i>Temperature range in °C (°F)</i>	
Preheat & interpass range	150-200 (300-400)
Stress relief	580-630 (1100-1160)

Note:

- 1 Equivalent specifications, such as for gas metal arc, gas tungsten arc, and flux cored arc welding filler metals, may be used.

TABLE 11
Temperatures for Straightening and Repitching Stainless Steel Propellers (2006)

	<i>Grades CF-3 and CF-8</i>	<i>Grade CA-6NM and CB-6</i>	<i>Grade CA-15</i>
Temperatures for Minor Straightening in °C (°F)			
Dynamic loading	15-455 (60-850)	565-620 (1050-1150)	675-730 (1250-1350)
Pressure loading	15-455 (60-850)	15-620 (60-1150)	15-730 (60-1350)
Temperatures for Major Straightening in °C (°F)			
Dynamic loading	15-455 (60-850)	565-620 (1050-1150)	675-730 (1250-1350)
Pressure loading	15-455 (60-850)	565-620 (1050-1150)	675-730 (1250-1350)
Temperatures for Repitching, in °C (°F)			
Pressure loading	15-455 (60-850)	565-620 (1050-1150)	675-730 (1250-1350)
Temperatures for Stress Relief After Straightening or Repitching, in °C (°F)	None	565-620 (1050-1150)	660-790 (1220-1450)

FIGURE 6
Typical Shallow Groove Preparation for Welding Repair

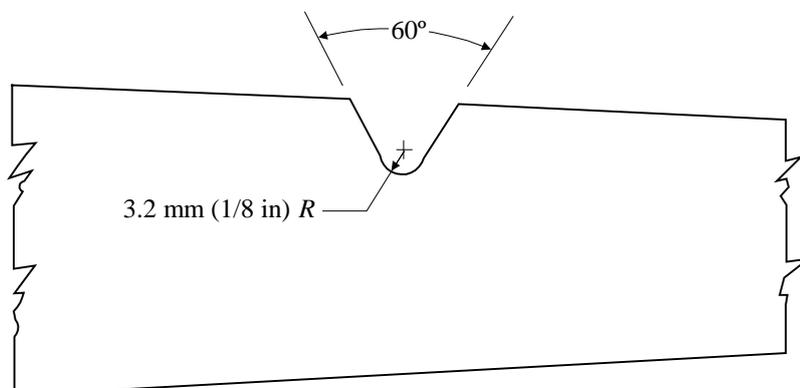

FIGURE 7
Typical Deep Groove Preparation for Welding Repair

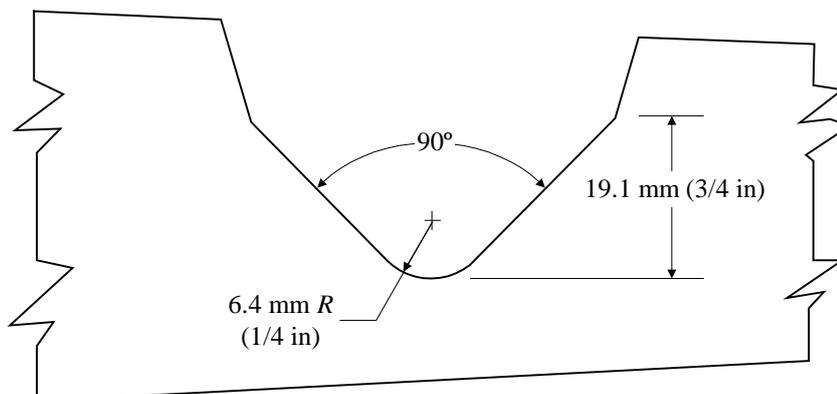

FIGURE 8
Typical Blade Tip Replacement Preparation for Welding Repair

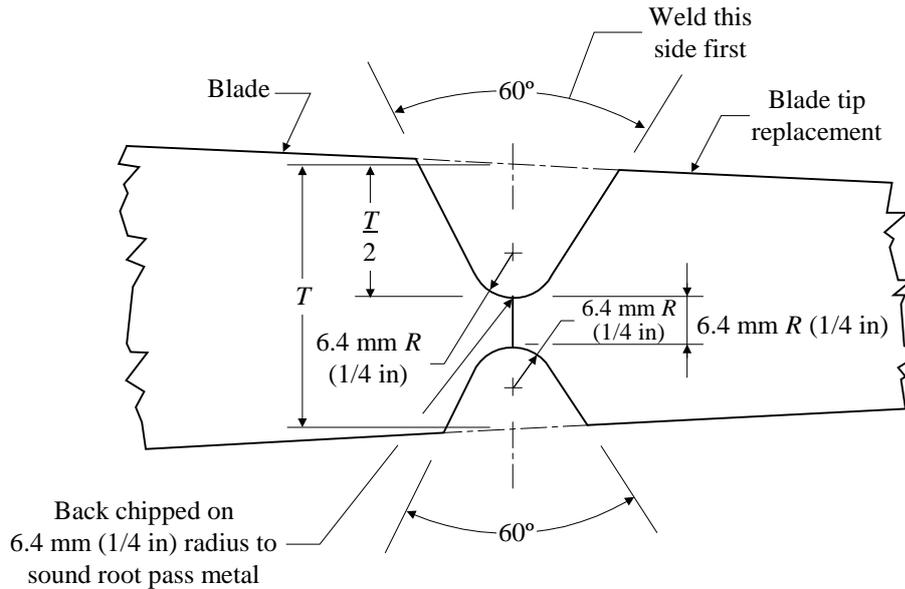
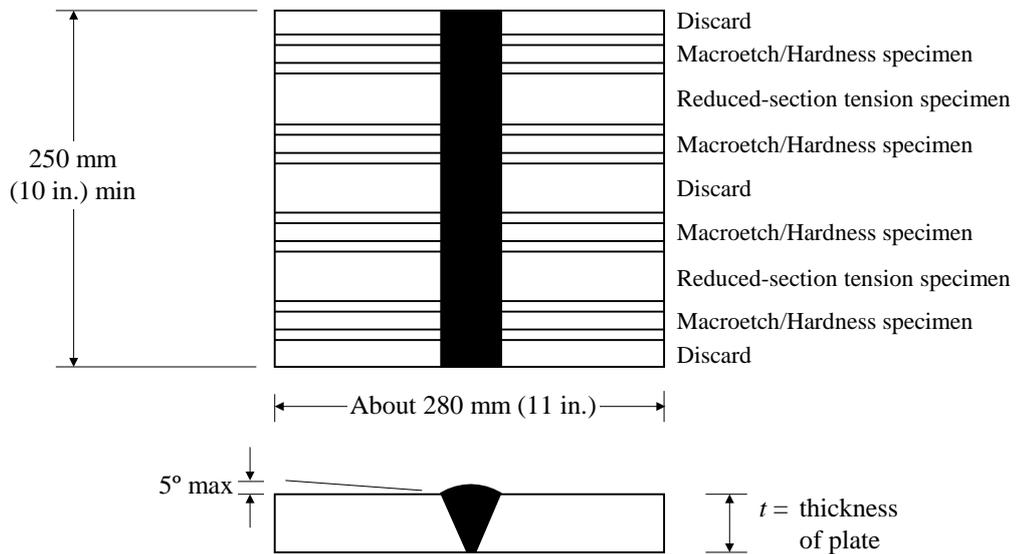

FIGURE 9
Welding Qualification Test Plate Location of Test Specimens (2009)



Notes:

- 1 $t = 30 \text{ mm } (1\frac{1}{4} \text{ in.})$ minimum.

Acceptance Criteria for Procedure Qualification Tests

- 1 For reduced-section tension test, see 7-A-10/Figure 10.
- 2 (2009) For macroetch test, the specimen is to be free of cracks; and, no welding discontinuity over 1.6 mm ($\frac{1}{16}$ in.) is permitted. One of the macro-sections shall be used for hardness testing. Indentations shall traverse 2 mm below the surface. At least three individual indentations are to be made in the weld metal, the HAZ (both sides), and in the base material (both sides). The values are to be reported for information.

FIGURE 10
Reduced-section Tension Specimen (2009)

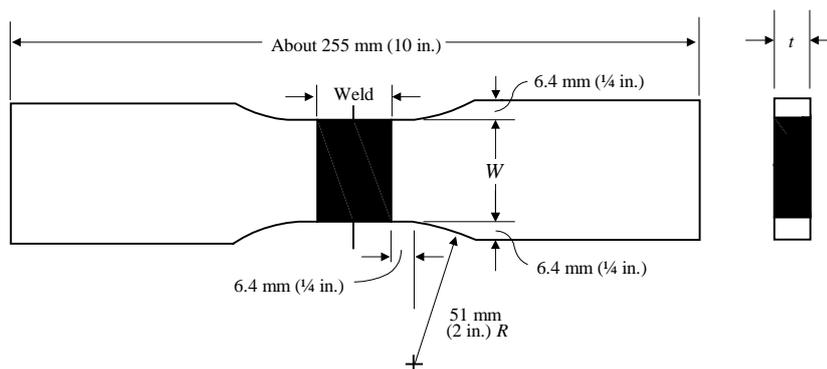

Notes:

- 1 Both faces of weld are to be machined flush with plate.
- 2 (2009) $t = 30 \text{ mm (1 1/4 in.)}$; $W = 25.4 \text{ mm (1 in.)}$.
- 3 When the capacity of the available testing machine does not permit the full thickness specimen, two or more thinner than full thickness specimens may be prepared by cutting the full thickness specimen into sections, each of which is to meet the requirements.

Requirement: Weld test

- 1 Minimum tensile strength for cast bronze, in N/mm^2 (kg/mm^2 , psi)

	Arc Process	Oxyfuel Gas Process
Type 2 - Mn Bronze	380 (39, 55,000)	275 (28, 40,000)
Type 3 - NiMn Bronze	410 (42, 60,000)	315 (32, 45,000)
Type 4 - NiAl Bronze	500 (51, 72,000)	-
Type 5 - MnNiAl Bronze	550 (56, 80,000)	-

- 2 Minimum tensile strength for stainless steel, in N/mm^2 (kg/mm^2 , psi)

	Arc Process
Grade CF-3	480 (49, 70,000)
Grade CF-8	480 (49, 70,000)
Grade CA-6NM	755 (77, 110,000)
Grade CA-15	620 (63, 90,000)

PART

7

APPENDIX

SECTION 11 Repair and Cladding of Shafts (2013)

Note: This Appendix contains ABS requirements for the repair, welding and cladding of tail shafts and stern tube shafts. The welding and cladding procedures are also applicable to line shafts, rudder stocks, and pintles. This Appendix supersedes 2011 edition of *ABS Guide for Repair and Cladding of Shafts (7-A-11)*.

1 Scope

1.1 General

This Appendix describes procedures for the repair of stern tube shafts and tailshafts. It also covers procedures for cladding of shafts and repair of clad areas. Procedures and techniques differing from those outlined herein are subject to special consideration provided that all the supporting documents are submitted for ABS review.

Note that procedures described in the following sections are not applicable to engine crankshafts.

1.3 Materials

The procedures are applicable to shafts made from carbon steel forgings such as ABS Grades 2, 3 and 4 or their equivalents, and alloy steel forgings such as those covered by specification MIL-S-23284, classes 3 and 4, or other weldable grades of military or commercial specifications. The procedures are also applicable to fully killed carbon steel rolled bar material when permitted for shafting, and for material such as carbon steel plates and castings when specially approved for flanges. Repair of stainless steel shafts are subject to special consideration.

1.5 Arrangements, Fees, and Renewal of Approvals for Welding and Cladding

Arrangements for witnessing of tests, examinations, payment of required fees and other details are to be made with the local ABS Office. Facility approvals for welding and cladding are subject to renewal after five years. Re-approval will be based on submission of satisfactory evidence of personnel qualifications, procedures and experience with the approved procedures. Facilities wishing to renew their approvals are required to advise the local ABS Office prior to the expiration of their approvals.

3 Repair without Welding

A defect may be removed by turning, grinding or filing if the resulting excavation is no deeper than 3.2 mm (1/8 in.) for shafts up to 255 mm (10 in.) diameter, or no deeper than 6.4 mm (1/4 in.) for shafts over 255 mm (10 in.) diameter. All excavated areas are to have a smooth finish with a radius of no less than one fourth of the shaft diameter. Magnetic particle examination of the area is to be made to verify complete removal of defects.

5 Repair by Welding – Facility Approval

5.1 General

Weld repairs on stern tube shafts or tail shafts are to be performed in an approved facility.

5.3 Application for Approval (2012)

Application for approval as a facility approved for welded repairs on stern tube shafts and tail shafts is to be made to the ABS Materials Department. In general, the following will be required:

- Inspection of the facility by an ABS Surveyor
- Submission of operator qualifications
- Submission of welding procedures (see 7-A-11/5.5)
- Submission of ultrasonic examination procedure (see 7-A-11/5.7)
- Submission of testing results (see 7-A-11/5.9)

5.5 Welding Procedure

5.5.1 General

A welding procedure test will be required for each grade of steel for which approval is requested. Prior to conducting the procedure test, the welding procedure is to be approved by the Materials Department.

5.5.2 Welding Procedure Approval

A written description of the welding procedure is to be submitted to the Materials Department for review and approval. Description of the procedure is to include the following (see also 7-A-11/9):

- Base metal specification (and composition, if known)
- Filler metals including brand, type and size
- Joint design
- Welding process
- Preheat temperature and method
- Interpass temperature
- Sequence and method of depositing weld beads
- Method of inspecting weld beads
- Postweld heat treatment and method
- Method of final inspection
- Ultrasonic examination procedure (see 7-A-11/5.7)

5.5.3 Welding Procedure Test

The welding procedure test is to be conducted in the presence of a Surveyor.

5.7 Ultrasonic Examination Procedure

The intent of ultrasonic examination in connection with welded shafts is twofold: To determine that the weld is free from defects; to determine that the area beneath the aft liner (where fitted) is free from cracks. Facilities seeking approval for weld repairs are to submit an ultrasonic examination procedure for approval as follows: The proposed ultrasonic examination procedure is to be submitted in writing to the Materials Department. After satisfactory review, the procedure is to be demonstrated to the Surveyor's satisfaction on a sample tail shaft or equivalent substitute. This sample shall contain at least six simulated defects located forward of the large end of the taper, the farthest imperfection being 300 mm (12 in.) from the large end of the taper (7-A-11/Figure 4). Detection of the defects is to be demonstrated by shear wave scanning on the tapered portion of the shaft. The recommended frequency is 2.25 MHz.

5.9 Mechanical Tests

Upon the completion of the test weld and after the required stress relief heat treatment, a test coupon 292 mm \pm 6.4 mm (11 $\frac{1}{2}$ \pm $\frac{1}{4}$ in.) long with the weld in the center is to be prepared. Test specimens in 7-A-11/Figure 3 are to be machined, and tested in the presence of a Surveyor. Test results are to be submitted to the Materials Department.

7 Preparation and Examination of Shafts Prior to Welding

The preparation and examination of tail shafts and stern tube shafts is to be performed under the surveillance of a Surveyor. Defects are to be excavated to sound metal. When deep cracks extend partially around the shaft circumference, it is recommended that grooves be cut completely around the shaft to permit balanced welding. Alternatively, defects may be removed by partial grooving, and warpage due to welding controlled by peening or other means. To be considered for repair by welding, defect depths are not to exceed 20% of the shaft diameter. Repairs to hollow shafts that involve the full wall thickness are subject to special consideration. Magnetic particle method is to be used to determine that all defects have been completely removed. All tail shafts with fitted aft liners to be repaired by welding are to be examined under the liner using the approved ultrasonic procedure in 7-A-11/5.7. In general, the examination is to extend from the aft end of the liner to 300 mm (12 in.) forward. If this examination shows indications of a defect under the liner, the liner is to be removed to the extent necessary to effect examination and repair. Precautions are to be taken to avoid marring the shaft surface during liner removal.

9 Production Welding

9.1 Submission of Details

Details, including a sketch showing the extent of each proposed repair, are to be summarized in brief form and submitted to the Materials Department. The details are to include name of vessel, original shaft markings, shaft type, size, and material, and reference made to the approved procedure.

9.3 Welding Processes

Weld repairs may be made with an approved manual or automatic welding process. The storage and use of welding consumables is to be in accordance with manufacturer's recommendations. In all cases, the properties of the weld deposit, after heat treatment, are to be comparable to base metal. However, in the case of alloy steel shafts, carbon or alloy steel weld deposits lower in strength than the base metal may be used for depositing the first bead of weld metal in the groove in order to minimize the effects of dilution and rapid quench on the strength and ductility of the weld metal. When possible, the welding is to be done in the flat or downhand position. In welding shafting with circumferential grooves, the welding may be automated or semi-automated, utilizing a positioner or rotating device to position the shaft, and employing either a stationary welding head for automatic welding or a hand held electrode holder for semi-automatic welding. Welding speed is to be regulated with the shaft rotation to prevent slag interference or incomplete fusion during welding.

9.3.1 Shielded Metal Arc and Gas Metal Arc Welding

Low hydrogen electrodes or processes are to be used. Gas metal arc welding is to be performed under conditions that result in a stable arc.

9.3.2 Submerged Arc Welding

When heat input rates in excess of 2165 Joules/mm (55,000 Joules/in) are used, information submitted for procedure qualification is to show the use of a tempering bead technique, and that the heat affected zone was not adversely affected by the heat input.

9.3.3 Other Welding Processes

The techniques used with welding processes other than those indicated in 7-A-11/9.3.1 and 7-A-11/9.3.2 above will be specially considered.

9.5 Examination During Welding

The first weld layer is to be examined by magnetic particle method. Additionally, with submerged arc welding, the last two layers are to be examined by magnetic particle method.

9.7 Preheat and Interpass Temperature

A minimum preheat and interpass temperature of 135°C (275°F) is to be used for ordinary strength carbon steels. For the higher strength carbon steels and alloy steels, the preheat and interpass temperatures are to fall in the range of 135°C (275°F) to 260°C (500°F), the values specified being suitable for the particular material and welding process involved.

9.9 Distortion Control

A welding sequence is to be used that minimizes or eliminates distortion. It may include appropriate application of peening or heating, or both. However, peening is not allowed on the final weld layer. Shafts are to be fitted with dial indicators to permit continuous checking of shaft alignment during welding operations. Residual distortion present prior to postweld heat treatment is to be corrected by adjusting supports or by other means to permit straightening the shaft during the postweld heat treatment.

9.11 Postweld Heat Treatment

Prior to heat treatment, the shafts are to be covered with a suitable heat resisting scale preventative. The shafts are to be postweld heat treated at $635 \pm 14^\circ\text{C}$ ($1175 \pm 25^\circ\text{F}$) for carbon steels and $663 \pm 14^\circ\text{C}$ ($1225 \pm 25^\circ\text{F}$) for alloy steels, with a minimum holding time of two (2) hours per 25.4 mm (1 in.) or fraction thereof of weld thickness, except that the maximum holding time need not exceed eight (8) hours for any repair, unless specially required otherwise. In the case of alloy steels, use of stress relief temperatures other than $663 \pm 14^\circ\text{C}$ ($1225 \pm 25^\circ\text{F}$) may be specially considered. The maximum rate of raising and lowering the temperatures of the shafts is not to exceed 52°C (99°F) per hour. Shafts may be cooled in still air after reaching 232°C (450°F).

9.11.1 Intermediate Stress Relief

In cases where the grooves to be welded are over 100 mm (4 in.) deep, an intermediate stress relief heat treatment is to be done after one half of the depth of groove, measured in depth, has been welded.

9.11.2 Stress Relief Methods

Furnace heating is an acceptable method of stress relief and is the required method for shafts in which the repaired areas are not localized. For shafts with circumferential repairs, where the areas affected by the welding are relatively narrow, stress relieving by local heating with resistance or induction type portable units may be considered acceptable, provided the width of the heated area at each side of the weld is at least twice the weld thickness.

11 Examination after Welding (2008)

After post weld heat treatment, machining and cleaning of the shaft, the welds and adjacent areas are to be checked for cracks or other imperfections by magnetic particle inspection and an approved ultrasonic examination method. During the ultrasonic examination, particular attention is to be directed toward inspecting for discontinuities under the aft liner, if fitted, in the deposited weld metal, and other areas not accessible to ultrasonic inspection because of interference from the defective area that had required repair. The shaft is to also be checked for alignment after final heat treatment and be within the specified straightness tolerances.

13 Final Finishing

During final finishing of the shaft, it may be necessary to take a light cut on the taper. In such cases, the propeller clearance is to be verified using indicators such as Prussian Blue. When machining the forward end of the taper, small fillet radii are to be cut into the end of the liner to avoid a sharp step between the shaft and the end of the liner, as shown in 7-A-11/Figure 5. Consideration is to be given at this time to provide relief grooves in both ends of the liner and at the bottom of the propeller hub counter bore, as shown in 7-A-11/Figure 6.

15 Marking of Shafts Repaired by Welding

Shafts that are reconditioned by means of welding, in accordance with 7-A-11/9 or an approved procedure, are to be stamped **Welded-S.R.**, along with the attending Surveyor's identification marks, so that it will be clear to the installation Surveyor that such shafts have been welded and stress relieved. Where the original shaft identification marks have been obliterated, new marks are to be added in a low stress area.

17 Cladding of Shafts by Welding

17.1 General

Cladding of stern tube shafts and tail shafts by welding is to be performed in an approved facility.

17.3 Facility Approval (2012)

Application for approval as a facility for cladding of stern tube shafts and tail shafts is to be submitted to the ABS Materials Department with the following required documents:

- Operator qualification data (see 7-A-11/17.7)
- Welding procedure (see 7-A-11/17.9)
- Welding procedure test results (see 7-A-11/17.9.2)

17.5 Materials

The procedures contained herein for cladding of shafts apply to the deposition of austenitic stainless steel or monel on tail shafts with approved arc welding procedures. Cladding employing other overlay materials or other welding processes will be specially considered. Carbon steel cladding may be qualified in accordance with this section, provided that the finished weld thickness does not exceed 3.2 mm ($1/8$ in.) for shafts up to 255 mm (10 in.) in diameter or 6.4 mm ($1/4$ in.) for shafts over 255 mm (10 in.), and the finished weld is post weld heat-treated in accordance with 7-A-11/9.11. In such cases, the minimum clad thickness of 7-A-11/17.13 is not applicable. Unless specially approved otherwise, carbon steel cladding in excess of the thickness noted above is to be in accordance with 7-A-11/5.

17.7 Welder or Welder Operator Qualifications

The Surveyor is to be satisfied that the welders are proficient in the type of work that they are called on to perform, through due consideration of employment, training, apprenticeship, plant testing, inspection, etc. When qualification testing is considered necessary to verify proficiency, the tests indicated in 7-A-11/Figure 8 are to be conducted.

17.9 Weld Procedure Approval

Overlay procedures used are to be qualified in accordance with 7-A-11/17. A new procedure qualification is to be obtained for any significant change in base metal, overlay material or weld procedure variable.

17.9.1 Procedure Tests (2012)

Procedure tests are to be conducted in the presence of and to the satisfaction of the Surveyor on a sample of material and diameter representative of production. The following details of the procedure and the test results are to be submitted to the Materials Department for approval:

- Base metal specification, chemical composition and mechanical properties
- Welding process
- Preheat and interpass temperature
- Postweld heat treatment (if none - so state)
- Filler metal specification, manufacturer and chemical composition
- Method of inspection

17.9.2 Required Test Data

The following procedure test results based on specimens in accordance with 7-A-11/Figure 7 are to be submitted:

- Four side bend tests [see 2-4-3/Figure 6 of the *ABS Rules for Materials and Welding (Part 2)*] (no cracking permitted in the cladding or interface)
- Four macro-specimens across the weld located 90 degrees apart (free from cracks at 10X magnification)
- Hardness surveys conducted across the welds on the macro-specimen (Microhardness or Rockwell)

17.11 Cladding/Base Metal Dilution

Appropriate precautions are to be taken to minimize deleterious effects associated with the dilution of the clad layer by the base metal during welding. In the case of austenitic stainless steel cladding on carbon or alloy steel shafting, the use of a stainless filler metal such as Type 309 or equivalent is required for the initial weld layer. The appropriate type of stainless steel is then to be used for subsequent layers.

17.12 Cladding on Taper (2007)

If cladding is carried out in way of any part of the taper, cladding is to be extended over the entire surface of the taper.

17.13 Finish Machining

The entire extent of the cladding, including that extending beyond the bearings, is to be machined to a maximum surface roughness of 3.2 micrometers (125 microinches) RMS (root mean-square), or equivalent. The ends of clad areas are to be tapered at an angle of approximately 15°, and the clad/shaft junctions are to be free from notches. The minimum thickness of cladding after machining is to be 4.8 mm (³/₁₆ in.), except at tapered ends.

17.15 Final Examination

The entire finish machined area of the cladding is to be examined by dye penetrant or other suitable method.

17.17 Marking of Shafts Clad by Welding

After the completion of all welding and inspection, the clad shaft is to be identified by stamping the cladding type in the flange recess, along with other applicable markings e.g., **309-316 SS clad**.

19 Repair of Clad Shafts

19.1 General

Repair of clad shafts by welding may only be performed by facilities and welders qualified under the provisions of 7-A-11/17. Before repairing a clad shaft, the cladding material is to be identified either by such means as reference to an existing stamping, the original report describing the cladding, or spot tests as described in 7-A-11/19.9. Any shaft which is not stamped to identify clad material present is to be appropriately marked in the flange recess after the clad material has been identified, e.g., **309-316 SS clad**.

19.3 Depth of Defect

Defects are to be ground out and the removal verified by a suitable technique such as dye penetrant inspection. A determination is to be made as to whether the repair is restricted to the cladding or extends into the base metal. The tests described in 7-A-11/19.9 may be used to determine the extent of repair.

19.5 Repair of Defects That Do Not Penetrate Into Base Metal

A defect in the cladding that does not penetrate into the base metal of the shaft (see 7-A-11/19.3) may be repaired by either grinding the defect to a large radius so as to reduce the stress concentration or by chipping and grinding the cladding to sound metal and then filling the resulting depression with the same type filler metals used for the original cladding. If the resulting depression extends through the clad layer to the underlying base metal, this paragraph does not apply and reference is to be made to 7-A-11/19.7.

19.7 Repair of Defects That Penetrate Into Base Metal

Clad shafts having defects that penetrate into the base metal of the shaft may be permanently repaired if the penetration into the base metal is less than 3.2 mm ($1/8$ in.) for shafts up to 255 mm (10 in.) in diameter or less than 6.4 mm ($1/4$ in.) for shafts exceeding 255 mm (10 in.) in diameter. Where the penetration into the base metal is greater than those indicated above, repairs will be considered under the provisions of 7-A-11/5 through 7-A-11/15. For austenitic stainless steel clad shafts, Type 309 or equivalent weld deposit is to be used for the initial layer which is deposited on the carbon or alloy steel shaft to minimize dilution effects. The appropriate type of stainless steel is to then be used for subsequent layers. For monel clad shafts, Type Ni Cu-1 or 2 electrodes are to be used.

19.9 Cladding Identification Procedures

The following chemical spot tests may be used to identify cladding material referred to in 7-A-11/19.9.1 and 7-A-11/19.9.2:

19.9.1 Nitric Acid Test

When a 50% nitric acid solution is placed on austenitic stainless steels, there is no chemical reaction. When the acid is placed in contact with carbon steel, the acid will turn brown, and when it is placed in contact with monel, the acid will turn a greenish blue.

19.9.2 Copper Sulfate Test

When a 5% to 10% solution of copper sulfate is put into an excavation that has been cleansed of grease and foreign matter, the carbon steel, when present, will become coated with metallic copper in a short time, while stainless steel or monel will not be affected.

21 Metal Spraying on Shafts and Liners

When shafts or shaft liners are to be metal sprayed, information is to be submitted to the ABS Materials Department for review and approval prior to spraying. Such information is to include: details of the process, materials, procedure, service experience and specifics of intended location to be sprayed.

FIGURE 1
Joint Design for Weld Repair in Solid Shafting for Procedure Approval

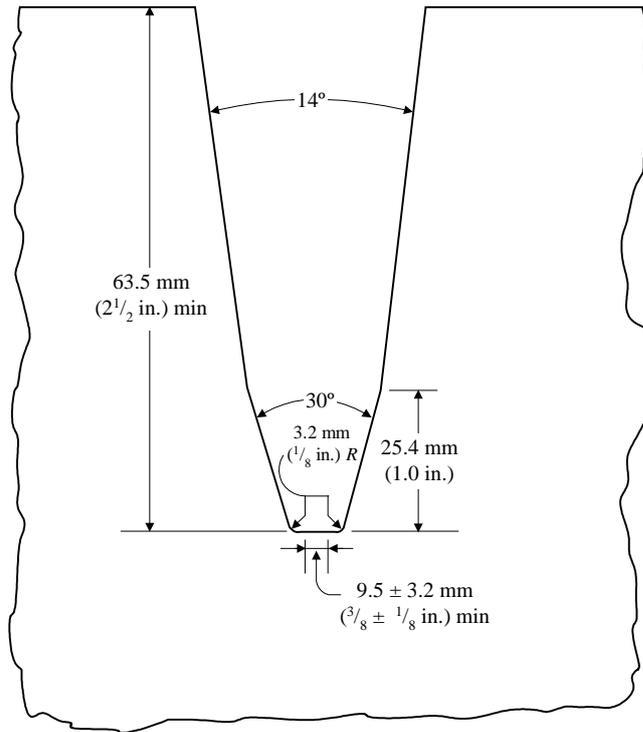

FIGURE 2
Joint Design for Welding Hollow Steel Shafting for Procedure Approval

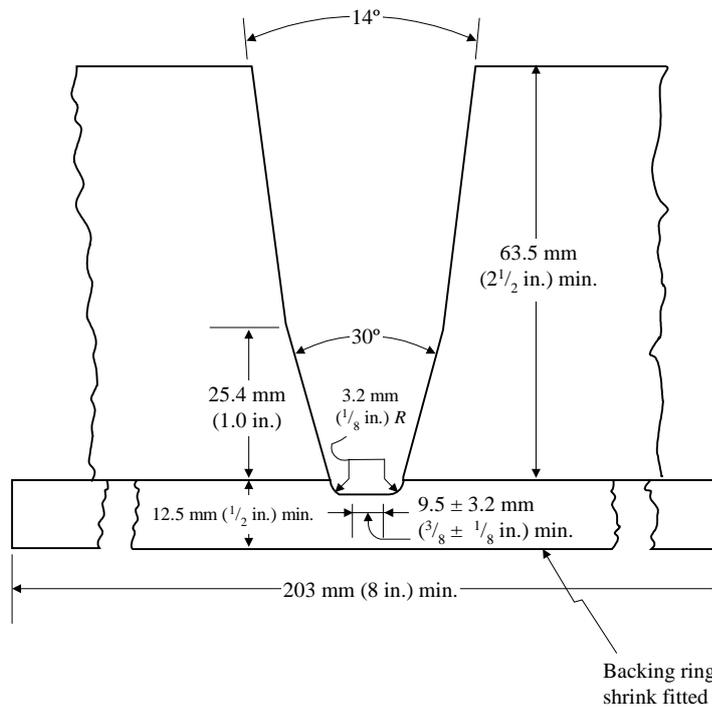

FIGURE 3A Test Pieces and Requirements for Procedure Approval

Composite base and weld metal samples selected from different regions for chemical analysis.

- 1 Two transverse tension tests, see 2-4-3/Figure 3 of the *ABS Rules for Materials and Welding (Part 2)*
- 2 Three metallographic and hardness specimens
- 3 Three side bend tests, see 2-4-3/Figure 6 of the *ABS Rules for Materials and Welding (Part 2)*
- 4 Two all base metal 12.5 ± 0.25 mm (0.500 ± 0.010 in.) diameter tension specimens (circumferential direction)
- 5 One all base metal 12.5 ± 0.25 mm (0.500 ± 0.010 in.) diameter tension specimen (longitudinal direction)
- 6 Two all weld metal 12.5 ± 0.25 mm (0.500 ± 0.010 in.) diameter tension specimens (circumferential direction)
Tensile and yield strength are to be compatible with the base metal.
- 7 Spare

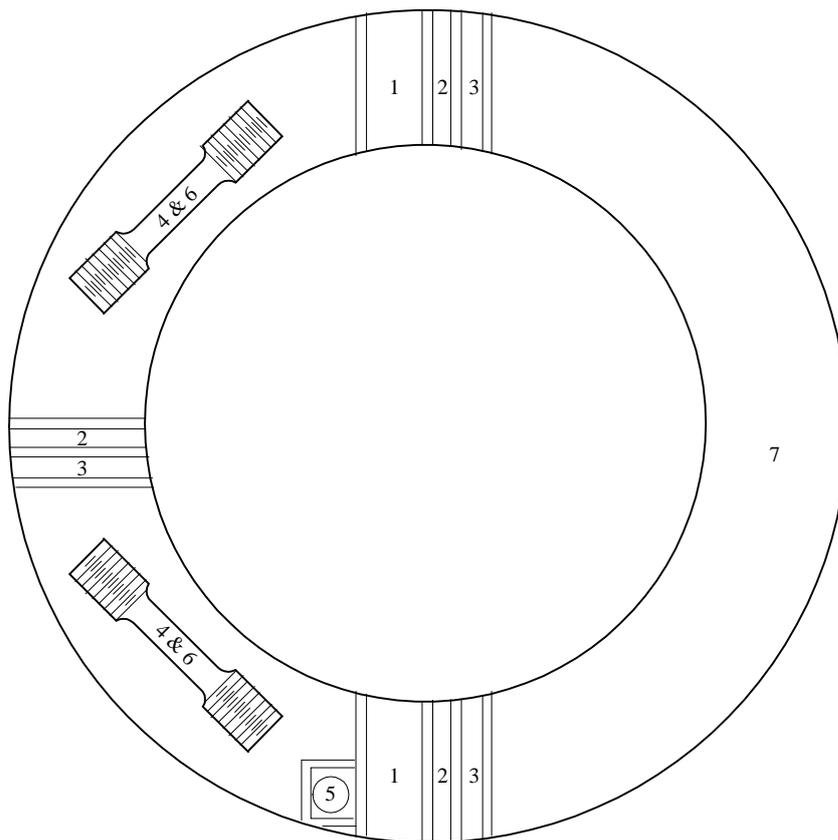

FIGURE 3B
Location for Hardness Measurements Across the Weldment (2017)

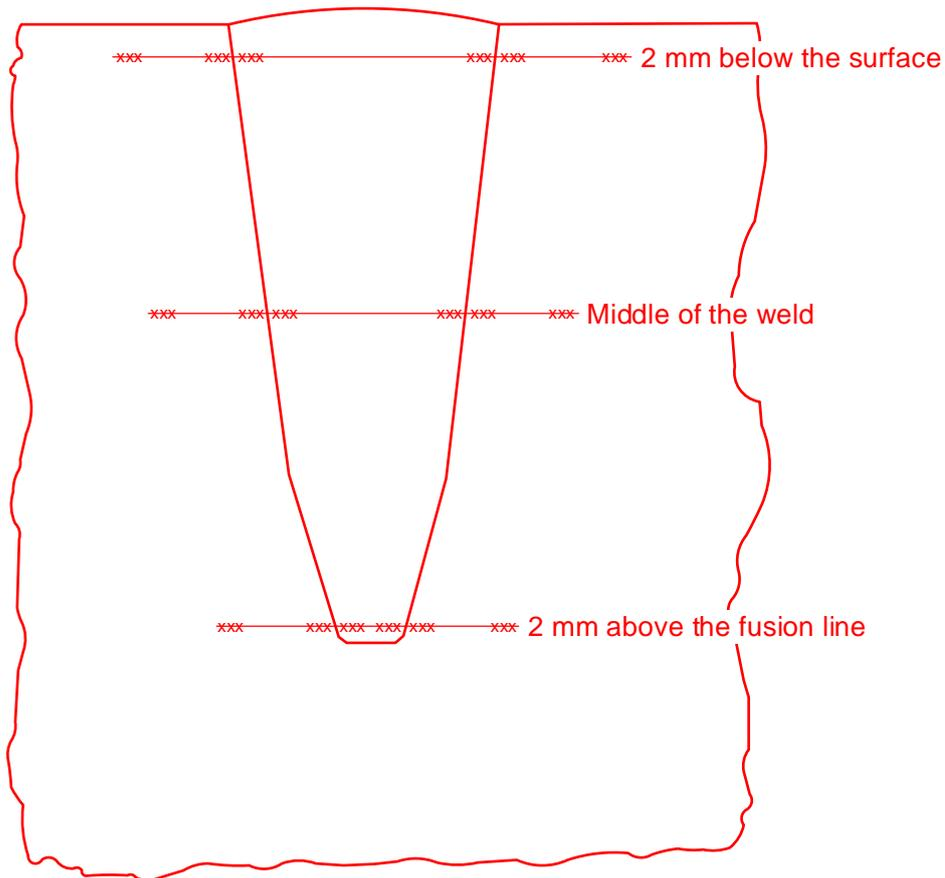
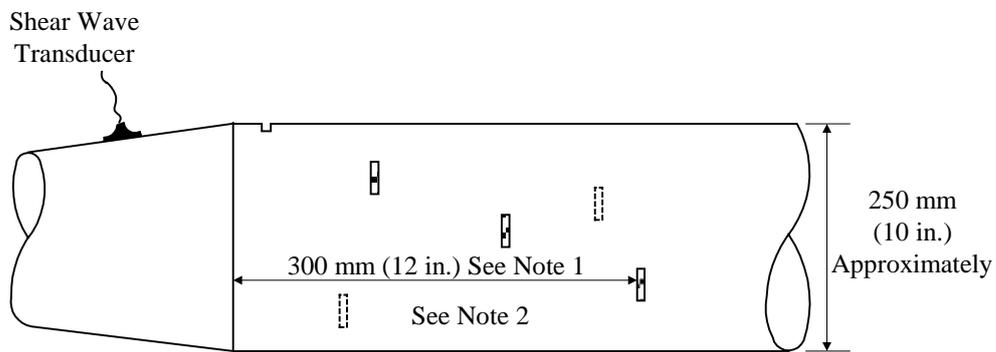

FIGURE 4
Ultrasonic Test Shaft



Notes:

- 1 One notch 75 mm (3 in.) by 1.6 mm (0.0625 in.) by 1.6 mm (0.0625 in.).
- 2 Five or more additional notches ranging in depth from 0.65 mm (0.025 in.) to 3.2 mm (0.125 in.).

FIGURE 5
Recommended Contour for Shafting at Liner

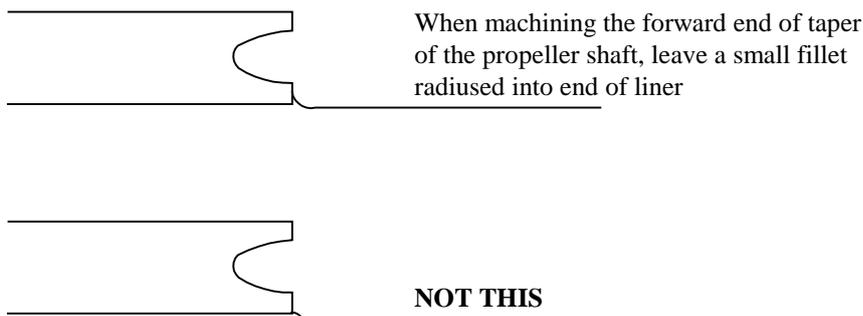

FIGURE 6
Suggested Hoop Stress Relief for Propeller Hub and Shaft Liner

It is important that the stress relief grooves be at least 12.5 mm ($1/2$ in.) deep and that the thickness of the lip at the edge be held at 1.6 mm ($1/16$ in.). The side of the stress relief groove adjacent to the shaft is to have an easy slope, as shown, to provide effective relief over a distance of at least 6.4 mm ($1/4$ in.) from the edge of the fit.

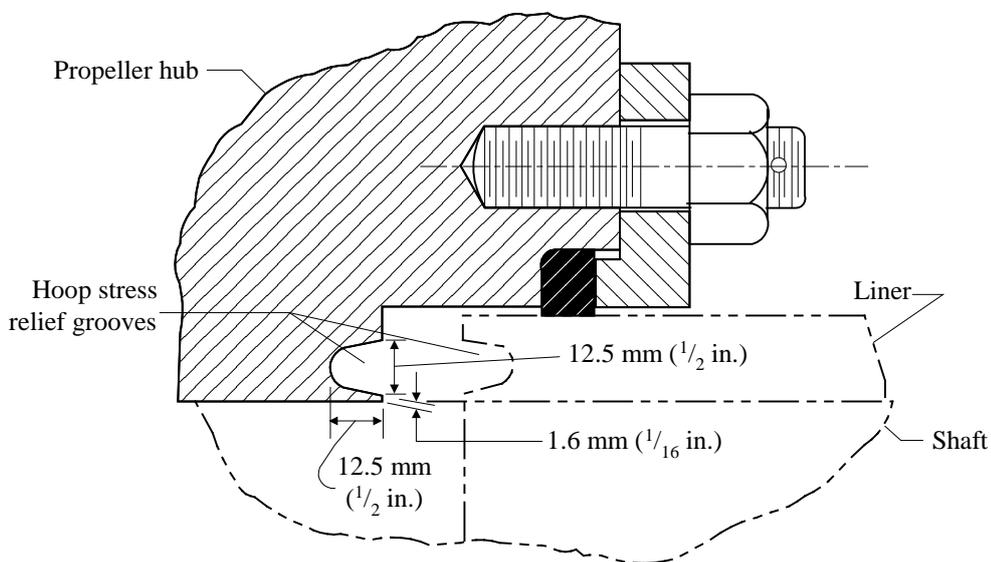

FIGURE 7
Weld Procedure Test Specimens for Shafts with
Built-up Welded Stainless Steel or Carbon Steel Cladding (2009)

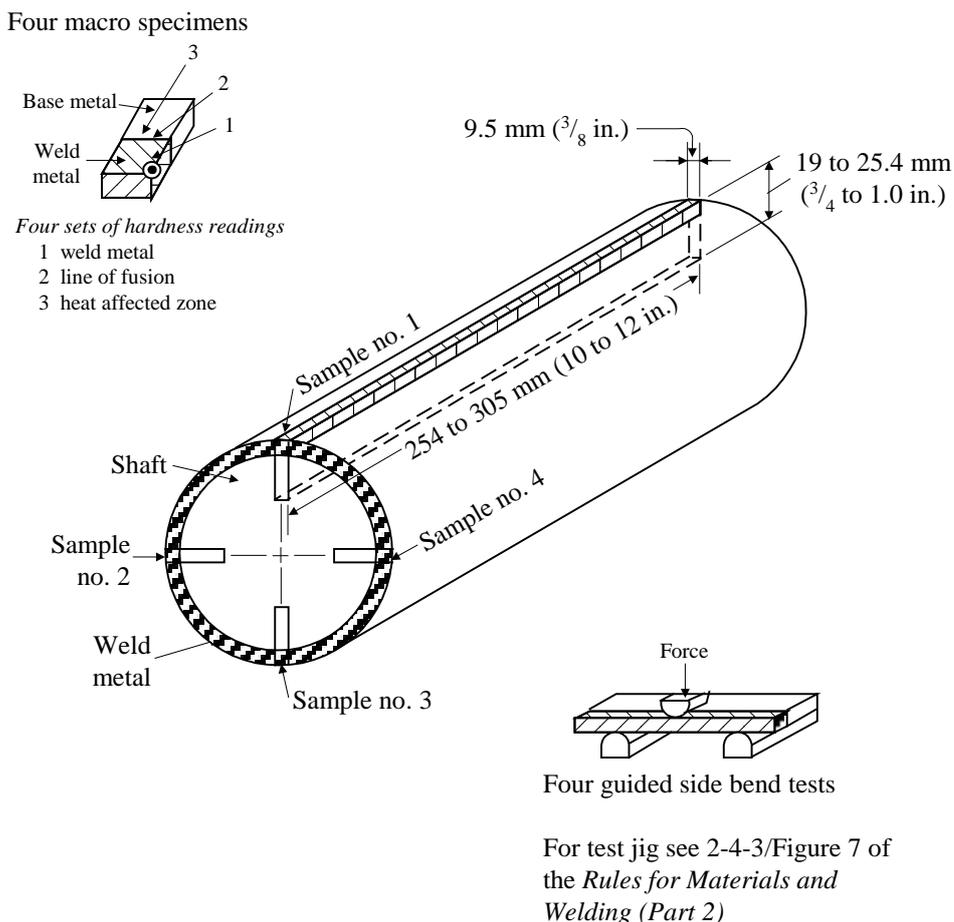
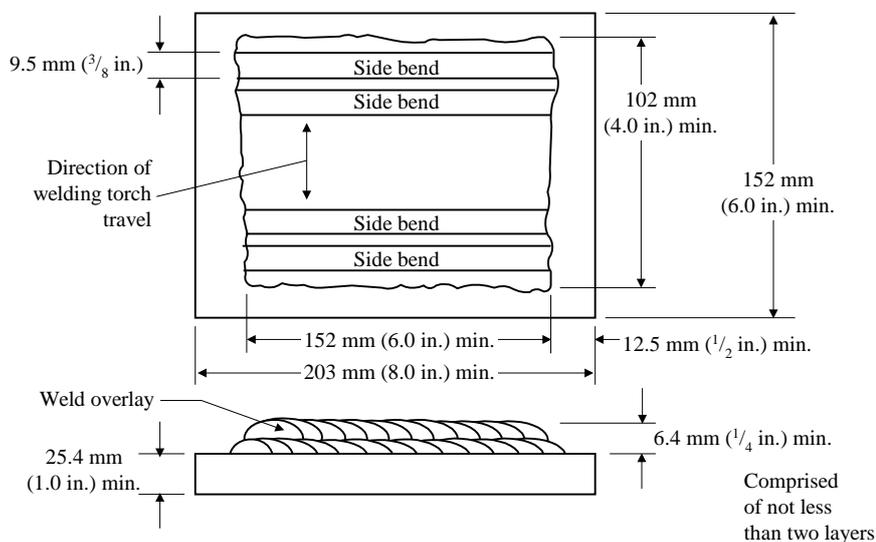

FIGURE 8
Welder Qualification Test Cladding (2009)



Annex Suggested Form for Ultrasonic Inspection of Shafts

**Suggested Form for Ultrasonic Inspection of Shafts
(Administrative Data)**

1. Report Number:

2. Date

3. Shipyard

4. Propeller Shaft History
Source (Manufacturer and/or Vessel)
Condition (Describe or sketch any known defects,
calibration notches or previous repairs)
Service history (Indicate to extent known)

5. Subject (Indicate if approval demonstration, shaft
repair, periodic inspection, etc.)

6. Attendees (Shipyard, ABS, Other)

7. NDT personnel Conducting
inspection (Name, Title, Basis of Qualifications
(such as SNT-TC-1A, courses))

8. Disposition of shaft (Indicate scrap, put in
service, store, etc. on the basis of items 12 through 16)

9. This report prepared by
(Name and Title of Shipyard personnel)
Date

10. This report reviewed by
(Name and Title of Shipyard personnel)
Date

11. This report reviewed by (ABS Surveyor)
Date

**Suggested form for Ultrasonic Inspection of Shafts
 (Results of Tests)**

12. (Indicate on location sketches, areas covered by inspections, positions of transducers, locate and number the areas showing significant visual, magnetic particle, dye penetrant and/or ultrasonic test indications, distance of keyway end to taper end)

13. Results of Ultrasonic Inspection (Conducted with liner in place or removed. Report all significant indications including those of known origin. If none so state)

Compression		Shear
End	Shoulder	On Taper

Transducer Background Level
 (% Screen height)

Indication No. (As shown on location sketches attached)
% Screen Height
Length
Dept (Estimated)
Interpretation (Crack, keyway, etc.)

14. Result of visual and other than UT inspection

Indication No. (As shown on location sketches attached)	
Length	
Depth	

15. Discrepancies between inspections under 13 and 14 above
 (Indicate presence of indication by + and absence by - in Table below)

Indication No.	Shoulder	End	Taper	Visual and other than UT	Remarks*

16. Results of re-inspection of shaft after any required repair
 (Repair to be authorized by Materials Department)

* Report any unusual conditions which interfered with inspection, such as excessive attenuation, interfering notches, etc.

Number all significant indications 1, 2, 3, etc., prefaced by appropriate letter. When the same defect produces indication, show it as the same number in the respective sketch: S2, V2, etc.

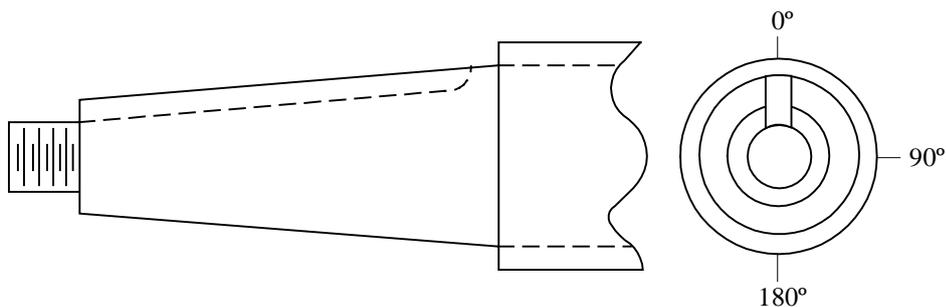

COMPRESSION (LONGITUDINAL) WAVE – END
 (Preface indication Nos. with “E”)

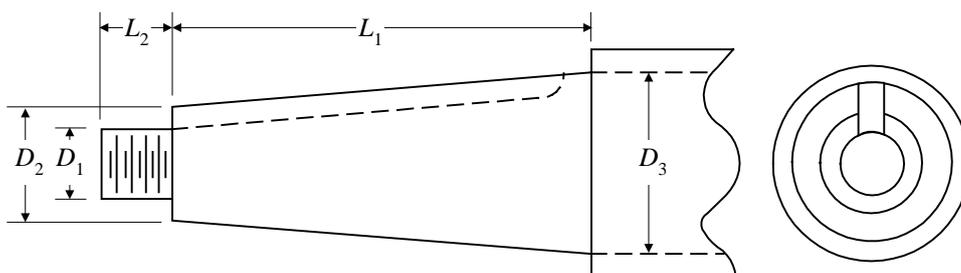

COMPRESSION (LONGITUDINAL) WAVE – SHOULDER
 (Preface indication Nos. with “S”)

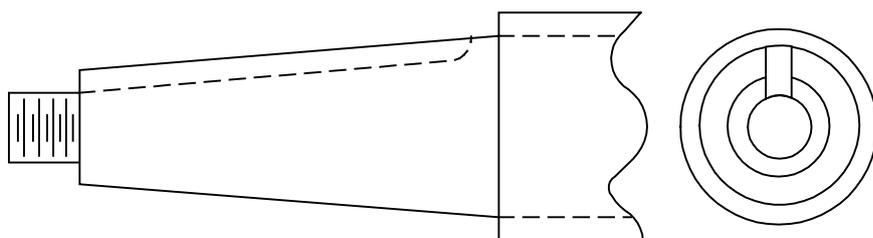

SHEAR WAVE – TAPER
 (Preface indication Nos. with “T”)

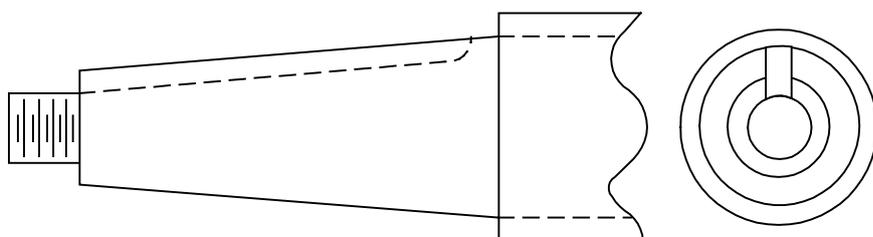

VISUAL AND OTHER TESTS
 (Preface indication Nos. with “V”)

Details of Ultrasonic Technique

May be omitted if data was previously submitted

1. Basic instrument

Brand and type

Date calibrated

Calibration method (Indicate specification (ASTM-E317-XX, etc.)

Calibration criteria (Describe or indicate specification Mil-STD-0900-3010, etc.)

2. Transducers

Brand & model No.	Frequency (MHz)	Type (Shear or compression)	Angle size	Applicability* (Flat or contoured)

3. Couplant

4. Calibration block(s) (Include sketch(es) and indicate position(s) of transducer(s) and sound path(s))

5. Calibration settings

	Transducer	
	Compression	Shear
Distance calibration for full screen with display		
Sensitivity calibration (Indicate % full screen height or decibel level which corresponds to reference notch of calibration)		
Scanning level adjustment (Indicate % full screen height or decibel level used in scanning)		

* Indicate surface contours in range of diameters or "F" if flat.

PART 7

APPENDIX

SECTION 12 Ultrasonic Examination of Carbon Steel Forgings for Tail Shafts (2013)

Note: (2013) This Appendix contains ABS standards for ultrasonic examination of new carbon steel forgings for tail shafts with a finished diameter of 455 mm (18 in.) and over. Conformity with this Appendix's procedures and acceptance standards, or equivalent is considered to meet ABS's requirements for the Ultrasonic Examination for Tail Shafts in the *ABS Rules for Building and Classing Steel Vessels*. Pertinent sections of ASTM A 388 (Standard Practice for the Ultrasonic Examination of Heavy Steel Forgings) referenced throughout this Appendix are included as an Annex to this Appendix.

Ultrasonic examination for tail shafts greater than or equal to 200 mm (8 in.) and less than 455 mm (18 in.) in diameter are to be carried out in accordance with Appendix 7 of the *ABS Rules for Materials and Welding (Part 2)*.

1 Scope

This Appendix is intended to clarify the ultrasonic examination requirement of the *ABS Rules for Building and Classing Steel Vessels*, which requires verification that tail shaft forgings are free from major internal discontinuities. This Appendix applies to new forgings for solid shafts with a finished diameter 455 mm (in.) and over and hollow shafts 455 mm (18 in.) and over which have an outside to inside diameter ratio of 2 to 1 or greater. Procedure and acceptance criteria for hollow shafts 455 mm (18 in.) and over with an outside to inside diameter ratio smaller than 2 to 1 will be specially considered.

Verification for freedom from surface discontinuities is provided by the *ABS Rules for Building and Classing Steel Vessels*, which requires examination by Magnetic Particle, Dye Penetrant or equivalent methods.

3 Applicable Documents (2010)

The recommended practices and standards contained in Section 2 of ASTM A 388 or other equivalent standard are applicable to this Appendix.

5 Documentation

Copies of the manufacturer's specific ultrasonic procedures and acceptance criteria intended to comply with this Appendix are to be submitted to the ABS Materials Department for approval and record purposes.

7 Apparatus and Technique (2010)

Apparatus is to comply with the following requirements

- i) Instruments are to be in accordance with Paragraphs 5.1, 5.1.1 of ASTM A 388 or other equivalent standard.
- ii) An ultrasonic examination for radial scanning is to be conducted using a straight beam nominal 1 MHz search unit. Use of a 2¹/₄ MHz search unit is permissible. However, in case of a dispute, results obtained with a 1 MHz search unit will govern. For longitudinal scans through the shaft axis, examination with a 1 MHz search unit is to be conducted. Search units having transducers with a maximum active area of 645 mm² (1 in²) with 19 mm (3/4 in.) minimum to 29 mm (1 1/8 in.) maximum dimension are to be used for both radial scanning and longitudinal scanning through the shaft axis.
- iii) Couplants are to be in accordance with Paragraph 5.3 of ASTM A 388 or other equivalent standard.
- iv) Reference blocks are to be used for calibration of equipment in accordance with Paragraph 5.1.1 of ASTM A 388 or other equivalent standard.

9 Personnel Requirements (2016)

Personnel responsible for conducting ultrasonic tests are to be thoroughly familiar with the equipment being used and be properly qualified by training and experience to perform the necessary calibrations and tests, and to interpret and evaluate indications in accordance with the terms of the Appendix. Periodic re-evaluations of test personnel are to be conducted to verify that such capability is maintained. Personnel qualified in accordance with the American Society for Nondestructive Testing-Publication SNT-TC-1A Table 1C, Ultrasonic Testing Method, ANSI/ASNT CP-106, or ISO 9712 are considered to meet this requirement. The requirements of other recognized agencies will be specially considered. Criteria are to verify that personnel are qualified by a combination of training and experience appropriate to the level of responsibility assigned.

11 Preparation of Forging for Ultrasonic Examination

The ends of the forging are to be machined perpendicular to the axis of the forging for longitudinal scans through the shaft axis. The surface roughness of exterior finishes to be ultrasonically scanned is not to exceed $6.35\ \mu\text{m}$ (250 $\mu\text{in.}$). The surfaces of the forging to be examined are to be free of extraneous material such as loose scale, paint, dirt, etc.

13 Procedure (2010)

Ultrasonic examination may be performed any time after final heat treatment for mechanical properties exclusive of stress relief treatments and is to take into account that the criteria of 7-A-12/Table 1 refer to finished dimensions. The ultrasonic examination is to be conducted using straight beam scanning. Unless specially indicated in the Appendix, the general procedures of Section 8 of ASTM A 388 or other equivalent standard apply.

13.1 Coverage

Coverage along the length of the shaft is to be in accordance with 7-A-12/Figures 1 and 2. Each end of the shaft (end views A-A/B-B or C-C/D'-D' of 7-A-12/Figure 1) is to be subjected to complete coverage. The scanning paths are to be equivalent to those detailed in 7-A-12/Figures 2 and 3. Where complete coverage is required by 7-A-12/Figure 1 or 7-A-12/17.3, the search unit is to be indexed with at least 15% overlap with each pass. Scanning rate is not to exceed 150 mm/s (6 in/s).

13.3 Radial Scanning (2010)

The instrument sensitivity is to be established by the back-reflection technique. With the attenuator set at an appropriate level, the instrument controls are to be adjusted to obtain a back-reflection reference level of approximately 80% of the full-screen height from the opposite surface of the forging in an area free of indications. The forging is to be scanned at the maximum amplification setting of the attenuator which does not produce excessive noise. The evaluation of discontinuities is to be carried out with the gain control setting at the 80% reference level.

Appropriate resetting of the 80% back-reflection reference level is required for significant changes in section thickness or diameter. The ultrasonic examination is to be performed prior to machining the taper, unless approved otherwise. When entry and back surfaces are not parallel, the instrument setting is to be calibrated for the maximum diameter of the section, unless otherwise approved. Recalibration is to be in accordance with Paragraph 8.2.3 of ASTM A 388 or other equivalent standard.

The instrument is to be equipped with an Automatic Distance Amplitude Correction (DAC). An instrument which does not automatically compensate for changes in signal amplitude with signal path length may be used, provided one of the following calibration methods is used:

- i) Recalibrate the instrument using the back reflection technique as per Paragraph 8.2.2.1 of ASTM A 388 or other equivalent standard, appropriate to each thickness being inspected.
- ii) Graphically calibrate the instrument by relating amplitude values of back reflection with changes in signal path length or increases of decibels with distance.
- iii) Calibration methods of other recognized specifications if submitted and approved.

13.5 Longitudinal Scanning Through Shaft Axis

A longitudinal scan through each end of the shaft axis is to be conducted using a 1 MHz transducer. The forging is to be scanned at the maximum amplification setting of the attenuator which does not produce excessive noise. Any indication is to be further investigated to determine that it does not exceed the criteria of 7-A-12/Table 1 in any orientation. Radial scanning using a straight beam technique or appropriate shear wave techniques are to be conducted to account for these indications.

15 Recording

The indications described in 7-A-12/15.1 are to be recorded with the gain control setting at the 80% reference level. For instruments not equipped with an automatic DAC feature, the indications are to be suitably corrected in accordance with 7-A-12/13.3i), ii), or iii). When discontinuities are indicated, the search unit is to be positioned so as to maximize the signal amplitude. The search unit is then to be moved parallel to the discontinuity and away from the position of maximum signal amplitude until the indication drops toward the base line. Using the center of the search unit as an index, the extremity points of the discontinuities are defined as the points where the signal amplitude either remains below the criteria as per 7-A-12/Table 1 for a distance equal to one-half the major dimension of the transducer or drops to one-half the maximum signal amplitude, whichever occurs first. For radial scanning, an appropriate correction is to be made to the arc length measurement of an indication on the circumference, so that it will represent the equivalent arc length of the indication at a given depth, i.e., at midradius the actual length of indication is one-half the length measured at the surface.

15.1 Recordable Indication

15.1.1

Individual indications equal to or exceeding 20% of screen height from an adjacent area free from indications.

15.1.2

Indications equal to or exceeding 15% of screen height, provided that they are traveling, planar or clusters, as defined in 7-A-12/15.1.3.

15.1.3

A reduction in back-reflection to a level of 50% screen height or less, except where the observed loss of back-reflection is attributable to non-parallel entry and back surfaces or other geometric considerations.

15.3 Definitions

The following definitions are illustrated in 7-A-12/Figure 4.

15.3.1 Traveling Indication

A *Traveling Indication* is an indication whose leading edge moves a distance equivalent to 25.4 mm (1 in.) or more of metal depth with movement of the search unit over the surface of the forging.

15.3.2 Planar Indication

A *Planar Indication* is an indication in the same plane which has a major axis greater than 25.4 mm (1 in.). Multiple planar indications on the same plane which are within any 1290 mm² (2 in²) area are to be considered as a single planar indication of a size equivalent to the length or area which encompasses all indications.

15.3.3 Cluster

A *Cluster* is defined as five (5) or more indications located in a volume representing a 51 mm (2 in.) cube in the forging.

17 Reports

17.1 Report Content (2010)

Reports are to be in accordance with Section 10 of ASTM A 388 or other equivalent standard, except for 10.1.1, in the Annex to this Section; for recordable indications, see 7-A-12/15.1 above. The paths of the longitudinal scans through the shaft axis (see 7-A-12/Figure 3, Detail E) are to be indicated on the required sketch which shows the locations of recordable indications.

17.3 Reporting of Indications Beyond Acceptance Levels

Indications beyond the acceptance quality level of 7-A-12/Table 1 are to be submitted to the ABS Materials Department for special consideration. The submission is to include an interpretation of the nature, location and distribution of the discontinuity indicated; the results of supplementary ultrasonic examination using shear wave techniques may be used to support the interpretation. The examination of sections where complete radial coverage is not required, is intended to verify the core soundness of the shaft and the criteria in column B are applicable. However, when any recordable indication from the outer half radius exceeds a criterion of column A, the shaft is to be subjected to complete coverage.

TABLE 1
Acceptance Quality Levels (1, 2, 3, 4) (Radial Scanning) for Tail Shaft Forgings

<i>Recordable Indication⁽⁵⁾</i>	<i>A Outer Half Radius Finished Diameter</i>	<i>B Inner Half Radius Finished Diameter</i>
Traveling (7-A-12/15.3.1) (Greater than 15%)	25.4 mm (1 in.)	51 mm (2 in.)
Planar (7-A-12/15.3.2) (Greater than 15%)	150 mm (6 in.) or 1290 mm ² (2 in ²)	300 mm (12 in.) or 2580 mm ² (4 in ²)
Cluster (7-A-12/15.3.3) (Greater than 15%)	1 cluster	2 clusters separated by 51 mm (2 in.) or less
Loss of Back Reflection (7-A-12/15.1.3)	See Note 2	51 mm (2 in.) Max. in any dimension traversed

Notes

- 1 Columns A and B represent the maximum allowable discontinuity length, area or volume.
- 2 In all cases, an indication must be reported to account for a reduction in back-reflection where screen height level is below 50% (see 7-A-12/15.1.3 of this Appendix for non-parallel surfaces). No reportable indication related to this reduction in back-reflection is permitted within the outer half radius unless it is established that the reduction is not associated with the indication.
- 3 When ultrasonic examination is conducted prior to finish machining, appropriate allowance is to be made for the fact that 7-A-12/Table 1 applies to finished dimensions (see 7-A-12/13).
- 4 All dimensions represent values corrected in accordance with 7-A-12/13.3 and 7-A-12/15.
- 5 Individual indications recorded as per 7-A-12/15.1 are to be subjected to appropriate supplementary ultrasonic examination using shear wave techniques to verify that the criteria of 7-A-12/Table 1 are not exceeded.

FIGURE 1
Extent of Ultrasonic Examination

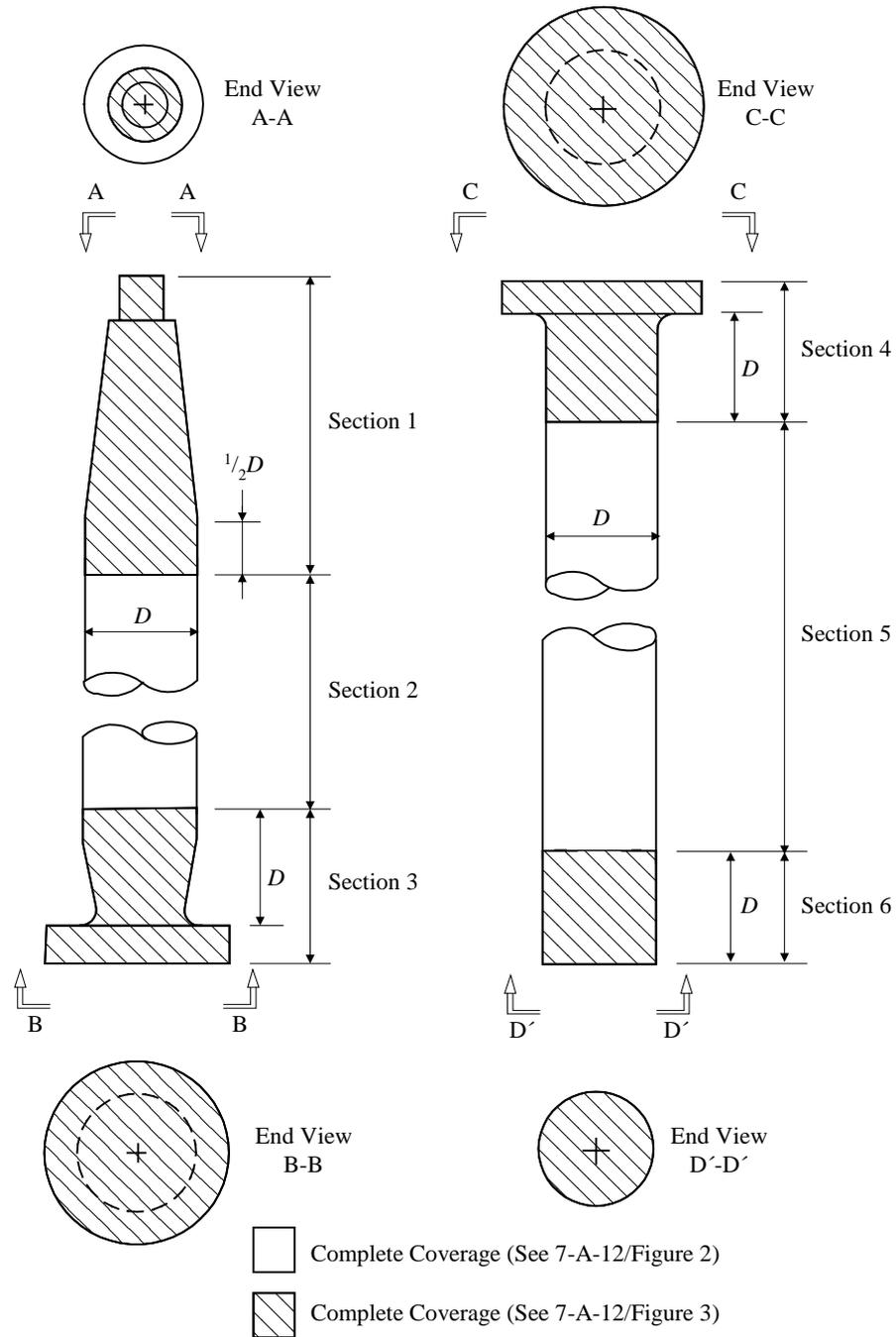

FIGURE 2
Coverage for Sections 2 and 5 of 7-A-12/Figure 1

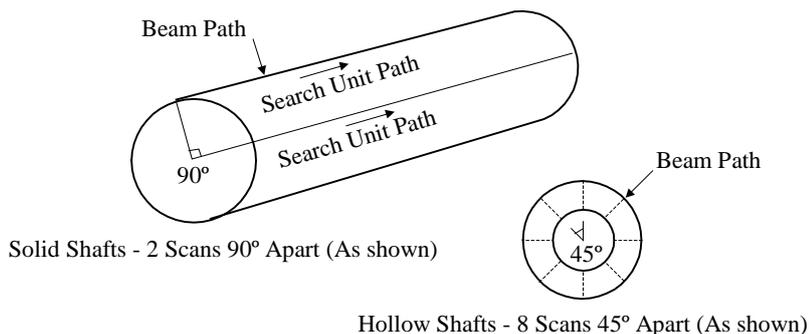
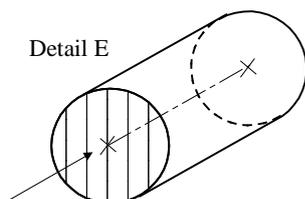
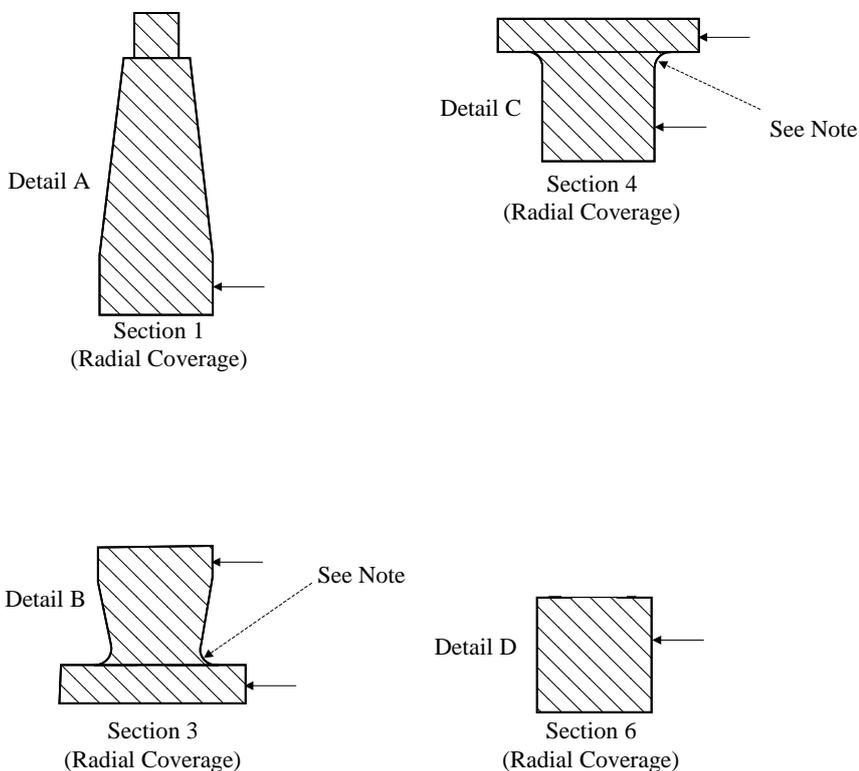

FIGURE 3
Coverage for Sections 1, 3, 4, and 6 of 7-A-12/Figure 1

→ Indicates Beam Path



End View (A-A/B-B/C-C/D'-D') of 7-A-12/Figure 1
 For Longitudinal Scans through the Shaft Axis

Note Coverage may be omitted if curvature is excessive for flat transducer

FIGURE 4
Typical Discontinuities

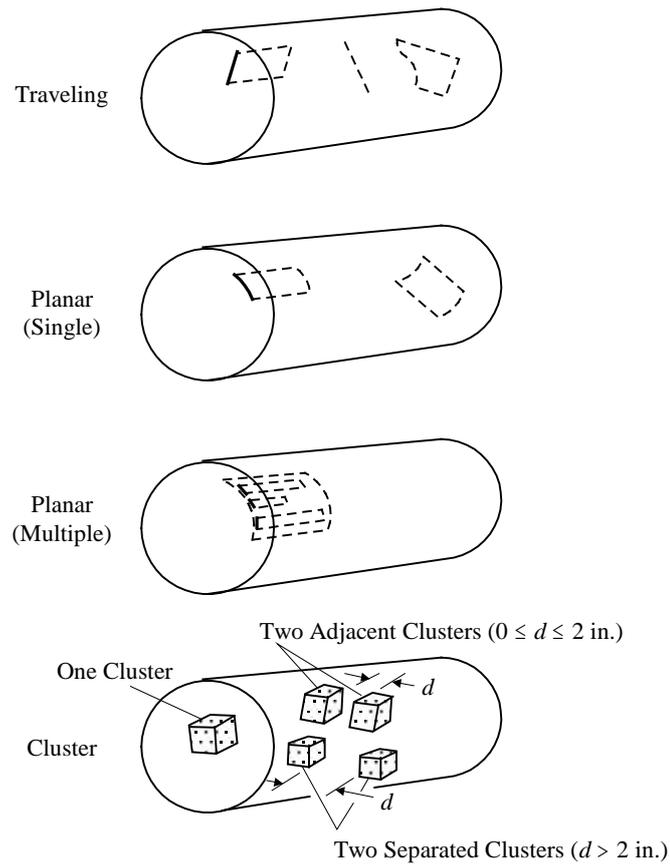

Annex Pertinent Sections of ASTM A388 Referenced in the Appendix (2010)

Note: Excerpted from the Annual Book of ASTM Standards, A388. Copyright, ASTM, 100 Barr Harbor Drive, West Conshohocken, PA 19428 This standard is available from ASTM.

2. Documents

2.1 ASTM Standards:

- E 317 Recommended Practice for Evaluating Performance Characteristics of Ultrasonic Pulse-Echo Testing Systems Without the Use of Electronic Measurement Instruments³
- E 428 Recommended Practice for Fabrication and Control of Metal, other than Aluminum, Reference Blocks Used in Ultrasonic Inspection³

2.2 Other Documents:

- Recommended Practice for Nondestructive Personnel Qualification and Certification SNT-TC-IA⁴
- ANSI B46.1, Surface Textures⁵

3 Annual Book Of ASTM Standards, Part II.

4 Available from the American Society for Nondestructive Testing., 1711 Arlingate Lane, P.O. Box 28518, Columbus, OH 43228-0518

5 Available from the American National Standards Institute, Inc. 25 W 43rd Street, 4th Floor, New York, NY 10036.

⁵Current address 1983: 3200 Riverside Drive, Columbus, Ohio 43221.

5. Apparatus

5.1 An ultrasonic, pulsed, reflection type of instrument shall be used for this examination. The system shall have a minimum capability for examining at frequencies from 1 to 5 MHz. On examining austenitic stainless forgings, the system shall have the capabilities for examining at frequencies down to 0.4 MHz.

5.1.1 The ultrasonic instrument shall provide linear presentation (within 5%) for at least 75% of the screen height (sweep line to top of screen). The 5% linearity referred to is descriptive of the screen presentation of amplitude. Instrument linearity shall be verified in accordance with the intent of Recommended Practice E 317. Any set of blocks processed in accordance with Recommended Practices E 317 or E 428 may be used to establish the specified $\pm 5\%$ instrument linearity.

5.3 Couplants having good wetting characteristics such as SAE No. 20 or No. 30 motor oil, glycerin, pine oil or water shall be used. Couplants may not be comparable to one another and the same couplant shall be used for calibration and examination.

8. Procedure

8.1 General:

8.1.1 As far as practicable, subject the entire volume of the forging to ultrasonic examination. Because of radii at change of sections and other local configurations, it may be impossible to examine some sections of a forging.

8.1.2 Perform the ultrasonic examination after heat treatment for mechanical properties (exclusive of stress-relief treatments), but prior to drilling holes, cutting keyways, tapers, grooves or machining sections to contour. If the configuration of the forging required for the treatment for mechanical properties prohibits a subsequent complete examination of the forging, it shall be permissible to examine prior to treatment for mechanical properties. In such cases, re-examine the forging ultrasonically as completely as possible after heat treatment.

8.1.3 To assure complete coverage of the forging volume, index the search unit with at least 15% overlap with each pass.

8.1.4 Do not exceed a scanning rate of 6 in./s (152.4 mm/s).

8.1.5 For automated scanning, adjust scanning speed or instrument repetition rate, or both, to permit detection of the smallest discontinuities referenced in the specification and to allow the recording or signaling device to function. At no time shall the scanning speed exceed the speed at which an acceptable calibration was made.

8.1.6 If possible, scan all sections of forgings in two perpendicular directions.

8.1.7 Scan disk forgings using a straight beam from at least one flat face and radially from the circumference, whenever practicable.

8.1.8 Scan cylindrical sections and hollow forgings radially using a straight-beam technique. When practicable, also examine the forging in the axial direction.

8.1.9 In addition, examine hollow forgings by angle-beam technique from the outside diameter surface as required in 8.3.1.

8.1.10 In rechecking or re-evaluation by manufacturer or purchaser, use comparable equipment, search units, frequency and couplant.

8.1.11 Forgings may be examined either stationary or while rotating in a lathe or on rollers. If not specified by the purchaser, either method may be used at the manufacturer's option.

8.2 Straight-Beam Examination:

8.2.1 For straight-beam examination, use a nominal $2\frac{1}{4}$ MHz search unit wherever practicable; however, 1 MHz is the preferred frequency for coarse grained austenitic materials and long testing distances. In many instances on examining coarse grained austenitic materials, it may be necessary to use a frequency of 0.4 MHz. Other frequencies may be used if desirable for better resolution, penetrability or detectability of flaws.

8.2.2 Establish the instrument sensitivity by either the back reflection, reference-block technique, or DGS method (see ASTM A 388 appendix X3 for an explanation of the DGS method).

8.2.2.1 *Back-Reflection Technique (Back-Reflection Calibration Applicable to Forgings with Parallel Entry and Back Surfaces)* With the attenuator set at an appropriate level, for example, 5 to 1 or 14 dB, adjust the instrument controls to obtain a back reflection approximately 75% of the full-screen height from the opposite side of the forging. Scan the forging at the maximum amplification setting of the attenuator (attenuator set at 1 to 1). Carry out the evaluation of discontinuities with the gain control set at the reference level. Recalibration is required for significant changes in section thickness or diameter.

Note 1 High sensitivity levels are not usually employed when inspecting austenitic steel forgings due to attendant high level of "noise" or "hash" caused by coarse grain structure.

8.2.2.2 *Reference-Block Calibration* The test surface roughness on the calibration standard shall be comparable to but no better than the item to be examined. Adjust the instrument controls to obtain the required signal amplitude from the flat-bottom hole in the specified reference block. Utilize the attenuator in order to set up on amplitudes larger than the vertical linearity of the instrument. In those cases, remove the attenuation prior to scanning the forging.

Note 2 When flat-surfaced reference block calibration is specified, adjust the amplitude of indication from the reference block or blocks to compensate for examination surface curvature.

8.2.3 *Recalibration.* Any change in the search unit, couplant, instrument setting or scanning speed from that used for calibration shall require recalibration. Perform a calibration check at least once every 8 h shift. When a loss of 15% or greater in the gain level is indicated, re-establish the required calibration and re-examine all of the material examined in the preceding calibration period. When an increase of 15% or greater in the gain level is indicated, re-evaluate all recorded indications.

8.2.4 During the examination of the forging, monitor the back reflection for any significant reduction in amplitude. Reduction in back-reflection amplitude may indicate not only the presence of a discontinuity but also poor coupling of the search unit with the surface of the forging, nonparallel back-reflection surface or local variations of attenuation in the forging. Recheck any areas causing loss of back reflection.

8.3 Angle-Beam Examination-Rings and Hollow Forgings:

8.3.1 Perform the examination from the circumference of rings and hollow forgings that have an axial length greater than 2 in. (50.8 mm) and an outside to inside diameter ratio of less than 2.0 to 1.

8.3.2 Use a 1 MHz, 45° angle-beam search unit unless thickness, OD/ID ratio, or other geometric configuration results in failure to achieve calibration. For angle-beam inspection of hollow forgings up to 2.0 to 1 ratio, provide the transducer with a wedge or shoe that will result in the beam mode and angle required by the size and shape of the cross section under examination.

8.3.3 Calibrate the instrument for the angle-beam examination to obtain an indication amplitude of approximately 75% full-screen height from a rectangular or 60° V-notch on inside diameter (ID) in the axial direction and parallel to the axis of the forging. A separate calibration standard may be used; however, it shall have the same nominal composition, heat treatment and thickness as the forging it represents. The test surface finish on the calibration standard shall be comparable, but no better than the item to be examined. Where a group of identical forgings is made, one of these forgings may be used as the separate calibration standard. Cut the ID notch depth to 3% maximum of the thickness or 1/4 in. (6.35 mm), whichever is smaller, and its length approximately 1 in. (25 mm). Thickness is defined as the thickness of the forging to be examined at the time of examination. At the same instrument setting obtain a reflection from a similar OD notch. Draw a line through the peaks of the first reflections obtained from the ID and OD notches. This shall be the amplitude reference line. It is preferable to have the notches in excess metal or test metal when possible. When the OD notch cannot be detected when examining the OD surface, perform the examination, when practicable (some ID's may be too small to permit examination), as indicated above from both the OD and ID surfaces utilizing the ID notch when inspecting from the OD, and the OD notch when inspecting from the ID. Curve wedges or shoes may be used when necessary and practicable.

8.3.4 Perform the examination by scanning over the entire surface area circumferentially in both the clockwise and counterclockwise directions from the OD surface. Examine forgings, which cannot be examined axially using a straight beam, in both axial directions with an angle-beam search unit. For axial scanning, use rectangular or 60° V-notches on the ID and OD for the calibration. These notches shall be perpendicular to the axis of the forging and the same dimensions as the axial notch.

10. Report

10.1 The report shall include the following:

10.1.1 All recordable indications (see Section 9).

10.1.2 For the purpose of reporting the locations of recordable indications, a sketch shall be prepared showing the physical outline of the forging including dimensions of all areas not inspected due to geometric configuration, the purchaser's drawing number, the purchaser's order number, and the manufacturer's serial number, and the axial, radial and circumferential distribution of recordable ultrasonic indications.

10.1.3 The designation (including year date) to which the examination was performed as well as the frequency used, method of setting sensitivity, type of instrument, surface finish, couplant and search unit employed.

10.1.4 The inspector's name or identity and date examination performed.

PART

7

APPENDIX

SECTION 13 Report on Thickness Measurement of Oil Carriers – Double Hull (CSR and Non-CSR Vessels) (1 July 2013)

1 Instructions

1.1 Non-CSR Vessels

1.1.1

This document is to be used for recording thickness measurements as required by the Enhanced Survey Program (see 7-3-2/5.14.5).

1.1.2

Reporting forms TM1-DHT, TM2-DHT, TM3-DHT, TM4-DHT, TM5-DHT and TM6-DHT are to be used for recording thickness measurements and the maximum allowable diminution is to be stated.

1.1.3

7-A-13/Figures 1 through 5 are guidance diagrams and notes relating to the reporting forms and the procedure for thickness measurements of Oil Carriers – Double Hull.

1.3 CSR Vessels

1.3.1

This document is to be used for recording thickness measurements of double hull oil tankers built under IACS Common Structural Rules (CSR) as required by the IACS Unified Requirement Z10.4.

1.3.2

Reporting forms TM1-DHT(CSR), TM2-DHT(CSR) (i) and (ii), TM3-DHT(CSR), TM4-DHT(CSR), TM5-DHT(CSR) and TM6-DHT(CSR) are to be used for recording thickness measurements.

1.3.3

The as-built thickness and voluntary thickness addition and renewal thickness (minimum allowable thickness) are to be stated in the said forms.

1.3.4

7-A-13/Figures 1 through 5 are guidance diagrams and notes relating to the reporting forms and the IACS unified Requirements for thickness measurement.

1.3.5

7-A-13/Figures 6 through 9 and 7-A-13/Table 1 are guidance diagrams and notes relating to the rule requirements for the locations and number of points to be measured for CSR double hull oil tankers.

1.5 Reporting Forms

The reporting forms should, where appropriate, be supplemented by data presented on structural sketches.

General Particulars

Ship's name:

IMO number:

ABS identification number:

Port of registry:

Gross tons:

Deadweight:

Date of build:

Classification society:

Name of Company performing thickness measurement:

Thickness measurement company certified by:

Certificate No.:

Certificate valid from _____ to _____

Place of measurement:

First date of measurement:

Last date of measurement:

Special survey/intermediate survey due: *

Details of measurement equipment:

Qualification of operator:

Report Number:	consisting of	Sheets
----------------	---------------	--------

Name of operator:		Name of surveyor:
_____		_____

Signature of operator:		Signature of surveyor:
_____		_____

Company official stamp:		Classification Society Official Stamp:
_____		_____

*Delete as appropriate.

TM1-DHT (1 July 2006)

Report on THICKNESS MEASUREMENT of ALL DECK PLATING, ALL BOTTOM SHELL PLATING or SIDE SHELL PLATING*
 (* delete as appropriate)

Ship's Name _____ Class Identity No. _____ Report No. _____

STRAKE POSITION	PLATE POSITION	No. or Letter	Org thk mm	Forward Reading						Aft Reading						Mean Diminution %		Max. Alwb. Dim. mm
				Gauged		Diminution P		Diminution S		Gauged		Diminution P		Diminution S		P	S	
				P	S	mm	%	mm	%	P	S	mm	%	mm	%			
12th forward																		
11th																		
10th																		
9th																		
8th																		
7th																		
6th																		
5th																		
4th																		
3rd																		
2nd																		
1st																		
Amidships																		
1st aft																		
2nd																		
3rd																		
4th																		
5th																		
6th																		
7th																		
8th																		
9th																		
10th																		
11th																		
12th																		

Operators Signature _____

NOTES - See Reverse

NOTES

1. This report is to be used for recording the thickness measurement of:
 - 1.1 All strength deck plating within the cargo area.
 - 1.2 All keel, bottom shell plating and bilge plating within the cargo area.
 - 1.3 Side shell plating, including selected wind and water strakes outside 0.5L amidships.
2. The strake position is to be clearly indicated as follows:
 - 2.1 For strength deck, indicate the number of the strake of plating inboard from the stringer plate.
 - 2.2 For bottom plating, indicate the number of the strake of plating outboard from the keel plate.
 - 2.3 For side shell plating, give number of the strake of plating below sheerstrake and letter as shown on shell expansion.
3. Measurements are to be taken at the forward and aft areas of all plates, and where plates cross ballast/ cargo tank boundaries, separate measurements for the area of plating in way of each type of tank are to be recorded.
4. The single measurements recorded are to represent the average of multiple measurements.
5. The maximum allowable diminution could be stated in an attached document.

TM2-DHT (i) (1 July 2006)

Report on THICKNESS MEASUREMENT of SHELL AND DECK PLATING (one, two or three transverse sections)

Ship's Name _____ Class Identity No. _____ Report No. _____

STRENGTH DECK AND SHEERSTRAKE PLATING																												
STRAKE POSITION	FIRST TRANSVERSE SECTION AT FRAME								SECOND TRANSVERSE SECTION AT FRAME								THIRD TRANSVERSE SECTION AT FRAME											
	No. or Ltr	Org Thk mm	Max Alwb Dim. mm	Gauged		Diminution P		Diminution S		No. or Ltr	Org Thk mm	Max Alwb Dim. mm	Gauged		Diminution P		Diminution S		No. or Ltr	Org Thk mm	Max Alwb Dim. mm	Gauged		Diminution P		Diminution S		
				P	S	mm	%	mm	%				P	S	mm	%	mm	%				P	S	mm	%	mm	%	
Stringer Plate																												
1st strake Inboard																												
2nd																												
3rd																												
4th																												
5th																												
6th																												
7th																												
8th																												
9th																												
10th																												
11th																												
12th																												
13th																												
14th																												
centre strake																												
sheer strake																												
TOPSIDE TOTAL																												

Operators Signature _____

NOTES - See Reverse

NOTES

1. This report form is to be used for recording the thickness measurement of:
Strength deck plating and sheerstrake plating transverse sections:
One, two or three sections within the cargo area comprising the structural items (0), (1) and (2), as shown on the diagrams of typical transverse sections (See 7-A-13/Figures 1 and 2).
The topside area comprises deck plating, stringer plate and sheerstrake (including rounded gunwales).
2. The exact frame station of measurement is to be stated.
3. The single measurements recorded are to represent the average of multiple measurements.
4. The maximum allowable diminution could be stated in an attached document.

TM2-DHT (ii) (1 July 2006)

Report on THICKNESS MEASUREMENT of SHELL AND DECK PLATING (one, two or three transverse sections)

Ship's Name _____ Class Identity No. _____ Report No. _____

SHELL PLATING																											
STRAKE POSITION	FIRST TRANSVERSE SECTION AT FRAME NUMBER								SECOND TRANSVERSE SECTION AT FRAME NUMBER								THIRD TRANSVERSE SECTION AT FRAME NUMBER										
	No. or Ltr	Org Thk mm	Max Alwb Dim. mm	Gauged		Diminution P		Diminution S		No. or Ltr	Org Thk mm	Max Alwb Dim. mm	Gauged		Diminution P		Diminution S		No. or Ltr	Org Thk mm	Max Alwb Dim. mm	Gauged		Diminution P		Diminution S	
				P	S	mm	%	mm	%				P	S	mm	%	mm	%				P	S	mm	%	mm	%
1st below sheer strake																											
2nd																											
3rd																											
4th																											
5th																											
6th																											
7th																											
8th																											
9th																											
10th																											
11th																											
12th																											
13th																											
14th																											
15th																											
16th																											
17th																											
18th																											
19th																											
20th																											
keel strake																											
BOTTOM TOTAL																											

Operators Signature _____

NOTES - See Reverse

NOTES

1. This report is to be used for recording the thickness measurements of:
Shell plating transverse sections:
One, two or three sections within the cargo area comprising the structural items (3), (4) and (5), as shown on the diagrams of typical transverse sections (See 7-A-13/Figures 1 and 2).
2. The bottom area comprises keel, bottom and bilge plating.
3. The exact frame station of measurement is to be stated.
4. The single measurements recorded are to represent the average of multiple measurements.
5. The maximum allowable diminution could be stated in an attached document.

NOTES

1. This report is to be used for recording the thickness measurement of:
Longitudinal Members at transverse sections:
One, two or three sections within the cargo area comprising the appropriate structural items (10) to (29), as shown on the diagrams of typical transverse sections (See 7-A-13/Figures 1 and 2).
2. The exact frame station of measurement is to be stated.
3. The single measurements recorded are to represent the average of multiple measurements.
4. The maximum allowable diminution could be stated in an attached document.

TM4-DHT (1 July 2006)

Report on THICKNESS MEASUREMENT OF TRANSVERSE STRUCTURAL MEMBERS
In the cargo oil and water ballast tanks within the cargo tank length

Ship's Name _____ Class Identity No. _____ Report No. _____

TANK DESCRIPTION :									
LOCATION OF STRUCTURE :									
STRUCTURAL MEMBER	ITEM	Original Thickness mm	Maximum Allowable Diminution mm	Gauged		Diminution P		Diminution S	
				Port	Starboard	mm	%	mm	%

Operators Signature _____

NOTES - See Reverse

NOTES

1. This report is to be used for recording the thickness measurement of transverse structural members, comprising the appropriate structural items (30) to (36), as shown on diagrams of typical transverse section (See 7-A-13/Figures 1 and 2).
2. Guidance for areas of measurement is indicated on 7-A-13/Figures 4 and 5.
3. The single measurements recorded are to represent the average of multiple measurements.
4. The maximum allowable diminution could be stated in an attached document.

TM5-DHT (1 July 2006)

Report on THICKNESS MEASUREMENT OF W.T./O.T. TRANSVERSE BULKHEADS
within the cargo tank or cargo hold spaces

Ship's Name _____ Class Identity No. _____ Report No. _____

TANK/HOLD DESCRIPTION :								
LOCATION OF STRUCTURE :				FRAME NO. :				
STRUCTURAL COMPONENT (PLATING/STIFFENER)	Original Thickness mm	Maximum Allowable Diminution mm	Gauged		Diminution P		Diminution S	
			Port	Starbd	mm	%	mm	%

Operators Signature _____

NOTES - See Reverse

NOTES

1. This report form is to be used for recording the thickness measurement of W.T./O.T. transverse bulkheads.
2. Guidance for areas of measurement is indicated on 7-A-13/Figure 4.
3. The single measurements recorded are to represent the average of multiple measurements.
4. The maximum allowable diminution could be stated in an attached document.

TM6-DHT (1 July 2006)

Report on THICKNESS MEASUREMENT OF MISCELLANEOUS STRUCTURAL MEMBERS

Ship's Name _____ Class Identity No. _____ Report No. _____

STRUCTURAL MEMBER :							SKETCH			
LOCATION OF STRUCTURE :										
Description	Org Thk. mm	Maximum Allowable Diminution mm	Gauged		Diminution P		Diminution S			
			P	S	mm	%	mm	%		

Operators Signature _____

NOTES - See Reverse

NOTES

1. This report is to be used for recording the thickness measurement of miscellaneous structural members
2. The single measurements recorded are to represent the average of multiple measurements.
3. The maximum allowable diminution could be stated in an attached document.

TM1-DHT(CSR) (1 July 2013)

Report on THICKNESS MEASUREMENT of ALL DECK PLATING, ALL BOTTOM PLATING or SIDE SHELL PLATING*
 (* delete as appropriate)

Ship's Name _____

Class Identity No. _____

Report No. _____

STRAKE POSITION																
	PLATE POSITION	No. or Letter	As Built Thk. mm	Voluntary Thickness Addition mm	Renewal Thickness mm (a)	Forward Reading				Aft Reading				Mean Remaining Corr. Addition, mm [(c1) + (c2)]/2		
						Gauged Thk. mm (b1)		Remaining Corr. Addition, mm (c1) = (b1) - (a)		Gauged Thk. mm (b1)		Remaining Corr. Addition, mm (c1) = (b1) - (a)		P	S	
						P	S	P	S	P	S	P	S	P	S	
12th forward																
11th																
10th																
9th																
8th																
7th																
6th																
5th																
4th																
3rd																
2nd																
1st																
Amidships																
1st aft																
2nd																
3rd																
4th																
5th																
6th																
7th																
8th																
9th																
10th																
11th																
12th																

Operators Signature _____

NOTES - See Reverse

NOTES TO REPORT TM1-DHT(CSR)

1. This report is to be used for recording the thickness measurement of:
 - 1.1 All strength deck plating within cargo length area.
 - 1.2 All keel, bottom shell plating and bilge plating within the cargo length area.
 - 1.3 Side shell plating including selected wind and water strakes outside the cargo length area.
 - 1.4 All wind and water strakes within the cargo length area.
2. The strake position is to be clearly indicated as follows:
 - 2.1 For strength deck indicate the number of the strake of plating inboard from the stringer plate.
 - 2.2 For bottom plating indicate the number of the strake of plating outboard from the keel plate.
 - 2.3 For side shell plating give number of the strake of plating sheerstrake and letter as shown on shell expansion.
3. Measurements are to be taken at the forward and aft areas of all plates cross ballast/cargo tank boundaries separate measurements for the area of plating in way of each type of tank are to be recorded.
4. The single measurements recorded are to represent the average of multiple measurements.
5. The remaining corrosion addition is to be recorded with result of gauged thickness minus renewal thickness. If the result is negative, the structure in way shall be renewed, and the mark “R” is to be indicated in the right-hand column. If the result is between 0 and 0.5 mm (0 included), the structure in way shall be additional gauged, and the mark “S” is to be indicated in the right-hand column.

NOTES TO REPORT TM2-DHT(CSR) (i)

1. This report is to be used for recording the thickness measurement of:
Strength deck plating and sheerstrake plating transverse sections:
One, two or three sections within the cargo length area, comprising of the structural items (0), (1) and (2) as shown on the diagram of typical transverse sections, 7-A-13/Figure 1 and 2.
2. The topside area comprises deck plating, stringer plate and sheerstrake (including rounded gunwales).
3. The exact frame station of measurement is to be stated.
4. The single measurements recorded are to represent the average of multiple measurements.
5. The remaining corrosion addition is to be recorded with result of gauged thickness minus renewal thickness. If the result is negative, the structure in way shall be renewed, and the mark “R” is to be indicated in the right-hand column. If the result is between 0 and 0.5 mm (0 included), the structure in way shall be additional gauged, and the mark “S” is to be indicated in the right-hand column.

NOTES TO REPORT TM2-DHT(CSR) (ii)

1. This report is to be used for recording the thickness measurement of:
Shell plating transverse sections:
One, two or three sections within the cargo length area comprising of the structural items (3), (4) and (5) and (6) as shown on the diagram of typical transverse sections, 7-A-13/Figures 1 and 2.
2. The bottom area comprises keel, bottom and bilge plating.
3. The exact frame station of measurement is to be stated.
4. The single measurements recorded are to represent the average of multiple measurements.
5. The remaining corrosion addition is to be recorded with result of gauged thickness minus renewal thickness. If the result is negative, the structure in way shall be renewed, and the mark “R” is to be indicated in the right-hand column. If the result is between 0 and 0.5 mm (0 included), the structure in way shall be additional gauged, and the mark “S” is to be indicated in the right-hand column.

TM3-DHT(CSR) (1 July 2013)

Report on THICKNESS MEASUREMENT OF LONGITUDINAL MEMBERS (one, two or three transverse sections)

Ship's Name _____

Class Identity No. _____

Report No. _____

STRUCTURAL MEMBER	FIRST TRANSVERSE SECTION AT FRAME NUMBER								SECOND TRANSVERSE SECTION AT FRAME NUMBER								THIRD TRANSVERSE SECTION AT FRAME NUMBER							
	Item No.	As Built Thk. mm	Vol. Thk. Add mm	Ren. Thk. mm (a)	Gauged Thk. mm (b)		Remaining Corr. Addition, mm (b) – (a)		Item No.	As Built Thk. mm	Vol. Thk. Add mm	Ren. Thk. mm (a)	Gauged Thk. mm (b)		Remaining Corr. Addition, mm (b) – (a)		Item No.	As Built Thk. mm	Vol. Thk. Add mm	Ren. Thk. mm (a)	Gauged Thk. mm (b)		Remaining Corr. Addition, mm (b) – (a)	
					P	S	P	S					P	S	P	S					P	S	P	S

Operators Signature _____

NOTES - See Reverse

NOTES TO REPORT TM3-DHT(CSR)

1. This report is to be used for recording the thickness measurement of:
Longitudinal Members at transverse sections:
One, two or three sections within the cargo length area, comprising of the appropriate structural items (10) to (29) as shown on the diagram of typical transverse sections, 7-A-13/Figures 1 and 2.
2. The exact frame station of measurement is to be stated.
3. The single measurements recorded are to represent the average of multiple measurements.
4. The remaining corrosion addition is to be recorded with result of gauged thickness minus renewal thickness. If the result is negative, the structure in way shall be renewed, and the mark “R” is to be indicated in the right-hand column. If the result is between 0 and 0.5 mm (0 included), the structure in way shall be additional gauged, and the mark “S” is to be indicated in the right-hand column.

TM4-DHT(CSR) (1 July 2013)

Report on THICKNESS MEASUREMENT OF TRANSVERSE STRUCTURAL MEMBERS
In the cargo oil and water ballast tanks within the cargo tank length

Ship's Name _____ Class Identity No. _____ Report No. _____

TANK DESCRIPTION :									
LOCATION OF STRUCTURE :									
STRUCTURAL MEMBER	ITEM	As Built Thickness mm	Voluntary Thickness Addition mm	Renewal Thickness mm (a)	Gauged Thickness mm (b)		Remaining Corr. Addition mm (b) – (a)		
					P	S	P	S	S

Operators Signature _____

NOTES - See Reverse

NOTES TO REPORT TM4-DHT(CSR)

1. This report is to be used for recording the thickness measurement of transverse structural members, comprising of the appropriate structural items (30) to (36) as shown on diagram of typical transverse section, 7-A-13/Figures 1 and 2.
2. Guidance for areas if measurement is indicated on the diagrams shown on 7-A-13/Figures 4 and 5.
3. The single measurements recorded are to represent the average of multiple measurements.
4. The remaining corrosion addition is to be recorded with result of gauged thickness minus renewal thickness. If the result is negative, the structure in way shall be renewed, and the mark “R” is to be indicated in the right-hand column. If the result is between 0 and 0.5 mm (0 included), the structure in way shall be additional gauged, and the mark “S” is to be indicated in the right-hand column.

TM5-DHT(CSR) (1 July 2013)

Report on THICKNESS MEASUREMENT OF W.T./O.T. TRANSVERSE BULKHEADS
Within the cargo and ballast tanks

Ship's Name _____ Class Identity No. _____ Report No. _____

TANK DESCRIPTION :								
LOCATION OF STRUCTURE :				FRAME NO:				
STRUCTURAL COMPONENT (PLATING/STIFFENER)	As Built Thickness mm	Voluntary Thickness Addition mm	Renewal Thickness mm (a)	Gauged Thickness mm (b)		Remaining Corr. Addition mm (b) – (a)		
				P	S	P	S	

Operators Signature _____

NOTES - See Reverse

NOTES TO REPORT TM5-DHT(CSR)

1. This report is to be used for recording the thickness measurement of W.T./O.T. transverse bulkheads.
2. Guidance for areas of measurement is indicated on the diagrams shown on 7-A-13/Figure 4.
3. The single measurements recorded are to represent the average of multiple measurements.
4. The remaining corrosion addition is to be recorded with result of gauged thickness minus renewal thickness. If the result is negative, the structure in way shall be renewed, and the mark “R” is to be indicated in the right-hand column. If the result is between 0 and 0.5 mm (0 included), the structure in way shall be additional gauged, and the mark “S” is to be indicated in the right-hand column.

TM6-DHT(CSR) (1 July 2013)

Report on THICKNESS MEASUREMENT OF MISCELLANEOUS STRUCTURAL MEMBERS

Ship's Name _____ Class Identity No. _____ Report No. _____

STRUCTURAL MEMBER :						SKETCH							
LOCATION OF STRUCTURE :													
Description	As Built Thk. mm	Voluntary thickness Addition mm	Renewal Thickness mm (a)	Gauged Thickness mm (b)						Remaining Corr. Addition mm (b) – (a)			
				P	S					P	S	P	S

Operators Signature _____

NOTES - See Reverse

NOTES TO REPORT TM6-DHT(CSR)

1. This report is to be used for recording the thickness measurement of miscellaneous structural members.
2. The single measurements recorded are to represent the average of multiple measurements.
3. The remaining corrosion addition is to be recorded with result of gauged thickness minus renewal thickness. If the result is negative, the structure in way shall be renewed, and the mark “R” is to be indicated in the right-hand column. If the result is between 0 and 0.5 mm (0 included), the structure in way shall be additional gauged, and the mark “S” is to be indicated in the right-hand column.

FIGURE 1
Thickness Measurement – Oil Carriers – Double Hull (1 July 2013)
Typical transverse section of a double hull oil carrier up to 150,000 dwt
indicating longitudinal and transverse members

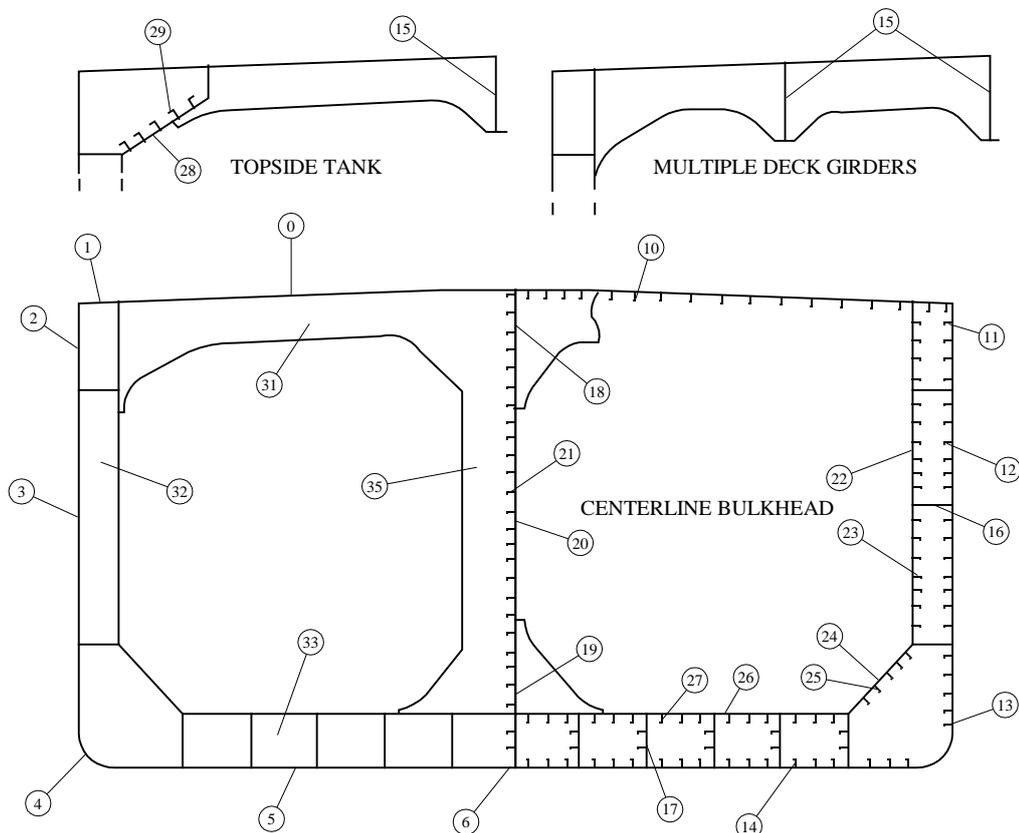

REPORT ON TM2-DHT (i) & (ii) or TM2-DHT(CSR) (i) & (ii)	REPORT ON TM3-DHT or TM3-DHT(CSR)		REPORT ON TM4-DHT or TM4-DHT(CSR)
<ul style="list-style-type: none"> 0. Strength deck plating 1. Stringer plate 2. Sheerstrake 3. Side shell plating 4. Bilge plating 5. Bottom shell plating 6. Keel plate 	<ul style="list-style-type: none"> 10. Deck longitudinals 11. Sheerstrake longitudinals 12. Side shell longitudinals 13. Bilge longitudinals 14. Bottom Longitudinals 15. Deck girders 16. Horizontal girders in wing ballast tanks 17. Bottom girders 18. Longitudinals bulkhead top strake 19. Longitudinals bulkhead bottom strake 	<ul style="list-style-type: none"> 20. Longitudinal bulkhead plating (remainder) 21. Longitudinal bulkhead longitudinals 22. Inner side plating 23. Inner side longitudinals 24. Hopper plating 25. Hopper longitudinals 26. Inner bottom plating 27. Inner bottom longitudinals 28. Topside tank plating 29. Topside tank longitudinals 	<ul style="list-style-type: none"> 30. Deck transverse center tank 31. Deck transverse wing tank 32. Vertical web in wing ballast tank 33. Double bottom floor – wing tank 34. Double bottom floor – center tank 35. Longitudinal bulkhead vertical web 36. Cross ties

FIGURE 2
Thickness Measurement – Oil Carriers – Double Hull (1 July 2013)
Typical transverse section of a double hull oil carrier above 150,000 dwt
indicating longitudinal and transverse members

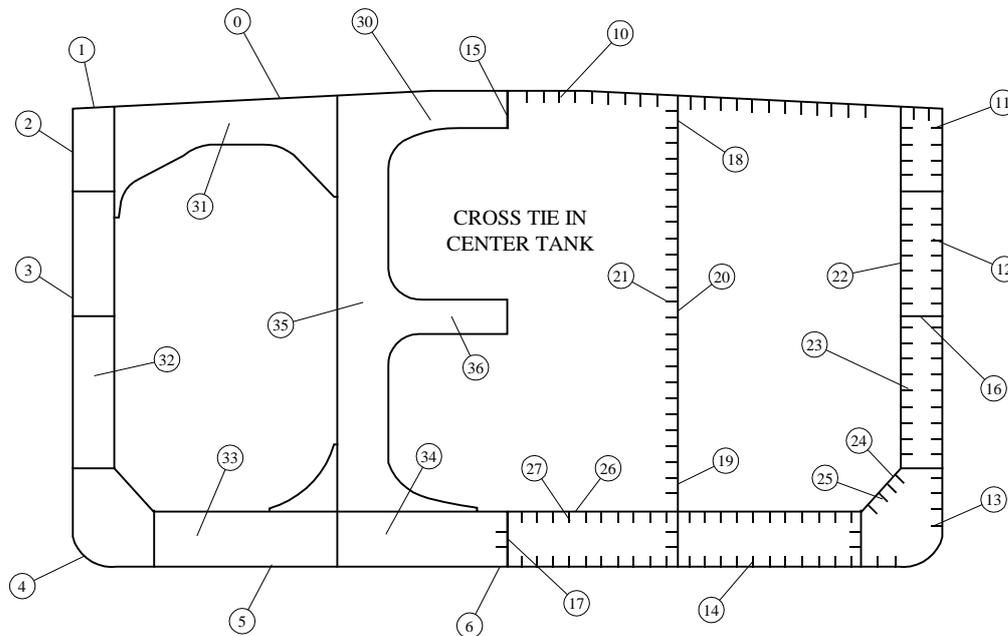

REPORT ON TM2-DHT (i) & (ii) or TM2-DHT(CSR) (i) & (ii)	
0.	Strength deck plating
1.	Stringer plate
2.	Sheerstrake
3.	Side shell plating
4.	Bilge plating
5.	Bottom shell plating
6.	Keel plate

REPORT ON TM3-DHT or TM3-DHT(CSR)	
10.	Deck longitudinals
11.	Sheerstrake longitudinals
12.	Side shell longitudinals
13.	Bilge longitudinals
14.	Bottom Longitudinals
15.	Deck girders
16.	Horizontal girders in wing ballast tanks
17.	Bottom girders
18.	Longitudinals bulkhead top strake
19.	Longitudinals bulkhead bottom strake
20.	Longitudinal bulkhead plating (remainder)
21.	Longitudinal bulkhead longitudinals
22.	Inner side plating
23.	Inner side longitudinals
24.	Hopper plating
25.	Hopper longitudinals
26.	Inner bottom plating
27.	Inner bottom longitudinals
28.	Topside tank plating
29.	Topside tank longitudinals

REPORT ON TM4-DHT or TM4-DHT(CSR)	
30.	Deck transverse center tank
31.	Deck transverse wing tank
32.	Vertical web in wing ballast tank
33.	Double bottom floor – wing tank
34.	Double bottom floor – center tank
35.	Longitudinal bulkhead vertical web
36.	Cross ties

FIGURE 3
Thickness Measurement – Oil Carriers – Double Hull (1 July 2013)

Transverse section outline to be used for longitudinal and transverse members where the diagrams in Figure 1 and Figure 2 are not suitable

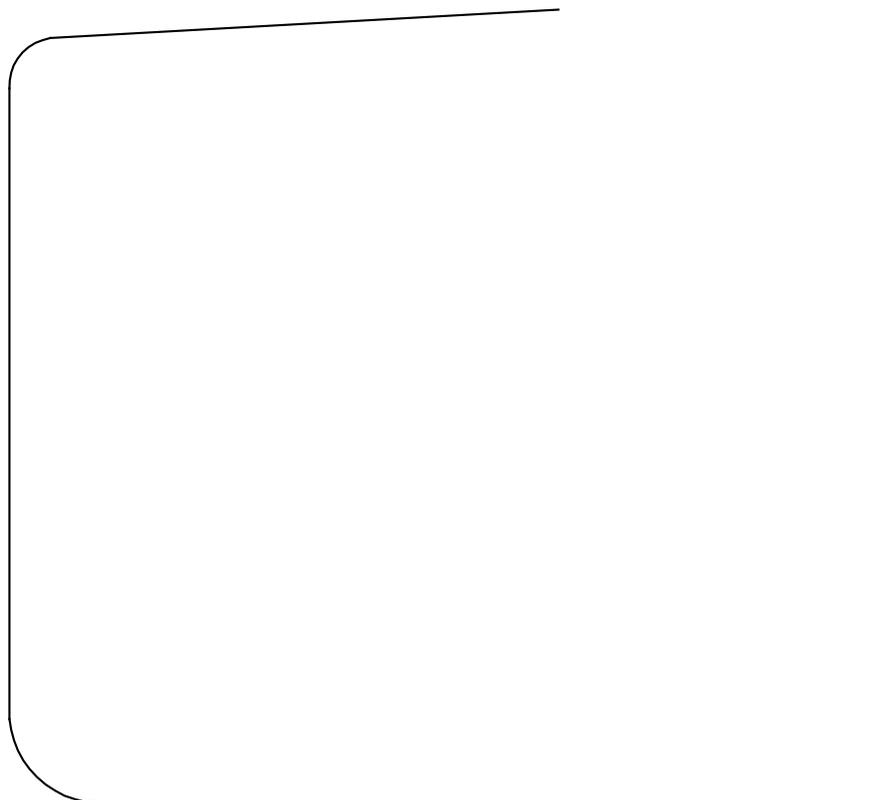

REPORT ON TM2-DHT (i) & (ii) or TM2-DHT(CSR) (i) & (ii)	REPORT ON TM3-DHT or TM3-DHT(CSR)		REPORT ON TM4-DHT or TM4-DHT(CSR)
<ul style="list-style-type: none"> 0. Strength deck plating 1. Stringer plate 2. Sheerstrake 3. Side shell plating 4. Bilge plating 5. Bottom shell plating 6. Keel plate 	<ul style="list-style-type: none"> 10. Deck longitudinals 11. Sheerstrake longitudinals 12. Side shell longitudinals 13. Bilge longitudinals 14. Bottom Longitudinals 15. Deck girders 16. Horizontal girders in wing ballast tanks 17. Bottom girders 18. Longitudinals bulkhead top strake 19. Longitudinals bulkhead bottom strake 	<ul style="list-style-type: none"> 20. Longitudinal bulkhead plating (remainder) 21. Longitudinal bulkhead longitudinals 22. Inner side plating 23. Inner side longitudinals 24. Hopper plating 25. Hopper longitudinals 26. Inner bottom plating 27. Inner bottom longitudinals 28. Topside tank plating 29. Topside tank longitudinals 	<ul style="list-style-type: none"> 30. Deck transverse center tank 31. Deck transverse wing tank 32. Vertical web in wing ballast tank 33. Double bottom floor – wing tank 34. Double bottom floor – center tank 35. Longitudinal bulkhead vertical web 36. Cross ties

FIGURE 4
Thickness Measurement – Oil Carriers – Double Hull (1 July 2013)

Areas subject to close-up survey and thickness measurements
Thickness to be reported on TM3-DHT, TM4-DHT and TM5-DHT as appropriate.

Areas (1) to (5) as defined in 7-A-13/Table 1
Thickness to be reported on TM3-DHT(CSR), TM4-DHT(CSR)
and TM5-DHT(CSR) as appropriate.

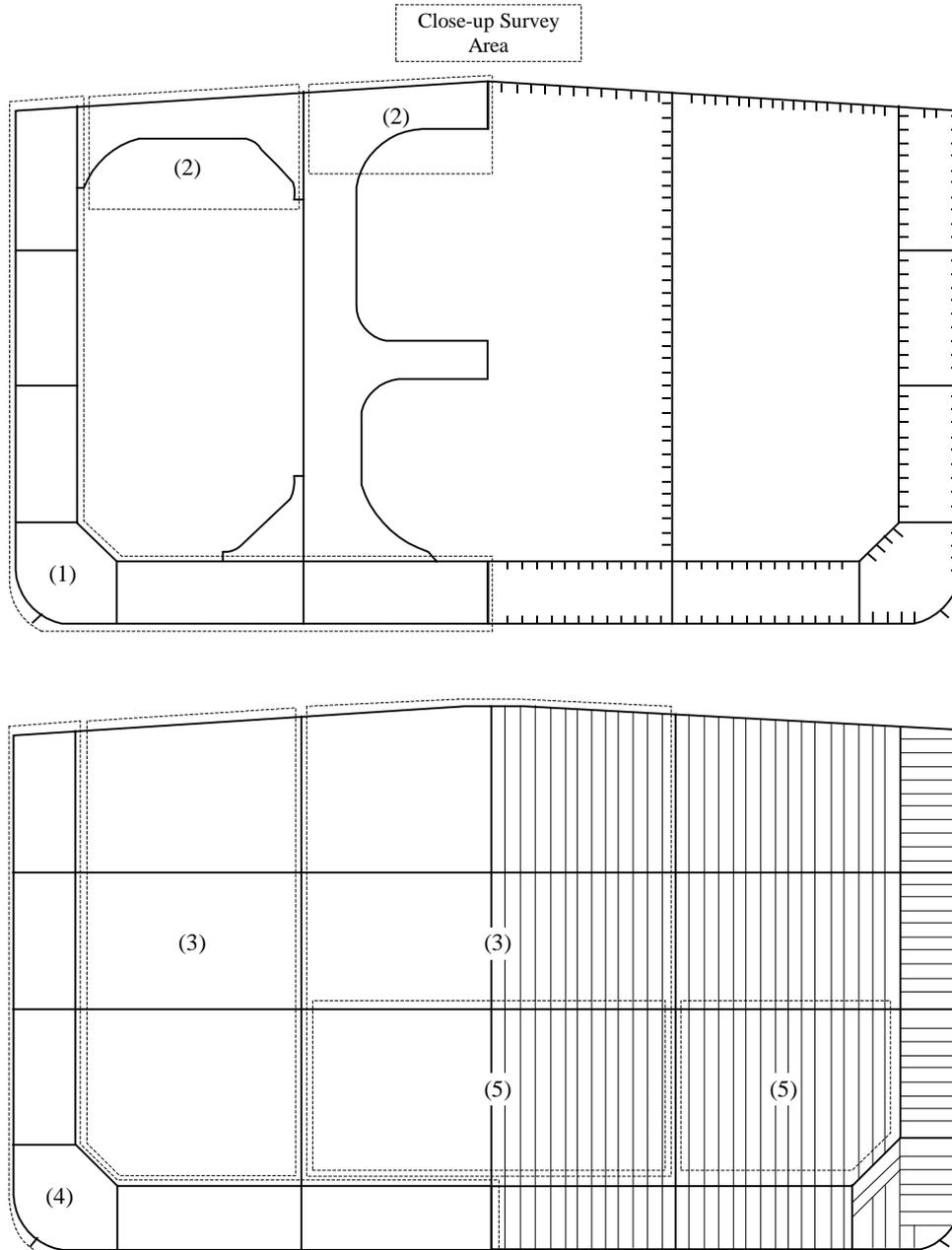

FIGURE 5
Thickness Measurement – Oil Carriers – Double Hull (1 July 2013)

Areas subject to close-up survey and thickness measurements
 Thickness to be reported on TM3-DHT and TM4-DHT as appropriate.

Areas (6) to (7) as defined in 7-A-13/Table 1
 Thickness to be reported on TM3-DHT(CSR), TM4-DHT(CSR) as appropriate.

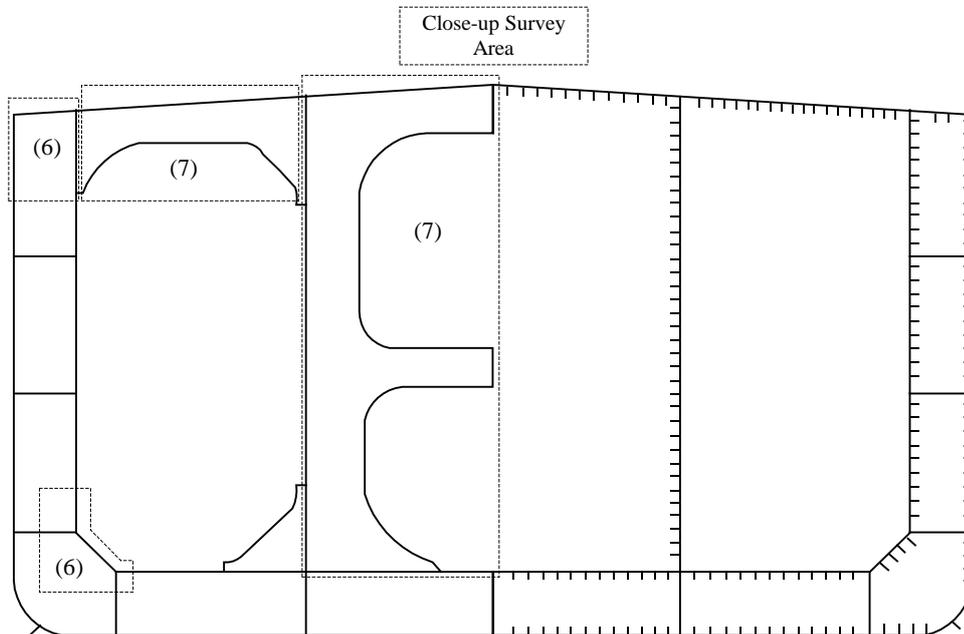

FIGURE 6
Transverse Section (1 July 2013)

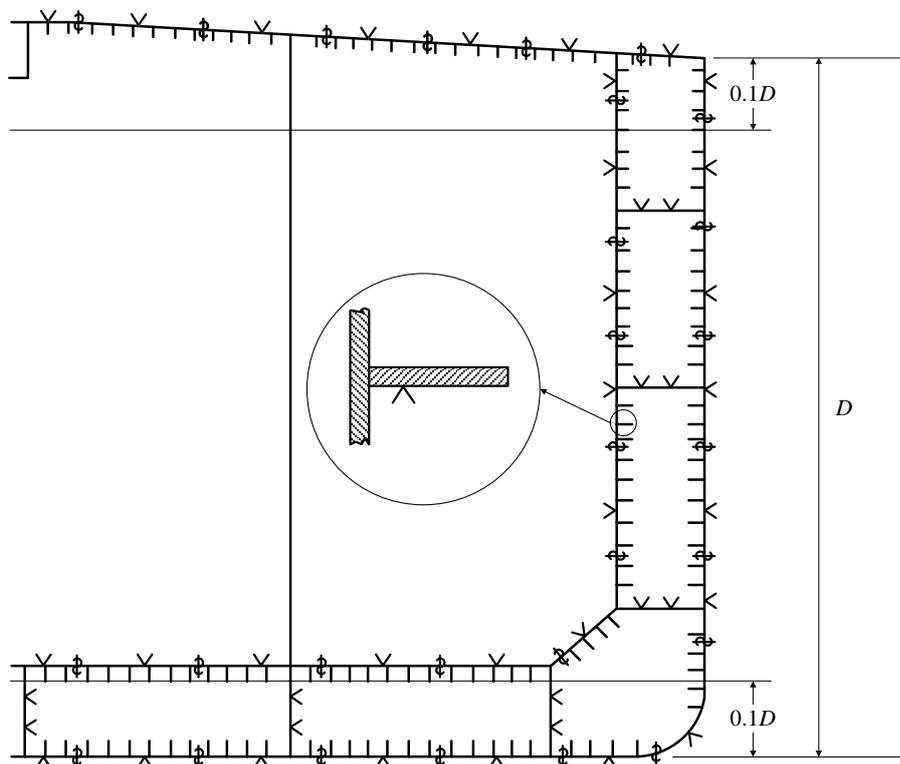

FIGURE 7
Transverse Rings in Cargo and Ballast Tanks (1 July 2013)

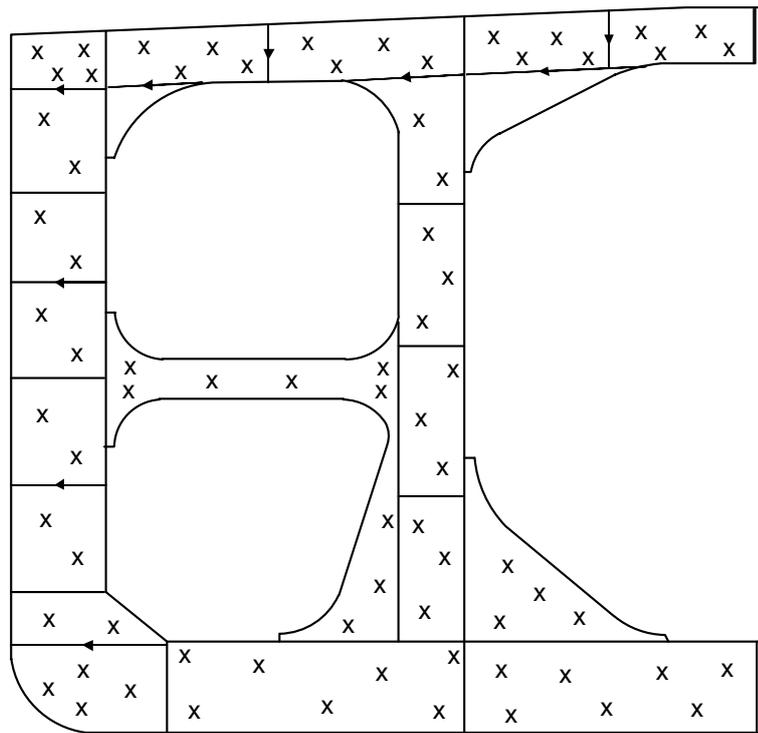

FIGURE 8
Transverse Bulkheads in Cargo Tanks (1 July 2013)

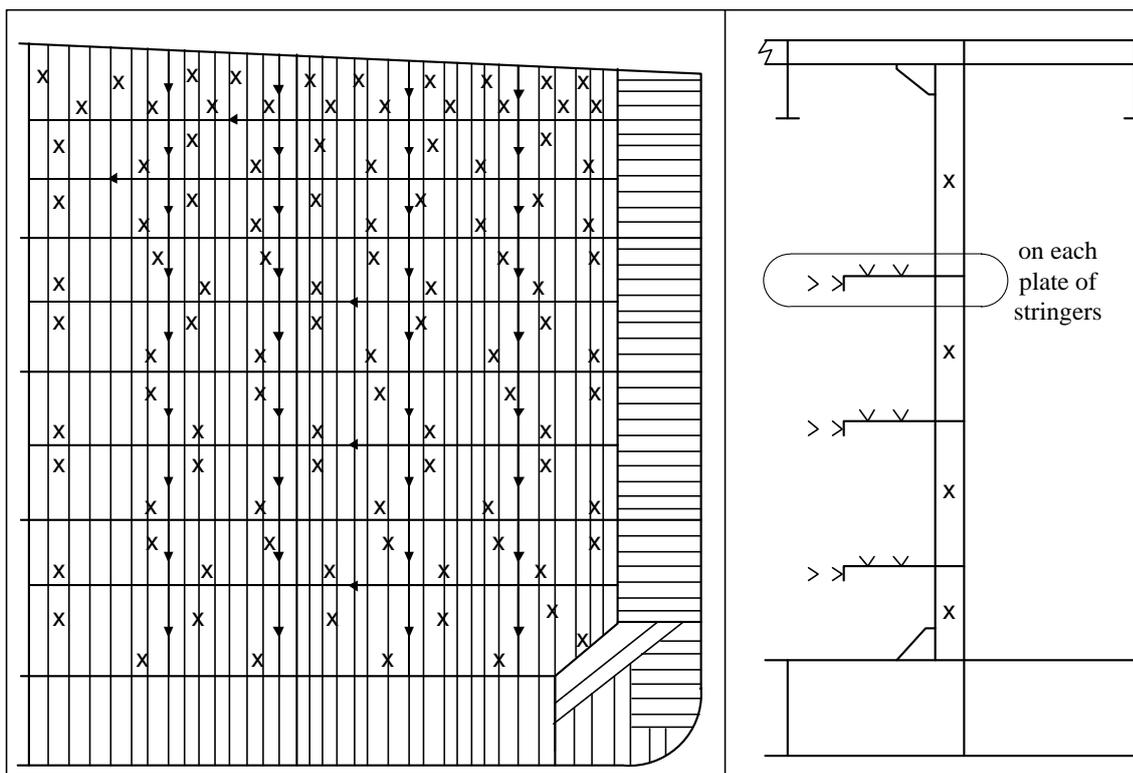

FIGURE 9
Transverse Bulkheads in Ballast Tanks (1 July 2013)

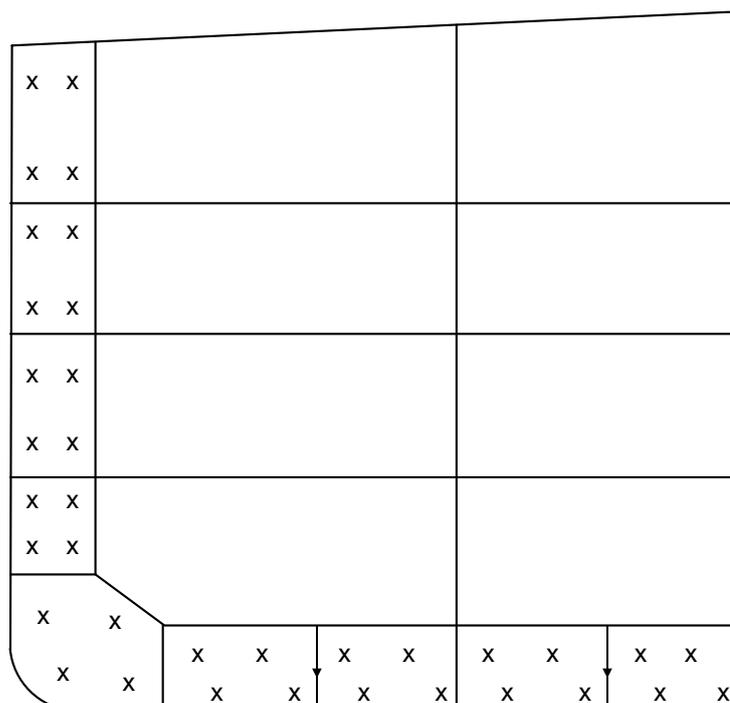

TABLE 1
Interpretations of Rule Requirements for the Locations and Number of Points to be Measured for CSR Double Hull Oil Carriers (1 July 2013)

<i>Item</i>	<i>Interpretation</i>	<i>Figure Reference</i>
Selected plates	<Selected> means at least a single point on one out of three plates, to be chosen on representative areas of average corrosion.	
Deck, bottom plates and wind-and-water strakes	At least two points on each plate to be taken either at each 1/4 extremity of plate or at representative areas of average corrosion.	
Transverse section	<p>Measurements to be taken on all longitudinal members such as plating, longitudinals and girders at the deck, side bottom, longitudinal bulkheads, inner bottom and hopper. One point to be taken on each plate. Both web and flange to be measured on longitudinals, if applicable.</p> <p>For tankers older than 10 years of age: within $0.1D$ (where D is the ship's molded depth) of the deck and bottom at each transverse section to be measured, every longitudinal and girder is to be measured on the web and face plate, and every plate is to be measured at one point between longitudinals.</p>	7-A-13/Figure 6

TABLE 1 (continued)
Interpretations of Rule Requirements for the Locations and Number of Points to be Measured for CSR Double Hull Oil Carriers (1 July 2013)

<i>Item</i>	<i>Interpretation</i>	<i>Figure Reference</i>
Transverse rings* in cargo and ballast tanks	At least two points on each plate in a staggered pattern and two points on the corresponding flange where applicable. Minimum 4 points on the first plate below deck. Additional points in way of curved parts. At least one point on each of two stiffeners between stringers/longitudinal girders.	7-A-13/Figure 7
Transverse bulkheads in cargo tanks	At least two points on each plate. Minimum 4 points on the first plate below main deck. At least one point every third stiffener to be taken each stringer. At least two points on each plate of stringers and girders, and two points on the corresponding flange. Additional points in way of curved part. Two points on each diaphragm plate of stools if fitted.	7-A-13/Figure 8
Transverse bulkheads in ballast tanks	At least 4 points on plates between stringers/longitudinal girders, or per plate if stringers/girders not fitted. At least two points on each plate of stringers and girders, and two points on the corresponding flange. Additional points in way of curved part. At least one point on two stiffeners between each stringer/longitudinal girder.	7-A-13/Figure 9
Adjacent structural members	On adjacent structural members one point per plate and one point on every third stiffener/longitudinal.	

* Note: Transverse rings means all transverse material appearing in a cross-section of the ship's hull, in way of a double bottom floor, vertical web and deck transverse (definition from CSR).

PART

7

APPENDIX

SECTION 14 Surveys Based on Preventative Maintenance Techniques (1 July 2012)

1 General

The intent of a Preventative Maintenance Program is for owners/operators to maintain their vessels with updated machinery maintenance practices, which may increase a vessel's reliability and/or operational availability. While a Surveyor may allow a reduction in the amount of covered equipment being opened for crediting towards Special Continuous Survey of Machinery (CMS), provided it is enrolled in a Preventative Maintenance Program (PMP), operational testing may be increased.

The following are procedures and conditions under which a properly conducted preventative maintenance plan may be credited as satisfying the requirements of Special Continuous Survey of Machinery. No preventative maintenance program supersedes the judgment of an ABS Surveyor, nor does it waive an ABS Surveyor(s) attendance for damage, overhaul of main engines, generator engines, steering gears, general insulation condition and resistance tests, electrical devices functional tests, reduction gear teeth examinations, hydrostatic tests of pressure vessels, tests and verification of safety devices such as relief valves, overspeed trips, emergency shut-offs, low-oil pressure trips, etc., as required by the ABS *Rules for Building and Classing Steel Vessels*, including the ABS *Rules for Survey After Construction (Part 7)*. The reference to an ABS Recognized Condition Monitoring Company refers to those companies whom ABS has identified as an External Specialist. For additional requirements, refer to 7-A-14/19 of this Appendix.

1.1 Survey and Maintenance Intervals

Maintenance is to be carried out on the basis of intervals between overhauls recommended by manufacturers, documented operator's experience and/or a condition monitoring system, where fitted. In general, the intervals for the Preventative Maintenance Program are not to exceed those specified for Special Continuous Survey of Machinery (CMS). However, for components where the maintenance is based on running hours or number of cycles, longer intervals may be accepted as long as the intervals are based on the manufacturer's recommendations. In addition, if an approved PMP is in effect, the opening of individual items of equipment may not be required during the CMS cycle, based on satisfactory results within the program.

1.2 Definitions

- i) *Special Continuous Survey of Machinery (CMS)* – A program in which the total number of survey items is arranged in order to provide for survey of approximately 20% of the machinery each year during a five-year period.
- ii) *Preventative Maintenance Program (PMP)* – A program that consists of Planned Maintenance and/or Condition Monitoring plans.
 - a) *Planned Maintenance (PM)* – A maintenance plan which uses time-based inspection, part replacement and/or overhauls in an effort to prevent equipment failures. Timing can be based on calendar days, cycles counter or equipment running hours. Such schedules are generally established by the machinery manufacturer and include lubrication servicing; filter, bearing and seal replacements; as well as major overhaul.
 - b) *Condition Monitoring (CM)* – The use of various technologies to determine the condition of equipment, at a specific moment in time, using minimal or non-invasive means. Common tools used in condition monitoring are vibration analysis, oil analysis, ferrography, thermography, electric current wave form analysis and boroscopic examination. Supplemental technologies, such as demodulation, ultrasonic analysis, shock-pulse, spike-energy, HFD, etc., for roller bearing element condition monitoring, may be used in addition to vibration analysis.

- iii) *Condition Based Maintenance (CBM)* – A maintenance plan, conducted on a frequent or real-time basis, which is based on the use of Condition Monitoring to determine when part replacement or other corrective action is required. This process involves establishing a baseline and operating parameters, then frequently monitoring the machine and comparing any changes in operating conditions to the baseline. Repairs or replacement of parts are carried out before the machinery fails based upon the use of the tools prescribed for CM.
- iv) *Reliability Centered Maintenance (RCM)* – RCM is a process that is used to determine the most effective approach to maintenance. It involves identifying actions that when taken will reduce the probability of failure and which actions are most cost effective. ABS has developed a maintenance program which uses RCM analysis of installed equipment to develop a Preventative Maintenance Program (PMP), a spare parts holdings list and includes a sustainment plan.
 - a) *Reactive Maintenance* – A RCM maintenance strategy in which equipment is run until failure before corrective action is taken. This is useful for items which are low-cost and have no impact on operational, environmental or safety concerns as a result of failure.
 - b) *One-Time Change* – A RCM maintenance strategy in which equipment or systems, that have been determined to present an unacceptable level of risk and have no potential mitigations, are replaced or significantly altered in order to provide an acceptable level of risk.

1.3 Optional Notation (2014)

An optional notation can be added to the *Record* indicating compliance with the Preventative Maintenance Program on one or more pieces of equipment. The **PMP** notation indicates less than 50%, and the **PMP+** notation indicates 50% or greater of all classed equipment is enrolled into this program.

3 Program Requirements

For a Preventative Maintenance Program to be accepted in lieu of a conventional Special Continuous Survey of Machinery, the following conditions must be met:

3.1 Age of Vessel

There is no limit on the age of a vessel when entered into the program. However, an existing vessel applying for entrance into the program will be subject to a review of the vessel's Survey Status records to ascertain the historical performance of the machinery which could affect the Preventative Maintenance Program. Provided there are no historical problems related to the maintenance of the machinery, the vessel will be considered eligible.

3.3 Surveys (2014)

Surveys related to the vessel are to be up-to-date, without outstanding recommendations which would affect the Preventative Maintenance Program. The machinery in the program is to be on a Special Continuous Survey of Machinery (CMS) cycle.

If the vessel is not on CMS, the Owner is to be advised that the vessel is to be entered in CMS. For machinery for which an outstanding recommendation exists, confirmation is to be made that repairs have been performed, or if repairs have not been performed, the Owner is to be notified that an outstanding recommendation exists.

The **PMP** notation can be applied to a vessel without an **AMS** notation with permanently installed machinery enrolled in either an approved PM, CM, or RCM plan. Vessels without an **AMS** notation will not be required to have the subject machinery on CMS, instead machinery will be credited in conjunction with the vessel's Special Periodical Survey of Hull (SSH). However, all other requirements of the **PMP** notation are to be complied with, including but not limited to the submission of an annual report to the attending Surveyor, as detailed in 7-A-14/9.3 and maintenance of the required onboard documentation, as detailed in 7-A-14/11.

Any machinery items not covered by the Preventative Maintenance Program are to be surveyed and credited in the usual way.

3.5 Damages

There is to be no record of unrepaired damage to the vessel or its machinery which would affect the vessel's ability to participate in the Preventative Maintenance Program.

3.7 Computerized Maintenance Management Systems

The activities of the Preventative Maintenance Program are to be programmed into the Computerized Maintenance Management System (CMMS) and the history of all maintenance tasks are to be recorded and stored in the CMMS by the operators/owners. These systems must include back-up devices, such as removable hard drives, thumb drives, CD-ROMs or remote on-line back-up systems and are updated at regular intervals. Details of the system are to be reviewed by the attending Surveyor during the implementation survey.

5 Program Description

5.1 General

To enroll equipment items into Planned Maintenance (PM) [See 7-A-14/13.5.1(a)], a comprehensive plan is to be submitted to the attending ABS Survey Office for review prior to conducting an implementation survey. To enroll equipment items into Condition Monitoring (CM), the documentation required by 7-A-14/15.5.1(a) is to be submitted to the responsible ABS Engineering Office for approval prior to conducting an implementation survey. Only machinery subject to Special Continuous Survey of Machinery (CMS) is to be included in the program (unless review of any non-essential machinery is specifically requested by the Owner).

5.3 Implementation Surveys

Once a plan has been reviewed/approved, an implementation survey is to be carried out by the attending Surveyor prior to program commencement. The requirements for the implementation survey are provided in 7-A-14/13.3 (for PM plans) or 7-A-14/15.3 (for CM plans).

Once this survey is carried out and the implementation found to be in order, a report confirming the implementation of the Planned Maintenance and/or Condition Monitoring plan(s) is to be submitted by the attending ABS Surveyor, and the plan(s) may be put into service.

5.5 Machinery Status Indicators

Once the Implementation Survey has been satisfactorily completed, the attending Surveyor shall advise Classification Documentation Center (CDC) that the items covered by a Planned Maintenance plan as per 7-A-14/13.5.1(a)i are to be shown by a PM indicator, and for the items covered by a Condition Monitoring plan as per 7-A-14/15.5.1(a)i are to be shown by a CM indicator. When equipment is covered by both PM and CM plans, items covered are to be shown by a PM/CM indicator. The owner is to communicate with the attending Surveyor to ensure that the Survey Manager for a vessel shows the correct indicators for all listed equipment.

5.7 Cancellation of Program

The survey arrangement for machinery under the Preventative Maintenance Program may be cancelled by ABS if the program is not being satisfactorily carried out, as a result of insufficient maintenance records, lack of knowledge by the crew of the vessel's program, the general condition of the machinery, or agreed intervals between overhauls are exceeded resulting in the annual survey not being completed within the survey window as required.

Sale, change of vessel management, change of Recognized Condition Monitoring Specialists, or transfer of class is to be cause for reconsideration of the approval. If more than one occurs, the current plan will be cancelled and a new plan will be required to be submitted for approval.

The Owner may cancel the survey arrangement for machinery under the Preventative Maintenance Program by informing ABS in writing. For this case, items which have been inspected under the program since the last Annual Survey may be credited for class at the discretion of the Surveyor.

7 Overhauls and Damage Repairs

7.1 Overhauls

For equipment enrolled in the Condition Monitoring plan, following an overhaul, new baseline data is to be recorded in the presence of an ABS Recognized Condition Monitoring Company as soon as possible, but not to exceed the next vibration signature period or six months and is to be included in the Annual Report. Documentation on overhauls of items covered by the Preventative Maintenance Program is to be reported and signed by the chief engineer.

7.3 Damage Repairs

All damage to components/machinery is to be reported to ABS. Repairs of damaged components/ machinery are to be carried out to the satisfaction of the attending Surveyor in accordance with 7-1-1/7.1 and 7-1-1/7.3.

Any repair and corrective action regarding machinery under the Preventative Maintenance Program is to be recorded and the repair verified by the attending Surveyor at the Annual Confirmation Survey. In the case of overdue outstanding recommendations or a record of unrepaired damage which would affect the Preventative Maintenance Program, the relevant items are to be removed from the program until the recommendation is fulfilled or the repair is carried out.

9 Annual Surveys and Reporting

9.1 Annual Confirmation Surveys

Simultaneously with each Annual Survey of Machinery, for vessels enrolled in a Preventative Maintenance Program, an Annual Confirmation Survey is to be performed by the attending Surveyor. The purpose of this survey is to verify that the program is being correctly operated and that the machinery has been functioning satisfactorily since the previous survey. The survey is to include the following:

- i) A general examination of the items concerned is to be carried out.
- ii) The Surveyor is to review the Owner's annual report, as detailed in 7-A-14/9.3, and the required onboard documentation as detailed in 7-A-14/11.
- iii) The performance and maintenance records are to be examined to verify that the machinery has functioned satisfactorily since the previous survey or action has been taken in response to machinery operating parameters which are outside acceptable tolerances and the overhaul intervals have been maintained.
- iv) Written details of breakdowns or malfunctions of equipment are to be made available.
- v) The description of repairs carried out is to be reviewed. Any machinery part, which has been replaced with a spare due to damage is to be retained onboard, where possible, until examined by the attending Surveyor.
- vi) At the discretion of the Surveyor, operational function tests, testing of safety devices and/or trips, confirmatory surveys and random check readings, are to be carried out as far as practicable and reasonable.

Upon satisfactory completion of the above requirements, the Preventative Maintenance Program will be accepted by ABS for its continued use. The Surveyor may credit to the current CMS cycle any of the listed items that were overhauled and tested in the presence of and to the satisfaction of the attending Surveyor. Additionally, any of the listed equipment items that have been overhauled in accordance with the Planned Maintenance schedule may be credited to the CMS by the attending Surveyor after a satisfactory operational test. Any machinery that has acceptable operating conditions as per the approved Condition Monitoring plan may be credited to the current CMS cycle by the attending Surveyor after a satisfactory operational test.

9.3 Owner's Annual Preventative Maintenance Report

The Annual Confirmation Survey of the Preventative Maintenance Program is to be carried out by the attending Surveyor. The vessel's qualified representative is to present an Annual Preventative Maintenance Report via hard copy or approved alternative electronic formats (7-A-14/9.5) containing the information detailed in 7-A-14/13.5.2 (for PM plans), 7-A-14/15.5.2 (for CM plans) and if applicable 7-A-14/17.7.2 (for RCM programs) to the attending Surveyor for review and verification at the time of the Annual Confirmation Survey of the Preventative Maintenance Program. Any reports submitted without all of the required information will be returned without action to the submitter.

If the machinery included in the Preventative Maintenance Program has changed, this is to be stated. Any machinery to be added to the program is subject to the requirements of 7-A-14/5, its respective section [7-A-14/13.5 (for PM plans) or 7-A-14/15.5 (for CM plans)] and approval by the attending Surveyor. When adding machinery to a Condition Monitoring plan, approval is required from the responsible ABS Engineering Office. When removing machinery from any Preventative Maintenance Program, CDC is to be advised and the machinery status updated accordingly.

9.5 Alternative Electronic Formats

Owners may opt to submit their annual reports to the attending Surveyor in a portable electronic format (e.g., thumb drive, CD-ROM, or e-mail attachment), for review prior to or at the time of attendance onboard, as required by 7-A-14/9. Acceptable file types are those which are compatible with MS Word, MS Excel, and/or PDF. These reports must contain all the required information. In addition, the Owners must submit, annually, in hard copy, the following to the attending Surveyor:

- i) A letter stating that the annual report is on an alternative electronic format and meets the requirements of format and file type as per 7-A-14/9.5.
- ii) A summation and results of the annual vibration signatures. (For machinery enrolled in a Condition Monitoring Plan)
- iii) A summation and analysis of all unscheduled maintenance and breakdowns of the machinery enrolled into the program.
- iv) Directions on how to retrieve the report from the alternative electronic format.

11 Onboard Documentation

The vessel's Chief Engineer shall be the responsible person onboard the vessel in charge of the Preventative Maintenance Program. If a computerized system is used for updating the maintenance documentation and maintenance program, access is to be permitted only by the Chief Engineer or other authorized persons. Additional requirements are provided in 7-A-14/13.7 (for PM plans), 7-A-14/15.7 (for CM plans) or 7-A-14/17.9 (for RCM plans).

13 Planned Maintenance (PM)

13.1 General (2016)

Owners may conduct Planned Maintenance on any item(s) of equipment. However, the following equipment cannot be enrolled into a PM plan and credit will not be given towards periodic surveys:

- System Piping (All)
- Valves (All)
- Sea Chests
- All Operational Tests
- Fire Pumps
- Fire Fighting Equipment
- Main Engine Crankpin and Crosshead bearings

- All Safety Devices, Trips and Relief Valves
- Air Receivers with associated Relief Valves and Safety Devices
- Heat Exchangers and Unfired Pressure Vessels with design pressures over 6.9 bar (7kgf/cm², 100 psi) and associated Relief Valves
- Steering Gear Piping, Pumps and Control/Relief Valves
- Steam Turbines

13.3 PM Implementation Surveys

Owners are to submit a written request to enroll their vessel(s) in the Preventative Maintenance Program. Planned Maintenance plans are to be reviewed by the attending ABS Survey Office. Both the initial review and implementation survey can be conducted at the same time onboard the vessel(s). To complete the implementation survey, the following items need to be checked:

- i)* The onboard personnel are familiar with the PM Program
- ii)* The machinery identification method and record keeping procedures are to be described.
- iii)* The Preventative Maintenance Program is to be capable of producing the documentation required for the Annual Confirmation Survey (refer to 7-A-14/9 and 7-A-14/13.5.2) and required onboard documentation is present (see 7-A-14/11 and 7-A-14/13.7).
- iv)* The vessel is to comply with the requirements of surveys and testing for retention of class.
- v)* Details and back-up capabilities of the computerized system are to be reviewed.
- vi)* Owners will submit a comprehensive schedule of servicing and overhaul including a description of the work to be performed at each interval.
 - a)* The proposed maintenance schedules are to be based upon the manufacturer recommended service and overhaul schedules. The vessel operator will submit a statement to ABS or show documentation that verifies that the proposed maintenance schedules are in accordance with manufacture recommendations.
 - b)* If the proposed maintenance schedules are based on vessel operator's previous experience due to lack of manufacturer's information, then appropriate evidence supporting operators' proposals are to be submitted for review.
- vii)* The PM Program is implemented according to the reviewed documentation and is adapted to the type and complexity of the components/systems on board.
- viii)* The Survey status for the vessel is to be reviewed by the attending Surveyor. The vessel is to be on Special Continuous Survey of Machinery (CMS). The Surveyor is to ascertain if there are any damages or open outstanding recommendations that would prevent the proposed equipment items from being allowed.
- ix)* The attending Surveyor will confirm, during the review, that the plan complies with the submission requirements of 7-A-14/13.5, including verification that machinery parts listed under 7-A-14/13 are not included. In addition, fire fighting appliances including breathing apparatus, fire extinguishers, fireman's outfits and the international shore connection cannot be included under PM.
- x)* Where the Owner's Preventative Maintenance Program includes both planned maintenance and condition monitoring, then the attending Surveyor will have to ensure that the condition monitoring details have been approved by the responsible ABS Engineering Office and comply with the requirements of 7-A-14/15.3.

13.5 Administrative Requirements

13.5.1 PM Plan Submission

13.5.1(a) For Items Covered by a Planned Maintenance Plan

- i) A list and description of the machinery.
- ii) Organization chart identifying areas of responsibility.
- iii) Schedule of servicing and overhaul. This schedule is to meet at least the servicing and overhaul intervals specified by the manufacturer and a statement to this effect is to accompany the plan.
- iv) Description of the work to be performed at each interval.
- v) Machinery identification method and record keeping procedures.
- vi) Planned maintenance sheet(s)/record(s) for each machine to be considered.
- vii) A reference list showing owner's equipment item name and ABS equivalent equipment name as shown in ABS Survey Manager.

13.5.2 Owner's Annual Preventative Maintenance Report Requirements

13.5.2(a) PM Plan Report – Annual

- i) A summary list of all machinery covered under the Planned Maintenance Program, including a complete description of work completed on each machine since the last submitted report. The Owner may add or delete equipment subject to the approval of the attending ABS Surveyor, who is also to notify the ABS Classification and Documentation Center (CDC) of any machinery additions or deletions, as necessary.
- ii) Planned maintenance sheet(s)/record(s) for each machine.
- iii) Exceptions, notes and comments noted during work.
- iv) Modifications and justifications to the schedule, such as might be recommended by a machinery manufacturer's technical bulletin.
- v) List of machines that failed prior to scheduled maintenance or servicing, and related record of corrective actions taken.

If the machinery included in the Planned Maintenance plan has changed, this is to be stated. Any machinery to be added to the plan is subject to the requirements of 7-A-14/13.5.1 and approval by the attending Surveyor.

The Owner is to advise the attending Surveyor of all machinery for which periodic maintenance is not indicated or is incomplete as per the initial planned maintenance report. In the meantime, the condition of the machinery is to be to the satisfaction of the attending Surveyor.

13.7 Onboard Documentation

13.7.1 PM Plan

- i) The latest up-to-date information required in 7-A-14/13.5.1(a)
- ii) A copy of the manufacturer's service manuals and/or shipyard's maintenance instructions
- iii) Reference documentation (trend investigation procedures, etc.)
- iv) All records showing compliance with the program (including repairs and renewals carried out) are to be made available for review by the attending Surveyor at the Annual Survey of Machinery.
- v) A copy of the reviewed PM Plan
- vi) A user's manual for the Computerized Maintenance Management System

15 Condition Monitoring (CM)

(2017) A Condition Monitoring plan, which uses quarterly, semi-annual or annual measurements, is intended to be supplemented with Planned Maintenance activities. The benefit of using condition monitoring is that it **will provide additional detail to the current condition of the equipment. This additional information can be used to support the crediting of machinery and satisfying the requirements of Special Continuous Survey of Machinery.**

With regards to vibration measurements, ABS principally allows two methods to be used towards the crediting of the CMS cycle as discussed in 7-A-14/9.1. A summary of the first method involves the Chief Engineer or other trained crewmember(s) collecting overall vibration data on a quarterly basis and a representative specialist of an ABS Recognized Condition Monitoring Company collecting one set of complete vibration signatures annually. A summary of the second method, discussed in 7-A-14/15.11, involves complete vibration signatures being collected semi-annually by a representative specialist of an ABS Recognized Condition Monitoring Company, with no requirement for data collection by the Chief Engineer or crewmembers. For both methods, one set of complete vibration signatures is required to be taken during the three months prior to the date that the Annual Preventative Maintenance Report is provided to the attending Surveyor.

When equipment is covered by both PM and CM plans (substantiated by a PM/CM indicator), the results of the CM analysis may affect the requirements of the vessel's PM plan. When the CM analysis demonstrates that the equipment is operating satisfactorily, consideration will be given for deferring appropriate PM tasks.

15.1 General (2016)

Owners may conduct Condition Monitoring on any item(s) of equipment. However, the following equipment cannot be enrolled into a CM plan and credit will not be given towards periodic surveys:

- System Piping (All)
- Valves (All)
- Sea Chests
- All Operational Tests
- Fire Fighting Equipment
- All Safety Devices, Trips and Relief Valves
- Air Receivers with associated Relief Valves and Safety Devices
- Heat Exchangers and Unfired Pressure Vessels with design pressures over 6.9 bar (7 kgf/cm², 100 psi) and associated Relief Valves

15.3 CM Implementation Surveys

Owners are to submit a written request to enroll their vessel(s) in the Preventative Maintenance Program. Condition Monitoring plans are to be approved by the responsible ABS Engineering Office. The plan must be approved before an implementation survey can be conducted. To complete the implementation survey, the following items need to be checked:

- i) The CM Program is implemented according to the approved documentation and is adapted to the type and complexity of the components/systems on board
- ii) The onboard personnel are familiar with the CM Program
- iii) The machinery identification method and record keeping procedures are to be described.
- iv) The Preventative Maintenance Program must be capable of producing the documentation required for the Annual Confirmation Survey (refer to 7-A-14/9 and 7-A-14/15.5.2) and required onboard documentation is present (7-A-14/11 and 7-A-14/15.7).
- v) Details and back-up capabilities of the computerized system are to be reviewed.
- vi) The vessel is able to comply with the requirements of surveys and testing for retention of class.
- vii) The Survey status for the vessel is to be reviewed by the attending Surveyor. The vessel is to be on Special Continuous Survey of Machinery (CMS). The Surveyor is to ascertain if there are any damages or open outstanding recommendations that would prevent the proposed equipment items from being allowed.

- viii) The attending Surveyor will confirm, during the review, that the plan complies with the submission requirements of 7-A-14/15.5, including verification that machinery parts listed under 7-A-14/15 are not included. In addition, fire fighting appliances including breathing apparatus, fire extinguishers, fireman's outfits and the international shore connection cannot be included under CM.

15.5 Administrative Requirements

15.5.1 CM Plan Submission

15.5.1(a) For Items Covered by a Condition Monitoring Plan

- i) A list and description of the machinery covered including:
 - a) Method of data collection and analysis tools
 - b) Nominal rpm
 - c) Horsepower
 - d) Location and orientation of sensor attachments, which are to be permanently marked and/or affixed by a Recognized Condition Monitoring Specialist on covered machinery
 - e) Sampling procedures for oil analysis
- ii) Organization chart identifying areas of responsibility.
- iii) Schedule of data collection.
- iv) Type and model of data collection instrument, including sensor and attachment method and calibration schedule.
- v) Acceptance criteria of data.
- vi) *Baseline data.* Initial or baseline data are to be recorded in the presence of the Surveyor and/or a representative specialist of an ABS Recognized Condition Monitoring Company and are to be compared to the acceptable vibration levels shown in SNAME's T&R Bulletin 3-42 "Guidelines for the Use of Vibration Monitoring for Preventative Maintenance" or other equivalent national or international standards. The Owner is to be notified of all machinery that does not meet acceptance criteria (i.e., machinery with high vibration levels).
- vii) A reference list showing owner's equipment item name and ABS equivalent equipment name as shown in ABS Survey Manager.

15.5.2 Owner's Annual Preventative Maintenance Report Requirements

15.5.2(a) CM Plan Report – Annual

- i) A summary report listing all machinery covered under the Condition Monitoring plan, clearly stating the overall condition of the machinery based on the most recent vibration measurement data (i.e., Satisfactory, Marginal, or Unacceptable). Data for the report must have been collected within three months of the submission date of the report by an ABS Recognized Condition Monitoring Company. This report is to be provided to the attending Surveyor.
- ii) Where the crew is taking vibration measurements, then training records for the designated crew members and description of training is to be included. Also, the type of recording device, method of data collection and calibration of the data collector must be provided. See also. The attending Surveyor may request a trained crewmember to demonstrate proficiency in vibration reading and related management of the obtained data.
- iii) Summary and analysis of machines that failed prior to a vibration reading or servicing.
- iv) Records of any maintenance conducted on equipment enrolled in the CM Plan.
- v) Records of any equipment that has been replaced, including information required by 7-A-14/15.5.1(a).

If the machinery included in the Condition Monitoring plan has changed, this is to be stated. Any machinery to be added to the plan is subject to the requirements of 7-A-14/15.5.1 approval by the responsible ABS Engineering Office and the attending Surveyor. Any machinery to be deleted from the Condition Monitoring plan is to be brought to the attention of the attending Surveyor and written documentation sent to the responsible ABS Engineering Office and CDC.

Vibration readings are to be compared to the baseline readings in the implementation report. The Owner is to advise the attending Surveyor of required maintenance or additional monitoring which is needed for machinery with vibration readings above those in the approved baseline. Machinery unavailable for measurements are to be noted and the Owner advised that readings are to be submitted for review. In the meantime, the condition of the machinery is to be to the satisfaction of the attending Surveyor.

15.7 Onboard Documentation

15.7.1 CM Plan

- i)* The latest up-to-date information required in 7-A-14/15.5.1(a).
- ii)* For vessels with onboard vibration meters or FFT vibration analyzers, manuals supplied by manufacturers for use of data collectors and computer programs, as well as guidance for machine operating and diagnosis of machine faults.
- iii)* Condition monitoring data, including all data since last opening of the machine and the original baseline data.
 - a)* Complete vibration data (including vibration signatures), as specified in 7-A-14/15.5.1(a), are to be taken and reviewed by a representative of an ABS Recognized Condition Monitoring Company on an annual basis or more frequently when warranted by abnormal conditions or operational parameters, and retained onboard for review by the attending Surveyor.
 - b)* Full trend analysis (including spectral analysis for vibration) of machinery displaying operating parameters exceeding acceptable tolerances. Also, alarm criteria.
 - c)* Relevant operational data during data recording, such as sea state, machine temperature, other equipment affecting the data, etc. are to be included.
 - d)* Quarterly overall broadband vibration meter readings recorded by vessel personnel (or documentation showing alternative techniques are approved) and retained onboard for review by the attending Surveyor.
- iv)* Reference documentation (trend investigation procedures, etc.).
- v)* Records of lube oil analysis, rotor positioning readings, and interstage bleed system pressures are to be recorded by the vessel's personnel at least on a quarterly basis and retained onboard for review annually by the attending Surveyor.
- vi)* If the vessel includes internal combustion engines in the program, the data outlined in 7-A-14/15.9.2 must be retained onboard for review annually by the attending Surveyor.
- vii)* Calibration date of equipment. Calibration is to be in accordance with the manufacturer's recommendations or annually, if not otherwise specified.
- viii)* Crew training records of the designated members, where crew is taking periodic vibration readings.
- ix)* Any repairs or changes to any machines must be reported, and a summation and analysis of all unscheduled maintenance and/or breakdowns of monitored equipment.
- x)* All records showing compliance with the program, including a copy of the most recent Owner's annual report are to be made available for review by the Surveyor at the Annual Survey of Machinery.
- xi)* A copy of the approved CM Plan and ABS approval letter
- xii)* A user's manual for the Computerized Maintenance Management System

15.9 Special Conditions

15.9.1 Steam Turbine

Condition monitoring of turbines must provide information as per 7-A-14/11.

The main propulsion turbine rotor journal bearings, thrust bearings, and flexible couplings are to be opened up for examination. The low pressure exhaust trunk is to be opened for examination of the last row of low pressure and astern wheels. Providing vibration readings, lubrication oil analysis and axial rotor position checks and turbine operating records are reviewed and all considered satisfactory by the Surveyor, the lifting of the main propulsion turbine casings (HP and LP) may be waived at alternate, subsequent Special Periodical Surveys, as outlined in 7-6-2/3.1.4.

On turbines where variable or abnormal readings are noted, readings are to be recorded by the vessel's personnel more frequently, as appropriate to properly monitor the performance range or establish the trend.

15.9.2 Internal Combustion Engines

Machine condition monitoring of internal combustion engines must provide a detailed engine analysis, as well as information provided in 7-A-14/5.1. The following data must be recorded at least monthly, unless indicated otherwise.

- i) Operating time (running hours)
- ii) Power output (MCR)
- iii) RPM
- iv) Cylinder pressure as function of crank angle
- v) Injection pressure as function of crank angle
- vi) Cylinder liner and piston ring wear (on basis of compression/firing pressures or proximity readings)
- vii) Scavenging air pressures and temperatures
- viii) Lubricating oil and cylinder oil consumption
- ix) Bearing temperatures (main, crank pin, crosshead and internal thrust, as fitted)
- x) Cylinder exhaust temperatures
- xi) Turbocharger vibration and T/C RPM
- xii) Lubricating oil analysis (quarterly)
- xiii) Crankshaft deflection readings for medium/slow speed diesel engines, as defined in 4-2-1/1.3 of the *ABS Rules for Building and Classing Steel Vessels* (quarterly).

For machines for which variable or abnormal readings are noted, readings are to be recorded by the vessel's personnel more frequently, as appropriate to properly monitor the performance range or establish the trend.

15.9.3 Electrical Switch Gear and Power Distribution Panels

Condition monitoring plans for electrical equipment are to include examination of panels, switchboards, transformers and other essential electrical apparatus by infrared photographic thermography during each five-year survey cycle while the circuit is energized and under normal workloads. A report describing the results of the survey, as well as periodic insulation resistance records must be retained onboard for review by the attending ABS Surveyor.

15.9.4 Diesel Engine Bearing Wear Monitoring Systems (2016)

Condition Monitoring plans for bearing wear monitoring systems apply to main, crosshead and crank pin bearings. The bearing wear monitoring system may be credited towards CMS under the Condition Monitoring plan, in lieu of the required bearing open out method. In order for ABS to accept this alternative to main diesel engine bearing open out inspections, the following minimum requirements have been established for implementing a bearing wear monitoring system:

- i) The bearing wear monitoring system is to be ABS Type Approved and installed as per manufacturer's recommendation.
- ii) The Owner is to provide a letter from the engine manufacturer confirming that the bearing wear monitoring system is suitable for the engine model installed, that the specified bearing monitoring system eliminates the need for normal opening of the bearings for inspections and listing the specific bearings that are covered.
- iii) Engine bearings are placed under Condition Monitoring status and an implementation survey is required.
- iv) Vessel's Chief Engineer is responsible for maintaining records of trend measurements from established initial base line value. Therefore, appropriate records are to be available for examination by the attending Surveyor during surveys.
- v) The attending Surveyor will retain the option to require (partial or full) opening of a bearing where the bearing condition analysis suggests abnormalities, based on external examination, feeler gauge readings, bearing edge condition, oil analysis results, or crank shaft deflections, etc.

For crosshead bearings enrolled in this plan, one crosshead bearing is to be opened out for inspection during each Special Survey cycle. If problems are found, then further openings may be required. Owners are encouraged to open these bearings during drydocking periods whenever possible.

15.9.5 Permanently Installed Monitoring Equipment

Permanently installed electronic analyzing equipment used for the Condition Monitoring Program is to comply with the requirements of 4-9-5/17 of the *ABS Rules for Building and Classing Steel Vessels*, regarding testing and certification of automatic and remote control systems for use onboard ship.

15.11 Alternative Techniques

Application of techniques of condition monitoring other than those mentioned above will be specially considered.

15.11.1 Semi-Annual Alternative (2014)

Condition monitoring based on semi-annual signatures is acceptable as an alternative technique for rotating machinery in lieu of quarterly overall vibration meter readings supplemented by an annual signature, as required in 7-A-14/15.7.1iii). The semi-annual signatures are to be taken and reviewed by a representative of an ABS Recognized Condition Monitoring Company. External checks, such as lube oil analysis, shaft position indicating and bearing temperatures are not affected and are to continue to be monitored by the crew at least on a quarterly basis.

The annual Owner's report is to clearly indicate that this alternative is being utilized and must include both semi-annual signatures for all of the monitored equipment. In addition, a summation and analysis of all unscheduled maintenance and/or breakdowns of the monitored equipment which were not identified by the semi-annual signatures must be included. Any reports submitted without the required statement of maintenance and/or summation will be returned without action to the submitter.

17 Reliability Centered Maintenance (RCM)

17.1 Application

The following are procedures and conditions under which a properly conducted Reliability Centered Maintenance (RCM) analysis and the resulting Preventative Maintenance Program may be credited as satisfying the requirements of Special Continuous Survey of Machinery.

No preventative maintenance plan supersedes the judgment of an ABS Surveyor, nor does it waive an ABS Surveyor(s) attendance for damage, overhaul of main engines, generator engines, steering gears, general insulation condition and resistance tests, electrical devices functional tests, reduction gear teeth examinations, hydrostatic tests of pressure vessels, tests and verification of safety devices such as relief valves, overspeed trips, emergency shut-offs, low-oil pressure trips, etc., as required by the *ABS Rules for Building and Classing Steel Vessels*, including the *ABS Rules for Survey After Construction (Part 7)*. It is a prerequisite that the machinery in this program be on a Special Continuous Survey of Machinery (CMS) cycle.

17.3 General

By using RCM principles, maintenance is evaluated and applied in a rational manner. Functional failures with the highest risk are identified and then focused on. Equipment items and their failure modes that will cause high-risk functional failures are identified for further analyses. Maintenance tasks and maintenance strategies that will reduce risk to acceptable levels are determined. Spare parts inventories are determined based on the maintenance tasks developed and a risk assessment. An RCM sustainment procedure is instituted to continually monitor and optimize maintenance. Accordingly, improved equipment and system reliability can be expected.

Additional information and explanations on how to develop a RCM program can be found in the *ABS Guide for Survey Based on Reliability Centered Maintenance (RCM Survey Guide)*, and the *ABS Guidance Notes on Reliability Centered Maintenance (RCM Guidance Notes)*.

17.3.1 Definitions

A RCM analysis as defined by the *RCM Guidance Notes* will generate additional types of maintenance tasks which are not previously defined by the Preventative Maintenance Program. In order to simplify the RCM Program plan approval process, implementation survey and annual surveys, the following groupings of these tasks will be used to determine the applicable requirements:

- i) Planned Maintenance type-tasks
 - Planned Maintenance Tasks
 - Failure Finding Tasks
 - Other Applicable and Effective Tasks
- ii) Condition Monitoring type-tasks
 - Condition Monitoring Tasks
 - Combinations of Planned Maintenance and Conditioning Monitoring Tasks

17.3.2 Optional Notations

The RCM Program is to be approved by an ABS Engineering Office. Upon completion of a satisfactory Implementation Survey, a "Certificate of Approval for Reliability Centered Maintenance Program" is to be issued by the attending Surveyor. A notation, if appropriate, will be entered in the *Record*. The Owner may select desired systems or equipment items for which a RCM analysis will be conducted and will be used to develop a Preventative Maintenance Program. All machinery items covered by the RCM analysis will be surveyed and credited in accordance with the *ABS Rules for Survey After Construction (Part 7)* and the respective section(s) of the Preventative Maintenance Program.

When the RCM Program is approved for the equipment related to:

- i) The propulsion system, including as applicable: prime mover(s), reduction gears, shafting, propeller or other thrusting device, all auxiliary systems providing, cooling, control, electrical power, exhaust, fuel, lubrication and equipment related to the steering or other directional control system, the RCM Program will be assigned and distinguished in the *Record* with the class notation **RCM (PROP)**.
- ii) The cargo handling (cargo pumps, associated piping for internal and independent tanks) and safety equipment (i.e., inert gas system, vapor emission control) for a tanker, liquefied gas carrier or chemical carrier, the RCM Program will be assigned and distinguished in the *Record* with the class notation **RCM (CARGO)**.
- iii) Systems used in connection with drilling, when the drilling system is in compliance with the *ABS Guide for the Classification of Drilling Systems*, will be distinguished in the *Record* with the class notation **RCM (CDS)**.
- iv) (2014) When the RCM Program is approved for the Production or Facilities systems and equipment on an FPSO or FSO, the RCM Program will be distinguished in the *Record* with the class notation **RCM (PFE)**.

17.3.3 Survey Credit Towards the Current CMS Cycle.

Owners may conduct a RCM analysis on any item(s) of equipment, but credit will only be given towards periodic surveys when the equipment and associated Preventative Maintenance tasks (as defined in 7-A-14/17.3.1) are in compliance with the applicable requirements stated in 7-A-14/13 and/or 7-A-14/15.

17.5 RCM Implementation Surveys

Owners are to submit a written request to enroll their vessel(s) in the Reliability Centered Maintenance (RCM) Program. RCM plans are to be approved by the responsible ABS Engineering Office. The plan must be approved before an implementation survey can be conducted. To complete the implementation survey, the following items need to be checked:

- i) The RCM Program is implemented according to the approved documentation and is adapted to the type and complexity of the components/systems on board.
- ii) The onboard personnel are familiar with the RCM Program.
- iii) The machinery identification method and record keeping procedures are described and implemented.
- iv) The onboard RCM software must be capable of producing the documentation required for the Annual Confirmation Survey (refer to 7-A-14/9 and 7-A-14/17.7.2) and required onboard documentation is present (7-A-14/11 and 7-A-14/17.9).
- v) A Spare Parts list is readily available and the crew knows how to find parts using it.
- vi) A RCM sustainment process is in effect which supports the RCM analysis and future updates.
- vii) Details and back-up capabilities of the computerized system are to be reviewed.
- viii) The vessel is able to comply with the requirements of surveys and testing for retention of class.
- ix) The Survey status for the vessel is to be reviewed by the attending Surveyor. The vessel is to be on Special Continuous Survey of Machinery (CMS). The Surveyor is to ascertain if there are any damages or open outstanding recommendations that would prevent the proposed equipment items from being allowed.
- x) The attending Surveyor will confirm, during the review, that the plan complies with the submission requirements of 7-A-14/17.7, including verification that machinery parts listed under 7-A-14/13 (or 7-A-14/15 if applicable) are not included. In addition, fire fighting appliances including breathing apparatus, fire extinguishers, fireman's outfits and the international shore connection cannot be included under RCM.
- xi) For vessels that are due to be placed in service or have recently been delivered so that little or no scheduled maintenance has been performed, the Surveyor is to verify items *i*), *iii*), *iv*), *v*), *vi*) are available and the onboard personnel have been trained to implement the RCM Program, item *ii*).

17.7 Administrative Requirements

17.7.1 Items Required for RCM Program Submission

- i) Define Systems
- ii) Identify Functions and functional failure
- iii) Conduct Failure Modes, Effects, and Criticality Analysis
- iv) Select a failure management strategy
- v) Develop a Preventative Maintenance Program plan
- vi) Develop a spare parts holding plan [refer to 7-A-14/17.7.1(a)]
- vii) Develop a RCM sustainment plan [refer to 7-A-14/17.7.1(b)]
- viii) Document and submit the analysis and plans.
- ix) A reference list showing owner's equipment item name and ABS equivalent equipment name as shown in ABS Survey Manager.

17.7.1(a) Spare Parts Holding Documentation. The spare parts holding documentation is to be a summary. The documentation is to provide the following information:

- i) There is to be identification between the maintenance task listed and the RCM analysis (e.g., Item Nos. in the RCM analysis).
- ii) The task type is to be listed (e.g., Condition Monitoring (CM), Planned Maintenance (PM), Combination of CM and PM (CM/PM), Failure Finding (FF), One-time Change (OTC), Run-to-Failure (RTF), Any Applicable and Effective Task (AAET)).
- iii) The risk due to a spare being out of stock, along with the appropriate spare parts strategy (e.g., Order parts before demand, Hold parts in storage, Revise RCM maintenance tasks, Review RCM maintenance tasks, No spares holdings required).
- iv) The maintenance procedure is listed.

An example of a Spare Parts Holding Determination summary is shown in Section 2, Table 10 of the *RCM Survey Guide*.

17.7.1(b) RCM Sustainment Documentation. The sustainment documentation is to be maintained onboard by the vessel/rig/facility operators. The sustainment process is to be designed to allow verification by the attending Surveyor at the annual Survey. Sustainment documentation is to include the following items:

- i) Trend Analysis
- ii) Maintenance Requirement Document Reviews
- iii) Task-packaging Reviews
- iv) Age-exploration Tasks
- v) Failures
- vi) Relative Ranking Analysis
- vii) Other Activities

17.7.2 Owner's Annual RCM Program Report Requirements

The Annual Confirmation of the Reliability Centered Maintenance Program will be carried out by the attending Surveyor, who will confirm the Program is being effectively implemented onboard. The vessel's Owner or qualified representative is to present an Annual Reliability Centered Maintenance Report containing the following information to the attending Surveyor for review and verification at the time of the Annual Confirmation Survey. Any reports submitted without all of the required information will be returned without action to the submitter. The annual report is to be submitted in an electronic format in accordance with the requirements of 7-A-14/9.5. Information to be included with the annual report is detailed in the following:

- i) If equipment items included in the Reliability Centered Maintenance Program are to be changed, this is to be stated. Any machinery to be added to the system will require approval by the responsible ABS Engineering Office and the attending Surveyor with appropriate notification sent to CDC. Any machinery to be deleted from the RCM Program is to be brought to the attention of the attending Surveyor and written documentation sent to the responsible ABS Engineering Office and CDC.
- ii) If during the sustainment process it was determined that the time interval for any Planned Maintenance type-task needs to be altered, then changes will need to be submitted with documentation that supports the change in interval to the attending Surveyor for review and acknowledgement.
- iii) *All Planned Maintenance type-tasks* – As per the requirements of 7-A-14/13.5.2(a)
- iv) *All Condition Monitoring type-tasks* – As per the requirements of 7-A-14/15.5.2(a)
- v) *RCM Sustainment Activities* – Evidence of sustainment activities are to be included in the annual report. The results of relative ranking analyses, trend analyses, maintenance requirements document reviews, task packaging reviews, age exploration tasks and failure investigations of all unscheduled maintenance and/or breakdowns are to be provided. Sustainment activities can be conducted ashore as long as some shipboard personnel, who have been participating in the RCM program aboard the subject vessel, are involved in the sustainment activities. Appropriate documentation can also be produced ashore but will be required to be present in addition to normally required onboard documentation during the annual confirmation survey.
- vi) *Report Exceptions* – The Owner is to advise the attending Surveyor of all machinery for which maintenance is not indicated or is incomplete as per the implementation report or when additional monitoring is needed for machinery with vibration readings above those in the approved baseline. If either of the above mentioned situations occurs, the condition of the machinery is to be to the satisfaction of the attending Surveyor.

17.9 Onboard Documentation

The vessel's Chief Engineer shall be the responsible person onboard, and in charge of the Reliability Centered Maintenance Program. If a computerized system is used for updating the maintenance documentation and maintenance program, access is to be permitted only by the Chief Engineer or other authorized persons. The following information is to be available onboard.

- i) The latest up-to-date information required in 7-A-14/15.5.1(a).
- ii) For vessels with onboard vibration meters or FFT vibration analyzers, manuals supplied by manufacturers for use of data collectors and computer programs, as well as guidance for machine operating and diagnosis of machine faults.
- iii) Condition monitoring data, including all data since last opening of the machine and the original baseline data.
- iv) Reference documentation (trend investigation procedures, etc.).
- v) Records of lube oil analysis, rotor positioning readings, and interstage bleed system pressures are to be recorded by the vessel's personnel at least on a quarterly basis and retained onboard for review annually by the attending Surveyor.
- vi) Complete vibration data, as specified in 7-A-14/15.5.1(a), are to be taken at least quarterly, or more frequently when warranted by abnormal conditions and operational parameters, and to be reviewed by a representative specialist of an ABS Recognized Condition Monitoring Company and retained onboard for review annually by the attending Surveyor.
- vii) If the vessel includes internal combustion engines in the program, the data outlined in 7-A-14/15.9.2 must be retained onboard for review annually by the attending Surveyor.
- viii) Calibration date of equipment. Calibration is to be in accordance with the manufacturer's recommendations or annually, if not otherwise specified.

- ix) Any repairs or changes to any machines must be reported, and a summation and analysis of all unscheduled maintenance and/or breakdowns of monitored equipment.
- x) All records showing compliance with the program, including a copy of the most recent Owner's annual report are to be made available for review by the Surveyor at the Annual Survey of Machinery.
- xi) Crew training records of the designated members, where crew is taking periodic vibration readings.
- xii) Records for required spare parts, inventory and ordering procedures to procure additional spare parts are to be readily available.
- xiii) Records of sustainment activities are to be readily available, refer to 7-A-14/17.7.1(b).
- xiv) A copy of the approved RCM Plan and ABS approval letter
- xv) A user's manual for the Computerized Maintenance Management System

18 Condition Based Maintenance (CBM) (2017)

Condition based maintenance (CBM), also known as predictive maintenance, attempts to evaluate the condition or health of a machine by performing periodic or continuous monitoring. This form of maintenance is the next level up from preventative maintenance. The benefit of using CBM is that it provides an owner/operator tools that do three important things: (1) determines the current health status of the equipment and (2) more importantly, can alert the operator of degraded performance and onsite failure of a machine, and (3) aids in the timing of maintenance activities. The application of such a program requires an approved CBM External Specialist to set monitoring thresholds, review the results of machine monitoring activities, and alert the operators when these thresholds are exceeded and maintenance is needed. CBM can be accomplished through remote monitoring as long as the External Specialist is able to be alerted when thresholds have been exceeded and has access to the vessel/platform's current information streams.

Condition Based Maintenance results do not remove the need to do maintenance on machinery. The results of CBM may in some cases allow for extending the intervals of maintenance and in other cases may alert the owner/operator that maintenance needs to be done earlier. When a CBM program is carried out properly, ABS will only request opening of the equipment which is enrolled in an approved CBM plan, during a Survey Cycle, when there are adverse indications or conditions.

18.1 General

Owners may conduct Condition Monitoring on any item(s) of equipment. However, the following equipment cannot be enrolled into a CBM plan and credit will not be given towards periodic surveys:

- System Piping and Valves (All)
- Sea Chests
- All Safety Devices, Relief Valves and Trips
- All Operational Tests
- Air receivers, Heat Exchangers and Unfired Pressure Vessels with a design pressure over 6.9 bar
- Fire Fighting Equipment (including breathing apparatus, fire extinguishers, fireman's outfits and the international shore connection)
- Equipment associated with corrosive or noxious substances
- Oily Water Separators
- Blowout Preventers (BOPs)
- Operational testing of equipment, automation control, monitoring, and alarm systems.

18.3 Optional Notation

An optional notation can be added to the *Record* indicating compliance with this program. The **CBM** notation indicates compliance with the **Condition Based Maintenance** on one or more pieces of equipment, A **CBM** indicator will also be placed in the Survey Manager Parts List to indicate the specific equipment enrolled in this program.

18.5 CBM Implementation Surveys

Owners are to submit a written request to enroll their vessel(s) in the Preventative Maintenance Program.

Condition Based Maintenance plans are to be approved by the responsible ABS Engineering Office. The plan must be approved before an implementation survey can be conducted. To complete the implementation survey, the following items need to be checked:

- i) The CBM plan is implemented according to the approved documentation and is adapted to the type and complexity of the components/systems on board
- ii) The onboard personnel are familiar with the CM Program
- iii) The machinery identification method and record keeping procedures are to be described.
- iv) The External Specialist and/or onboard computer system must be capable of producing the documentation required for the Annual Confirmation Survey (refer to 7-A-14/9 and 7-A-14/18.7.2) and required onboard documentation is present (7-A-14/11 and 7-A-14/18.9).
- v) Details and back-up capabilities of the computerized system are to be reviewed.
- vi) The vessel is able to comply with the requirements of surveys and testing for retention of class.
- vii) The Survey status for the vessel is to be reviewed by the attending Surveyor. The vessel is to be on Special Continuous Survey of Machinery (CMS). The Surveyor is to ascertain if there are any damages or open outstanding recommendations that would prevent the proposed equipment items from being allowed.
- viii) The attending Surveyor will confirm, during the review, that the plan complies with the submission requirements of 7-A-14/18.7, including verification that machinery parts listed under 7-A-14/18 are not included.

18.7 Administrative Requirements

18.7.1 CM Plan Submission

18.7.1(a) For Items Covered by a Condition Based Maintenance Plan

- i) A list and description of the machinery covered including:
 - a) Method of data collection and analysis tools
 - b) Nominal rpm
 - c) Horsepower
 - d) Location and orientation of sensor attachments, which are to be permanently marked and/or affixed by a Recognized Condition Monitoring Specialist on covered machinery
 - e) Sampling procedures for oil analysis
- ii) Organization chart identifying the CBM plan areas of responsibility.
- iii) Schedule of data collection.
- iv) Type and model of data collection instrument(s), including sensor and attachment method and calibration schedule. Permanently installed equipment onboard the vessel/platform must demonstrate suitability for onboard marine as per 7-A-14/18.11.5.
- v) Acceptance criteria of data.

- vi) *Baseline data.* Initial or baseline data are to be recorded an ABS Recognized Condition Monitoring Company and are to be compared to the acceptable vibration levels shown in SNAME's T&R Bulletin 3-42 "Guidelines for the Use of Vibration Monitoring for Preventative Maintenance" or other equivalent national or international standards. The Owner is to be notified of all machinery that does not meet acceptance criteria (i.e., machinery with high vibration levels).
- vii) A reference list showing owner's equipment item name and ABS equivalent equipment name as shown in ABS Survey Manager.
- ix) Owner/Operator acknowledgement that they will follow the installed CBM computerized system alerts or Recognized Specialist maintenance recommendations upon receipt and that the owner will be maintaining the specified equipment based on CBM results rather than the manufacturer's recommended maintenance schedule. While CBM will normally alert the user to issues, there is still a potential for the equipment to fail prior to user intervention.

18.7.2 Owner's Annual Predictive Maintenance Report Requirements

18.7.2(a) CBM Plan Report – Annual

- i) A summary report listing all machinery covered under the Condition Based Maintenance plan, clearly stating the overall condition of the machinery based on the most recent vibration measurement data (i.e., Satisfactory, Marginal, or Unacceptable). Data for the report must have been analyzed by an ABS Recognized Condition Monitoring Company. This report is to be provided to the attending Surveyor and should be verified against the information shown onboard the vessel.
- ii) Summary of maintenance actions recommended by the Recognized Specialist.
- iii) Records of any maintenance conducted on equipment enrolled in the CBM Plan.
- iv) Records of any equipment that has been replaced, including information required by 7-A-14/18.7.1(a).

If the machinery included in the Condition Based Maintenance plan has changed, this is to be stated. Any machinery to be added to the plan is subject to the requirements of 7-A-14/18.7.1 and approval by the responsible ABS Engineering Office and the attending Surveyor. Any machinery to be deleted from the Condition Based Maintenance plan is to be brought to the attention of the attending Surveyor and written documentation sent to CDC.

If any equipment is unable to be monitored for extended periods, due to connectivity or sensor issues, the Owner is to advise the Responsible Survey office and any attending Surveyor immediately. Until CBM equipment monitoring is resumed, the condition of the machinery is to be to the satisfaction of the attending Surveyor applying the principles of a CM plan (as per 7-A-14/15).

18.9 Onboard Documentation

18.9.1 CBM Plan

- i) The latest up-to-date information required in 7-A-14/18.7.1(a).
- ii) For vessels with onboard vibration meters or FFT vibration analyzers, manuals supplied by manufacturers for use of data collectors and computer programs, as well as guidance for machine operating and diagnosis of machine faults.
- iii) Condition monitoring data, including all data since last opening of the machine and the original baseline data.
- iv) Full trend analysis (including spectral analysis for vibration) of machinery displaying operating parameters exceeding acceptable tolerances. Also, alarm criteria.
- v) Reference documentation (trend investigation procedures, etc.).

- vi)* Records of lube oil analysis, rotor positioning readings, and interstage bleed system pressures are to be recorded by the vessel's personnel at least on a quarterly basis and retained onboard for review annually by the attending Surveyor.
- vii)* If the vessel includes internal combustion engines in the program, the data outlined in 7-A-14/15.9.2 must be retained onboard for review annually by the attending Surveyor.
- viii)* Calibration date of equipment. Calibration is to be in accordance with the manufacturer's recommendations or annually, if not otherwise specified.
- ix)* Any repairs or changes to any machines must be reported, and a summation and analysis of all unscheduled maintenance of monitored equipment.
- x)* All records showing compliance with the program, including a copy of the most recent Owner's annual report are to be made available for review by the Surveyor at the Annual Survey of Machinery.
- xi)* A copy of the approved CBM Plan and ABS approval letter
- xii)* A user's manual for the Computerized Maintenance Management System

18.11 Acceptable Groupings of Condition Monitoring Techniques

For critical equipment, Condition Based Maintenance is normally accomplished through the use of multiple Condition Monitoring techniques. The intent of using multiple Condition Monitoring techniques is to provide detection and prediction of the failure modes associated with that piece of equipment. The subsections below are used to define the minimum acceptable grouping of techniques for specific types of critical equipment. When the minimum acceptable grouping of techniques is outside the owner/operator's scope of maintenance efforts, doesn't cover all the failure modes for a specific model or is not defined, it is incumbent upon the owner to propose a satisfactory grouping of techniques as described in 7-A-14/18.11.4

18.11.1 Turbine (Gas or Steam)

- i)* Vibration
- ii)* Performance data
- iii)* Lube Oil analysis (monthly minimum)

18.11.2 Internal Combustion Engines

- i)* Vibration
- ii)* Performance data
- iii)* Lube Oil analysis (monthly minimum)
- iv)* Bearing Wear systems

18.11.3 Propulsion or Position Keeping Thrusters

- i)* Vibration
- ii)* Performance data
- iii)* Lube Oil analysis (monthly minimum)
- iv)* Water in Lube Oil sensors (for all Lube Oil Systems in contact with external water seals)
- v)* Company procedure for replacing failed thruster at-sea.

18.11.4 For all other Equipment

For all other equipment not mentioned above and for an alternate application of techniques other than those mentioned within 7-A-14/18.11.1 through 7-A-14/18.11.3, the following will need to be submitted:

- i)* Owner is to identify Failure Causes and/or Modes that are addressed by each task.
- ii)* Identify monitoring technique(s) to cover the applicable Failure Mode(s)

iii) Provide basis for monitoring intervals

- a) Intervals may be real-time or periodic. If selecting a periodic basis it is to be less than one-half of the Potential Failure (PF) interval. PF interval is defined as the time between when the equipment deteriorates to the point to which it can be detected (P) and when the failure is not mitigated, the point at which a "hard" failure or shutdown occurs (F).

18.11.5 Permanently Installed Monitoring Equipment

Permanently installed electronic analyzing equipment used for Condition Monitoring is to comply with the requirements of 4-9-3/17 of the ABS *Rules for Building and Classing Steel Vessels*, regarding testing and certification of automatic and remote control systems for use onboard ship.

18.11.6 External Specialist Certification

External Specialist, also referred to as a Recognized Specialist, are required to be certified by ABS for each specific technique to be used. External Specialists requesting to be certified in CBM will need to demonstrate that they have experience in predictive analysis and are able to pre-emptively identify failures in a manner which would allow an operator to act before the failure(s) occur.

19 Information

For information on becoming an ABS External Specialist, please contact:

American Bureau of Shipping
16855 Northchase Drive
Houston, TX 77060-6008

Attn: External Specialist Coordinator

Telephone: 281-877-5971

Fax: 281-877-6012

21 ABS Offices Responsible for PMP and RCM

ABS Americas

ABS Americas Division
16855 Northchase Drive
Houston, TX 77060-6008

Attn: Manager, Houston SED – Ship Machinery & Systems

ABS Europe

ABS Europe Ltd.
No. 1 Frying Pan Alley
London, E1 7HR, United Kingdom

Attn: Manager, Engineering

ABS Pacific

ABS Pacific Division
Urban Square Yokohama
4th/9th Floor
1-1 Sakae-Cho
Kanagawa-Ku
Yokohama 221-0052, Japan

Attn: Manager, Engineering Services, Machinery, Electrical & Control Systems

ABS Greater China
ABS Greater China Division
5th Floor
Silver Tower
No. 85 Taoyuan Road
Luwan District
Shanghai, 200021 P.R. China

Attn: Manager, Engineering Services

PART

7

APPENDIX

SECTION 15 Report on Thickness Measurement of Bulk Carriers – Double Skin (CSR and Non-CSR Vessels) (1 July 2013)

1 Instructions

1.1 Non-CSR Vessels

1.1.1

This document is to be used for recording thickness measurements as required by the Enhanced Survey Program (see 7-3-2/5.19.5).

1.1.2

Reporting forms TM1-DSBC, TM2-DSBC(i), TM2-DSBC(ii), TM3-DSBC, TM4-DSBC, TM5-DSBC and TM6-DSBC are to be used for recording thickness measurements.

1.1.3

The maximum allowable diminution could be stated in an attached document.

1.1.4

7-A-15/Figures 1–3 are guidance diagrams and notes relating to the reporting forms and the procedure for thickness measurement on Double Skin Bulk Carriers.

1.1.5

7-A-15/Figures 4–6 are guidance diagrams and notes relating to the reporting forms and the procedure for thickness measurement on Double Skin Bulk Carriers.

1.3 CSR Vessels

1.3.1

This document is to be used for recording thickness measurements of double skin bulk carriers built under IACS Common Structural Rules (CSR) as required by the IACS unified Requirement Z10.5.

1.3.2

Reporting forms TM1-DSBC(CSR), TM2-DSBC(CSR) (i) and (ii), TM3-DSBC(CSR), TM4-DSBC(CSR), TM5-DSBC(CSR) and TM6-DSBC(CSR) are to be used for recording thickness measurements.

1.3.3

The as-built thickness and voluntary thickness addition and renewal thickness (minimum allowable thickness) are to be stated in the said forms.

1.3.4

7-A-15/Figures 1 through 3 and 5 are guidance diagrams and notes relating to the reporting forms and the IACS unified Requirements for thickness measurement.

1.3.5

7-A-15/Figures 7 through 12 and 7-A-5/Table 1 are guidance diagrams and notes relating to the rule requirements for the locations and number of points to be measured for CSR double skin bulk carriers.

1.5 Reporting Forms

The reporting forms should, where applicable, be supplemented by data presented on structural sketches.

General Particulars

Ships name:-

IMO number

ABS identification number

Port of registry:-

Gross tons:-

Deadweight:-

Date of build:-

Classification society:-

Name of Company performing thickness measurement:-

Thickness measurement company certified by:-

Certificate No.

Certificate valid from _____ to _____

Place of measurement

First date of measurement:-

Last date of measurement:-

Special Periodical Survey/Intermediate Survey due:-*

Details of measurement equipment:-

Qualification of operator:-

Report Number:- _____ consisting of _____ Sheets

Name of operator:- _____ Name of surveyor:- _____

Signature of operator:- _____ Signature of surveyor:- _____

Company official stamp:- _____ Classification Society Official Stamp:- _____

*Delete as appropriate.

TM1-DSBC(1 July 2006)

Report on THICKNESS MEASUREMENT of ALL DECK PLATING, ALL BOTTOM SHELL PLATING or SIDE SHELL PLATING*
 (* delete as appropriate)

Ship's Name _____ Class Identity No. _____ Report No. _____

STRAKE POSITION	PLATE POSITION	No. or Letter	Org thk mm	Forward Reading						Aft Reading						Mean Diminution %		Max. Alwb. Dim. mm
				Gauged		Diminution P		Diminution S		Gauged		Diminution P		Diminution S		P	S	
				P	S	mm	%	mm	%	P	S	mm	%	mm	%			
12th forward																		
11th																		
10th																		
9th																		
8th																		
7th																		
6th																		
5th																		
4th																		
3rd																		
2nd																		
1st																		
Amidships																		
1st aft																		
2nd																		
3rd																		
4th																		
5th																		
6th																		
7th																		
8th																		
9th																		
10th																		
11th																		
12th																		

Operators Signature _____

NOTES - See Reverse

NOTES

1. This report is to be used for recording the thickness measurement of:
 - 1.1 All strength deck plating within the cargo area.
 - 1.2 All keel, bottom shell plating and bilge plating within the cargo area.
 - 1.3 Side shell plating, including selected wind and water strakes outside the cargo area.
 - 1.4 All wind and water strakes within the cargo area.
2. The strake position is to be clearly indicated as follows:
 - 2.1 For strength deck, indicate the number of the strake of plating inboard from the stringer plate.
 - 2.2 For bottom plating, indicate the number of the strake of plating outboard from the keel plate.
 - 2.3 For side shell plating, give number of the strake of plating below sheerstrake and letter as shown on shell expansion.
3. Only the deck plating strakes outside line of openings are to be recorded.
4. Measurements are to be taken at the forward and aft areas of all plates, and where plates cross ballast/cargo tank boundaries, separate measurements for the area of plating in way of each type of tank are to be recorded.
5. The single measurements recorded are to represent the average of multiple measurements.
6. The maximum allowable diminution could be stated in an attached document.

TM2-DSBC(i) (1 July 2006)

Report on THICKNESS MEASUREMENT OF SHELL AND DECK PLATING (one, two or three transverse sections)

Ship's Name _____ Class Identity No. _____ Report No. _____

STRENGTH DECK AND SHEERSTRAKE PLATING																																							
STRAKE POSITION	FIRST TRANSVERSE SECTION AT FRAME NUMBER								SECOND TRANSVERSE SECTION AT FRAME NUMBER								THIRD TRANSVERSE SECTION AT FRAME NUMBER																						
	No. or Ltr	Org Thk mm	Max Alwb Dim. mm	Gauged		Diminution P		Diminution S		No. or Ltr	Org Thk mm	Max Alwb Dim. mm	Gauged		Diminution P		Diminution S		No. or Ltr	Org Thk mm	Max Alwb Dim. mm	Gauged		Diminution P		Diminution S													
				P	S	mm	%	mm	%				P	S	mm	%	mm	%				P	S	mm	%	mm	%												
Stringer Plate																																							
1st strake Inboard																																							
2nd																																							
3rd																																							
4th																																							
5th																																							
6th																																							
7th																																							
8th																																							
9th																																							
10th																																							
11th																																							
12th																																							
13th																																							
14th																																							
centre strake																																							
sheer strake																																							
TOPSIDE TOTAL																																							

Operators Signature _____

NOTES - See Reverse

NOTES

1. This report is to be used for recording the thickness measurement of:
Strength deck plating and sheerstrake plating transverse sections:
Two or three sections within the cargo area, comprising the structural items (0), (1) and (2), as shown on the diagram of typical transverse section (See 7-A-15/Figures 3, 4 and 5).
2. Only the deck plating strakes outside the line of openings are to be recorded.
3. The topside area comprises deck plating, stringer plate and sheerstrake (including rounded gunwales).
4. The exact frame station of measurement is to be stated.
5. The single measurements recorded are to represent the average of multiple measurements.
6. The maximum allowable diminution could be stated in an attached document.

TM2-DSBC(ii) (1 July 2006)

Report on THICKNESS MEASUREMENT OF SHELL AND DECK PLATING (one, two or three transverse sections)

Ship's Name _____ Class Identity No. _____ Report No. _____

SHELL PLATING																											
STRAKE POSITION	FIRST TRANSVERSE SECTION AT FRAME NUMBER								SECOND TRANSVERSE SECTION AT FRAME NUMBER								THIRD TRANSVERSE SECTION AT FRAME NUMBER										
	No. or Ltr	Org Thk mm	Max Alwb Dim. mm	Gauged		Diminution P		Diminution S		No. or Ltr	Org Thk mm	Max Alwb Dim. mm	Gauged		Diminution P		Diminution S		No. or Ltr	Org Thk mm	Max Alwb Dim. mm	Gauged		Diminution P		Diminution S	
				P	S	mm	%	mm	%				P	S	mm	%	mm	%				P	S	mm	%	mm	%
1st below sheer strake																											
2nd																											
3rd																											
4th																											
5th																											
6th																											
7th																											
8th																											
9th																											
10th																											
11th																											
12th																											
13th																											
14th																											
15th																											
16th																											
17th																											
18th																											
19th																											
20th																											
keel strake																											
BOTTOM TOTAL																											

Operators Signature _____

NOTES - See Reverse

NOTES

1. This report is to be used for recording the thickness measurement of:
Shell plating transverse sections:
One, two or three sections within the cargo area comprising the structural items (3), (4), (5) and (6), as shown on the diagram of typical transverse section (See 7-A-15/Figures 3, 4 and 5).
2. The bottom area comprises keel, bottom and bilge plating.
3. The exact frame station of measurement is to be stated.
4. The single measurements recorded are to represent the average of multiple measurements.
5. The maximum allowable diminution could be stated in an attached document.

TM3-DSBC(1 July 2006)

Report on THICKNESS MEASUREMENT OF LONGITUDINAL MEMBERS (one, two or three transverse sections)

Ship's Name _____ Class Identity No. _____ Report No. _____

STRUCTURAL MEMBER	FIRST TRANSVERSE SECTION AT FRAME NUMBER								SECOND TRANSVERSE SECTION AT FRAME NUMBER								THIRD TRANSVERSE SECTION AT FRAME NUMBER										
	Item No.	Org Thk	Max Alwb Dim.	Gauged		Diminution P		Diminution S		Item No.	Org Thk	Max Alwb Dim.	Gauged		Diminution P		Diminution S		Item No.	Org Thk	Max Alwb Dim.	Gauged		Diminution P		Diminution S	
				P	S	mm	%	mm	%				P	S	mm	%	mm	%				P	S	mm	%	mm	%
		mm	mm								mm	mm										mm	mm				

Operators Signature _____

NOTES - See Reverse

NOTES

1. This report is to be used for recording the thickness measurement of:
Longitudinal Members at transverse sections:
Two or three sections within the cargo area, comprising the structural items (10) to (25), as shown on the diagram of typical transverse section (See 7-A-15/Figures 3, 4 and 5).
2. The exact frame station of measurement is to be stated.
3. The single measurements recorded are to represent the average of multiple measurements.
4. The maximum allowable diminution could be stated in an attached document.

TM4-DSBC (1 July 2006)

Report on THICKNESS MEASUREMENT OF TRANSVERSE STRUCTURAL MEMBERS
In the double bottom, hopper side and topside water ballast tanks

Ship's Name _____ Class Identity No. _____ Report No. _____

TANK DESCRIPTION :									
LOCATION OF STRUCTURE :									
STRUCTURAL MEMBER	ITEM	Original Thickness mm	Maximum Allowable Diminution mm	Gauged		Diminution P		Diminution S	
				Port	Starboard	mm	%	mm	%

Operators Signature _____

NOTES - See Reverse

NOTES

1. This report is to be used for recording the thickness measurement of transverse structural members, comprising the appropriate structural items (30) to (34), as shown on diagram of typical transverse section (See 7-A-15/Figures 3, 4 and 5).
2. Guidance for areas of measurement is indicated on the diagrams shown on 7-A-15/Figure 6.
3. The single measurements recorded are to represent the average of multiple measurements.
4. The maximum allowable diminution could be stated in an attached document.

TM5-DSBC (1 July 2006)

Report on THICKNESS OF WATERTIGHT TRANSVERSE BULKHEADS IN CARGO HOLDS

Ship's Name _____ Class Identity No. _____ Report No. _____

LOCATION OF STRUCTURE :	FRAME NO. :							
STRUCTURAL COMPONENT (PLATING/STIFFENER)	Original Thickness mm	Maximum Allowable Diminution mm	Gauged		Diminution P		Diminution S	
			Port	Starbd	mm	%	mm	%

Operators Signature _____

NOTES - See Reverse

NOTES

1. This report form is to be used for recording the thickness measurement of watertight transverse bulkheads in cargo holds.
2. Guidance for areas of measurement is indicated on the diagrams shown on 7-A-15/Figure 6.
3. The single measurements recorded are to represent the average of multiple measurements.
4. The maximum allowable diminution could be stated in an attached document.

TM6-DSBC(1 July 2006)

Report on THICKNESS MEASUREMENT OF MISCELLANEOUS STRUCTURAL MEMBERS

Ship's Name _____

Class Identity No. _____

Report No. _____

STRUCTURAL MEMBER :							SKETCH		
LOCATION OF STRUCTURE :									
Description	Org Thk. mm	Maximum Allowable Diminution mm	Gauged		Diminution P		Diminution S		
			P	S	mm	%	mm	%	

Operators Signature _____

NOTES - See Reverse

NOTES

1. This report form is to be used for recording the thickness measurement of miscellaneous structural members, including the structural items (40), (41) and (42), as shown on diagram of typical transverse section (See 7-A-15/Figure 3, 4 and 5).
2. Guidance for areas of measurement is indicated on the diagrams shown on 7-A-15/Figure 6.
3. The single measurements recorded are to represent the average of multiple measurements.
4. The maximum allowable diminution could be stated in an attached document.

TM1-DSBC(CSR) (1 July 2013)

Report on THICKNESS MEASUREMENT of ALL DECK PLATING, ALL BOTTOM PLATING or SIDE SHELL PLATING*
 (* delete as appropriate)

Ship's Name _____ Class Identity No. _____ Report No. _____

STRAKE POSITION	PLATE POSITION	No. or Letter	As Built Thk. mm	Voluntary Thickness Addition mm	Renewal Thickness mm (a)	Forward Reading				Aft Reading				Mean Remaining Corr. Addition, mm [(c1) + (c2)]/2			
						Gauged Thk. mm (b1)		Remaining Corr. Addition, mm (c1) = (b1) - (a)		Gauged Thk. mm (b1)		Remaining Corr. Addition, mm (c1) = (b1) - (a)		P	S		
						P	S	P	S	P	S	P	S	P	S		
12th forward																	
11th																	
10th																	
9th																	
8th																	
7th																	
6th																	
5th																	
4th																	
3rd																	
2nd																	
1st																	
Amidships																	
1st aft																	
2nd																	
3rd																	
4th																	
5th																	
6th																	
7th																	
8th																	
9th																	
10th																	
11th																	
12th																	

Operators Signature _____

NOTES - See Reverse

NOTES TO REPORT TM1-DSBC(CSR)

1. This report is to be used for recording the thickness measurement of:
 - 1.1 All strength deck plating within cargo length area.
 - 1.2 All keel, bottom shell plating and bilge plating within the cargo length area.
 - 1.3 Side shell plating including selected wind and water strakes outside the cargo length area.
 - 1.4 All wind and water strakes within the cargo length area.
2. The strake position is to be clearly indicated as follows:-
 - 2.1 For strength deck indicate the number of the strake of plating inboard from the stringer plate.
 - 2.2 For bottom plating indicate the number of the strake of plating outboard from the keel plate.
 - 2.3 For side shell plating give number of the strake of plating sheerstrake and letter as shown on shell expansion.
3. Only the deck plating strakes outside line of openings are to be recorded.
4. Measurements are to be taken at the forward and aft areas of all plates and the single measurements recorded are to represent the average of multiple measurements.
5. The remaining corrosion addition is to be recorded with result of gauged thickness minus renewal thickness. If the result is negative, the structure in way shall be renewed, and the mark “R” is to be indicated in the right-hand column. If the result is between 0 and 0.5 mm (0 included), the structure in way shall be additional gauged, and the mark “S” is to be indicated in the right-hand column.

NOTES TO REPORT TM2-DSBC(CSR) (i)

1. This report is to be used for recording the thickness measurement of:
Strength deck plating and sheerstrake plating transverse sections:
One, two or three sections within the cargo length area, comprising of the structural items (1), (2) and (3) as shown on the diagram of typical transverse section, 7-A-15/Figures 3 and 5.
2. Only the deck plating strakes outside the line of openings are to be recorded.
3. The topside area comprises deck plating, stringer plate and sheerstrake (including rounded gunwales).
4. The exact frame station of measurement is to be stated.
5. The single measurements recorded are to represent the average of multiple measurements.
6. The remaining corrosion addition is to be recorded with result of gauged thickness minus renewal thickness. If the result is negative, the structure in way shall be renewed, and the mark “R” is to be indicated in the right-hand column. If the result is between 0 and 0.5 mm (0 included), the structure in way shall be additional gauged, and the mark “S” is to be indicated in the right-hand column.

NOTES TO REPORT TM2-DSBC(CSR) (ii)

1. This report is to be used for recording the thickness measurement of:
Shell plating transverse sections:
One, two or three sections within cargo length area comprising of the structural items (4), (5), (6) and (7) as shown on the diagram of typical transverse section, 7-A-15/Figures 3 and 5.
2. The bottom area comprises keel, bottom and bilge plating.
3. The exact frame station of measurement is to be stated.
4. The single measurements recorded are to represent the average of multiple measurements.
5. The remaining corrosion addition is to be recorded with result of gauged thickness minus renewal thickness. If the result is negative, the structure in way shall be renewed, and the mark “R” is to be indicated in the right-hand column. If the result is between 0 and 0.5 mm (0 included), the structure in way shall be additional gauged, and the mark “S” is to be indicated in the right-hand column.

NOTES TO REPORT TM3-DSBC(CSR)

1. This report is to be used for recording the thickness measurement of:
Longitudinal Members at transverse sections:
One, two, or three sections within the cargo length area, comprising of the appropriate structural items (8) to (20) and (31) as shown on diagram of typical transverse section, 7-A-15/Figures 3 and 5.
2. The exact frame station of measurement is to be stated.
3. The single measurements recorded are to represent the average of multiple measurements.
4. The remaining corrosion addition is to be recorded with result of gauged thickness minus renewal thickness. If the result is negative, the structure in way shall be renewed, and the mark “R” is to be indicated in the right-hand column. If the result is between 0 and 0.5 mm (0 included), the structure in way shall be additional gauged, and the mark “S” is to be indicated in the right-hand column.

TM4-DSBC(CSR) (1 July 2013)

Report on THICKNESS MEASUREMENT OF TRANSVERSE STRUCTURAL MEMBERS
In the double bottom, hopper side and topside water ballast tanks

Ship's Name _____ Class Identity No. _____ Report No. _____

TANK DESCRIPTION :									
LOCATION OF STRUCTURE :									
STRUCTURAL MEMBER	ITEM	As Built Thickness mm	Voluntary Thickness Addition mm	Renewal Thickness mm (a)	Gauged Thickness mm (b)		Remaining Corr. Addition mm (b) – (a)		
					P	S	P	S	

Operators Signature _____

NOTES - See Reverse

NOTES TO REPORT TM4-DSBC(CSR)

1. This report is to be used for recording the thickness measurement of transverse structural members, comprising of the appropriate structural items (23) to (25) and (34) as shown on diagram of typical transverse section, 7-A-15/Figures 3 and 5.
2. Guidance for areas if measurement is indicated on the diagrams shown on 7-A-15/Figures 1 and 2.
3. The single measurements recorded are to represent the average of multiple measurements.
4. The remaining corrosion addition is to be recorded with result of gauged thickness minus renewal thickness. If the result is negative, the structure in way shall be renewed, and the mark “R” is to be indicated in the right-hand column. If the result is between 0 and 0.5 mm (0 included), the structure in way shall be additional gauged, and the mark “S” is to be indicated in the right-hand column.

TM5-DSBC(CSR) (1 July 2013)

Report on THICKNESS MEASUREMENT OF CARGO HOLD TRANSVERSE BULKHEADS

Ship's Name _____ Class Identity No. _____ Report No. _____

HOLD DESCRIPTION :									
LOCATION OF STRUCTURE :					FRAME NO:				
STRUCTURAL COMPONENT (PLATING/STIFFENER)	As Built Thickness mm	Voluntary Thickness Addition mm	Renewal Thickness mm (a)	Gauged Thickness mm (b)		Remaining Corr. Addition mm (b) – (a)			
				P	S	P	S	P	S

Operators Signature _____

NOTES - See Reverse

NOTES TO REPORT TM5-DSBC(CSR)

1. This report form is to be used for recording the thickness measurement of W.T. transverse bulkheads in cargo holds.
2. Guidance for areas of measurement is indicated on the diagrams shown on 7-A-15/Figures 1 and 2.
3. The single measurements recorded are to represent the average of multiple measurements.
4. The remaining corrosion addition is to be recorded with result of gauged thickness minus renewal thickness. If the result is negative, the structure in way shall be renewed, and the mark “R” is to be indicated in the right-hand column. If the result is between 0 and 0.5 mm (0 included), the structure in way shall be additional gauged, and the mark “S” is to be indicated in the right-hand column.

TM6-DSBC(CSR) (1 July 2013)

Report on THICKNESS MEASUREMENT OF MISCELLANEOUS STRUCTURAL MEMBERS

Ship's Name _____ Class Identity No. _____ Report No. _____

STRUCTURAL MEMBER :						SKETCH			
LOCATION OF STRUCTURE :									
Description	As Built Thk. mm	Voluntary thickness Addition mm	Renewal Thickness mm (a)	Gauged Thickness mm (b)		Remaining Corr. Addition mm (b) – (a)			
				P	S	P		S	

Operators Signature _____

NOTES - See Reverse

NOTES TO REPORT TM6-DSBC(CSR)

1. This report is to be used for recording the thickness measurement of miscellaneous structural members including the structural items (28) as shown on diagram of typical transverse section, 7-A-15/Figures 3 and 5.
2. Guidance for areas of measurement is indicated on 7-A-15/Figures 1 and 2.
3. The single measurements recorded are to represent the average of multiple measurements.
4. The remaining corrosion addition is to be recorded with result of gauged thickness minus renewal thickness. If the result is negative, the structure in way shall be renewed, and the mark “R” is to be indicated in the right-hand column. If the result is between 0 and 0.5 mm (0 included), the structure in way shall be additional gauged, and the mark “S” is to be indicated in the right-hand column.

FIGURE 1
Close-up Survey and Thickness Measurement Areas (1 July 2013)

Typical transverse section
 Areas (A) and (D)

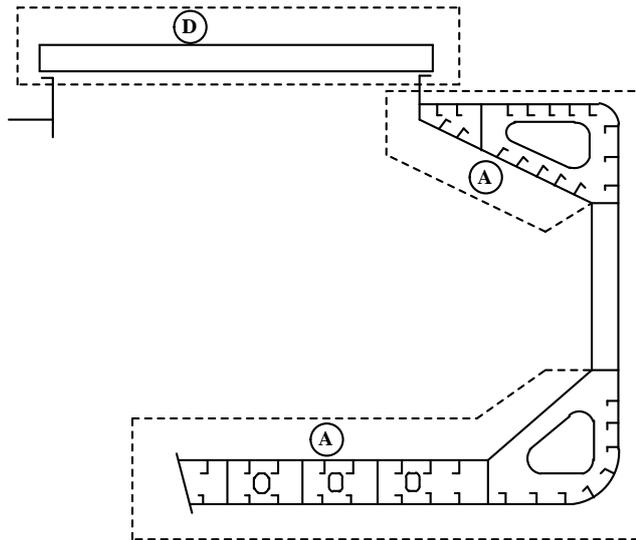

Thickness to be reported on TM3-DSBC, TM4-DSBC and TM6-DSBC or TM3-DSBC(CSR), TM4-DSBC(CSR) and TM6-DSBC(CSR), as appropriate

A cargo hold, transverse bulkhead
 Area (C)

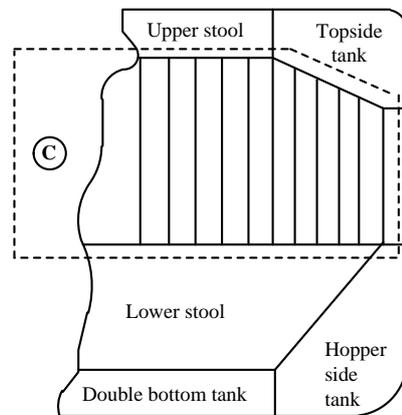

Thickness to be reported on TM5-DSBC or TM5-DSBC(CSR)

Typical areas of deck plating and underdeck structure inside line of hatch openings between cargo hold hatches

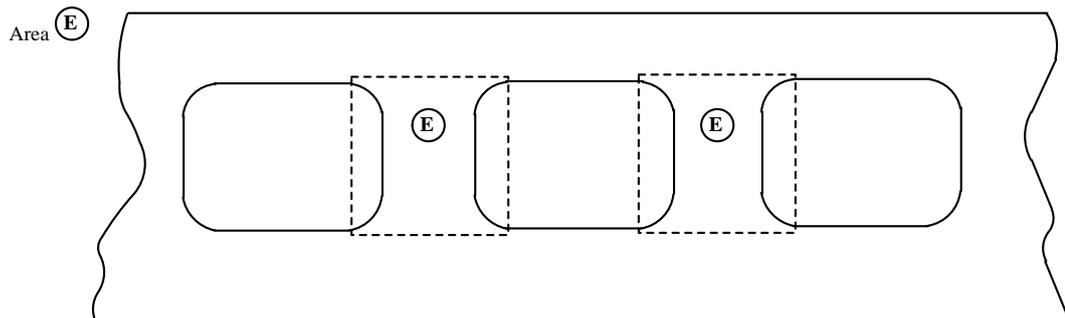

Thickness to be reported on TM6-DSBC or TM6-DSBC(CSR)

FIGURE 2
Close-up Survey and Thickness Measurement Areas
Ordinary Transverse Frame in Double Skin Tank (1 July 2013)

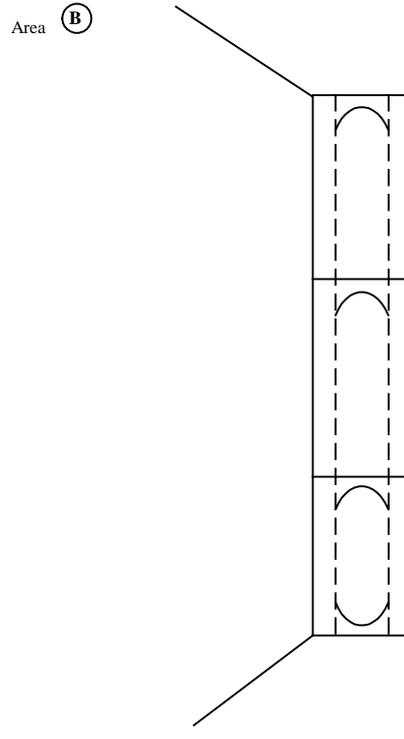

Thickness to be reported on TM4-DSBC(CSR).

FIGURE 3
THICKNESS MEASUREMENT – DOUBLE SKIN BULK CARRIERS (1 July 2013)
 Typical transverse section indicating longitudinal and transverse members

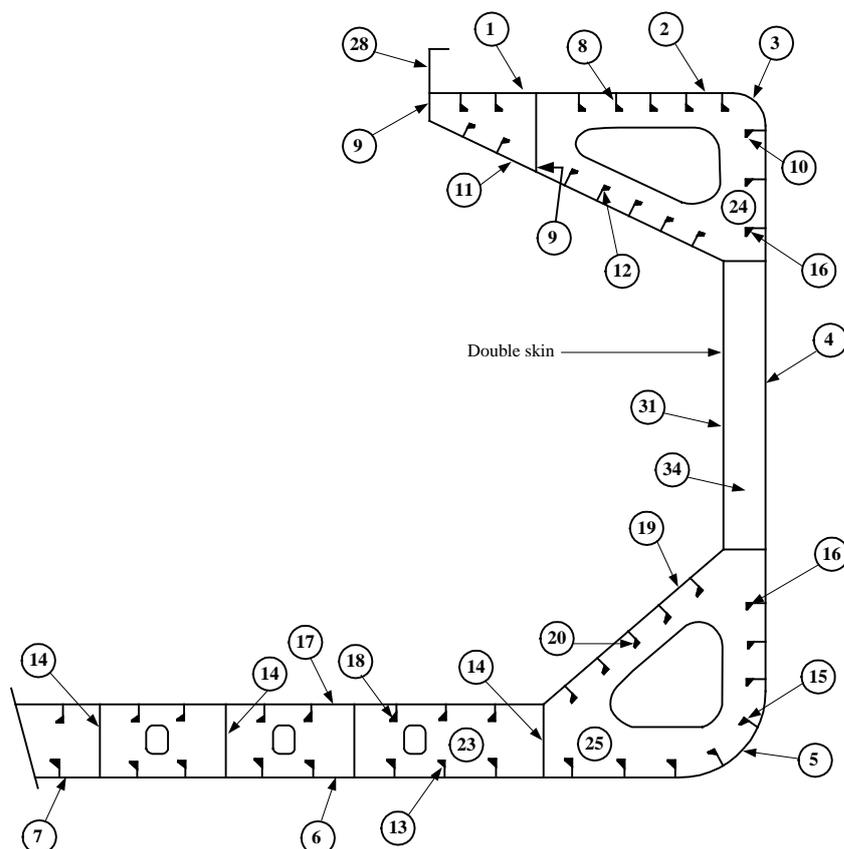

REPORT ON TM2-DSBC (i) & (ii) or TM2-DSBC(CSR) (i) & (ii)	REPORT ON TM3-DSBC or TM3-DSBC(CSR)	
1. Strength deck plating 2. Stringer plate 3. Sheerstrake 4. Side shell plating 5. Bilge plating 6. Bottom shell plating 7. Keel plate	8. Deck longitudinals 9. Deck girders 10. Sheerstrake longitudinals 11. Topside tank sloping plating 12. Topside tank sloping plating longitudinals 13. Bottom longitudinals 14. Bottom girders 15. Bilge longitudinals	16. Side shell longitudinals, if any 17. Inner bottom plating 18. Inner bottom longitudinals 19. Hopper plating 20. Hopper longitudinals 31. Inner side plating - Inner side longitudinals, if any - Horizontal girders in wing ballast tanks
REPORT ON TM4-DSBC or TM4-DSBC(CSR)	REPORT ON TM6-DSBC or TM6-DSBC(CSR)	
23. Double bottom tank floors 24. Topside tank transverses 25. Hopper side tank transverses 34. Transverse web frame - Ordinary transverse frame in double skin tank	28. Hatch coamings - Deck plating between hatches - Hatch covers	

FIGURE 4
Thickness Measurement – Ore Carriers

Typical transverse section of an ore carrier with indication of longitudinal and transverse members

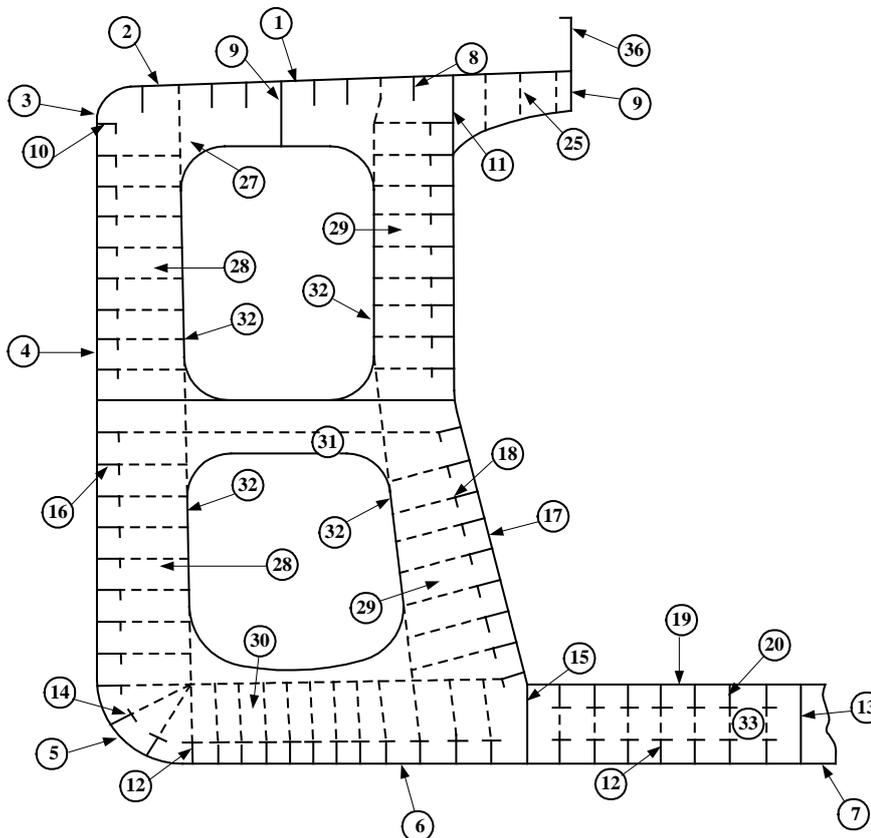

REPORT ON TM2-DSBC(i) & (ii)

- 1. Strength deck plating
- 2. Stringer plate
- 3. Sheerstrake
- 4. Side shell plating
- 5. Bilge plating
- 6. Bottom shell plating
- 7. Keel plate

REPORT ON TM2-DSBC(i) & (ii)

- 36. Hatch coamings
- 37. Deck plating between hatches
- 38. Hatch covers
- 39.
- 40.

REPORT ON TM3-DSBC

- 8. Deck longitudinals
- 9. Deck girders
- 10. Sheerstrake longitudinals
- 11. Longitudinals bulkhead top strake
- 12. Bottom longitudinals
- 13. Bottom girders
- 14. Bilge longitudinals
- 15. Longitudinal bulkhead lower strake
- 16. Side shell longitudinals
- 17. Longitudinal bulkhead plating (remainder)
- 18. Longitudinal bulkhead longitudinals
- 19. Inner bottom plating
- 20. Inner bottom longitudinals
- 21.
- 22.
- 23.
- 24.

REPORT ON TM4-DSBC

- 25. Deck transverse center tank
- 26. Bottom transverse center tank
- 27. Deck transverse wing tank
- 28. Side shell vertical web
- 29. Longitudinal bulkhead vertical web
- 30. Bottom transverse wing tank
- 31. Struts
- 32. Transverse web face plate
- 33. D.B. Floors
- 34.
- 35.

FIGURE 5
Bulk Carriers: Transverse Section Outline (1 July 2013)

This diagram may be used for those ships where the diagram in 7-A-15/Figure 3 is not suitable.

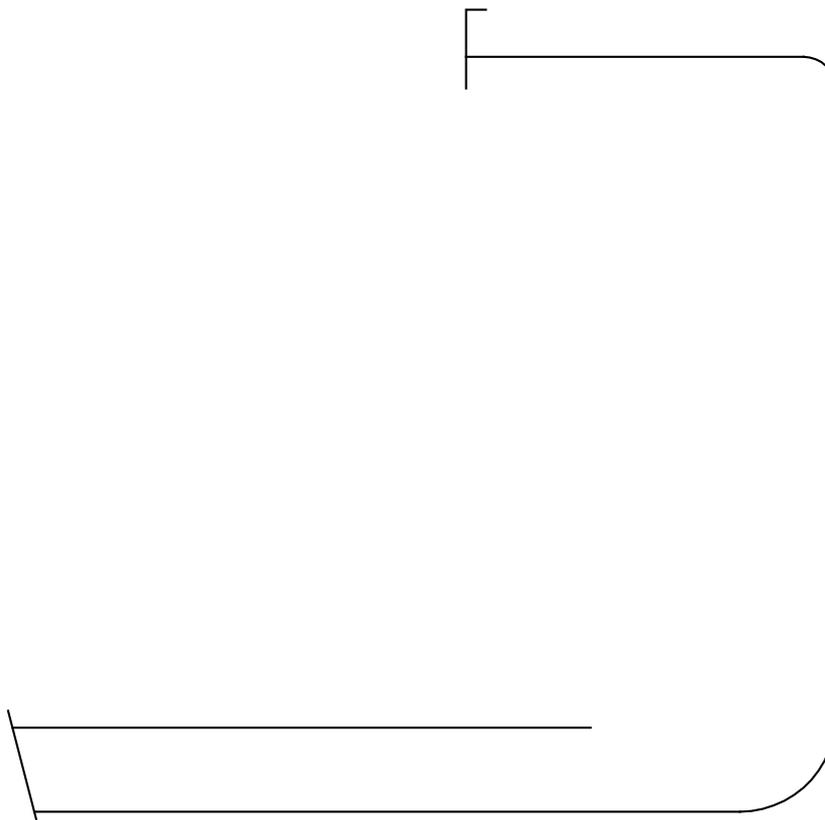

REPORT ON TM2-DSBC (i) & (ii) or TM2-DSBC(CSR) (i) & (ii)
1. Strength deck plating
2. Stringer plate
3. Sheerstrake
4. Side shell plating
5. Bilge plating
6. Bottom shell plating
7. Keel plate

REPORT ON TM3-DSBC or TM3-DSBC(CSR)	
8. Deck longitudinals	16. Side shell longitudinals, if any
9. Deck girders	17. Inner bottom plating
10. Sheerstrake longitudinals	18. Inner bottom longitudinals
11. Topside tank sloping plating	19. Hopper plating
12. Topside tank sloping plating longitudinals	20. Hopper longitudinals
13. Bottom longitudinals	31. Inner side plating
14. Bottom girders	- Inner side longitudinals, if any
15. Bilge longitudinals	- Horizontal girders in wing ballast tanks

REPORT ON TM4-DSBC or TM4-DSBC(CSR)
23. Double bottom tank floors
25. Hopper side tank transverses
34. Transverse web frame
- Topside tank transverses

REPORT ON TM6-DSBC or TM6-DSBC(CSR)
35. Hatch coamings
- Deck plating between hatches
- Hatch covers

FIGURE 6 Thickness Measurement – Ore Carriers

Areas subject to close-up survey and thickness measurements – areas (A) to (E) as defined in 7-3-2/5.19.4 – Thickness to be reported on TM3-DSBC, TM4-DSBC, TM5-DSBC and TM6-DSBC, as appropriate.

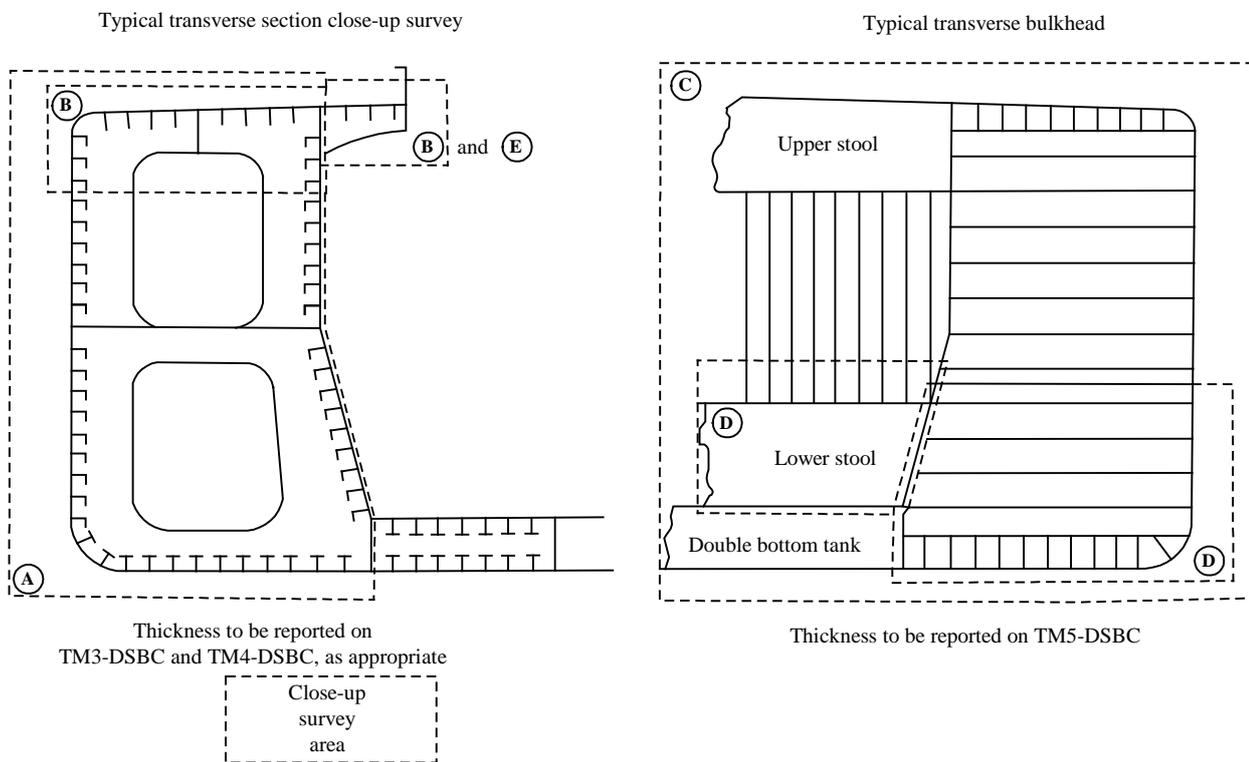
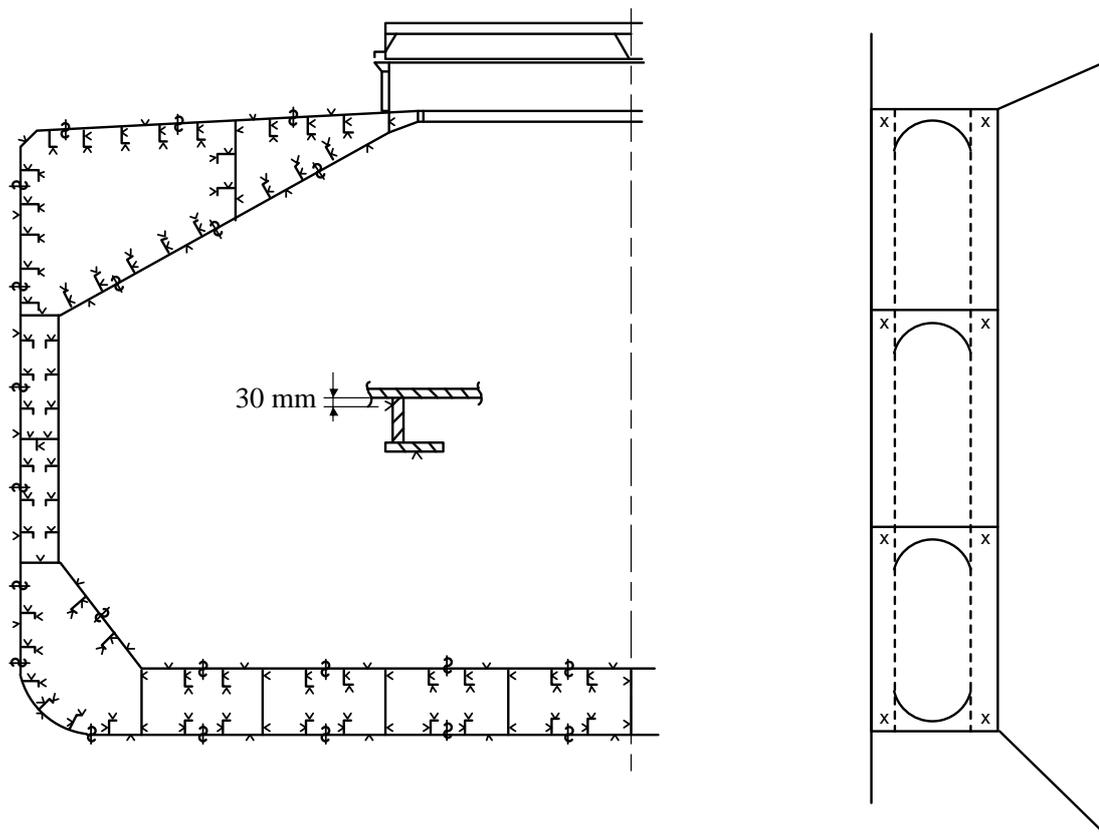

FIGURE 7
Transverse Section of Double Skin Bulk Carrier (1 July 2013)



Double side bulk carrier

Note: Measurements to be taken on both port and starboard sides of the selected transverse section.

FIGURE 8
Locations of Measurements on Hatch Covers and Coamings (1 July 2013)

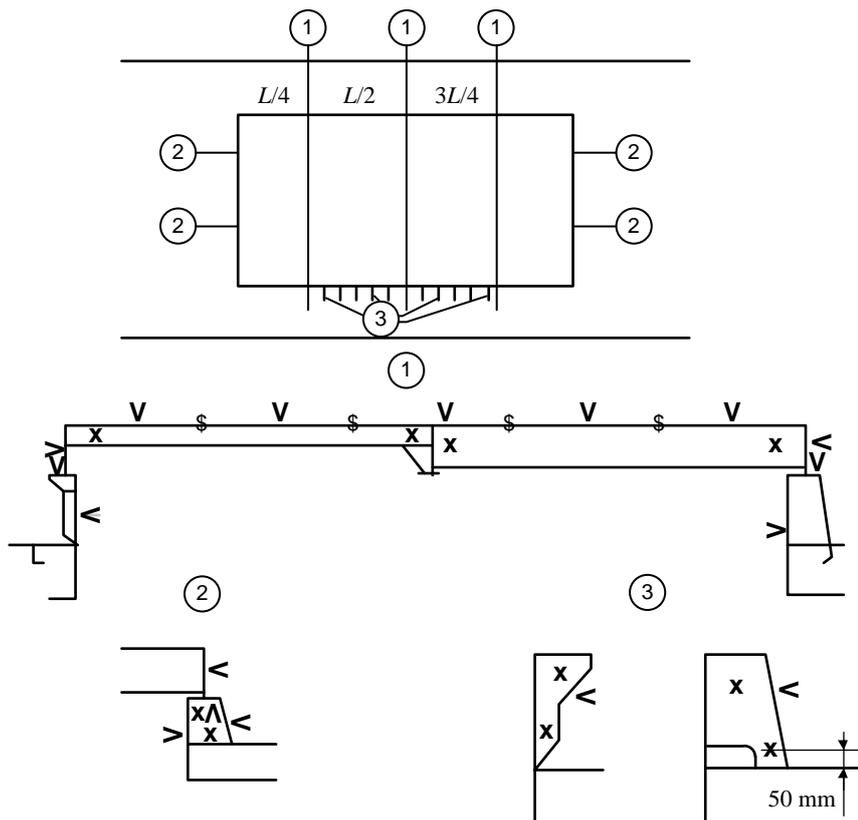

Notes:

- 1 Three sections at $L/4$, $L/2$, $3L/4$ of hatch cover length, including:
 - One measurement of each hatch cover plate and skirt plate
 - Measurements of adjacent beams and stiffeners
 - One measurement of coaming plates and coaming flange, each side
- 2 Measurements of both ends of hatch cover skirt plate, coaming plate, and coaming flange.
- 3 One measurement (two points for web plate and one point for face plate) of one out of three hatch coaming brackets and bars, on both sides and both ends.

FIGURE 9
Locations of Measurements on Structural Members in Ballast Tanks of Double Skin Bulk Carriers (Topside or Hopper Side Tank) (1 July 2013)

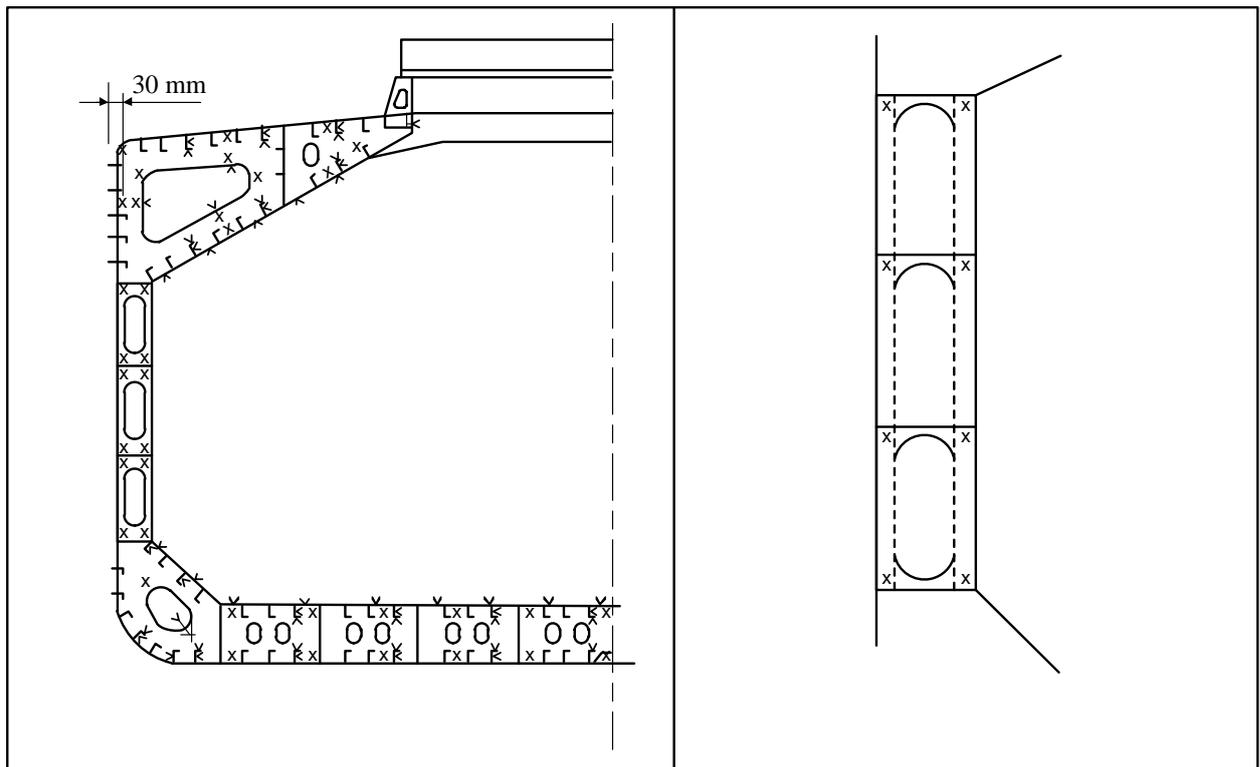
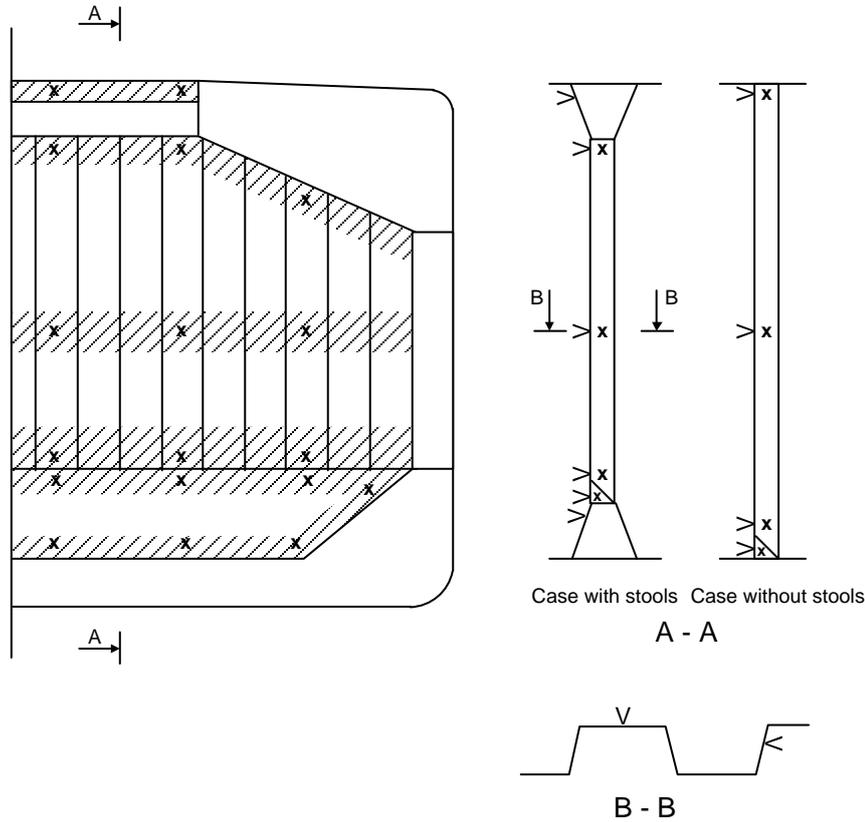

FIGURE 10

Locations of Measurements on Cargo Hold Transverse Bulkheads (1 July 2013)

(Additional measurements to internal structure of upper and lower stools to be added, e.g. two points in the upper and two points in the lower stools to be indicated in section A-A)



Note: Measurements to be taken in each shaded area as per views A - A and B - B.

FIGURE 11
Locations of Measurements on Transverse Bulkheads of Topside, Hopper and Double Bottom Tanks (1 July 2013)

(Two additional measurements to internal structure of double bottom tank to be added at midspan)

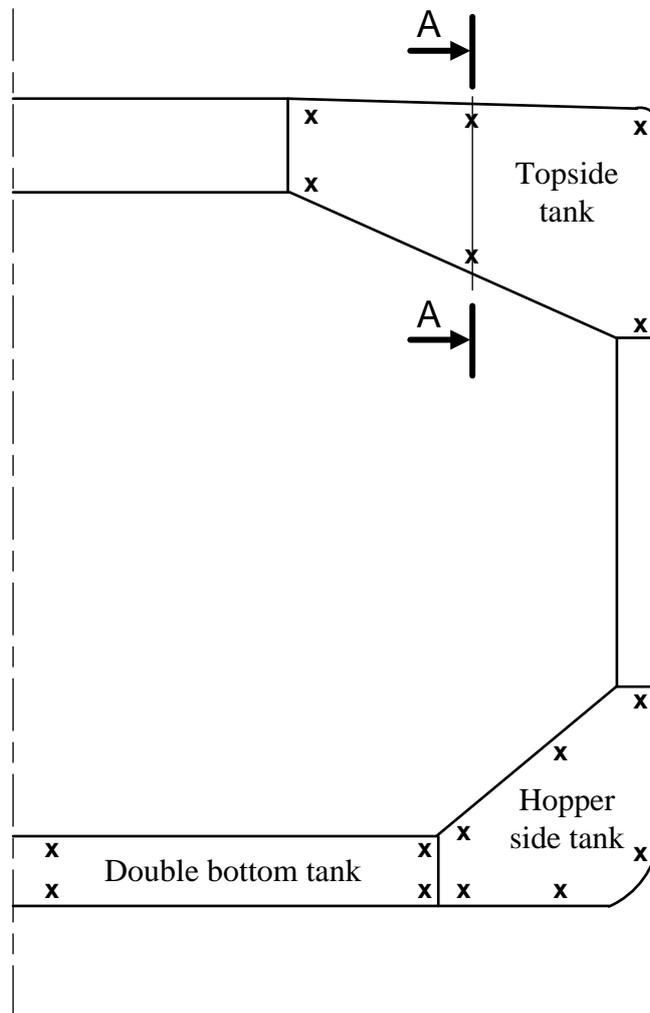

Section A - A

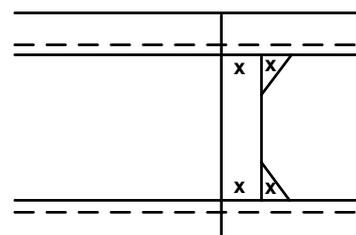

Note: Measurements to be taken in each vertical section as per view A - A.

FIGURE 12
Locations of Measurements on Underdeck Structure (1 July 2013)

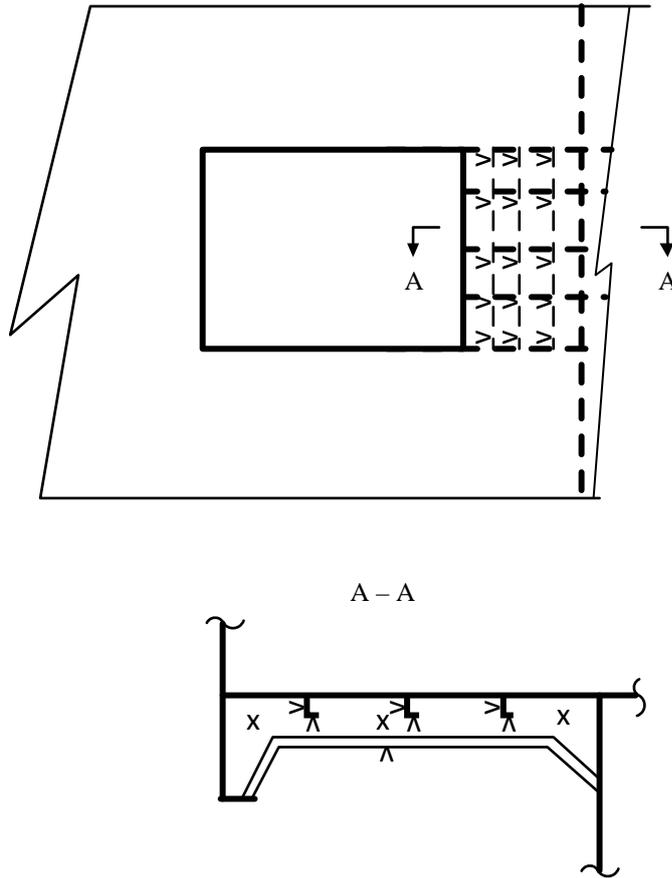

TABLE 1
Interpretations of Rule Requirements for the Locations and Number of Points to be Measured for CSR Bulk Carriers (Double Skin) (1 July 2013)

<i>Item</i>	<i>Interpretation</i>	<i>Figure Reference</i>
Selected plates on deck, tank top, bottom, double bottom and wind-and-water area	<Selected> means at least a single point on one out of three plates, to be chosen on representative areas of average corrosion.	
All deck, tank top and bottom plates and wind-and-water strakes	At least two points on each plate to be taken either at each 1/4 extremity of plate or at representative areas of average corrosion.	
Transverse section	A transverse section includes all longitudinal members such as plating, longitudinals and girders at the deck, side, bottom; inner bottom and hopper sides, inner sides and top wing inner sides.	7-A-15/Figure 7
All cargo hold hatch covers and coamings	Including plates and stiffeners	Locations of points are given in 7-A-15/Figure 8.
Transverse section of deck plating outside line of cargo hatch openings	Two single points on each deck plate (to be taken either at each 1/4 extremity of plate or at representative areas of average corrosion) between the ship sides and hatch coamings in the transverse section concerned	
All deck plating and underdeck structure inside line of hatch openings between cargo hold hatches	<All deck plating> means at least two points on each plate to be taken either at each 1/4 extremity of plate or at representative areas of average corrosion. "Under deck structure": at each short longitudinal girder: three points for web plating (fwd/middle/aft), single point for face plate, one point for web plating and one point for face plating of transverse beam in way. At each ends of transverse beams, one point for web plating and one point for face plating	Extent of areas is shown in 7-A-15/Figure 1. Location of points are given in 7-A-15/Figure 12.
Transverse frame in double skin tank		7-A-15/Figure 7
Transverse bulkheads in cargo holds	Includes bulkhead plating, stiffeners and girders, including internal structure of upper and lower stools, where fitted. Two selected bulkheads: one is to be the bulkhead between the two foremost cargo holds and the second may be chosen in other positions.	Areas of measurements are shown in 7-A-15/Figure 1. Locations of points are given in 7-A-15/Figure 10.
One transverse bulkhead in each cargo hold	This means that the close-up survey and related thickness measurements are to be performed on one side of the bulkhead; the side is to be chosen based on the outcome of the overall survey of both sides. In the event of doubt, the Surveyor may also require (possibly partial) close-up survey on the other side.	Areas of measurements are shown in 7-A-15/Figure 1. Locations of points are given in 7-A-15/Figure 10.

TABLE 1 (continued)
Interpretations of Rule Requirements for the Locations and Number of Points to be Measured for CSR Bulk Carriers (Double Skin) (1 July 2013)

<i>Item</i>	<i>Interpretation</i>	<i>Figure Reference</i>
Transverse bulkheads in one topside, hopper and double bottom ballast tank	Includes bulkhead and stiffening systems. The ballast tank is to be chosen on the history of ballasting among those prone to have the most severe conditions.	Locations of points are given in 7-A-15/Figure 11.
Transverse webs in ballast tanks	Includes web plating, face plates, stiffeners and associated plating and longitudinals. One of the representative tanks of each type (i.e. topside of hopper or side tank) is to be chosen in the forward part.	Areas of measurements are shown in 7-A-15/Figure 1. Locations of points are given in 7-A-15/Figure 9.

PART
7

APPENDIX

SECTION 16 Thickness Measurement and Close-up Survey
Requirements at Special Periodical Surveys
(1 July 2005)

The thickness measurement and Close-up Survey requirements at Special Periodical Surveys given in Section 7-3-2 are tabulated in this Appendix for ready reference and use, as follows:

- Table 1 Thickness Measurement Requirements at Special Periodical Surveys for Vessels without ESP and ESDC Notations – Vessels Under 90 meters (295 feet) in Length; Passenger Vessels and High Speed Craft Under 61 meters (200 feet) in Length
[See also 7-3-2/5.1.15(a)]
- Table 2 Thickness Measurement Requirements at Special Periodical Surveys for Vessels without ESP and ESDC Notations – Non ESP Tankers, Gas and Independent Tank Carriers 90 meters (295 feet) and over in Length
[See also 7-3-2/5.1.15(b)]
- Table 3 Thickness Measurement Requirements at Special Periodical Surveys for Vessels without ESP and ESDC Notations – Vessels 90 meters (295 feet) and over in Length; Passenger Vessels and High Speed Craft 61 meters (200 feet) and over in Length
[See also 7-3-2/5.1.15(c)]
- Table 4 Thickness Measurement Requirements at Special Periodical Surveys – Barges other than Oil/Fuel Oil Tank Barges and Chemical Tank Barges
[See also 7-3-2/5.5.1(f)i]
- Table 5 Thickness Measurement Requirements at Special Periodical Surveys – Oil/Fuel Oil Tank Barges and Chemical Tank Barges under 122 meters (400 feet) in Length
[See also 7-3-2/5.5.1(f)ii]
- Table 6 Thickness Measurement Requirements at Special Periodical Surveys – Bulk Carriers – Non Double Skin ESP and Bulk Carrier Features of Combination Carriers – Non Double Skin ESP
[See also 7-3-2/5.7.5]
- Table 7 Minimum Requirements for CLOSE-UP Examination at Special Periodical Surveys – Bulk Carriers – Non Double Skin ESP and Bulk Carrier Features of Combination Carriers – Non Double Skin ESP
[See also 7-3-2/5.7.4]
- Table 8 Thickness Measurement Requirements at Special Periodical Surveys – Tankers ESP (Oil Carriers and Oil Carrier Features of Combination Carriers – Non-Double Hull) and Oil/Fuel Oil Tank Barges – Non Double Hull and Chemical Tank Barges 122 meters (400 feet) and over in Length
[See also 7-3-2/5.13.5 and 7-3-2/5.5.1(f)iii]

- Table 9 Minimum Requirements for CLOSE-UP Examination at Special Periodical Surveys – Tankers ESP (Oil Carriers and Oil Carrier Features of Combination Carriers – Non-Double Hull) and Oil/Fuel Oil Tank Barges – Non Double Hull and Chemical Tank Barges 122 meters (400 feet) and over in Length
[See also 7-3-2/5.13.4 and 7-3-2/5.5.1(e)]
- Table 10 Thickness Measurement Requirements at Special Periodical Surveys – Tankers ESP (Oil Carriers and Oil Carrier Features of Combination Carriers – Double Hull) and Oil/Fuel Oil Tank Barges – Double Hull 122 meters (400 feet) and over in Length
[See also 7-3-2/5.14.5 and 7-3-2/5.5.1(f)iii]
- Table 11 Minimum Requirements for CLOSE-UP Examination at Special Periodical Surveys – Tankers ESP (Oil Carriers and Oil Carrier Features of Combination Carriers – Double Hull) and Oil/Fuel Oil Tank Barges – Double Hull 122 meters (400 feet) and over in Length
[See also 7-3-2/5.14.4 and 7-3-2/5.5.1(e)]
- Table 12 Thickness Measurement Requirements at Special Periodical Surveys – General Dry Cargo Vessels (ESDC)
[See also 7-3-2/5.15.5]
- Table 13 Minimum Requirements for CLOSE-UP Examination at Special Periodical Surveys – General Dry Cargo Vessels (ESDC)
[See also 7-3-2/5.15.4]
- Table 14 Thickness Measurement Requirements at Special Periodical Surveys – Bulk Carriers – Double Skin ESP and Bulk Carrier Features of Combination Carriers – Double Skin ESP
[See also 7-3-2/5.19.5]
- Table 15 Minimum Requirements for CLOSE-UP Examination at Special Periodical Surveys – Bulk Carriers – Double Skin ESP and Bulk Carrier Features of Combination Carriers – Double Skin ESP, excluding Ore Carriers
[See also 7-3-2/5.19.4]
- Table 16 Thickness Measurement Requirements at Special Periodical Surveys – Chemical Carriers ESP
[See also 7-3-2/5.21.5]
- Table 17 Minimum Requirements for CLOSE-UP Examination at Special Periodical Surveys – Single Hull Chemical Carriers ESP
[See also 7-3-2/5.21.4(b)]
- Table 18 Minimum Requirements for CLOSE-UP Examination at Special Periodical Surveys – Ore Carriers
[See also 7-3-2/5.19.4]
- Table 19 Minimum Requirements for CLOSE-UP Examination at Special Periodical Surveys – Double Hull Chemical Carriers ESP
[See also 7-3-2/5.21.4(c)]

TABLE 1
Thickness Measurement Requirements at Special Periodical Surveys for Vessels
without ESP and ESDC Notations (1 July 2006)

Vessels Under 90 meters (295 feet) in Length; Passenger Vessels and High Speed Craft Under 61 meters (200 feet) in Length
[See also 7-3-2/5.1.15(a)]

i) <i>Special Periodical Survey No. 1</i> <i>(Age ≤ 5 Years)</i>	ii) <i>Special Periodical Survey No. 2</i> <i>(5 < Age ≤ 10 Years)</i>	iii) <i>Special Periodical Survey No. 3</i> <i>(10 < Age ≤ 15 Years)</i>	iv) <i>Special Periodical Survey No. 4</i> <i>and Subsequent</i> <i>(Age > 15 Years)</i> See Notes 1 & 2
1 Suspect areas throughout the vessel.	1 Suspect areas throughout the vessel. 2 One (1) transverse section of deck plating within the midship 0.5L (in way of cargo space, if applicable).	1 Suspect areas throughout the vessel. 2 Two (2) transverse sections within the amidships 0.5L (in way of two (2) different cargo (or ballast) spaces, if applicable). 3 (1 July 2006) Internals in forepeak and afterpeak tanks. 4 All cargo hold hatch covers and coamings (stiffeners and plating).	1 Suspect areas throughout the vessel. 2 Three (3) transverse sections within the amidships 0.5L, (in way of cargo spaces, if applicable), avoiding those spaces previously gauged. 3 Internals in forepeak and after peak tanks. 4 All cargo hold hatch covers and coamings (stiffeners and plating). 5 Lowest strake and strakes in way of tween decks of all transverse bulkheads in cargo spaces together with internals in way. 6 Wind-and-water strakes, port and starboard, full length. 7 All exposed main deck and superstructure deck plating. 8 Flat keel plating full length. Also, additional bottom plates in way of cofferdams, machinery spaces and aft end of tanks. 9 Plating of seachests. Shell plating in way of overboard discharges as considered necessary by the attending Surveyor..

Notes:

- 1 For tank vessels, gauging of principal internals throughout cargo and ballast tanks.
- 2 For High Speed Craft, one (1) additional transverse section forward of 0.125L.

TABLE 2
Thickness Measurement Requirements at Special Periodical Surveys
for Vessels without ESP and ESDC Notations (1 July 2008)

Non ESP Tankers, Gas and Independent Tank Carriers 90 meters (295 feet) and over in Length

[See also 7-3-2/5.1.15(b)]

i) <i>Special Periodical Survey No. 1 (Age ≤ 5 Years)</i>	ii) <i>Special Periodical Survey No. 2 (5 < Age ≤ 10 Years)</i>	iii) <i>Special Periodical Survey No. 3 (10 < Age ≤ 15 Years)</i>	iv) <i>Special Periodical Survey No. 4 and Subsequent (Age > 15 Years)</i>
<p>1 Suspect areas throughout the vessel. 2 (1 July 2008) Additionally for Liquefied Gas Carriers, one section of deck plating for the full beam of the ship within 0.5L amidships in way of a ballast tank, if any.</p>	<p>1 All main deck plates within the amidships 0.5L or cargo tank section, whichever is longer. 2 One (1) transverse section within 0.5L. 3 Plates in wind-and-water strakes outside 0.5L. 4 (2006) All complete transverse web frame rings in a ballast wing tank or ballast double hull tank, if any. 5 (2006) One (1) deck transverse in each of the remaining ballast tanks, if any. 6 (2006) Both transverse bulkheads including girder system in a ballast wing tank or ballast double hull tank, if any, or a cargo wing tank used primarily for water ballast. 7 (2006) Lower part of transverse bulkhead including girder system in each remaining ballast tank, one (1) cargo wing tank and two (2) cargo center tanks. 8 Internals in forepeak, ballast and afterpeak tanks. 9 Suspect areas throughout the vessel.</p>	<p>1 All main deck plates within the amidships 0.5L or cargo tank, whichever is longer. 2 Two (2) transverse sections within the amidships 0.5L. 3 Plates in wind-and-water strakes outside 0.5L. 4 (1 July 2008) Additionally for Liquefied Gas Carriers, all wind and water strakes within the cargo area. 5 (2006) All complete transverse web frame rings in all ballast tanks and in a cargo wing tank. 6 (2006) A minimum of 30% of all complete transverse web frame rings in each remaining cargo wing tank. (In calculating the 30% minimum, the number of web frame rings is to be rounded up to the next whole integer.) 7 (2006) A minimum of 30% of deck and bottom transverse in each cargo center tank. (In calculating the 30% minimum, the number of transverses is to be rounded up to the next whole integer.) 8 (2006) All transverse bulkheads including girder and stiffener systems in all cargo and ballast tanks.</p>	<p>1 All exposed main deck plates, full length. Also, exposed first-tier superstructure deck plates (poop bridge and forecastle decks). 2 All keel plates full length. Also, additional bottom plates in way of cofferdams, machinery space and aft end of tanks. 3 (1 July 2008) Additionally for Liquefied Gas Carriers, duct keel plating and internals, and each bottom plate within the cargo area. 4 A minimum of three (3) transverse sections within the amidships 0.5L. 5 (2006) All complete transverse web frame rings in all ballast tanks and in a cargo wing tank. 6 (2006) A minimum of 30% of all complete transverse web frame rings in each remaining cargo wing tank. (In calculating the 30% minimum, the number of web frame rings is to be rounded up to the next whole integer.) 7 (2006) A minimum of 30% of deck and bottom transverse in each cargo center tank. (In calculating the 30% minimum, the number of transverses is to be rounded up to the next whole integer.)</p>

TABLE 2 (continued)
Thickness Measurement Requirements at Special Periodical Surveys
for Vessels without ESP and ESDC Notations (1 July 2008)

Non ESP Tankers, Gas and Independent Tank Carriers 90 meters (295 feet) and over in Length

[See also 7-3-2/5.1.15(b)]

i) <i>Special Periodical Survey No. 1 (Age ≤ 5 Years)</i>	ii) <i>Special Periodical Survey No. 2 (5 < Age ≤ 10 Years)</i>	iii) <i>Special Periodical Survey No. 3 (10 < Age ≤ 15 Years)</i>	iv) <i>Special Periodical Survey No. 4 and Subsequent (Age > 15 Years)</i>
		9 (2006) Additional complete transverse web frame rings as considered necessary by the Surveyor. 10 (2006) Internals in forepeak and afterpeak tanks including plating and stiffeners of forepeak and afterpeak tank bulkheads. 11 Suspect areas throughout the vessel.	8 (2006) All transverse bulkheads including girder and stiffener systems in all cargo and ballast tanks. 9 (2006) Additional complete transverse web frame rings as considered necessary by the Surveyor. 10 (2006) Any additional tanks and structure as considered necessary by the Surveyor. 11 (2006) Internals in forepeak and afterpeak tanks including plating and stiffeners of forepeak and afterpeak tank bulkheads. 12 All plates in two (2) wind-and-water strakes, port and starboard full length. 13 Suspect areas throughout the vessel. 14 Plating of seachests. Shell plating in way of overboard discharges as considered necessary by the attending Surveyor.

TABLE 3
Thickness Measurement Requirements at Special Periodical Surveys for Vessels without ESP and ESDC Notations
Vessels 90 meters (295 feet) and over in Length; Passenger Vessels and High Speed Craft 61 meters (200 feet) and over in Length
[See also 7-3-2/5.1.15(c)]

i) <i>Special Periodical Survey No. 1 (Age ≤ 5 Years)</i>	ii) <i>Special Periodical Survey No. 2 (5 < Age ≤ 10 Years)</i>	iii) <i>Special Periodical Survey No. 3 (10 < Age ≤ 15 Years)</i>	iv) <i>Special Periodical Survey No. 4 and Subsequent (Age > 15 Years)</i>
1 Suspect areas throughout the vessel.	1 Suspect areas throughout the vessel. 2 One (1) transverse section of deck plating within the amidships 0.5L (in way of a cargo space, if applicable).	1 Suspect areas throughout the vessel. 2 Two (2) transverse sections within the amidships 0.5L (in way of two (2) different cargo spaces, if applicable). 3 Internals in forepeak and afterpeak tanks including plating and stiffeners of forepeak and afterpeak tank bulkheads. 4 All cargo hold hatch covers and coamings (plating and stiffeners).	1 Suspect areas throughout the vessel. 2 A minimum of three (3) transverse sections within the amidships 0.5L (in way of cargo spaces, if applicable). 3 Internals in forepeak and afterpeak tanks including plating and stiffeners of forepeak and afterpeak tank bulkheads. 4 All cargo hold hatch covers and coamings (plating and stiffeners). 5 Lowest strakes and strakes in way of tween decks of all transverse bulkheads in cargo space together with internals in way. 6 All plates in two (2) wind-and-water strakes, port and starboard, full length. 7 All exposed main deck plates full length and all exposed first-tier superstructure deck plates (poop, bridge and forecastle decks). 8 All keel plates full length. Also, additional bottom plates in way of cofferdams, machinery space and aft end of tanks. 9 Duct keel or pipe tunnel plating and internals. 10 Plating of seachests. Shell plating in way of overboard discharges as considered necessary by the attending Surveyor.

TABLE 4
Thickness Measurement Requirements at Special Periodical Surveys
Barges other than Oil/Fuel Oil Tank Barges and Chemical Tank Barges
[See also 7-3-2/5.5.1(f)i]

a <i>Special Periodical Survey No. 1 (Age ≤ 5 Years)</i>	b <i>Special Periodical Survey No. 2 (5 < Age ≤ 10 Years)</i>	c <i>Special Periodical Survey No. 3 (10 < Age ≤ 15 Years)</i>	d <i>Special Periodical Survey No. 4 and Subsequent (Age > 15 Years)</i>
1 Areas considered suspect by the Surveyor, throughout the barge.	1 Areas considered suspect by the Surveyor, throughout the barge.	1 Areas considered suspect by the Surveyor, throughout the barge. 2 Two (2) transverse sections within the midship half length.	1 Areas considered suspect by the Surveyor, throughout the barge. 2 Three (3) transverse sections within the midship half-length. 3 Two (2) wind and water strakes, port and starboard, for the full length. 4 All exposed main deck and superstructure deck plating. 5 Flat keel plating full length, plus all bottom plating.

TABLE 5
Thickness Measurement Requirements at Special Periodical Surveys
Oil/Fuel Oil Tank Barges and Chemical Tank Barges under 122 meters (400 feet) in Length
[See also 7-3-2/5.5.1(f)ii]

a <i>Special Periodical Survey No. 1 (Age ≤ 5 Years)</i>	b <i>Special Periodical Survey No. 2 (5 < Age ≤ 10 Years)</i>	c <i>Special Periodical Survey No. 3 (10 < Age ≤ 15 Years)</i>	d <i>Special Periodical Survey No. 4 and Subsequent (Age > 15 Years)</i>
1 Areas considered suspect by the Surveyor, throughout the barge.	1 Areas considered suspect by the Surveyor, throughout the barge.	1 Areas considered suspect by the Surveyor, throughout the barge. 2 Two (2) transverse sections within the midship half-length in way of two (2) different cargo (or ballast) tanks.	1 Areas considered suspect by the Surveyor, throughout the barge. 2 Three (3) transverse sections within the midship half-length avoiding those tanks previously gauged. 3 Transverse webs with associated plating and longitudinals in way of the three (3) transverse sections required above. 4 All transverse bulkheads including stiffening system in all ballast and cargo tanks. 5 Two (2) wind and water strakes, port and starboard, for the full length. 6 All exposed main deck and superstructure deck plating. 7 Flat keel plating full length, plus all bottom plating.

TABLE 6
Thickness Measurement Requirements at Special Periodical Surveys (1 July 2006)
Bulk Carriers – Non Double Skin ESP and Bulk Carrier Features of Combination Carriers – Non Double Skin ESP
[See also 7-3-2/5.7.5]

<i>(a) Special Periodical Survey No. 1 (Age ≤ 5 Years)</i>	<i>(b) Special Periodical Survey No. 2 (5 < Age ≤ 10 Years) (1 July 2006)</i>	<i>(c) Special Periodical Survey No. 3 (10 < Age ≤ 15 Years) (1 July 2006)</i>	<i>(d) Special Periodical Survey No. 4 and Subsequent (Age > 15 Years) (1 July 2006)</i>
<ul style="list-style-type: none"> <i>i)</i> Suspect areas throughout the vessel. <i>ii)</i> Measurement, for general assessment and recording of corrosion patterns, of structural members subject to Close-up Survey. 	<ul style="list-style-type: none"> <i>i)</i> Suspect areas throughout the vessel. <i>ii)</i> All deck plating inside the line of opening between cargo hold hatches. <i>iii)</i> (1 July 2006) Two (2) transverse sections of deck plating outside the line of cargo hatch openings within the amidships 0.5L. <i>iv)</i> Plates in two (2) wind-and-water strakes in way of the same transverse sections. <i>v)</i> (1 July 2006) Selected wind-and-water strakes outside the cargo length area. <i>vi)</i> All cargo hold hatch covers and coamings (plating and stiffeners) <i>vii)</i> Measurement, for general assessment and recording of corrosion patterns, of structural members subject to Close-up Survey. <i>viii)</i> Measurements of the corrugated transverse watertight bulkhead between cargo holds No's. one and two, for vessels subject to IACS UR S19 and IACS UR S23. 	<ul style="list-style-type: none"> <i>i)</i> Suspect areas throughout the vessel. <i>ii)</i> (1 July 2006) All main deck plating within the cargo length area. <i>iii)</i> Two (2) transverse sections, one (1) in the amidship area, outside the line of cargo hatch openings within the amidships 0.5L. <i>iv)</i> All plating in two (2) wind-and-water strakes, port and starboard, full length. <i>v)</i> All cargo hold hatch covers and coamings (plating and stiffeners). <i>vi)</i> Plating and stiffeners of transverse bulkheads. <i>vii)</i> (1 July 2006) Internals in forepeak and afterpeak tanks, including plating and stiffeners of bulkheads. <i>viii)</i> Measurement, for general assessment and recording of corrosion pattern, of structural members subject to Close-up Survey. <i>ix)</i> Measurements of the corrugated transverse watertight bulkhead between cargo holds No's. one and two, for vessels subject to IACS UR S19 and IACS UR S23. 	<ul style="list-style-type: none"> <i>i)</i> Suspect areas throughout the vessel. <i>ii)</i> (1 July 2006) All main deck plating within the cargo length area, all exposed main deck plating outside of the cargo length area, and all exposed first tier superstructure deck plates (poop, bridge and forecastle decks). <i>iii)</i> A minimum of three (3) transverse sections, one (1) in the amidship area, outside of the line of cargo hatch openings within the amidships 0.5L. <i>iv)</i> All plating in two (2) wind-and-water strakes, port and starboard, full length. <i>v)</i> All cargo hold hatch covers and coamings (plating and stiffeners). <i>vi)</i> Plating and stiffeners of transverse bulkheads <i>vii)</i> (1 July 2006) Internals in forepeak and afterpeak tanks, including plating and stiffeners of bulkheads. <i>viii)</i> Duct keel or pipe tunnel plating and internals. <i>ix)</i> All keel and bottom plates full length.

TABLE 6 (continued)
Thickness Measurement Requirements at Special Periodical Surveys (1 July 2006)
Bulk Carriers – Non Double Skin ESP and Bulk Carrier Features of Combination Carriers – Non Double Skin ESP
 [See also 7-3-2/5.7.5]

<i>(a) Special Periodical Survey No. 1 (Age ≤ 5 Years)</i>	<i>(b) Special Periodical Survey No. 2 (5 < Age ≤ 10 Years) (1 July 2006)</i>	<i>(c) Special Periodical Survey No. 3 (10 < Age ≤ 15 Years) (1 July 2006)</i>	<i>(d) Special Periodical Survey No. 4 and Subsequent (Age > 15 Years) (1 July 2006)</i>
	<p><i>ix)</i> Additional thickness measurements to be taken of the cargo hold side shell frames and brackets on ships subject to compliance with IACS UR S31 for initial and continued compliance.</p>	<p><i>x)</i> Additional thickness measurements to be taken of the cargo hold side shell frames and brackets on ships subject to compliance with IACS UR S31 for initial and continued compliance.</p>	<p><i>x)</i> Plating of seachests. Shell plating in way of overboard discharges as considered necessary by the attending Surveyor.</p> <p><i>xi)</i> Measurement, for general assessment and recording of corrosion patterns of structural members subject to Close-up Survey.</p> <p><i>xii)</i> Measurements of the corrugated transverse watertight bulkhead between cargo holds No's. one and two, for vessels subject to IACS UR S19 and IACS UR S23.</p> <p><i>xiii)</i> Additional thickness measurements to be taken of the cargo hold side shell frames and brackets on ships subject to compliance with IACS UR S31 for initial and continued compliance.</p>

TABLE 7
Minimum Requirements for CLOSE-UP Examination at Special Periodical Surveys (1 July 2016)
Bulk Carriers – Non Double Skin ESP and Bulk Carrier Features of Combination Carriers – Non Double Skin ESP
[See also 7-3-2/5.7.4]

(a) <i>Special Periodical Survey No. 1 (Age ≤ 5 Years)</i>	(b) <i>Special Periodical Survey No. 2 (5 < Age ≤ 10 Years)</i>	(c) <i>Special Periodical Survey No. 3 (10 < Age ≤ 15 Years)</i>	(d) <i>Special Periodical Survey No. 4 and Subsequent (Age > 15 Years)</i>
<p><i>i)</i> 25% of shell frames in the forward cargo hold at representative positions. Representative frames in remaining cargo holds. (See 7-A-6/Figure 3 Area A)</p> <p><i>ii)</i> (1 July 2006) One (1) transverse web with associated plating and longitudinals in two (2) representative ballast tanks of each type: topside or hopper side tanks. (See 7-A-6/Figure 3 Area B)</p> <p><i>iii)</i> (1 July 2006) Two (2) cargo hold transverse bulkheads plating, stiffeners and girders, including internal structure of upper and lower stools, where fitted. (See 7-A-6/Figure 3 Area C)</p> <p><i>iv)</i> (1 July 2016) All cargo hold hatch covers and coamings plating and stiffeners. For cargo hold hatch covers of approved design which structurally have no access to the internals, close-up survey/thickness measurements shall be done of accessible parts of hatch covers structures. (See 7-A-6/Figure 3 Area D)</p>	<p><i>i)</i> (1 July 2007) All shell frames in the forward cargo hold and 25% of frames in each of the remaining cargo holds including upper and lower end attachments and adjacent shell plating. For bulk carriers 100,000 DWT and above, all shell frames in the No. 1 forward cargo hold and 50% of shell frames in each of the remaining cargo holds, including upper and lower end attachments and adjacent shell plating. (See 7-A-6/Figure 3 Area A)</p> <p><i>ii)</i> One (1) transverse web with associated plating and longitudinals in all ballast tanks. (See 7-A-6/Figure 3 Area B)</p> <p><i>iii)</i> Forward and aft transverse bulkheads in one (1) topside ballast tank, including stiffening systems. (See 7-A-6/Figure 3 Area B)</p> <p><i>iv)</i> (1 July 2006) All cargo hold transverse bulkheads plating, stiffeners and girders, including internal structure of upper and lower stools, where fitted. (See 7-A-6/Figure 3 Area C)</p> <p><i>v)</i> All deck plating and under deck structure inside line of hatch openings between all cargo hold hatches. (See 7-A-6/Figure 3 Area E)</p>	<p><i>i)</i> All shell frames in the forward cargo hold and one other selected cargo hold, and 50% of frames in each of the remaining cargo holds, including the upper and lower end attachments and adjacent shell plating. (See 7-A-6/Figure 3 Area A)</p> <p><i>ii)</i> All transverse web with associated plating and longitudinals in all ballast tanks. (See 7-A-6/Figure 3 Area B)</p> <p><i>iii)</i> All transverse bulkheads in ballast tanks, including stiffening systems (See 7-A-6/Figure 3 Area B)</p> <p><i>iv)</i> (1 July 2006) All cargo holds transverse bulkheads plating, stiffeners and girders, including internal structure of upper and lower stools, where fitted. (See 7-A-6/Figure 3 Area C)</p> <p><i>v)</i> All deck plating and under deck structure inside the line of hatch openings between all cargo hold hatches. (See 7-A-6/Figure 3 Area E)</p>	<p><i>i)</i> All shell frames in all cargo holds including upper and lower end attachments and adjacent shell plating. (See 7-A-6/Figure 3 Area A)</p> <p><i>ii)</i> All transverse webs with associated plating and longitudinals in all ballast tanks. (See 7-A-6/Figure 3 Area B)</p> <p><i>iii)</i> All transverse bulkheads in ballast tanks, including stiffening systems (See 7-A-6/Figure 3 Area B)</p> <p><i>iv)</i> (1 July 2006) All cargo holds transverse bulkheads plating, stiffeners and girders, including internal structure of upper and lower stools, where fitted. (See 7-A-6/Figure 3 Area C)</p> <p><i>v)</i> All deck plating and under deck structure inside the line of hatch openings between all cargo hold hatches. (See 7-A-6/Figure 3 Area E)</p>

TABLE 7 (continued)
Minimum Requirements for CLOSE-UP Examination at Special Periodical Surveys (1 July 2016)
Bulk Carriers – Non Double Skin ESP and Bulk Carrier Features of Combination Carriers – Non Double Skin ESP
 [See also 7-3-2/5.7.4]

<i>(a) Special Periodical Survey No. 1 (Age ≤ 5 Years)</i>	<i>(b) Special Periodical Survey No. 2 (5 < Age ≤ 10 Years)</i>	<i>(c) Special Periodical Survey No. 3 (10 < Age ≤ 15 Years)</i>	<i>(d) Special Periodical Survey No. 4 and Subsequent (Age > 15 Years)</i>
	vi) (1 July 2016) All cargo hatch covers and coamings plating and stiffeners. For cargo hold hatch covers of approved design which structurally have no access to the internals, close-up survey/thickness measurements shall be done of accessible parts of hatch covers structures. (See 7-A-6/Figure 3 Area D)	vi) (1 July 2016) All cargo hatch covers and coamings plating and stiffeners. For cargo hold hatch covers of approved design which structurally have no access to the internals, close-up survey/thickness measurements shall be done of accessible parts of hatch covers structures. (See 7-A-6/Figure 3 Area D)	vi) (1 July 2016) All cargo hatch covers and coamings plating and stiffeners. For cargo hold hatch covers of approved design which structurally have no access to the internals, close-up survey/thickness measurements shall be done of accessible parts of hatch covers structures. (See 7-A-6/Figure 3 Area D)

TABLE 8
Thickness Measurement Requirements at Special Periodical Surveys (1 July 2006)
Tankers ESP (Oil Carriers and Oil Carrier Features of Combination Carriers – Non-Double Hull)
and Oil/Fuel Oil Tank Barges – Non Double Hull and Chemical Tank Barges 122 meters (400 feet) and over in Length
[See also 7-3-2/5.13.5 and 7-3-2/5.5.1(f)iii]

<i>(a) Special Periodical Survey No. 1 (Age ≤ 5 Years) (1 July 2006)</i>	<i>(b) Special Periodical Survey No. 2 (5 < Age ≤ 10 Years) (1 July 2006)</i>	<i>(c) Special Periodical Survey No. 3 (10 < Age ≤ 15 Years) (1 July 2006)</i>	<i>(d) Special Periodical Survey No. 4 and Subsequent (Age > 15 Years) (1 July 2006)</i>
<ul style="list-style-type: none"> <i>i)</i> Suspect areas throughout the vessel. <i>ii)</i> One (1) transverse section of deck plating for the full beam of the ship within amidships 0.5L, in way of a ballast tank, if any, or a cargo tank used primarily for water ballast. <i>iii)</i> Measurement, for general assessment and recording of corrosion patterns, of structural members subject to Close-up Surveys. 	<ul style="list-style-type: none"> <i>i)</i> Suspect areas throughout the vessel. <i>ii)</i> All main deck plating within the amidships 0.5L or cargo area, whichever is longer. <i>iii)</i> One (1) transverse section within the amidships 0.5L. <i>iv)</i> Plating in two (2) wind-and-water strakes outside amidships 0.5L. <i>v)</i> Internals in forepeak and afterpeak tanks, including plating and stiffeners of forepeak and afterpeak tank bulkheads. <i>vi)</i> Measurement for general assessment and recording of corrosion patterns of structural members subject to Close-up Survey. 	<ul style="list-style-type: none"> <i>i)</i> Suspect areas throughout the vessel. <i>ii)</i> All main deck plating within the amidships 0.5L or cargo area, whichever is longer. <i>iii)</i> (1 July 2006) Two (2) transverse sections, including at least one (1) in way of a ballast tank, within the amidships 0.5L. <i>iv)</i> All plating in two (2) wind-and-water strakes, port and starboard, full length. <i>v)</i> Internals in forepeak and afterpeak tanks, including plating and stiffeners of forepeak and afterpeak tank bulkheads. <i>vi)</i> Measurement, for general assessment and recording of corrosion patterns, of structural members subject to Close-up Survey. 	<ul style="list-style-type: none"> <i>i)</i> Suspect areas throughout the vessel. <i>ii)</i> All main deck plating within the cargo area, all exposed main deck plating outside of cargo area and all exposed 1st tier superstructure deck plating (poop, bridge and forecastle decks). <i>iii)</i> (1 July 2006) A minimum of three (3) transverse sections, including at least one (1) in way of a ballast tank, within the amidships 0.5L. <i>iv)</i> All plating in two (2) wind-and-water strakes, port and starboard, full length. <i>v)</i> Internals in forepeak and afterpeak tanks, including plating and stiffeners of forepeak and afterpeak tank bulkheads. <i>vi)</i> (1 July 2006) Duct keel or pipe tunnel plating and internals. <i>vii)</i> All keel and bottom plating, full length. <i>viii)</i> Plating of seachests. Shell plating in way of overboard discharges as considered necessary by the attending Surveyor.

TABLE 8 (continued)
Thickness Measurement Requirements at Special Periodical Surveys (1 July 2006)
Tankers ESP (Oil Carriers and Oil Carrier Features of Combination Carriers – Non-Double Hull)
and Oil/Fuel Oil Tank Barges – Non Double Hull and Chemical Tank Barges 122 meters (400 feet) and over in Length
[See also 7-3-2/5.13.5 and 7-3-2/5.5.1(f)iii]

(a) <i>Special Periodical Survey No. 1 (Age ≤ 5 Years) (1 July 2006)</i>	(b) <i>Special Periodical Survey No. 2 (5 < Age ≤ 10 Years) (1 July 2006)</i>	(c) <i>Special Periodical Survey No. 3 (10 < Age ≤ 15 Years) (1 July 2006)</i>	(d) <i>Special Periodical Survey No. 4 and Subsequent (Age > 15 Years) (1 July 2006)</i>
			ix) Measurements, for general assessment and recording of corrosion patterns, of structural members subject to Close-up Survey.

Note: In the case of oil tankers of 130 meters (427 feet) in length and upwards, for the evaluation of the vessel's longitudinal strength as required in 7-3-2/15.1.2, the sampling method of thickness measurements is given in 7-A-4/33..

TABLE 9
Minimum Requirements for CLOSE-UP Examination at Special Periodical Surveys (1 July 2006)
Tankers ESP (Oil Carriers and Oil Carrier Features of Combination Carriers – Non-Double Hull)
and Oil/Fuel Oil Tank Barges – Non Double Hull and Chemical Tank Barges 122 meters (400 feet) and over in Length
[See also 7-3-2/5.13.4 and 7-3-2/5.5.1(e)]

<i>(a) Special Periodical Survey No. 1 (Age ≤ 5 Years)</i>	<i>(b) Special Periodical Survey No. 2 (5 < Age ≤ 10 Years)</i>	<i>(c) Special Periodical Survey No. 3 (10 < Age ≤ 15 Years)</i>	<i>(d) Special Periodical Survey No. 4 and Subsequent (Age > 15 Years)</i>
<p><i>i) (1 July 2006) One (1) complete transverse web frame ring including adjacent structural members in a ballast wing tank, if any, or in a cargo wing tank used primarily for water ballast. (See 7-A-7/Figure 5 Area A)</i></p> <p><i>ii) (1 July 2006) One (1) deck transverse including adjacent structural members in a cargo wing tank. (See 7-A-7/Figure 5 Area B)</i></p> <p><i>iii) (1 July 2006) Lower part of one (1) transverse bulkhead including girder system and adjacent structural member</i></p> <ul style="list-style-type: none"> - In one (1) ballast wing tank. - In one (1) cargo wing tank. - In one (1) cargo center tank. <p><i>(See 7-A-7/Figure 5 Area D)</i></p>	<p><i>i) (1 July 2006) All complete transverse web frame rings including adjacent structural members in a ballast wing tank, if any, or a cargo wing tank used primarily for water ballast. (See 7-A-7/Figure 5 Area A)</i></p> <p><i>ii) (1 July 2006) One (1) deck transverse including adjacent deck structural members.</i></p> <ul style="list-style-type: none"> - In each of the remaining ballast tanks, if any. - In one (1) cargo wing tank. - In two (2) cargo center tanks. <p><i>(See 7-A-7/Figure 5 Area B)</i></p> <p><i>iii) (1 July 2006) Both transverse bulkheads including girder system and adjacent structural members in a ballast wing tank, if any, or a cargo wing tank used primarily for water ballast. (See 7-A-7/Figure 5 Area C)</i></p> <p><i>iv) (1 July 2006) Lower part of one (1) transverse bulkhead including girder system and adjacent structural members.</i></p> <ul style="list-style-type: none"> - In each remaining ballast tank. - In one (1) cargo oil wing tank. - In two (2) cargo center tanks. <p><i>(See 7-A-7/Figure 5 Area D)</i></p>	<p><i>i) (1 July 2006) All complete transverse web frame rings, including adjacent structural members in all ballast tanks and in a cargo wing tank. (See 7-A-7/Figure 5 Area A)</i></p> <p><i>ii) (1 July 2006) A minimum of 30% of all complete transverse web frame rings, including adjacent structural members in each remaining cargo wing tank. (See 7-A-7/Figure 5 Area A) (In calculating the 30% minimum, the number of web frame rings is to be rounded up to the next whole integer.)</i></p> <p><i>iii) (1 July 2006) A minimum of 30% of deck and bottom transverses including adjacent structural members in each cargo center tank. (See 7-A-7/Figure 5 Area E) (In calculating the 30% minimum, the number of transverses is to be rounded up to the next whole integer.)</i></p> <p><i>iv) (1 July 2006) All transverse bulkheads, including girder and stiffener systems and adjacent structural members in all cargo and ballast tanks. (See 7-A-7/Figure 5 Area C)</i></p>	<p><i>i) (1 July 2006) All complete transverse web frame rings including adjacent structural members in all ballast tanks and in a cargo wing tank. (See 7-A-7/Figure 5 Area A)</i></p> <p><i>ii) (1 July 2006) A minimum of 30% of all complete transverse web frame rings including adjacent structural members in each remaining cargo wing tank. (See 7-A-7/Figure 5 Area A) (In calculating the 30% minimum, the number of web frame rings is to be rounded up to the next whole integer.)</i></p> <p><i>iii) (1 July 2006) A minimum of 30% of deck and bottom transverses including adjacent structural members in each cargo center tank. (See 7-A-7/Figure 5 Area E) (In calculating the 30% minimum, the number of transverses is to be rounded up to the next whole integer.)</i></p> <p><i>iv) (1 July 2006) All transverse bulkheads including girder and stiffener systems and adjacent structural members in all cargo and ballast tanks. (See 7-A-7/Figure 5 Area C)</i></p>

TABLE 9 (continued)
Minimum Requirements for CLOSE-UP Examination at Special Periodical Surveys (1 July 2006)
Tankers ESP (Oil Carriers and Oil Carrier Features of Combination Carriers – Non-Double Hull)
and Oil/Fuel Oil Tank Barges – Non Double Hull and Chemical Tank Barges 122 meters (400 feet) and over in Length
[See also 7-3-2/5.13.4 and 7-3-2/5.5.1(e)]

<i>(a) Special Periodical Survey No. 1 (Age ≤ 5 Years)</i>	<i>(b) Special Periodical Survey No. 2 (5 < Age ≤ 10 Years)</i>	<i>(c) Special Periodical Survey No. 3 (10 < Age ≤ 15 Years)</i>	<i>(d) Special Periodical Survey No. 4 and Subsequent (Age > 15 Years)</i>
		<i>v) (1 July 2006) Additional complete transverse web frame rings as considered necessary by the Surveyor. (See 7-A-7/Figure 5 Areas A and E)</i>	<i>v) (1 July 2006) Additional complete transverse web frame rings as considered necessary by the Surveyor. (See 7-A-7/Figure 5 Areas A and E)</i> <i>vi) Any additional tanks and structure as considered necessary by the Surveyor.</i>

TABLE 10
Thickness Measurement Requirements at Special Periodical Surveys (1 July 2006)
Tankers ESP (Oil Carriers and Oil Carrier Features of Combination Carriers – Double Hull)
and Oil/Fuel Oil Tank Barges – Double Hull 122 meters (400 feet) and over in Length

[See also 7-3-2/5.14.5 and 7-3-2/5.5.1(f)iii]

(a) <i>Special Periodical Survey No. 1 (Age ≤ 5 Years) (1 July 2006)</i>	(b) <i>Special Periodical Survey No. 2 (5 < Age ≤ 10 Years) (1 July 2006)</i>	(c) <i>Special Periodical Survey No. 3 (10 < Age ≤ 15 Years) (1 July 2006)</i>	(d) <i>Special Periodical Survey No. 4 and Subsequent (Age > 15 Years) (1 July 2006)</i>
<p><i>i)</i> Suspect areas throughout the vessel.</p> <p><i>ii)</i> (1 July 2006) One (1) transverse section of deck plating for the full beam of the ship within amidships 0.5L, in way of a ballast tank, if any.</p> <p><i>iii)</i> Measurement, for general assessment and recording of corrosion patterns, of structural members subject to Close-up Surveys.</p>	<p><i>i)</i> Suspect areas throughout the vessel.</p> <p><i>ii)</i> All main deck plating within the amidships 0.5L or cargo area, whichever is longer.</p> <p><i>iii)</i> One (1) transverse section within the amidships 0.5L.</p> <p><i>iv)</i> Plating in two (2) wind-and-water strakes outside amidships 0.5L.</p> <p><i>v)</i> Internals in forepeak and afterpeak tanks, including plating and stiffeners of forepeak and afterpeak tank bulkheads.</p> <p><i>vi)</i> Measurement for general assessment and recording of corrosion patterns of structural members subject to Close-up Survey.</p>	<p><i>i)</i> Suspect areas throughout the vessel.</p> <p><i>ii)</i> All main deck plating within the amidships 0.5L or cargo area, whichever is longer.</p> <p><i>iii)</i> (1 July 2006) Two (2) transverse sections, including at least one (1) in way of a ballast tank, within the amidships 0.5L.</p> <p><i>iv)</i> All plating in two (2) wind-and-water strakes, port and starboard, full length.</p> <p><i>v)</i> Internals in forepeak and afterpeak tanks, including plating and stiffeners of forepeak and afterpeak tank bulkheads.</p> <p><i>vi)</i> Measurement, for general assessment and recording of corrosion patterns, of structural members subject to Close-up Survey.</p>	<p><i>i)</i> Suspect areas throughout the vessel.</p> <p><i>ii)</i> All main deck plating within the cargo area, all exposed main deck plating outside of cargo area and all exposed 1st tier superstructure deck plating (poop, bridge and forecastle decks).</p> <p><i>iii)</i> (1 July 2006) A minimum of three (3) transverse sections, including at least one (1) in way of a ballast tank, within the amidships 0.5L.</p> <p><i>iv)</i> All plating in two (2) wind-and-water strakes, port and starboard, full length.</p> <p><i>v)</i> Internals in forepeak and afterpeak tanks, including plating and stiffeners of forepeak and afterpeak tank bulkheads.</p> <p><i>vi)</i> (1 July 2006) Duct keel or pipe tunnel plating and internals.</p> <p><i>vii)</i> All keel and bottom plating full length.</p> <p><i>viii)</i> Plating of seachests. Shell plating in way of overboard discharges as considered necessary by the attending Surveyor.</p>

TABLE 10 (continued)
Thickness Measurement Requirements at Special Periodical Surveys (1 July 2006)
Tankers ESP (Oil Carriers and Oil Carrier Features of Combination Carriers – Double Hull)
and Oil/Fuel Oil Tank Barges – Double Hull 122 meters (400 feet) and over in Length

[See also 7-3-2/5.14.5 and 7-3-2/5.5.1(f)iii]

<i>(a) Special Periodical Survey No. 1 (Age ≤ 5 Years) (1 July 2006)</i>	<i>(b) Special Periodical Survey No. 2 (5 < Age ≤ 10 Years) (1 July 2006)</i>	<i>(c) Special Periodical Survey No. 3 (10 < Age ≤ 15 Years) (1 July 2006)</i>	<i>(d) Special Periodical Survey No. 4 and Subsequent (Age > 15 Years) (1 July 2006)</i>
			<i>ix) Measurements, for general assessment and recording of corrosion patterns, of structural members subject to Close-up Survey.</i>

Note: In the case of oil tankers of 130 meters (427 feet) in length and upwards, for the evaluation of the vessel's longitudinal strength as required in 7-3-2/15.1.2, the sampling method of thickness measurements is given in 7-A-4/33..

TABLE 11
Minimum Requirements for CLOSE-UP Examination at Special Periodical Surveys (1 July 2016)
Tankers ESP (Oil Carriers and Oil Carrier Features of Combination Carriers – Double Hull)
and Oil/Fuel Oil Tank Barges – Double Hull 122 meters (400 feet) and over in Length
[See also 7-3-2/5.14.4 and 7-3-2/5.5.1(e)]

(a) <i>Special Periodical Survey No. 1 (Age ≤ 5 Years)</i>	(b) <i>Special Periodical Survey No. 2 (5 < Age ≤ 10 Years)</i>	(c) <i>Special Periodical Survey No. 3 (10 < Age ≤ 15 Years)</i>	(d) <i>Special Periodical Survey No. 4 and Subsequent (Age > 15 Years)</i>
<p>i) (1 July 2006) One (1) web frame⁽¹⁾ in one (1) ballast tank⁽²⁾. (See 7-A-13/Figure 4 Area 1.)</p> <p>ii) (1 July 2006) One (1) deck transverse⁽³⁾ in a cargo tank (See 7-A-13/Figure 4 Area 2.)</p> <p>iii) (1 July 2006) One (1) transverse bulkhead⁽⁴⁾ in one (1) ballast tank⁽²⁾. (See 7-A-13/Figure 4 Area 4.)</p> <p>iv) (1 July 2006) Lower part of a transverse bulkhead⁽⁵⁾ in one (1) cargo center tank⁽⁶⁾. (See 7-A-13/ Figure 4 Area 5.)</p> <p>v) (1 July 2006) Lower part of a transverse bulkhead⁽⁵⁾ in one (1) cargo wing tank. (See 7-A-13/ Figure 4 Area 5.)</p>	<p>i) (1 July 2006) All web frames⁽¹⁾ in one (1) ballast tank⁽²⁾. (See 7-A-13/Figure 4 Area 1.)</p> <p>ii) (1 July 2006) The knuckle area and the upper part (5 meters approximately)⁽⁷⁾ of one (1) web frame in each remaining ballast tank. (See 7-A-13/Figure 5 Area 6.)</p> <p>iii) (1 July 2006) One (1) deck transverse⁽³⁾ in two (2) cargo tanks. (See 7-A-13/Figure 4 Area 2.)</p> <p>iv) (1 July 2006) One (1) transverse bulkhead⁽⁴⁾ in all ballast tanks. (See 7-A-13/Figure 4 Area 4.)</p> <p>v) (1 July 2006) Lower part of a transverse bulkhead⁽⁵⁾ in two (2) cargo center tanks⁽⁶⁾. (See 7-A-13/ Figure 4 Area 5.)</p> <p>vi) (1 July 2006) Lower part of a transverse bulkhead⁽⁵⁾ in one (1) cargo wing tank. (See 7-A-13/ Figure 4 Area 5.)</p>	<p>i) (1 July 2006) All web frames⁽¹⁾ in all ballast tanks. (See 7-A-13/Figure 4 Area 1.)</p> <p>ii) (1 July 2006) All web frames⁽⁸⁾ in one (1) cargo tank. (See 7-A-13/Figure 5 Area 7.)</p> <p>iii) (1 July 2006) One (1) web frame⁽⁸⁾ in each remaining cargo tank. (See 7-A-13/Figure 5 Area 7.)</p> <p>iv) (1 July 2006) All transverse bulkheads⁽⁹⁾ in all cargo tanks. (See 7-A-13/Figure 4 Area 3.)</p> <p>v) (1 July 2006) All transverse bulkheads⁽⁴⁾ in all ballast tanks. (See 7-A-13/Figure 4 Area 4.)</p>	<p>i) (1 July 2006) All web frames⁽¹⁾ in all ballast tanks. (See 7-A-13/Figure 4 Area 1.)</p> <p>ii) (1 July 2006) All web frames⁽⁸⁾ in one (1) cargo tank. (See 7-A-13/Figure 5 Area 7.)</p> <p>iii) (1 July 2006) One (1) web frame⁽⁸⁾ in each remaining cargo tank. (See 7-A-13/Figure 5 Area 7.)</p> <p>iv) All transverse bulkheads⁽⁹⁾ in all cargo tanks. (See 7-A-13/Figure 4 Area 3.)</p> <p>v) (1 July 2006) All transverse bulkheads⁽⁴⁾ in all ballast tanks. (See 7-A-13/Figure 4 Area 4.)</p> <p>vi) Additional transverse areas as deemed necessary by the Surveyor.</p>

TABLE 11 (continued)
Minimum Requirements for CLOSE-UP Examination at Special Periodical Surveys (1 July 2016)
Tankers ESP (Oil Carriers and Oil Carrier Features of Combination Carriers – Double Hull)
and Oil/Fuel Oil Tank Barges – Double Hull 122 meters (400 feet) and over in Length
[See also 7-3-2/5.14.4 and 7-3-2/5.5.1(e)]

Notes:

- 1 Web frame in a ballast tank means vertical web in side tank, hopper web in hopper tank, floor in double bottom tank and deck transverse in double deck tank where fitted, including adjacent structural members. In fore and aft peak tanks, web frame means a complete transverse web frame ring including adjacent structural members.
- 2 A ballast tank means double bottom tank plus double side tank plus double deck tank, as applicable, even if these tanks are separate.
- 3 Deck transverse includes adjacent deck structural members or external structure on deck in way of the tank, where applicable.
- 4 Transverse bulkhead in a ballast tank includes girder system and adjacent structural members such as longitudinal bulkheads, girders in double bottom tanks, inner bottom plating, hopper side, inner hull longitudinal bulkhead and connecting brackets.
- 5 Transverse bulkhead lower part in a cargo tank includes girder system, adjacent structural members such as longitudinal bulkheads, and internal structure of lower stool, where fitted.
- 6 Where no center cargo tanks are fitted (as in the case of center longitudinal bulkhead), transverse bulkheads in port and starboard cargo wing tanks are to be surveyed.
- 7 Knuckle area is the area of the web frame around the connections of the slope hopper plating to the inner hull bulkhead and the inner bottom plating, up to 2 meters from the corners both on the bulkhead and the double bottom. The knuckle area and the upper part (5 meters approximately) include adjacent structural members.
- 8 (1 July 2016) Web frame in a cargo tank means deck transverse, longitudinal bulkhead structural elements and cross ties, where fitted, including adjacent structural members.
- 9 Transverse bulkhead in a cargo tank includes girder system, adjacent structural members such as longitudinal bulkheads, and internal structure of lower and upper stools, where fitted.

TABLE 12
Thickness Measurement Requirements at Special Periodical Surveys (1 July 2006)
General Dry Cargo Vessels (ESDC)
[See also 7-3-2/5.15.5]

<i>(a) Special Periodical Survey No. 1 (Age ≤ 5 Years)</i>	<i>(b) Special Periodical Survey No. 2 (5 < Age ≤ 10 Years)</i>	<i>(c) Special Periodical Survey No. 3 (10 < Age ≤ 15 Years) (1 July 2006)</i>	<i>(d) Special Periodical Survey No. 4 and Subsequent (Age > 15 Years) (1 July 2006)</i>
<p><i>i) Suspect areas.</i></p>	<p><i>i) Suspect areas.</i> <i>ii) (1 July 2006) One (1) transverse section of deck plating in way of a cargo space hatch opening (i.e., outside of cargo hatch opening) within the amidships 0.5L.</i> <i>iii) Measurement for general assessment and recording of corrosion pattern of those structural members subject to Close-up Survey.</i></p>	<p><i>i) Suspect areas.</i> <i>ii) (1 July 2006) Within the cargo length area, each deck plate outside line of cargo hatch openings.</i> <i>iii) Two (2) transverse sections within the amidships 0.5L in way of two (2) different cargo spaces.</i> <i>iv) All wind and water strakes within the cargo length area.</i> <i>v) Selected wind and water strakes outside the cargo length area.</i> <i>vi) All cargo hold hatch covers and coamings (plating and stiffeners).</i> <i>vii) Internals in forepeak and afterpeak tanks, including plating and stiffeners of forepeak and afterpeak tank bulkheads.</i> <i>viii) Measurement for general assessment and recording of corrosion pattern of those structural members subject to Close-up Survey.</i></p>	<p><i>i) Suspect areas.</i> <i>ii) (1 July 2006) Each deck plate outside line of cargo hatch openings within the cargo length area, all exposed main deck plates full length and all exposed first-tier superstructure deck plates (poop, bridge and forecastle decks).</i> <i>iii) A minimum of three transverse sections in way of cargo spaces within the amidships 0.5L.</i> <i>iv) All wind and water strakes full length port and starboard.</i> <i>v) All cargo hold hatch covers and coamings (plating and stiffeners).</i> <i>vi) Lowest strakes and strakes in way of tween decks of all transverse bulkheads in cargo space together with internals in way.</i> <i>vii) Internals in forepeak and afterpeak tanks, including plating and stiffeners of forepeak and afterpeak tank bulkheads.</i> <i>viii) Duct keel or pipe tunnel plating and internals.</i> <i>ix) (1 July 2006) Each bottom plate including lower turn of bilge within the cargo length area, all keel plates full length and also additional bottom plates in way of cofferdams, machinery space and aft end of tanks.</i></p>

TABLE 12 (continued)
Thickness Measurement Requirements at Special Periodical Surveys (1 July 2006)
General Dry Cargo Vessels (ESDC)
[See also 7-3-2/5.15.5]

(a) <i>Special Periodical Survey No. 1 (Age ≤ 5 Years)</i>	(b) <i>Special Periodical Survey No. 2 (5 < Age ≤ 10 Years)</i>	(c) <i>Special Periodical Survey No. 3 (10 < Age ≤ 15 Years) (1 July 2006)</i>	(d) <i>Special Periodical Survey No. 4 and Subsequent (Age > 15 Years) (1 July 2006)</i>
			x) Plating of seachests. Shell plating in way of overboard discharges as considered necessary by the attending Surveyor. xi) Measurement for general assessment and recording of corrosion pattern of those structural members subject to close-up survey.

TABLE 13
Minimum Requirements for CLOSE-UP Examination at Special Periodical Surveys (1 July 2006)
General Dry Cargo Vessels (ESDC)
[See also 7-3-2/5.15.4]

(a) <i>Special Periodical Survey No. 1 (Age ≤ 5 Years)</i>	(b) <i>Special Periodical Survey No. 2 (5 < Age ≤ 10 Years)</i>	(c) <i>Special Periodical Survey No. 3 (10 < Age ≤ 15 Years)</i>	(d) <i>Special Periodical Survey No. 4 and Subsequent (Age > 15 Years)</i>
<p>i) Selected transverse shell frames in one (1) forward and one (1) aft cargo hold and associated tween deck spaces. (See 7-A-6/Figure 4 Area A)</p> <p>ii) One (1) selected cargo hold transverse bulkhead, including plating, stiffeners and girders. (See 7-A-6/Figure 4 Area B)</p> <p>iii) All cargo hold hatch covers and coamings (plating and stiffeners) (See 7-A-6/Figure 4 Area D).</p>	<p>i) Selected transverse shell frames in all cargo holds and tween deck spaces. (See 7-A-6/Figure 4 Area A)</p> <p>ii) One (1) transverse bulkhead in each cargo hold, including bulkhead plating, stiffeners and girders. (See 7-A-6/Figure 4 Area B)</p> <p>iii) Forward and aft transverse bulkhead in one (1) side ballast tank, including stiffening system. (See 7-A-6/Figure 4 Area B)</p> <p>iv) (1 July 2006) One (1) transverse web with associated plating and framing in two (2) representative ballast tanks of each type (i.e., topside, hopper side, side tank or double bottom tank). (See 7-A-6/Figure 4 Area C)</p> <p>v) All cargo hold hatch covers and coamings (plating and stiffeners). (See 7-A-6/Figure 4 Area D)</p> <p>vi) (1 July 2006) Selected areas of all deck plating and underdeck structure inside line of hatch openings between cargo hold hatches. (See 7-A-6/Figure 4 Area E)</p> <p>vii) Selected areas of inner bottom plating. (See 7-A-6/Figure 4 Area F)</p>	<p>i) All transverse shell frames in the forward lower cargo hold and 25% frames in each of the remaining cargo holds and tween deck spaces, including upper and lower end attachments and adjacent shell plating. (See 7-A-6/Figure 4 Area A)</p> <p>ii) All cargo hold transverse bulkheads, including bulkhead plating, stiffeners and girders. (See 7-A-6/Figure 4 Area B)</p> <p>iii) All transverse bulkheads in ballast tanks, including stiffening system. (See 7-A-6/Figure 4 Area B)</p> <p>iv) (1 July 2006) All transverse webs with associated plating and framing in all ballast tanks. (See 7-A-6/Figure 4 Area C)</p> <p>v) All cargo hold hatch covers and coamings (plating and stiffeners). (See 7-A-6/Figure 4 Area D)</p> <p>vi) (1 July 2006) All deck plating and underdeck structure inside line of hatch openings between cargo hold hatches. (See 7-A-6/Figure 4 Area E)</p> <p>vii) All areas of inner bottom plating. (See 7-A-6/Figure 4 Area F)</p>	<p>i) All transverse shell frames in all cargo holds and tween deck spaces, including upper and lower end attachments and adjacent shell plating. (See 7-A-6/Figure 4 Area A)</p> <p>ii) All cargo hold transverse bulkheads, including bulkhead plating, stiffeners and girders. (See 7-A-6/Figure 4 Area B)</p> <p>iii) All transverse bulkheads in ballast tanks, including stiffening system. (See 7-A-6/Figure 4 Area B)</p> <p>iv) (1 July 2006) All transverse webs with associated plating and framing in all ballast tanks. (See 7-A-6/Figure 4 Area C)</p> <p>v) All cargo hold hatch covers and coamings (plating and stiffeners). (See 7-A-6/Figure 4 Area D)</p> <p>vi) (1 July 2006) All deck plating and underdeck structure inside line of hatch openings between cargo hold hatches. (See 7-A-6/Figure 4 Area E)</p> <p>vii) All areas of inner bottom plating. (See 7-A-6/Figure 4 Area F)</p>

TABLE 14
Thickness Measurement Requirements at Special Periodical Surveys (1 July 2008)
Bulk Carriers – Double Skin ESP and Bulk Carrier Features of Combination Carriers – Double Skin ESP
 [See also 7-3-2/5.19.5]

(a) Special Periodical Survey No. 1 (Age ≤ 5 Years)	(b) Special Periodical Survey No. 2 (5 < Age ≤ 10 Years)	(c) Special Periodical Survey No. 3 (10 < Age ≤ 15 Years) (1 July 2006)	(d) Special Periodical Survey No. 4 and Subsequent (Age > 15 Years) (1 July 2006)
i) Suspect areas throughout the vessel. ii) (1 July 2006) Measurement, for general assessment and recording of corrosion patterns, of structural members subject to close-up survey.	i) Suspect areas throughout the vessel. ii) (1 July 2006) Two (2) transverse sections of deck plating outside the line of cargo hatch openings within the cargo length area. iii) (1 July 2006) Plates in wind-and-water strakes in way of the two (2) transverse sections considered above. iv) (1 July 2008) Selected wind-and-water strake plating outside the cargo length area. v) Measurement, for general assessment and recording of corrosion patterns, of structural members subject to Close-up Survey.	i) Suspect areas throughout the vessel. ii) Each deck plate outside line of cargo hatch openings within the cargo length area. iii) (1 July 2006) Two (2) transverse sections, one (1) in the amidships area, outside the line of cargo hatch openings within the cargo length area. iv) All plating in two (2) wind-and-water strakes, port and starboard, within the cargo length area. v) Selected wind-and-water strake plating, outside the cargo length area. vi) All cargo hold hatch covers and coamings (plating and stiffeners). vii) (1 July 2006) Internals in forepeak and afterpeak tanks including plating and stiffeners of bulkheads. viii) Measurement, for general assessment and recording of corrosion pattern, of structural members subject to Close-up Survey.	i) Suspect areas throughout the vessel. ii) All exposed main deck plates full length and all exposed first-tier superstructure deck plates (poop, bridge and forecastle decks). iii) (1 July 2006) Three (3) transverse sections, one (1) in the amidships area, outside the line of cargo hatch openings within the cargo length area. iv) (1 July 2006) All plating in two (2) wind-and-water strakes, port and starboard, full length. v) All cargo hold hatch covers and coamings (plating and stiffeners). vi) Internals in forepeak and afterpeak tanks, including plating and stiffeners of forepeak and afterpeak tank bulkheads. vii) (1 July 2006) Duct keel or pipe tunnel plating and internals. viii) (1 July 2006) Each bottom plate, including lower turn of bilge within the cargo length area, all keel plates full length and also additional bottom plates in way of cofferdams, machinery space and aft end of tanks.

TABLE 14 (continued)
Thickness Measurement Requirements at Special Periodical Surveys (1 July 2008)
Bulk Carriers – Double Skin ESP and Bulk Carrier Features of Combination Carriers – Double Skin ESP
[See also 7-3-2/5.19.5]

<i>(a) Special Periodical Survey No. 1 (Age ≤ 5 Years)</i>	<i>(b) Special Periodical Survey No. 2 (5 < Age ≤ 10 Years)</i>	<i>(c) Special Periodical Survey No. 3 (10 < Age ≤ 15 Years) (1 July 2006)</i>	<i>(d) Special Periodical Survey No. 4 and Subsequent (Age > 15 Years) (1 July 2006)</i>
			<ul style="list-style-type: none"> <li data-bbox="1556 486 2004 598"><i>ix)</i> Plating of sea chests. Shell plating in way of overboard discharges as considered necessary by the attending Surveyor. <li data-bbox="1556 606 2004 742"><i>x)</i> Measurement, for general assessment and recording of corrosion patterns of structural members subject to Close-up Survey.

TABLE 15
Minimum Requirements for CLOSE-UP Examination at Special Periodical Surveys (1 July 2016)
Bulk Carriers – Double Skin ESP and Bulk Carrier Features of Combination Carriers – Double Skin ESP
[See also 7-3-2/5.19.4]

<i>(a) Special Periodical Survey No. 1 (Age ≤ 5 Years)</i>	<i>(b) Special Periodical Survey No. 2 (5 < Age ≤ 10 Years)</i>	<i>(c) Special Periodical Survey No. 3 (10 < Age ≤ 15 Years)</i>	<i>(d) Special Periodical Survey No. 4 and Subsequent (Age > 15 Years)</i>
<p><i>i) (1 July 2006) One (1) transverse web frame⁽¹⁾ in two (2) representative ballast tanks of each type in topside, hopper side and double side ballast tanks. (This is to include the foremost topside and double side ballast tanks on either side) (See 7-A-15/Figure 1 Area A.)</i></p> <p><i>ii) (1 July 2006) Two (2) selected cargo hold transverse bulkheads⁽²⁾. (See 7-A-15/Figure 1 Area C.)</i></p> <p><i>iii) (1 July 2016) All cargo hold hatch covers and coamings⁽³⁾ (plating and stiffeners). (See 7-A-15/Figure 1 Area D)</i></p>	<p><i>i) (1 July 2006) One (1) transverse web frame⁽¹⁾ in all ballast tanks. (See 7-A-15/Figure 1 Area A.)</i></p> <p><i>ii) Forward and aft transverse bulkheads, including stiffening systems in a transverse section including topside, hopper side and double side ballast tanks on one side of the ship (i.e., port or starboard). (See 7-A-15/Figure 1 Area A)</i></p> <p><i>iii) (1 July 2016) 25% of ordinary transverse frames for transverse framing system or 25% of longitudinals for longitudinal framing system on side shell and inner side plating at forward, middle and aft parts, in the foremost double side ballast tanks (See 7-A-15/Figure 2 Area B.)</i></p> <p><i>iv) (1 July 2006) One (1) transverse bulkhead⁽²⁾ in all cargo holds. (See 7-A-15/Figure 1 Area C.)</i></p> <p><i>v) (1 July 2016) All cargo hold hatch covers and coamings⁽³⁾ (plating and stiffeners). (See 7-A-15/Figure 1 Area D.)</i></p> <p><i>vi) All deck plating and under deck structure inside line of hatch openings between all cargo hold hatches. (See 7-A-15/Figure 1 Area E)</i></p>	<p><i>i) (1 July 2006) All transverse web frames⁽¹⁾ in all ballast tanks. (See 7-A-15/Figure 1 Area A.)</i></p> <p><i>ii) (1 July 2006) All transverse bulkheads, including stiffening systems in all ballast tanks. (See 7-A-15/Figure 1 Area A.)</i></p> <p><i>iii) (1 July 2016) 25% of ordinary transverse frames for transverse framing system or 25% of longitudinals for longitudinal framing system on side shell and inner side plating at forward, middle and aft parts, in all double side ballast tanks (See 7-A-15/Figure 2 Area B.)</i></p> <p><i>iv) (1 July 2016) All cargo hold transverse bulkheads⁽²⁾. (See 7-A-15/Figure 1 Area C.)</i></p> <p><i>v) (1 July 2006) All cargo hatch covers and coamings⁽³⁾ (plating and stiffeners). (See 7-A-15/Figure 1 Area D.)</i></p> <p><i>vi) All deck plating and under deck structure inside line of hatch openings between all cargo hold hatches. (See 7-A-15/Figure 1 Area E)</i></p>	<p><i>i) (1 July 2006) All transverse web frames⁽¹⁾ in all ballast tanks. (See 7-A-15/Figure 1 Area A.)</i></p> <p><i>ii) (1 July 2006) All transverse bulkheads, including stiffening systems in all ballast tanks. (See 7-A-15/Figure 1 Area A.)</i></p> <p><i>iii) (1 July 2016) All ordinary transverse frames for transverse framing system or 25% of longitudinals for longitudinal framing system on side shell and inner side plating at forward, middle and aft parts, in all double side ballast tanks (See 7-A-15/Figure 2 Area B.)</i></p> <p><i>iv) (1 July 2006) All cargo hold transverse bulkheads⁽²⁾. (See 7-A-15/Figure 1 Area C.)</i></p> <p><i>v) (1 July 2016) All cargo hatch covers and coamings⁽³⁾ (plating and stiffeners). (See 7-A-15/Figure 1 Area D.)</i></p> <p><i>vi) All deck plating and under deck structure inside line of hatch openings between all cargo hold hatches. (See 7-A-15/Figure 1 Area E)</i></p>

TABLE 15 (continued)
Minimum Requirements for CLOSE-UP Examination at Special Periodical Surveys (1 July 2016)
Bulk Carriers – Double Skin ESP and Bulk Carrier Features of Combination Carriers – Double Skin ESP
[See also 7-3-2/5.19.4]

Notes:

- 1 Transverse web frame includes associated plating, stiffeners and longitudinals.
In fore and aft peak tanks, transverse web frame means a complete transverse web frame ring, including adjacent structural members.
- 2 Cargo hold transverse bulkhead includes plating, stiffeners and girders, and internal structure of upper and lower stools, where fitted.
- 3 (1 July 2016) Cargo hold covers and coamings. Subject to cargo hold hatch covers of approved design which structurally have no access to the internals, close-up survey/thickness measurement shall be done of accessible parts of hatch covers structures.

TABLE 16
Thickness Measurement Requirements at Special Periodical Surveys (1 July 2006)
Chemical Carriers ESP
[See also 7-3-2/5.21.5]

<i>(a) Special Periodical Survey No. 1 (Age ≤ 5 Years)</i>	<i>(b) Special Periodical Survey No. 2 (5 < Age ≤ 10 Years)</i>	<i>(c) Special Periodical Survey No. 3 (10 < Age ≤ 15 Years)</i>	<i>(d) Special Periodical Survey No. 4 and Subsequent (Age > 15 Years)</i>
<ul style="list-style-type: none"> <i>i)</i> Suspect areas throughout the vessel. <i>ii)</i> One (1) transverse section of deck plating for the full beam of the ship within the cargo area, in way of a ballast tank, if any. <i>iii)</i> Measurements, for general assessment and recording of corrosion patterns, of those structural members subject to Close-up Survey. 	<ul style="list-style-type: none"> <i>i)</i> Suspect areas throughout the vessel. <i>ii)</i> All main deck plating within the cargo area. <i>iii)</i> One (1) transverse section within the cargo area. <i>iv)</i> Selected wind-and-water strakes outside the cargo area. <i>v)</i> Internals in forepeak and afterpeak tanks including plating and stiffeners of bulkheads. <i>vi)</i> Measurements, for general assessment and recording of corrosion patterns, of those structural members subject to Close-up Survey. 	<ul style="list-style-type: none"> <i>i)</i> Suspect areas throughout the vessel. <i>ii)</i> All main deck plating within the cargo area. <i>iii)</i> Two (2) transverse sections within the cargo area, including at least one (1) section in way of a ballast tank within amidships 0.5L. <i>iv)</i> All wind-and-water strakes within the cargo area, and selected wind-and-water strakes outside the cargo area. <i>v)</i> Internals in forepeak and afterpeak tanks including plating and stiffeners of bulkheads. <i>vi)</i> Measurements, for general assessment and recording of corrosion patterns, of those structural members subject to Close-up Survey. 	<ul style="list-style-type: none"> <i>i)</i> Suspect areas throughout the vessel. <i>ii)</i> All main deck plating within the cargo area, all exposed main deck plating outside the cargo area and all exposed first tier superstructure deck plating (poop, bridge and forecastle decks). <i>iii)</i> A minimum of three (3) transverse sections within the cargo area, including at least one (1) section in way of a ballast tank within amidships 0.5L. <i>iv)</i> All wind-and-water strakes, full length. <i>v)</i> Internals in forepeak and afterpeak tanks including plating and stiffeners of bulkheads. <i>vi)</i> Duct keel or pipe tunnel plating and internals. <i>vii)</i> All keel plates full length. All bottom plates within the cargo area, also additional bottom plates in way of cofferdams, machinery space and aft end of tanks. <i>viii)</i> Plating of seachests. Shell plating in way of overboard discharges as considered necessary by the attending Surveyor. <i>ix)</i> Measurements, for general assessment and recording of corrosion patterns, of those structural members subject to Close-up Survey.

TABLE 17
Minimum Requirements for CLOSE-UP Examination at Special Periodical Surveys (1 July 2013)
Single Hull Chemical Carriers ESP
[See also 7-3-2/5.21.4(b)]

i) <i>Special Periodical Survey No. 1 (Age ≤ 5 Years)</i>	ii) <i>Special Periodical Survey No. 2 (5 < Age ≤ 10 Years)</i>	iii) <i>Special Periodical Survey No. 3 (10 < Age ≤ 15 Years)</i>	iv) <i>Special Periodical Survey No. 4 and Subsequent (Age > 15 Years)</i>
<ul style="list-style-type: none"> ● One (1) complete transverse web frame ring including adjacent structural members in a ballast wing tank. (See 7-A-7/Figure 9 Area A) ● One (1) deck transverse including adjacent structural members in a cargo tank or on deck. (See 7-A-7/Figure 9 Area B) ● Lower part of one (1) transverse bulkhead, including girder system and adjacent structural members in: <ul style="list-style-type: none"> - One (1) ballast tank - One (1) cargo wing tank - One (1) cargo center tank⁽²⁾ (See 7-A-7/Figure 9 Area D) 	<ul style="list-style-type: none"> ● All plating and internal structure including all tank boundaries and internal structure and external structure on deck in way of all web frame rings in a ballast wing tank or double bottom ballast tank⁽¹⁾. (See 7-A-7/Figure 9 Area A) ● One (1) deck transverse including adjacent deck structural members in: <ul style="list-style-type: none"> - Each remaining ballast tank or on deck - One (1) cargo wing tank or on deck - Two (2) cargo center tanks or on deck (See 7-A-7/Figure 9 Area B) ● Both transverse bulkheads including girder system and adjacent structural members in a ballast wing tank. (See 7-A-7/Figure 9 Area C) 	<ul style="list-style-type: none"> ● All plating and internal structure including all tank boundaries and internal structure and external structure on deck in way of all web frame rings in all ballast tanks. (See 7-A-7/Figure 9 Area C, E) ● All plating and internal structure including all tank boundaries and internal structure and external structure on deck in way of all web frame rings in a cargo wing tank. (See 7-A-7/Figure 9 Area E) ● One (1) complete transverse web frame ring including adjacent structural members in each remaining cargo tank. (See 7-A-7/Figure 9 Area A) ● All transverse bulkheads including girder system and adjacent structural members in all cargo tanks. (See 7-A-7/Figure 9 Area C) ● All transverse bulkheads including girder system and adjacent structural members in all ballast tanks. (See 7-A-7/Figure 9 Area C) 	<ul style="list-style-type: none"> ● All plating and internal structure including all tank boundaries and internal structure and external structure on deck in way of all web frame rings in all ballast tanks. (See 7-A-7/Figure 9 Area C, E) ● All plating and internal structure including all tank boundaries and internal structure and external structure on deck in way of all web frame rings in a cargo wing tank. (See 7-A-7/Figure 9 Area E) ● One (1) complete transverse web frame ring including adjacent structural members in each remaining cargo tank. (See 7-A-7/Figure 9 Area A) ● All transverse bulkheads including girder system and adjacent structural members in all cargo tanks. (See 7-A-7/Figure 9 Area C) ● All transverse bulkheads including girder system and adjacent structural members in all ballast tanks. (See 7-A-7/Figure 9 Area C)

TABLE 17 (continued)
Minimum Requirements for CLOSE-UP Examination at Special Periodical Surveys (1 July 2013)
Single Hull Chemical Carriers ESP
[See also 7-3-2/5.21.4(b)]

i) Special Periodical Survey No. 1 (Age ≤ 5 Years)	ii) Special Periodical Survey No. 2 (5 < Age ≤ 10 Years)	iii) Special Periodical Survey No. 3 (10 < Age ≤ 15 Years)	iv) Special Periodical Survey No. 4 and Subsequent (Age > 15 Years)
	<ul style="list-style-type: none"> • Lower part of one (1) transverse bulkhead including girder system and adjacent structural members in: <ul style="list-style-type: none"> - Each remaining ballast tank - One (1) cargo wing tank - Two (2) cargo center tanks⁽²⁾ (See 7-A-7/Figure 9 Area D) 		<ul style="list-style-type: none"> • Any additional tanks and structure as considered necessary by the Surveyor.

Notes:

- 1 Ballast double hull tank: means double bottom tank plus double side tank plus double deck tank, as applicable, even if these tanks are separate.
- 2 Where no center tanks are fitted (as in the case of center longitudinal bulkhead), transverse bulkheads in wing tanks are to be surveyed.

TABLE 18
Minimum Requirements for CLOSE-UP Examination at Special Periodical Surveys (1 July 2008)
Ore Carriers
[See also 7-3-2/5.19.4]

(a) <i>Special Periodical Survey No. 1 (Age ≤ 5 Years)</i>	(b) <i>Special Periodical Survey No. 2 (5 < Age ≤ 10 Years)</i>	(c) <i>Special Periodical Survey No. 3 (10 < Age ≤ 15 Years)</i>	(d) <i>Special Periodical Survey No. 4 and Subsequent (Age > 15 Years)</i>
<p>i) One (1) complete transverse web frame ring including adjacent structural members in a ballast wing tank. (See 7-A-15/Figure 6 Area A)</p> <p>ii) One (1) transverse bulkhead lower part, including girder system and adjacent structural members in a ballast tank. (See 7-A-15/Figure 6 Area D)</p> <p>iii) Two (2) selected cargo hold transverse bulkheads, including internal structure of upper and lower stools, where fitted. (See 7-A-15/Figure 6 Area C)</p> <p>iv) All cargo hold hatch covers and coamings (plating and stiffeners). (See 7-A-15/Figure 1 Area D)</p>	<p>i) All complete transverse web frame rings including adjacent structural members in a ballast wing tank. (See 7-A-15/Figure 6 Area A)</p> <p>ii) One (1) deck transverse including adjacent deck structural members in each remaining ballast tank. (See 7-A-15/Figure 6 Area B)</p> <p>iii) Forward and aft transverse bulkheads, including girder system and adjacent structural members in a ballast tank. (See 7-A-15/Figure 6 Area C)</p> <p>iv) One (1) transverse bulkhead lower part, including girder system and adjacent structural members in each remaining ballast tank. (See 7-A-15/Figure 6 Area D)</p> <p>v) One (1) transverse bulkhead in each cargo hold, including internal structure of upper and lower stools, where fitted. (See 7-A-15/Figure 6 Area C)</p> <p>vi) All cargo hold hatch covers and coamings (plating and stiffeners). (See 7-A-15/Figure 1 Area D)</p> <p>vii) All deck plating and under deck structure inside line of hatch openings between all cargo hold hatches. (See 7-A-15/Figure 1 Area E)</p>	<p>i) All complete transverse web frame rings including adjacent structural members in each ballast tank. (See 7-A-15/Figure 6 Area A)</p> <p>ii) All transverse bulkheads, including girder system and adjacent structural members in each ballast tank. (See 7-A-15/Figure 6 Area C)</p> <p>iii) One (1) complete web frame ring including adjacent structural members in each wing void space. (See 7-A-15/Figure 6 Area A.)</p> <p>iv) Additional web frame rings in void spaces as deemed necessary by the Surveyor.</p> <p>v) All cargo hold transverse bulkheads, including internal structure of upper and lower stools, where fitted. (See 7-A-15/Figure 6 Area C.)</p> <p>vi) All cargo hatch covers and coamings (plating and stiffeners). (See 7-A-15/Figure 1 Area D.)</p> <p>vii) All deck plating and under deck structure inside line of hatch openings between all cargo hold hatches. (See 7-A-15/Figure 1 Area E)</p>	<p>Same requirements as for Special Periodical Survey No. 3</p>

TABLE 19
Minimum Requirements for CLOSE-UP Examination at Special Periodical Surveys (1 July 2013)
Double Hull Chemical Carriers ESP
[See also 7-3-2/5.21.4(c)]

i) <i>Special Periodical Survey No. 1 (Age ≤ 5 Years)</i>	ii) <i>Special Periodical Survey No. 2 (5 < Age ≤ 10 Years)</i>	iii) <i>Special Periodical Survey No. 3 (10 < Age ≤ 15 Years)</i>	iv) <i>Special Periodical Survey No. 4 and Subsequent (Age > 15 Years)</i>
<ul style="list-style-type: none"> • One (1) complete transverse web frame ring including adjacent structural members in a ballast double hull tank^(1,3). (See 7-A-7/Figure 10 Area 1) • One (1) deck transverse including adjacent deck structural members (or external structure on deck in way of the tank, where applicable) in a cargo tank or on deck. (See 7-A-7/Figure 10 Area 2) • One (1) complete transverse bulkhead, including girder system and adjacent structural members, such as longitudinal bulkheads, girders in double bottom tanks, inner bottom plating, hopper side and connecting brackets in a ballast tank⁽¹⁾. See 7-A-7/Figure 11 Area 4) • Lower part of one (1) transverse bulkhead, including girder system, adjacent structural members (such as longitudinal bulkheads) and internal structure of lower stool, where fitted, in: <ul style="list-style-type: none"> - One (1) cargo wing tank - One (1) cargo center tank⁽²⁾ (See 7-A-7/Figure 11 Area 5) 	<ul style="list-style-type: none"> • All transverse web frame rings including adjacent structural members in a ballast wing tank or ballast double hull tank^(1,3). (See 7-A-7/Figure 10 Area 1) • The knuckle area and the upper part (3 meters approx.) of one web frame, including adjacent structural members, in each remaining ballast tank⁽⁴⁾. (See 7-A-7/Figure 12 Area 6) • One (1) deck transverse including adjacent deck structural members (or external structure on deck in way of the tank, where applicable) in two cargo tanks. (See 7-A-7/Figure 10 Area 2) • One (1) complete transverse bulkhead, including girder system and adjacent structural members, such as longitudinal bulkheads, girders in double bottom tanks, inner bottom plating, hopper side and connecting brackets in each ballast tank⁽¹⁾. (See 7-A-7/Figure 11 Area 4) 	<ul style="list-style-type: none"> • All transverse web frame rings including adjacent structural members in all ballast tanks⁽³⁾. (See 7-A-7/Figure 10 Area 1) • All transverse web frame rings, including deck transverse, longitudinal bulkhead vertical girder and cross ties, where fitted, and adjacent structural members, in a cargo wing tank. (See 7-A-7/Figure 12 Area 7) • One (1) transverse web frame ring, including deck transverse, longitudinal bulkhead vertical girder and cross ties, where fitted, and adjacent structural members, in each remaining cargo tank. (See 7-A-7/Figure 12 Area 7) • All complete transverse bulkheads, including girder system, adjacent structural members (such as longitudinal bulkheads) and internal structure of lower and upper stools, where fitted, in all cargo tanks. (See 7-A-7/Figure 11 Area 3) 	<ul style="list-style-type: none"> • All transverse web frame rings including adjacent structural members in all ballast tanks⁽³⁾. (See 7-A-7/Figure 10 Area 1) • All transverse web frame rings, including deck transverse, longitudinal bulkhead vertical girder and cross ties, where fitted, and adjacent structural members, in a cargo wing tank. (See 7-A-7/Figure 12 Area 7) • One (1) transverse web frame ring, including deck transverse, longitudinal bulkhead vertical girder and cross ties, where fitted, and adjacent structural members, in each remaining cargo tank. (See 7-A-7/Figure 12 Area 7) • All complete transverse bulkheads, including girder system, adjacent structural members (such as longitudinal bulkheads) and internal structure of lower and upper stools, where fitted, in all cargo tanks. (See 7-A-7/Figure 11 Area 3)

TABLE 19 (continued)
Minimum Requirements for CLOSE-UP Examination at Special Periodical Surveys (1 July 2013)
Double Hull Chemical Carriers ESP
[See also 7-3-2/5.21.4(c)]

i) <i>Special Periodical Survey No. 1 (Age ≤ 5 Years)</i>	ii) <i>Special Periodical Survey No. 2 (5 < Age ≤ 10 Years)</i>	iii) <i>Special Periodical Survey No. 3 (10 < Age ≤ 15 Years)</i>	iv) <i>Special Periodical Survey No. 4 and Subsequent (Age > 15 Years)</i>
	<ul style="list-style-type: none"> • Lower part of one (1) transverse bulkhead, including girder system, adjacent structural members (such as longitudinal bulkheads) and internal structure of lower stool, where fitted, in: <ul style="list-style-type: none"> - One (1) cargo wing tank - Two (2) cargo center tanks⁽²⁾ (See 7-A-7/Figure 11 Area 5) 	<ul style="list-style-type: none"> • All complete transverse bulkheads, including girder system and adjacent structural members, such as longitudinal bulkheads, girders in double bottom tanks, inner bottom plating, hopper side and connecting brackets in all ballast tanks. (See 7-A-7/Figure 11 Area 4) 	<ul style="list-style-type: none"> • All complete transverse bulkheads, including girder system and adjacent structural members, such as longitudinal bulkheads, girders in double bottom tanks, inner bottom plating, hopper side and connecting brackets in all ballast tanks. (See 7-A-7/Figure 11 Area 4) • Any additional tanks and structure as deemed necessary by the Surveyor.

Notes:

- 1 Ballast double hull tank: means double bottom tank plus double side tank plus double deck tank, as applicable, even if these tanks are separate.
- 2 Where no center tanks are fitted (as in the case of center longitudinal bulkhead), transverse bulkheads in wing tanks are to be surveyed.
- 3 Web frame in a ballast tank means vertical web in side tank, hopper web in hopper tank, floor in double bottom tank and deck transverse in double deck tank (where fitted). In fore and aft peak tanks web frame means a complete transverse web frame ring including adjacent structural members.
- 4 Knuckle area is the area of the web frame around the connections of the slope hopper plating to the inner hull bulkhead and the inner bottom plating, up to 2 meters from the corners both on the bulkhead and the double bottom.

PART

7

APPENDIX

SECTION 17 Survey of Portable Industrial Modules (2014)

1 General

Where a portable industrial module is installed, it is to be subjected to survey in presence of and to the satisfaction of the attending Surveyor.

Modular units may be used for various purposes, such as the following:

- Workshops
- Instrument Control/MCC/Battery/Switchgear Rooms
- Laboratories
- Wireline Units
- R.O.V. Control Room
- Mud Logging Cabins

3 Container Box used as an Industrial Module

Where a container box is considered acceptable as a portable modular unit in accordance with the applicable Rules for the intended purpose, the container is to be confirmed as being certified to a recognized standard.

A container box is to be properly secured to the deck. Means of securing other than welding may be accepted provided efficiency of tie downs are design reviewed by ABS.

3.1 Stacked Container Boxes used as Portable Modular Units

Stacked arrangements of container boxes as modular units require design review by ABS, and to be surveyed accordingly.

5 Survey of Portable Industrial Modules

Survey of a portable industrial module is to be carried out to verify satisfactory condition of the structure, piping, and electrical equipment. The following are to be confirmed:

- i)* The module is free of any physical damage that may affect its strength and effectiveness of its service.
- ii)* Material used for flooring, ceiling, linings, etc. that is included in the interior of the module is in compliance with a similar standard as that applied to the main accommodation spaces on the vessel.
- iii)* The module is secured onboard the deck by means of welding. Means of securing other than welding may be accepted provided efficiency of tie downs are design reviewed by ABS.
- iv)* Boundaries of the module are constructed (and insulated where necessary) of suitable material to withstand equal level of fire protection in the area where other service spaces are installed.
- v)* Access doors to and from the module rated to withstand equal level of fire protection as the module itself.
- vi)* The module is provided with suitable fire or smoke detection system.

- vii)* The module is provided with suitable number of general alarms bells. If the external alarms of the general alarm and public address system are audible from inside the module during normal operation of the vessel, installation of an internal system may be waived.
- viii)* If installed on a vessel carrying oil or noxious liquid substances, the portable industrial module is to be installed in a protected location aft of the cargo tanks or design reviewed by ABS. Ventilation inlet(s) and outlet(s) are located in non-hazardous areas and not facing the cargo area.
- ix)* Piping of the module is to be connected to the vessel's piping system(s), and cross-connections do not affect the safety of the vessel. Under no circumstances, are drain pipes of modules to be connected to any hazardous drain of the vessel.
- x)* The module is located to provide easy and protected access to all escape routes that lead to designated embarkation stations. The term "easy and protected" will be interpreted as routes that provide protection from falling objects; a walk path without any structural, mechanical or electrical obstruction; and efficiently illuminated with main and emergency power system.
- xi)* All connections and/or penetrations on the module for vessel supplied piping and/or electrical systems maintain the original integrity of the module, and these connections and/or penetrations are in compliance with a recognized standard.
- xii)* Where module is located on the open deck of a vessel and may be subjected to wave impact loading, efficiency of the quarter is design reviewed by ABS. Alternatively the module is to be unmanned during heavy weather and a notice indicating the same is to be affixed to the module.

7 Certification of Vessel Fitted with Portable Modular Units

The vessel's life-saving plan is to be amended to indicate installation and location of additional portable modular units. Surveyor is to endorse the onboard life-saving plan to indicate ABS verification.