



National Defence

National Defence Headquarters
Ottawa, Ontario
K1A 0K2

Défense nationale

Quartier général de la Défense nationale
Ottawa (Ontario)
K1A 0K2

REQUEST FOR PROPOSAL DEMANDE DE PROPOSITION

**AMENDMENT NO.
N° DE LA MODIFICATION**
003

**RETURN BIDS TO:
RETOURNER LES SOUMISSIONS À :**
Michelle.Brassard@forces.gc.ca

Proposal To: National Defence Canada

We hereby offer to sell to His Majesty the King in right of Canada, in accordance with the terms and conditions set out herein, referred to herein or attached hereto, the goods and services listed herein and on any attached sheets at the price(s) set out therefore.

Proposition à : Défense nationale Canada

Nous offrons par la présente de vendre à Sa Majesté le Roi du chef du Canada, aux conditions énoncées ou incluses par référence dans la présente et aux annexes ci-jointes, les biens et services énumérés ici et sur toute feuille ci-annexée, au(x) prix indiqué(s).

Title – Titre : Suspenders, Trousers / Bretelles, Pantalon	Solicitation No. – N° de l'invitation W8486-228228/A
Date of Amendment – Date de modification December 23, 2022 / décembre 23, 2022	
Address Enquiries to: – Adresser toutes questions à : Michelle Brassard by e-mail to michelle.brassard@forces.gc.ca	
Telephone No. – N° de telephone	FAX No. – N° de fax
Destination See Herein	

Instructions: Municipal taxes are not applicable. Unless otherwise specified herein all prices quoted must include all applicable Canadian customs duties, GST/HST, excise taxes and are to be delivered Delivery Duty Paid including all delivery charges to destination(s) as indicated. The amount of the Goods and Services Tax/Harmonized Sales Tax is to be shown as a separate item.

Instructions : Les taxes municipales ne s'appliquent pas. Sauf indication contraire, les prix indiqués doivent comprendre les droits de douane canadiens, la TPS/TVH et la taxe d'accise. Les biens doivent être livrés « rendu droits acquittés », tous frais de livraison compris, à la ou aux destinations indiquées. Le montant de la taxe sur les produits et services/taxe de vente harmonisée doit être indiqué séparément.

**Solicitation Closes –
L'invitation prend fin**

At: – à :

2:00 PM EST / HNE

On: – le :

February 16, 2023 / février 16, 2023

Delivery Required – Livraison exigée See herein.
Vendor Name and Address – Raison sociale et adresse du fournisseur [Bidder to insert]
Name and title of person authorized to sign on behalf of vendor (type or print) – Nom et titre de la personne autorisée à signer au nom du fournisseur (caractère d'imprimerie) [Bidder to insert]
Name – Nom _____ Title – Titre _____
Signature _____ Date _____

Amendment 003

- To extend the bid solicitation deadline from January 6, 2023 to February 16, 2023
- To answer questions regarding the solicitation

Questions and Responses:

DND has the following responses to questions submitted during the bid period:

<p>QUESTION 2 : We have a question regarding the shape of the triangle leather piece (DSSPM 2-6-87-197 Figure 2 Item B). The shape of the piece on the viewing sample is slightly different with round edges. Which shape is required? Do you have any pattern drawings?</p> <p>ANSWER 2: The edges on the leather polygon should be rounded as shown on sealed sample DCGEM 103-86. The shape of DSSPM 2-6-87-197 Figure 1 and Figure 2 Item B have been updated to show rounded edges.</p> <p>Technical drawings are available.</p> <p>DELETE: DSSPM 2-6-87-197 Figures 1 and 2 dated April 2020.</p> <p>INSERT: DSSPM 2-6-87-197 Figures 1 and 2 dated DEC 2022.</p>	<p>QUESTION 2 : Nous avons une question concernant la forme de la pièce de cuir triangulaire (DSSPM 2-6-87-197 Figure 2 Item B). La forme de la pièce sur l'échantillon visuel est quelque peu différente avec des bords arrondis. Quelle forme est requise ? Avez-vous des dessins de modèles?</p> <p>RÉPONSE 2 : Les bords du polygone de cuir doivent être arrondis comme indiqué sur le modèle approuvé DCGEM 103-86. La forme du DSSPM 2-6-87-197 figure 1 et figure 2, article B sont mise à jour pour montrer les bords arrondis.</p> <p>Des dessins techniques sont disponibles.</p> <p>SUPPRIMER : DSSPM 2-6-87-197 Figures 1 et 2 datées avril 2020.</p> <p>INSÉRER : DSSPM 2-6-87-197 Figures 1 et 2 datées DEC 2022.</p>
---	--

DELETE / SUPPRIMER:

DSSPM 2-6-87-197 April 2020

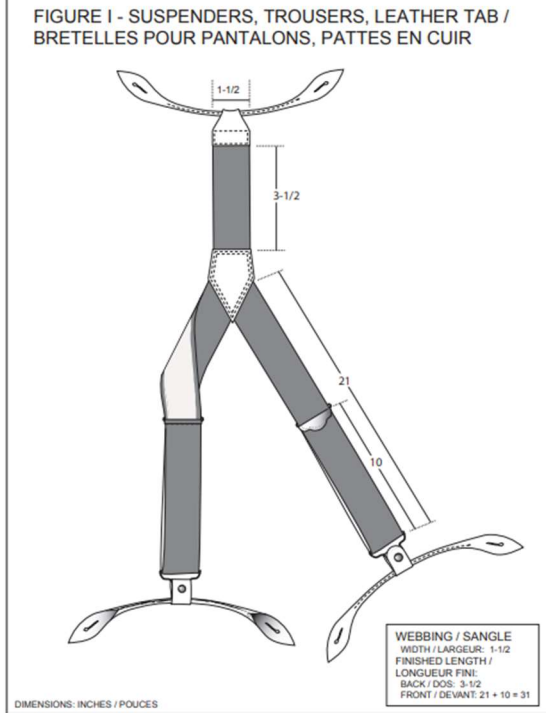

DSSPM 2-6-87-197 April 2020

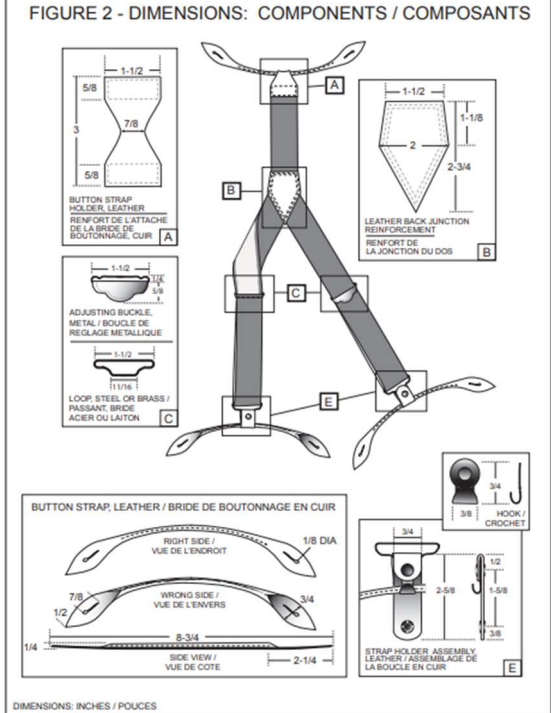

INSERT / INSÉRER:

DSSPM 2-6-87-197 - DEC 2022

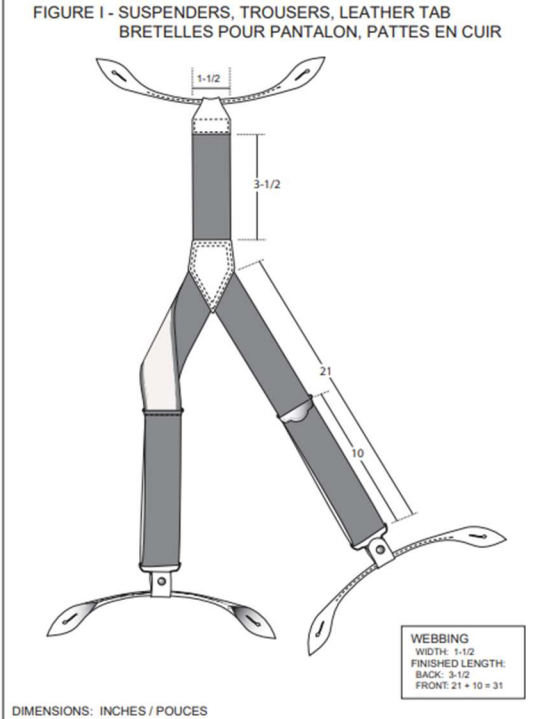

DSSPM 2-6-87-197 - DEC 2022

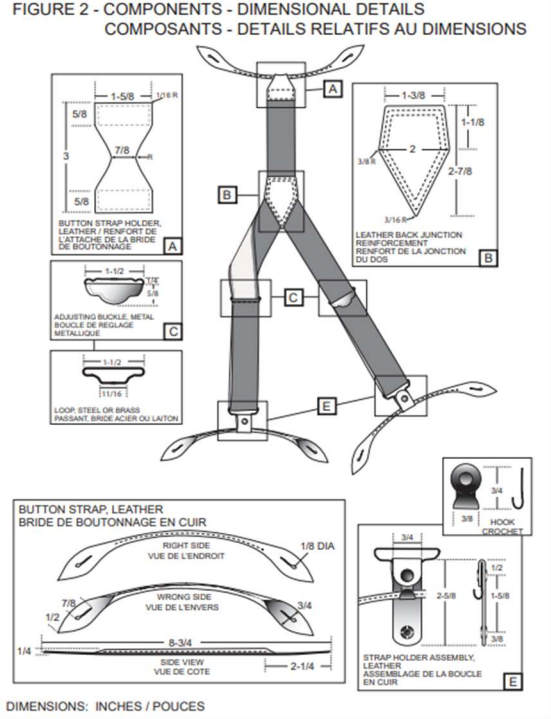

QUESTION 3.

1. Figure 2 - Dimensions, Diagram "C" - Bottom image; refers to a steel or brass wire frame loop. Can you please specify the "Gauge" of the metal for us, or please let us know where we can find this information.

2. Figure 2 - Dimensions, Diagram "E" ; illustrates the strap holder assembly.

Also;

In Annex B, 3.2.4.5 Socket-button, stud and eyelets. The dimensions must be in accordance with Sealed Pattern DCGEM 103-86.

Can you please let us know where the patterns specifically detailing the specs for the socket-button, stud and eyelets are located. We have the technical data package which includes a viewing sample and CD.

We would like to know what is the ligne number for the socket and cap, what is the post length dimension supposed to be? etc.

ANSWER 3:

The metal fittings listed in Section 3.2.4 must be in accordance with Sealed Pattern DCGEM 103-86. Technical drawings are available on request.

QUESTION 3.

1. Figure 2 - Dimensions, Schéma "C" - Image du bas ; fait référence à une bride de cadre en fil d'acier ou de laiton. Pouvez-vous s'il vous plaît spécifier la "jauge" du métal pour nous, ou s'il vous plaît laissez-nous savoir où nous pouvons trouver cette information.

2. Figure 2 - Dimensions, schéma "E" ; illustre l'assemblage de la boucle en cuir.

Aussi;

Dans l'annexe B, 3.2.4.5 Prise-bouton, goujon et œillets. Les dimensions doivent être conformes au modèle approuvé DCGEM 103-86.

Pouvez-vous s'il vous plaît nous faire savoir où se trouvent les modèles détaillant spécifiquement les spécifications du côté femelle et côté mâle du bouton-pression et œillets. Nous avons le dossier de données techniques qui comprend un échantillon visuel et un CD.

Nous aimerions savoir quel est le numéro de ligne pour le bouton pression, quelle est la dimension de la longueur du poteau censée être? etc.

RÉPONSE 3 :

Les pièces métalliques énumérés à l'article 3.2.4 doivent être conformes au modèle approuvé DCGEM 103-86. Les dessins techniques sont disponibles sur demande.

QTY/QTE	ITEM NO. DE L'ART	IDENTIFYING NO. D'IDENTIFICATION	NOMENCLATURE	DESCRIPTION	SPECIFICATION	NSCM CAOF
1	1		WEBBING, COTTON, ELASTIC, 5" FREE LENGTH.		SEE NOTE 2	
2	2		WEBBING, COTTON, ELASTIC, 35" FREE LENGTH.			
2	3	CS-289-1	BUCKLE, SUSPENDER, 1 1/2"			
2	4	8490386-1	HOLDER ASSY, STRAP			
3	5	8490387-1	STRAP, BUTTON			
2	6	8490388-1	REINFORCEMENT, BACK-JUNCTION, LEATHER			
1	7	8490389-1	HOLDER, BUTTON STRAP			
AR	8		THREAD, COTTON, NO. 36, 4-CORD, GLAZED FINISH		D-87-001-177 /SF-001	

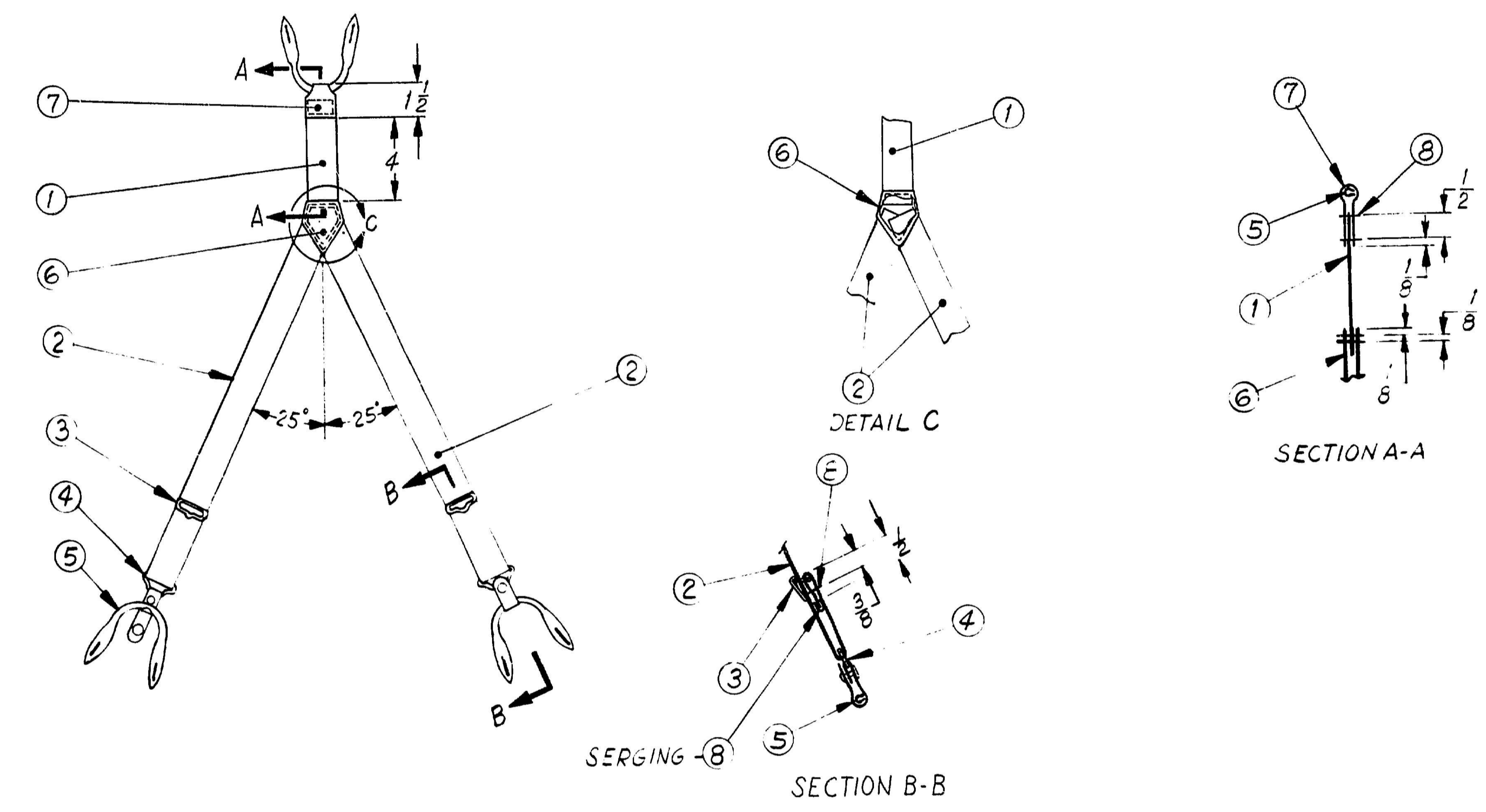

Millimètres
0 20 40 60 80 100 120 140 160 180 200

- NOTES:
- TOLERANCES:
DIMENSIONS 3" OR LESS $\pm \frac{1}{16}$
DIMENSIONS LARGER THAN 3" $\pm \frac{1}{4}$
 - FOR COMPONENTS AND MATERIALS OF COMPONENTS NOT SPECIFIED SEE APPLICABLE SPECIFICATION.



NOTICE
This documentation has been reviewed by the technical authority and does not contain controlled goods. Disclosure notices and handling instructions originally received with the document shall continue to apply.

AVIS
Cette documentation a été révisée par l'autorité technique et ne contient pas de marchandises contrôlées. Les avis de divulgation et les instructions de manutention reçues originalement doivent continuer de s'appliquer.

SEE DATA LIST DL-8490385-1
SPECIFICATION D-87-001-197/SF-001
NSN 8440-21-899-1687
SEALED PATTERN No DCGEM 103-83

**CAUTION - REDUCED SIZE PRINT
NOT FOR MANUFACTURE**

UNLESS OTHERWISE SPECIFIED: SAUF INDICATION CONTRAIRE:		APPLICATION/USAGE	
1. DIMENSIONS ARE IN INCHES DIMENSIONS SONT EN	2. TOLERANCES FRACTIONS \pm DECIMALS \pm DECIMALES \pm	SEE NOTE 1	
3. SURFACE FINISH FINIS DE SURFACES	4. ORIGINAL SCALE ECHELLE ORIGINALE	<input checked="" type="checkbox"/>	$\frac{1}{4}$
DRAWING INTERPRETATION INTERPRETER LE DESSIN PAR		CF D-01-400-001/SG-000 LEVEL/NIVEAU 3	

ZONE	LTR LET	REVISION	DATE	DWN DES	CKD VER	APPVL APP
B		T-DAN 864470027	86-05-15	G.C	sc	RC
A		TDAN 854470035	85-05-22	ALS	sc	PAB
DND - CANADIAN FORCES CANADIENNES - MDN						
DWN/DESS	CRD/VER	QA/AQ	CF APPVL/APP FC			
A.L. STACHIW	G. CURRY		DCGEM 2-4	PAB		
DESIGN AGENT/CONCEPTION	NSCM/CAOF		DRAWING DATE DU DESSIN	AI		
DDDS 4-4	35907		84-12-19			
TITLE/TITRE			DRAWING NO. DU DESSIN			
SUSPENDERS, TROUSERS, LEATHER TAB			8490385			
SHEET			1		OF 1	
FEUILLE			1		DE 1	

QTY/QTE	-NO -/ ITEM NO. DE L'ART	IDENTIFYING NO. D'IDENTIFICATION	NOMENCLATURE	DESCRIPTION	SPECIFICATION	NSCM CAOF
1	1		STRAP, LEATHER		SEE NOTE 1.	
1	2	1-5010	FRONT BUTTON, FASTENER, SUSPENDER			
1	3	5021	SOCKET, FASTENER, SUSPENDER			77681
1	4	5033	STUD, FASTENER, SUSPENDER			
1	5	5043	EYELET, FASTENER, SUSPENDER			
1	6	CS-291-2	HOOK, SUSPENDER			
1	7	CS-291-4	LOOP, STRAP			

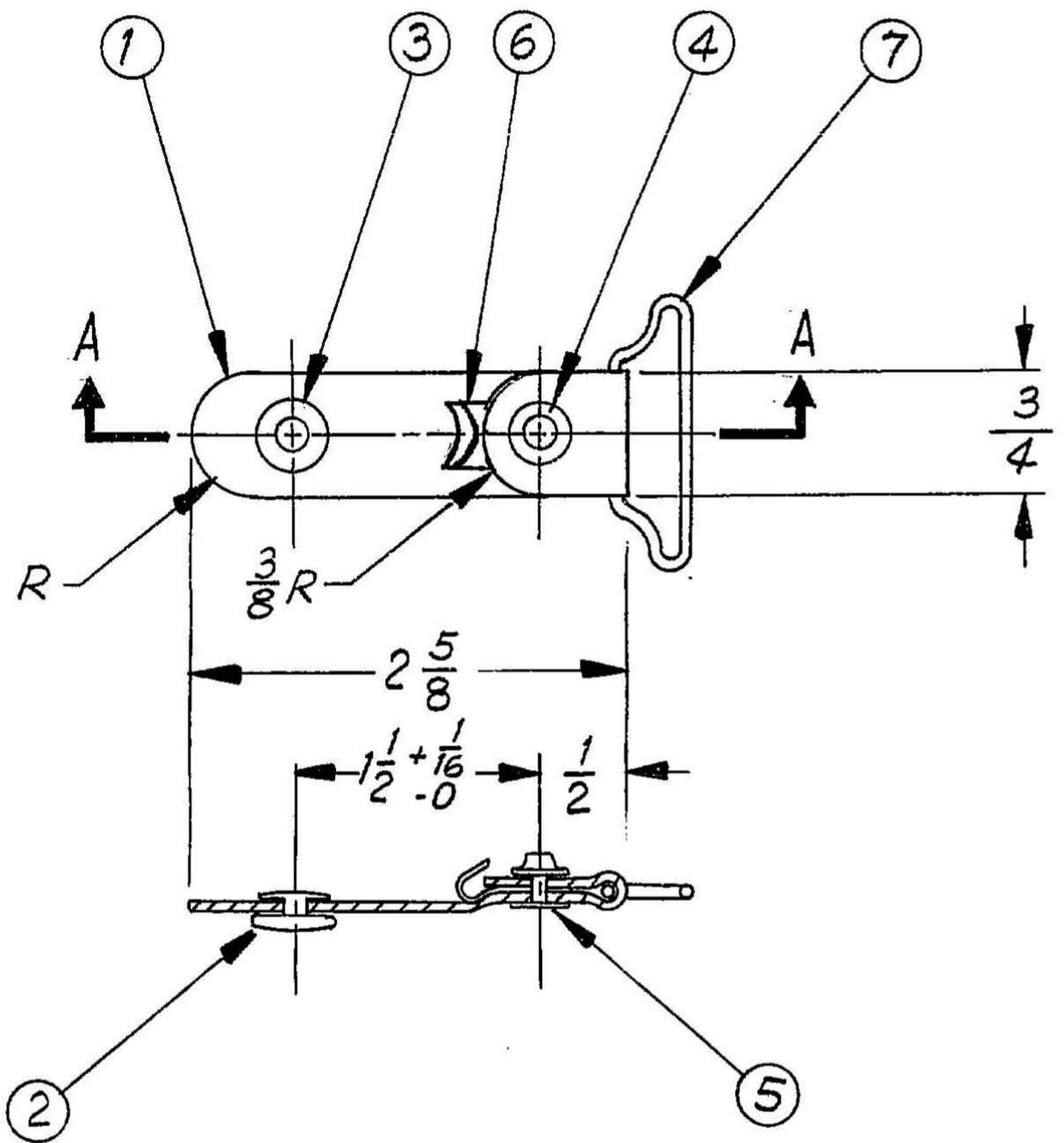

SECTION A-A

NOTICE

This documentation has been reviewed by the technical authority and does not contain controlled goods. Disclosure notices and handling instructions originally received with the document shall continue to apply.

AVIS

Cette documentation a été révisée par l'autorité technique et ne contient pas de marchandises contrôlées. Les avis de divulgation et les instructions de manutention reçues originalement doivent continuer de s'appliquer.



NOTES:

1. FOR COMPONENTS & MATERIALS OF COMPONENTS NOT SPECIFIED SEE APPLICABLE SPECIFICATION.

UNLESS OTHERWISE SPECIFIED: SAUF INDICATION CONTRAIRE	
1. DIMENSIONS ARE IN INCHES DIMENSIONS SONT EN	2. TOLERANCES FRACTIONS ± 1/16 DECIMALS ± - DECIMALES ± -
3. SURFACE FINISH FINIS DE SURFACES	✓ ANGLS ± -
4. ORIGINAL SCALE ÉCHELLE ORIGINALE	1/1 HOLE SIZES DIM DE TROUS ± - HOLE CENTRES CENTRE DE TROUS ±
DRAWING INTERPRETATION INTERPRETER LE DESSIN PAR	CF D-01-400-001/SG-000 LEVEL/NIVEAU 3

APPLICATION/USAGE
8490385

ZONE	A	TRN	TDAN 854470035	DATE	85-05-22	DWN DES	ALS	CKD VER	98	APPVL APP	RAB
DND - CANADIAN FORCES CANADIENNES - MDN											
DWN/DESS	A-L. STACHIW	CKD/VER	G. CURRY 98	QA/AQ	-	CF APPVL/APP FC	DCGEM 2-4 R H6				
DESIGN AGENT/CONCEPTION	DDDS 4-4	NSCM/CAOF	35907	DRAWING DATE DU DESSIN	84-12-19						A2
TITLE/TITRE						DRAWING NO. DU DESSIN					
HOLDER ASSY, STRAP						8490386					
SHEET				1		OF		1		DE	

NO	ITEM NO. DE L'ART	IDENTIFYING NO. D'IDENTIFICATION	NOMENCLATURE	DESCRIPTION	SPECIFICATION	NSCM CAOF
1	1		LEATHER		SEE NOTE 2	
AR	2		THREAD, COTTON		D-87-001-177 /SF-001	

Millimetres
Millimètres

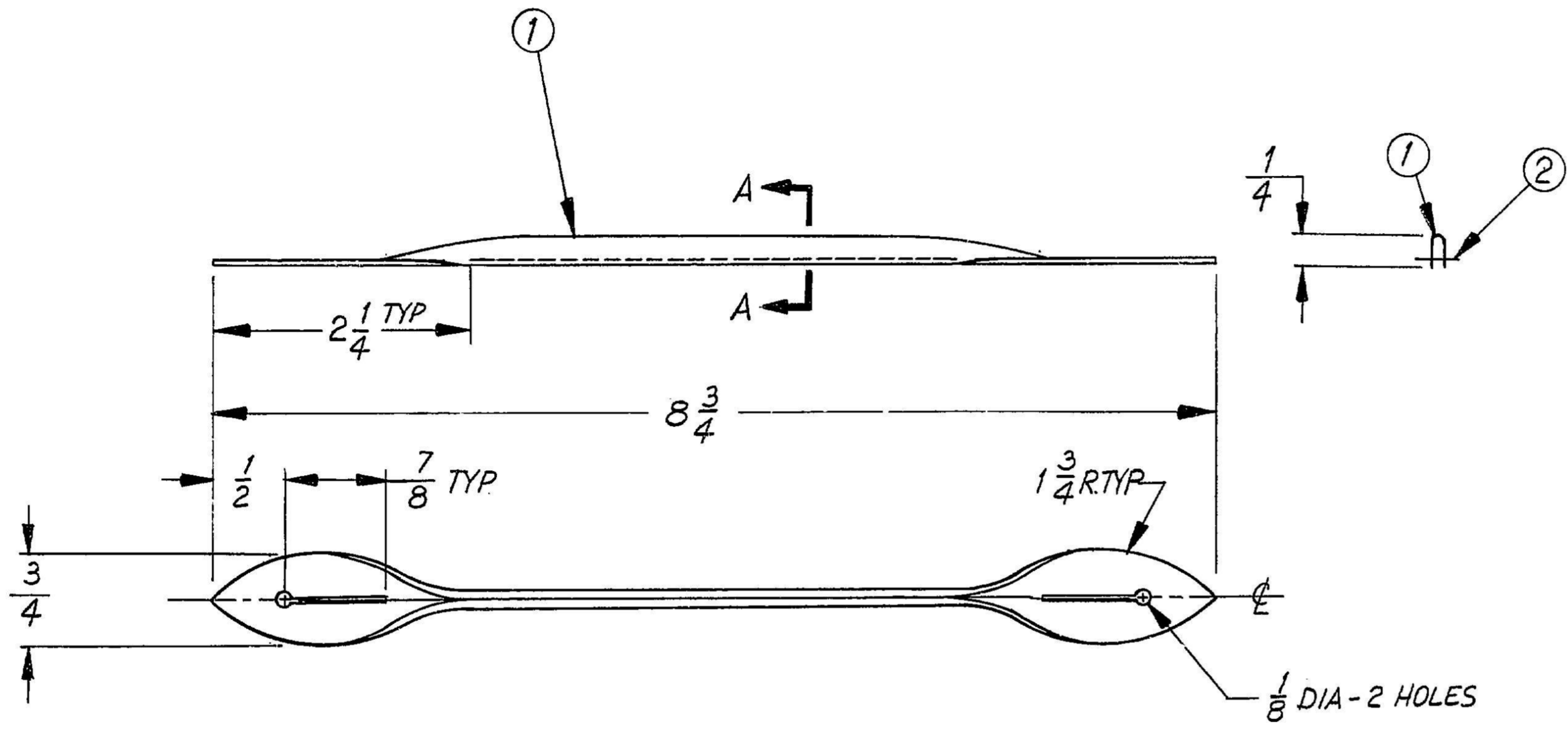

NOTICE

This documentation has been reviewed by the technical authority and does not contain controlled goods. Disclosure notices and handling instructions originally received with the document shall continue to apply.



AVIS

Cette documentation a été révisée par l'autorité technique et ne contient pas de marchandises contrôlées. Les avis de divulgation et les instructions de manutention reçues originalement doivent continuer de s'appliquer.

NOTES:

- TOLERANCE:
DIMENSIONS LESS THAN 1 INCH $\pm \frac{1}{16}$
DIMENSIONS 1 INCH OR LARGER $\pm \frac{1}{8}$
- FOR COMPONENTS AND MATERIALS OF COMPONENTS NOT SPECIFIED SEE APPLICABLE SPECIFICATIONS.

UNLESS OTHERWISE SPECIFIED: SAUF INDICATION CONTRAIRE		APPLICATION/USAGE		ZONE		REVISION		DATE		DWN DES		CKD VER		APPVL APP	
1. DIMENSIONS ARE IN INCHES DIMENSIONS SONT EN		2. TOLERANCES FRACTIONS \pm DECIMALS \pm		8490385		A		T DAN 854470035		85-05-22		ALS		SE. RAB	
3. SURFACE FINISH FINIS DE SURFACES		4. ORIGINAL SCALE ECHELLE ORIGINALE													
-J		1													
DND - CANADIAN FORCES CANADIENNES - MDN		DWN/DESS		CKD/VER		QA/AQ		CF APPVL/APP FC		DRAWING DATE DU DESSIN		DRAWING NO. DU DESSIN		SHEET OF	
A.L. STACHIW		G. CURRY RB.		-		-		DCGEM 2-4 RAB		84-12-19		8490387		1 OF 1	
DESIGN AGENT / CONCEPTION		NSCM / CAOF		TITLE / TITRE		STRAP, BUTTON									
DDDS 4-4		35907													
DRAWING INTERPRETATION INTERPRETER LE DESSIN PAR		CF D-OI-400-001/SG-000 LEVEL/NIVEAU													

NO	ITEM NO. DE L'ART	IDENTIFYING NO. D'IDENTIFICATION	NOMENCLATURE	DESCRIPTION	SPECIFICATION	NSCM CAOF
-1	1		LEATHER		SEE NOTE 2	

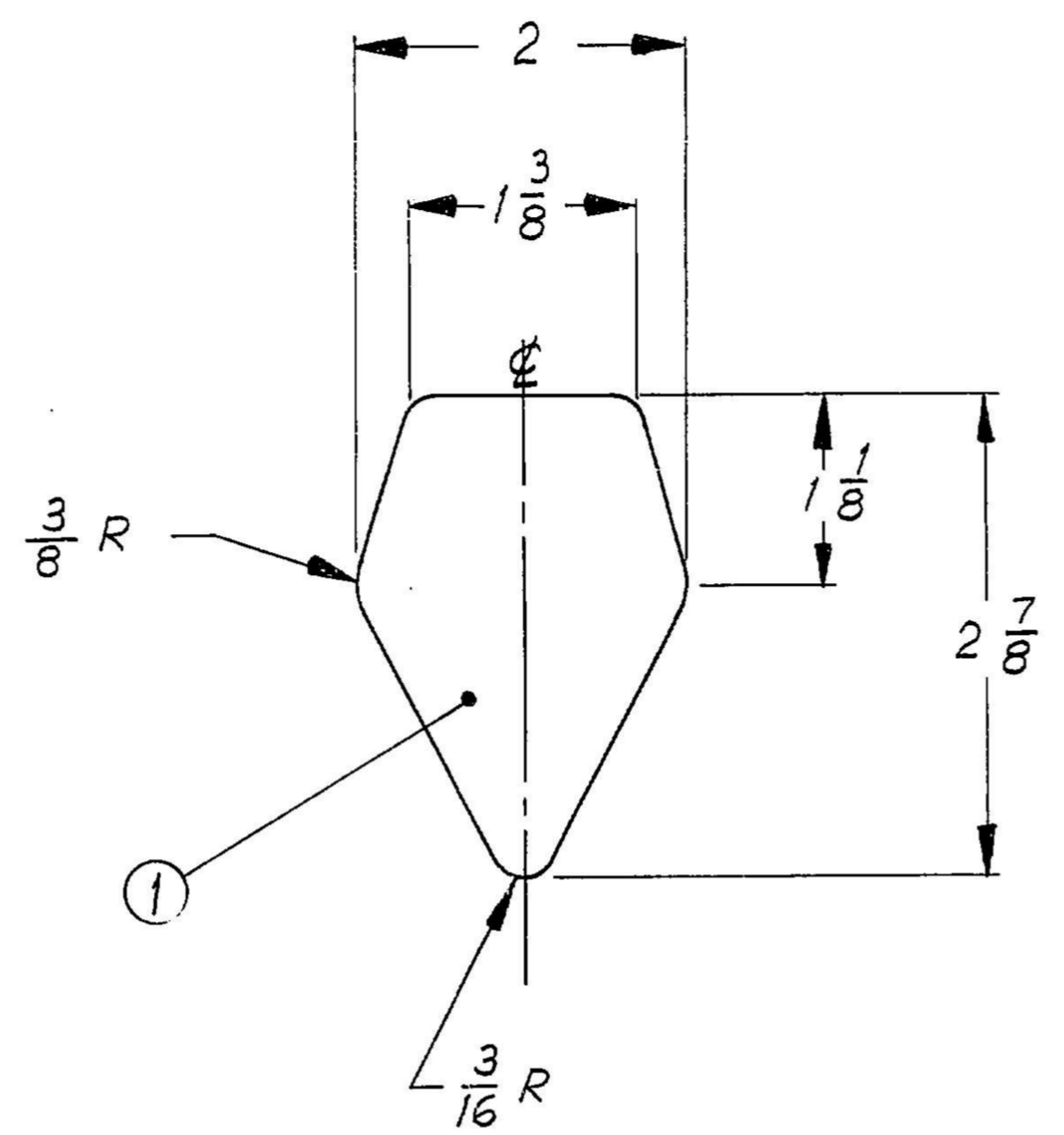

Millimètres
0 20 40 60 80 100 120 140 160 180 200

NOTICE

This documentation has been reviewed by the technical authority and does not contain controlled goods. Disclosure notices and handling instructions originally received with the document shall continue to apply.

AVIS

Cette documentation a été révisée par l'autorité technique et ne contient pas de marchandises contrôlées. Les avis de divulgation et les instructions de manutention reçues originalement doivent continuer de s'appliquer.



NOTES:

1. FOR COMPONENTS & MATERIALS OF COMPONENTS NOT SPECIFIED SEE APPLICABLE SPECIFICATION.

UNLESS OTHERWISE SPECIFIED: SAUF INDICATION CONTRAIRE		APPLICATION/USAGE 8490385		ZONE	LTR LET	REVISION	DATE	DWN DES	CKD VER	APPVL APP	
1. DIMENSIONS ARE IN INCHES DIMENSIONS SONT EN		2. TOLERANCES FRACTIONS ± 1/16 DECIMALS ± - DECIMALES ± -		DND - CANADIAN FORCES CANADIENNES - MDN							
3. SURFACE FINISH FINIS DE SURFACES		√		DWN/DESS A.L. STACHIW		CKD/VER G. CURRY		QA/AQ -		CF APPVL/APP FC DCGEM 2-4 RAB	
4. ORIGINAL SCALE ÉCHELLE ORIGINALE		1/1		DESIGN AGENT/CONCEPTION DDDS 4-4		NSCM/CAOF 35907		DRAWING DATE DU DESSIN 84-12-19		A2	
DRAWING INTERPRETATION INTERPRETER LE DESSIN PAR		CF D-01-400-001/SG-000 LEVEL/NIVEAU 3		TITLE/TITRE REINFORCEMENT, BACK JUNCTION, LEATHER				DRAWING NO. DU DESSIN 8490388			
				SHEET FEUILLE 1				OF DE 1			

-NO	ITEM NO. DE L'ART	IDENTIFYING NO. D'IDENTIFICATION	NOMENCLATURE	DESCRIPTION	SPECIFICATION	NSCM CAOF
1	1		LEATHER		SEE NOTE 1	

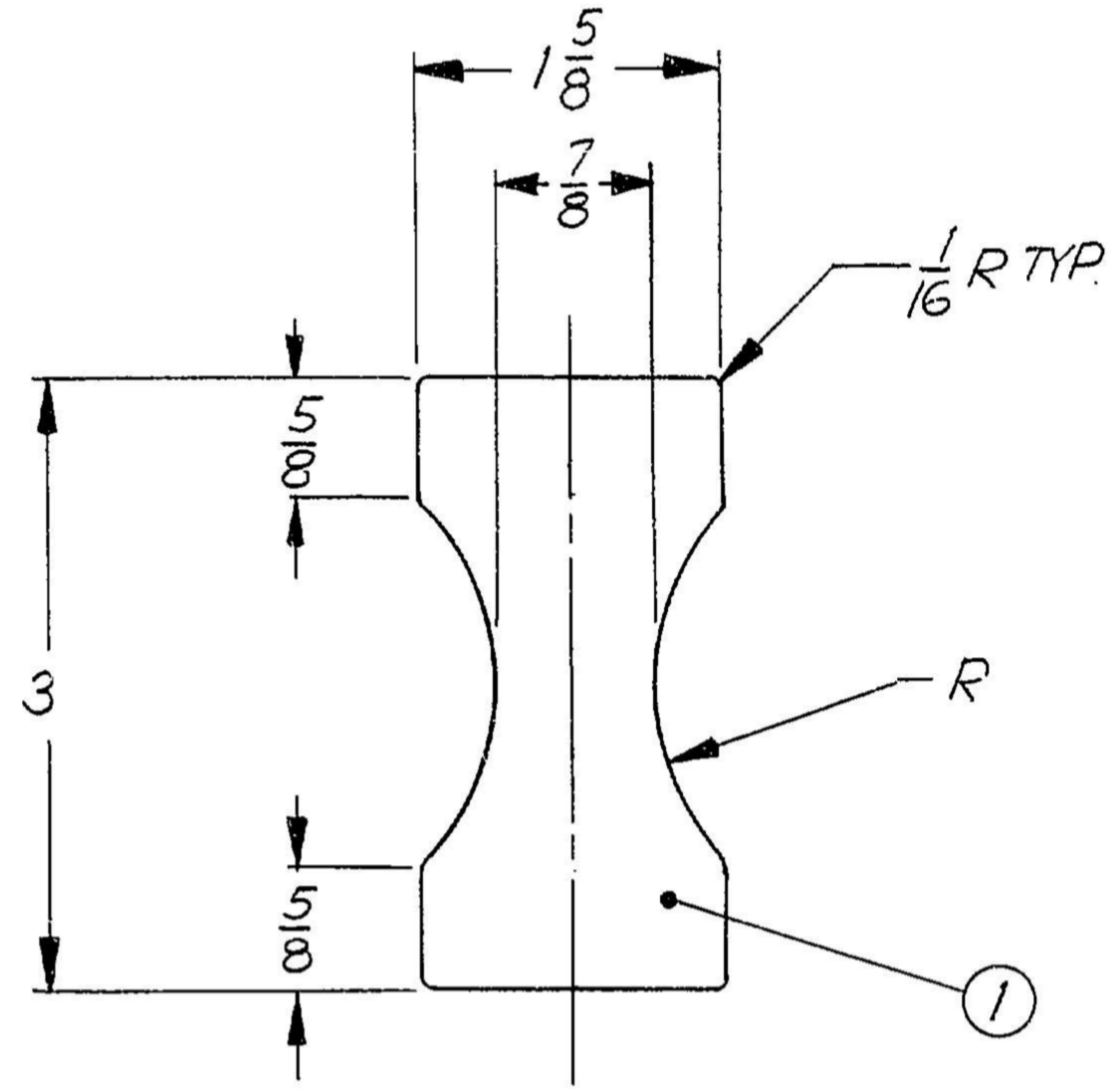

NOTICE

This documentation has been reviewed by the technical authority and does not contain controlled goods. Disclosure notices and handling instructions originally received with the document shall continue to apply.

AVIS

Cette documentation a été révisée par l'autorité technique et ne contient pas de marchandises contrôlées. Les avis de divulgation et les instructions de manutention reçues originalement doivent continuer de s'appliquer.



NOTES:

1. FOR COMPONENTS & MATERIALS OF COMPONENTS NOT SPECIFIED SEE APPLICABLE SPECIFICATION.

UNLESS OTHERWISE SPECIFIED:
 SAUF INDICATION CONTRAIRE

1. DIMENSIONS ARE IN INCHES DIMENSIONS SONT EN	2. TOLERANCES FRACTIONS ± 1/16 DECIMALS ± - DECIMALES ± -
3. SURFACE FINISH FINIS DE SURFACES	√ ANGLES ± - HOLE SIZES DIM DE TROUS ± - HOLE CENTRES CENTRE DE TROUS ± -
4. ORIGINAL SCALE ECHELLE ORIGINALE	1/1

DRAWING INTERPRETATION
 INTERPRETER LE DESSIN PAR

CF D-01-400-001/SG-000
 LEVEL/NIVEAU 3

APPLICATION/USAGE
 8490385

ZONE	LTR LET	REVISION	DATE	DWN DES	CKD VER	APPVL APP
A		T DAN 854470035	85-05-22	ALS	J.E.	RAB
DND - CANADIAN FORCES CANADIENNES - MDN						
DWN/DESS	CKD/VER	QA/AQ	CF APPVL/APP FC			
A.L. STACHIW	G. CURRY J.E.	-	DCGEN 2-4 RAB			
DESIGN AGENT / CONCEPTION	NSCM / CAOF	DRAWING DATE DU DESSIN		AE		
DDDS 4-4	35907	84-12-19				
TITLE / TITRE			DRAWING NO. DU DESSIN			
HOLDER, BUTTON STRAP			8490389			
SHEET / FEUILLE		OF / DE				
1		1				

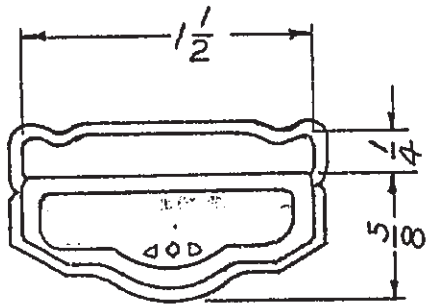

CS-289-1

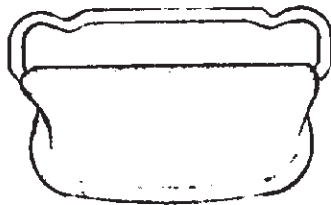
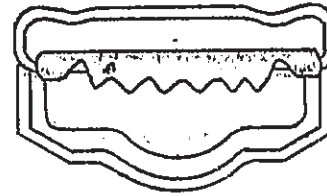

CS-289-2

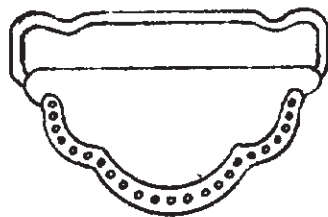

CS-289-3

MATERIAL: *STEEL OR BRASS*

FINISH: *AS REQUIRED*

TOLERANCE:

UNLESS OTHERWISE SPECIFIED, FRACTIONS $\pm \frac{1}{16}$ DECIMALS \pm ANGLES \pm

DIMENSIONS IN INCHES

REVISION

DRAWN BY: *J. L. J.*
23 MAY 1958
APPROVED BY: *[Signature]*

DIRECTORATE OF INTER-SERVICE DEVELOPMENT
BUCKLE, SUSPENDER $\frac{1}{2}$ "

CS-289

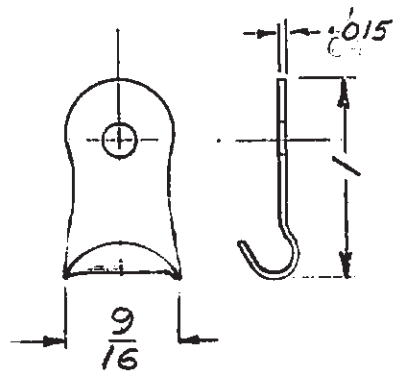

CS-291-1

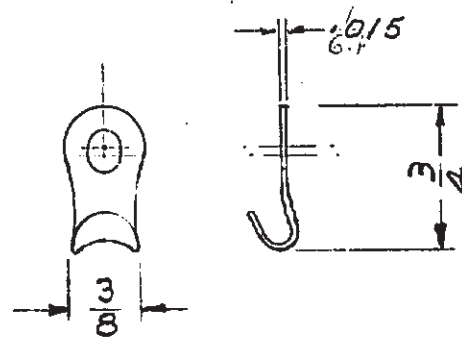

CS-291-2

MATERIAL: *STEEL OR BRASS*

FINISH: *AS REQUIRED*

TOLERANCE:

UNLESS OTHERWISE SPECIFIED, FRACTIONS $\pm \frac{1}{16}$

DECIMALS $\pm .002$

ANGLES \pm

DIMENSIONS IN INCHES

REVISION

DRAWN BY: *J. L. J.*
23 MAY 1958

APPROVED BY:

[Signature]

DIRECTORATE OF INTER-SERVICE DEVELOPMENT

HOOK SUSPENDER

CS-291

H.

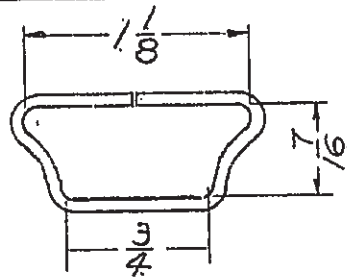

.081 DIA.

CS-292-1

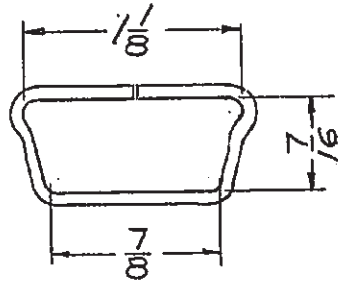

.081 DIA.

CS-292-2

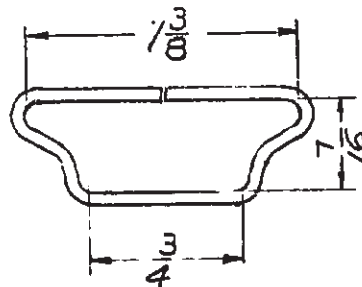

.081 DIA.

CS-292-3

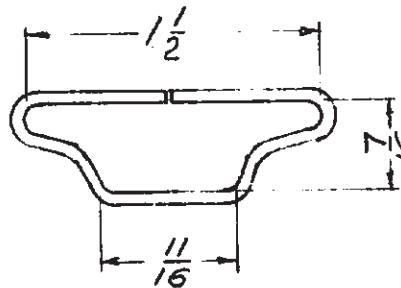

.081 DIA.

CS-292-4

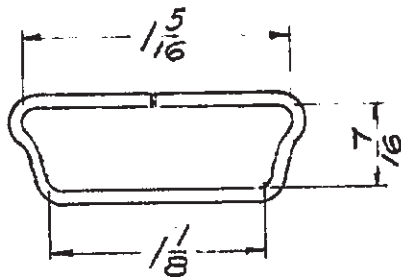

.081 DIA.

CS-292-5

MATERIAL: STEEL OR BRASS

FINISH: AS REQUIRED

TOLERANCE:

UNLESS OTHERWISE SPECIFIED, FRACTIONS $\pm \frac{1}{32}$

DECIMALS $\pm .010$

ANGLES \pm

DIMENSIONS IN INCHES



REVISION

DRAWN BY: J. L. J.
4 JUNE 1958

APPROVED BY: [Signature]

DIRECTORATE OF INTER-SERVICE DEVELOPMENT
LOOP STRAP

CS-292