

2

1

NOTES :

- BASE RADII MATCHES TUBING RADII USED FOR FABRICATION
- THIS DRAWING SHOWS SPECS ONLY

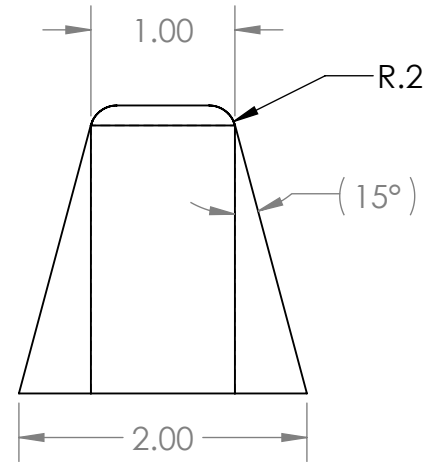
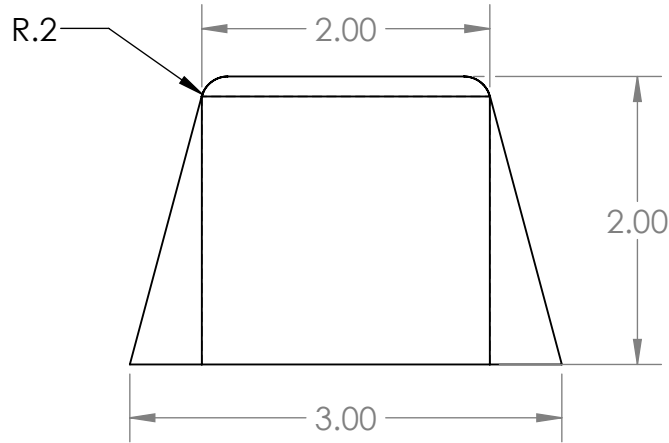
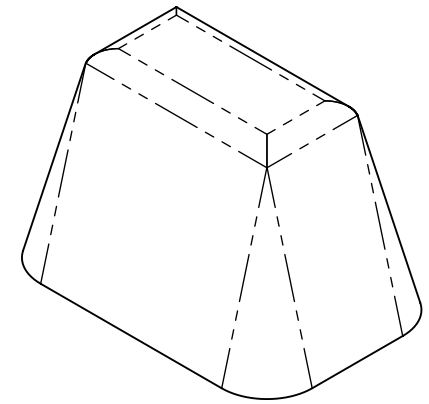
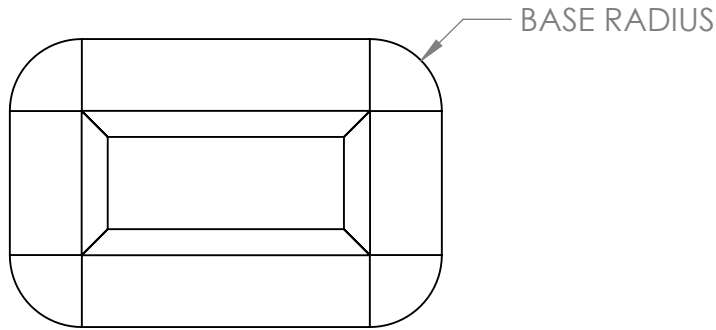

B

B

A

A

UNLESS OTHERWISE SPECIFIED:		NAME	SIGNATURE	DATE	PROJECT		
DIMENSIONS ARE IN INCHES TOLERANCES: ANGULAR: MACH ± .1° FRACTIONAL ± 1/32 TWO PLACE DECIMAL ± .010" THREE PLACE DECIMAL ± .005" BREAK ALL SHARP EDGES .01" - .02"	DRAWN			mm/dd/yyyy	HIGH SECURITY FENCE TITLE <h2>STEEL SKID - POINTED TOP</h2>		
	CHECKED						
	ENG APPR.						
	MFG APPR.						
INTERPRET GEOMETRIC TOLERANCING PER:	Q.A.				SIZE	DWG. NO.	REV
MATERIAL			PROPRIETARY AND CONFIDENTIAL THE INFORMATION CONTAINED IN THIS DRAWING IS THE SOLE PROPERTY OF THE RCMP . ANY REPRODUCTION IN PART OR AS A WHOLE WITHOUT THE WRITTEN PERMISSION OF THE RCMP IS PROHIBITED.		A		1
FINISH							
DO NOT SCALE DRAWING					SCALE: 1:1	WEIGHT: 0.26 lb	SHEET 1 OF 1

2

1