

- BRISER TOUTES ARETES VIVES .005-.015
- TOLERANCES DECIMALES +/- .005 +/- .0010
- MATERIEL ALU-7075
- ANODISATION DURE MIL-A-8625 TYPE III CLASSE 2 NOIR MAT EPAISSEUR .002
- TOUTES TOLERANCES S APPLIQUE APRES ANODISATION

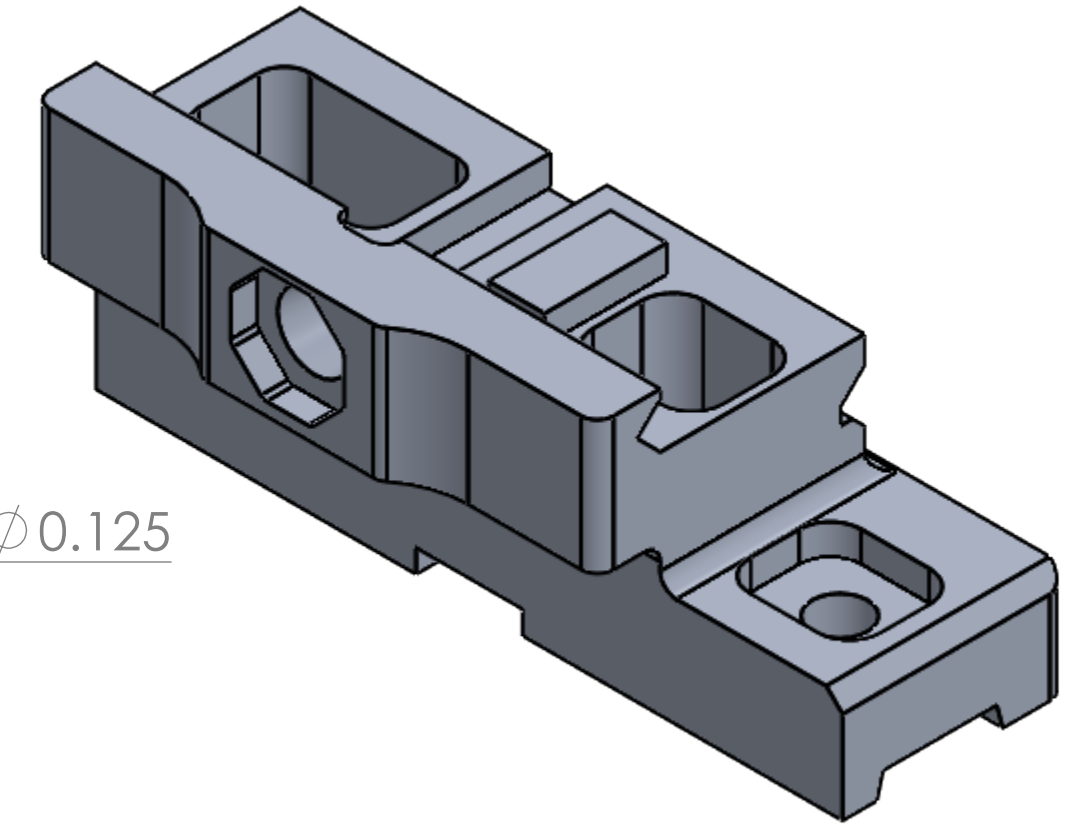
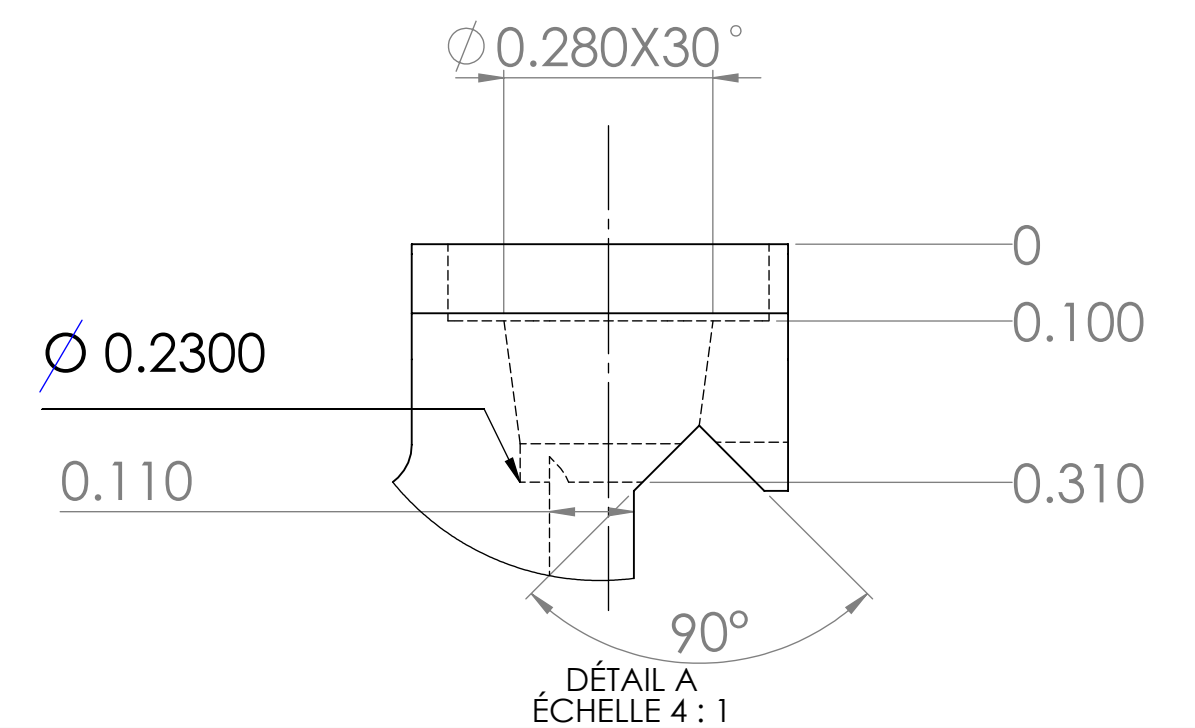
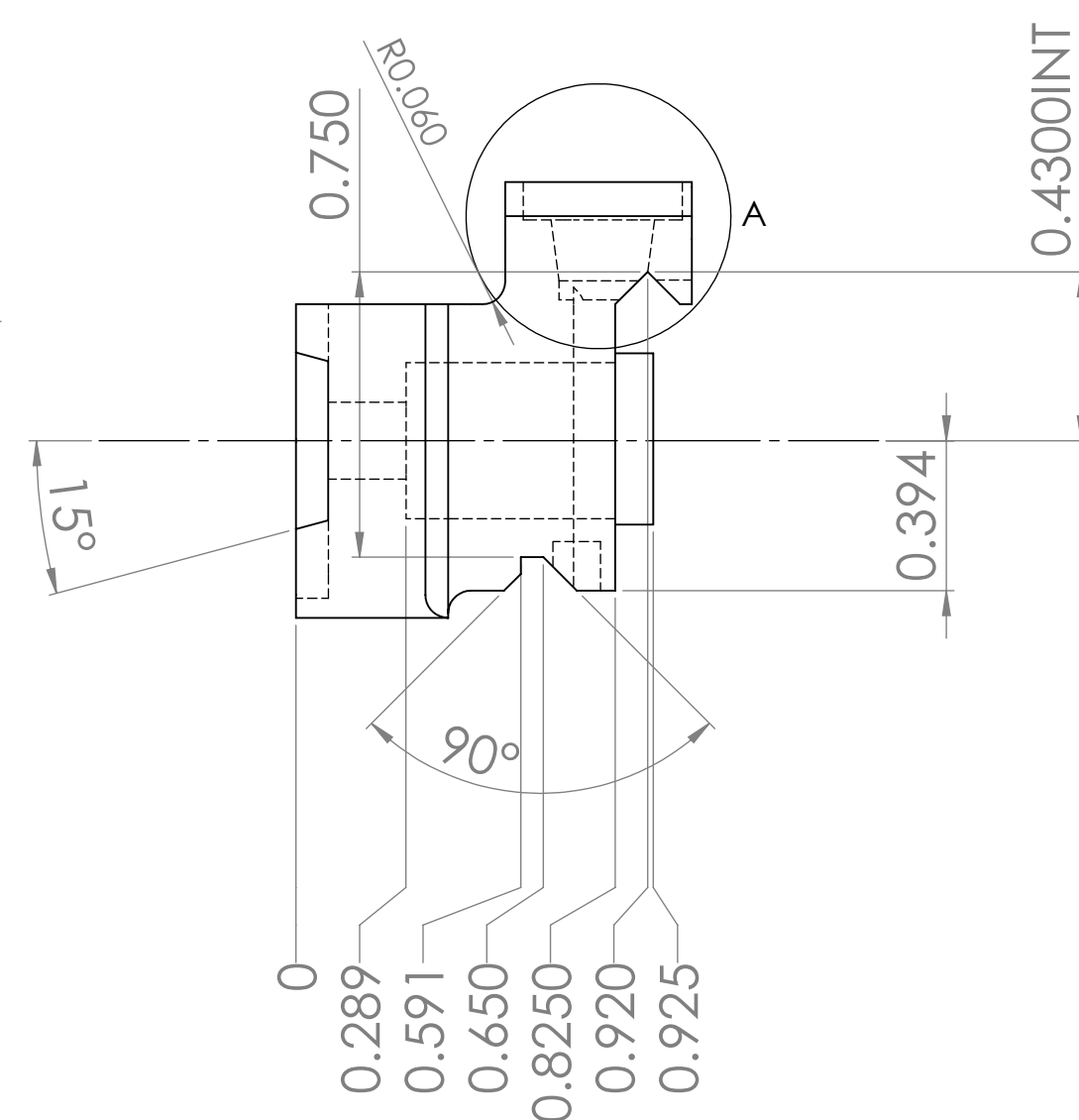
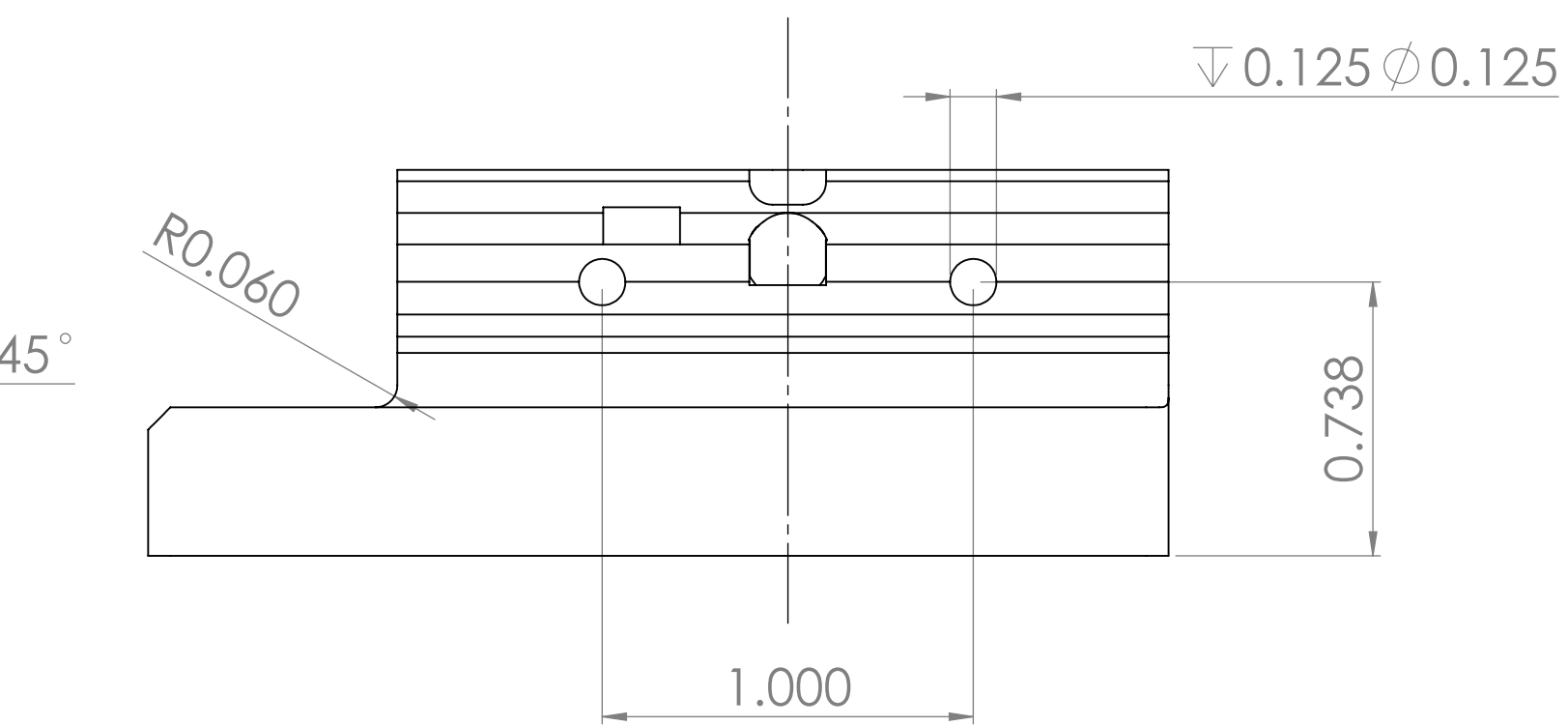
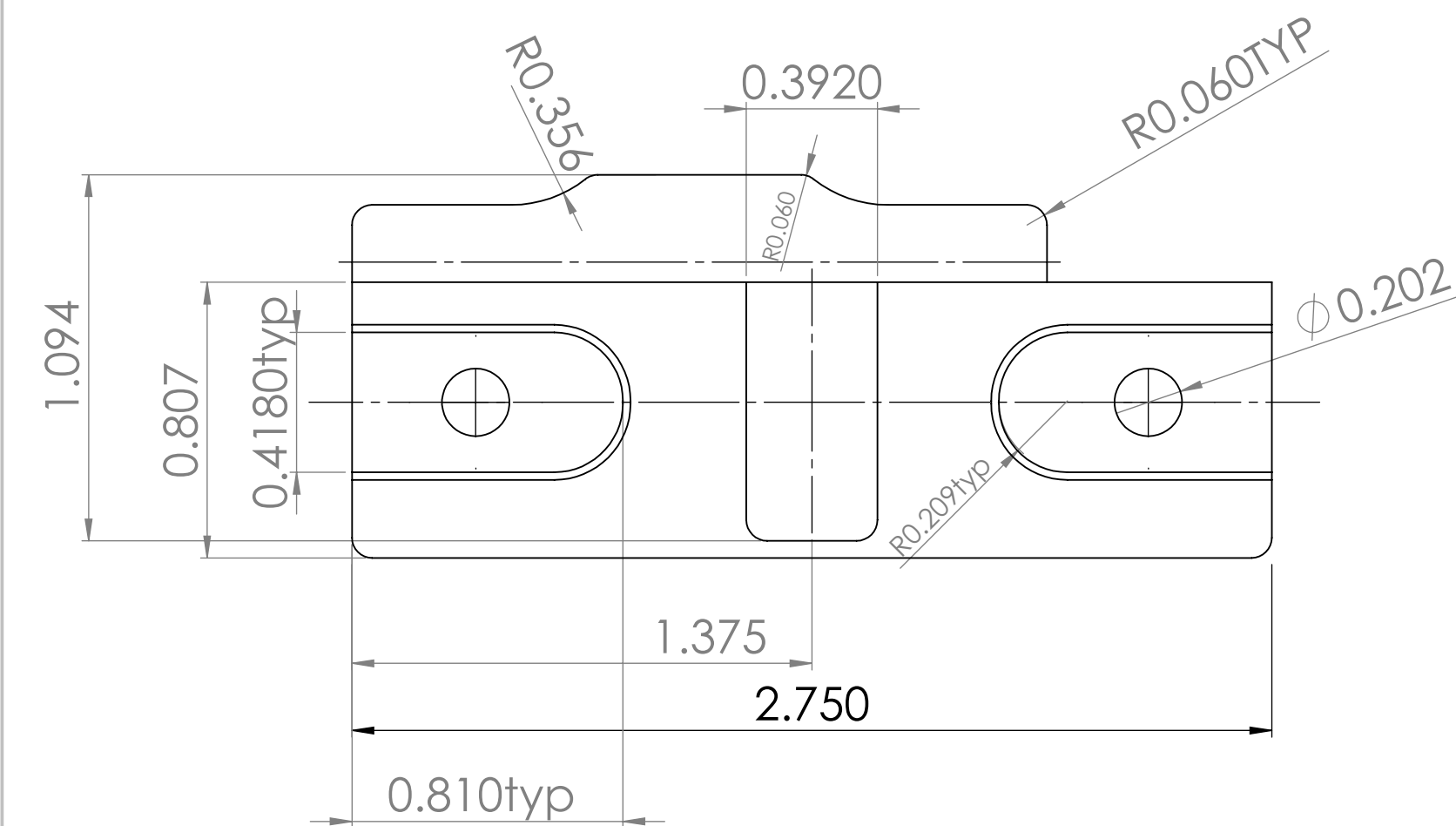
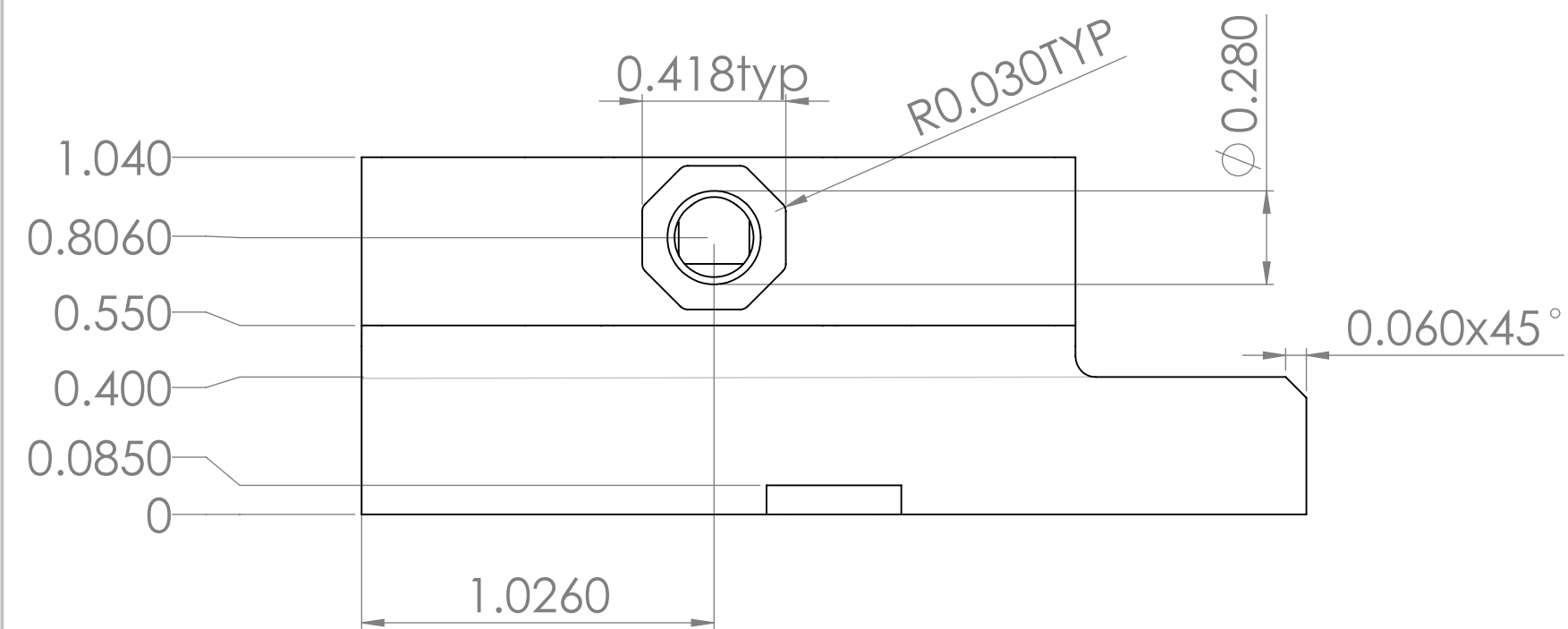
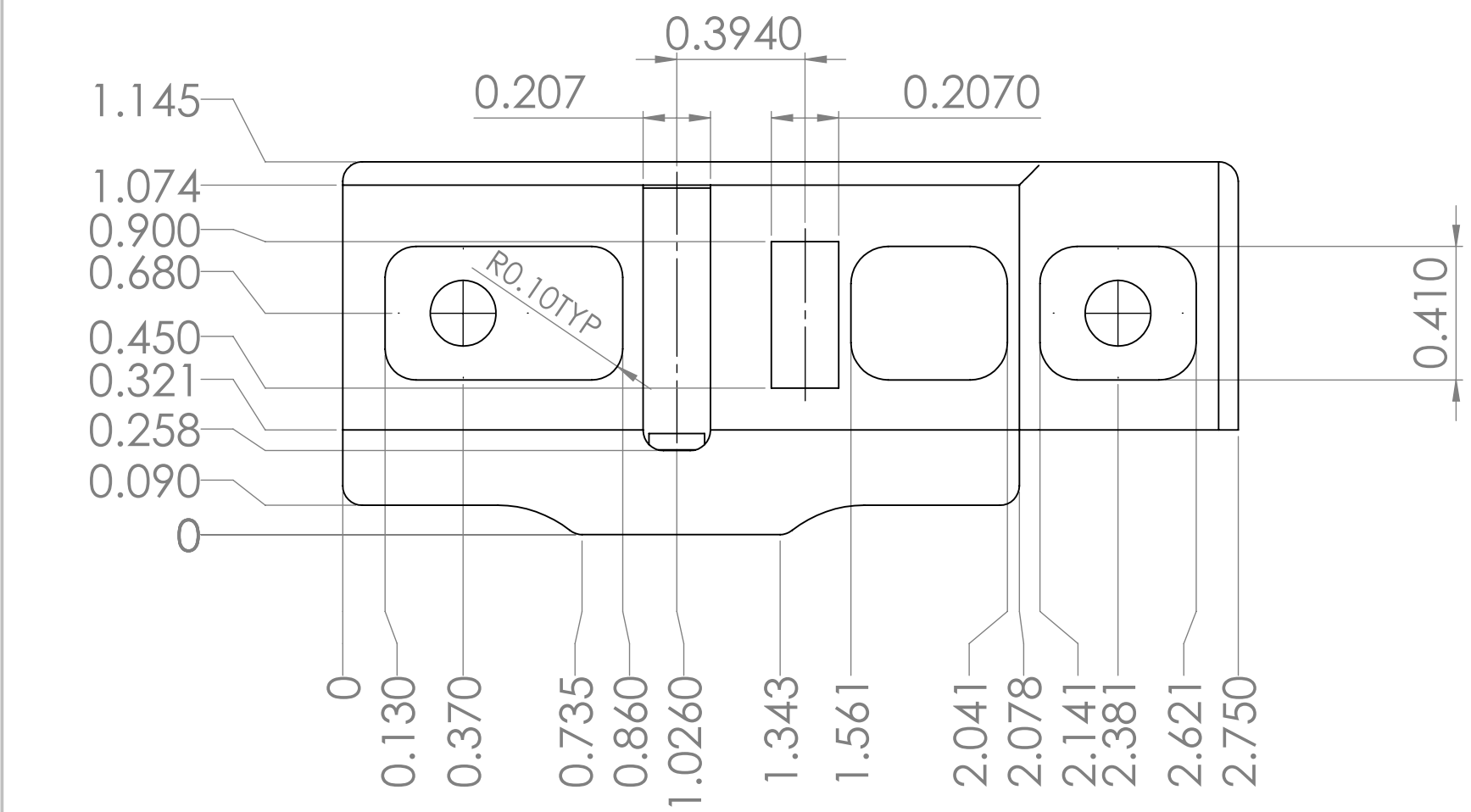

SAUF AVIS CONTRAIRE: LES DIMENSIONS SONT EN MILLIMÈTRES			FINI: PROPRE	ÉBAVURER LES TROUS ET ARRONDIR LES BORDS COUPANTS		NE PAS METTRE LE DESSIN À L'ÉCHELLE	REVISION	
FNI DE SURFACE: TOLERANCES:			GRC-RCMP C8 ADAPTATEUR REV 2 2013-10				TITRE:	
LIGNÉAIRE: ANGULAIRE:							DESSIN NO. 77004000	
DESINÉ PAR	NOM	SIGNATURE	DATE	MATERIAU: 7075-T6		ÉCHELLE: 2:1		
LIBRECTION:	LADOUCEUR		2013-10-10	WEIGHT: 0.138		FEUILLE 1 OF 1		
APPROBATION:								
REVISION:								