

--BRAKE ALL SHARP EDGES .005-.015
 -TOLERANCE DECIMAL +/- .005 +/- .0010
 -HARD COAT ANODIZE MIL-A-8625 TYPE III
 CLASS 2 , MATT BLACK .002 SURFACE
 -ALL TOLERANCE APPLY AFTER ANODIZE

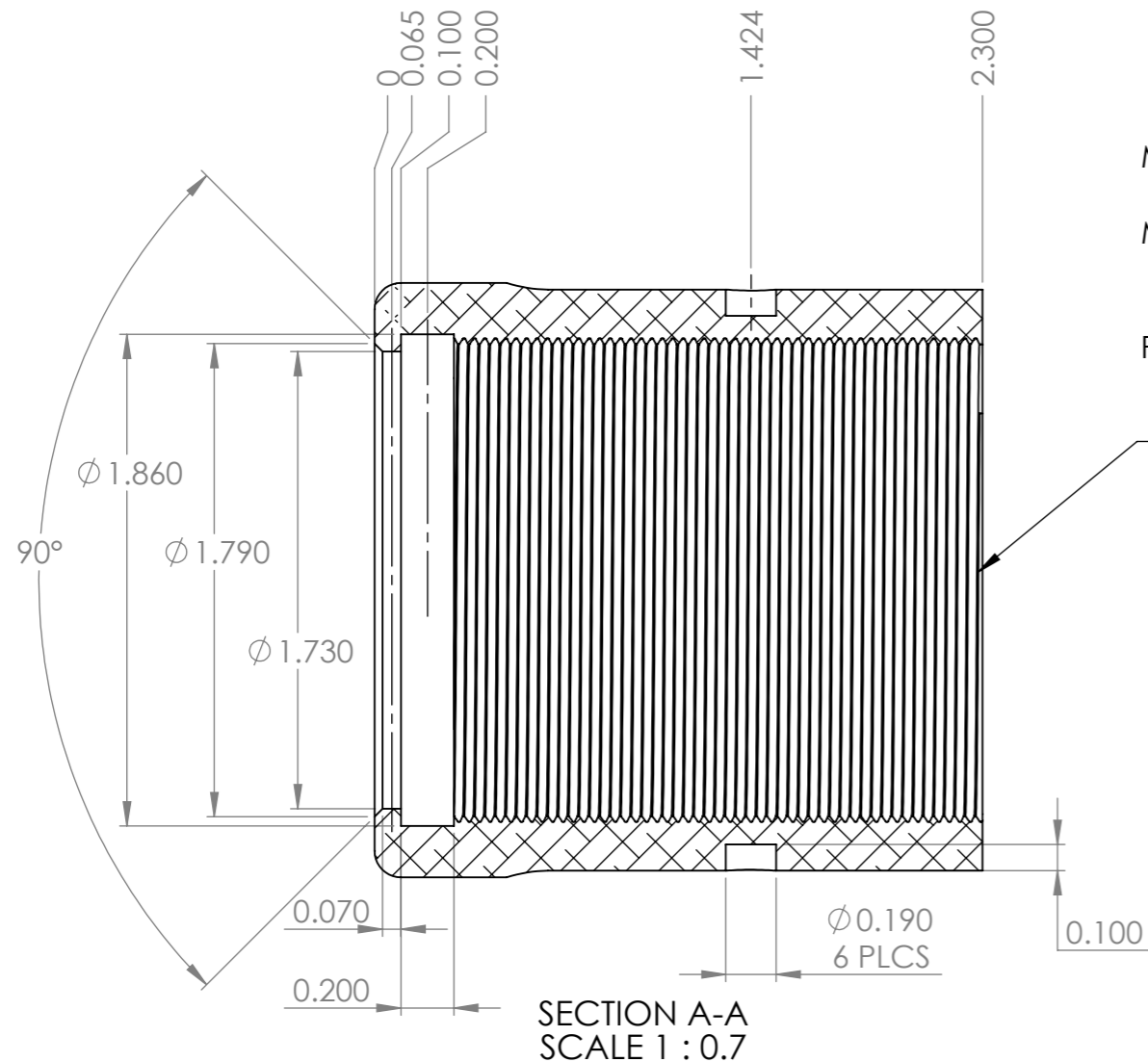
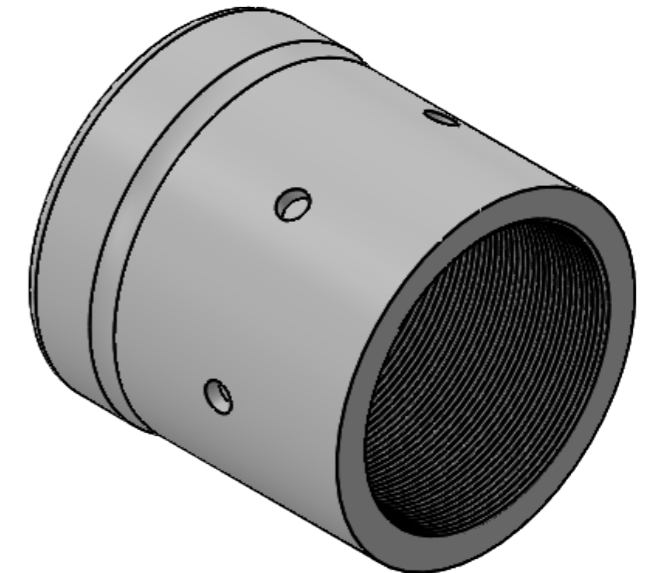

M46.5 X1 - 6H (TROUGH FIRST BRAKE)
 MAJOR DIAMETER MIN 46.526
 MINOR DIAMETER MIN 45.443
 MAX 45.679
 PITCH DIAMETER MIN 45.876
 MAX 46.051

SECTION A-A
 SCALE 1 : 0.7

UNLESS OTHERWISE SPECIFIED: DIMENSIONS ARE IN MILLIMETERS SURFACE FINISH: TOLERANCES: LINEAR: ANGULAR:		FINISH: CLEAN		DEBURR AND BREAK SHARP EDGES		DO NOT SCALE DRAWING		REVISION	
DRAWN		NAME		SIGNATURE		DATE		TITLE: RCMP-GRC	
CHK'D								MUZZLE PROTECTOR	
APPV'D								40MM	
MFG								DWG NO. 77004534	
Q.A						MATERIAL: 7075-T6		A3	
						WEIGHT:		SCALE:1:1	
								SHEET 1 OF 1	