

-BRISER TOUTES ARETES VIVES .005-.015  
 -TOLERANCES DECIMALES +-.005+-.0010  
 -MATERIEL TITANIUM T2 GRADE 5

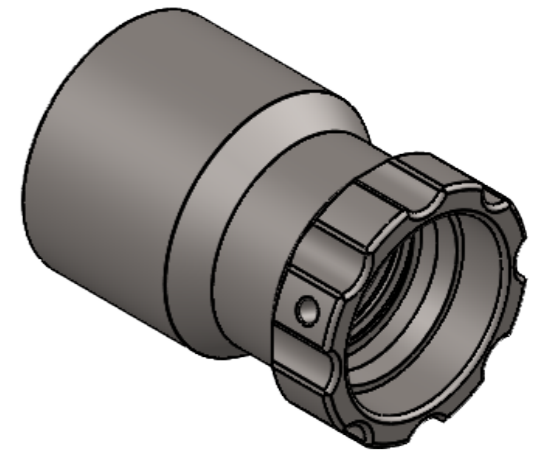

8-32 UNC DE BORD EN BORD DU PREMIER FREIN

1-10 ACME 2G- NON STANDARD- (1.02 PROFOND)  
 -MAX 0.980-1.00  
 -PAS 0.920-0.935  
 -MIN 0.885-0.895

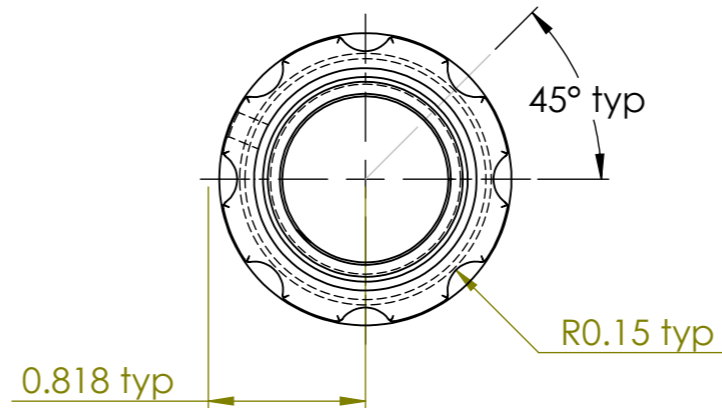
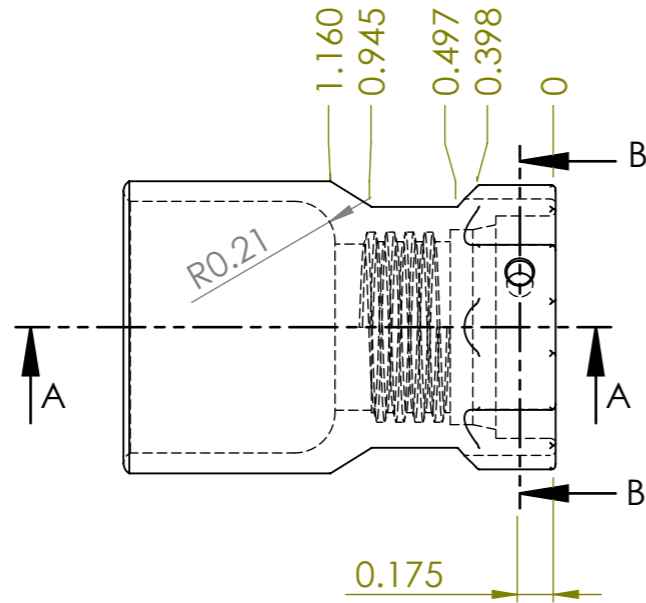
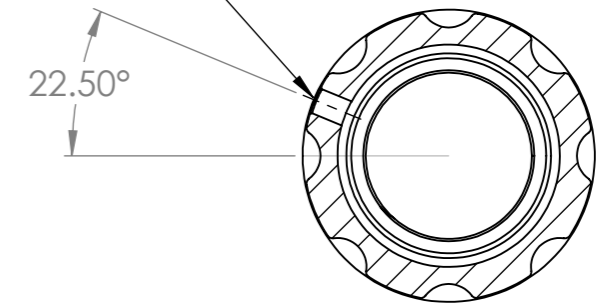

SECTION B-B

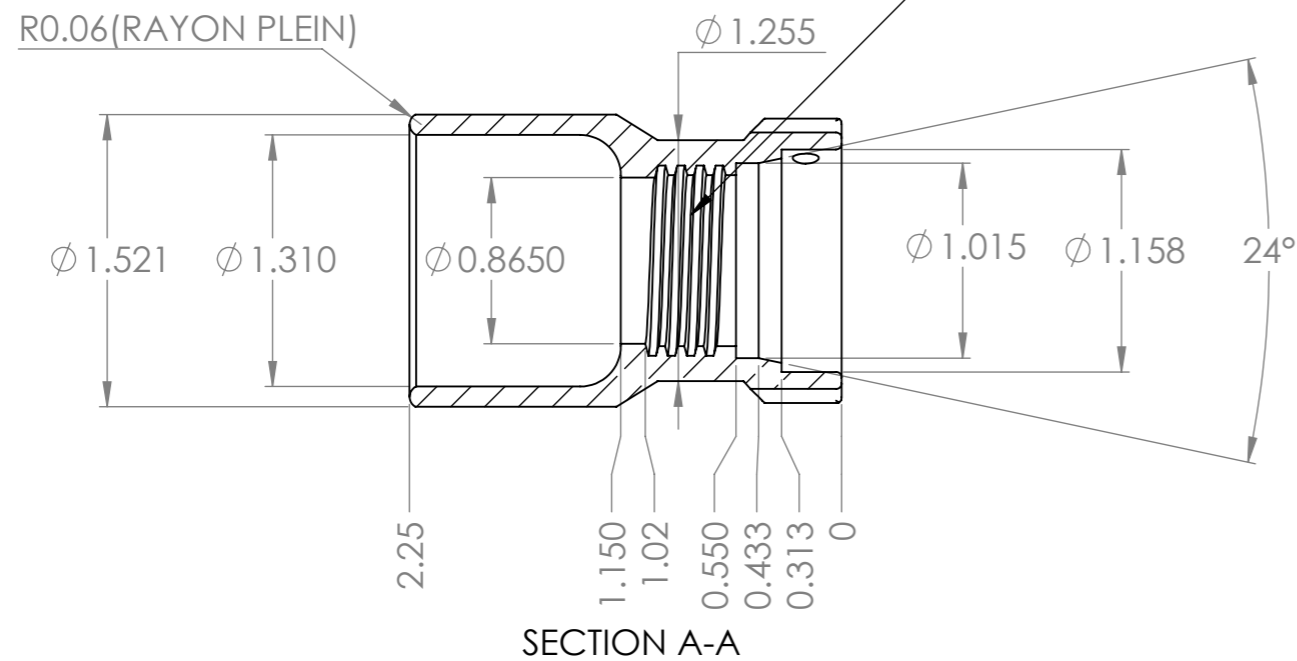

SECTION A-A

SAUF AVIS CONTRAIRE: LES DIMENSIONS SONT EN MILLIMÈTRES. FINI DE SURFACE: TOLÉRANCE: LINÉAIRE: ANGULAIRE:		FINI: <b>PROPRE</b>	ÉBAVURER LES TROUS ET ARRONDIR LES BORDS COUPANTS		NE PAS METTRE LE DESSIN À L'ÉCHELLE	RÉVISION
					<b>GRC-RCMP</b>	
					TITRE: <b>90T BAGUE DE FREIN DE BOUCHE 8-32 verrou</b>	
					DESSIN NO. <b>77004521</b>	
					ÉCHELLE:1:1	
					FEUILLE 1 OF 1	

DESSIN	NOM	SIGNATURE	DATE		
VÉRIFICATION					
APPROBATION					
FABRICANT					
AQ				MATÉRIAU:	
				POIDS:	

A3